



**THE DATASHEET OF
LPAM-20-01.5-S-08-1-K-TR**



DO NOT SCALE FROM THIS PRINT

PATENT PENDING

LPAM-XX-XX.X-X-XX-X-K-XR

TAPE & REEL (SEE NOTES 7 & 9)
 -TR: TAPE & REEL
 -FR: FULL REEL QTY TAPE & REEL

No. OF POSITIONS
 -10, -20, -30, -40, ** -50
 (PER ROW)

LEAD STYLE
 -01.0: 1.0mm
 -01.5: 1.5mm

PLATING SPECIFICATION
 -L: 10µ" GOLD IN CONTACT AREA, MATTE TIN ON TAIL
 -S: 30µ" GOLD IN CONTACT AREA, MATTE TIN ON TAIL

OPTIONS
 -K: POLYIMIDE PAD (SEE SHT 3, FIG. 3)

SOLDER COMPOSITION & STYLE
 -1: 63.0% TIN / 37.0% LEAD CRIMP TAIL
 -2: 95.5% TIN / 3.8% SILVER / .7% COPPER CRIMP TAIL

ROW
 -04: 4 ROWS
 -06: 6 ROWS
 -08: 8 ROWS
 *-10: 10 ROWS

(* = NOT TOOLED)
 (** = NOT TOOLED FOR 04, 06 & 10 ROWS)

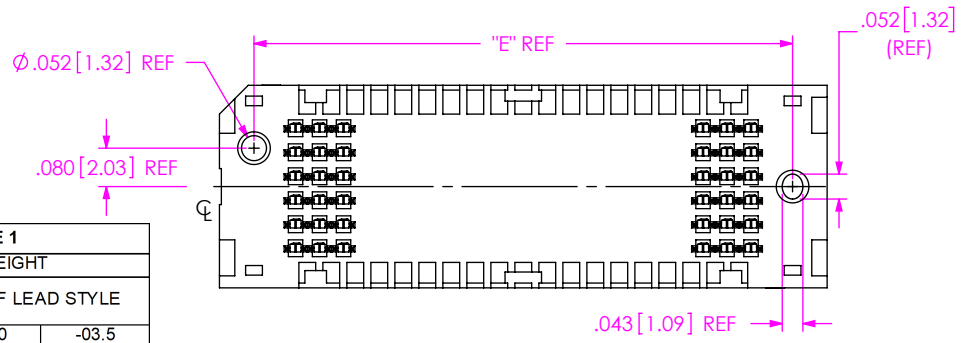
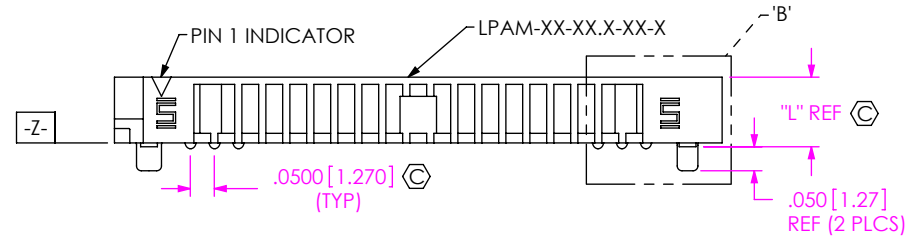
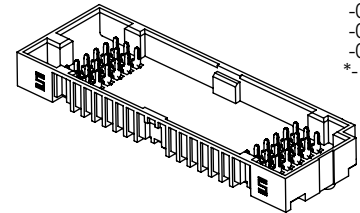
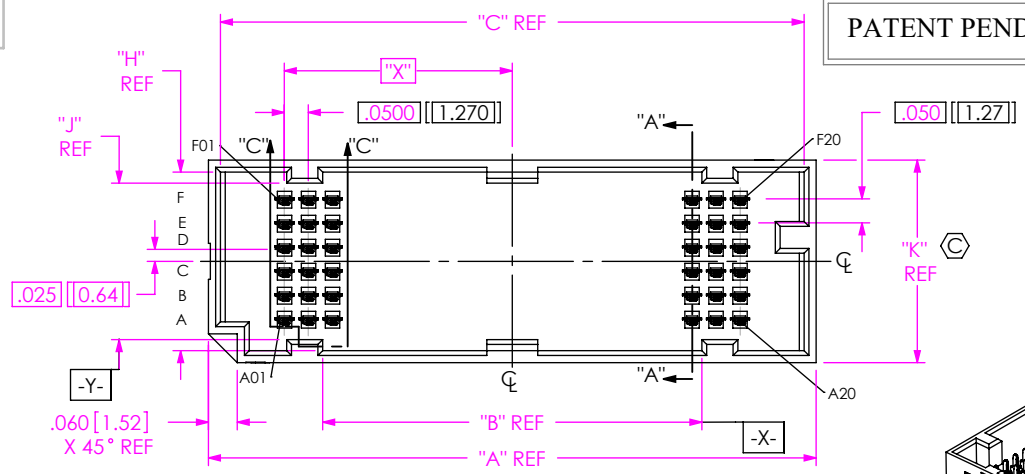

TABLE 5

LEAD STYLE	"L"	"M"	"V"
-01.0	0.145 [3.68]	0.043 [1.09]	0.007 [0.18]
-01.5	0.165 [4.19]	0.063 [1.60]	0.017 [0.43]

TABLE 4

No. OF ROWS	"H"	"J"	"K"
-04	0.272 [6.91]	0.226 [5.74]	0.322 [8.18]
-06	0.372 [9.45]	0.326 [8.28]	0.422 [10.72]
-08	0.472 [11.99]	0.426 [10.82]	0.522 [13.26]
-10	0.572 [14.53]	0.526 [13.36]	0.622 [15.80]

TABLE 3

No. OF POS. PER ROW	"A"	"B"	"C"	"E"	"X"
-10	0.766 [19.46]	0.290 [7.37]	0.716 [18.19]	0.622 [15.80]	0.2222 [5.644]
-20	1.266 [32.16]	0.790 [20.07]	1.216 [30.89]	1.122 [28.50]	0.4722 [11.994]
-30	1.766 [44.86]	1.290 [32.77]	1.716 [43.59]	1.622 [41.20]	0.7222 [18.344]
-40	2.266 [57.56]	1.790 [45.47]	2.216 [56.29]	2.122 [53.90]	0.9722 [24.694]
-50	2.766 [70.26]	2.290 [58.17]	2.716 [68.99]	2.622 [66.60]	1.2222 [31.044]

TABLE 2

LPAM ASSY	BODY CALLOUT	TERMINAL SUB ASSY
LPAM-XX-01.0-X-XX-X-TR	LPAM-XX-01.0-XX-X	SUB-T-1M78-01.0-X-X
LPAM-XX-01.5-X-XX-X-TR	LPAM-XX-01.5-XX-X	SUB-T-1M78-01.5-X-X

TABLE 1
STACK HEIGHT

LPAM LEAD STYLE	LPAF LEAD STYLE	
	-03.0	-03.5
-01.0	.157 [4.00]	.177 [4.50]
-01.5	.177 [4.50]	.197 [5.00]

FIG 1
 LPAM-20-01.0-X-06-2-K-XR SHOWN
 (SOME CENTER FEATURES REMOVED FOR CLARITY)

NOTES:

- ⊙ REPRESENTS A CRITICAL DIMENSION.
- PUSH OUT FORCE .25LBS [1.11N].
- THIS DIMENSION IS TO BE CHECKED AT FOUR CORNERS: PINS A1, AX, N1, & NX, WHERE X IS THE NUMBER OF POSITIONS AND N IS THE NUMBER OF ROWS.
- NOTE DELETED.
- NOTE DELETED.
- NOTE DELETED.
- ATTACH LABEL TO EACH REEL.
- ⊙ MAXIMUM VARIATION BETWEEN ROWS: .003[0.08]. TO BE MEASURED AT FIRST AND LAST POSITIONS ONLY, ALL ROWS.
- ORDERS WILL BE PACKAGED ACCORDING TO THE SAMTEC PACKAGING EFFICIENCY STANDARDS (SPES) FOUND ON WWW.SAMTEC.COM.

UNLESS OTHERWISE SPECIFIED, DIMENSIONS ARE IN INCHES.

TOLERANCES ARE:
 DECIMALS ANGLES
 .XX: ±.01[0.3] 2°
 .XXX: ±.005[0.13]
 .XXXX: ±.0020[0.051]

PROPRIETARY NOTE
 THIS DOCUMENT CONTAINS CONFIDENTIAL AND PROPRIETARY INFORMATION AND ALL DESIGN, MANUFACTURING, REPRODUCTION, USE, PATENT RIGHTS AND SALES RIGHTS ARE EXPRESSLY RESERVED BY SAMTEC, INC. THIS DOCUMENT SHALL NOT BE DISCLOSED, IN WHOLE OR PART, TO ANY UNAUTHORIZED PERSON OR ENTITY NOR REPRODUCED, TRANSFERRED OR INCORPORATED IN ANY OTHER PROJECT IN ANY MANNER WITHOUT THE EXPRESS WRITTEN CONSENT OF SAMTEC, INC.

MATERIAL: DO NOT SCALE DRAWING SHEET SCALE: 1:0.4
 INSULATOR: LCP, COLOR: BLACK
 TERMINAL: COPPER ALLOY

520 PARK EAST BLVD, NEW ALBANY, IN 47150
 PHONE: 812-944-6733 FAX: 812-948-5047
 e-Mail info@SAMTEC.com code 55322

DESCRIPTION: LPAM TERMINAL ARRAY ASM

DWG. NO. LPAM-XX-XX.X-X-XX-X-K-XR

BY: KNOWLDEN 06/09/2009 SHEET 1 OF 3

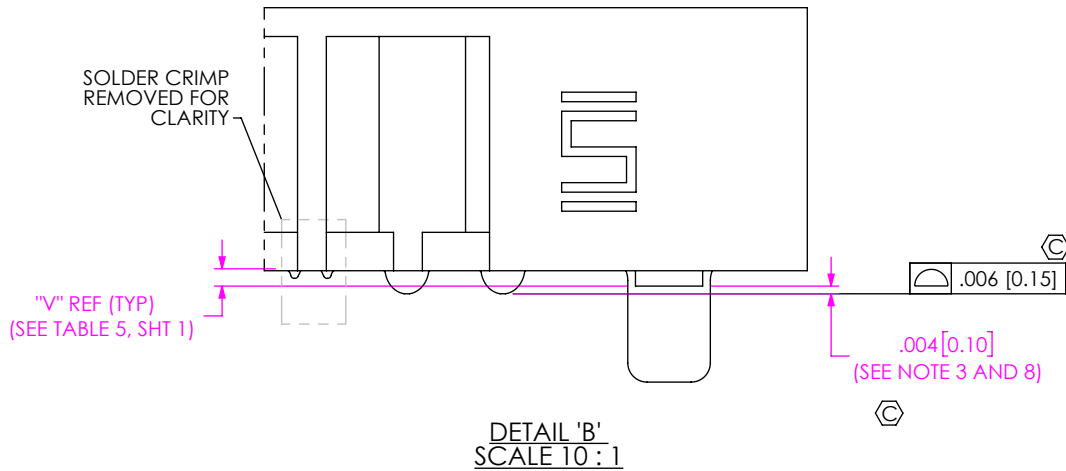
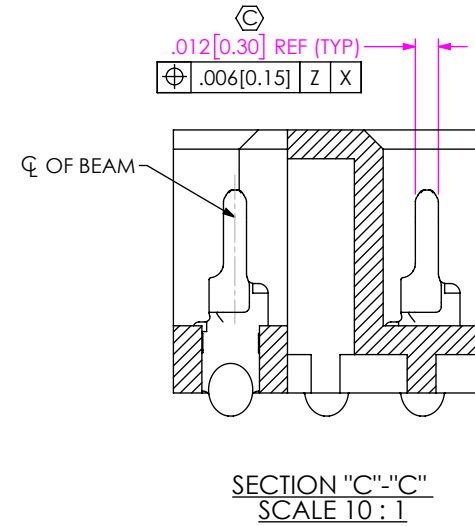
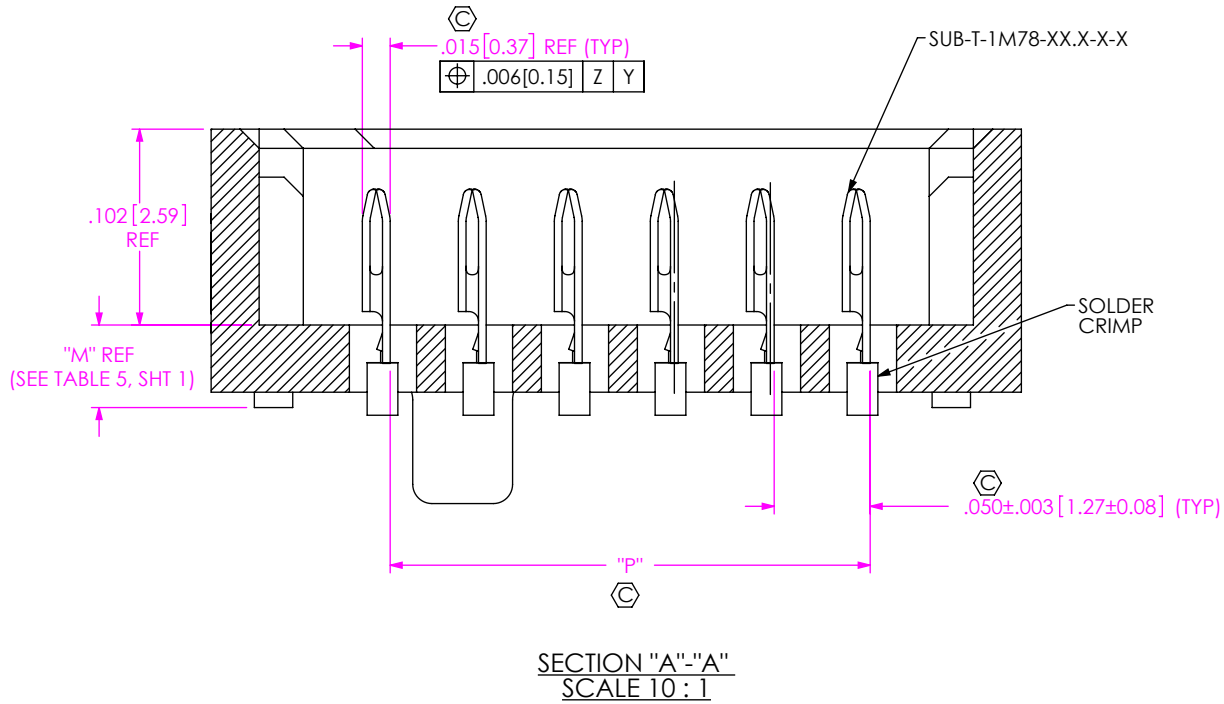

TABLE 6

-No. OF ROWS	"P"
-04	0.150 [3.81]
-06	0.250 [6.35]
-08	0.350 [8.89]
-10	0.450 [11.43]

PROPRIETARY NOTE
 THIS DOCUMENT CONTAINS CONFIDENTIAL AND PROPRIETARY INFORMATION AND ALL DESIGN, MANUFACTURING, REPRODUCTION, USE, PATENT RIGHTS AND SALES RIGHTS ARE EXPRESSLY RESERVED BY SAMTEC, INC. THIS DOCUMENT SHALL NOT BE DISCLOSED, IN WHOLE OR PART, TO ANY UNAUTHORIZED PERSON OR ENTITY NOR REPRODUCED, TRANSFERRED OR INCORPORATED IN ANY OTHER PROJECT IN ANY MANNER WITHOUT THE EXPRESS WRITTEN CONSENT OF SAMTEC, INC.

DO NOT SCALE DRAWING

SHEET SCALE: 2:1



520 PARK EAST BLVD, NEW ALBANY, IN 47150
 PHONE: 812-944-6733 FAX: 812-948-5047
 e-Mail: info@SAMTEC.com code 55322

DESCRIPTION:
 LPAM TERMINAL ARRAY ASM

DWG. NO.
 LPAM-XX-XX.X-X-XX-X-K-XR

BY: KNOWLDEN 06/09/2009 SHEET 2 OF 3

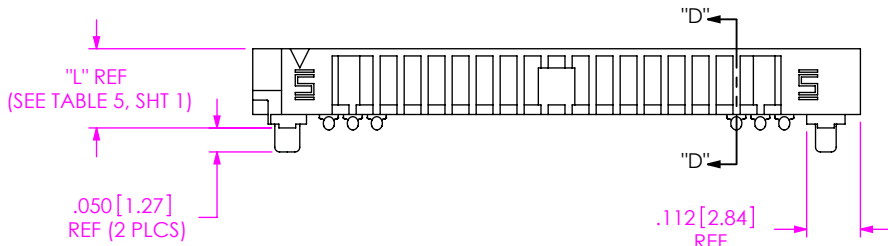
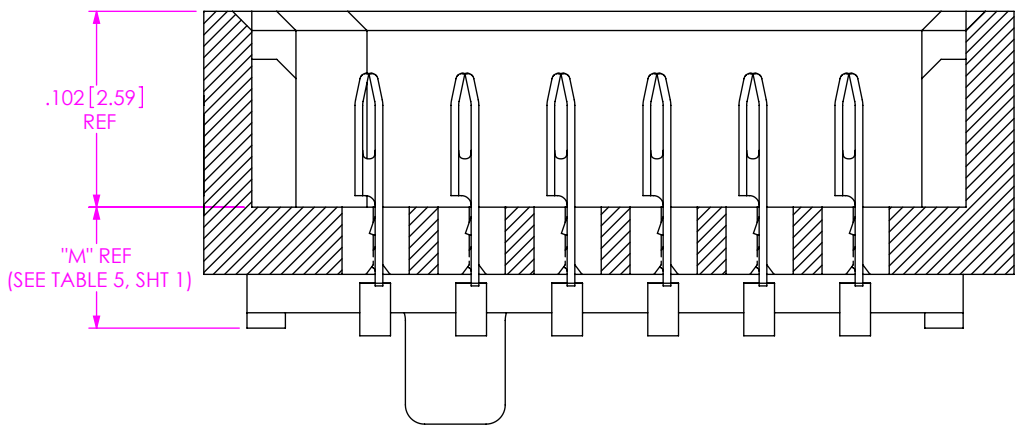

FIG 2
LPAM-20-01.5-X-06-2-K-XR SHOWN
(SOME CENTER FEATURES REMOVED FOR CLARITY)



SECTION "D"-"D"
SCALE 10:1

TABLE 7

ROWS	DOT APPLICATOR POLYIMIDE TAPE CALLOUT	"R"	"S"	"T"				
				10 POS.	20 POS.	30 POS.	*40 POS.	*50 POS.
-04	K-DOT-.354-.469-.005	0.354 [8.99]	0.016 [0.41]	0.206 [5.23]	0.456 [11.58]	0.706 [17.93]	0.956 [24.28]	1.206 [30.63]
-06	K-DOT-.460-.550-.005	0.460 [11.68]	0.019 [0.48]	0.153 [3.89]	0.403 [10.24]	0.653 [16.59]	0.903 [22.94]	1.153 [29.29]
-08	K-DOT-.551-.625-.010	0.551 [14.00]	0.015 [0.37]	0.108 [2.74]	0.358 [9.09]	0.608 [15.44]	0.858 [21.79]	1.108 [28.14]
-10	K-DOT-.649-.750-.005	0.649 [16.48]	0.014 [0.34]	0.059 [1.50]	0.309 [7.85]	0.559 [14.20]	0.809 [20.55]	1.059 [26.90]

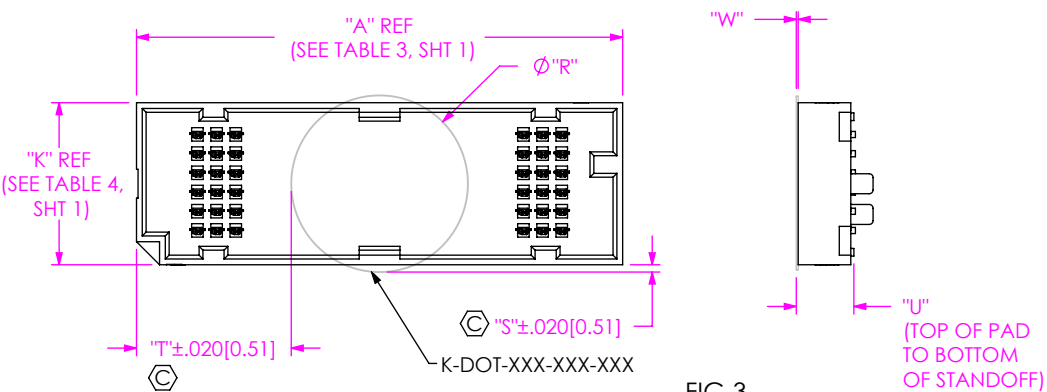

FIG 3
-K POLYIMIDE PAD
(USE K-DOT-XXX-XXX-XXX)
LPAM-20-01.0-X-06-2-K-XR SHOWN
(SOME CENTER FEATURES REMOVED FOR CLARITY)

TABLE 8

ROW	"U"		"W"
	LEAD STYLE		
	-1.0	-1.5	
-04	.150 [3.81]	.170 [4.32]	.005 [0.13]
-06	.150 [3.81]	.170 [4.32]	.005 [0.13]
-08	.155 [3.94]	.175 [4.45]	.010 [0.25]
-10	.150 [3.81]	.170 [4.32]	.005 [0.13]

PROPRIETARY NOTE
THIS DOCUMENT CONTAINS CONFIDENTIAL AND PROPRIETARY INFORMATION AND ALL DESIGN, MANUFACTURING, REPRODUCTION, USE, PATENT RIGHTS AND SALES RIGHTS ARE EXPRESSLY RESERVED BY SAMTEC, INC. THIS DOCUMENT SHALL NOT BE DISCLOSED, IN WHOLE OR PART, TO ANY UNAUTHORIZED PERSON OR ENTITY NOR REPRODUCED, TRANSFERRED OR INCORPORATED IN ANY OTHER PROJECT IN ANY MANNER WITHOUT THE EXPRESS WRITTEN CONSENT OF SAMTEC, INC.

DO NOT SCALE DRAWING
SHEET SCALE: 2:1





520 PARK EAST BLVD, NEW ALBANY, IN 47150
PHONE: 812-944-6733 FAX: 812-948-5047
e-Mail info@SAMTEC.com code 55322

DESCRIPTION:
LPAM TERMINAL ARRAY ASM
DWG. NO.
LPAM-XX-XX.X-X-XX-X-K-XR
BY: KNOWLDEN 06/09/2009 SHEET 3 OF 3

Looking for pricing, stock, or lifecycle information?

Click below to explore more details on WIN SOURCE:

-  [View LPAM-20-01.5-S-08-1-K-TR on WIN SOURCE](#)
-  [Samtec Inc. Information](#)

Optimize Your Supply Chain with WIN SOURCE Solutions

-  Global Sourcing Solution
-  Obsolete Management
-  Cost Control Management
-  Shortage Management
-  Alternative Solution
-  Excess Inventory Management