



**THE DATASHEET OF  
TB524-100.0M**





## Improved Performance 5x7mm TB / TVB Model Series

### TCXO / VCTCXO

# CONNOR WINFIELD



2111 Comprehensive Drive

Aurora, Illinois 60505

Phone: 630-851-4722

Fax: 630-851-5040

www.conwin.com

### Description:

Connor-Winfield's TBxxx and TVBxxx series are 5x7mm TCXO and VCTCXO products with exceptional frequency stability and low phase noise.

Similar to our Txxx / TVxxx series, these devices are quieter, smoother over temperature and are available at higher frequencies.

Using the latest analog TCXO technology, the TBxxx and TVBxxx series have improved phase noise and frequency stability performance and are available in 4-pad or 10-pad surface mount footprints.

These products are designed for such applications as IEEE 1588 PTP and Synchronous Ethernet.



### Features:

- Frequency Stabilities Available:
  - +/-0.28 ppm (10 to 50 MHz)
  - +/-0.50 ppm, +/-1.00 ppm or +/-2.00 ppm (10 to 100 MHz)
- Temperature Ranges Available:
  - 0 to 85°C, 0 to 70°C, -40 to 85°C or -20 to 70°C
- Packages Available:
  - TB - Series: 5 x 7mm - 10 Pad
  - TVB - Series: 5 x 7mm - 4 Pad
- 3.3 Vdc Operation
- Output Logic: LVCMOS or Clipped Sinewave
- Fixed Frequency - TCXO
- Voltage Controlled - VCTCXO
- Low Jitter <0.50 ps RMS
- Low Phase Noise
- Tri-State Enable/Disable: (TB - Model Series Only)
- Tape and Reel Packaging
- RoHS Compliant / Lead Free

### Applications:

- IEEE 1588 Applications
- Synchronous Ethernet slave clocks, ITU-T G.8262 EEC options 1 & 2
- Compliant to Stratum 3, GR-1244-CORE & GR-253-CORE
- Wireless Communications
- Small Cells
- Test and Measurement
- GPS Applications

### Standard Frequencies Available \*

\* 10, 12.8, 19.2, 19.44, 20, 25, 40, 50, 52, 54, 80 and 100 MHz  
Available frequencies from the factory for small quantity orders or quick delivery.  
Additional frequencies are available.

\*\* Not all options  
available at  
Digi-Key

### Ordering Information

TVB	5	0	4	- 010.0M
Type / Package TCXO / VCTCXO Series  TB = 5.0x7.0 mm 10 Pads TVB = 5.0x7.0 mm 4 Pads	Temperature Range  3 = 0 to 85 °C 5 = 0 to 70 °C 6 = -40 to 85 °C 7 = -20 to 70 °C	Frequency Stability  0 = ±0.28 ppm 1 = ±0.50 ppm 2 = ±1.00 ppm 3 = ±2.00 ppm	Features  2 = TCXO, LVCMOS, 3.3 Vdc 3 = TCXO, Clipped Sinewave, 3.3 Vdc 4 = VCTCXO, LVCMOS, 3.3 Vdc 5 = VCTCXO, Clipped Sinewave, 3.3 Vdc 9 = VCTCXO, LVCMOS, 3.3V with reduced pull range	Output Frequency  Frequency Format -xxx.xM Min* -xxx.xxxxxM Max* *Minimum of 1 digit after the decimal point, and Maximum of 6

Example: Part Number

TVB504-010.0M = 5x7mm 4 pad package, ±0.28 ppm, 0 to 70 °C, 3.3 Vdc, LVCMOS Output, VCTCXO  
TB715-012.8M = 5x7mm 10 pad package, ±0.50 ppm, -20 to 70 °C, 3.3 Vdc, Clipped Sinewave Output, VCTCXO  
TB522-050.0M = 5x7mm 10 pad package, ±1.0 ppm, 0 to 70 °C, 3.3 Vdc, LVCMOS Output, TCXO  
TVB602-010.0M = 5x7mm 4 pad package, ±0.28 ppm, -40 to 85 °C, 3.3 Vdc, LVCMOS Output, TCXO





## Absolute Maximum Ratings

Parameter	Minimum	Nominal	Maximum	Units	Notes
Storage Temperature	-55	-	95	°C	
Supply Voltage (Vcc)	-0.5	-	6.0	Vdc	
Input Voltage	-0.5	-	Vcc + 0.5	Vdc	

## Operating Specifications

Parameter	Minimum	Nominal	Maximum	Units	Notes
Output Frequency (Fo)					
Models TBx0x, TVBx0x	10	-	50	MHz	
Models TBx1x, TVBx1x	10	-	100	MHz	
Models TBx2x, TVBx2x	10	-	100	MHz	
Models TBx3x, TVBx3x	10	-	100	MHz	
Operating Temperature Range	(See Ordering Information for full part number)				
Models TB3xx, TVB3xx	0	-	85	°C	
Models TB5xx, TVB5xx	0	-	70	°C	
Models TB6xx, TVB6xx	-40	-	85	°C	
Models TB7xx, TVB7xx	-20	-	70	°C	
Frequency Calibration @ 25 °C	-1.0	-	1.0	ppm	1
Frequency Stability (See Ordering Information for full part number) Per STRATUM 3 GR-1244-CORE	<b>Frequency Stability ±0.28 ppm is only available in the frequency range of 10 to 50 MHz.</b>				
Models TBx0x, TVBx0x	-0.28	-	0.28	ppm	2
Holdover Stability	-0.32	-	0.32	ppm	3
Constant Temperature Stability	-40	-	40	ppb	Over 24 Hrs.
Frequency Stability	(See Ordering Information for full part number)				
Models TBx1x, TVBx1x	-0.50	-	0.50	ppm	2
Models TBx2x, TVBx2x	-1.00	-	1.00	ppm	2
Models TBx3x, TVBx3x	-2.00	-	2.00	ppm	2
Frequency vs. Load Stability	-0.05	-	0.05	ppm	±5%
Frequency vs. Voltage Stability	-0.05	-	0.05	ppm	±5%
Static Temperature Hysteresis	-	-	0.40	ppm	4
Freq. shift after reflow soldering	-1.0	-	1.0	ppm	5
Long Term Stability	-1.0	-	1.0	ppm	6
Aging					
per Life (20 Years)	-3.0	-	3.0	ppm	
per Day	-40	-	40	ppb	
Total Frequency Tolerance	-4.6	-	4.6	ppm	7
Supply Voltage (Vcc)	3.135	3.30	3.465	Vdc	
Supply Current (Icc)					
LVCMOS (10 to 52 MHz)	-	2.1	6.0	mA	
LVCMOS (>52 to 100 MHz)	-	-	12	mA	
Clipped Sine (10 to 52 MHz)	-	1.3	2.9	mA	
Clipped Sine (>52 to 100 MHz)	-	-	12	mA	
Jitter:					
Period Jitter	-	3.0	5.0	ps RMS	
Integrated Phase Jitter (12K to Fo/2)	-	0.3	1.0	ps RMS	8
Allan Deviation (1s) Fo=10.0 MHz	-	1.0E-10	-		
Typical SSB Phase Noise					
For Fo	10.0 MHz	50.0 MHz	100.0 MHz		
@ 10 Hz offset	-98	-70	-60	dBc/Hz	
@ 100 Hz offset	-125	-100	-91	dBc/Hz	
@ 1 KHz offset	-143	-122	-119	dBc/Hz	
@ 10 KHz offset	-151	-145	-142	dBc/Hz	
@ 100 KHz offset	-152	-150	-153	dBc/Hz	
@ 1 MHz offset	-155	-152	-153	dBc/Hz	
Start-Up Time	-	-	10	ms	



## Control Voltage Input Characteristics

Parameter	Minimum	Nominal	Maximum	Units	Notes
Control Voltage	0.3	1.65	3.0	V	
Frequency Pullability					
Pull Range Options 4 and 5:	±10	±12	-	ppm	
Pull Range Option 9:	±5	±6	±8	ppm	
Pull Slope (Vc=1.65V)					
Pull Range Options 4 and 5:	-	8.00	-	ppm/V	
Pull Range Option 9:	-	4.50	-	ppm/V	
Control Voltage Slope	Positive Slope				
Monotonic Linearity	-	-	5	%	
Input Impedance	100K	-	-	Ohm	
Modulation Bandwidth (3dB)	10	-	-	KHz	

## OE Enable /Disable Input Characteristics (Pad 8) TB Series only

Parameter	Minimum	Nominal	Maximum	Units	Notes
Enable Voltage (High)	70%Vcc	-	-	Vdc	9
Disable Voltage (Low)	-	-	30%Vcc	Vdc	9
Function	Output				
Low:	Disabled (High Impedance)				
High or Open:	Enabled				

## LVC MOS Output Characteristics

Parameter	Minimum	Nominal	Maximum	Units	Notes
Load (CL)	-	15	-	pF	10
Voltage (High) (Voh)	90%Vcc	-	-	Vdc	
(Low) (Vol)	-	-	10%Vcc	Vdc	
Current (High) (Ioh)	-4	-	-	mA	
(Low) (Iol)	-	-	4	mA	
Duty Cycle at 50% of Vcc (Fo<70MHz)	45	50	55	%	
Duty Cycle at 50% of Vcc (Fo ≥ 70MHz)	40	45	50	%	
Rise / Fall Time 10% to 90%	-	4	8	ns	

## Clipped Sinewave Output Characteristics

Parameter	Minimum	Nominal	Maximum	Units	Notes
Load (RC)					11
Output Load Resistance	-	10K	-	Ohm	12
Output Load Capacitance	-	10	-	pF	
Output Voltage (< 40 MHz)	1.0	1.2	-	V	pk-pk
Output Voltage (≥ 40 MHz)	0.8	1.0	-	V	pk-pk
Output Impedance	-	200	-	Ohms	

## Package Characteristics

Package	Hermetically sealed ceramic package with grounded metal cover
---------	---

## Environmental Characteristics

Vibration:	Vibration per Mil Std 883E Method 2007.3 Test Condition A.
Shock:	Mechanical Shock per Mil Std 883E Method 2002.4 Test Condition B.
Soldering Process:	RoHS compliant lead free. See soldering profile on page 6.

### Notes:

- Initial calibration @ 25°C. ±2°C, for VCTCXO's Vc = 1.65V. Specifications at time of shipment
- Frequency stability vs. change in temperature.  $[\pm(F_{max}-F_{min})/(2 \cdot F_0)]$ . For VCTCXO, Vc = 1.65Vdc
- Inclusive of frequency stability, supply voltage change (±1%), aging, for 24 hours. Per STRATUM 3 GR-1244-CORE.
- Frequency change after reciprocal temperature ramped over the operating range. Frequency measured before and after at 25°C
- Two consecutive solder reflows after 1 hour recovery @ 25°C.
- Frequency drift over 1 year @ 25°C.
- Inclusive of calibration @ 25°C, frequency vs. change in temperature, change in supply voltage (±5%), load change (±5%), reflow soldering process and 20 years aging.
- For Fo<40MHz, BW=12kHz to Fo/2, for Fo>40MHz, BW=12kHz to 20MHz
- Output is active with Pad 8 not connected. Leave Pad 8 open if disable function is not required. When disabled, output stage is off but oscillator and compensation circuits are still powered (current consumption <2 mA)
- Attention: To achieve optimal frequency stability, and in some cases to meet the specification stated on this data sheet, it is required that the circuit connected to this TCXO output must have the equivalent input capacitance that is specified by the nominal load capacitance. Deviations from the nominal load capacitance will have a graduated effect on the stability of approximately 20 ppb per pF load difference.
- Load components are required for proper operation of the device.
- Output is AC coupled.

Bulletin	<b>Tx380</b>
Page	<b>3 of 6</b>
Revision	<b>11</b>
Date	<b>30 Nov 2022</b>



## TB Series Package Outline

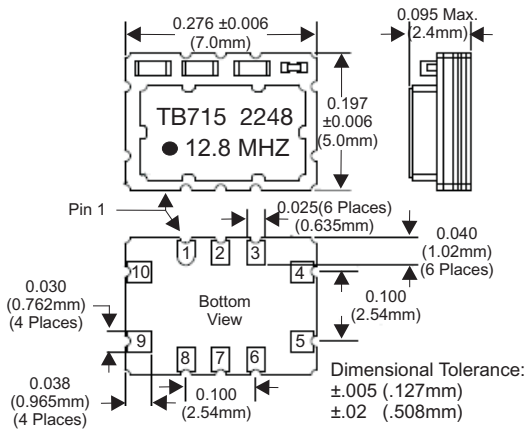

## TB Series Suggested Pad Layout

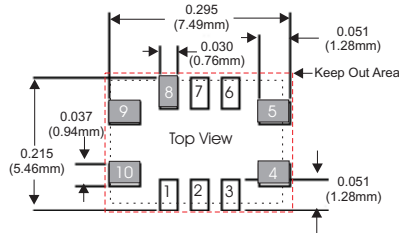

\* Do not route any traces in the keep out area. It is recommended the next layer under the keep out area is to be ground plane.

## TB Series Pad Connections

- 1: Do Not Connect
- 2: Do Not Connect
- 3: Do Not Connect
- 4: Ground
- 5: Output
- 6: Do Not Connect
- 7: Do Not Connect
- 8: Enable / Disable (OE)
- 9: Supply Voltage (Vcc)
- 10: VCTCXO: Control Voltage (Vc)  
TCXO: N/C

## TVB Series Package Outline

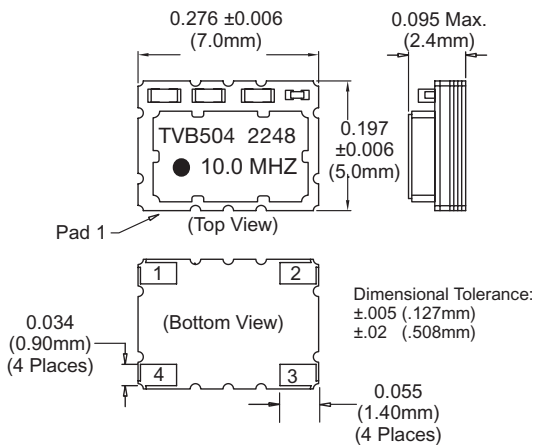

## TVB Series Suggested Pad Layout

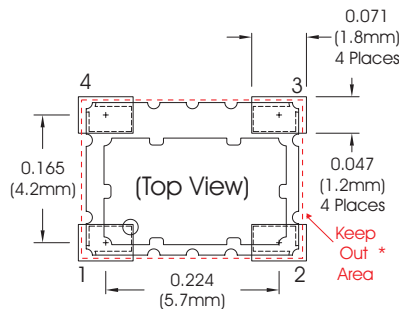

\* Do not route any traces in the keep out area. It is recommended the next layer under the keep out area is to be ground plane.

## TVB Series Pad Connections

- 1: VCTCXO: Voltage Control (Vc)  
TCXO: N/C
- 2: Ground
- 3: Output
- 4: Supply (Vcc)

## Marking Information

The following are examples of possible marking configurations

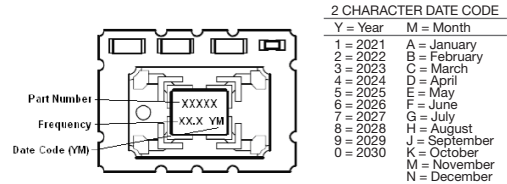
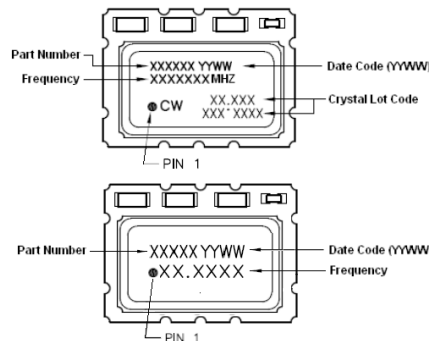
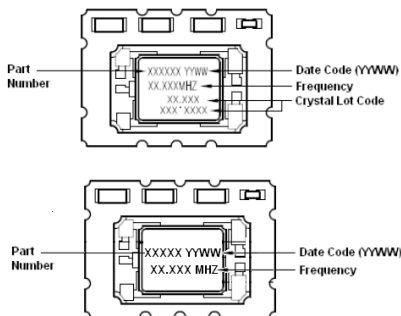

2 CHARACTER DATE CODE	
Y = Year	M = Month
1 = 2021	A = January
2 = 2022	B = February
3 = 2023	C = March
4 = 2024	D = April
5 = 2025	E = May
6 = 2026	F = June
7 = 2027	G = July
8 = 2028	H = August
9 = 2029	J = September
0 = 2030	K = October
	M = November
	N = December

Bulletin	<b>Tx380</b>
Page	<b>4 of 6</b>
Revision	<b>11</b>
Date	<b>30 Nov 2022</b>

## TB Series Design Recommendations

## TVB Series Design Recommendations

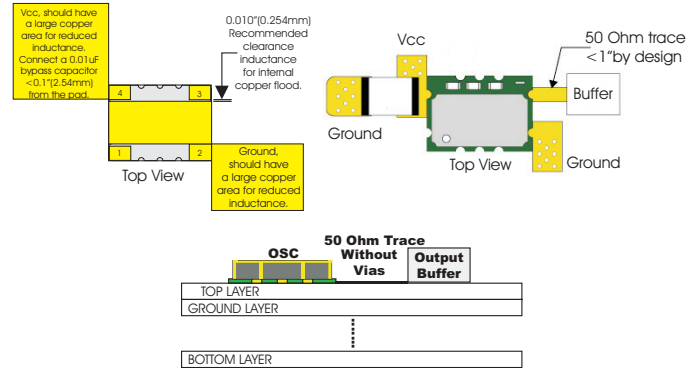
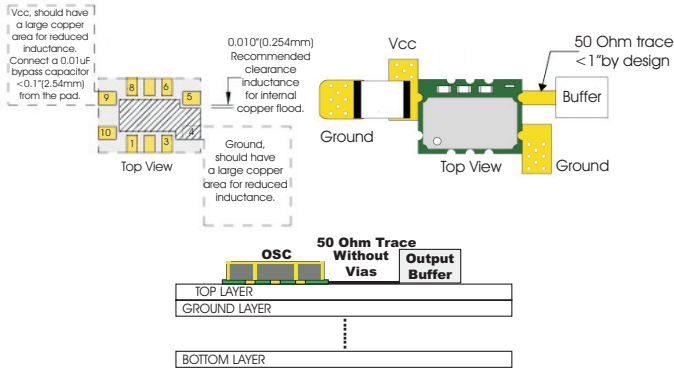

## TB Series LVC MOS Test Circuit

## TVB Series LVC MOS Test Circuit

## LVC MOS Output Waveform

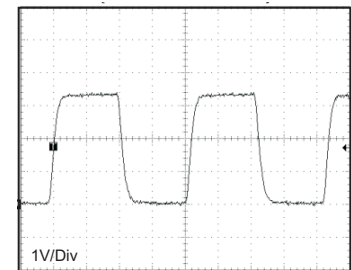
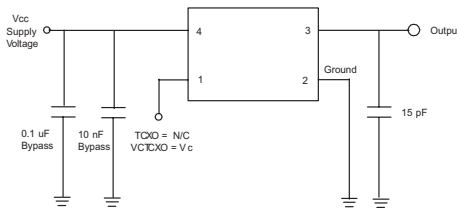
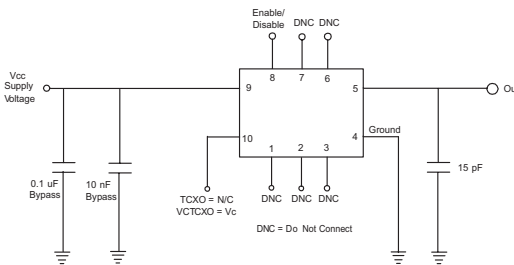

## TB Series Clipped Sinewave Test Circuit

## TVB Series Clipped Sinewave Test Circuit

## Clipped Sinewave Output Waveform

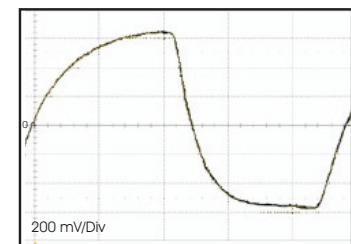
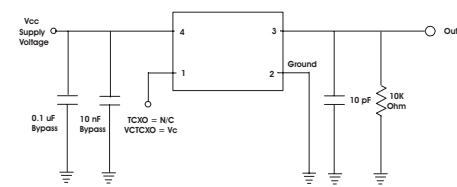
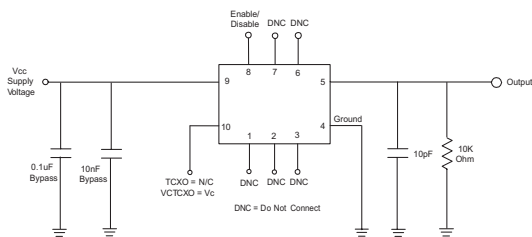

Note: The clipped sinewave output is AC coupled

Bulletin	<b>Tx380</b>
Page	<b>5 of 6</b>
Revision	<b>11</b>
Date	<b>30 Nov 2022</b>

## Typical Phase Noise Fo=10MHz

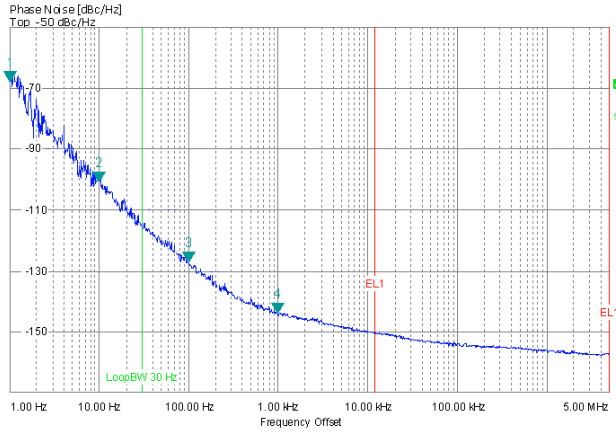

MTIE

## TIE

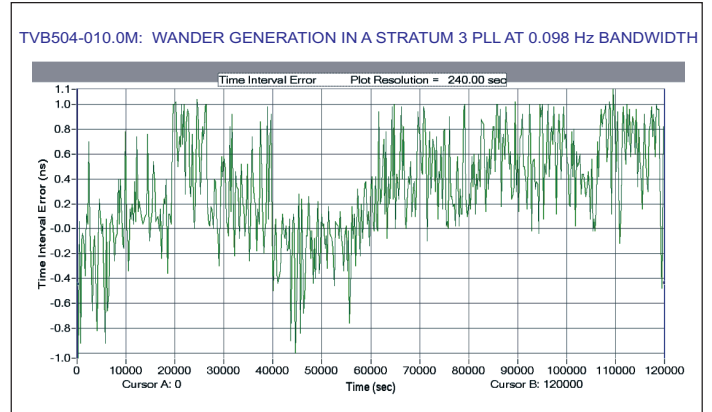

TDEV

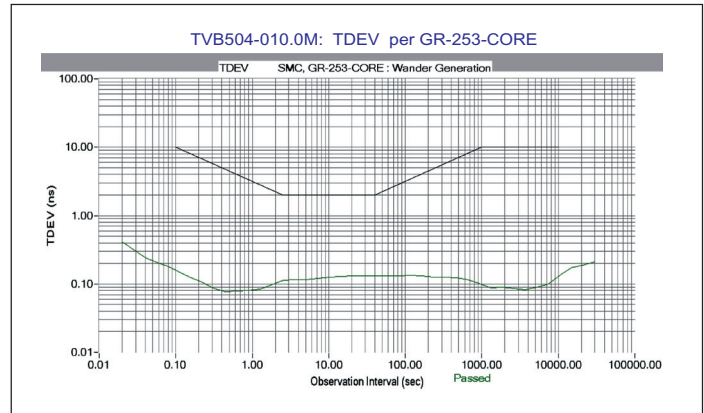
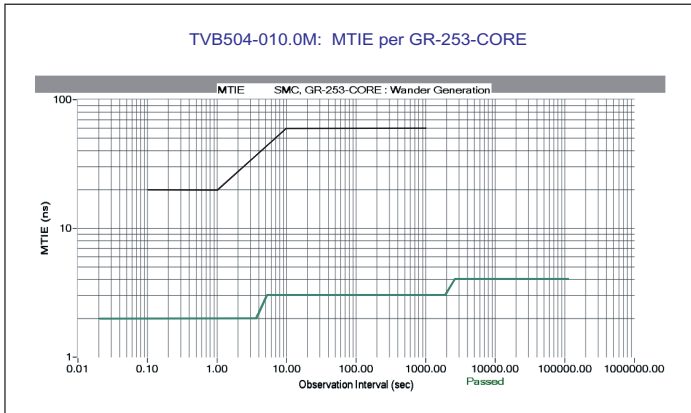

## 5x7mm Tape and Reel Information

MEETS EIA-481A AND EIAJ-1009B  
 700 PCS/REEL MAXIMUM.

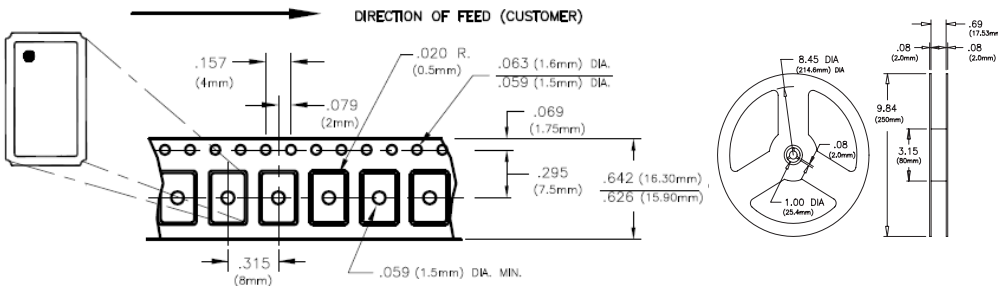

## Revision History

Revision	Date	Description
00	10/23/12	Data sheet released 10/23/12
01	11/12/12	Added Digi-Key
02	02/25/13	Increased frequency range to 100 MHz
03	12/04/13	Updated available Frequencies
04	02/07/14	Removed note from Output Freq
05	02/11/14	Updated specifications
06	04/29/15	Added Additional Package Height for Select Frequencies
07	10/20/15	Updated Allan Deviation specification
08	09/07/16	Updated Phase Noise Plot and Control Voltage Specs
09	09/15/16	Updated Ordering Information
10	08/09/18	Updates to T&R, Package Dimensions, Added Marking Info
11	11/30/22	Duty cycle specification for high frequencies

## Solder Profile

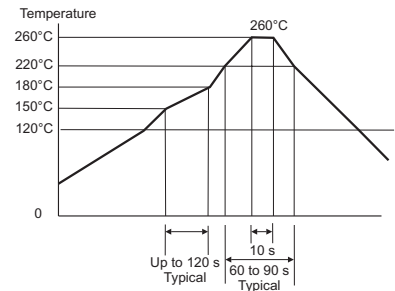

Meets IPC/JEDEC J-STD-020C

Bulletin	<b>Tx380</b>
Page	<b>6 of 6</b>
Revision	<b>11</b>
Date	<b>30 Nov 2022</b>

## Looking for pricing, stock, or lifecycle information?

Click below to explore more details on WIN SOURCE:

- ⊖ [View TB524-100.0M on WIN SOURCE](#)
- ⊖ [Connor-Winfield Corporation Information](#)

## Optimize Your Supply Chain with WIN SOURCE Solutions

- ✓ Global Sourcing Solution
- ✓ Obsolete Management
- ✓ Cost Control Management
- ✓ Shortage Management
- ✓ Alternative Solution
- ✓ Excess Inventory Management