



# TMP117 High-Accuracy, Low-Power, Digital Temperature Sensor With SMBus™- and I<sup>2</sup>C-Compatible Interface

## 1 Features

- TMP117 high-accuracy temperature sensor
  - $\pm 0.1$  °C (maximum) from  $-20$  °C to  $50$  °C
  - $\pm 0.15$  °C (maximum) from  $-40$  °C to  $70$  °C
  - $\pm 0.2$  °C (maximum) from  $-40$  °C to  $100$  °C
  - $\pm 0.25$  °C (maximum) from  $-55$  °C to  $125$  °C
  - $\pm 0.3$  °C (maximum) from  $-55$  °C to  $150$  °C
- Operating temperature range:  $-55$  °C to  $150$  °C
- Low power consumption:
  - $3.5$ - $\mu$ A, 1-Hz conversion cycle
  - $150$ -nA shutdown current
- Supply range:
  - $1.7$  V to  $5.5$  V from  $-55$  °C to  $70$  °C
  - $1.8$  V to  $5.5$  V from  $-55$  °C to  $150$  °C
- 16-bit resolution:  $0.0078$ °C (1 LSB)
- Programmable temperature alert limits
- Selectable averaging
- Digital offset for system correction
- General-purpose EEPROM: 48 bits
- NIST traceability
- SMBus™, I<sup>2</sup>C interface compatibility
- Medical grade: meets ASTM E1112 and ISO 80601-2-56
- RTDs replacement: PT100, PT500, PT1000

## 2 Applications

- Electronic thermometers
- Wireless environmental sensors
- Thermostats
- Automotive test equipment
- Wearable fitness and activity monitors
- Cold chain asset tracking
- Gas meters and heat meters
- Temperature transmitters

## 3 Description

The TMP117 is a high-precision digital temperature sensor. It is designed to meet ASTM E1112 and ISO 80601 requirements for electronic patient thermometers. The TMP117 provides a 16-bit temperature result with a resolution of  $0.0078$  °C and an accuracy of up to  $\pm 0.1$  °C across the temperature range of  $-20$  °C to  $50$  °C with no calibration. The TMP117 has an interface that is I<sup>2</sup>C- and SMBus™-compatible, programmable alert functionality, and the device can support up to four devices on a single bus. Integrated EEPROM is included for device programming with an additional 48-bits memory available for general use.

The low power consumption of the TMP117 minimizes the impact of self-heating on measurement accuracy. The TMP117 operates from  $1.7$  V to  $5.5$  V and typically consumes  $3.5$   $\mu$ A.

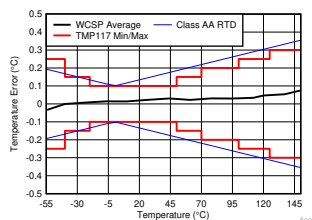
For non-medical applications, the TMP117 can serve as a single chip digital alternative to a Platinum RTD. The TMP117 has an accuracy comparable to a Class AA RTD, while only using a fraction of the power of the power typically needed for a PT100 RTD. The TMP117 simplifies the design effort by removing many of the complexities of RTDs such as precision references, matched traces, complicated algorithms, and calibration.

The TMP117 units are 100% tested on a production setup that is NIST traceable and verified with equipment that is calibrated to ISO/IEC 17025 accredited standards.

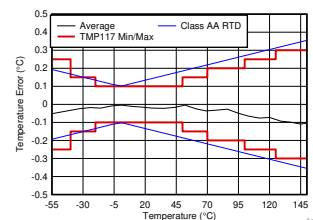
### Device Information<sup>(1)</sup>

PART NUMBER	PACKAGE	BODY SIZE (NOM)
TMP117	WS0N (6)	2.00 mm × 2.00 mm
	DSBGA (6)	1.53 mm × 1.00 mm

- (1) For all available packages, see the package option addendum at the end of the data sheet.



**YBG Temperature Accuracy**



**DRV Temperature Accuracy**



## Table of Contents

<b>1 Features</b> .....	1	7.4 Device Functional Modes.....	14
<b>2 Applications</b> .....	1	7.5 Programming.....	18
<b>3 Description</b> .....	1	7.6 Register Map.....	25
<b>4 Revision History</b> .....	2	<b>8 Application and Implementation</b> .....	33
<b>5 Pin Configuration and Functions</b> .....	4	8.1 Application Information.....	33
<b>6 Specifications</b> .....	5	8.2 Typical Application.....	33
6.1 Absolute Maximum Ratings .....	5	<b>9 Power Supply Recommendations</b> .....	35
6.2 ESD Ratings .....	5	<b>10 Layout</b> .....	36
6.3 Recommended Operating Conditions .....	5	10.1 Layout Guidelines.....	36
6.4 Thermal Information .....	5	10.2 Layout Examples.....	37
6.5 Electrical Characteristics .....	6	<b>11 Device and Documentation Support</b> .....	39
6.6 Switching Characteristics .....	7	11.1 Documentation Support.....	39
6.7 Two-Wire Interface Timing .....	7	11.2 Receiving Notification of Documentation Updates..	39
6.8 Timing Diagram.....	8	11.3 Support Resources.....	39
6.9 Typical Characteristics.....	8	11.4 Trademarks.....	39
<b>7 Detailed Description</b> .....	11	11.5 Electrostatic Discharge Caution.....	39
7.1 Overview.....	11	11.6 Glossary.....	39
7.2 Functional Block Diagrams.....	11	<b>12 Mechanical, Packaging, and Orderable Information</b> .....	39
7.3 Feature Description.....	12		

## 4 Revision History

NOTE: Page numbers for previous revisions may differ from page numbers in the current version.

### Changes from Revision C (April 2021) to Revision D (September 2022) Page

- Changed device numbers in the *Bus Overview* section..... 20

### Changes from Revision B (March 2019) to Revision C (April 2021) Page

- Updated the numbering format for tables, figures, and cross-references throughout the document..... 1
- Changed minimum supply rating to 1.7 V for restricted temperature range..... 1
- Updated minimum supply voltage in Description..... 1
- Added 1.7 V supply rating for in Recommended Operating Conditions..... 5
- Updated Long term stability and drift conditions from 300 hrs to 1000 hrs..... 6
- Corrected ALERT Pin Output Voltage vs Pin Sink Current labels..... 8
- Added I2C behavior notes..... 20
- Updated Power Supply Recommendations to reflect new 1.7 V supply rating..... 35
- Updated documentation links..... 39

### Changes from Revision A (October 2018) to Revision B (March 2019) Page

- Moved the medical grade specs and RTD replacement information to the *Features* section .....
- Changed application bullets..... 1
- Added YBG (DSBGA) package information..... 1
- Added YBG package accuracy image..... 1
- Changed accuracy image to indicate DRV package..... 1
- Changed TJ(MAX) from 150 °C to 155 °C..... 5
- Added YBG package thermal information..... 5
- Added YBG package temperature accuracy chart..... 8
- Changed conversion cycle timing diagram..... 14
- Changed one-shot timing diagram with AVG[1:0] = 00..... 15
- Changed alert mode timing diagram..... 16
- Changed therm mode timing diagram..... 17
- Changed write word command timing diagram..... 22
- Changed read word command timing diagram..... 22
- Changed SMBus alert timing diagram..... 22

• Changed general-call reset command timing diagram.....	22
• Updated the formatting in the <i>Register Map</i> section.....	25
• Added return links to the register descriptions.....	25
• Fixed access type code location and descriptions.....	25
• Changed typical connections diagram.....	33
• Added YBG package layout example.....	37

---

<b>Changes from Revision * (June 2018) to Revision A (October 2018)</b>	<b>Page</b>
---	-------------

---

• Changed device status from Advanced Information to Production Data .....	1
• Changed shutdown current from: 250 nA to: 150 nA .....	1

---

## 5 Pin Configuration and Functions

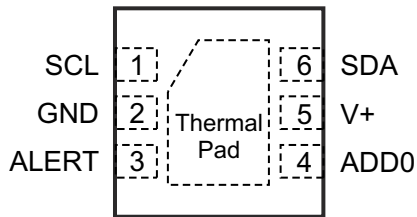


Figure 5-1. DRV Package 6-Pin WSON Top View

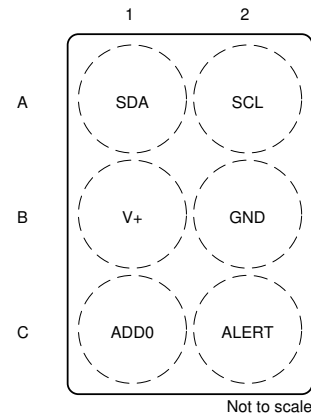


Figure 5-2. YBG Package 6-Pin DSBGA Top View

Table 5-1. Pin Functions

NAME	PIN		TYPE	DESCRIPTION
	WSON	DSBGA		
ADD0	4	C1	I	Address select. Connect to GND, V+, SDA, or SCL.
ALERT	3	C2	O	Over temperature alert or data-ready signal. This open-drain output requires a pullup resistor.
GND	2	B2	—	Ground
SCL	1	A2	I	Serial clock
SDA	6	A1	I/O	Serial data input and open-drain output. Requires a pullup resistor.
V+	5	B1	I	Supply voltage

## 6 Specifications

### 6.1 Absolute Maximum Ratings

Over free-air temperature range unless otherwise noted<sup>(1)</sup>

		MIN	MAX	UNIT
Supply voltage	V+	-0.3	6	V
Voltage at	SCL, SDA, ALERT and ADD0	-0.3	6	V
Operating junction temperature, T <sub>J</sub>		-55	155	°C
Storage temperature, T <sub>stg</sub>		-65	155	°C

- (1) Stresses beyond those listed under *Absolute Maximum Ratings* may cause permanent damage to the device. These are stress ratings only, which do not imply functional operation of the device at these or any other conditions beyond those indicated under *Recommended Operating Conditions*. Exposure to absolute-maximum-rated conditions for extended periods may affect device reliability.

### 6.2 ESD Ratings

			VALUE	UNIT
V <sub>(ESD)</sub>	Electrostatic discharge	Human-body model (HBM), per ANSI/ESDA/JEDEC JS-001 <sup>(1)</sup>	±2000	V
		Charged-device model (CDM), per JEDEC specification JESD22-C101 <sup>(2)</sup>	±1000	

- (1) JEDEC document JEP155 states that 500-V HBM allows safe manufacturing with a standard ESD control process.  
 (2) JEDEC document JEP157 states that 250-V CDM allows safe manufacturing with a standard ESD control process.

### 6.3 Recommended Operating Conditions

		MIN	NOM	MAX	UNIT
V+	Supply voltage, T <sub>A</sub> = -55 °C to 150 °C	1.8	3.3	5.5	V
V+	Supply voltage, T <sub>A</sub> = -55 °C to 70 °C	1.7		5.5	V
V <sub>I/O</sub>	SCL, SDA, ALERT and ADD0	0		5.5	V
T <sub>A</sub>	Operating free-air temperature	-55		150	°C

### 6.4 Thermal Information

THERMAL METRIC <sup>(1)</sup>		TMP117		UNIT
		YBG (DSBGA)	DRV (WSON)	
		6 PINS	6 PINS	
R <sub>θJA</sub>	Junction-to-ambient thermal resistance	133.2	70.7	°C/W
R <sub>θJC(top)</sub>	Junction-to-case (top) thermal resistance	1.0	82.3	°C/W
R <sub>θJC(bot)</sub>	Junction-to-case (bottom) thermal resistance	N/A	11.7	°C/W
R <sub>θJB</sub>	Junction-to-board thermal resistance	40.9	35.4	°C/W
ψ <sub>JT</sub>	Junction-to-top characterization parameter	0.1	2.2	°C/W
ψ <sub>JB</sub>	Junction-to-board characterization parameter	40.7	35.3	°C/W
M <sub>T</sub>	Thermal Mass	0.8	5.1	mJ/°C

- (1) For more information about traditional and new thermal metrics, see the *IC Package Thermal Metrics* application report, [SPRA953](#).

## 6.5 Electrical Characteristics

Over free-air temperature range and  $V_+ = 1.7\text{ V}$  to  $5.5\text{ V}$  for  $T_A = -55\text{ °C}$  to  $70\text{ °C}$ , or  $V_+ = 1.8\text{ V}$  to  $5.5\text{ V}$  for  $T_A = -55\text{ °C}$  to  $150\text{ °C}$  (unless otherwise noted); Typical specifications are at  $T_A = 25\text{ °C}$  and  $V_+ = 3.3\text{ V}$  (unless otherwise noted)

PARAMETER		TEST CONDITIONS		MIN	TYP	MAX	UNIT
<b>TEMPERATURE TO DIGITAL CONVERTER</b>							
Temperature accuracy	TMP117	-20 °C to 50 °C	8 averages 1-Hz conversion cycle Thermal Pad unsoldered (DRV Package) I <sup>2</sup> C Input voltages: $V_{IL} \leq 0.05 * V_+$ , $V_{IH} \geq 0.95 * V_+$	-0.1	±0.05	0.1	°C
		-40 °C to 70 °C		-0.15	±0.05	0.15	
		-40 °C to 100 °C		-0.2	±0.1	0.2	
		-55 °C to 125 °C		-0.25	±0.1	0.25	
		-55 °C to 150 °C		-0.3	±0.1	0.3	
		25 °C to 50 °C		-0.1	±0.05	0.1	
	TMP117M	0 °C to 70 °C		-0.15	±0.05	0.15	
		0 °C to 85 °C		-0.2	±0.1	0.2	
		-40 °C to 100 °C		-0.2	±0.1	0.2	
	TMP117N	-55 °C to 125 °C		-0.25	±0.1	0.25	
		-55 °C to 150 °C		-0.3	±0.1	0.3	
DC power supply sensitivity		One-shot mode, 8 Averages		6			m°C/V
Temperature resolution (LSB)				7.8125			m°C
Repeatability <sup>(1)</sup>		$V_+ = 3.3\text{ V}$ 8 averages 1-Hz conversion cycle		±1			LSB
Long-term stability and drift		1000 hours at 150 °C <sup>(2)</sup>		±0.03			°C
Temperature cycling and hysteresis <sup>(3)</sup>		8 Averages		±2			LSB
Conversion time		One-shot mode		13	15.5	17.5	ms
<b>DIGITAL INPUT/OUTPUT</b>							
Input capacitance				4			pF
$V_{IH}$	Input logic high level	SCL, SDA		0.7 * ( $V_+$ )			V
$V_{IL}$	Input logic low level	SCL, SDA		0.3 * ( $V_+$ )			V
$I_{IN}$	Input leakage current			-0.1		0.1	µA
$V_{OL}$	SDA and ALERT output logic low level	$I_{OL} = -3\text{ mA}$		0		0.4	V
<b>POWER SUPPLY</b>							
$I_{Q\_ACTIV E}$	Quiescent current during active conversion	Active Conversion, serial bus inactive		135	220		µA
$I_Q$	Quiescent current	Duty cycle 1 Hz, averaging mode off, serial bus inactive. $T_A = 25\text{ °C}$		3.5	5		µA
		Duty cycle 1 Hz, 8 averaging mode on, serial bus inactive. $T_A = 25\text{ °C}$		16	22		
		Duty cycle 1 Hz, averaging mode off, serial bus active, SCL frequency = 400 kHz		15			
$I_{SB}$	Standby current <sup>(4)</sup>	Serial bus inactive. SCL, SDA, and ADD0 = $V_+$ . $T_A = 25\text{ °C}$		1.25	3.1		µA
$I_{SD}$	Shutdown current	Serial bus inactive, SCL, SDA, and ADD0 = $V_+$ . $T_A = 25\text{ °C}$		0.15	0.5		µA
		Serial bus inactive, SCL, SDA and ADD0 = $V_+$ , $T_A = 150\text{ °C}$			5		
		Serial bus active, SCL frequency = 400 kHz, ADD0 = $V_+$		17			
$I_{EE}$	EEPROM write quiescent current	ADC conversion off; serial bus inactive		240			µA

Over free-air temperature range and  $V+ = 1.7\text{ V}$  to  $5.5\text{ V}$  for  $T_A = -55\text{ }^\circ\text{C}$  to  $70\text{ }^\circ\text{C}$ , or  $V+ = 1.8\text{ V}$  to  $5.5\text{ V}$  for  $T_A = -55\text{ }^\circ\text{C}$  to  $150\text{ }^\circ\text{C}$  (unless otherwise noted); Typical specifications are at  $T_A = 25\text{ }^\circ\text{C}$  and  $V+ = 3.3\text{ V}$  (unless otherwise noted)

PARAMETER		TEST CONDITIONS	MIN	TYP	MAX	UNIT
$V_{\text{POR}}$	Power-on-reset threshold voltage	Supply rising		1.6		V
	Brownout detect	Supply falling		1.1		V
$t_{\text{RESET}}$	Reset Time	Time required by device to reset		1.5		ms

- (1) Repeatability is the ability to reproduce a reading when the measured temperature is applied consecutively, under the same conditions.
- (2) Long term stability is determined using accelerated operational life testing at a junction temperature of  $150\text{ }^\circ\text{C}$ .
- (3) Hysteresis is defined as the ability to reproduce a temperature reading as the temperature varies from room  $\rightarrow$  hot  $\rightarrow$  room  $\rightarrow$  cold  $\rightarrow$  room. The temperatures used for this test are  $-40\text{ }^\circ\text{C}$ ,  $25\text{ }^\circ\text{C}$ , and  $150\text{ }^\circ\text{C}$ .
- (4) Quiescent current between conversions

## 6.6 Switching Characteristics

Over free-air temperature range and  $V+ = 1.7\text{ V}$  to  $5.5\text{ V}$  for  $T_A = -55\text{ }^\circ\text{C}$  to  $70\text{ }^\circ\text{C}$ , or  $V+ = 1.8\text{ V}$  to  $5.5\text{ V}$  for  $T_A = -55\text{ }^\circ\text{C}$  to  $150\text{ }^\circ\text{C}$  (unless otherwise noted); Typical specifications are at  $T_A = 25\text{ }^\circ\text{C}$  and  $V+ = 3.3\text{ V}$  (unless otherwise noted)

PARAMETER		TEST CONDITIONS	MIN	TYP	MAX	UNIT
<b>EEPROM</b>						
Programming time				7		ms
Number of writes			1,000	50,000		Times
Data retention time			10	100		Years

## 6.7 Two-Wire Interface Timing

Over free-air temperature range and  $V+ = 1.7\text{ V}$  to  $5.5\text{ V}$  for  $T_A = -55\text{ }^\circ\text{C}$  to  $70\text{ }^\circ\text{C}$ , or  $V+ = 1.8\text{ V}$  to  $5.5\text{ V}$  for  $T_A = -55\text{ }^\circ\text{C}$  to  $150\text{ }^\circ\text{C}$  (unless otherwise noted)

		FAST-MODE		UNIT
		MIN	MAX	
$f_{\text{SCL}}$	SCL operating frequency	1	400	KHz
$t_{\text{BUF}}$	Bus free time between STOP and START conditions	1300		ns
$t_{\text{HD,STA}}$	Hold time after repeated START condition. After this period, the first clock is generated <sup>(1)</sup>	600		ns
$t_{\text{SU,STA}}$	Repeated START condition setup time	600		ns
$t_{\text{SU,STO}}$	STOP condition setup time	600		ns
$t_{\text{HD,DAT}}$	Data hold time	0		ns
$t_{\text{VD,DAT}}$	Data valid time <sup>(2)</sup>		0.9	$\mu\text{s}$
$t_{\text{SU,DAT}}$	Data setup time	100		ns
$t_{\text{LOW}}$	SCL clock low period	1300		ns
$t_{\text{HIGH}}$	SCL clock high period	600		ns
$t_{\text{F}} - \text{SDA}$	Data fall time	$20 \times$ $(V+ / 5.5)$	300	ns
$t_{\text{F}}, t_{\text{R}} - \text{SCL}$	Clock fall and rise time		300	ns
$t_{\text{R}}$	Rise time for SCL $\leq 100\text{ kHz}$		1000	ns
	Serial bus timeout (SDA bus released if there is no clock)	20	40	ms

- (1) The maximum  $t_{\text{HD,DAT}}$  could be  $0.9\text{ }\mu\text{s}$  for Fast-Mode, and is less than the maximum  $t_{\text{VD,DAT}}$  by a transition time.
- (2)  $t_{\text{VD,DATA}}$  = time for data signal from SCL "LOW" to SDA output ("HIGH" to "LOW", depending on which is worse).

## 6.8 Timing Diagram

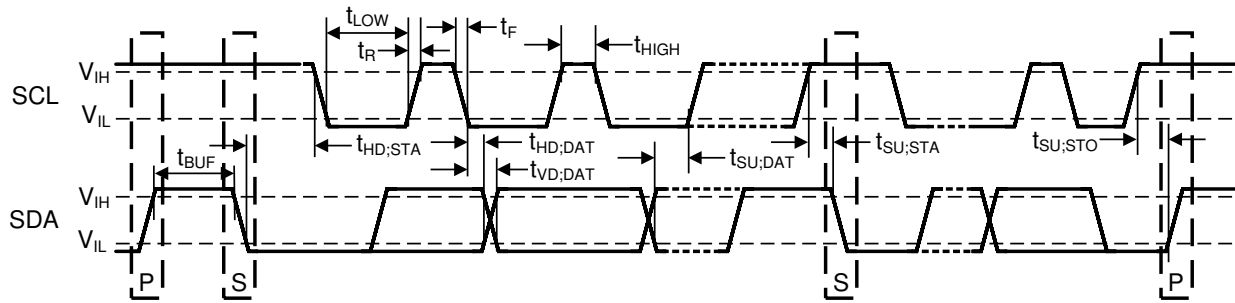


Figure 6-1. Two-Wire Timing Diagram

## 6.9 Typical Characteristics

at  $T_A = 25^\circ\text{C}$ ,  $V+ = 3.3\text{ V}$ , and measurement taken in oil bath (unless otherwise noted)

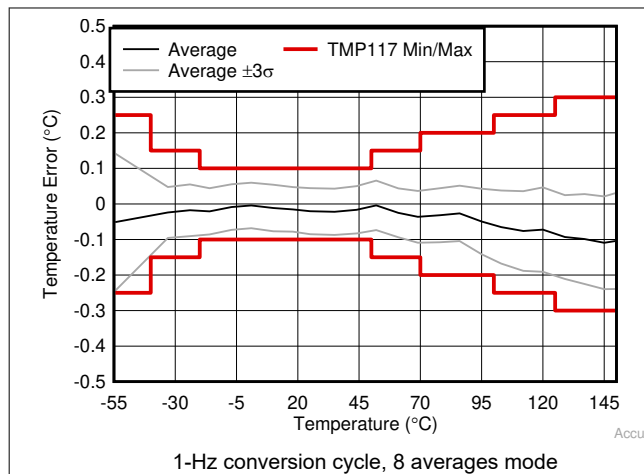


Figure 6-2. DRV Package Temperature Error vs Temperature

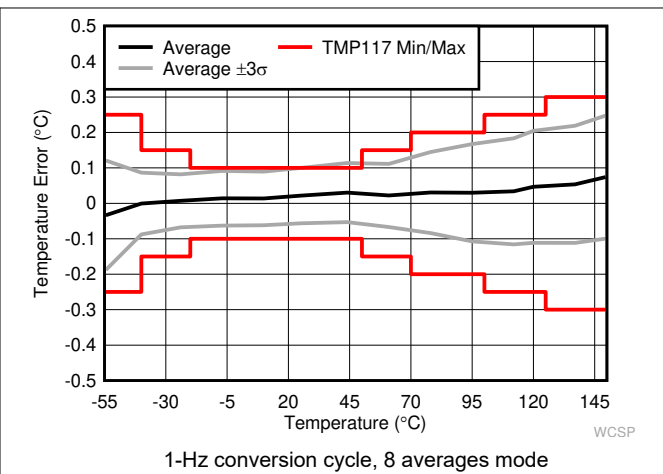


Figure 6-3. YBG Package Temperature Error vs Temperature

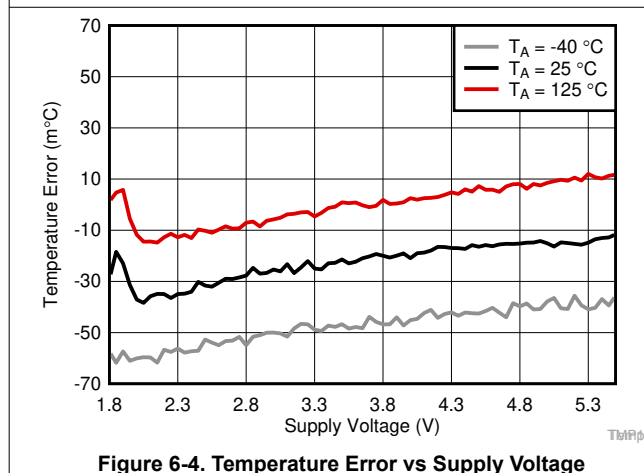


Figure 6-4. Temperature Error vs Supply Voltage

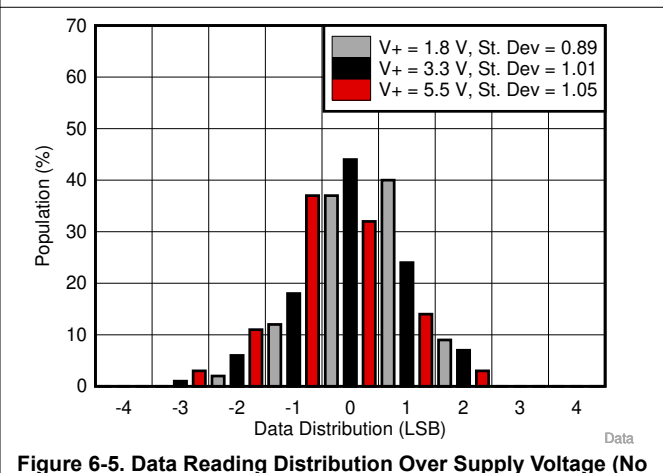
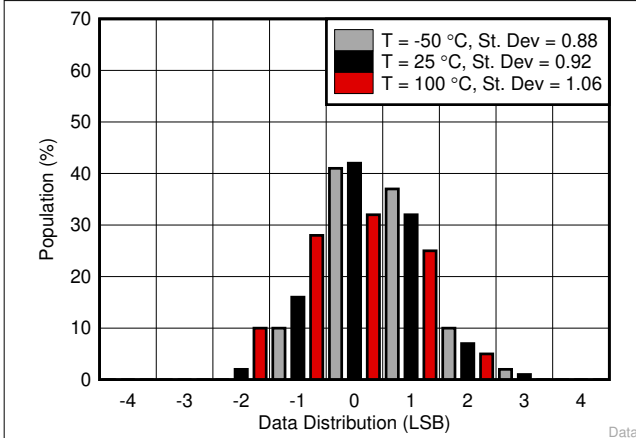


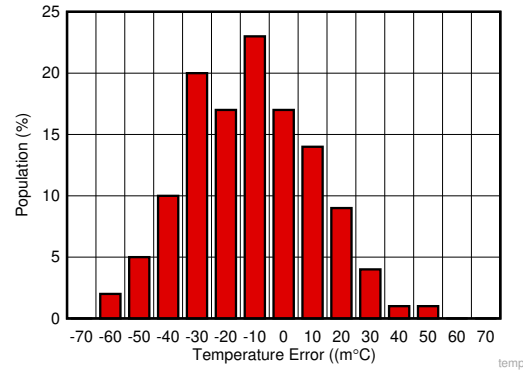
Figure 6-5. Data Reading Distribution Over Supply Voltage (No Averaging)

### 6.9 Typical Characteristics (continued)

at  $T_A = 25^\circ\text{C}$ ,  $V_+ = 3.3\text{ V}$ , and measurement taken in oil bath (unless otherwise noted)

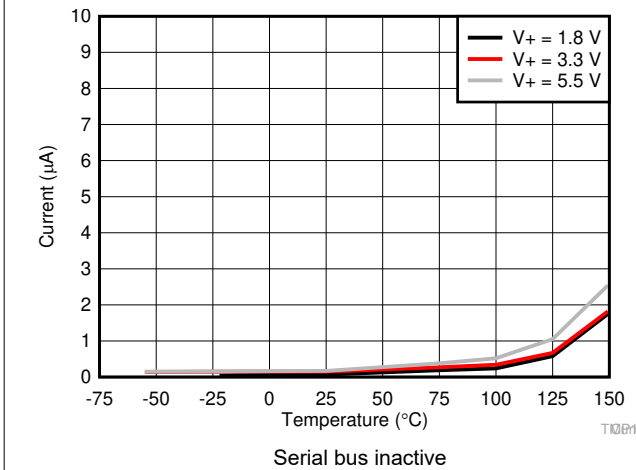


**Figure 6-6. Data Reading Distribution Over Temperature (No Averaging,  $V_+ = 3.3\text{ V}$ )**

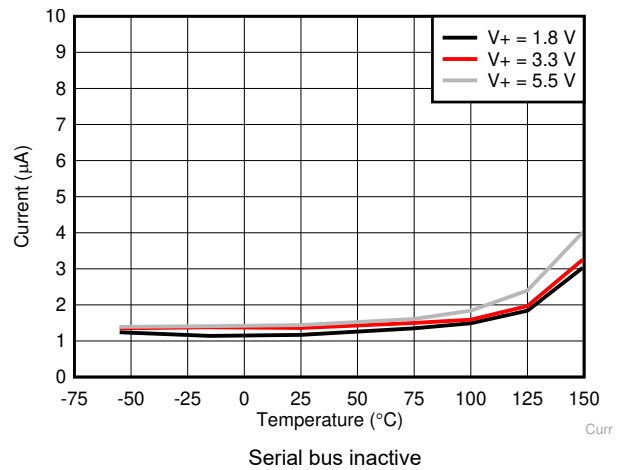


$T_A = 25^\circ\text{C}$ ,  $V_+ = 3.3\text{ V}$ . One-shot mode with averaging = 8.

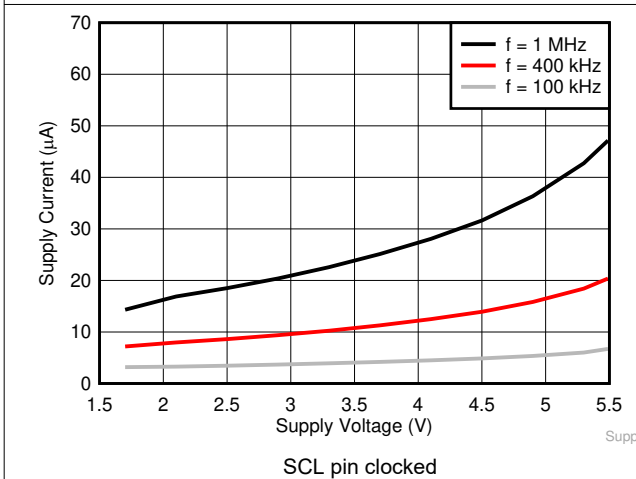
**Figure 6-7. Typical Temperature Distribution Error**



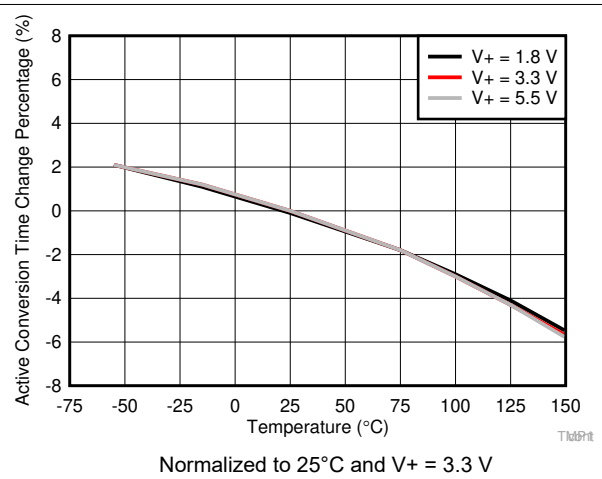
**Figure 6-8. Quiescent Current in Shutdown Mode**



**Figure 6-9. Quiescent Current in Standby Mode**



**Figure 6-10. Quiescent Current in Shutdown Mode**



**Figure 6-11. Active Conversion Time vs Temperature**

### 6.9 Typical Characteristics (continued)

at  $T_A = 25^\circ\text{C}$ ,  $V_+ = 3.3\text{ V}$ , and measurement taken in oil bath (unless otherwise noted)

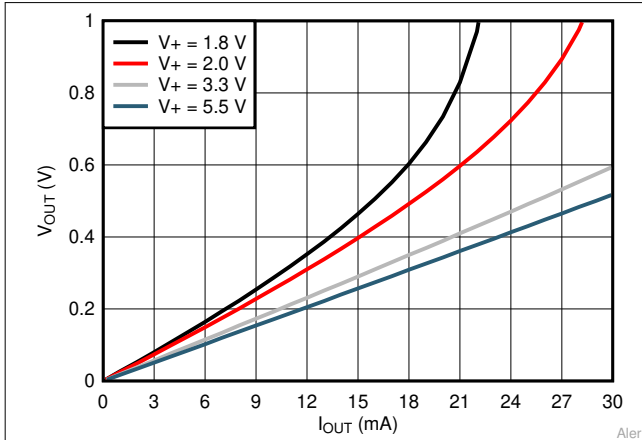


Figure 6-12. ALERT Pin Output Voltage vs Pin Sink Current

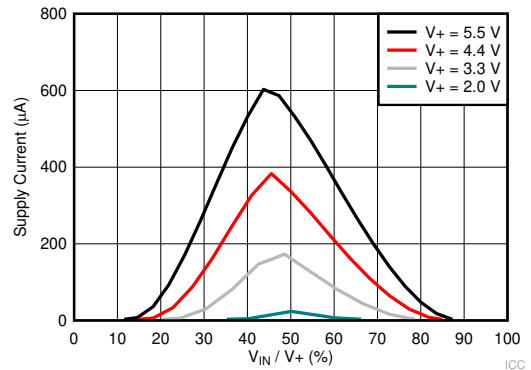


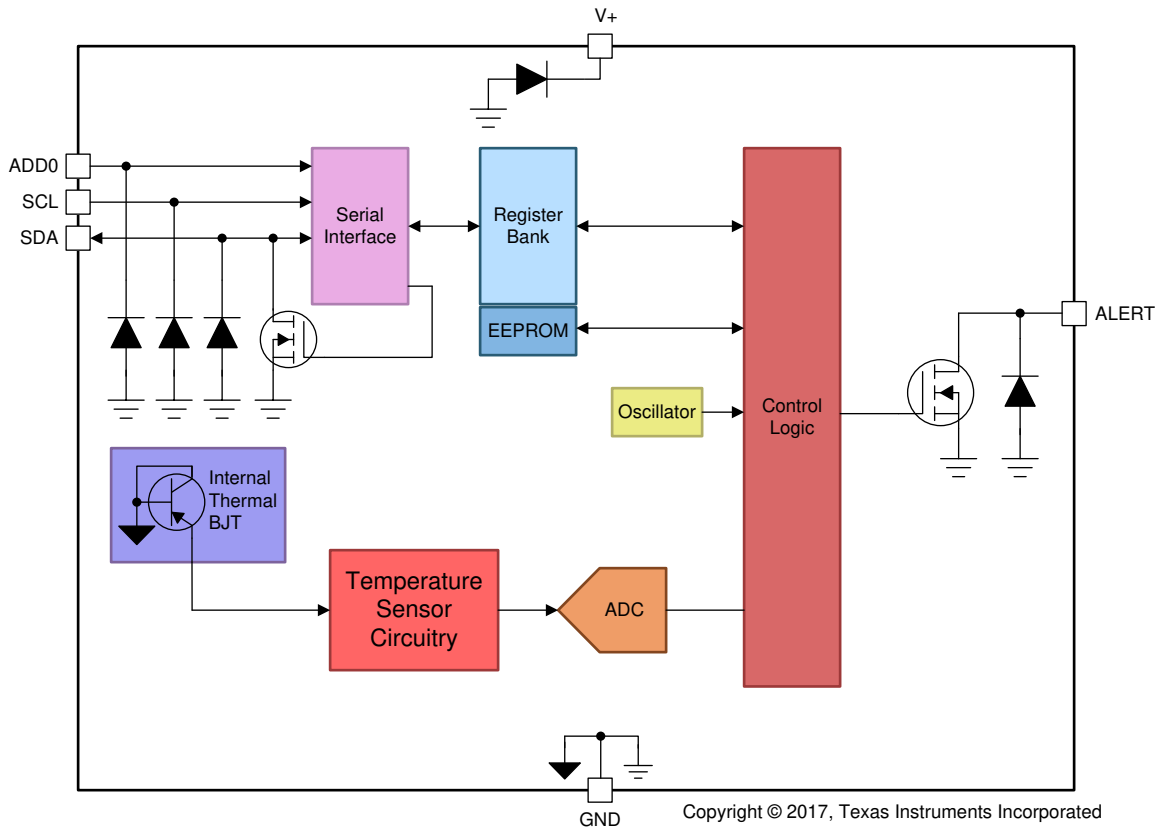
Figure 6-13. Supply Current vs Input Cell Voltage

## 7 Detailed Description

### 7.1 Overview

The TMP117 is a digital output temperature sensor designed for thermal-management and thermal-protection applications. The TMP117 is two-wire, SMBus, and I<sup>2</sup>C interface-compatible. The device is specified over an ambient air operating temperature range of –55 °C to 150 °C. [Figure 7-1](#) shows a block diagram of the TMP117.

### 7.2 Functional Block Diagrams



**Figure 7-1. Internal Block Diagram**

## 7.3 Feature Description

### 7.3.1 Power Up

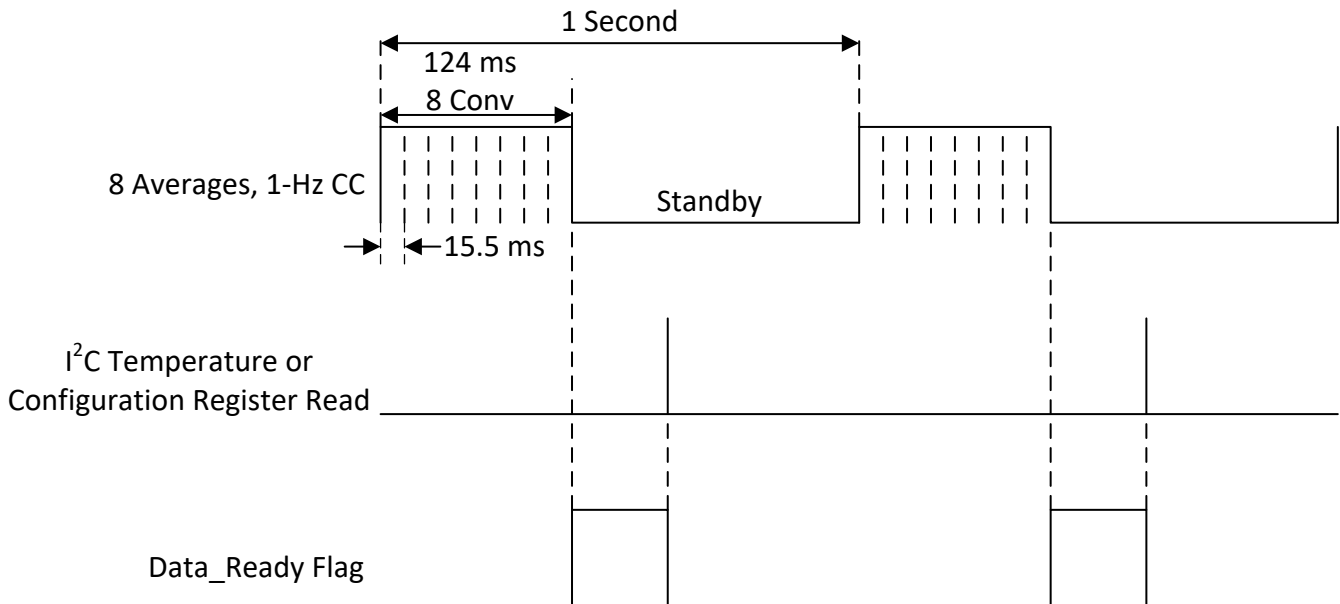
After the supply voltage reaches within the operating range, the device requires 1.5 ms to power up before conversions can begin. The device can be programmed to start up in shutdown mode as well. See the [EEPROM Programming](#) section for more information. The [temperature register](#) reads  $-256\text{ }^{\circ}\text{C}$  before the first conversion.

### 7.3.2 Averaging

Users can configure the device to report the average of multiple temperature conversions with the [AVG\[1:0\]](#) bits to reduce noise in the conversion results. When the TMP117 is configured to perform averaging with AVG set to 01, the device executes the configured number of conversions to eight. The device accumulates those conversion results and reports the average of all the collected results at the end of the process. As shown in the noise histograms of [Figure 6-6](#) and [Figure 6-7](#), the temperature result output has a repeatability of approximately  $\pm 3$  LSBs when there is no averaging and  $\pm 1$  LSB when the device is configured to perform eight averages.

[Figure 7-2](#) shows the total conversion cycle time trade-off when using the averaging mode to achieve this improvement in noise performance. Averaging will increase the average active current consumption due to increasing the active conversion time in a conversion cycle. For example a single active conversion typically takes 15.5 ms, so if the device is configured to report an average of eight conversions, then the active conversion time is 124 ms ( $15.5\text{ ms} \times 8$ ). Use [Equation 1](#) to factor in this increase in active conversion time to accurately calculate the average current consumption of the device. The average current consumption of the device can be decreased by increasing the amount of time the device spends in standby period as compared to active conversion. Under the factory EEPROM settings, the device is configured to report an average of eight conversions with a conversion cycle time of 1 second by default.

Averaging can be used in both the continuous conversion mode and the one-shot mode.



**Figure 7-2. Averaging Timing Diagram**

### 7.3.3 Temperature Result and Limits

At the end of every conversion, the device updates the temperature register with the conversion result. The data in the result register is in two's complement format, has a data width of 16 bits and a resolution of 7.8125 m°C. [Table 7-1](#) shows multiple examples of possible binary data that can be read from the temperature result register and the corresponding hexadecimal and temperature equivalents.

The TMP117 also has alert status flags and alert pin functionality that use the temperature limits stored in the [low limit register](#) and [high limit register](#). The same data format used for the temperature result register is used for data written to the high and low limit registers.

**Table 7-1. 16-Bit Temperature Data Format**

TEMPERATURE (°C)	TEMPERATURE REGISTER VALUE (0.0078125 °C RESOLUTION)	
	BINARY	HEX
-256	1000 0000 0000 0000	8000
-25	1111 0011 1000 0000	F380
-0.1250	1111 1111 1111 0000	FFF0
-0.0078125	1111 1111 1111 1111	FFFF
0	0000 0000 0000 0000	0000
0.0078125	0000 0000 0000 0001	0001
0.1250	0000 0000 0001 0000	0010
1	0000 0000 1000 0000	0080
25	0000 1100 1000 0000	0C80
100	0011 0010 0000 0000	3200
255.9921	0111 1111 1111 1111	7FFF

## 7.4 Device Functional Modes

The TMP117 can be configured to operate in various conversion modes by using the MOD[1:0] bits. These modes provide flexibility to operate the device in the most power efficient way necessary for the intended application.

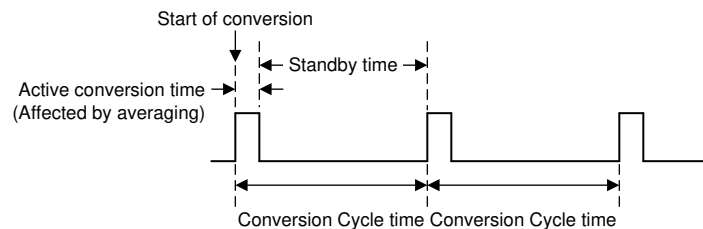
### 7.4.1 Continuous Conversion Mode

When the MOD[1:0] bits are set to 00 or 10 in the [configuration register](#), the device operates in continuous conversion mode. The device continuously performs temperature conversions in this mode, as shown in [Figure 7-3](#), and updates the temperature result register at the end of every active conversion. The user can read the configuration register or the temperature result register to clear the Data\_Ready flag. Therefore, the Data\_Ready flag can be used to determine when the conversion completes so that an external controller can synchronize reading the result register with conversion result updates. The user can set the DR/nAlert\_EN bit in the configuration register to monitor the state of the Data\_Ready flag on the ALERT pin.

Every conversion cycle consists of an active conversion period followed by a standby period. The device typically consumes 135  $\mu\text{A}$  during active conversion and only 1.25  $\mu\text{A}$  during the low-power standby period. [Figure 7-3](#) shows a current consumption profile of a conversion cycle while in continuous current mode. The duration of the active conversion period and standby period can be configured using the CONV[2:0] and AVG[1:0] bits in the [configuration register](#), thereby allowing the average current consumption of the device to be optimized based on the application requirements. Changing the conversion cycle period also affects the temperature result update rate because the temperature result register is updated at the end of every active conversion.

Use [Equation 1](#) to calculate the average current consumption of the device in continuous conversion mode.

$$\frac{(\text{Active Current Consumption} \times \text{Active Conversion Time}) + (\text{Standby Current Consumption} \times \text{Standby Time})}{\text{Conversion Cycle Time}} \quad (1)$$



**Figure 7-3. Conversion Cycle Timing Diagram**

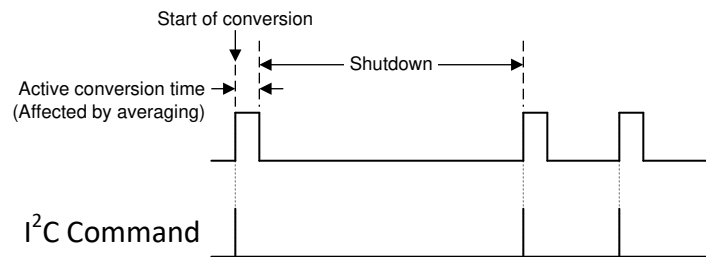
### 7.4.2 Shutdown Mode (SD)

When the MOD[1:0] bits are set to 01 in the [configuration register](#), the device instantly aborts the currently running conversion and enters a low-power shutdown mode. In this mode, the device powers down all active circuitry and can be used in conjunction with the OS mode to perform temperature conversions. Engineers can use the TMP117 for battery-operated systems and other low-power consumption applications because the device typically only consumes 250 nA in SD mode.

### 7.4.3 One-Shot Mode (OS)

When MOD[1:0] bits are set to 11 in the [configuration register](#), the TMP117 will run a temperature conversion referred to as a one-shot conversion. After the device completes a one-shot conversion, the device goes to the low-power shutdown mode. A one-shot conversion cycle, unlike the continuous conversion mode, only consists of the active conversion time and no standby period. Thus, the duration of a one-shot conversion is only affected by the AVG bit settings. The CONV bits do not affect the duration of a one-shot conversion. [Figure 7-4](#) shows a timing diagram for this mode with an AVG setting of 00. At the end of a one-shot conversion, the Data\_Ready and ALERT flag in the configuration register is set. The Data\_Ready flag can be used to determine when the conversion completes. The user can perform an I<sup>2</sup>C read on the configuration register or temperature result register to clear the Data\_Ready flag. The user can also set the DR/nAlert\_EN bit in the configuration register to monitor the state of the Data\_Ready flag on the ALERT pin.

One-shot mode cannot be programmed to a default start-up mode. If the EEPROM is programmed to be in one-shot mode on start-up, it will default to shutdown mode instead.



**Figure 7-4. One-Shot Timing Diagram With AVG[1:0] = 00**

### 7.4.4 Therm and Alert Modes

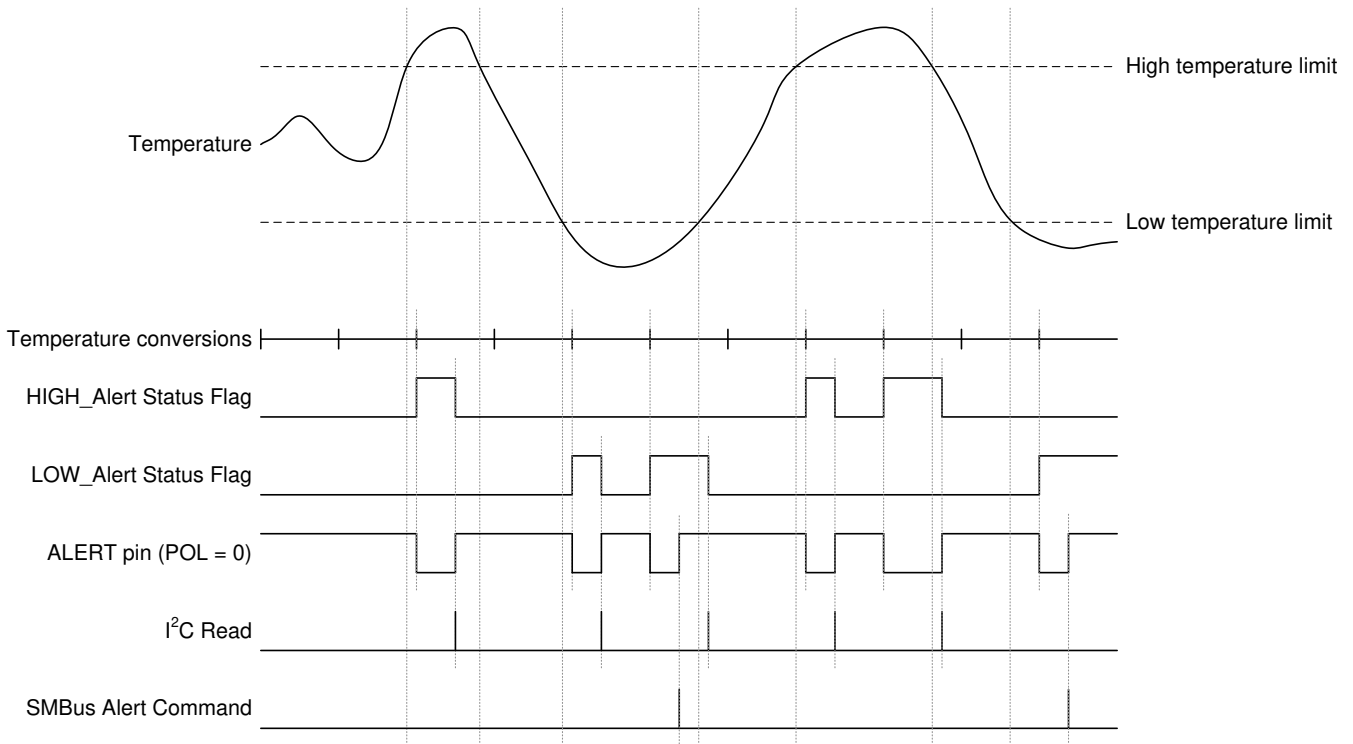
The built-in therm and alert functions of the TMP117 can alert the user if the temperature has crossed a certain temperature limit or if the device is within a certain temperature range. At the end of every conversion, including averaging, the TMP117 compares the converted temperature result to the values stored in the [low limit register](#) and [high limit register](#). The device then either sets or clears the corresponding status flags in the configuration register, as described in this section.

### 7.4.4.1 Alert Mode

When the T/nA bit in the [configuration register](#) is set to 0, the device is in alert mode. In this mode, the device compares the conversion result at the end of every conversion with the values in the [low limit register](#) and [high limit register](#). If the temperature result exceeds the value in the high limit register, the HIGH\_Alert status flag in the configuration register is set. On the other hand, if the temperature result is lower than the value in the low limit register, the LOW\_Alert status flag in the configuration register is set. As shown in [Figure 7-5](#), the user can run an I<sup>2</sup>C read from the configuration register to clear the status flags in alert mode.

When a user configures the device in alert mode, it affects the behavior of the ALERT pin. The device asserts the ALERT pin in this mode when either the HIGH\_Alert or the LOW\_Alert status flag is set, as shown in [Figure 7-5](#). The user can either run an I<sup>2</sup>C read of the configuration register (which also clears the status flags) or run an SMBus alert response command (see the [SMBus Alert Function](#) section) to deassert the ALERT pin. The polarity of the ALERT pin can be changed by using the POL bit setting in the configuration register.

This mode effectively makes the device behave like a window limit detector. Thus this mode can be used in applications where detecting if the temperature goes outside of the specified range is necessary.



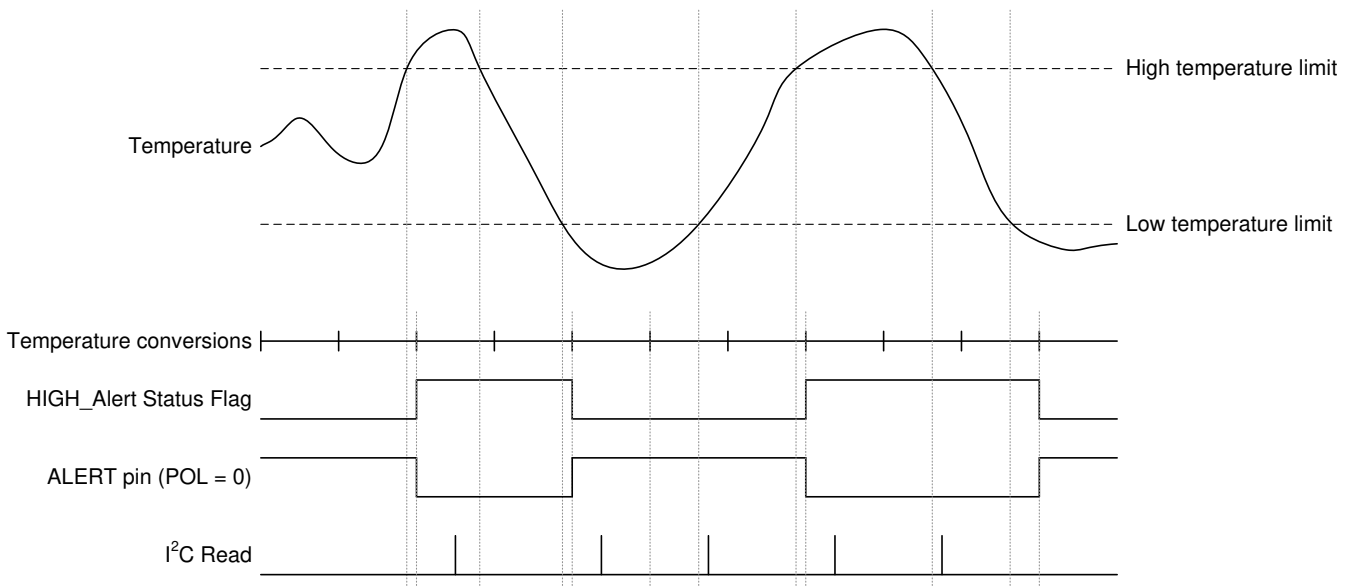
**Figure 7-5. Alert Mode Timing Diagram**

### 7.4.4.2 Therm Mode

When the T/nA bit in the [configuration register](#) is set to 1 the device is in therm mode. In this mode, the device compares the conversion result at the end of every conversion with the values in the [low limit register](#) and [high limit register](#) and sets the HIGH\_Alert status flag in the configuration register if the temperature exceeds the value in the high limit register. When set, the device clears the HIGH\_Alert status flag if the conversion result goes below the value in the low limit register. Thus, the difference between the high and low limits effectively acts like a hysteresis. In this mode, the LOW\_Alert status flag is disabled and always reads 0. Unlike the alert mode, I<sup>2</sup>C reads of the configuration register do not affect the status bits. The HIGH\_Alert status flag is only set or cleared at the end of conversions based on the value of the temperature result compared to the high and low limits.

As in alert mode, configuring the device in therm mode also affects the behavior of the ALERT pin. In this mode, the device asserts the ALERT pin if the HIGH\_Alert status flag is set and deasserts the ALERT pin when the HIGH\_Alert status flag is cleared. In therm mode, the ALERT pin cannot be cleared by performing an I<sup>2</sup>C read of the configuration register or by performing an SMBus alert response command. As in alert mode, the polarity of the active state of the ALERT pin can be changed if the user adjusts the POL bit setting in the configuration register.

Thus, this mode effectively makes the device behave like a high-limit threshold detector. This mode can be used in applications where detecting if the temperature has gone above a desired threshold is necessary. [Figure 7-6](#) shows a timing diagram of this mode.



**Figure 7-6. Therm Mode Timing Diagram**

## 7.5 Programming

### 7.5.1 EEPROM Programming

#### 7.5.1.1 EEPROM Overview

The device has a user-programmable EEPROM that can be used for two purposes:

- Storing power-on reset (POR) values of the high limit register, low limit register, conversion cycle time, averaging mode, conversion mode (continuous or shutdown mode), alert function mode (alert or therm mode), and alert polarity
- Storing four 16-bit locations for general-purpose use. See the [EEPROM\[4:1\] registers](#) for more information.

On reset, the device goes through a POR sequence that loads the values programmed in the EEPROM into the respective register map locations. This process takes approximately 1.5 ms. When the power-up sequence is complete, the device starts operating in accordance to the configuration parameters that are loaded from the EEPROM. Any I<sup>2</sup>C writes performed during this initial POR period to the limit registers or the configuration register are ignored. I<sup>2</sup>C read transactions can still be performed with the device during the power-up period. While the POR sequence is being executed, the EEPROM\_Busy status flag in the [EEPROM unlock register](#) is set.

During production, the EEPROM in the TMP117 is programmed with reset values as shown in [Table 7-3](#). The [Programming the EEPROM](#) section describes how to change these values. A unique ID is also programmed in the general-purpose EEPROM locations during production. This unique ID is used to support NIST traceability. The TMP117 units are 100% tested on a production setup that is NIST traceable and verified with equipment that is calibrated to ISO/IEC 17025 accredited standards. Only reprogram the general-purpose EEPROM[4:1] locations if NIST traceability is not desired.

#### 7.5.1.2 Programming the EEPROM

To prevent accidental programming, the EEPROM is locked by default. When locked, any I<sup>2</sup>C writes to the register map locations are performed only on the volatile registers and not on the EEPROM.

[Figure 7-7](#) shows a flow chart describing the EEPROM programming sequence. To program the EEPROM, first unlock the EEPROM by setting the EUN bit in the [EEPROM unlock register](#). After the EEPROM is unlocked, any subsequent I<sup>2</sup>C writes to the register map locations program a corresponding non-volatile memory location in the EEPROM. Programming a single location typically takes 7 ms to complete and consumes 230  $\mu$ A. Do not perform any I<sup>2</sup>C writes until programming is complete. During programming, the EEPROM\_busy flag is set. Read this flag to monitor if the programming is complete. After programming the desired data, issue a general-call reset command to trigger a software reset. The programmed data from the EEPROM are then loaded to the corresponding register map locations as part of the reset sequence. This command also clears the EUN bit and automatically locks the EEPROM to prevent any further accidental programming. Avoid using the device to perform temperature conversions when the EEPROM is unlocked.

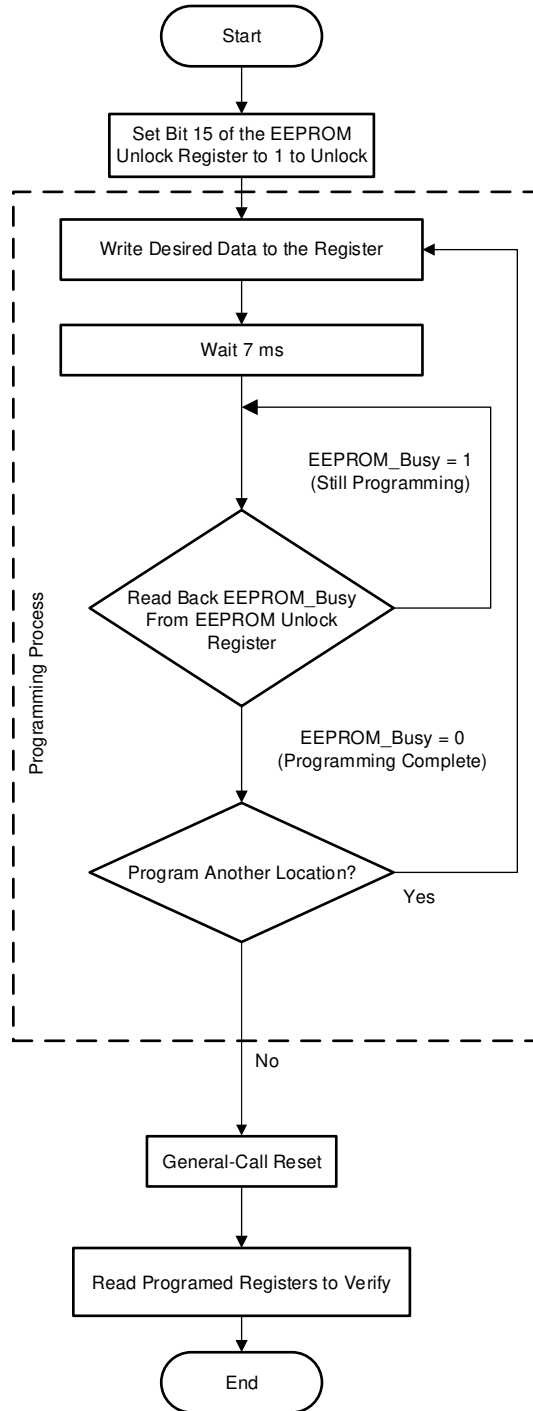
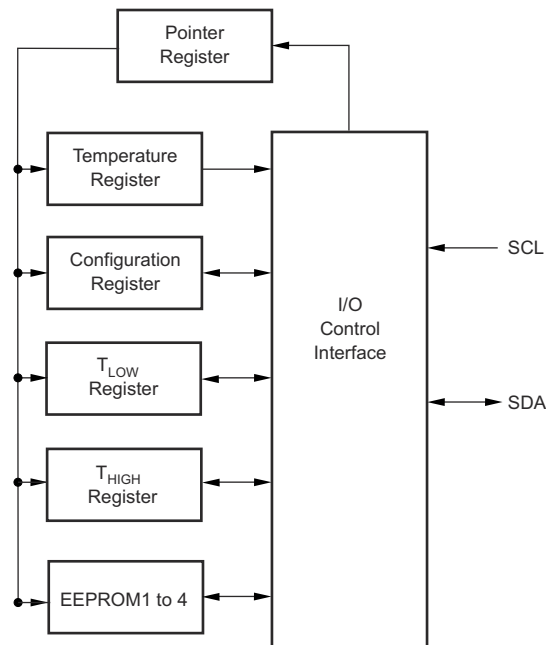


Figure 7-7. EEPROM Programming Sequence

## 7.5.2 Pointer Register

Figure 7-8 shows the internal register structure of the TMP117. The 8-bit pointer register of the device is used to address a given data register. The reset value is 00.



**Figure 7-8. Internal Register Structures**

## 7.5.3 I<sup>2</sup>C and SMBus Interface

### 7.5.3.1 Serial Interface

The TMP117 operates as a slave device only on the two-wire, SMBus and I<sup>2</sup>C interface-compatible bus. Connections to the bus are made through the open-drain I/O lines and the SDA and SCL pins. The SDA and SCL pins feature integrated spike-suppression filters and Schmitt triggers to minimize the effects of input spikes and bus noise. The device supports the transmission protocol for fast (1 kHz to 400 kHz) mode. Register bytes are sent with the most significant byte first, followed by the least significant byte.

#### 7.5.3.1.1 Bus Overview

The device that initiates the transfer is called a *master*, and the devices controlled by the master are *slaves*. The bus must be controlled by a master device that generates the serial clock (SCL), controls the bus access, and generates the START and STOP conditions.

To address a specific device, a START condition is initiated, indicated by pulling the data line (SDA) from a high-to-low-logic level when the SCL pin is high. All slaves on the bus shift in the slave address byte on the rising edge of the clock, and the last bit indicates whether a read or write operation is intended. During the ninth clock pulse, the addressed slave generates an acknowledge and pulls the SDA pin low to respond to the master.

A data transfer is then initiated and sent over eight clock pulses followed by an acknowledge bit. During the data transfer, the SDA pin must remain stable when the SCL pin is high because any change in the SDA pin when the SCL pin is high is interpreted as a START or STOP signal.

When all data are transferred, the master generates a repeated START condition or a STOP condition.

- TMP117 will ignore any I<sup>2</sup>C traffic until a START condition is observed
- TMP117 I<sup>2</sup>C state machine resets every time it sees a STOP condition
- TMP117 must not be connected to an I<sup>2</sup>C bus during active communication.

### 7.5.3.1.2 Serial Bus Address

To communicate with the TMP117, the master must first address slave devices through an address byte. The address byte has seven address bits and a read-write (R/W) bit that indicates the intent of executing a read or write operation.

The TMP117 features an address pin to allow up to four devices to be addressed on a single bus. [Table 7-2](#) describes the pin logic levels used to properly connect up to four devices. x represents the read-write (R/  $\bar{W}$ ) bit.

**Table 7-2. Address Pin and Slave Addresses**

DEVICE TWO-WIRE ADDRESS	ADD0 PIN CONNECTION
1001000x	Ground
1001001x	V+
1001010x	SDA
1001011x	SCL

### 7.5.3.1.3 Writing and Reading Operation

The user can write a register address to the pointer register to access a particular register on the TMP117. The value for the pointer register is the first byte transferred after the slave address byte with the R/  $\bar{W}$  bit low. Every write operation to the TMP117 requires a value for the pointer register.

When reading from the TMP117, the last value stored in the pointer register by a write operation is used to determine which register is read during a read operation. To change the register pointer for a read operation, a new value must be written to the pointer register. The user can issue an address byte with the R/  $\bar{W}$  bit low, followed by the pointer register byte to write a new value for the pointer register. No additional data is required. The master can then generate a START condition and send the slave address byte with the R/  $\bar{W}$  bit high to initiate the read command. See [Figure 7-10](#) for details of this sequence. If repeated reads from the same register are desired, it is not necessary to send the pointer register bytes continuously because the TMP117 retains the pointer register value until the value is changed by the next write operation.

Register bytes are sent with the most significant byte first, followed by the least significant byte.

### 7.5.3.1.4 Slave Mode Operations

The TMP117 can operate as a slave receiver or slave transmitter. As a slave device, the TMP117 never drives the SCL line.

#### 7.5.3.1.4.1 Slave Receiver Mode

The first byte transmitted by the master is the slave address with the R/  $\bar{W}$  bit low. The TMP117 then acknowledges reception of a valid address. The next byte transmitted by the master is the pointer register. The TMP117 then acknowledges reception of the pointer register byte. The next byte(s) are written to the register addressed by the pointer register. The TMP117 acknowledges reception of each data byte. The master can terminate data transfer by generating a START or STOP condition.

#### 7.5.3.1.4.2 Slave Transmitter Mode

The first byte transmitted by the master is the slave address with the R/  $\bar{W}$  bit high. The slave acknowledges reception of a valid slave address. The next byte is transmitted by the slave and is the most significant byte of the register indicated by the pointer register. The master acknowledges reception of the data byte. The next byte transmitted by the slave is the least significant byte. The master acknowledges reception of the data byte. The master can terminate data transfer by generating a *not-acknowledge* on reception of any data byte or by generating a START or STOP condition.

### 7.5.3.1.5 SMBus Alert Function

The TMP117 supports the SMBus alert function. When the ALERT pin is connected to an SMBus alert signal and a master senses that an alert condition is present, the master can send out an SMBus ALERT command (0001 1001) to the bus. If the ALERT pin is active, the device acknowledges the SMBus ALERT command and responds by returning the slave address on the SDA line. The eighth bit (LSB) of the slave address byte indicates if the alert condition is caused by the temperature exceeding  $T_{(HIGH)}$  or falling below  $T_{(LOW)}$ . The LSB is

high if the temperature is greater than  $T_{(HIGH)}$ , or low if the temperature is less than  $T_{(LOW)}$ . See [Figure 7-11](#) for details of this sequence.

If multiple devices on the bus respond to the SMBus ALERT command, arbitration during the slave address portion of the SMBus ALERT command determines which device clears the alert status of that device. The device with the lowest two-wire address wins the arbitration. If the TMP117 wins the arbitration, the TMP117 ALERT pin becomes inactive at the completion of the SMBus ALERT command. If the TMP117 loses the arbitration, the TMP117 ALERT pin remains active.

#### 7.5.3.1.6 General-Call Reset Function

The TMP117 responds to a two-wire, general-call address (0000 000) if the eighth bit is 0. The device acknowledges the general-call address and responds to commands in the second byte. If the second byte is 0000 0110, the TMP117 internal registers are reset to power-up values.

#### 7.5.3.1.7 Timeout Function

The TMP117 resets the serial interface if the SCL line is held low by the master or the SDA line is held low by the TMP117 for 35 ms (typical) between a START and STOP condition. The TMP117 releases the SDA line if the SCL pin is pulled low and waits for a START condition from the host controller. To avoid activating the timeout function, maintain a communication speed of at least 1 kHz for the SCL operating frequency.

#### 7.5.3.1.8 Timing Diagrams

The TMP117 is two-wire, SMBus and I<sup>2</sup>C interface-compatible. [Figure 7-9](#) to [Figure 7-12](#) show the various operations with the TMP117. Bus definitions are:

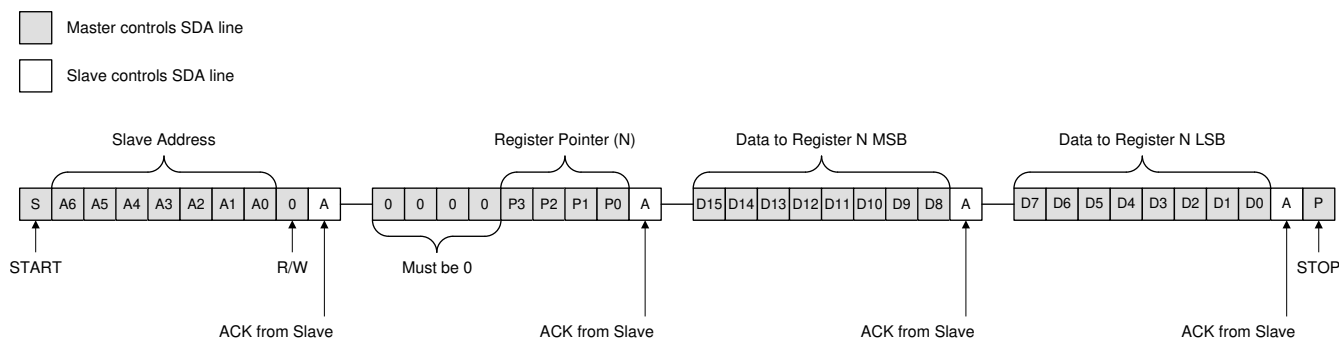
**Bus Idle:** Both SDA and SCL lines remain high.

**Start Data Transfer:** A change in the state of the SDA line from high to low when the SCL line is high defines a START condition. Each data transfer is initiated with a START condition.

**Stop Data Transfer:** A change in the state of the SDA line from low to high when the SCL line is high defines a STOP condition. Each data transfer is terminated with a repeated START or STOP condition.

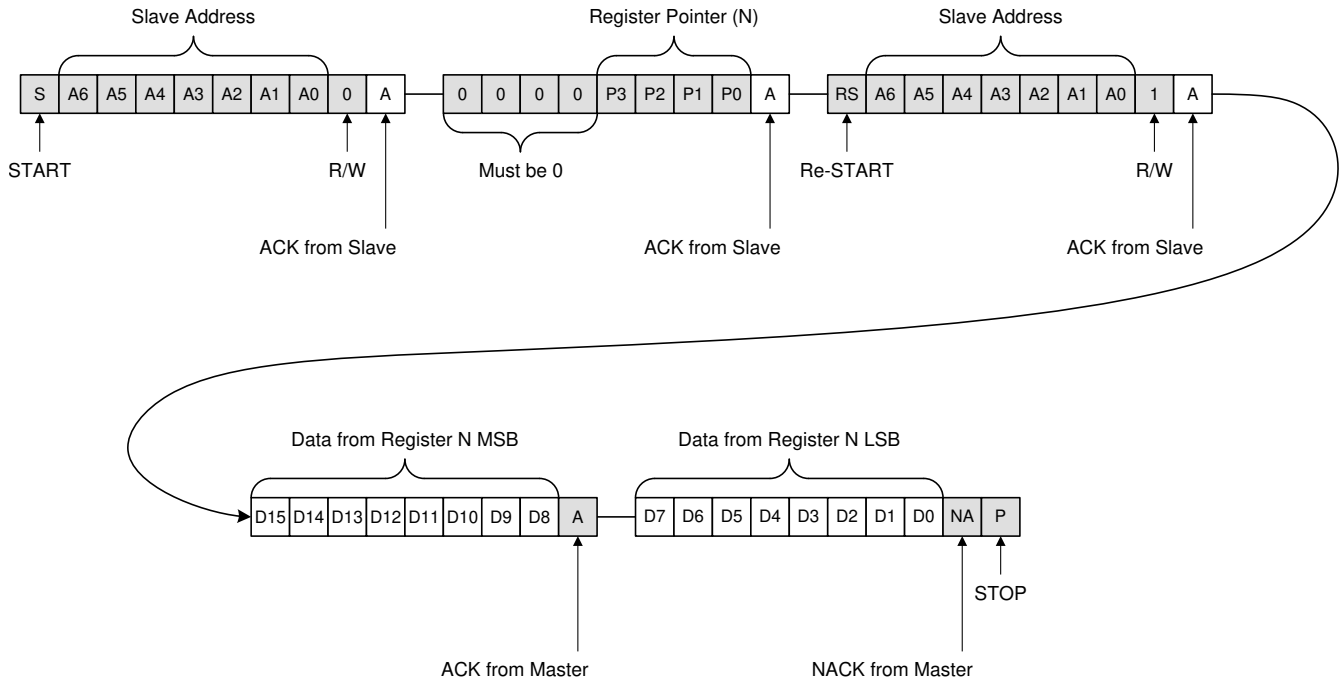
**Data Transfer:** The number of data bytes transferred between a START and a STOP condition is not limited and is determined by the master device.

**Acknowledge:** Each receiving device, when addressed, is obliged to generate an acknowledge bit. A device that acknowledges must pull down the SDA line during the acknowledge clock pulse in such a way that the SDA line is stable low during the high period of the acknowledge clock pulse. The user must take setup and hold times into account. On a master receive, the termination of the data transfer can be signaled by the master generating a *not-acknowledge* (1) on the last byte transmitted by the slave.



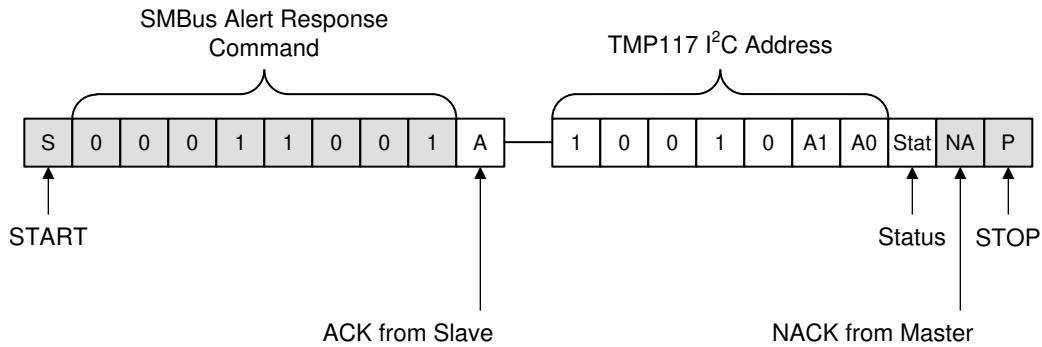
**Figure 7-9. Write Word Command Timing Diagram**

- Master controls SDA line
- Slave controls SDA line

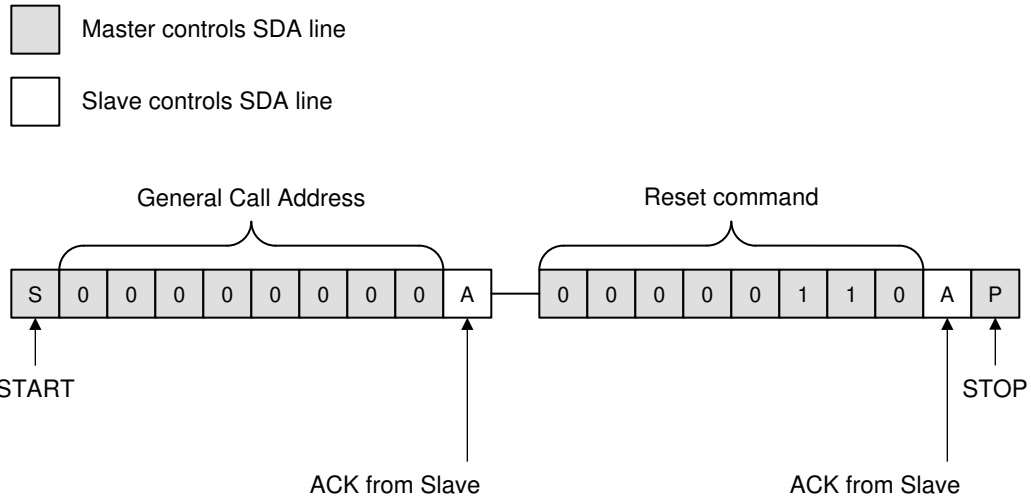


**Figure 7-10. Read Word Command Timing Diagram**

- Master controls SDA line
- Slave controls SDA line



**Figure 7-11. SMBus ALERT Timing Diagram**



**Figure 7-12. General-Call Reset Command Timing Diagram**

## 7.6 Register Map

**Table 7-3. TMP117 Register Map**

ADDRESS	TYPE	RESET	ACRONYM	REGISTER NAME	SECTION
00h	R	8000h	Temp_Result	Temperature result register	<a href="#">Go</a>
01h	R/W	0220h <sup>(1)</sup>	Configuration	Configuration register	<a href="#">Go</a>
02h	R/W	6000h <sup>(1)</sup>	THigh_Limit	Temperature high limit register	<a href="#">Go</a>
03h	R/W	8000h <sup>(1)</sup>	TLow_Limit	Temperature low limit register	<a href="#">Go</a>
04h	R/W	0000h	EEPROM_UL	EEPROM unlock register	<a href="#">Go</a>
05h	R/W	xxxxh <sup>(1)</sup>	EEPROM1	EEPROM1 register	<a href="#">Go</a>
06h	R/W	xxxxh <sup>(1)</sup>	EEPROM2	EEPROM2 register	<a href="#">Go</a>
07h	R/W	0000h <sup>(1)</sup>	Temp_Offset	Temperature offset register	<a href="#">Go</a>
08h	R/W	xxxxh <sup>(1)</sup>	EEPROM3	EEPROM3 register	<a href="#">Go</a>
0Fh	R	0117h	Device_ID	Device ID register	<a href="#">Go</a>

- (1) This value is stored in Electrically-Erasable, Programmable Read-Only Memory (EEPROM) during device manufacturing. The device reset value can be changed by writing the relevant code in the EEPROM cells (see the [EEPROM Overview](#) section).

**Table 7-4. TMP117 Access Type Codes**

Access Type	Code	Description
Read Type		
R	R	Read
RC	R C	Read to Clear
Write Type		
W	W	Write
Reset or Default Value		
-n		Value after reset or the default value

## 7.6.1 Register Descriptions

### 7.6.2 Temperature Register (address = 00h) [default reset = 8000h]

This register is a 16-bit, read-only register that stores the output of the most recent conversion. One LSB equals 7.8125 m°C. Data are represented in binary two's complement format. Following a reset, the temperature register reads –256 °C until the first conversion, including averaging, is complete. See the [Power Up](#) section for more information.

Return to [Register Map](#).

**Figure 7-13. Temperature Register**

15	14	13	12	11	10	9	8
T15	T14	T13	T12	T11	T10	T9	T8
R-1	R-0	R-0	R-0	R-0	R-0	R-0	R-0
7	6	5	4	3	2	1	0
T7	T6	T5	T4	T3	T2	T1	T0
R-0	R-0	R-0	R-0	R-0	R-0	R-0	R-0

**Table 7-5. Temperature Register Field Descriptions**

BIT	FIELD	TYPE	RESET	DESCRIPTION
15:0	T[15:0]	R	8000h	16-bit, read-only register that stores the most recent temperature conversion results.

### 7.6.3 Configuration Register (address = 01h) [factory default reset = 0220h]

Return to [Register Map](#).

**Figure 7-14. Configuration Register**

15	14	13	12	11	10	9	8
HIGH_Alert	LOW_Alert	Data_Ready	EEPROM_Busy	MOD1 <sup>(2)</sup>	MOD0 <sup>(1)</sup>	CONV2 <sup>(1)</sup>	CONV1 <sup>(1)</sup>
R-0	R-0	R-0	R-0	R/W-0	R/W-0	R/W-1	R/W-0
7	6	5	4	3	2	1	0
CONV0 <sup>(1)</sup>	AVG1 <sup>(1)</sup>	AVG0 <sup>(1)</sup>	T/nA <sup>(1)</sup>	POL <sup>(1)</sup>	DR/Alert <sup>(1)</sup>	Soft_Reset	—
R/W-0	R/W-0	R/W-1	R/W-0	R/W-0	R/W-0	R-0	R-0

**Table 7-6. Configuration Register Field Descriptions**

BIT	FIELD	TYPE	RESET	DESCRIPTION
15	HIGH_Alert	R	0	High Alert flag: 1: Set when the conversion result is higher than the high limit 0: Cleared on read of configuration register Therm mode: 1: Set when the conversion result is higher than the therm limit 0: Cleared when the conversion result is lower than the hysteresis
14	LOW_Alert	R	0	Low Alert flag: 1: Set when the conversion result is lower than the low limit 0: Cleared when the configuration register is read Therm mode: Always set to 0
13	Data_Ready	R	0	Data ready flag. This flag indicates that the conversion is complete and the temperature register can be read. Every time the temperature register or configuration register is read, this bit is cleared. This bit is set at the end of the conversion when the temperature register is updated. Data ready can be monitored on the ALERT pin by setting bit 2 of the configuration register.
12	EEPROM_Busy	R	0	EEPROM busy flag. The value of the flag indicates that the EEPROM is busy during programming or power-up.
11:10	MOD[1:0]	R/W	0	Set conversion mode. 00: Continuous conversion (CC) 01: Shutdown (SD) 10: Continuous conversion (CC), Same as 00 (reads back = 00) 11: One-shot conversion (OS)
9:7	CONV[2:0]	R/W	100	Conversion cycle bit. See <a href="#">Table 7-7</a> for the standby time between conversions.
6:5	AVG[1:0]	R/W	01	Conversion averaging modes. Determines the number of conversion results that are collected and averaged before updating the temperature register. The average is an accumulated average and not a running average. 00: No averaging 01: 8 Averaged conversions 10: 32 averaged conversions 11: 64 averaged conversions
4	T/nA	R/W	0	Therm/alert mode select. 1: Therm mode 0: Alert mode
3	POL	R/W	0	ALERT pin polarity bit. 1: Active high 0: Active low
2	DR/Alert	R/W	0	ALERT pin select bit. 1: ALERT pin reflects the status of the data ready flag 0: ALERT pin reflects the status of the alert flags

**Table 7-6. Configuration Register Field Descriptions (continued)**

BIT	FIELD	TYPE	RESET	DESCRIPTION
1	Soft_Reset	R/W	0	Software reset bit. When set to 1 it triggers software reset with a duration of 2 ms This bit will always read back 0
0	—	R	0	Not used

- (1) These bits can be stored in EEPROM. The factory setting for this register is 0220.
- (2) The MOD1 bit cannot be stored in EEPROM. The device can only be programmed to start up in shutdown mode or continuous conversion mode.

**Table 7-7. Conversion Cycle Time in CC Mode**

CONV[2:0]	AVG[1:0] = 00	AVG[1:0] = 01	AVG[1:0] = 10	AVG[1:0] = 11
000	15.5 ms	125 ms	500 ms	1 s
001	125 ms	125 ms	500 ms	1 s
010	250 ms	250 ms	500 ms	1 s
011	500 ms	500 ms	500 ms	1 s
100	1 s	1 s	1 s	1 s
101	4 s	4 s	4 s	4 s
110	8 s	8 s	8 s	8 s
111	16 s	16 s	16 s	16 s

If the time to complete the conversions needed for a given averaging setting is higher than the conversion setting cycle time, there will be no stand by time in the conversion cycle.

### 7.6.4 High Limit Register (address = 02h) [Factory default reset = 6000h]

This register is a 16-bit, read/write register that stores the high limit for comparison with the temperature result. One LSB equals 7.8125 m°C. The range of the register is ±256 °C. Negative numbers are represented in binary two's complement format. Following power-up or a general-call reset, the high-limit register is loaded with the stored value from the EEPROM. The factory default reset value is 6000h.

Return to [Register Map](#).

**Figure 7-15. High Limit Register**

15		14		13		12		11		10		9		8	
H15		H14		H13		H12		H11		H10		H9		H8	
R/W-0		R/W-1		R/W-1		R/W-0		R/W-0		R/W-0		R/W-0		R/W-0	
7		6		5		4		3		2		1		0	
H7		H6		H5		H4		H3		H2		H1		H0	
R/W-0		R/W-0		R/W-0		R/W-0		R/W-0		R/W-0		R/W-0		R/W-0	

**Table 7-8. High Limit Register Field Descriptions**

BIT	FIELD	TYPE	RESET	DESCRIPTION
15:0	H[15:0]	R/W	6000h	16-bit, read/write register that stores the high limit for comparison with the temperature result.

### 7.6.5 Low Limit Register (address = 03h) [Factory default reset = 8000h]

This register is configured as a 16-bit, read/write register that stores the low limit for comparison with the temperature result. One LSB equals 7.8125 m°C. The range of the register is ±256 °C. Negative numbers are represented in binary two's complement format. The data format is the same as the temperature register. Following power-up or reset, the low-limit register is loaded with the stored value from the EEPROM. The factory default reset value is 8000h.

Return to [Register Map](#).

**Figure 7-16. Low Limit Register**

15		14		13		12		11		10		9		8	
L15		L14		L13		L12		L11		L10		L9		L8	
R/W-1		R/W-0		R/W-0		R/W-0		R/W-0		R/W-0		R/W-0		R/W-0	
7		6		5		4		3		2		1		0	
L7		L6		L5		L4		L3		L2		L1		L0	
R/W-0		R/W-0		R/W-0		R/W-0		R/W-0		R/W-0		R/W-0		R/W-0	

**Table 7-9. Low Limit Register Field Descriptions**

BIT	FIELD	TYPE	RESET	DESCRIPTION
15:0	L[15:0]	R/W	8000h	16-bit, read/write register that stores the low limit for comparison with the temperature result.

### 7.6.6 EEPROM Unlock Register (address = 04h) [reset = 0000h]

Return to [Register Map](#).

**Figure 7-17. EEPROM Unlock Register**

15	14	13	12	11	10	9	8
EUN	EEPROM_Busy	—	—	—	—	—	—
R/W-0	R-0	R-0	R-0	R-0	R-0	R-0	R-0
7	6	5	4	3	2	1	0
—	—	—	—	—	—	—	—
R-0	R-0	R-0	R-0	R-0	R-0	R-0	R-0

**Table 7-10. EEPROM Unlock Register Field Descriptions**

BIT	FIELD	TYPE	RESET	DESCRIPTION
15	EUN	R/W	0	EEPROM unlock. 0: EEPROM is locked for programming: writes to all EEPROM addresses (such as configuration, limits, and EEPROM locations 1-4) are written to registers in digital logic and are not programmed in the EEPROM 1: EEPROM unlocked for programming: any writes to programmable registers program the respective location in the EEPROM
14	EEPROM_Busy	R	0	EEPROM busy. This flag is the mirror of the EEPROM busy flag (bit 12) in the configuration register. 0: Indicates that the EEPROM is ready, which means that the EEPROM has finished the last transaction and is ready to accept new commands 1: Indicates that the EEPROM is busy, which means that the EEPROM is currently completing a programming operation or performing power-up on reset load
13:0	—	R	0	Not used

### 7.6.7 EEPROM1 Register (address = 05h) [reset = XXXXh]

The EEPROM1 register is a 16-bit register that be used as a scratch pad by the customer to store general-purpose data. This register has a corresponding EEPROM location. Writes to this address when the EEPROM is locked write data into the register and not to the EEPROM. Writes to this register when the EEPROM is unlocked causes the corresponding EEPROM location to be programmed. See the [Programming the EEPROM](#) section for more information. EEPROM[4:1] are preprogrammed during manufacturing with the unique ID that can be overwritten. To support NIST traceability do not delete or reprogram the EEPROM[1] register.

Return to [Register Map](#).

**Figure 7-18. EEPROM1 Register**

15	14	13	12	11	10	9	8
D15	D14	D13	D12	D11	D10	D9	D8
R/W-x	R/W-x	R/W-x	R/W-x	R/W-x	R/W-x	R/W-x	R/W-x
7	6	5	4	3	2	1	0
D7	D6	D5	D4	D3	D2	D1	D0
R/W-x	R/W-x	R/W-x	R/W-x	R/W-x	R/W-x	R/W-x	R/W-x

**Table 7-11. EEPROM1 Register Field Descriptions**

BIT	FIELD	TYPE	RESET	DESCRIPTION
15:0	D[15:0]	R/W	xxxxh	This 16-bit register can be used as a scratch pad. To support NIST traceability do not delete or re-program this register.

### 7.6.8 EEPROM2 Register (address = 06h) [reset = 0000h]

This register function the same as the EEPROM1 register.

Return to [Register Map](#).

**Figure 7-19. EEPROM2 Register**

15		14		13		12		11		10		9		8	
D15	D14	D13	D12	D11	D10	D9	D8	D7	D6	D5	D4	D3	D2	D1	D0
R/W-x		R/W-x		R/W-x		R/W-x		R/W-x		R/W-x		R/W-x		R/W-x	
7		6		5		4		3		2		1		0	
D7	D6	D5	D4	D3	D2	D1	D0	D7	D6	D5	D4	D3	D2	D1	D0
R/W-x		R/W-x		R/W-x		R/W-x		R/W-x		R/W-x		R/W-x		R/W-x	

**Table 7-12. EEPROM2 Register Field Descriptions**

BIT	FIELD	TYPE	RESET	DESCRIPTION
15:0	D[15:0]	R/W	xxxxh	This 16-bit register can be used as a scratch pad.

### 7.6.9 Temperature Offset Register (address = 07h) [reset = 0000h]

This 16-bit register is to be used as a user-defined temperature offset register during system calibration. The offset will be added to the temperature result after linearization. It has a same resolution of 7.8125 m°C and same range of ±256 °C as the temperature result register. The data format is the same as the temperature register. If the added result is out of boundary, then the temperature result will show as the maximum or minimum value.

Return to [Register Map](#).

**Figure 7-20. Temperature Offset Register**

15		14		13		12		11		10		9		8	
D15	D14	D13	D12	D11	D10	D9	D8	D7	D6	D5	D4	D3	D2	D1	D0
R/W-0		R/W-0		R/W-0		R/W-0		R/W-0		R/W-0		R/W-0		R/W-0	
7		6		5		4		3		2		1		0	
D7	D6	D5	D4	D3	D2	D1	D0	D7	D6	D5	D4	D3	D2	D1	D0
R/W-0		R/W-0		R/W-0		R/W-0		R/W-0		R/W-0		R/W-0		R/W-0	

**Table 7-13. Temperature Offset Register Field Descriptions**

BIT	FIELD	TYPE	RESET	DESCRIPTION
15:0	D[15:0]	R/W	0	Temperature offset data from system calibration.

### 7.6.10 EEPROM3 Register (address = 08h) [reset = xxxh]

This register function is the same as the EEPROM1 register. To support NIST traceability, do not delete or reprogram the EEPROM[1] register.

Return to [Register Map](#).

**Figure 7-21. EEPROM3 Register**

15	14	13	12	11	10	9	8
D15	D14	D13	D12	D11	D10	D9	D8
R/W-x	R/W-x	R/W-x	R/W-x	R/W-x	R/W-x	R/W-x	R/W-x
7	6	5	4	3	2	1	0
D7	D6	D5	D4	D3	D2	D1	D0
R/W-x	R/W-x	R/W-x	R/W-x	R/W-x	R/W-x	R/W-x	R/W-x

**Table 7-14. EEPROM3 Register Field Descriptions**

BIT	FIELD	TYPE	RESET	DESCRIPTION
15:0	D[15:0]	R/W	xxxh	This 16-bit register is used as a scratch pad. To support NIST traceability, do not delete or re-program this register.

### 7.6.11 Device ID Register (address = 0Fh) [reset = 0117h]

This read-only register indicates the device ID.

Return to [Register Map](#).

**Figure 7-22. Device ID Register**

15	14	13	12	11	10	9	8
Rev3	Rev2	Rev1	Rev0	DID11	DID10	DID9	DID8
R-x	R-x	R-x	R-x	R-0	R-0	R-0	R-1
7	6	5	4	3	2	1	0
DID7	DID6	DID5	DID4	DID3	DID2	DID1	DID0
R-0	R-0	R-0	R-1	R-0	R-1	R-1	R-1

**Table 7-15. Device ID Register Field Descriptions**

BIT	FIELD	TYPE	RESET	DESCRIPTION
15:12	Rev[3:0]	R	0h	Indicates the revision number.
11:0	DID[11:0]	R	117h	Indicates the device ID.

## 8 Application and Implementation

### Note

Information in the following applications sections is not part of the TI component specification, and TI does not warrant its accuracy or completeness. TI's customers are responsible for determining suitability of components for their purposes, as well as validating and testing their design implementation to confirm system functionality.

### 8.1 Application Information

The TMP117 is used to measure the temperature of the board location where the device is mounted. The programmable address options allow up to four locations on the board to be monitored on a single serial bus. For more information, refer to the related [Considerations for Measuring Ambient Air Temperature](#) (SNOA966), [Replacing resistance temperature detectors with the TMP116 temp sensor](#) (SNOA969), and [Temperature sensors: PCB guidelines for surface mount devices](#) (SNOA967) application reports on ti.com.

### 8.2 Typical Application

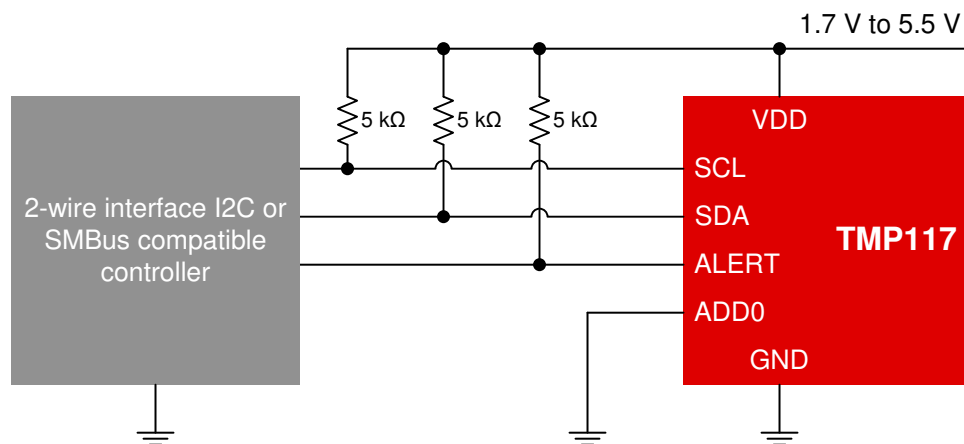


Figure 8-1. Typical Connections

#### 8.2.1 Design Requirements

The TMP117 operates only as a slave device and communicates with the host through the I<sup>2</sup>C-compatible serial interface. SCL is the input pin, SDA is a bidirectional pin, and ALERT is the output. The TMP117 requires a pullup resistor on the SDA, and ALERT pins. The recommended value for the pullup resistors is 5 kΩ. In some applications, the pullup resistor can be lower or higher than 5 kΩ. A 0.1-μF bypass capacitor is recommended to be connected between V+ and GND. An SCL pullup resistor is required if the system microprocessor SCL pin is open-drain. Use a ceramic capacitor type with a temperature rating that matches the operating range of the application, and place the capacitor as close as possible to the V+ pin of the TMP117. The ADD0 pin can be connected directly to GND, V+, SDA and SCL for address selection of four possible unique slave ID addresses. [Table 7-1](#) explains the addressing scheme. The ALERT output pin can be connected to a microcontroller interrupt that triggers an event that occurred when the temperature limit exceeds the programmable value in registers 02h and 03h. The ALERT pin can be left floating or connected to ground when not in use.

## 8.2.2 Detailed Design Procedure

### 8.2.2.1 Noise and Averaging

The device temperature sampling distribution (with averaging disabled) covers an area of approximately six neighboring codes. The noise area of the six codes remains the same at full supply and full temperature range with a standard deviation of approximately 1 LSB. The device provides an averaging tool for 1, 8, 32, or 64 conversions. As shown in [Figure 6-7](#), the 8-sample averaging reduces the internal noise distribution to a theoretical minimum of 2 LSB. This averaging means that if the system temperature slowly changes and the supply voltage is stable, then the 8-sample averaging can be enough to neutralize the device noise and provide stable temperature readings. However, if the system environment is noisy (such as when measuring air flow temperatures, power supply fluctuations, intensive communication on a serial bus, and so forth), then higher averaging numbers are recommended to be used.

### 8.2.2.2 Self-Heating Effect (SHE)

During ADC conversion, some power is dissipated that heats the device despite the small power consumption of the TMP117. Consider the self-heating effect (SHE) for certain precise measurements. [Figure 8-2](#) shows the device SHE in still air at 25 °C after the supply is switched on. The device package is soldered to the 11-mm × 20-mm × 1.1-mm size coupon board. The board is placed horizontally, with the device on top. The TMP117 is in continuous conversion mode with 64 sampling averaging and zero conversion cycle time. There is no digital bus activity aside from reading temperature data one time each second. As shown in [Figure 8-2](#), the SHE stabilization time in still air is greater when the device dissipates more power.

The SHE drift is strongly proportional to the device dissipated power. The SHE drift is also proportional to the device temperature because the consumption current with the same supply voltage increases with temperature. [Figure 8-3](#) shows the SHE drifts versus temperature and dissipated power at 25 °C for the same coupon board and the same conditions described previously.

To estimate the SHE for similar size boards, calculate the device consumption power for 25 °C and use the corresponding power line shown in [Figure 8-3](#). For example, in CC mode without DC at a 3.3-V supply at 25 °C, the device dissipates 410 μWt. So self-heating in still air is approximately 40 m°C for the described condition and rises to 52 m°C at 150 °C.

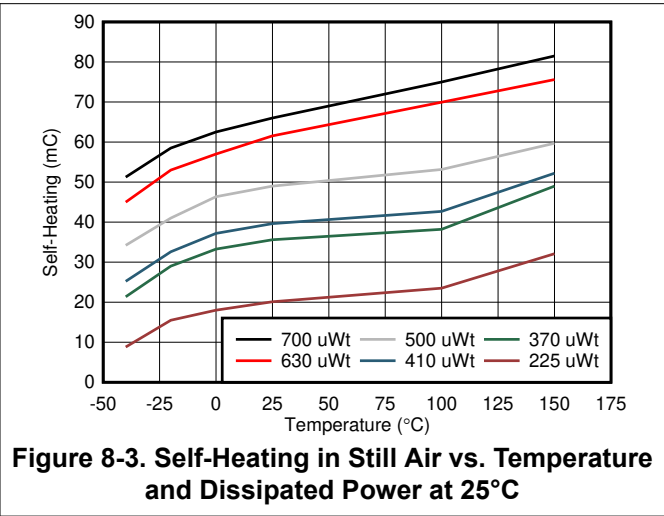
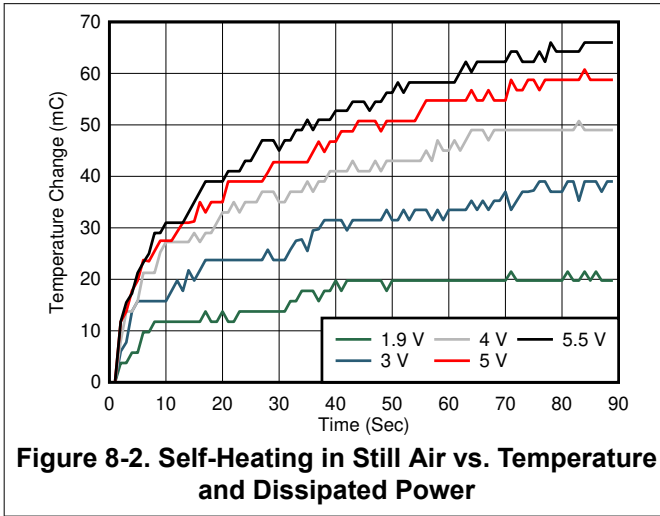
The following methods can reduce the SHE:

- System calibration removes not only the self-heating error and power-supply rejection ratio (PSRR) effect but also compensates the temperature shift caused by the thermal resistance between the device and the measured object.
- If practical, use the device one-shot mode. If continuous conversion is needed, use the conversion cycle mode with significant standby time. For example, in most cases an 8-sample averaging (125 ms) with a 1-second conversion cycle provides enough time for the device to cool down to the environment temperature and removes the SHE.
- Use the minimal acceptable power supply voltage.
- Use a printed-circuit board (PCB) layout that provides minimal thermal resistance to the device.
- Avoid using small-value pullup resistors on the SDA and ALERT pins. Instead, use pullup resistors larger than 2 kΩ.
- Ensure that the SCL and SDA signal levels remain below 10% or above 90% of the device supply voltage.
- Avoid heavy bypass traffic on the data line. Communication to other devices on the same data line increases the supply current even if the device is in SD mode.
- Use the highest available communication speed.

### 8.2.2.3 Synchronized Temperature Measurements

When four temperature measurements are needed in four different places simultaneously, triggering a reset is recommended. In this method, four devices are programmed with control registers set to CC mode with a conversion cycle time of 16 s. All four devices are connected to same two-wire bus with four different bus addresses. The bus general-call reset command is issued by the master. This command triggers all devices to reset (which takes approximately 1.5 ms) and triggers a simultaneous temperature sampling according to configuration registers setting. The master has 16 seconds to read data from the devices.

### 8.2.3 Application Curves



## 9 Power Supply Recommendations

The TMP117 operates on a power-supply range from 1.7 V to 5.5 V. A power-supply bypass capacitor is required, which must be placed as close to the supply and ground pins of the device as possible. A recommended value for this supply bypass capacitor is 100 nF. Applications with noisy or high-impedance power supplies may require additional decoupling capacitors to reject power-supply noise.

The package thermal pad is not connected to the device ground and should be left unsoldered for best measurement accuracy. If the thermal pad is soldered, it must be left floating or grounded.

## 10 Layout

### 10.1 Layout Guidelines

---

#### Note

To achieve a high precision temperature reading for a rigid PCB, do not solder down the thermal pad. For a flexible PCB, the user can solder the thermal pad to increase board level reliability. If thermal pad is soldered it should be connected to the ground or left floating.

---

For more information on board layout, refer to the related [Precise temperature measurements with TMP116 and TMP117](#) (SNOA986) and [Wearable temperature-sensing layout considerations optimized for thermal response](#) (SNIA021) application reports on ti.com.

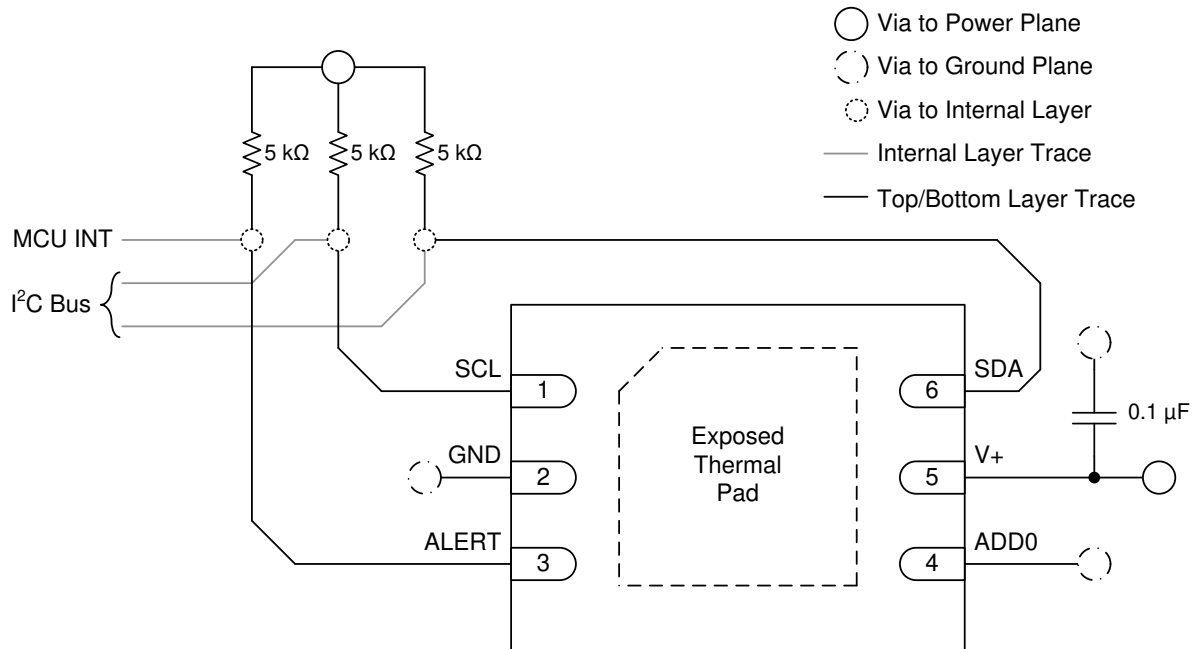
Place the power-supply bypass capacitor as close as possible to the supply and ground pins. The recommended value of this bypass capacitor is 0.1  $\mu\text{F}$ . In some cases, the pullup resistor can be the heat source, therefore, maintain some distance between the resistor and the device.

Mount the TMP117 on the PCB pad to provide the minimum thermal resistance to the measured object surface or to the surrounding air. The recommended PCB layout minimizes the device self-heating effect, reduces the time delay as temperature changes, and minimizes the temperature offset between the device and the object.

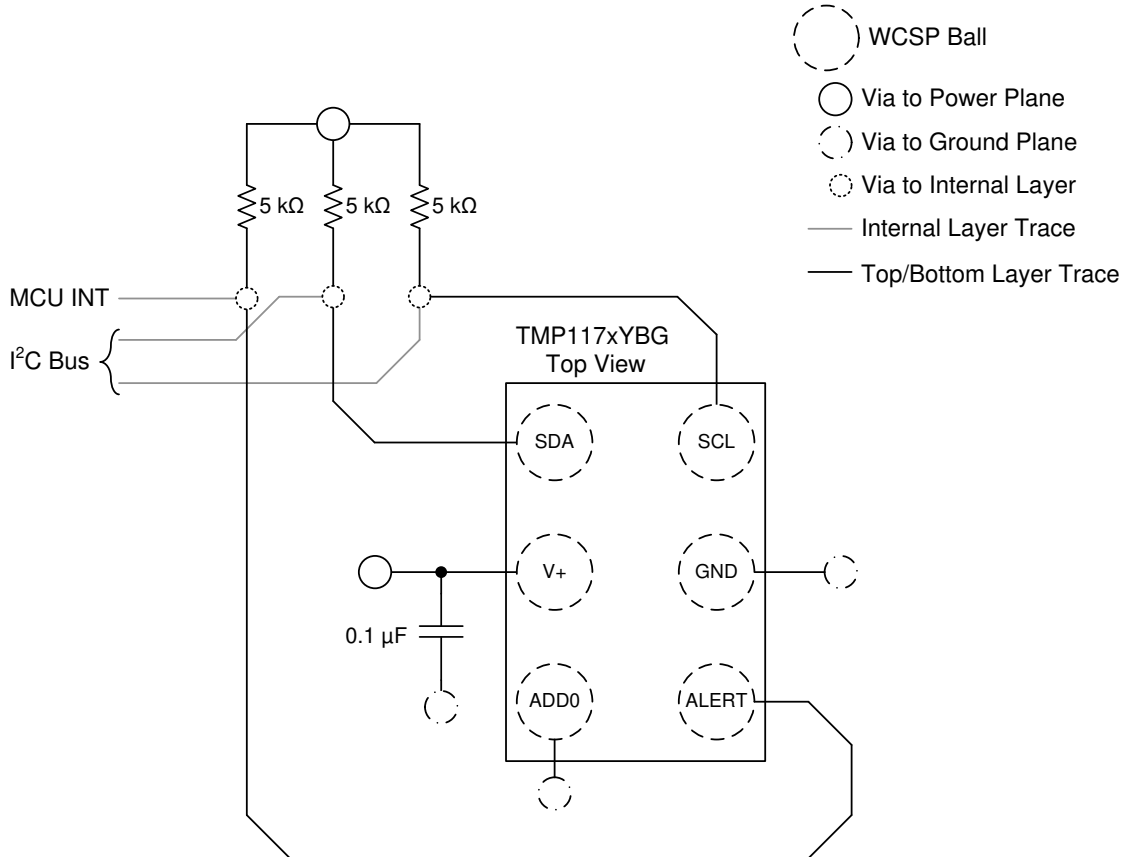
1. Soldering the TMP117 thermal pad to the PCB minimizes the thermal resistance to the PCB, reduces the response time as temperature changes and minimizes the temperature offset between the device and measured object. Simultaneously the soldering of the thermal pad will, however, introduce mechanical stress that can be a source of additional measurement error. For cases when system calibration is not planned, TI recommends not soldering the thermal pad to the PCB. Due to the small thermal mass of the device, not soldering the thermal pad will have a minimal impact on the described characteristics. Manual device soldering to the PCB creates additional mechanical stress on the package, therefore to prevent precision degradation a standard PCB reflow oven process is highly recommended.
2. If the device is used to measure solid surface temperature:
  - Use PCB with minimal thickness.
  - Prevent PCB bending which can create a mechanical stress to package.
  - Cover bottom of the PCB with copper plane.
  - Remove bottom solder mask and cover exposed copper with gold layer if possible.
  - Use thermal conductive paste between PCB and object surface.
  - If PCB has unused internal layers, extend these layers under the sensor.
  - Minimize amount of copper wires on top of the board.
  - To minimize temperature “leakage” to surrounding air locate sensor in place with minimal air movement. Horizontal surfaces are preferable.
  - To minimize temperature offset due to “leakage” to surrounding air cover sensor with thermo isolating foam, tape or at least cover with a stain.
3. If the device is used to measure moving air temperature:
  - Because moving air temperature usually has a lot of fluctuations the PCB increased thermal mass reduces measurement noise.
  - Design PCB soldering pads bigger than usual, especially package corner pads.
  - Use a PCB with thicker copper layers if possible.
  - Cover both side of unused board space with copper layer.
  - Place PCB vertically along air flow.
4. If the device is used to measure still air temperature:
  - Miniaturize the board to reduce thermal mass. Smaller thermal mass results in faster thermal response.
  - Place two copper planes of equal size to the top and bottom of the exposed pad.
  - Remove the top solder mask.
  - To prevent oxidation, cover any exposed copper with solder paste.
  - Thermal isolation is required to avoid thermal coupling from heat source components through the PCB.
  - Avoid running the copper plane underneath the temperature sensor.

- Maximize the air gap between the sensor and the surrounding copper areas (anti-etch), especially when close to the heat source.
- Create a PCB cutout between sensor and other circuits. Leave a narrow channel away from heat source components as a routing bridge into the island.
- If the heat source is top side, avoid running traces on top; instead, route all signals on the bottom side.
- Place the board vertically to improve air flow and to reduce dust collection.

## 10.2 Layout Examples



**Figure 10-1. DRV Layout Recommendation**



**Figure 10-2. YBG Layout Recommendation**

## 11 Device and Documentation Support

### 11.1 Documentation Support

#### 11.1.1 Related Documentation

For related documentation see the following:

- [TMPx75 temperature sensor with I<sup>2</sup>C and SMBus interface in industry standard LM75 form factor and pinout](#) (SBOS288)
- [TMP275 ±0.5°C temperature sensor with I2C and SMBus interface in industry standard LM75 form factor and pinout](#) (SBOS363)
- [Design Considerations for Measuring Ambient Air Temperature](#) (SNOA966)
- [Replacing resistance temperature detectors with the TMP116 temp sensor](#) (SNOA969)
- [Temperature sensors: PCB guidelines for surface mount devices](#) (SNOA967)
- [Precise temperature measurements with TMP116 and TMP117](#) (SNOA986)
- [Wearable temperature-sensing layout considerations optimized for thermal response](#) (SNIA021)

#### 11.2 Receiving Notification of Documentation Updates

To receive notification of documentation updates, navigate to the device product folder on [ti.com](http://ti.com). Click on *Subscribe to updates* to register and receive a weekly digest of any product information that has changed. For change details, review the revision history included in any revised document.

#### 11.3 Support Resources

[TI E2E™ support forums](#) are an engineer's go-to source for fast, verified answers and design help — straight from the experts. Search existing answers or ask your own question to get the quick design help you need.

Linked content is provided "AS IS" by the respective contributors. They do not constitute TI specifications and do not necessarily reflect TI's views; see TI's [Terms of Use](#).

#### 11.4 Trademarks

SMBus™ is a trademark of Intel Corporation.

TI E2E™ is a trademark of Texas Instruments.

All trademarks are the property of their respective owners.

#### 11.5 Electrostatic Discharge Caution



This integrated circuit can be damaged by ESD. Texas Instruments recommends that all integrated circuits be handled with appropriate precautions. Failure to observe proper handling and installation procedures can cause damage.

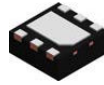
ESD damage can range from subtle performance degradation to complete device failure. Precision integrated circuits may be more susceptible to damage because very small parametric changes could cause the device not to meet its published specifications.

#### 11.6 Glossary

[TI Glossary](#) This glossary lists and explains terms, acronyms, and definitions.

## 12 Mechanical, Packaging, and Orderable Information

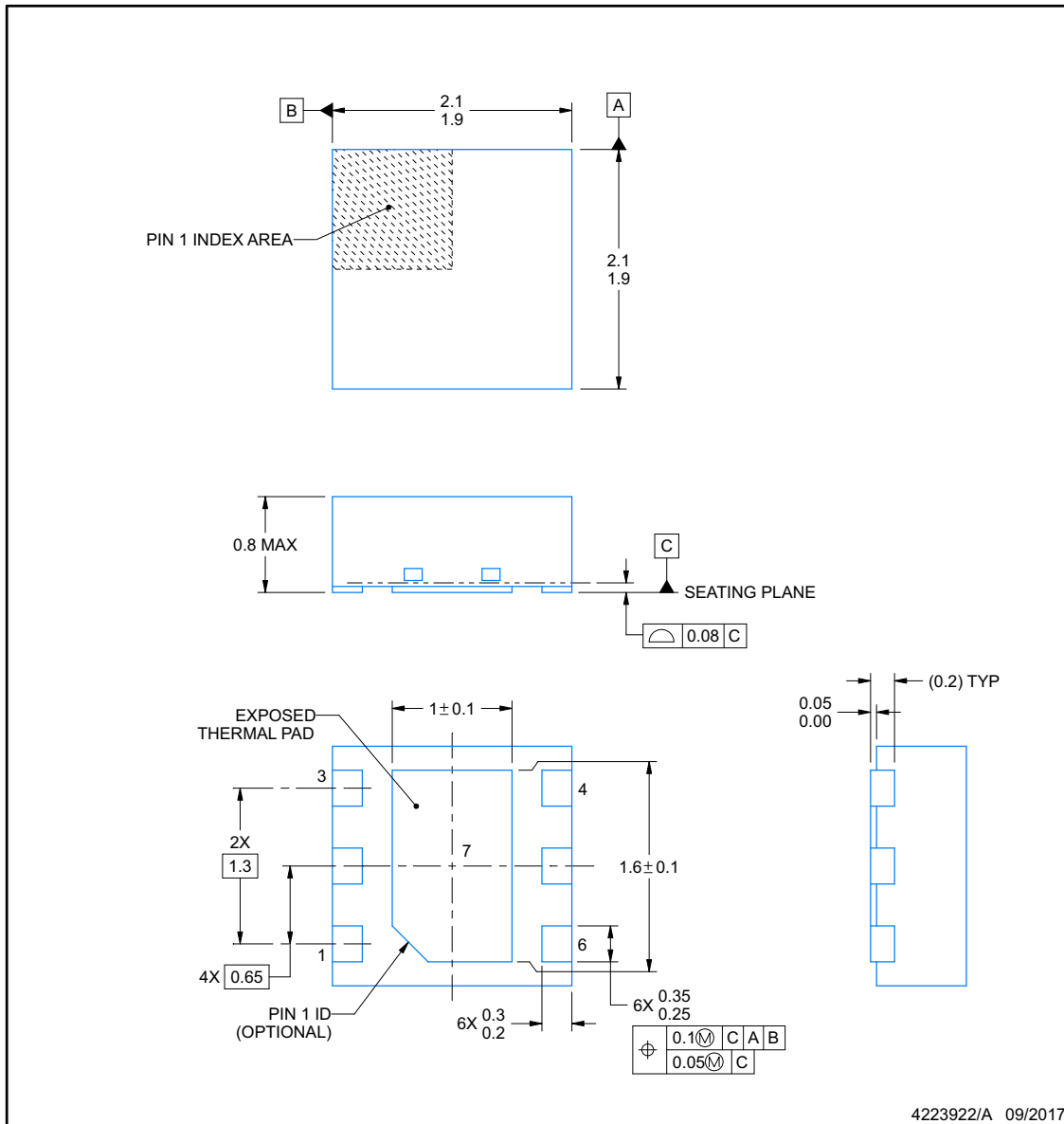
The following pages include mechanical, packaging, and orderable information. This information is the most current data available for the designated devices. This data is subject to change without notice and revision of this document. For browser-based versions of this data sheet, refer to the left-hand navigation.



**DRV0006B**

**PACKAGE OUTLINE**  
**WSO - 0.8 mm max height**

PLASTIC SMALL OUTLINE - NO LEAD



NOTES:

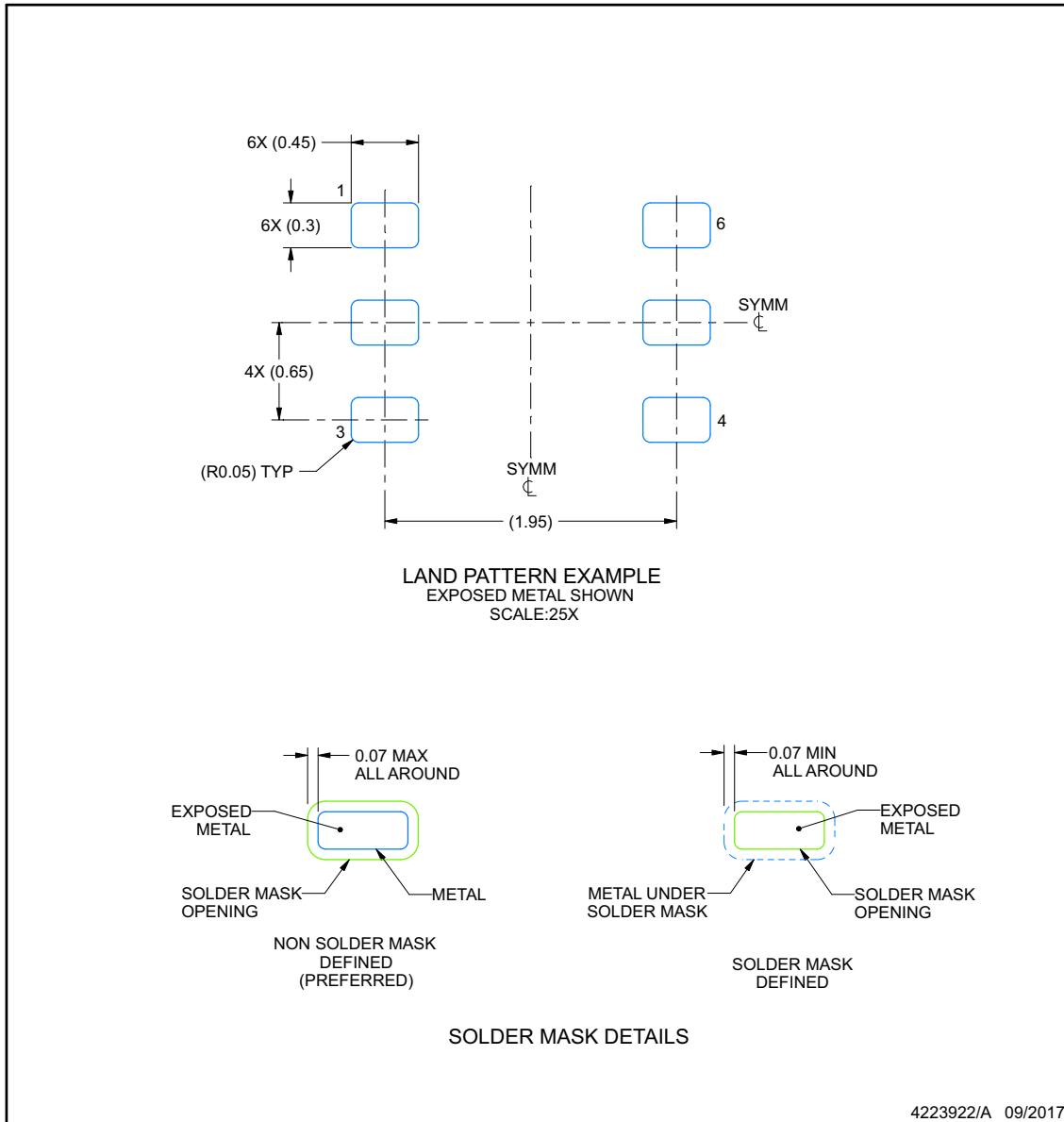
1. All linear dimensions are in millimeters. Any dimensions in parenthesis are for reference only. Dimensioning and tolerancing per ASME Y14.5M.
2. This drawing is subject to change without notice.

## EXAMPLE BOARD LAYOUT

**DRV0006B**

**WSN - 0.8 mm max height**

PLASTIC SMALL OUTLINE - NO LEAD



NOTES: (continued)

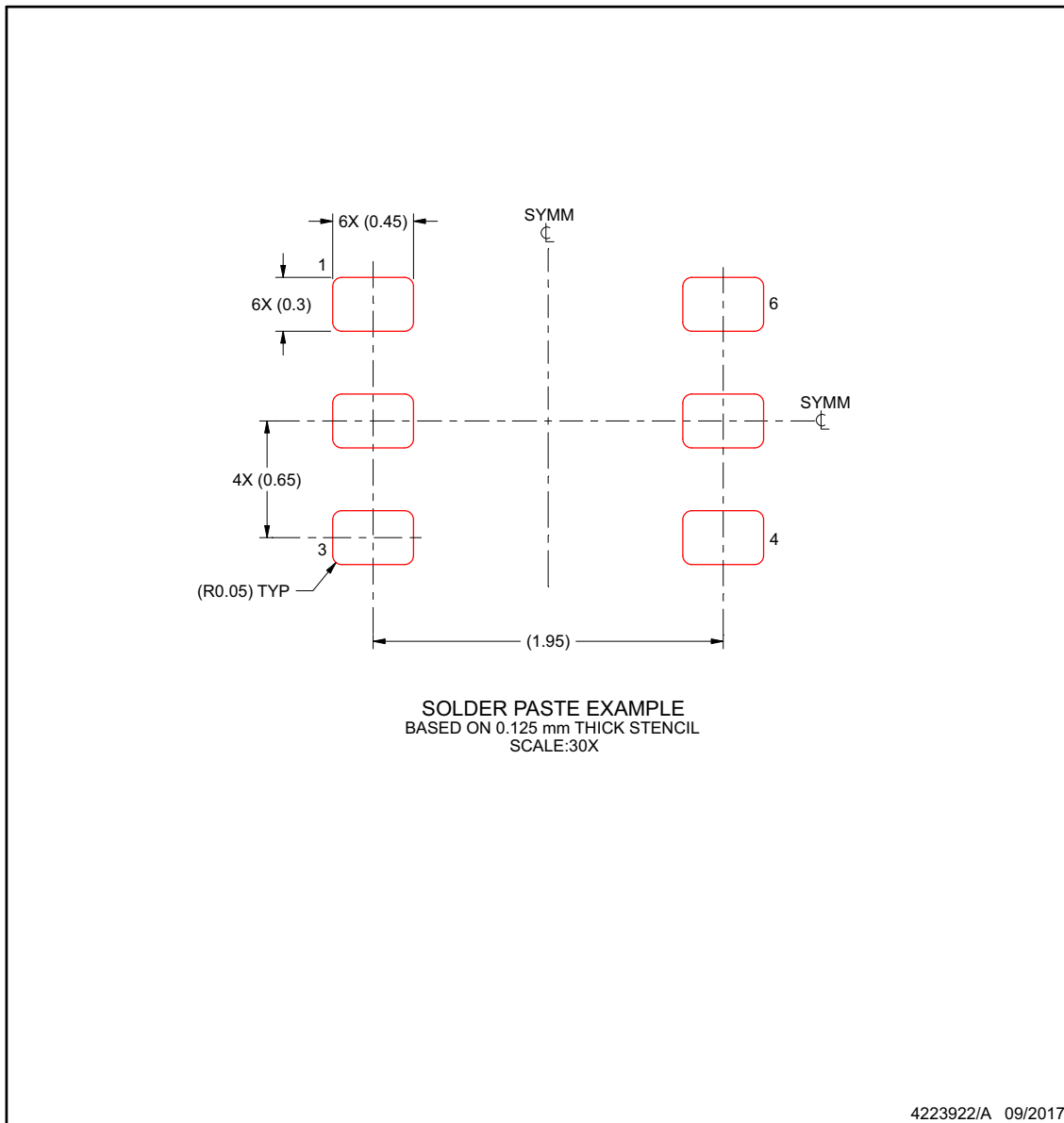
3. For more information, see Texas Instruments literature number SLUA271 ([www.ti.com/lit/slua271](http://www.ti.com/lit/slua271)).

**EXAMPLE STENCIL DESIGN**

**DRV0006B**

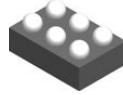
**WSN - 0.8 mm max height**

PLASTIC SMALL OUTLINE - NO LEAD



NOTES: (continued)

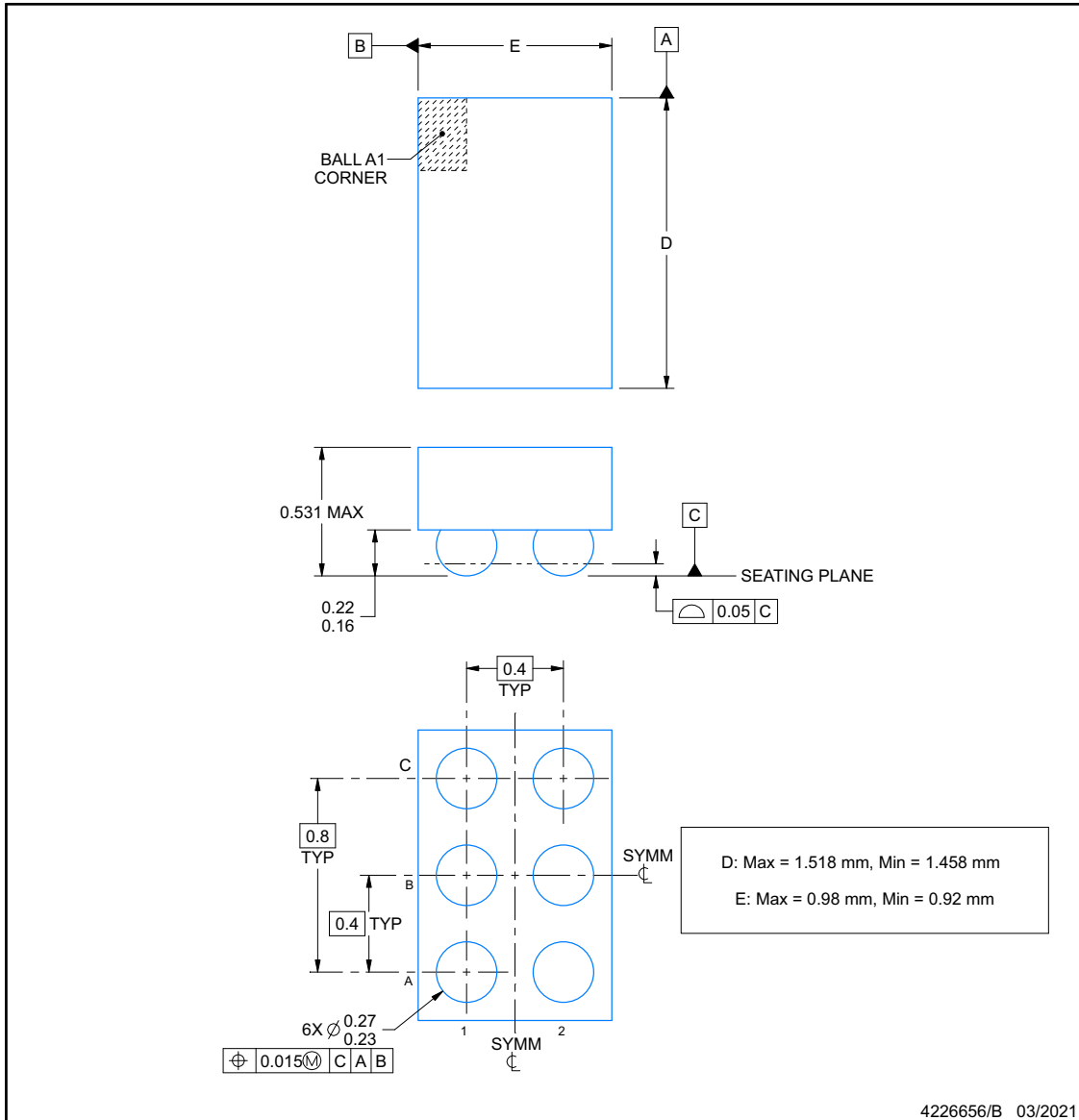
- 4. Laser cutting apertures with trapezoidal walls and rounded corners may offer better paste release. IPC-7525 may have alternate design recommendations.



**YBG0006-C01**

**PACKAGE OUTLINE**  
**DSBGA - 0.531 mm max height**

DIE SIZE BALL GRID ARRAY



NOTES:

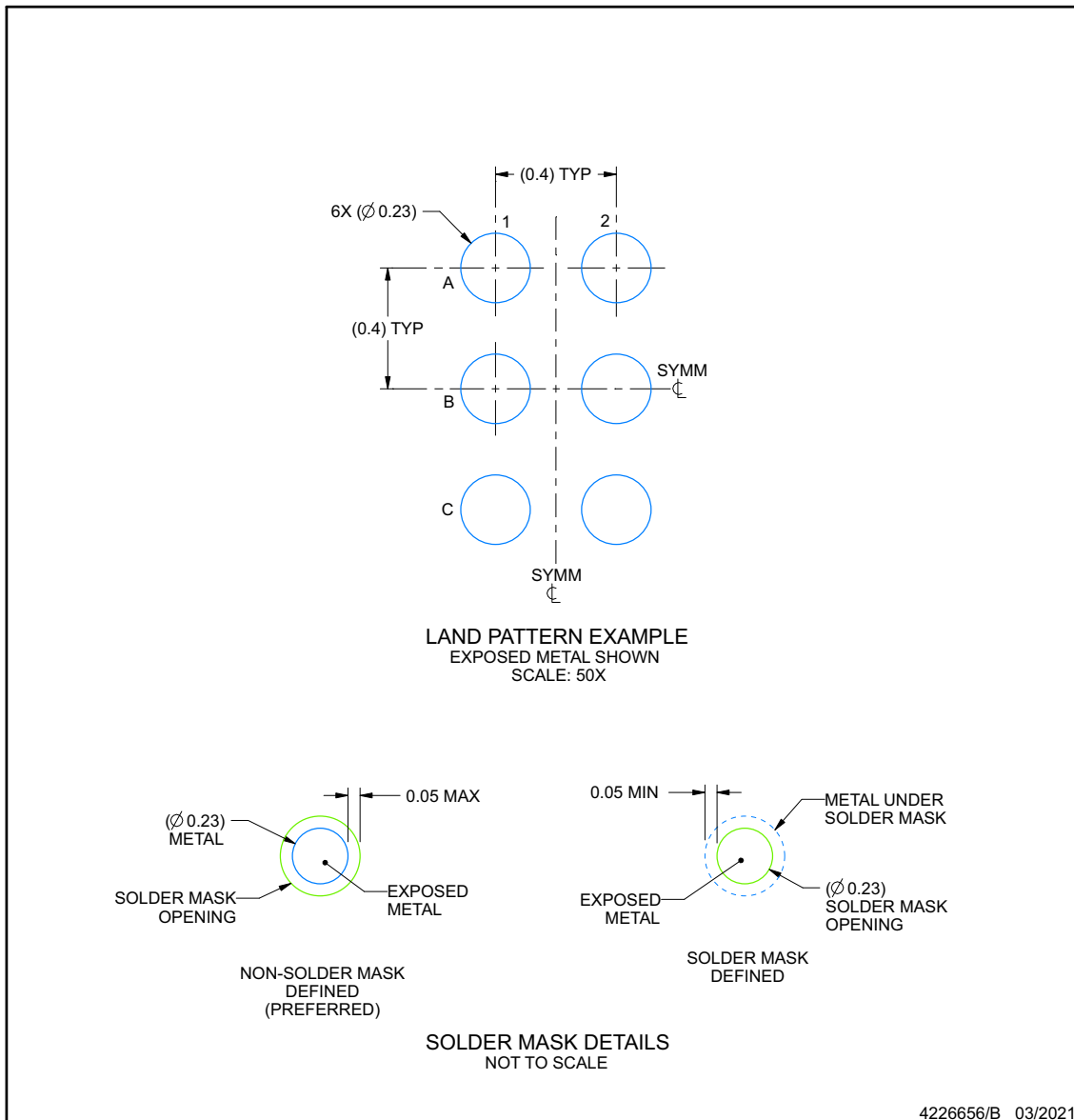
1. All linear dimensions are in millimeters. Any dimensions in parenthesis are for reference only. Dimensioning and tolerancing per ASME Y14.5M.
2. This drawing is subject to change without notice.

## EXAMPLE BOARD LAYOUT

**YBG0006-C01**

**DSBGA - 0.531 mm max height**

DIE SIZE BALL GRID ARRAY



NOTES: (continued)

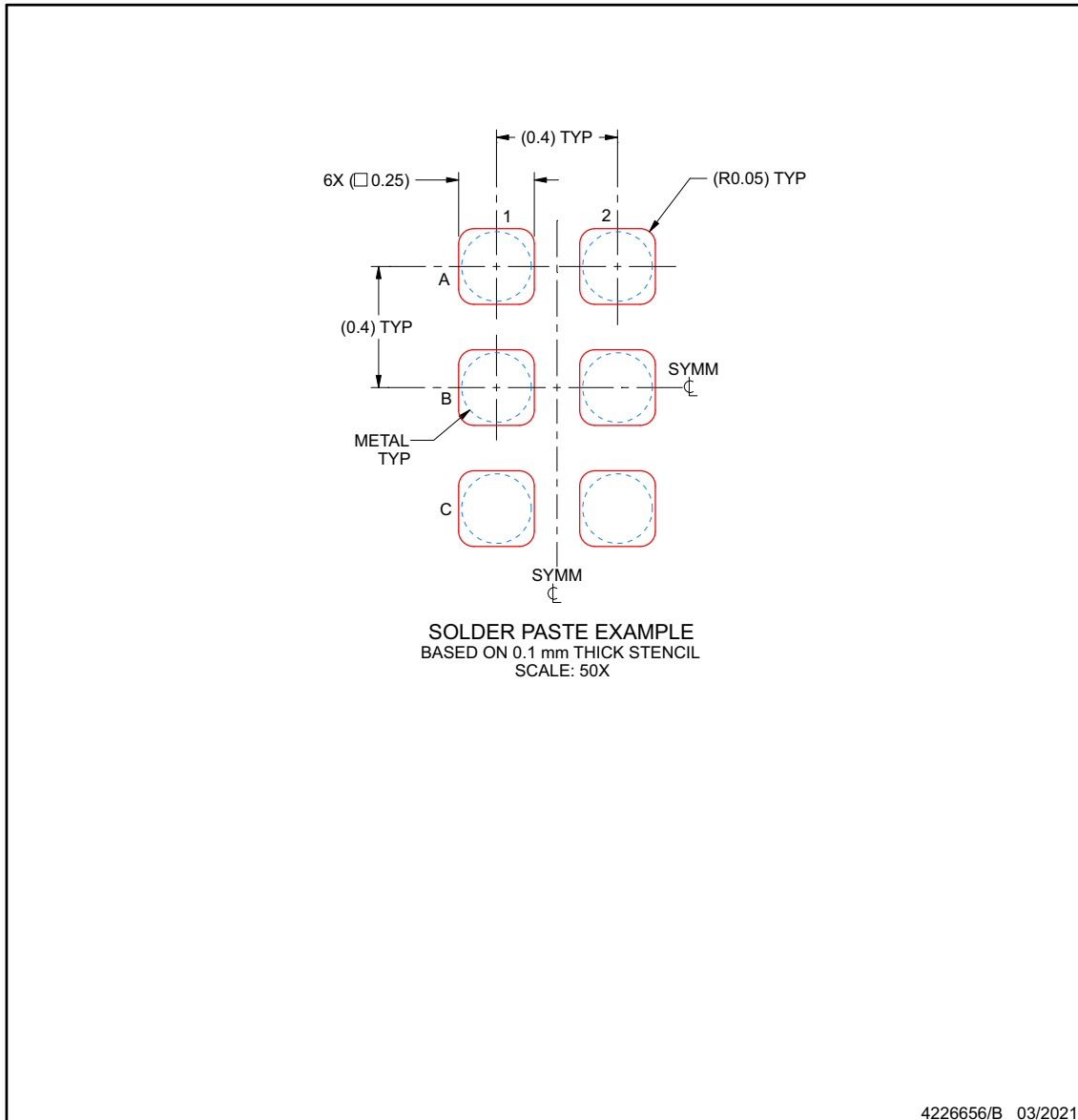
- Final dimensions may vary due to manufacturing tolerance considerations and also routing constraints. See Texas Instruments Literature No. SNVA009 ([www.ti.com/lit/snva009](http://www.ti.com/lit/snva009)).

## EXAMPLE STENCIL DESIGN

**YBG0006-C01**

**DSBGA - 0.531 mm max height**

DIE SIZE BALL GRID ARRAY



NOTES: (continued)

4. Laser cutting apertures with trapezoidal walls and rounded corners may offer better paste release.

**PACKAGING INFORMATION**

Orderable Device	Status (1)	Package Type	Package Drawing	Pins	Package Qty	Eco Plan (2)	Lead finish/ Ball material (6)	MSL Peak Temp (3)	Op Temp (°C)	Device Marking (4/5)	Samples
TMP117AIDRVR	ACTIVE	WSON	DRV	6	3000	RoHS & Green	NIPDAU	Level-1-260C-UNLIM	-55 to 150	T117	<a href="#">Samples</a>
TMP117AIYBGR	ACTIVE	DSBGA	YBG	6	3000	RoHS & Green	SAC396   SNAGCU	Level-1-260C-UNLIM	-55 to 150	E7	<a href="#">Samples</a>
TMP117MAIDRVR	ACTIVE	WSON	DRV	6	3000	RoHS & Green	NIPDAU	Level-1-260C-UNLIM	0 to 85	117M	<a href="#">Samples</a>
TMP117MAIYBGR	ACTIVE	DSBGA	YBG	6	3000	RoHS & Green	SAC396   SNAGCU	Level-1-260C-UNLIM	0 to 85	EQ	<a href="#">Samples</a>
TMP117NAIDRVR	ACTIVE	WSON	DRV	6	3000	RoHS & Green	NIPDAU	Level-1-260C-UNLIM	-55 to 150	117N	<a href="#">Samples</a>
TMP117NAIYBGR	ACTIVE	DSBGA	YBG	6	3000	RoHS & Green	SAC396   SNAGCU	Level-1-260C-UNLIM	-55 to 150	ER	<a href="#">Samples</a>

(1) The marketing status values are defined as follows:

**ACTIVE:** Product device recommended for new designs.

**LIFEBUY:** TI has announced that the device will be discontinued, and a lifetime-buy period is in effect.

**NRND:** Not recommended for new designs. Device is in production to support existing customers, but TI does not recommend using this part in a new design.

**PREVIEW:** Device has been announced but is not in production. Samples may or may not be available.

**OBSOLETE:** TI has discontinued the production of the device.

(2) **RoHS:** TI defines "RoHS" to mean semiconductor products that are compliant with the current EU RoHS requirements for all 10 RoHS substances, including the requirement that RoHS substance do not exceed 0.1% by weight in homogeneous materials. Where designed to be soldered at high temperatures, "RoHS" products are suitable for use in specified lead-free processes. TI may reference these types of products as "Pb-Free".

**RoHS Exempt:** TI defines "RoHS Exempt" to mean products that contain lead but are compliant with EU RoHS pursuant to a specific EU RoHS exemption.

**Green:** TI defines "Green" to mean the content of Chlorine (Cl) and Bromine (Br) based flame retardants meet JS709B low halogen requirements of <=1000ppm threshold. Antimony trioxide based flame retardants must also meet the <=1000ppm threshold requirement.

(3) MSL, Peak Temp. - The Moisture Sensitivity Level rating according to the JEDEC industry standard classifications, and peak solder temperature.

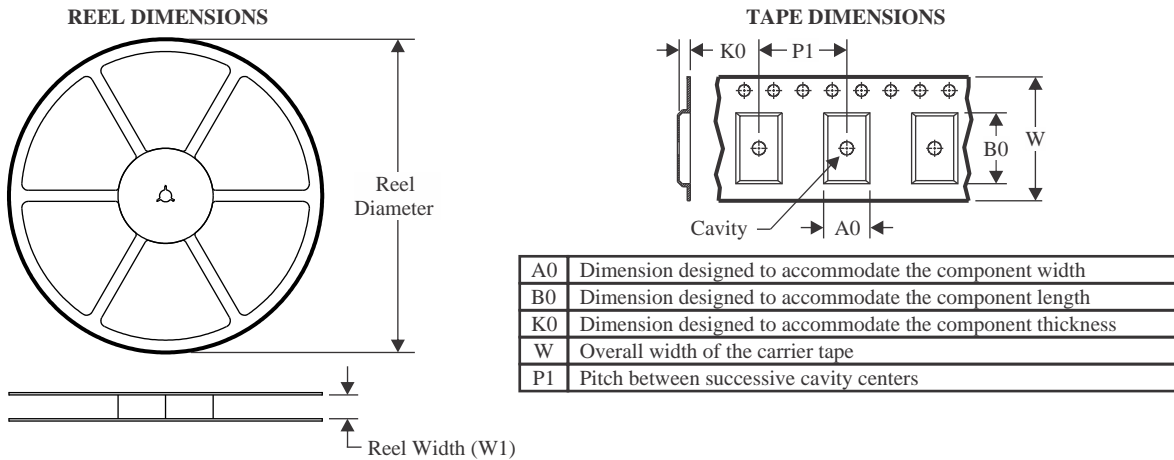
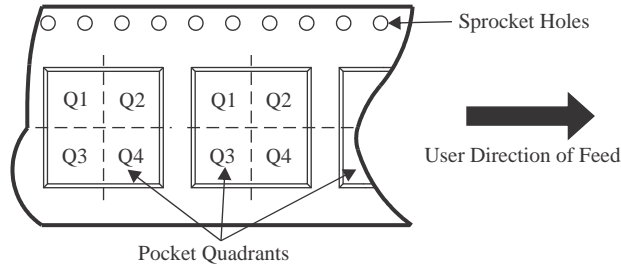
(4) There may be additional marking, which relates to the logo, the lot trace code information, or the environmental category on the device.

(5) Multiple Device Markings will be inside parentheses. Only one Device Marking contained in parentheses and separated by a "-" will appear on a device. If a line is indented then it is a continuation of the previous line and the two combined represent the entire Device Marking for that device.

(6) Lead finish/Ball material - Orderable Devices may have multiple material finish options. Finish options are separated by a vertical ruled line. Lead finish/Ball material values may wrap to two lines if the finish value exceeds the maximum column width.

**Important Information and Disclaimer:** The information provided on this page represents TI's knowledge and belief as of the date that it is provided. TI bases its knowledge and belief on information provided by third parties, and makes no representation or warranty as to the accuracy of such information. Efforts are underway to better integrate information from third parties. TI has taken and continues to take reasonable steps to provide representative and accurate information but may not have conducted destructive testing or chemical analysis on incoming materials and chemicals. TI and TI suppliers consider certain information to be proprietary, and thus CAS numbers and other limited information may not be available for release.

In no event shall TI's liability arising out of such information exceed the total purchase price of the TI part(s) at issue in this document sold by TI to Customer on an annual basis.

**TAPE AND REEL INFORMATION**

**QUADRANT ASSIGNMENTS FOR PIN 1 ORIENTATION IN TAPE**


\*All dimensions are nominal

Device	Package Type	Package Drawing	Pins	SPQ	Reel Diameter (mm)	Reel Width W1 (mm)	A0 (mm)	B0 (mm)	K0 (mm)	P1 (mm)	W (mm)	Pin1 Quadrant
TMP117AIDRVR	WSON	DRV	6	3000	180.0	8.4	2.3	2.3	1.15	4.0	8.0	Q2
TMP117AIYBGR	DSBGA	YBG	6	3000	180.0	8.4	1.04	1.58	0.59	2.0	8.0	Q1
TMP117MAIDRVR	WSON	DRV	6	3000	180.0	8.4	2.3	2.3	1.15	4.0	8.0	Q2
TMP117MAIYBGR	DSBGA	YBG	6	3000	180.0	8.4	1.04	1.58	0.59	2.0	8.0	Q1
TMP117NAIDRVR	WSON	DRV	6	3000	180.0	8.4	2.3	2.3	1.15	4.0	8.0	Q2
TMP117NAIYBGR	DSBGA	YBG	6	3000	180.0	8.4	1.04	1.58	0.59	2.0	8.0	Q1

**TAPE AND REEL BOX DIMENSIONS**


\*All dimensions are nominal

Device	Package Type	Package Drawing	Pins	SPQ	Length (mm)	Width (mm)	Height (mm)
TMP117AIDRVR	WSON	DRV	6	3000	210.0	185.0	35.0
TMP117AIYBGR	DSBGA	YBG	6	3000	182.0	182.0	20.0
TMP117MAIDRVR	WSON	DRV	6	3000	210.0	185.0	35.0
TMP117MAIYBGR	DSBGA	YBG	6	3000	182.0	182.0	20.0
TMP117NAIDRVR	WSON	DRV	6	3000	210.0	185.0	35.0
TMP117NAIYBGR	DSBGA	YBG	6	3000	182.0	182.0	20.0

## IMPORTANT NOTICE AND DISCLAIMER

TI PROVIDES TECHNICAL AND RELIABILITY DATA (INCLUDING DATA SHEETS), DESIGN RESOURCES (INCLUDING REFERENCE DESIGNS), APPLICATION OR OTHER DESIGN ADVICE, WEB TOOLS, SAFETY INFORMATION, AND OTHER RESOURCES "AS IS" AND WITH ALL FAULTS, AND DISCLAIMS ALL WARRANTIES, EXPRESS AND IMPLIED, INCLUDING WITHOUT LIMITATION ANY IMPLIED WARRANTIES OF MERCHANTABILITY, FITNESS FOR A PARTICULAR PURPOSE OR NON-INFRINGEMENT OF THIRD PARTY INTELLECTUAL PROPERTY RIGHTS.

These resources are intended for skilled developers designing with TI products. You are solely responsible for (1) selecting the appropriate TI products for your application, (2) designing, validating and testing your application, and (3) ensuring your application meets applicable standards, and any other safety, security, regulatory or other requirements.

These resources are subject to change without notice. TI grants you permission to use these resources only for development of an application that uses the TI products described in the resource. Other reproduction and display of these resources is prohibited. No license is granted to any other TI intellectual property right or to any third party intellectual property right. TI disclaims responsibility for, and you will fully indemnify TI and its representatives against, any claims, damages, costs, losses, and liabilities arising out of your use of these resources.

TI's products are provided subject to [TI's Terms of Sale](#) or other applicable terms available either on [ti.com](https://www.ti.com) or provided in conjunction with such TI products. TI's provision of these resources does not expand or otherwise alter TI's applicable warranties or warranty disclaimers for TI products.

TI objects to and rejects any additional or different terms you may have proposed.

Mailing Address: Texas Instruments, Post Office Box 655303, Dallas, Texas 75265  
Copyright © 2024, Texas Instruments Incorporated

## Looking for pricing, stock, or lifecycle information?

Click below to explore more details on WIN SOURCE:

 [View TMP117NAIDRVR on WIN SOURCE](#)

 [Texas Instruments](#) Information

## Optimize Your Supply Chain with WIN SOURCE Solutions

-  Global Sourcing Solution
-  Obsolete Management
-  Cost Control Management
-  Shortage Management
-  Alternative Solution
-  Excess Inventory Management