



THE DATASHEET OF MSMCJLCE33A



TPS2583x-Q1 Automotive USB Type-C® and BC1.2 5-V 3.5-A Output, 36-V Input Synchronous Step-Down DC/DC Regulator with Cable Compensation

1 Features

- AEC-Q100 Qualified for automotive applications:
 - Temperature grade 1: -40°C to $+125^{\circ}\text{C}$, T_A
 - HBM ESD classification level H2
 - CDM ESD classification level C5
- **Functional Safety-Capable**
 - Documentation available to aid functional safety system design
- Synchronous buck DC/DC regulator
 - Input voltage range: 4.5 V to 36 V
 - Output current: 3.5 A
 - 5.1-V output voltage with $\pm 1\%$ accuracy
 - Current mode control
 - Adjustable frequency: 300 kHz to 2.2 MHz
 - Frequency synchronization to external clock
 - FPWM with spread-spectrum dithering
 - Internal compensation for ease of use
- Compliant to USB-IF standards
 - USB Type-C® Rev 1.3
 - CC logic, V_{CONN} source and discharge
 - USB cable polarity detection ($\overline{\text{POL}}$)
 - CDP/SDP mode per USB BC1.2
 - Automatic DCP modes (TPS25831-Q1 only)
 - DCP shorted mode and YD/T 1591-2009
 - 2.7-V divider 3 mode
 - 1.2-V mode
- Optimized for USB power and communication
 - User-programmable USB current limit
 - Cable droop compensation up to 1.5 V
 - High bandwidth data switches on DP and DM (TPS25830-Q1 only)
 - NTC input for intelligent thermal management (TPS25831-Q1 only)
- Integrated protection

- V_{BUS} Short-to- V_{BAT} protection
- DP_IN and DM_IN Short-to- V_{BAT} and V_{BUS}
- CC1 and CC2 Short-to- V_{BAT} protection
- DP_IN, DM_IN, CCx IEC 61000-4-2 rated
 - $\pm 8\text{kV}$ contact and $\pm 15\text{-kV}$ air discharge
- Fault flag reports
- 32-pin QFN package with wettable flank

2 Applications

- [Automotive infotainment](#)
- [USB media hubs](#)
- [USB charger ports](#)

3 Description

The TPS2583x-Q1 is a USB Type-C and BC1.2 charging port controller that includes a synchronous DC/DC converter. With cable droop compensation, the V_{BUS} voltage remains constant regardless of load current, ensuring connected portable devices are charged at optimal current and voltage.

The TPS2583x-Q1 also integrates short-to-battery protection on V_{BUS} , CC1, CC2, DM_IN and DP_IN pins. These pins can withstand voltage up to 18 V.

The TPS25830-Q1 includes high bandwidth analog switches for DP and DM pass-through, while the TPS25831-Q1 includes a thermistor input pin and thermal warning flag for user programmable thermal overload protection.

Device Information⁽¹⁾

ORDERABLE PART NUMBER	PACKAGE	BODY SIZE (NOM)
TPS25830-Q1	VQFN (32)	5.00 mm × 5.00 mm
TPS25831-Q1	VQFN (32)	5.00 mm × 5.00 mm

(1) For detail part numbers for all available different options, see the orderable addendum at the end of the data sheet.

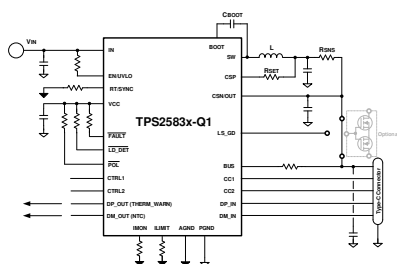

Simplified Schematic TPS2583x-Q1

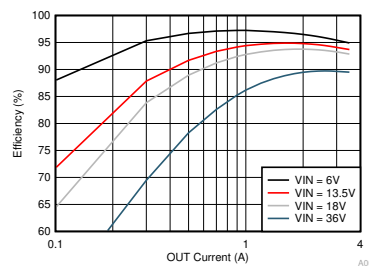

Buck Efficiency vs Output Current $f_{\text{sw}} = 400 \text{ kHz}$



Table of Contents

1 Features	1	10.3 Feature Description.....	25
2 Applications	1	10.4 Device Functional Modes.....	49
3 Description	1	11 Application and Implementation	53
4 Revision History	2	11.1 Application Information.....	53
5 Description (continued)	3	11.2 Typical Application.....	53
6 Device Comparison Table	3	12 Power Supply Recommendations	65
7 Pin Configuration and Functions	4	13 Layout	65
8 Specifications	7	13.1 Layout Guidelines.....	65
8.1 Absolute Maximum Ratings.....	7	13.2 Ground Plane and Thermal Considerations.....	66
8.2 ESD Ratings.....	8	13.3 Layout Example.....	67
8.3 Recommended Operating Conditions.....	8	14 Device and Documentation Support	68
8.4 Thermal Information.....	9	14.1 Documentation Support.....	68
8.5 Electrical Characteristics.....	9	14.2 Related Links.....	68
8.6 Timing Requirements.....	14	14.3 Receiving Notification of Documentation Updates..	68
8.7 Switching Characteristics.....	14	14.4 Support Resources.....	68
8.8 Typical Characteristics.....	17	14.5 Trademarks.....	68
9 Parameter Measurement Information	23	14.6 Electrostatic Discharge Caution.....	68
10 Detailed Description	24	14.7 Glossary.....	68
10.1 Overview.....	24	15 Mechanical, Packaging, and Orderable Information	68
10.2 Functional Block Diagram.....	25		

4 Revision History

NOTE: Page numbers for previous revisions may differ from page numbers in the current version.

Changes from Revision F (August 2020) to Revision G (March 2022)	Page
• Added RHB0032AA package to the data sheet.....	4
• Added the thermal information for RHB0032AA package.....	9
Changes from Revision E (May 2020) to Revision F (August 2020)	Page
• Updated the numbering format for tables, figures and cross-references throughout the document.....	1
• Added functional safety link to the <i>Features</i> section.....	1
Changes from Revision D (September 2019) to Revision E (May 2020)	Page
• Update PCB layout and guideline, EMC friendly	65
Changes from Revision C (July 2019) to Revision D (September 2019)	Page
• Changed the High-Bandwidth Analog Switch RDS_ON MAX from 5.6 to 6.3 and from 6.8 to 7.7 in the <i>Specifications Electrical Characteristics</i> table.....	7
• Added content for the TPS25830-Q1 timing requirement and <i>Figure 10-5</i> in the <i>Enable/UVLO and Start-up</i> section.....	26
• Updated the LS_GD requirements in the <i>Current Limit Setting using R_{LIMIT}</i> section.....	33
Changes from Revision B (June 2019) to Revision C (July 2019)	Page
• Changed TPS25830-Q1 to Production Data.....	1
• Changed Supply Voltage (IN PIN) IQ from 800 to 990 in the <i>Specifications Electrical Characteristics</i> table.....	7
Changes from Revision A (November 2018) to Revision B (May 2019)	Page
• Changed TPS25831-Q1 from Advance Information to Production Data	1
Changes from Revision * (June 2018) to Revision A (November 2018)	Page
• Changed device status from Product Preview to Advanced Information	1

5 Description (continued)

The synchronous buck regulator operates with current mode control and is internally compensated to simplify design. A resistor on the RT pin sets the switching frequency between 300 kHz and 2.2 MHz. Operating below 400 kHz results in better system efficiency. Operation above 2.1 MHz avoids the AM radio bands and allows for use of a smaller inductor.

The TPS2583x-Q1 integrates standard USB Type-C port controller functionality including Configuration Channel (CC) logic for 3-A and 1.5-A current advertisement. Battery Charging (Rev. 1.2) integration provides the required electrical signatures necessary for non-Type-C, legacy USB devices which use USB data line signaling to determine USB port current sourcing capabilities.

A precision current sense amplifier is included for user programmable cable droop compensation and current limit tuning. Cable compensation aids portable devices in charging at optimum current and voltage under heavy loads by changing the buck regulator output voltage linearly with load current to counteract the voltage drop due to wire resistance in automotive cabling. The V_{BUS} voltage measured at a connected portable device remains approximately constant, regardless of load current, allowing the portable device's battery charger to work optimally.

The USB specifications require current limiting of USB charging ports, but give system designers reasonable flexibility to choose overcurrent protection levels based on system requirements. The TPS25830x-Q1 uses a novel two-threshold current limit circuit allowing system designers to either program average current limit protection of the buck regulator, or optionally, current limit using an external NMOS between the CSN/OUT and BUS pins. The NFET implementation enables the TPS2583x-Q1 buck regulator to supply a 5-V output for other loads during an overcurrent fault condition on the USB port.

The TPS25830-Q1 includes high bandwidth analog switches for DP and DM pass-through. The TPS25831-Q1 includes a thermistor input pin and thermal warning flag for user programmable thermal overload protection.

Integrated protection features include cycle-by-cycle current limit, hiccup short-circuit protection, undervoltage lockout, V_{BUS} overvoltage and overcurrent, CC overvoltage and overcurrent, data line (D_x) short-to- V_{BUS} and V_{BAT} , and die overtemperature protection.

6 Device Comparison Table

PART NUMBER	PACKAGE	DCP AUTO	DP AND DM SWITCHES	NTC INPUT	THERMAL WARNING FLAG
TPS25830-Q1	VQFN (32)	No	Yes	No	No
TPS25831-Q1	VQFN (32)	Yes	No	Yes	Yes

7 Pin Configuration and Functions

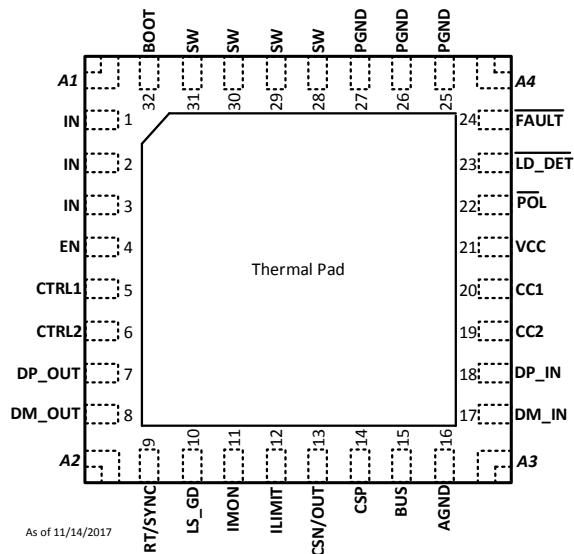

As of 11/14/2017

NOTES:

- 1) A1, A2, A3, and A4 are corner anchors for enhanced package stress performance.
- 2) A1, A2, A3, and A4 are electrically connected to the thermal pad.
- 3) A1, A2, A3, and A4 PCB lands should be electrically isolated or electrically connected to thermal pad and PGND.

Figure 7-1. TPS25830QWRHBRQ1 Package 32-Pin (VQFN) Top View (1)

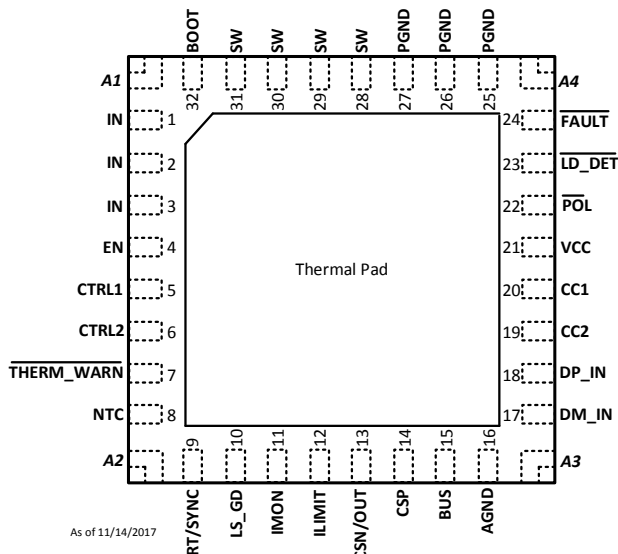

As of 11/14/2017

NOTES:

- 1) A1, A2, A3, and A4 are corner anchors for enhanced package stress performance.
- 2) A1, A2, A3, and A4 are electrically connected to the thermal pad.
- 3) A1, A2, A3, and A4 PCB lands should be electrically isolated or electrically connected to thermal pad and PGND.

Figure 7-2. TPS25831QWRHBRQ1 Package 32-Pin (VQFN) Top View (1)

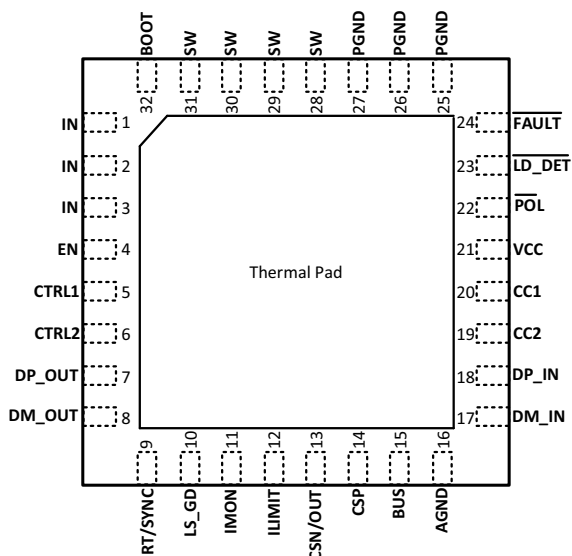

Figure 7-3. TPS25830QCWRHBRQ1 Package 32-Pin (VQFN) Top View (2)

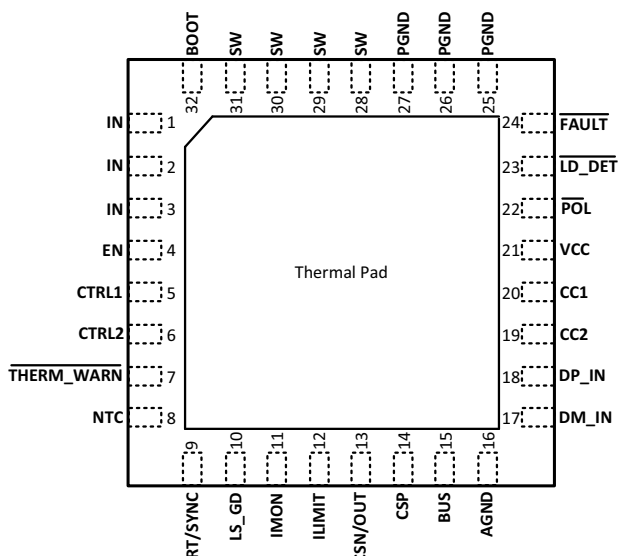

Figure 7-4. TPS25831QCWRHBRQ1 Package 32-Pin (VQFN) Top View (2)

Table 7-1. Pin Functions

NAME	830-Q1 NO.	831-Q1 NO.	TYPE (3)	I/O	DESCRIPTION
AGND	16	16	G	–	Analog ground terminal. Ground reference for internal references and logic. All electrical parameters are measured with respect to this pin. Connect to system ground on PCB.
BOOT	32	32	P		Boot-strap capacitor connection for HS FET driver. Connect a high quality 100-nF capacitor from this pin to the SW pin.
BUS	15	15	A	I	VBUS discharge input. Connect to VBUS on USB Connector.
CC1	20	20	A	I/O	Analog input and output. Connect to Type-C CC1 pin.
CC2	19	19	A	I/O	Analog input and output. Connect to Type-C CC2 pin.
CSN/OUT	13	13	A	I	Negative input of current sense amplifier, also buck output for internal voltage regulation.
CSP	14	14	A	I	Positive input of current sense amplifier.
CTRL1	5	5	A	I	Logic-level control inputs for device/system configuration (see Truth Table).
CTRL2	6	6	A	I	Logic-level control inputs for device/system configuration (see Truth Table).
DM_IN	17	17	A		DM data line. Connect to USB connector.
DM_OUT	8	–	A		DM data line. Connect to USB host controller.
DP_IN	18	18	A		DP data line. Connect to USB connector.
DP_OUT	7	–	A		DP data line. Connect to USB host controller.
EN/UVLO	4	4	A		Enable pin. Do not float. High = on, Low = off. Can be tied to VIN. Precision enable input allows adjustable UVLO by external resistor divider.
FAULT	24	24	A	O	Active LOW open-drain output. Asserted during fault conditions (see Table 10-4).
ILIMIT	12	12	A		External resistor used to set the current-limit threshold (see Table 10-2).
IMON	11	11	A		External resistor used to set the max cable comp voltage at full load current.
IN	1, 2, 3	1, 2, 3	P	I	Input Supply to regulator. Connect a high-quality bypass capacitor(s) directly to this pin and PGND.
LD_DET	23	23	A	O	Active LOW open-drain output. Asserted when a Type-C UFP is identified on the CC lines.
LS_GD	10	10	A		External NMOS gate driver. For TPS25830-Q1, LS_GD pin must be pulled up through a 2.2-kΩ resistor under average current limit mode (see Current Limit Setting using R_ILIMIT).
NTC	–	8		I	Input for negative temperature coefficient resistor divider. Use to monitor external PCB temperature (see Thermal Sensing with NTC (TPS25831-Q1)).
PGND	25, 26, 27	25, 26, 27	G	–	Power ground terminal. Connect to system ground and AGND. Connect to bypass capacitor with short wide traces.
POL	22	22	A	O	Active LOW open-drain output. Signals which Type-C CC pin is connected to the CC line. This gives cable orientation information needed to mux the super speed lines. Asserted when the CC2 pin is connected to the CC line in the cable.
RT/SYNC	9	9	A		Resistor Timing or External Clock input. An internal amplifier holds this terminal at a fixed voltage when using an external resistor to ground to set the switching frequency. If the terminal is pulled above the PLL upper threshold, a mode change occurs and the terminal becomes a synchronization input. The internal amplifier is disabled and the terminal is a high impedance clock input to the internal PLL. If clocking edges stop, the internal amplifier is re-enabled and the operating mode returns to resistor frequency programming.
SW	28, 29, 30, 31	28, 29, 30, 31	P		Switching output of the regulator. Internally connected to source of the HS FET and drain of the LS FET. Connect to power inductor.

Table 7-1. Pin Functions (continued)

NAME	830-Q1 NO.	831-Q1 NO.	TYPE ⁽³⁾	I/O	DESCRIPTION
THERM_WA RN	–	7	A	O	Active LOW open-drain output. Asserted when voltage at the NTC pin increases above the thermal warning threshold.
VCC	21	21	P		Output of internal bias supply. Used as supply to internal control circuits. Connect a high quality 2.2- μ F capacitor from this pin to GND.

- (1) For the package drawing, please refer to RHB0032R at the end of the data sheet.
- (2) For the package drawing, please refer to RHB0032AA at the end of the data sheet.
- (3) A = Analog, P = Power, G = Ground.

8 Specifications

8.1 Absolute Maximum Ratings

Voltages are with respect to GND (unless otherwise noted)⁽¹⁾

PARAMETER		MIN	MAX	UNIT
Input voltage	IN to PGND	-0.3	40	V
	OUT to PGND	-0.3	20	
	EN to AGND	-0.3	VIN + 0.3	
	CSP to AGND	-0.3	20	
	CSN to AGND	-0.3	20	
	BUS to AGND	-0.3	18	
	RT/SYNC to AGND	-0.3	6	
	CTRL1 or CTRL2 to AGND	-0.3	6	
	AGND to PGND	-0.3	0.3	
Output voltage	SW to PGND	-0.3	VIN + 0.3	V
	SW to PGND (less than 10 ns transients)	-3.5	40	
	BOOT to SW	-0.3	6	
	VCC to AGND	-0.3	6	
	LS_GD	-0.3	18	
Voltage range	CC1 or CC2 to AGND	-0.3	18	V
	DP_IN, DM_IN to AGND	-0.3	18	
	DP_OUT, DM_OUT to AGND (TPS25830-Q1 only)	-0.3	6	
	FAULT, POL, LD_DET to AGND	-0.3	6	
	THERM_WARN, NTC to AGND (TPS25831-Q1 only)	-0.3	6	
	ILIMIT or IMON to AGND	-0.3	6	
Pin positive source current, I _{VCC}	VCC Source Current		5	mA
Pin positive source current, I _{SRC}	CC1, CC2		Internally Limited	A
Pin positive sink current, I _{SNK}	CC1, CC2 (while applying VCONN)		1	A
Pin positive sink current, I _{SNK}	FAULT, POL, LD_DET		Internally Limited	A
	THERM_WARN (TPS25831-Q1 only)		Internally Limited	
I/O current	DP_IN to DP_OUT, or DM_IN to DM_OUT in SDP, CDP (TPS25830-Q1 only)	-100	100	mA
	DP_IN to DM_IN in DCP Auto Mode (TPS25831-Q1 only)	-35	35	
T _J	Junction temperature	-40	150	°C
T _{stg}	Storage temperature	-65	150	°C

- (1) Stresses beyond those listed under *Absolute Maximum Rating* may cause permanent damage to the device. These are stress ratings only, which do not imply functional operation of the device at these or any other conditions beyond those indicated under *Recommended Operating Condition*. Exposure to absolute-maximum-rated conditions for extended periods may affect device reliability.

8.2 ESD Ratings

			VALUE	UNIT	
V _(ESD)	Electrostatic discharge	Human body model (HBM), per AEC Q100-002 ⁽¹⁾	±2000 ⁽²⁾	V	
		Charged device model (CDM), per AEC Q100-011	Corner pins (1, 8, 9, 17, 25 and 32)		±750 ⁽³⁾
			Other pins		±750 ⁽³⁾
		IEC 61000-4-2 contact discharge	DP_IN, DM_IN, CC1 and CC2 pins		±8000 ⁽⁴⁾
		IEC 61000-4-2 air-gap discharge	DP_IN, DM_IN, CC1 and CC2 pins		±15000 ⁽⁴⁾

(1) AEC Q100-002 indicates that HBM stressing shall be in accordance with the ANSI/ESDA/JEDEC JS-001 specification.

(2) The passing level per AEC-Q100 Classification H2.

(3) The passing level per AEC-Q100 Classification C5.

(4) Surges per IEC61000-4-2, 1999 applied between DP_IN, DM_IN, CC1, CC2 and output ground of the TPS2583x-Q1 evaluation module. Addition 0.22u cap is needed on CCx pins.

8.3 Recommended Operating Conditions

Voltages are with respect to GND (unless otherwise noted)

			MIN	NOM	MAX	UNIT
V _I	Input voltage	IN to PGND	4.5		36	V
		EN	0		V _{IN}	
		VCC when driven from external regulator	0		5.5	
		DP_IN, DM_IN	0		3.6	
		DP_OUT, DM_OUT (TPS25830-Q1 only)	0		3.6	
		NTC (TPS25831-Q1 only)	0		VCC	
		CTRL1, CTRL2	0		VCC	
		RT/SYNC when driven by external clock	0		VCC	
V _{PU}	Pull up voltage	FAULT, LD_DET, POL	0		VCC	
		THERM_WARN (TPS25831-Q1 only)	0		VCC	
V _O	Output voltage	CSN/OUT	0		6.5	
I _O	Output current	Buck regulator output current	0		3.5	A
		DP_IN to DP_OUT or DM_IN to DM_OUT Continuous current in SDP, CDP	-30		30	mA
		DP_IN to DM_IN Continuous current in BC1.2 DCP Mode	-15		15	
I _{SRC}	Source current	CC1 or CC2 source current when supplying VCONN			250	
I _{SNK}	Sink current	FAULT, LD_DET, POL			10	
		THERM_WARN (TPS25831-Q1 only)			10	
I _I	Input current	Continuous current into the CSP pin			200	μA
R _{EXT}	External resistnace	R _{IMON} , R _{LIMIT}	0		100	kΩ
T _J		Operating junction temperature	-40		125 ⁽¹⁾	°C

(1) Operating at junction temperatures greater than 125°C is possible, however lifetime will be degraded.

8.4 Thermal Information

THERMAL METRIC ⁽¹⁾		TPS2583x-Q1		UNIT
		RHB0032R (VQFN)	RHB0032AA (VQFN)	
		32 PINS	32 PINS	
R _{θJA}	Junction-to-ambient thermal resistance	28.7	29.4	°C/W
R _{θJC(top)}	Junction-to-case (top) thermal resistance	17.6	18.6	°C/W
R _{θJB}	Junction-to-board thermal resistance	7.2	9.7	°C/W
Ψ _{JT}	Junction-to-top characterization parameter	0.2	0.2	°C/W
Ψ _{JB}	Junction-to-board characterization parameter	7.2	9.7	°C/W
R _{θJC(bot)}	Junction-to-case (bottom) thermal resistance	1	2.3	°C/W

(1) For more information about traditional and new thermal metrics, see the [Semiconductor and IC Package Thermal Metrics](#) application report.

8.5 Electrical Characteristics

Limits apply over the junction temperature (T_J) range of -40°C to +150°C; V_{IN} = 13.5 V, f_{SW} = 400 kHz, C_{VCC} = 2.2 μF, R_{SNS} = 15 mΩ, R_{IMON} = 13 kΩ, R_{LIMIT} = 13 kΩ, R_{SET} = 300 Ω unless otherwise stated. Minimum and maximum limits are specified through test, design or statistical correlation. Typical values represent the most likely parametric norm at T_J = 25°C, and are provided for reference purposes only.

PARAMETER		TEST CONDITIONS	MIN	TYP	MAX	UNIT
SUPPLY VOLTAGE (IN PIN)						
V _{IN}	Operating input voltage range		4.5		36	V
I _Q	Operating quiescent current (non switching)	V _{EN/UVLO} = V _{IN} , CTRL1 = CTRL2 = V _{CC} , V _{CSN} = 8V, CC1 or CC2 = R _D , CC2 or CC1 = open		700	990	μA
I _{Q-SB}	Standby quiescent current	V _{EN/UVLO} = V _{IN} , CTRL1 = CTRL2 = V _{CC} , CC1 and CC2 = open			290	μA
I _{SD}	Shutdown quiescent current; measured at IN pin.	EN = 0		10	16	μA
ENABLE and UVLO (EN/UVLO PIN)						
V _{EN/UVLO_VCC_H}	EN/UVLO input level required to turn on internal LDO	V _{EN/UVLO} rising threshold			1.14	V
V _{EN/UVLO_VCC_L}	EN/UVLO input level required to turn off internal LDO	V _{EN/UVLO} falling threshold	0.3			V
V _{EN/UVLO_H}	EN/UVLO input level required to turn on state machine	V _{EN/UVLO} rising threshold	1.140	1.200	1.260	V
V _{EN/UVLO_HYS}	Hysteresis	V _{EN/UVLO} falling threshold		90		mV
I _{LKG_EN/UVLO}	Enable input leakage current	V _{EN/UVLO} = 3.3 V		0.5		μA
INTERNAL LDO						
V _{BOOT_UVLO}	Bootstrap voltage UVLO threshold			2.2		V
V _{CC}	Internal LDO output voltage appearing on VCC pin	6 V ≤ V _{IN} ≤ 36 V	4.75	5	5.25	V
V _{CC_UVLO_R}	Rising UVLO threshold		3.4	3.6	3.8	V
V _{CC_UVLO_HYS}	Hysteresis			600		mV
CURRENT LIMIT VOLTAGE (CSP - CSN/OUT PINS) TO ACTIVATE BUCK AVG CURRENT LIMITING						
(V _{CSP} - V _{CSN/OUT})	Current limit voltage buck regulator control loop	V _{CSN} = 5 V, R _{SET} = 300 Ω, R _{LIMIT} = 13 kΩ, R _{IMON} = 13 kΩ, -40°C ≤ T _J ≤ 125°C	43.5	46	48.5	mV
(V _{CSP} - V _{CSN/OUT})	Current limit voltage buck regulator control loop	V _{CSN} = 5 V, R _{SET} = 300 Ω, R _{LIMIT} = 13 kΩ, R _{IMON} = 13 kΩ, -40°C ≤ T _J ≤ 150°C	42.5	46	49.5	mV

8.5 Electrical Characteristics (continued)

Limits apply over the junction temperature (T_J) range of -40°C to $+150^{\circ}\text{C}$; $V_{IN} = 13.5\text{ V}$, $f_{SW} = 400\text{ kHz}$, $C_{VCC} = 2.2\text{ }\mu\text{F}$, $R_{SNS} = 15\text{ m}\Omega$, $R_{IMON} = 13\text{ k}\Omega$, $R_{LIMIT} = 13\text{ k}\Omega$, $R_{SET} = 300\text{ }\Omega$ unless otherwise stated. Minimum and maximum limits are specified through test, design or statistical correlation. Typical values represent the most likely parametric norm at $T_J = 25^{\circ}\text{C}$, and are provided for reference purposes only.

PARAMETER		TEST CONDITIONS	MIN	TYP	MAX	UNIT
$(V_{CSP} - V_{CSN/OUT})$	Current limit voltage buck regulator control loop	$V_{CSN} = 5\text{ V}$, $R_{SET} = 300\text{ }\Omega$, $R_{LIMIT} = 26.1\text{ k}\Omega$, $R_{IMON} = 13\text{ k}\Omega$, $-40^{\circ}\text{C} \leq T_J \leq 125^{\circ}\text{C}$	20	22.5	25	mV
$(V_{CSP} - V_{CSN/OUT})$	Current limit voltage buck regulator control loop	$V_{CSN} = 5\text{ V}$, $R_{SET} = 300\text{ }\Omega$, $R_{LIMIT} = 26.1\text{ k}\Omega$, $R_{IMON} = 13\text{ k}\Omega$, $-40^{\circ}\text{C} \leq T_J \leq 150^{\circ}\text{C}$	19	22.5	26	mV
CURRENT LIMIT VOLTAGE (CSP - CSN/OUT PINS) TO ACTIVATE EXTERNAL NFET CURRENT LIMITING						
$(V_{CSP} - V_{CSN/OUT})$	Current limit voltage NFET control loop	$V_{CSN} = 5\text{ V}$, $R_{SET} = 300\text{ }\Omega$, $R_{LIMIT} = 6.8\text{ k}\Omega$, $R_{IMON} = 13\text{ k}\Omega$, $-40^{\circ}\text{C} \leq T_J \leq 125^{\circ}\text{C}$	40	43	46	mV
$(V_{CSP} - V_{CSN/OUT})$	Current limit voltage NFET control loop	$V_{CSN} = 5\text{ V}$, $R_{SET} = 300\text{ }\Omega$, $R_{LIMIT} = 6.8\text{ k}\Omega$, $R_{IMON} = 13\text{ k}\Omega$, $-40^{\circ}\text{C} \leq T_J \leq 150^{\circ}\text{C}$	38.5	43	47.5	mV
$(V_{CSP} - V_{CSN/OUT})$	Current limit voltage NFET control loop	$V_{CSN} = 5\text{ V}$, $R_{SET} = 300\text{ }\Omega$, $R_{LIMIT} = 13.7\text{ k}\Omega$, $R_{IMON} = 13\text{ k}\Omega$, $-40^{\circ}\text{C} \leq T_J \leq 125^{\circ}\text{C}$	18	21	24	mV
$(V_{CSP} - V_{CSN/OUT})$	Current limit voltage NFET control loop	$V_{CSN} = 5\text{ V}$, $R_{SET} = 300\text{ }\Omega$, $R_{LIMIT} = 13.7\text{ k}\Omega$, $R_{IMON} = 13\text{ k}\Omega$, $-40^{\circ}\text{C} \leq T_J \leq 150^{\circ}\text{C}$	17	21	25	mV
CURRENT LIMIT - BUCK REGULATOR PEAK CURRENT LIMIT						
$I_{L-SC-HS}$	High-side current limit		4.6	5.4	6.2	A
$I_{L-SC-LS}$	Low-side current limit		3.5	4	4.5	A
$I_{L-NEG-LS}$	Low-side negative current limit		-3.1	-2.1	-1.3	A
CABLE COMPENSATION VOLTAGE						
V_{IMON}	Cable compensation voltage	$(V_{CSP} - V_{CSN}) = 46\text{ mV}$, $R_{SET} = 300\text{ }\Omega$, $R_{LIMIT} = 13\text{ k}\Omega$, $R_{IMON} = 13\text{ k}\Omega$	0.935	1	1.065	V
V_{IMON}	Cable compensation voltage	$(V_{CSP} - V_{CSN}) = 23\text{ mV}$, $R_{SET} = 300\text{ }\Omega$, $R_{LIMIT} = 13\text{ k}\Omega$, $R_{IMON} = 13\text{ k}\Omega$	0.435	0.5	0.565	V
V_{IMON}	Cable compensation voltage (internal clamp)	$(V_{CSP} - V_{CSN}) = 46\text{ mV}$, $R_{SET} = 300\text{ }\Omega$, $R_{LIMIT} = 13\text{ k}\Omega$, $R_{IMON} = \text{open}$		1.8		V
BUCK OUTPUT VOLTAGE (CSN/OUT PIN)						
$V_{CSN/OUT}$	Output voltage	CC1 or CC2 pulldown resistance = R_d , $R_{IMON} = 0\text{ }\Omega$, $R_{LIMIT} = 0\text{ }\Omega$	5.05	5.10	5.15	V
$V_{CSN/OUT}$	Output voltage accuracy	CC1 or CC2 pulldown resistance = R_d , $R_{IMON} = 0\text{ }\Omega$, $R_{LIMIT} = 0\text{ }\Omega$	-1		1	%
V_{CSN/OUT_OV}	Overshoot level on CSN/OUT pin which buck regulator stops switching	$V_{CSN/OUT}$ rising	7.1	7.5	7.9	V
V_{CSN/OUT_OV_HYS}	Hysteresis			500		mV
V_{HC}	CSN / OUT pin voltage required to trigger short circuit hiccup mode			2		V
V_{DROP}	Dropout voltage ($V_{IN} - V_{OUT}$)	$V_{IN} = V_{OUT} + V_{DROP}$, $V_{OUT} = 5.1\text{ V}$, $I_{OUT} = 3\text{ A}$		150		mV
BUCK REGULATOR INTERNAL RESISTANCE						
$R_{DS-ON-HS}$	High-side MOSFET ON-resistance	Load = 3 A, $T_J = 25^{\circ}\text{C}$		40	45	m Ω
$R_{DS-ON-HS}$	High-side MOSFET ON-resistance	Load = 3 A, $-40^{\circ}\text{C} \leq T_J \leq 125^{\circ}\text{C}$		40	68	m Ω
$R_{DS-ON-HS}$	High-side MOSFET ON-resistance	Load = 3 A, $-40^{\circ}\text{C} \leq T_J \leq 150^{\circ}\text{C}$		40	75	m Ω
$R_{DS-ON-LS}$	Low-side MOSFET ON-resistance	Load = 3 A, $T_J = 25^{\circ}\text{C}$		35	41	m Ω
$R_{DS-ON-LS}$	Low-side MOSFET ON-resistance	Load = 3 A, $-40^{\circ}\text{C} \leq T_J \leq 125^{\circ}\text{C}$		35	60	m Ω

8.5 Electrical Characteristics (continued)

Limits apply over the junction temperature (T_J) range of -40°C to $+150^{\circ}\text{C}$; $V_{IN} = 13.5\text{ V}$, $f_{SW} = 400\text{ kHz}$, $C_{VCC} = 2.2\text{ }\mu\text{F}$, $R_{SNS} = 15\text{ m}\Omega$, $R_{IMON} = 13\text{ k}\Omega$, $R_{LIMIT} = 13\text{ k}\Omega$, $R_{SET} = 300\text{ }\Omega$ unless otherwise stated. Minimum and maximum limits are specified through test, design or statistical correlation. Typical values represent the most likely parametric norm at $T_J = 25^{\circ}\text{C}$, and are provided for reference purposes only.

PARAMETER		TEST CONDITIONS	MIN	TYP	MAX	UNIT
$R_{DS-ON-LS}$	Low-side MOSFET ON-resistance	Load = 3 A, $-40^{\circ}\text{C} \leq T_J \leq 150^{\circ}\text{C}$		35	68	m Ω
NFET GATE DRIVE (LS_GD PIN)						
V_{LS_GD}	NFET gate drive output voltage	$V_{CSN/OUT} = 5.1\text{ V}$, $C_G = 1000\text{ pF}$ (see Figure 9-4)	9.5	11	12.5	V
$I_{LS_DR_SRC}$	NFET gate drive output source current	$V_{CSN/OUT} = 5.1\text{ V}$, $C_G = 1000\text{ pF}$	2	3	4	μA
$I_{LS_DR_SNK}$	NFET gate drive output sink current	$V_{CSN/OUT} = 5.1\text{ V}$, $C_G = 1000\text{ pF}$	20	35	50	μA
$V_{LS_GD_UVLO_R}$	$V_{CSN/OUT}$ rising threshold for LS_GD operation	$V_{CSN/OUT}$ rising	2.85	3	3.15	V
$V_{LS_GD_UVLO_HYS}$	Hysteresis			80		mV
BUS DISCHARGE (BUS PIN)						
R_{BUS_DCHG}	BUS discharge resistance	$V_{BUS} = 4\text{ V}$	250	320	550	Ω
$V_{BUS_NO_DCHG}$	Falling threshold for VBUS not discharged				0.8	V
$R_{BUS_DCHG_BLEED}$	BUS bleed resistance	$V_{BUS} = 4\text{ V}$, No sink termination on CC lines, Time $> t_{W_BUS_DCHG}$	100	130	200	k Ω
V_{BUS_OV}	Rising threshold for BUS pin overvoltage protection	V_{BUS} rising	6.6	7	7.3	V
$V_{BUS_OV_HYS}$	Hysteresis			180		mV
$R_{BUS_DCHG_18V}$	Discharge resistance for BUS	$V_{BUS} = 18\text{ V}$, measure leakage current		29		k Ω
$R_{BUS_DCHG_8V}$	Discharge resistance for BUS	$V_{BUS} = 8\text{ V}$, measure leakage current		35		k Ω
CC1 AND CC2 - VCONN POWER SWITCH (CC1 AND CC2 PINS)						
R_{DS-ON}	On-state resistance	$I_{CCn} = 250\text{ mA}$, $T_J = 25^{\circ}\text{C}$		500	540	m Ω
R_{DS-ON}	On-state resistance	$I_{CCn} = 250\text{ mA}$, $-40^{\circ}\text{C} \leq T_J \leq 125^{\circ}\text{C}$,		500	830	m Ω
R_{DS-ON}	On-state resistance	$I_{CCn} = 250\text{ mA}$, $-40^{\circ}\text{C} \leq T_J \leq 150^{\circ}\text{C}$,		500	920	m Ω
I_{OS_CCn}	VCONN short circuit current limit	Short circuit current limit	350	430	550	mA
R_{VCONN_DCHG}	Discharge resistance	CC pin that was providing V_{VCONN} before detach: $V_{CCX} = 4\text{ V}$	650	850	1100	Ω
V_{TH}	Falling threshold for discharged	CC pin that was providing V_{VCONN} before detach	570	600	630	mV
V_{TH}	Discharged threshold hysteresis			100		mV
V_{CCx_OV}	Rising threshold for CCn pin overvoltage protection	CC pin voltage V_{CCn} rising	5.8	6.1	6.4	V
$V_{CCx_OV_HYS}$	Hysteresis			150		mV
$R_{CCn_DCHG_18V}$	Discharge resistance for CCn	CC pin voltage $V_{CCn} = 18\text{ V}$, measure leakage current		40		k Ω
$R_{CCn_DCHG_8V}$	Discharge resistance for CCn	CC pin voltage $V_{CCn} = 8\text{ V}$, measure leakage current		86		k Ω
CC1/CC2 CONNECT MANAGEMENT: DANGLING ELECTRONICALLY MARKED CABLE MODE						
I_{SRC_CCn}	Sourcing current on the passthrough CC line	CC pin voltage $0\text{ V} \leq V_{CCn} \leq 1.5\text{ V}$	64	80	96	μA
I_{SRC_CCn}	Sourcing current on the Ra CC line	CC pin voltage $0\text{ V} \leq V_{CCn} \leq 1.5\text{ V}$	64	80	96	μA
CC1/CC2 CONNECT MANAGEMENT: UFP MODE (TPS25830-Q1)						
I_{SRC_CCn}	Sourcing current	$V_{CTRL1} = V_{CC}$ and $V_{CTRL2} = V_{CC}$, CC pin voltage: $0\text{ V} \leq V_{CCn} \leq 1.5\text{ V}$ (with CDP mode)	308	330	354	μA

8.5 Electrical Characteristics (continued)

Limits apply over the junction temperature (T_J) range of -40°C to $+150^{\circ}\text{C}$; $V_{IN} = 13.5\text{ V}$, $f_{SW} = 400\text{ kHz}$, $C_{VCC} = 2.2\text{ }\mu\text{F}$, $R_{SNS} = 15\text{ m}\Omega$, $R_{IMON} = 13\text{ k}\Omega$, $R_{LIMIT} = 13\text{ k}\Omega$, $R_{SET} = 300\text{ }\Omega$ unless otherwise stated. Minimum and maximum limits are specified through test, design or statistical correlation. Typical values represent the most likely parametric norm at $T_J = 25^{\circ}\text{C}$, and are provided for reference purposes only.

PARAMETER		TEST CONDITIONS	MIN	TYP	MAX	UNIT
I_{SRC_CCn}	Sourcing current	$V_{CTRL1} = V_{CC}$ and $V_{CTRL2} = \text{GND}$, CC pin voltage: $0\text{ V} \leq V_{CCn} \leq 1.5\text{ V}$ (with SDP mode)	168	180	192	μA
CC1/CC2 CONNECT MANAGEMENT: UFP MODE (TPS25831-Q1)						
I_{SRC_CCn}	Sourcing current	$V_{CTRL1} = V_{CC}$ and $V_{CTRL2} = V_{CC}$, CC pin voltage: $0\text{ V} \leq V_{CCn} \leq 1.5\text{ V}$ (with CDP mode)	308	330	354	μA
I_{SRC_CCn}	Sourcing current	$V_{CTRL1} = V_{CC}$ and $V_{CTRL2} = \text{GND}$, CC pin voltage: $0\text{ V} \leq V_{CCn} \leq 1.5\text{ V}$ (with SDP mode)	168	180	192	μA
I_{SRC_CCn}	Sourcing current	$V_{CTRL1} = \text{GND}$ and $V_{CTRL2} = V_{CC}$, CC pin voltage: $0\text{ V} \leq V_{CCn} \leq 1.5\text{ V}$ (with DCP auto mode)	308	330	354	μA
I_{REV}	Reverse leakage current	CCx is the CC pin under test, CCy is the other CC pin. CC pin voltage $V_{CCx} = 5.5\text{ V}$, $CCy = 0\text{V}$ or floating, $V_{EN} = 0\text{ V}$, I_{REV} is current into CCx pin		0	5	μA
I_{REV}	Reverse leakage current	CCx is the CC pin under test, CCy is the other CC pin. CC pin voltage $V_{CCx} = 5.5\text{ V}$, $CCy = 0$, $V_{EN} = V_{IN}$, I_{REV} is current into CCx pin under test		6	10	μA
FAULT, LD_DET, POL						
V_{OL}	FAULT Output low voltage	$I_{SNK_PIN} = 0.5\text{ mA}$			250	mV
I_{OFF}	FAULT Off-state leakage	$V_{PIN} = 5.5\text{ V}$			1	μA
V_{OL}	LD_DET, POL Output low voltage	$I_{SNK_PIN} = 0.5\text{ mA}$			250	mV
I_{OFF}	LD_DET, POL Off-state leakage	$V_{PIN} = 5.5\text{ V}$			1	μA
THERM_WARN (TPS25831-Q1)						
V_{OL}	THERM_WARN Output low voltage	$I_{SNK_PIN} = 0.5\text{ mA}$			250	mV
I_{OFF}	THERM_WARN Off-state leakage	$V_{PIN} = 5.5\text{ V}$			1	μA
CTRL1, CTRL2 - LOGIC INPUTS						
V_{IH}	Rising threshold voltage			1.48	2	V
V_{IL}	Falling threshold voltage		0.85	1.30		V
V_{HYS}	Hysteresis			180		mV
I_{IN}	Input current		-1		1	μA
DP_IN AND DM_IN OVERVOLTAGE PROTECTION						
$V_{Dx_IN_OV}$	Rising threshold for Dx_IN overvoltage protection	DP_IN or DM_IN rising	3.7	3.9	4.15	V
	Hysteresis			100		mV
$R_{Dx_IN_DCHG_18V}$	Discharge resistance for Dx_IN	$V_{Dx_IN} = 18\text{V}$, measure leakage current		94		k Ω
$R_{Dx_IN_DCHG_5V}$	Discharge resistance for Dx_IN	$V_{Dx_IN} = 5\text{V}$, measure leakage current		416		k Ω
HIGH-BANDWIDTH ANALOG SWITCH (TPS25830-Q1)						
R_{DS_ON}	DP and DM switch on-resistance	$V_{DP_OUT} = V_{DM_OUT} = 0\text{ V}$, $I_{DP_IN} = I_{DM_IN} = 30\text{ mA}$		3.4	6.3	Ω
R_{DS_ON}	DP and DM switch on-resistance	$V_{DP_OUT} = V_{DM_OUT} = 2.4\text{ V}$, $I_{DP_IN} = I_{DM_IN} = -15\text{ mA}$		4.3	7.7	Ω

8.5 Electrical Characteristics (continued)

Limits apply over the junction temperature (T_J) range of -40°C to $+150^{\circ}\text{C}$; $V_{IN} = 13.5\text{ V}$, $f_{SW} = 400\text{ kHz}$, $C_{VCC} = 2.2\text{ }\mu\text{F}$, $R_{SNS} = 15\text{ m}\Omega$, $R_{IMON} = 13\text{ k}\Omega$, $R_{LIMIT} = 13\text{ k}\Omega$, $R_{SET} = 300\text{ }\Omega$ unless otherwise stated. Minimum and maximum limits are specified through test, design or statistical correlation. Typical values represent the most likely parametric norm at $T_J = 25^{\circ}\text{C}$, and are provided for reference purposes only.

PARAMETER		TEST CONDITIONS	MIN	TYP	MAX	UNIT
$ \Delta R_{DS_ON} $	Switch resistance mismatch between DP and DM channels	$V_{DP_OUT} = V_{DM_OUT} = 0\text{ V}$, $I_{DP_IN} = I_{DM_IN} = 30\text{ mA}$		0.05	0.15	Ω
$ \Delta R_{DS_ON} $	Switch resistance mismatch between DP and DM channels	$V_{DP_OUT} = V_{DM_OUT} = 2.4\text{ V}$, $I_{DP_IN} = I_{DM_IN} = -15\text{ mA}$		0.05	0.15	Ω
C_{IO_OFF}	DP/DM switch off-state capacitance	$V_{EN} = 0\text{ V}$, $V_{DP_IN} = V_{DM_IN} = 0.3\text{ V}$, $V_{ac} = 0.03\text{ V}_{PP}$, $f = 1\text{ MHz}$		6.7		pF
C_{IO_ON}	DP/DM switch on-state capacitance	$V_{DP_IN} = V_{DM_IN} = 0.3\text{ V}$, $V_{ac} = 0.03\text{ V}_{PP}$, $f = 1\text{ MHz}$		10		pF
O_{IRR}	Off-state isolation	$V_{EN} = 0\text{ V}$, $f = 250\text{ MHz}$		9		dB
X_{TALK}	On-state cross-channel isolation	$f = 250\text{ MHz}$		29		dB
$I_{kg(OFF)}$	Off-state leakage current, DP_OUT and DM_OUT	$V_{EN} = 0\text{ V}$, $V_{DP_IN} = V_{DM_IN} = 3.6\text{ V}$, $V_{DP_OUT} = V_{DM_OUT} = 0\text{ V}$, measure I_{DP_OUT} and I_{DM_OUT}		0.1	1.5	μA
BW	Bandwidth (-3 dB)	$R_L = 50\text{ }\Omega$		800		MHz
CHARGING DOWNSTREAM PORT (CDP) DETECT						
V_{DM_SRC}	DM_IN CDP output voltage	$V_{DP_IN} = 0.6\text{ V}$, $-250\text{ }\mu\text{A} < I_{DM_IN} < 0\text{ }\mu\text{A}$	0.5	0.6	0.7	V
V_{DAT_REF}	DP_IN rising lower window threshold for V_{DM_SRC} activation		0.36	0.38	0.4	V
V_{DAT_REF}	Hysteresis			50		mV
V_{LGC_SRC}	DP_IN rising upper window threshold for V_{DM_SRC} deactivation		0.8	0.84	0.88	V
$V_{LGC_SRC_HYS}$	Hysteresis			100		mV
I_{DP_SINK}	DP_IN sink current	$V_{DP_IN} = 0.6\text{ V}$	40	70	100	μA
BC 1.2 DOWNSTREAM CHARGING PORT (TPS25831-Q1)						
R_{DPM_SHORT}	DP_IN and DM_IN shorting resistance			135	200	Ω
DIVIDER3 MODE (TPS25831-Q1)						
V_{DP_DIV3}	DP_IN output voltage		2.57	2.7	2.84	V
V_{DM_DIV3}	DM_IN output voltage		2.57	2.7	2.84	V
R_{DP_DIV3}	DP_IN output impedance	$I_{DP_IN} = -5\text{ }\mu\text{A}$	24	30	36	k Ω
R_{DM_DIV3}	DM_IN output impedance	$I_{DM_IN} = -5\text{ }\mu\text{A}$	24	30	36	k Ω
1.2-V MODE (TPS25831-Q1)						
$V_{DP_1.2V}$	DP_IN output voltage		1.12	1.2	1.26	V
$V_{DM_1.2V}$	DM_IN output voltage		1.12	1.2	1.26	V
$R_{DP_1.2V}$	DP_IN output impedance	$I_{DP_IN} = -5\text{ }\mu\text{A}$	84	100	126	k Ω
$R_{DM_1.2V}$	DM_IN output impedance	$I_{DM_IN} = -5\text{ }\mu\text{A}$	84	100	126	k Ω
RT/SYNC THRESHOLD (RT/SYNC PIN)						
$V_{IH_RT/SYNC}$	RT/SYNC high threshold for external clock synchronization	Amplitude of SYNC clock AC signal (measured at SYNC pin)	3.5			V
$V_{IL_RT/SYNC}$	RT/SYNC low threshold for external clock synchronization	Amplitude of SYNC clock AC signal (measured at SYNC pin)			0.8	V
NTC TEMPERATURE SENSING (TPS25831-Q1)						
V_{WARN_HIGH}	Temperature warning threshold rising		$V_{CC} \times 0.475$	$V_{CC} \times 0.5$	$V_{CC} \times 0.525$	V
V_{WARN_HYS}	Hysteresis			$V_{CC} \times 0.1$		V

8.5 Electrical Characteristics (continued)

Limits apply over the junction temperature (T_J) range of -40°C to $+150^{\circ}\text{C}$; $V_{IN} = 13.5\text{ V}$, $f_{SW} = 400\text{ kHz}$, $C_{VCC} = 2.2\ \mu\text{F}$, $R_{SNS} = 15\text{ m}\Omega$, $R_{IMON} = 13\text{ k}\Omega$, $R_{LIMIT} = 13\text{ k}\Omega$, $R_{SET} = 300\ \Omega$ unless otherwise stated. Minimum and maximum limits are specified through test, design or statistical correlation. Typical values represent the most likely parametric norm at $T_J = 25^{\circ}\text{C}$, and are provided for reference purposes only.

PARAMETER		TEST CONDITIONS	MIN	TYP	MAX	UNIT
V_{SD_HIGH}	Temperature shutdown threshold rising		$V_{CC} \times 0.618$	$V_{CC} \times 0.65$	$V_{CC} \times 0.683$	V
V_{SD_HYS}	Hysteresis			$V_{CC} \times 0.1$		V
THERMAL SHUTDOWN						
T_{SD}	Thermal shutdown	Shutdown threshold		160		$^{\circ}\text{C}$
		Recovery threshold		140		$^{\circ}\text{C}$

8.6 Timing Requirements

Limits apply over the junction temperature (T_J) range of -40°C to $+150^{\circ}\text{C}$; $V_{IN} = 13.5\text{ V}$, $f_{SW} = 400\text{ kHz}$, $C_{VCC} = 2.2\ \mu\text{F}$, $R_{SNS} = 15\text{ m}\Omega$, $R_{IMON} = 13\text{ k}\Omega$, $R_{LIMIT} = 13\text{ k}\Omega$, $R_{SET} = 300\ \Omega$ unless otherwise stated. Minimum and maximum limits are specified through test, design or statistical correlation. Typical values represent the most likely parametric norm at $T_J = 25^{\circ}\text{C}$, and are provided for reference purposes only.

		MIN	NOM	MAX	UNIT
SYNC (RT/SYNC PIN) WITH EXTERNAL CLOCK					
f_{SYNC}	Switching frequency using external clock on RT/SYNC pin		300	2300	kHz
T_{SYNC_MIN}	Minimum SYNC input pulse width	$f_{SYNC} = 400\text{ kHz}$, $V_{RT/SYNC} > V_{IH_RT/SYNC}$, $V_{RT/SYNC} < V_{IL_RT/SYNC}$		100	ns
T_{LOCK_IN}	PLL lock time		100		μs

8.7 Switching Characteristics

Limits apply over the junction temperature (T_J) range of -40°C to $+150^{\circ}\text{C}$; $V_{IN} = 13.5\text{ V}$, $f_{SW} = 400\text{ kHz}$, $C_{VCC} = 2.2\ \mu\text{F}$, $R_{SNS} = 15\text{ m}\Omega$, $R_{IMON} = 13\text{ k}\Omega$, $R_{LIMIT} = 13\text{ k}\Omega$, $R_{SET} = 300\ \Omega$ unless otherwise stated. Minimum and maximum limits are specified through test, design or statistical correlation. Typical values represent the most likely parametric norm at $T_J = 25^{\circ}\text{C}$, and are provided for reference purposes only.

PARAMETER		TEST CONDITIONS	MIN	TYP	MAX	UNIT
SOFT START						
T_{SS}	Internal soft-start time	The time of internal reference to increase from 0 V to 1.0 V	3	5	7	ms
HICCUP MODE						
N_{OC}	Number of cycles that LS current limit is tripped to enter Hiccup mode			128		Cycles
T_{OC}	Hiccup retry delay time			118		ms
SW (SW PIN)						
T_{ON_MIN}	Minimum turnon-time			105		ns
T_{ON_MAX}	Maximum turnon-time, HS timeout in dropout			7.5		μs
T_{OFF_MIN}	Minimum turnoff time			80		ns
D_{max}	Maximum switch duty cycle			98		%
TIMING RESISTOR AND INTERNAL CLOCK						
f_{SW_RANGE}	Switching frequency range using RT mode		300		2300	kHz
f_{SW}	Switching frequency	$R_T = 49.9\text{ k}\Omega$	360	400	440	kHz
	Switching frequency	$R_T = 8.87\text{ k}\Omega$	1953	2100	2247	kHz

8.7 Switching Characteristics (continued)

Limits apply over the junction temperature (T_J) range of -40°C to $+150^{\circ}\text{C}$; $V_{IN} = 13.5\text{ V}$, $f_{SW} = 400\text{ kHz}$, $C_{VCC} = 2.2\text{ }\mu\text{F}$, $R_{SNS} = 15\text{ m}\Omega$, $R_{IMON} = 13\text{ k}\Omega$, $R_{LIMIT} = 13\text{ k}\Omega$, $R_{SET} = 300\text{ }\Omega$ unless otherwise stated. Minimum and maximum limits are specified through test, design or statistical correlation. Typical values represent the most likely parametric norm at $T_J = 25^{\circ}\text{C}$, and are provided for reference purposes only.

PARAMETER		TEST CONDITIONS	MIN	TYP	MAX	UNIT
f_{SS}	Frequency span of spread spectrum operation			± 6		%
BUS DISCHARGE						
$t_{DEGA_OUT_DCHG}$	Discharge asserting deglitch		5.0	12.5	23.4	ms
$t_{W_BUS_DCHG}$	V_{BUS} discharge time after sink termination removed from CC lines	$V_{BUS} = 1\text{ V}$, time $I_{SNK_OUT} > 1\text{ mA}$ after sink termination removed from CC lines	150	266	400	ms
CC1/CC2 - VCONN POWER SWITCH 5.1 kΩ on one CC pin and 1 kΩ on the other						
t_r	Output voltage rise time	$C_L = 1\text{ }\mu\text{F}$, $R_L = 100\text{ }\Omega$ (measured from 10% to 90% of final value)	0.78	1.1	1.95	ms
t_f	Output voltage fall time		0.18	0.32	0.37	
t_{on}	Output voltage turnon-time	$C_L = 1\text{ }\mu\text{F}$, $R_L = 100\text{ }\Omega$	4.1	6.2	8.5	ms
t_{off}	Output voltage turnoff time		0.5	1	1.6	
CC1/CC2 VCONN POWER SWITCH: CURRENT LIMIT						
t_{IOS}	Short circuit response time			15		μs
CC1/CC2 - CONNECT MANAGEMENT - ATTACH AND DETACH DEGLITCH						
$t_{DEGA_CC_ATT}$	Attach asserting deglitch		1.1	2.08	3.29	ms
$t_{DEGD_CC_DET}$	Detach asserting deglitch for exiting UFP state		6.98	12.7	19.4	ms
CC1/CC2 - CONNECT MANAGEMENT - ATTACHED MODE 5.1-kΩ or 1-kΩ termination on at least one CC pin						
$t_{DEGA_CC_SHORT}$	Detach, R_d and R_a asserting deglitch		78	195	366	μs
$t_{DEGA_CC_LONG}$	Long deglitch		87	150	217	ms
CC1/CC2 - CONNECT MANAGEMENT - VCONN DISCHARGED MODE						
$t_{W_CC_DCHG}$	Discharge wait time		37	66	99	ms
NFET DRIVER						
t_r	V_{LS_DR} rise time	$V_{OUT} = 5.1\text{ V}$, NFET = CSD87502Q2, time from LS_GD 10% to 90%		1000		μs
t_f	V_{LS_DR} fall time	$V_{OUT} = 5.1\text{ V}$, NFET = CSD87502Q2, time from LS_GD time 90% to 10%		100		μs
CURRENT LIMIT - EXTERNAL NFET CONNECTED BETWEEN CSN/OUT AND BUS, LS_GD CONNECTED TO FET GATE						
$t_{OC_HIC_ON}$	ON-time during hiccup mode			2		ms
$t_{OC_HIC_OFF}$	OFF-time during hiccup mode			263		ms
FAULT DUE TO V_{BUS} OC, V_{BUS} OV, DP OV, DM OV, CC OV, CC OC						
t_{DEGLA}	Asserting deglitch time		5.5	8.2	11.5	ms
t_{DEGLD}	De-asserting deglitch time		5.5	8.2	11.5	ms
LD_DET, POL						
t_{DEGLA}	Asserting deglitch time		88	150	220	ms
t_{DEGLD}	De-asserting deglitch time		7.0	12.7	19.4	ms
THERM_WARN (TPS25831-Q1)						
t_{DEGLA}	Asserting deglitch time			0		ms
t_{DEGLD}	De-asserting deglitch time			0		ms
HIGH-BANDWIDTH ANALOG SWITCH (TPS25830-Q1)						
t_{pd}	Analog switch propagation delay			0.14		ns

8.7 Switching Characteristics (continued)

Limits apply over the junction temperature (T_J) range of -40°C to $+150^{\circ}\text{C}$; $V_{IN} = 13.5\text{ V}$, $f_{SW} = 400\text{ kHz}$, $C_{VCC} = 2.2\text{ }\mu\text{F}$, $R_{SNS} = 15\text{ m}\Omega$, $R_{IMON} = 13\text{ k}\Omega$, $R_{LIMIT} = 13\text{ k}\Omega$, $R_{SET} = 300\text{ }\Omega$ unless otherwise stated. Minimum and maximum limits are specified through test, design or statistical correlation. Typical values represent the most likely parametric norm at $T_J = 25^{\circ}\text{C}$, and are provided for reference purposes only.

PARAMETER		TEST CONDITIONS	MIN	TYP	MAX	UNIT
t_{SK}	Analog switch skew between opposite transitions of the same port ($t_{PHL} - t_{PLH}$)			0.02		ns
t_{OV_Dn}	DP_IN and DM_IN overvoltage protection response time			2		μs

8.8 Typical Characteristics

Unless otherwise specified the following conditions apply: $V_{IN} = 13.5\text{ V}$, $f_{SW} = 400\text{ kHz}$, $L = 10\text{ }\mu\text{H}$, $C_{OUT_CSP} = 66\text{ }\mu\text{F}$, $C_{OUT_CSN} = 0.1\text{ }\mu\text{F}$, $C_{BUS} = 1\text{ }\mu\text{F}$, $T_A = 25\text{ }^\circ\text{C}$.

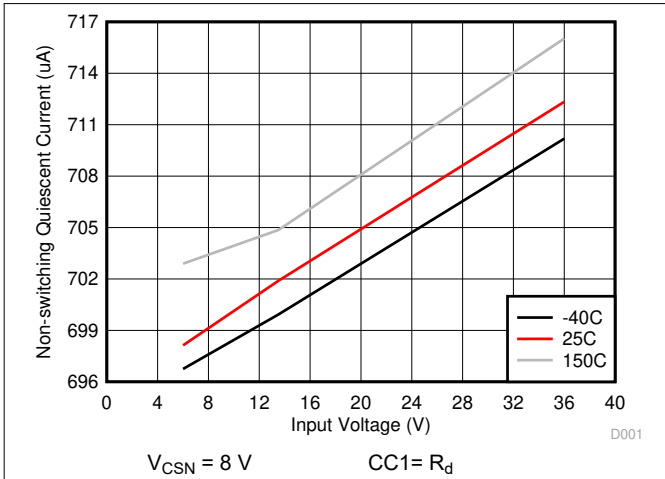

Figure 8-1. Non-Switching Quiescent Current

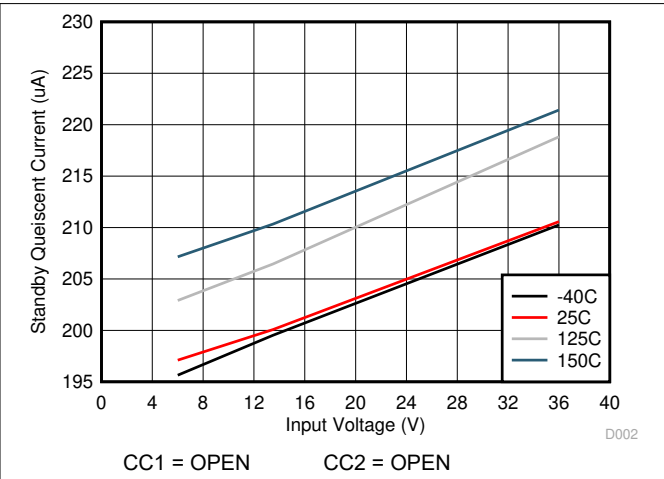

Figure 8-2. Standby Quiescent Current

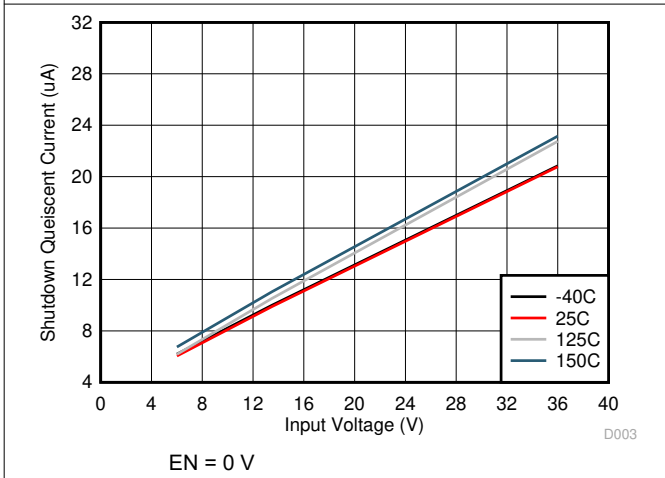

Figure 8-3. Shutdown Quiescent Current

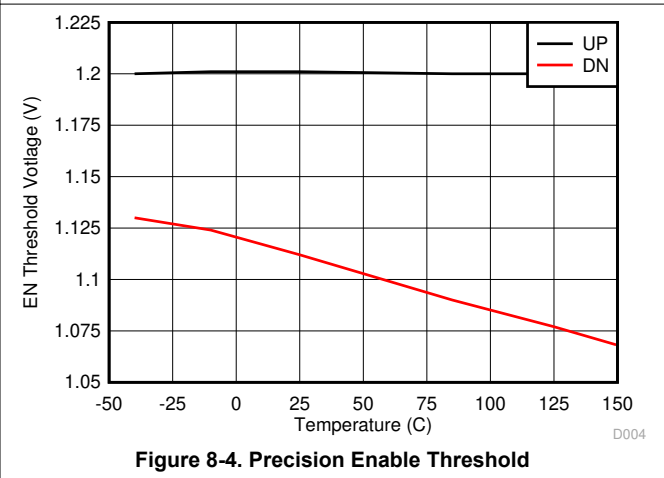

Figure 8-4. Precision Enable Threshold

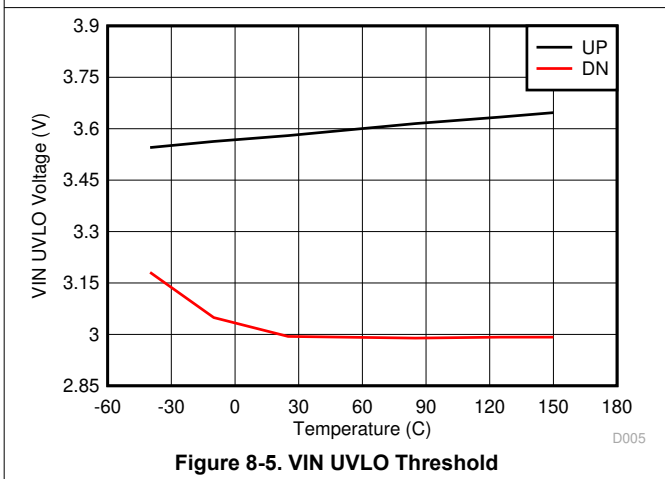

Figure 8-5. VIN UVLO Threshold

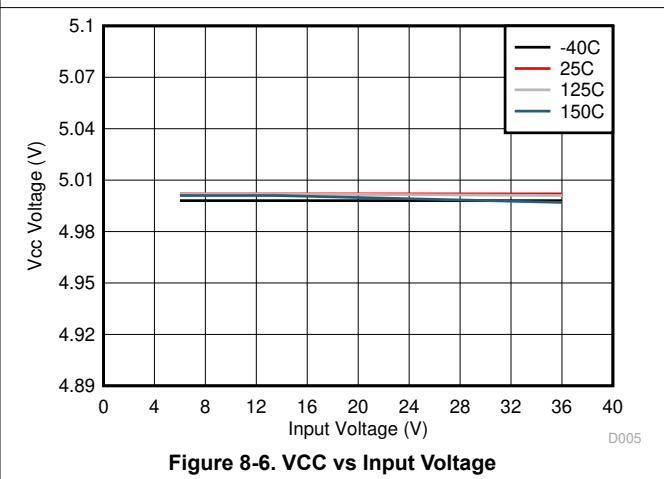

Figure 8-6. VCC vs Input Voltage

8.8 Typical Characteristics (continued)

Unless otherwise specified the following conditions apply: $V_{IN} = 13.5\text{ V}$, $f_{SW} = 400\text{ kHz}$, $L = 10\text{ }\mu\text{H}$, $C_{OUT_CSP} = 66\text{ }\mu\text{F}$, $C_{OUT_CSN} = 0.1\text{ }\mu\text{F}$, $C_{BUS} = 1\text{ }\mu\text{F}$, $T_A = 25\text{ }^\circ\text{C}$.

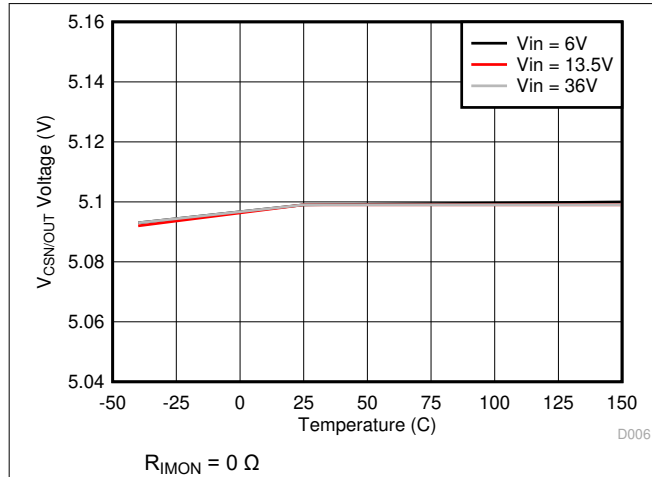

Figure 8-7. $V_{CSN/OUT}$ Voltage vs Junction Temperature

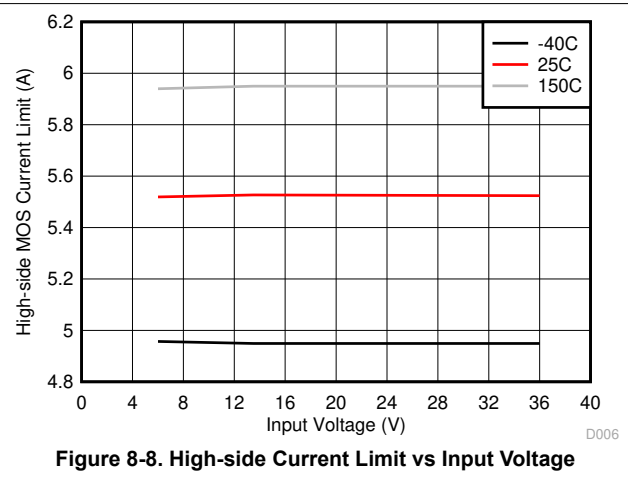

Figure 8-8. High-side Current Limit vs Input Voltage

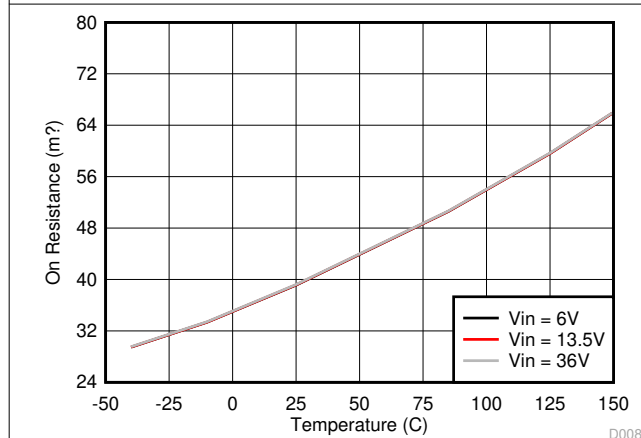

Figure 8-9. High-side MOSFET on Resistance vs Junction Temperature

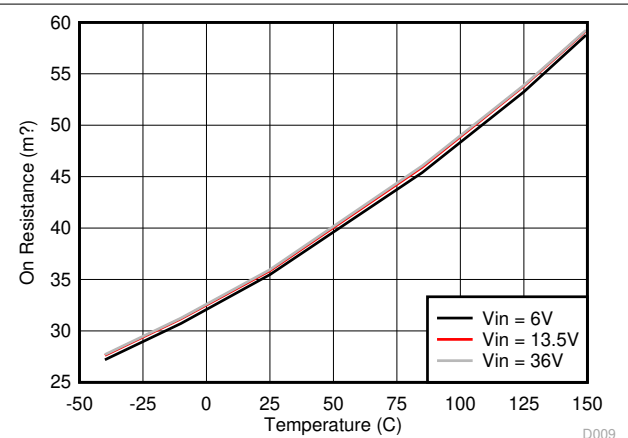

Figure 8-10. Low-side MOSFET on Resistance vs Junction Temperature

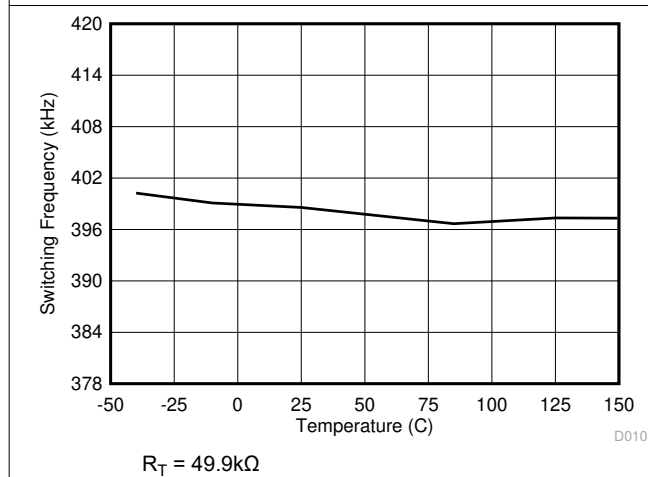

Figure 8-11. Switching Frequency vs Junction Temperature

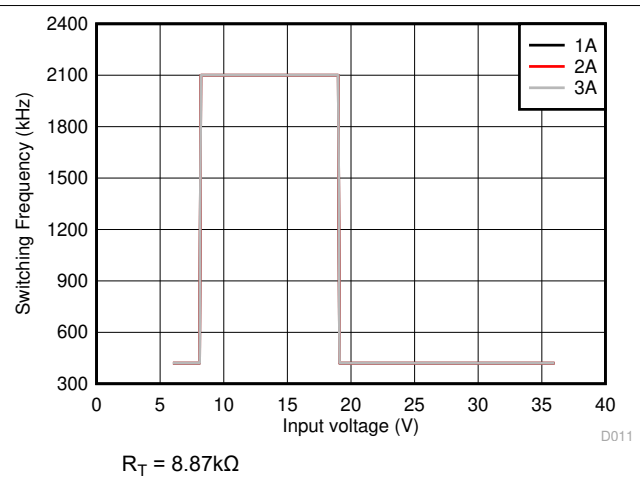
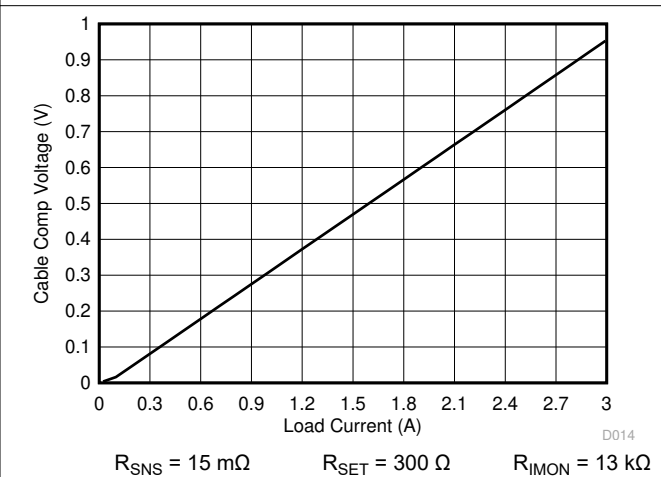
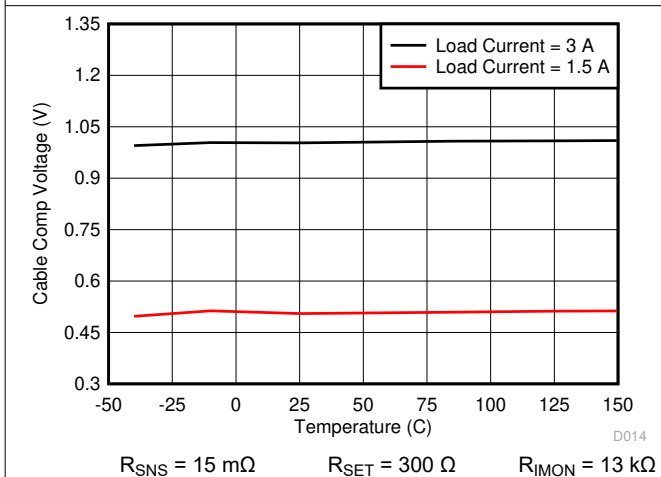
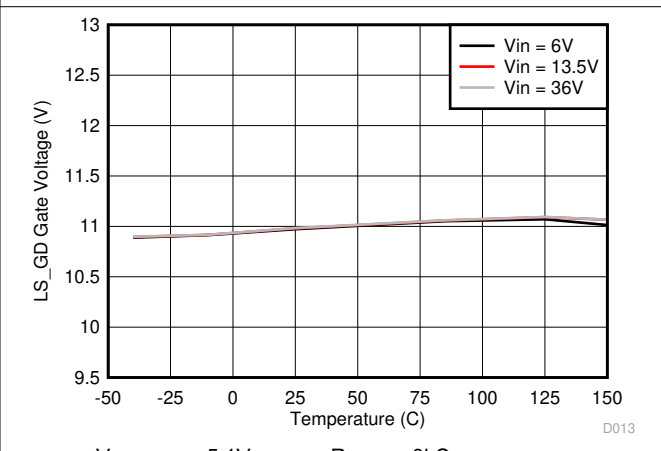
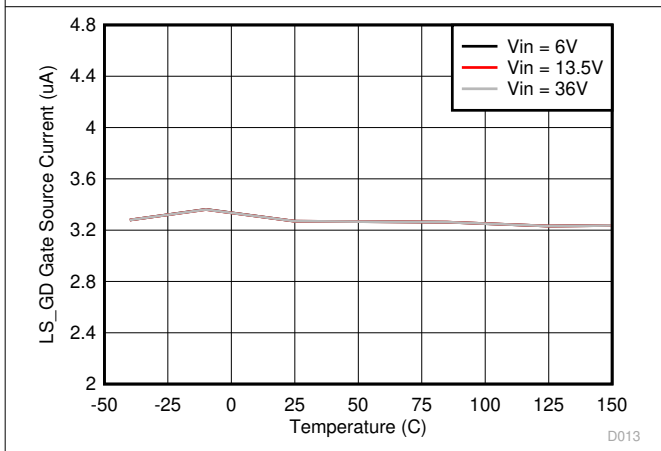
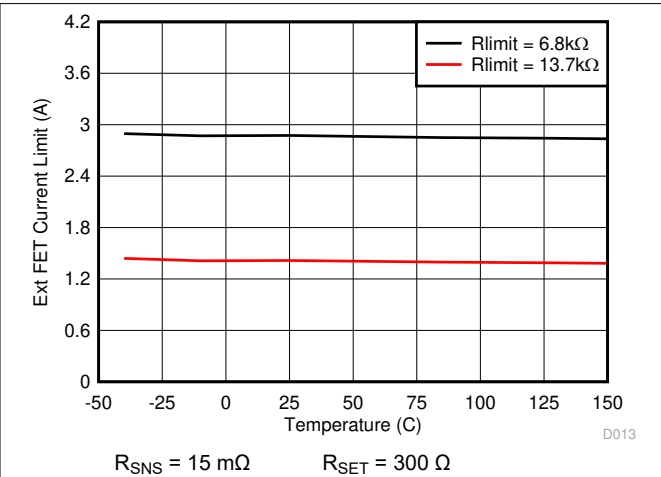
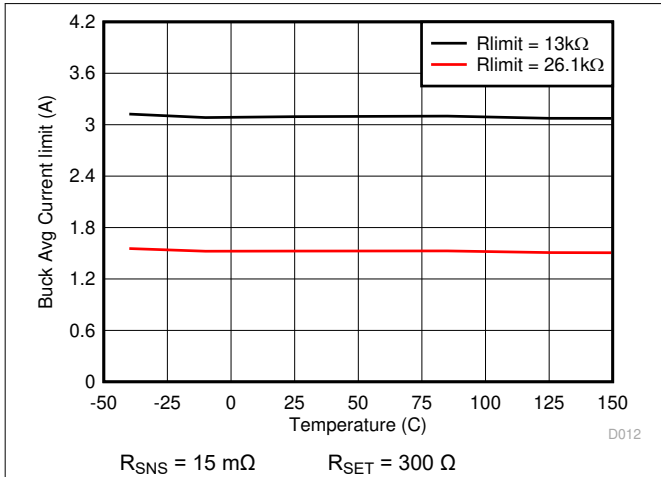

Figure 8-12. Switching Frequency vs VIN Voltage

8.8 Typical Characteristics (continued)

Unless otherwise specified the following conditions apply: $V_{IN} = 13.5\text{ V}$, $f_{SW} = 400\text{ kHz}$, $L = 10\text{ }\mu\text{H}$, $C_{OUT_CSP} = 66\text{ }\mu\text{F}$, $C_{OUT_CSN} = 0.1\text{ }\mu\text{F}$, $C_{BUS} = 1\text{ }\mu\text{F}$, $T_A = 25\text{ }^\circ\text{C}$.



8.8 Typical Characteristics (continued)

Unless otherwise specified the following conditions apply: $V_{IN} = 13.5\text{ V}$, $f_{SW} = 400\text{ kHz}$, $L = 10\text{ }\mu\text{H}$, $C_{OUT_CSP} = 66\text{ }\mu\text{F}$, $C_{OUT_CSN} = 0.1\text{ }\mu\text{F}$, $C_{BUS} = 1\text{ }\mu\text{F}$, $T_A = 25\text{ }^\circ\text{C}$.

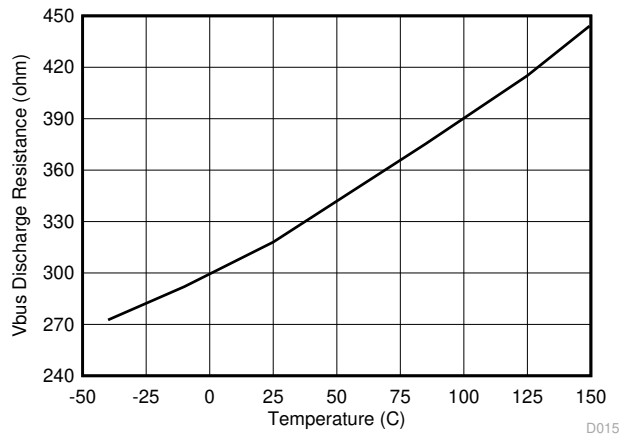

Figure 8-19. V_{BUS} Discharge Resistance vs Junction Temperature

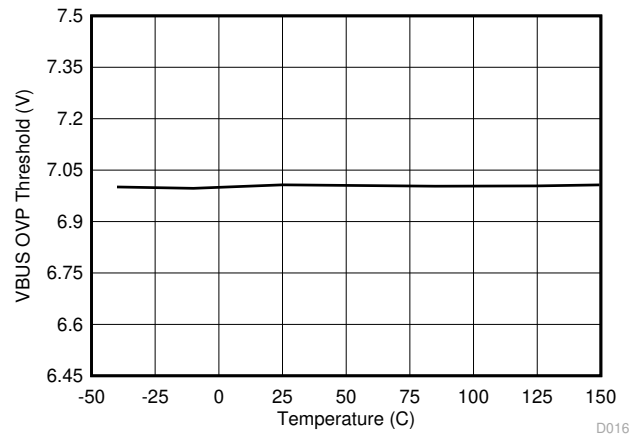

Figure 8-20. V_{BUS} Overvoltage Protection Threshold vs Junction Temperature

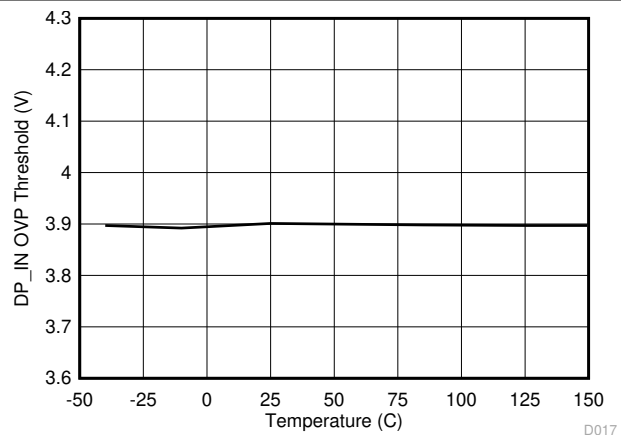

Figure 8-21. DP_IN Overvoltage Protection Threshold vs Junction Temperature

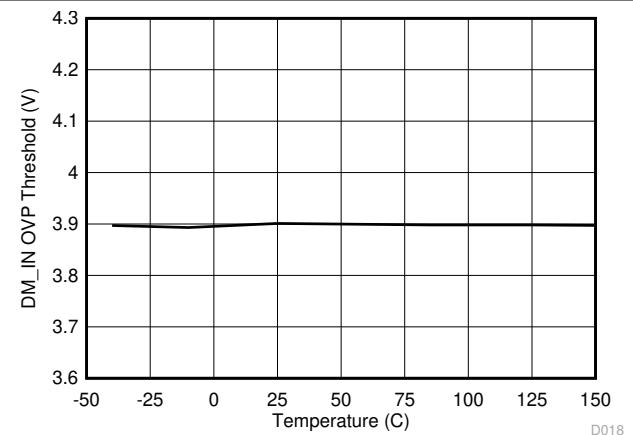

Figure 8-22. DM_IN Overvoltage Protection Threshold vs Junction Temperature

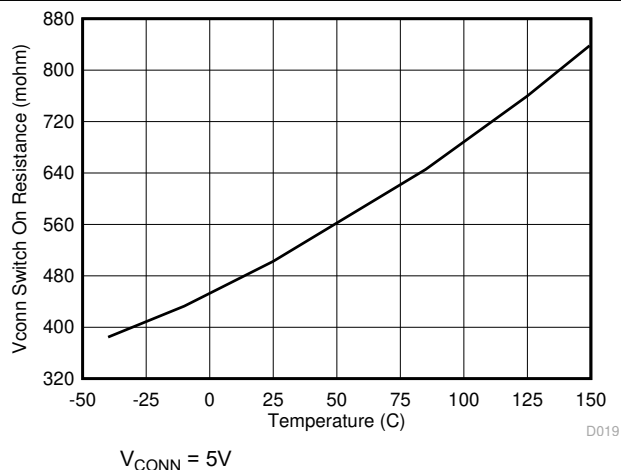

Figure 8-23. V_{CONN} Current Limiting Switch On Resistance vs Junction Temperature

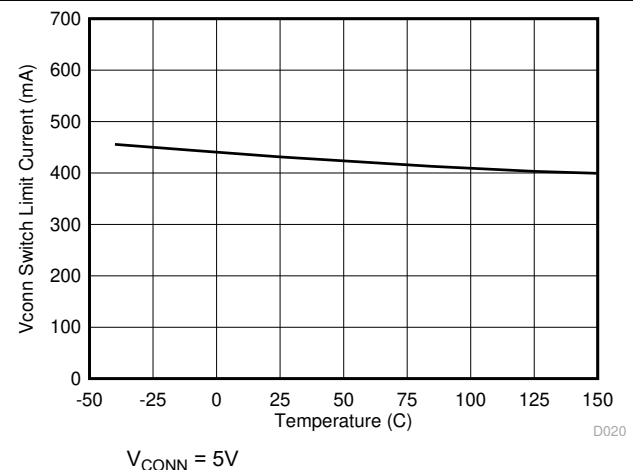

Figure 8-24. V_{CONN} Switch Current Limit vs Junction Temperature

8.8 Typical Characteristics (continued)

Unless otherwise specified the following conditions apply: $V_{IN} = 13.5\text{ V}$, $f_{SW} = 400\text{ kHz}$, $L = 10\text{ }\mu\text{H}$, $C_{OUT_CSP} = 66\text{ }\mu\text{F}$, $C_{OUT_CSN} = 0.1\text{ }\mu\text{F}$, $C_{BUS} = 1\text{ }\mu\text{F}$, $T_A = 25\text{ }^\circ\text{C}$.

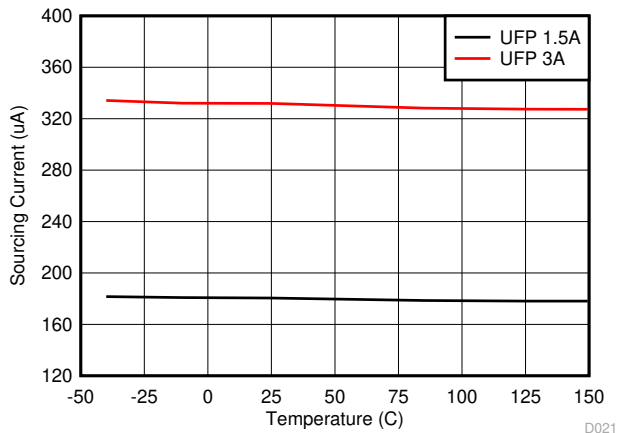

Figure 8-25. CC Sourcing Current vs Junction Temperature

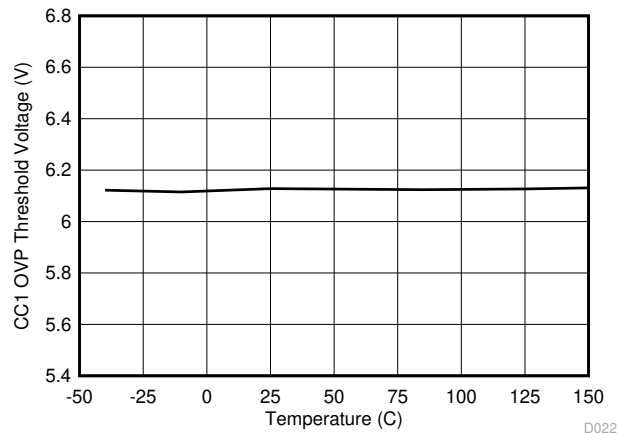

Figure 8-26. CC1 Overvoltage Protection Threshold vs Junction Temperature

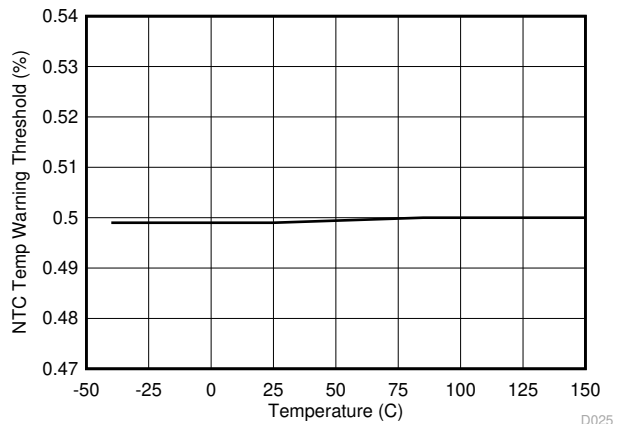

Figure 8-27. NTC Temperature Warning Threshold (TPS25831-Q1)

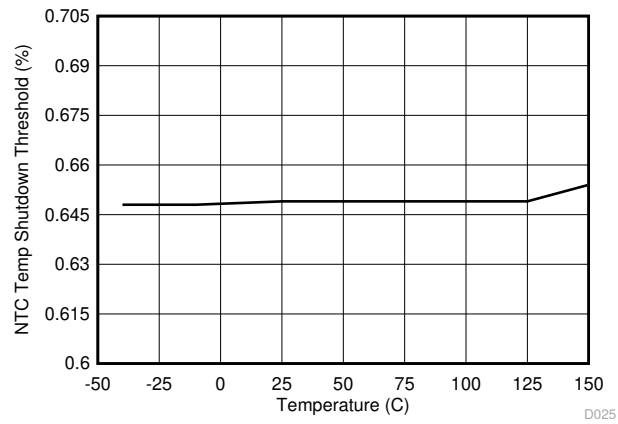
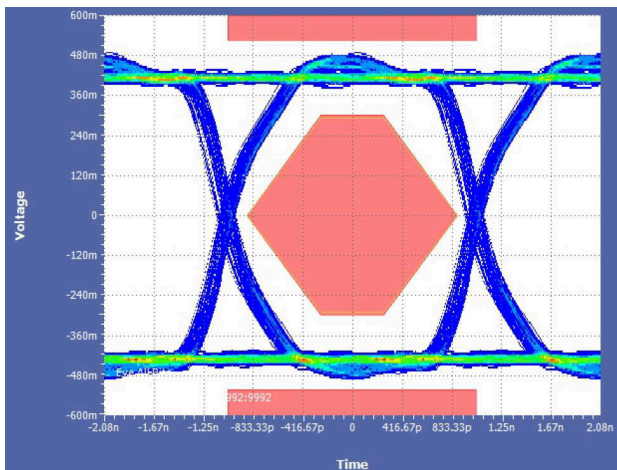
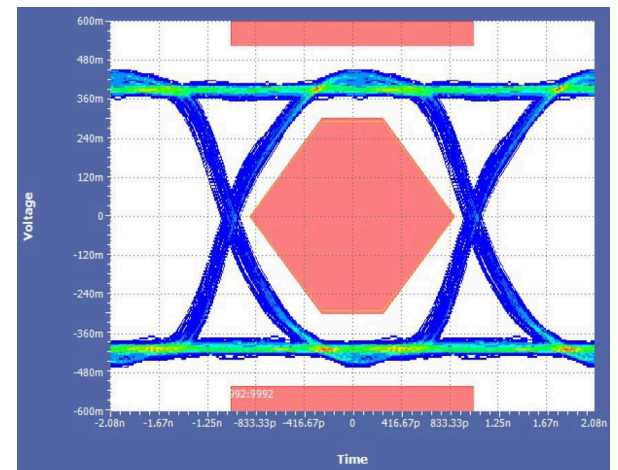

Figure 8-28. NTC Temperature Shutdown Threshold (TPS25831-Q1)



Measured Source with 10-cm cable

Figure 8-29. Bypassing the TPS25830-Q1 Data Switch



Measured on TPS25830-Q1 EVM with 10-cm cable

Figure 8-30. Through the TPS25830-Q1 Data Switch

8.8 Typical Characteristics (continued)

Unless otherwise specified the following conditions apply: $V_{IN} = 13.5\text{ V}$, $f_{SW} = 400\text{ kHz}$, $L = 10\text{ }\mu\text{H}$, $C_{OUT_CSP} = 66\text{ }\mu\text{F}$, $C_{OUT_CSN} = 0.1\text{ }\mu\text{F}$, $C_{BUS} = 1\text{ }\mu\text{F}$, $T_A = 25\text{ }^\circ\text{C}$.

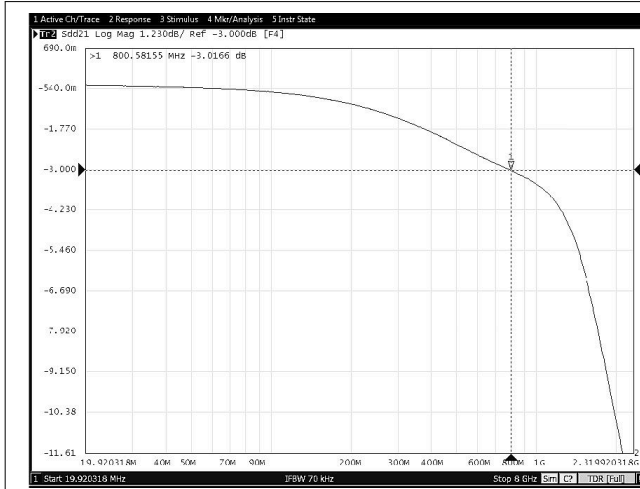

Figure 8-31. Data Transmission Characteristics vs Frequency (TPS25830-Q1)



Figure 8-32. Off-State Data-Switch Isolation vs Frequency (TPS25830-Q1)

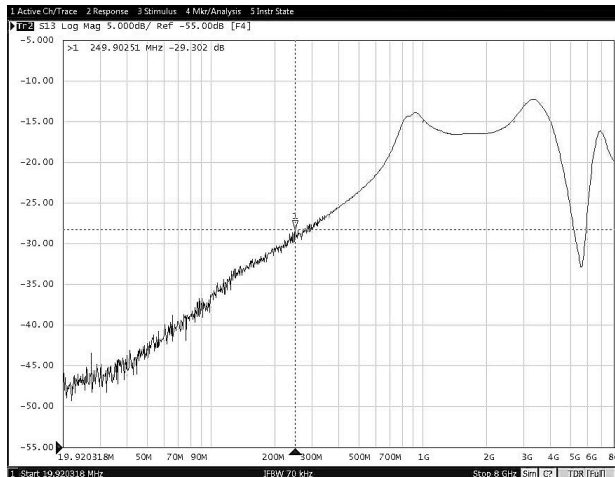

Figure 8-33. On-State Cross-Channel Isolation vs Frequency (TPS25830-Q1)

9 Parameter Measurement Information

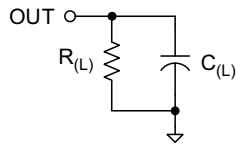

Figure 9-1. V_{CONN} Switch Rise-Fall Test Load Figure

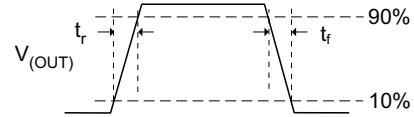

Figure 9-2. V_{CONN} Switch Rise-Fall Timing

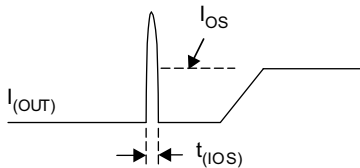

Figure 9-3. Short-Circuit Parameters

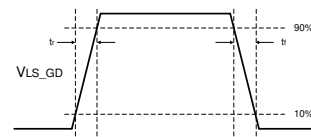

Figure 9-4. NFET Gate Drive Rise and Fall Time

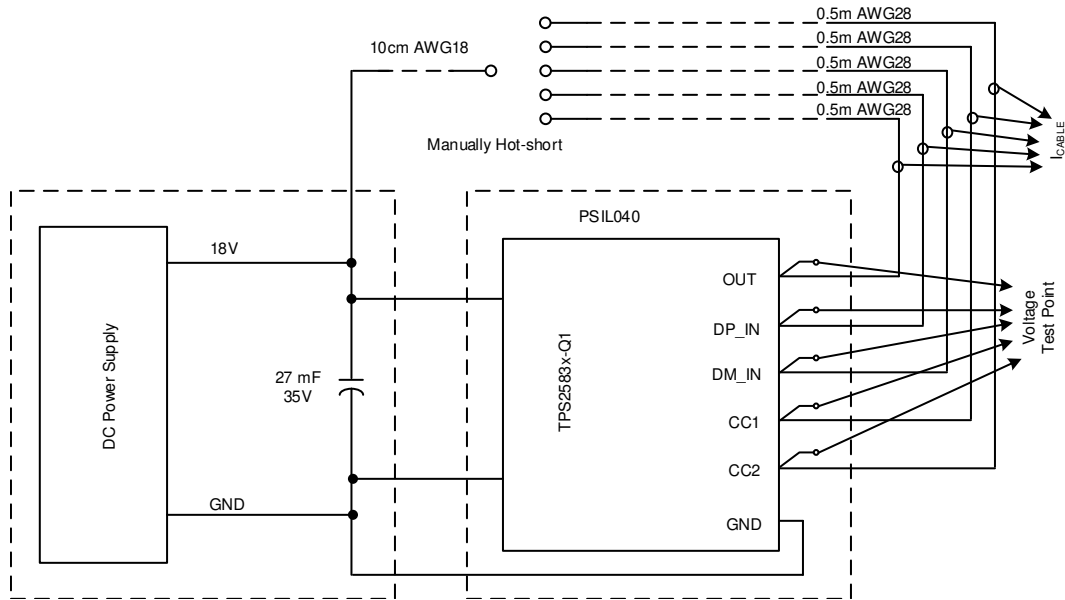

Figure 9-5. Short-to-Battery System Test Setup

10 Detailed Description

10.1 Overview

The TPS25830-Q1 and TPS25831-Q1 are full-featured solutions for implementing a compact USB charging port with support for both Type-C and BC1.2 standards. Both devices contain an efficient 36-V buck regulator power source capable of providing up to 3.5 A of output current at 5.10 V (nominal). System designers can optimize efficiency or solution size through careful selection of switching frequency over the range of 300 to 2200 kHz with sufficient margin to operate above or below the AM radio frequency band. In devices, the buck regulator operates in forced PWM mode ensuring fixed switching frequency regardless of load current. Spread-spectrum frequency dithering reduces harmonic peaks of the switching frequency potentially simplifying EMI filter design and easing compliance.

Current sensing with a precision high-side current sense amplifier enables an accurate, user programmable overcurrent limit setting; and programmable linear cable compensation to overcome IR losses when powering remote USB ports.

The TPS25830-Q1 integrates high band-width (800 MHz) USB switches and includes short-to- V_{BAT} and short-to- V_{BUS} protection as well as IEC61000-4-2 electrostatic discharge clamps to protect the host from potentially damaging overvoltage conditions. The CTRL1 and CTRL2 pins set the operating mode for the TPS25830-Q1 implementing Type-C, CDP and SDP USB port configurations.

The TPS25831-Q1 includes an NTC input and $\overline{THERM_WARN}$ flag for user programmable thermal protection using a negative temperature coefficient resistor. The CTRL1 and CTRL2 pins set the operating mode for the TPS25831-Q1, implementing Type-C, DCP, CDP and SDP USB ports.

10.2 Functional Block Diagram

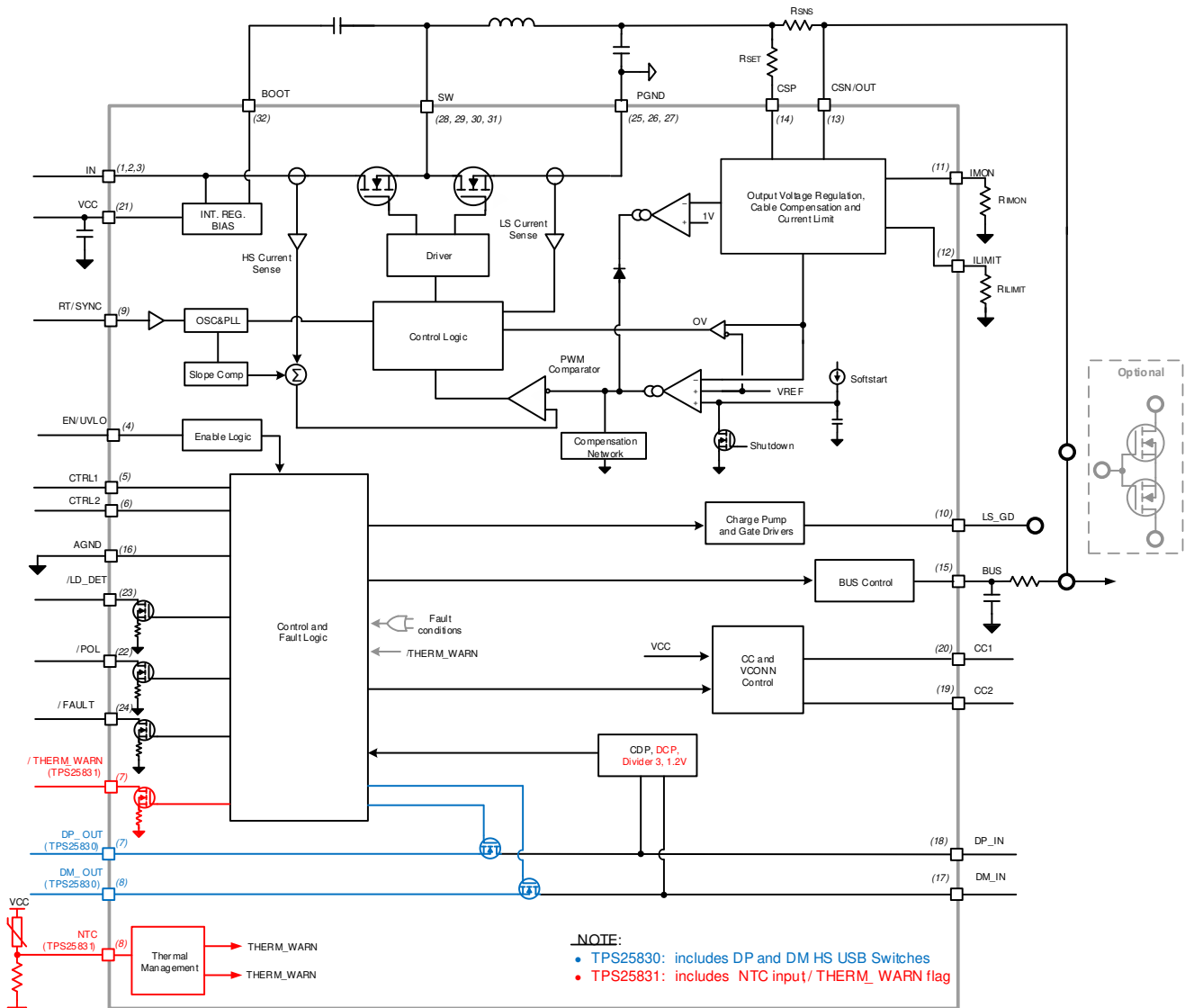

10.3 Feature Description

10.3.1 Buck Regulator

The following operating description of the TPS25830-Q1, TPS25831-Q1 will refer to the *Functional Block Diagram* and to the waveforms in *Figure 10-1*. TPS2583x-Q1 is a step-down synchronous buck regulator with integrated high-side (HS) and low-side (LS) switches (synchronous rectifier). The TPS2583x-Q1 supplies a regulated output voltage by turning on the HS and LS NMOS switches with controlled duty cycle. During high-side switch ON time, the SW pin voltage swings up to approximately V_{IN} , and the inductor current i_L increase with linear slope $(V_{IN} - V_{OUT}) / L$. When the HS switch is turned off by the control logic, the LS switch is turned on after an anti-shoot-through dead time. Inductor current discharges through the LS switch with a slope of $-V_{OUT} / L$. The control parameter of a buck converter is defined as Duty Cycle $D = t_{ON} / T_{SW}$, where t_{ON} is the high-side switch ON time and T_{SW} is the switching period. The regulator control loop maintains a constant output voltage by adjusting the duty cycle D . In an ideal buck converter, where losses are ignored, D is proportional to the output voltage and inversely proportional to the input voltage: $D = V_{OUT} / V_{IN}$.

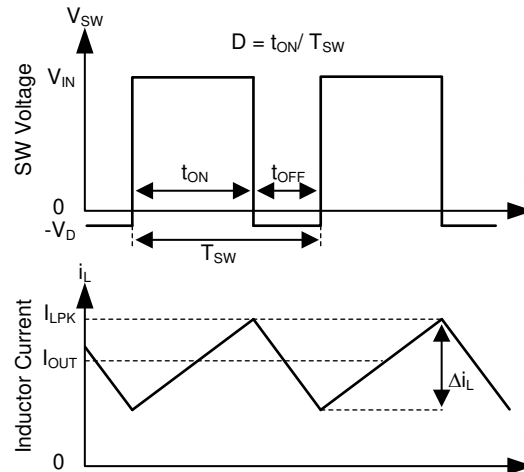

Figure 10-1. SW Node and Inductor Current Waveforms in Continuous Conduction Mode (CCM)

The TPS2583x-Q1 employs fixed frequency peak current mode control. A voltage feedback loop is used to get accurate DC voltage regulation by adjusting the peak current command based on voltage offset. The peak inductor current is sensed from the high-side switch and compared to the peak current threshold to control the ON time of the high-side switch. The voltage feedback loop is internally compensated, which allows for fewer external components, makes it easy to design, and provides stable operation with a reasonable combination of output capacitors. TPS2583x-Q1 operates in FPWM mode for low output voltage ripple, tight output voltage regulation, and constant switching frequency.

10.3.2 Enable/UVLO and Start-up

The voltage on the EN/UVLO pin controls the ON or OFF operation of TPS2583x-Q1. An EN/UVLO pin voltage higher than $V_{EN/UVLO-H}$ is required to start the internal regulator and begin monitoring the CCn lines for a valid Type-C connection. The internal USB monitoring circuitry is on when V_{IN} is within the operation range and the EN/UVLO threshold is cleared; however, the buck regulator does not begin operation until a valid USB Type-C detection has been made. This feature ensures the "cold socket" (0 V) USB Type-C V_{BUS} requirement is met. The EN/UVLO pin is an input and cannot be left open or floating. The simplest way to enable the operation of the TPS2583x-Q1 is to connect the EN to V_{IN} . This connection allows self-start-up of the TPS2583x-Q1 when V_{IN} is within the operation range.

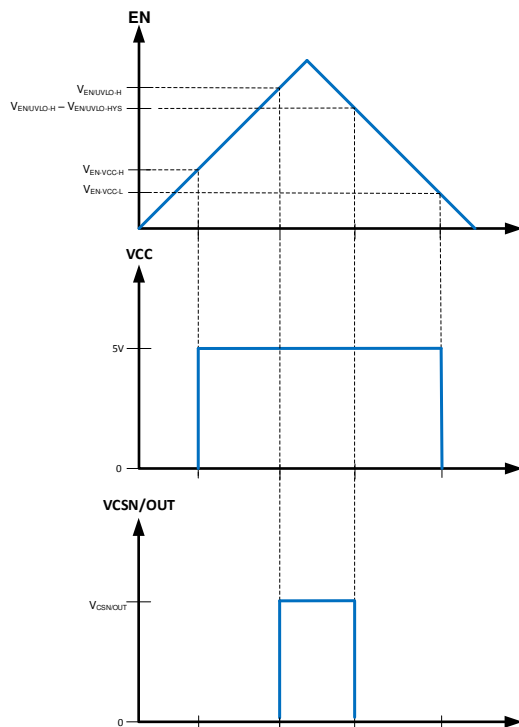

Figure 10-2. Precision Enable Behavior

Many applications will benefit from the employment of an enable divider, R_{ENT} and R_{ENB} , (Figure 10-3) to establish a precision system UVLO level for the TPS2583x-Q1. The system UVLO can be used for sequencing, ensuring reliable operation, or supply protection, such as a battery discharge level. To ensure the USB port V_{BUS} is within the 5-V operating range as required for USB compliance (for the latest USB specifications and requirements, refer to USB.org), TI suggests that the R_{ENT} and R_{ENB} resistors be chosen so that the TPS2583x-Q1 enables when V_{IN} is approximately 6 V. Considering the drop out voltage of the buck regulator and IR losses in the system, 6 V provides adequate margin to maintain V_{BUS} within USB specifications. If system requirements such as a warm crank (start) automotive scenario require operation with $V_{IN} < 6$ V, the values of R_{ENT} and R_{ENB} can be calculated assuming a lower V_{IN} . An external logic signal can also be used to drive EN/UVLO input when a microcontroller is present and it is desirable to enable or disable the USB port remotely for other reasons.

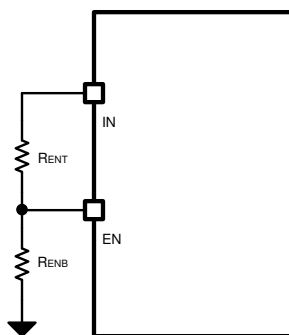

Figure 10-3. System UVLO by Enable Divider

UVLO configuration using external resistors is governed by the following equations:

$$R_{ENT} = \left(\frac{V_{IN(ON)}}{V_{EN/UVLO_H}} - 1 \right) \times R_{ENB} \quad (1)$$

$$V_{IN(OFF)} = V_{IN(ON)} \times \left(1 - \frac{V_{EN/UVLO_HYS}}{V_{EN/UVLO_H}} \right) \quad (2)$$

Example:

$V_{IN(ON)} = 6 \text{ V}$ (user choice)

$R_{ENB} = 5 \text{ k}\Omega$ (user choice)

$R_{ENT} = [(V_{IN(ON)} / V_{EN/UVLO_H}) - 1] \times R_{ENB} = 19.6 \text{ k}\Omega$. Choose standard 20 k Ω .

Therefore $V_{IN(OFF)} = 6 \text{ V} \times [1 - (0.09 \text{ V} / 1.2 \text{ V})] = 5.55 \text{ V}$

Figure 10-4 shows a typical start-up waveform, indicating typical timings when R_d connected to CC line. The rise time of DCDC VBUS voltage is about 5 ms.

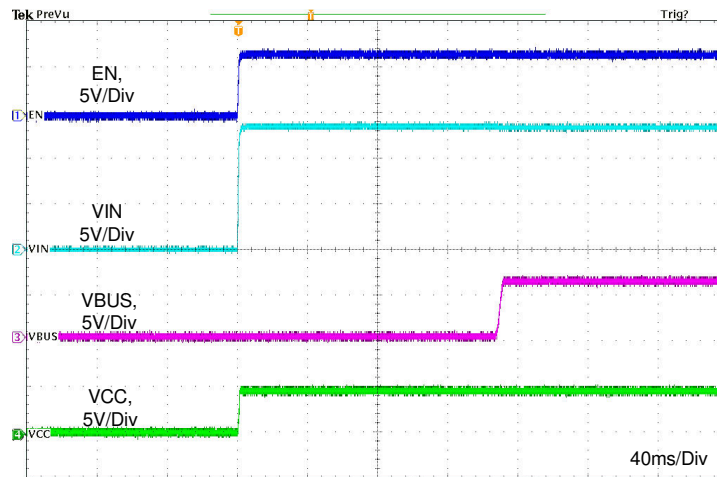

Figure 10-4. Typical Start-up Behavior, $V_{IN} = 13.5 \text{ V}$, $CC1 = R_d$, $R_{IMON} = 12.6 \text{ k}\Omega$

For TPS25830-Q1, the pin voltage must meet the requirement below during 150 ms (typical) R_d assert deglitch time. See Figure 10-5:

- $V_{BUS} < 0.8 \text{ V}$ (typical), per Type-C requirement
- $V_{DX_OUT} < 2.2 \text{ V}$ (typical)
- $V_{DX_IN} < 1.5 \text{ V}$ (typical)

After the TPS25830-Q1 R_d assert deglitch time, there is no additional requirement on these pins. In real application, $\overline{LD_DET}$ pin can be used to configure the timing sequence.

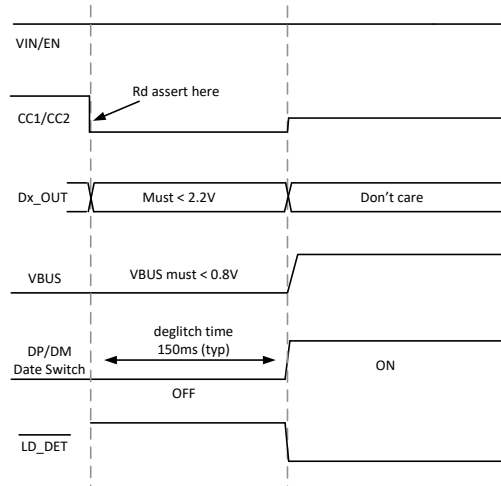

Figure 10-5. TPS25830-Q1 Pin Voltage Requirement During Rd Assert

10.3.3 Switching Frequency and Synchronization (RT/SYNC)

The switching frequency of the TPS2583x-Q1 can be programmed by the resistor, R_T , from the RT/SYNC pin and GND pin. Use Equation 3 to determine the R_T resistance, for a given switching frequency:

$$R_{\text{FREQ}} (\text{k}\Omega) = 26660 \times f_{\text{SW}}^{-1.0483} (\text{kHz}) \quad (3)$$

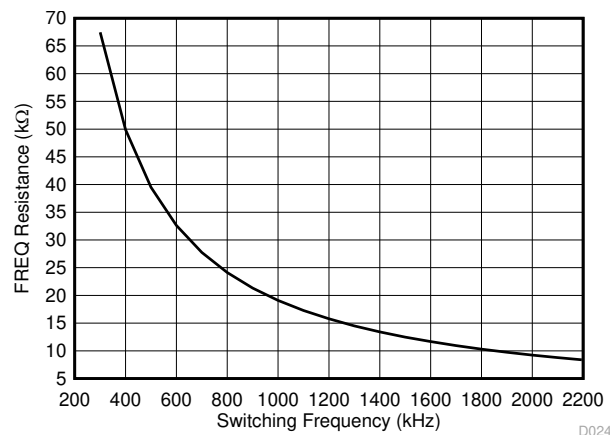

Figure 10-6. RT Set Resistor vs Switching Frequency

Table 10-1 lists typical R_T resistors value.

Table 10-1. Setting the Switching Frequency with R_T

RT (kΩ)	SWITCHING FREQUENCY (kHz)
68.1	300
49.9	400
39.2	500
19.1	1000
12.4	1500
9.31	2000
8.87	2100
8.45	2200

TPS2583x-Q1 switching action can be synchronized to an external clock from 300 kHz to 2.3 MHz. The

RT/SYNC pin can be used to synchronize the internal oscillator to an external clock. The internal oscillator can be synchronized by AC coupling a positive edge into the RT/SYNC pin. The AC coupled peak-to-peak voltage at the RT/SYNC pin must exceed the SYNC amplitude threshold of 3.5 V (typical) to trip the internal synchronization pulse detector, and the minimum SYNC clock ON and OFF time must be longer than 100 ns (typical). When using a low impedance signal source, the frequency setting resistor, R_T , is connected in parallel with an AC coupling capacitor, C_{COUP} , to a termination resistor, R_{TERM} , (for example, 50 Ω). The two resistors in series provide the default frequency setting resistance when the signal source is turned off. A 10-pF ceramic capacitor can be used for C_{COUP} . Figure 10-7 shows the device synchronized to an external clock.

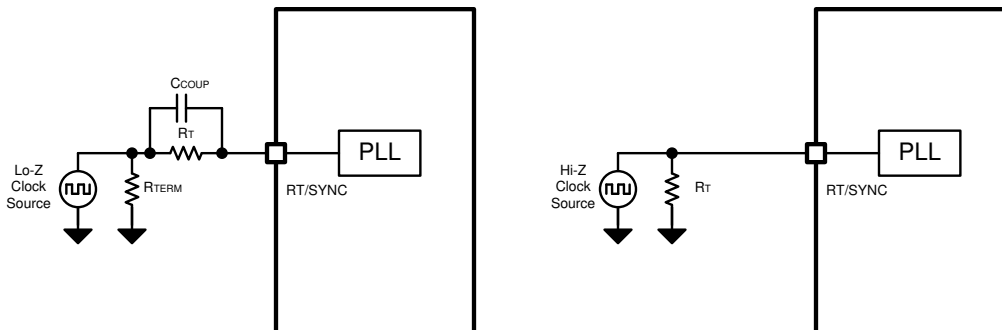

Figure 10-7. Synchronize to External Clock

In order to avoid AM radio frequency band and maintain proper regulation when minimum ON-time or minimum OFF-time is reached, the TPS2583x-Q1 implement frequency foldback scheme depends on V_{IN} voltage,. Refer to Figure 8-11.

- When $8\text{ V} < V_{IN} \leq 19\text{ V}$, the switching frequency of TPS2583x-Q1 is determined by R_T resistor or external sync clock.
- When $V_{IN} \leq 8\text{ V}$, the switching frequency of TPS2583x-Q1 is set to default 420 kHz, regardless of R_T resistor setting or external sync clock.
- When $V_{IN} > 19\text{ V}$, the switching frequency of TPS2583x-Q1 is set to default 420 kHz, regardless of R_T resistor setting or external sync clock

Figure 10-8, Figure 10-9 and Figure 10-10 show the device switching frequency and behavior under different V_{IN} voltage and $R_T = 8.87\text{ k}\Omega$.

Figure 10-11, Figure 10-12 and Figure 10-13 show the device switching frequency and behavior under different V_{IN} voltage and synchronized to an external 2.1-M system clock.

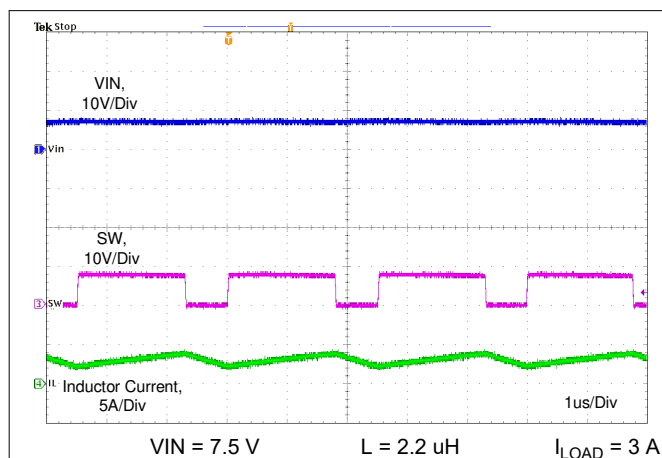

Figure 10-8. Switching Frequency When $R_T = 8.87\text{ k}\Omega$

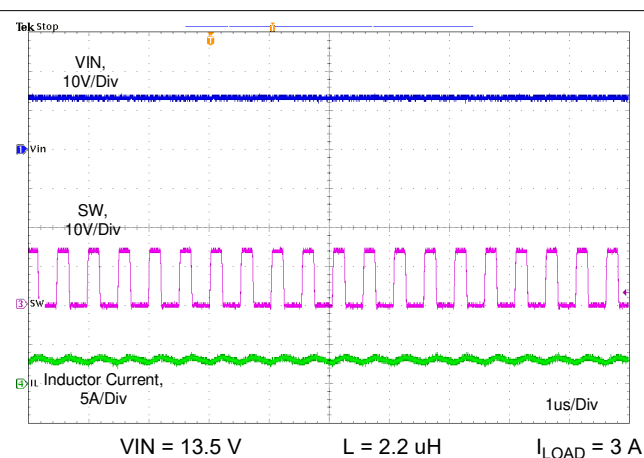

Figure 10-9. Switching Frequency When $R_T = 8.87\text{ k}\Omega$

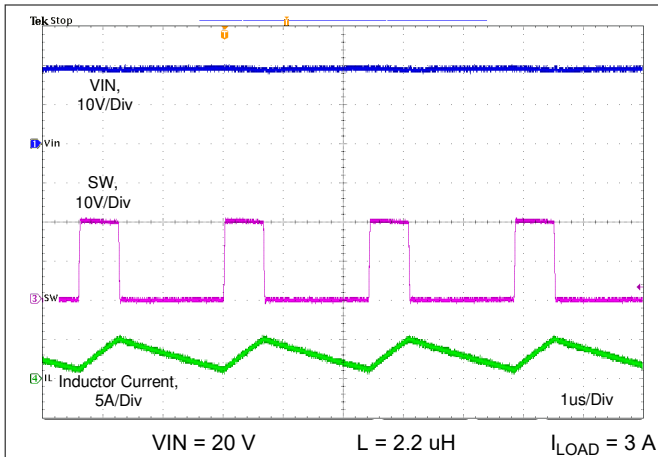

Figure 10-10. Switching Frequency When $R_T = 8.87 \text{ k}\Omega$

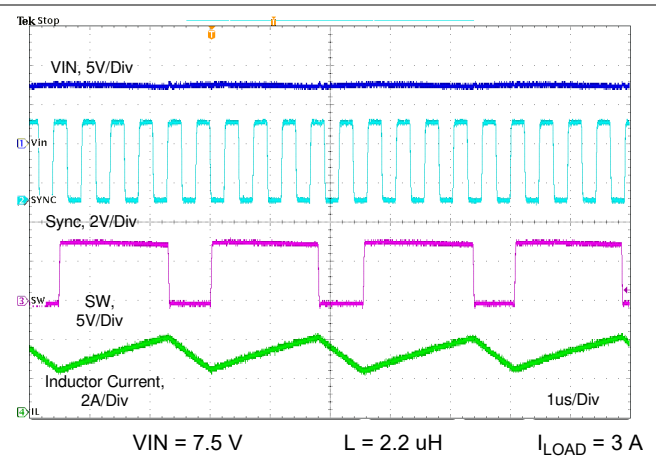

Figure 10-11. Synchronizing to External 2.1-MHz Clock

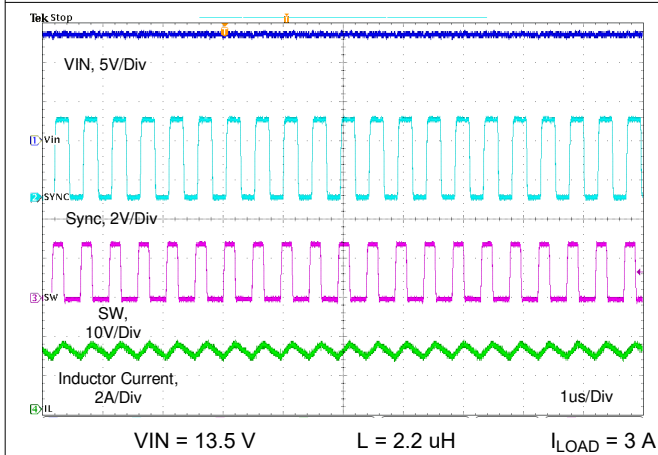

Figure 10-12. Synchronizing to External 2.1-MHz Clock

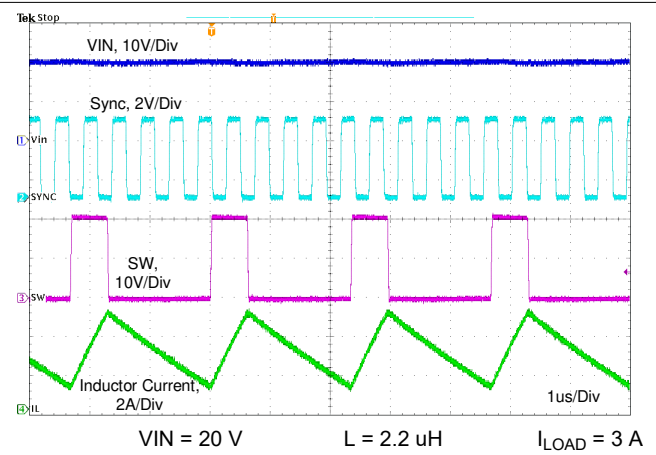

Figure 10-13. Synchronizing to External 2.1-MHz Clock

10.3.4 Spread-Spectrum Operation

In order to reduce EMI, the TPS2583x-Q1 introduce frequency spread spectrum. The spread spectrum is used to eliminate peak emissions at specific frequencies by spreading emissions across a wider range of frequencies than a part with fixed frequency operation. In most systems, low frequency conducted emissions from the first few harmonics of the switching frequency can be easily filtered. A more difficult design criterion is reduction of emissions at higher harmonics which fall in the FM band. These harmonics often couple to the environment through electric fields around the switch node. The TPS2583x-Q1 devices use $\pm 6\%$ spread of switching frequencies with 1/256 swing frequency.

The spread spectrum function is only available when using the TPS2583x-Q1 internal oscillator. If the RT/SYNC pin is synchronized to an external clock, the spread spectrum function will be turned off.

10.3.5 VCC, VCC_UVLO

The TPS2583x-Q1 integrates an internal LDO to generate V_{CC} for control circuitry and MOSFET drivers. The nominal voltage for V_{CC} is 5 V. The V_{CC} pin is the output of an LDO and must be properly bypassed. A high quality ceramic capacitor with a value of 2.2 μF to 4.7 μF , 10 V or higher rated voltage should be placed as close as possible to VCC and grounded to the PGND ground pin. The V_{CC} output pin should not be loaded with more than 5 mA, or shorted to ground during operation.

In applications where V_{CONN} support is required, the V_{CC} pin can be over-driven with an external 5-V LDO capable of sourcing at least 300 mA. In this operating mode the external LDO is the source for the buck low-side switch gate drive as well as power to the internal V_{CONN} mux.

Note if using external 5-V LDO for V_{CONN} power, the timing sequence below must be required. External V_{CONN} power can not be enabled before the TPS2583x-Q1 is enabled, external V_{CONN} must be disabled before the TPS2583x-Q1 is disabled. In real application, customer can tie the EN of external 5-V LDO and EN of TPS2583x-Q1 together to meet the timing requirement.

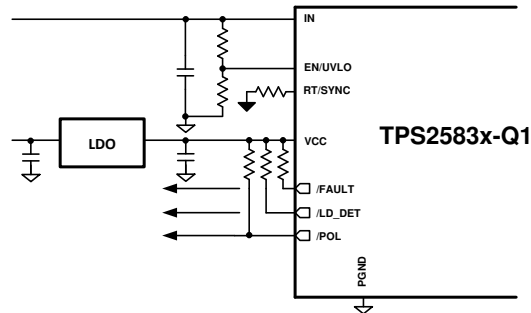

Figure 10-14. V_{CONN} Source Using External LDO

10.3.6 Minimum ON-time, Minimum OFF-time

Minimum ON-time, T_{ON_MIN} , is the smallest duration of time that the HS switch can be on. T_{ON_MIN} is typically 105 ns in the TPS2583x. Minimum OFF-time, T_{OFF_MIN} , is the smallest duration that the HS switch can be off. T_{OFF_MIN} is typically 80 ns in the TPS2583x-Q1. In CCM (FPWM) operation, T_{ON_MIN} and T_{OFF_MIN} limit the voltage conversion range given a selected switching frequency.

The minimum duty cycle allowed is:

$$D_{MIN} = T_{ON_MIN} \times f_{sw} \quad (4)$$

And the maximum duty cycle allowed is:

$$D_{MAX} = 1 - T_{OFF_MIN} \times f_{sw} \quad (5)$$

Given fixed T_{ON_MIN} and T_{OFF_MIN} , the higher the switching frequency the narrower the range of the allowed duty cycle.

10.3.7 Internal Compensation

The TPS2583x-Q1 is internally compensated as shown in Figure 10-1. The internal compensation is designed such that the loop response is stable over the specified operating frequency and output voltage range. The TPS2583x-Q1 is optimized for transient response over the range $300 \text{ kHz} \leq f_{sw} \leq 2300 \text{ kHz}$.

10.3.8 Bootstrap Voltage (BOOT)

The TPS2583x-Q1 provides an integrated bootstrap voltage regulator. A small capacitor between the BOOT and SW pins provides the gate drive voltage for the high-side MOSFET. The BOOT capacitor is refreshed when the high-side MOSFET is off and the low-side switch conducts. The recommended value of the BOOT capacitor is 0.1 μF . A ceramic capacitor with an X7R or X5R grade dielectric with a voltage rating of 10 V or higher is recommended for stable performance over temperature and voltage.

10.3.9 R_{SNS} , R_{SET} , R_{LIMIT} and R_{IMON}

The programmable current limit threshold and full-scale cable compensation voltage are determined by the values of the R_{SNS} , R_{SET} , R_{LIMIT} , and R_{IMON} resistors. Refer to Figure 10-15.

- R_{SNS} is the current sense resistor. The recommended voltage across R_{SNS} under current limit should be approximately 50 mV as a compromise between accuracy and power dissipation. For example, if current limiting is desired for $I_{OUT(MAX)} \geq 3.3$ A, then $R_{SNS} = 0.05 \text{ V} / 3.3 \text{ A} = 0.01515 \Omega$. Choose a standard value of 15 m Ω .
- R_{SET} determines the input current to the transconductance amplifier and current mirror. The amplifier balances the voltage to be equal to that across R_{SNS} . Choose a R_{SET} value to produce an I_{SET} current from 75 - 180 μA at the desired $I_{OUT(MAX)}$. Considering 50 mV across R_{SET} , a value of 300 Ω will provide approximately 166 μA of I_{SET} current to the amplifier and mirror circuit. Care should be taken to limit the I_{SET} current below 200 μA to avoid saturating the internal amplifier circuit.
- R_{LIMIT} in conjunction with the $0.5 \times I_{SET}$ current produces a voltage on the ILIMIT pin which is proportional to the load current flowing in R_{SNS} . For details on setting the current limit, see [Current Limit Setting using \$R_{LIMIT}\$](#) .
- R_{IMON} in conjunction with the $0.5 \times I_{SET}$ current produces a voltage on the IMON pin which is proportional to the load current flowing in R_{SNS} . For details on setting the current limit. see [Cable Compensation](#).

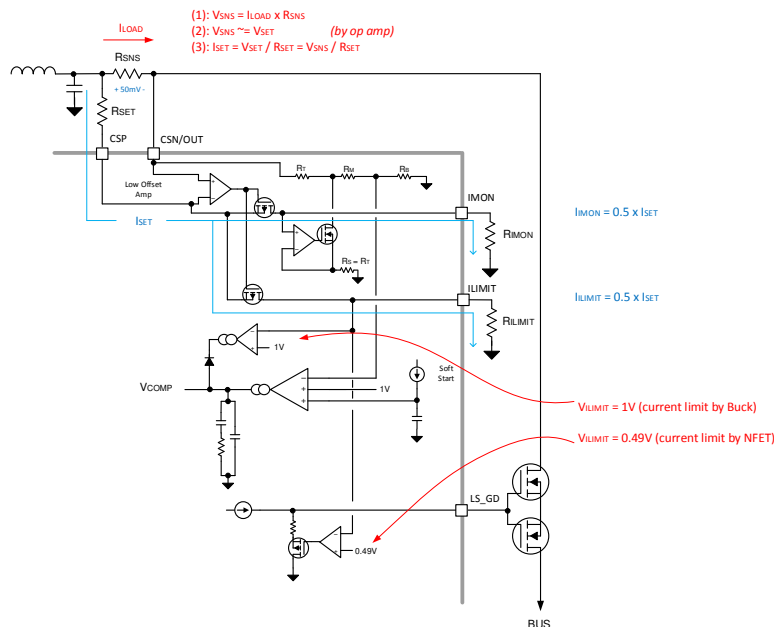

Figure 10-15. Current Limit and Cable Compensation Circuit

10.3.10 Overcurrent and Short Circuit Protection

For maximum versatility, TPS2583x-Q1 includes both a precision, programmable current limit and cycle-by-cycle current limit to protect the USB port from extreme overload conditions. In most applications the R_{LIMIT} resistor in conjunction with the selection of R_{SNS} and R_{SET} will determine the overload threshold. The cycle-by-cycle current limit will serve as a backup means of protection in the event R_{LIMIT} is shorted to ground disabling the programmable current limit function.

In some application, the setting of TPS2583x-Q1 over-current need meet MFi requirement. For more details please refer to [How to Pass MFi Overcurrent Protection Test With USB Charger and Switch Device application report](#).

10.3.10.1 Current Limit Setting using R_{LIMIT}

Refer to [Figure 10-15](#). The TPS2583x-Q1 can establish current limit by two methods.

- Using external a single or back-to-back N-Channel MOFETs between CSN/OUT and BUS: A voltage of 0.49 V on the ILIMIT pin initiates current limiting using the external MOSFET by decreasing the LS_GD voltage causing the FET to operate in the saturation region. To protect the MOSFETs from damage a hiccup timer limits the duty cycle to prevent thermal runaway. Refer to the [Switching Characteristics](#) for MOSFET hiccup timing.

- Buck average current limit: No MOSFET, CSN/OUT connected to BUS. For TPS25831-Q1, the LS_GD pin can be left floating. For TPS25830-Q1, the LS_GD pin must be pulled up through a 2.2-kΩ resistor. In this configuration, a voltage of 1 V across R_{ILIMIT} on the ILIMIT pin initiates average current limiting of the buck regulator.

The two level current limit is described below:

- With external MOSFET [Figure 10-16](#), [Figure 10-17](#):
 - Isolating a fault on the USB port from other loads connected to the CSP output of the TPS2583x-Q1. In some applications, it may be useful to power additional circuitry (example USB HUB) from the output of the TPS2583x-Q1 and maintain operation of these circuits in the event of a short circuit downstream of the BUS pin. To prevent triggering the MOSFET current limit below the programmed ILIMIT threshold, external circuits must be supplied after the inductor and before the current sense resistor, R_{SNS}.
 - After R_{SNS} and R_{SET} are determined and the full load I_{SET} current is known, the resistor value R_{ILIMIT} can be determined by:

$$R_{ILIMIT} = \frac{0.49 \times R_{SET}}{0.5 \times (I_{LIMIT} \times R_{SNS} + 0.0007)} \quad (6)$$

- In most case, the recommended voltage across R_{SNS} under current limit should be approximately 50 mV as a compromise between accuracy and power dissipation. While in some application, R_{ILIMIT} is the only resistor that can be changed to achieve different current limit. Typical R_{ILIMIT} resistors value are listed in [Table 10-2](#) given the condition R_{SNS}= 15 mΩ and R_{SET}= 300 Ω

Table 10-2. Setting the Current Limit with R_{ILIMIT}

Current-Limit Threshold (mA)	R _{ILIMIT} (kΩ)	
	With External MOSFET	Buck Average
700	26.1	53.6
1500	12.7	26.1
1700	11.3	22.6
2700	7.15	14.7
3000	6.49	13
3400	5.62	11.5
3800	5.11	10.5

- Buck Average Current Limit, [Figure 10-18](#), [Figure 10-19](#):
 1. CSN/OUT connected directly to BUS. For TPS25831-Q1, LS_GD pin can be floating. For TPS25830-Q1, LS_GD pin must be pulled up through a 2.2-kΩ resistor. The TPS2583x-Q1 can operate as a stand-alone USB charging port. In this configuration, the internal buck regulator operates with average current limiting as programmed by the ILIMIT pin, potentially producing less heat compared to N-channel MOSFET current limiting
 2. After R_{SNS} and R_{SET} are determined and the full load I_{SET} current is known, the resistor value R_{ILIMIT} can be determined by:

$$R_{ILIMIT} = \frac{1 \times R_{SET}}{0.5 \times (I_{LIMIT} \times R_{SNS} + 0.0007)} \quad (7)$$

3. Typical R_{ILIMIT} resistors value are listed in [Table 10-2](#) given the condition R_{SNS}= 15 mΩ and R_{SET}= 300 Ω

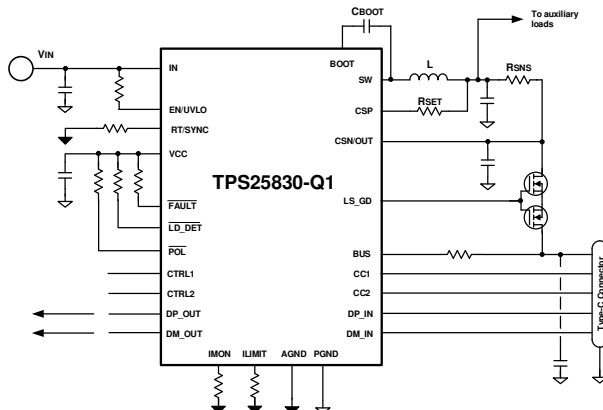

Figure 10-16. TPS25830-Q1 Current Limit with External MOSFET

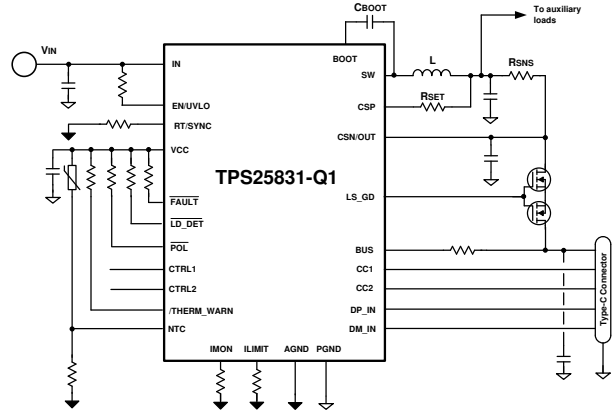

Figure 10-17. TPS25831-Q1 Current Limit with External MOSFET

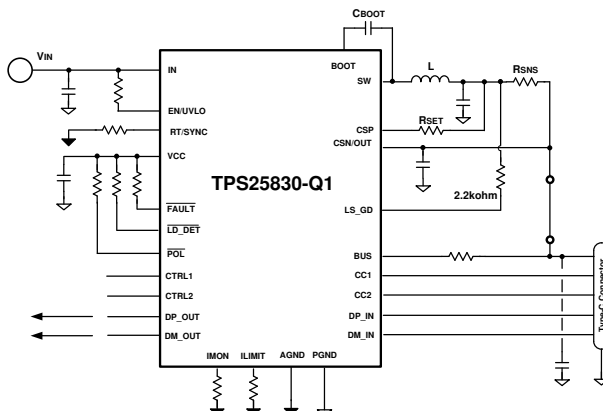

Figure 10-18. TPS25830-Q1 Buck Average Current Limit

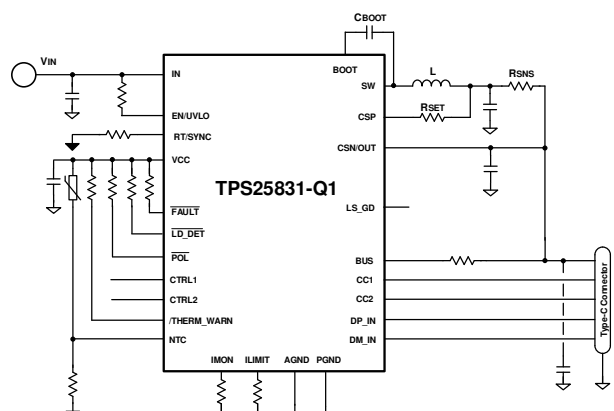

Figure 10-19. TPS25831-Q1 Buck Average Current Limit

10.3.10.2 Buck Average Current Limit Design Example

To start the procedure, the $I_{LOAD(MAX)}$, R_{SNS} , R_{SET} , must to be known.

1. Determine I_{LIMIT} , usually chose $I_{LIMIT} = I_{LOAD(MAX)} / (1 - 10\%)$.
2. Determine R_{SNS} to achieve 50 mV at current limit. For 3-A Type-C load current, choose $I_{LIMIT} = 3.3A$. $R_{SNS} = (0.05 V / 3.3 A) = 15 m\Omega$.
3. Choose $R_{SET} = 300 \Omega$
4. According to Equation 7, $R_{LIMIT} = 300 / (0.5 \times (3.3 \times 0.015 + 0.0007)) = 11.95 k\Omega$.
5. Choose standard 11.8 k Ω .

10.3.10.3 External MOSFET Gate Drivers

The TPS2583x-Q1 has integrated NFET gate drivers, and can support current limit with external NFET. Refer to Figure 10-16.

The LS_GD pin of TPS2583x-Q1 can source 3 uA (typical) current to enhance the external MOSFET. A 6.2-V clamp between LS_GD and CSN/OUT pin limits the gate-to-source voltage. During DCDC start up, the LS_GD gate drivers begin to source current after $V_{CSN/OUT}$ reach 3 V. If the $V_{CSN/OUT} > 7.5 V$ or $V_{BUS} > 7 V$ under overvoltage condition, the LS_GD will turn off immediately with 35 uA (typical) sink current.

If load current above NFET current limit threshold, LS_GD will also turn off the NFET after 2 ms (Typical) and enter hiccup mode to protect NFET from thermal issue. Refer to Figure 11-26 for application waveform.

In real application, if V_{BUS} short to V_{BAT} function is needed, 20-V back-to-back NFET is suggested in circuit design.

10.3.10.4 Cycle-by-Cycle Buck Current Limit

The buck regulator cycle-by-cycle current limit on both the peak and valley of the inductor current. Hiccup mode will be activated if a fault condition persists to prevent over-heating.

High-side MOSFET overcurrent protection is implemented by the nature of the Peak Current Mode control. The HS switch current is sensed when the HS is turned on after a set blanking time. The HS switch current is compared to the output of the Error Amplifier (EA) minus slope compensation every switching cycle. Refer to [Functional Block Diagram](#) for more details. The peak current of HS switch is limited by a clamped maximum peak current threshold I_{HS_LIMIT} which is constant. So the peak current limit of the high-side switch is not affected by the slope compensation and remains constant over the full duty cycle range.

The current going through LS MOSFET is also sensed and monitored. When the LS switch turns on, the inductor current begins to ramp down. The LS switch will not be turned OFF at the end of a switching cycle if its current is above the LS current limit I_{LS_LIMIT} . The LS switch will be kept ON so that inductor current keeps ramping down, until the inductor current ramps below the LS current limit I_{LS_LIMIT} . Then the LS switch will be turned OFF and the HS switch will be turned on after a dead time. This is somewhat different than the more typical peak current limit, and results in [Equation 8](#) for the maximum load current.

$$I_{OUT_MAX} = 0.5 \times (I_{LS_LIMIT} + I_{HS_LIMIT}) \quad (8)$$

If $V_{CSN/OUT} < 2\text{-V}$ typical due to a short circuit for 128 consecutive cycles, hiccup current protection mode will be activated. In hiccup mode, the regulator will be shut down and kept off for 118 ms typically, then TPS2583x-Q1 go through a normal re-start with soft start again. If the short-circuit condition remains, hiccup will repeat until the fault condition is removed. Hiccup mode reduces power dissipation under severe overcurrent conditions, prevents over-heating and potential damage to the device and serves as a backup to the programmable current limit see the [Current Limit Setting using \$R_{LIMIT}\$](#) section. Once the output short is removed, the hiccup delay is passed, the output voltage recovers normally as shown in [Figure 11-23](#).

10.3.11 Overvoltage, IEC and Short to Battery Protection

The TPS2583x-Q1 integrates OVP and short to battery protection on VBUS, CC1, CC2, DM_IN and DP_IN pins. These pins can withstand voltage up to 18 V, and can protect upstream processor or Hub data line when overvoltage or short to battery condition occurs. Refer to [Figure 9-5](#) for short to battery test setup.

For more detailed TPS2583x-Q1 Short to Battery consideration and test report, please refer to the [TPS2583x-Q1 and TPS2584x-Q1 Short-to- Battery Application application report](#).

The TPS2583x-Q1 also integrates IEC ESD cell on CC1, CC2, DP_IN and DM_IN pins.

10.3.11.1 V_{BUS} and $V_{CSN/OUT}$ Overvoltage Protection

The TPS2583x-Q1 integrates overvoltage protection on both BUS and CSN/OUT pin, to meet different application requirement.

BUS pin can withstand up to 18 V, and the OVP threshold is 7-V typical. Once overvoltage is detected on BUS pin, the LS_GD will turn off immediately, also $\overline{\text{FAULT}}$ asserts after 8-ms deglitch time. Once the excessive voltage is removed, the LS_GD will turn on again and $\overline{\text{FAULT}}$ deasserts.

CSN/OUT pin can withstand up to 20 V, and the OVP threshold is 7.5-V typical. Once overvoltage is detected on CSN/OUT pin, the buck converter will stop regulation, also LS_GD will turn off immediately. Once the excessive voltage is removed, the buck converter will resume and LS_GD turn on again.

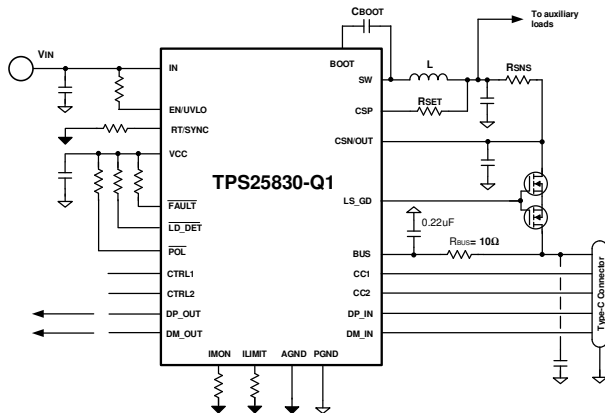

Figure 10-20. Current Limit With External MOSFET

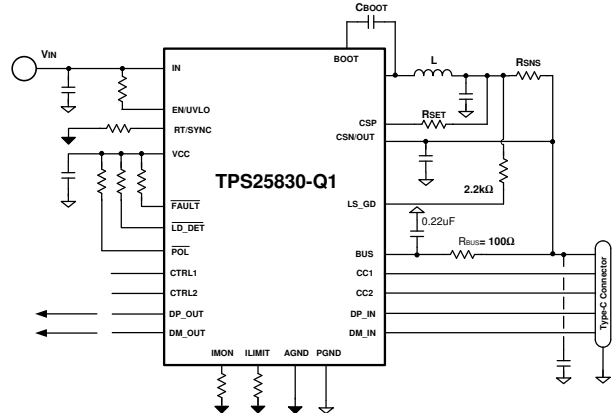

Figure 10-21. Buck Average Current Limit

TPS2583x-Q1 is configured in external FET current limit mode as shown in [Figure 10-20](#). When short to battery occurs on BUS_Connector, the external MOSFET will be turn off immediately after BUS pin detect overvoltage. The $\overline{\text{FAULT}}$ signal will assert after 8-ms deglitch time, see [Figure 11-31](#). With Back-to-back FET, the TPS2583x-Q1 can withstand short to battery event even when V_{in} is off. A 10- Ω 0805 resistor is recommended between BUS pin and BUS_Connector.

TPS2583x-Q1 is configured in buck average current limit mode as shown in [Figure 10-21](#). When short to battery occurs on BUS_Connector, the buck regulator will stop switching after CSN/OUT pin detect overvoltage. The $\overline{\text{FAULT}}$ signal will also assert after 8-ms deglitch time. A 100- Ω 0805 resistor is recommended between BUS pin and BUS_Connector in buck average current limit mode.

10.3.11.2 DP_IN and DM_IN Protection

DP_IN and DM_IN protection consists of IEC ESD and overvoltage protection.

The DP_IN and DM_IN pins integrate an IEC ESD cell to provide ESD protection up to ± 15 -kV air discharge and ± 8 -kV contact discharge per IEC 61000-4-2 (See the [ESD Ratings](#) section for test conditions). The IEC ESD performance of the TPS2583x-Q1 device depends on the capacitance connected from BUS pin to GND. A 0.22- μF capacitor placed close to the BUS pin is recommended.

The ESD stress seen at DP_IN and DM_IN is impacted by many external factors like the parasitic resistance and inductance between ESD test points and the DP_IN and DM_IN pins. For air discharge, the temperature and humidity of the environment can cause some difference, so the IEC performance should always be verified in the end-application circuit.

Overvoltage protection (OVP) is provided for short-to- V_{BUS} or short-to-battery conditions in the vehicle harness, preventing damage to the upstream USB transceiver or hub. When the voltage on DP_IN or DM_IN exceeds 3.9 V (typical), the TPS2583x-Q1 device immediately turn off DP/DM switch, and responds to block the high-voltage reverse connection to DP_OUT and DM_OUT. $\overline{\text{FAULT}}$ signal will assert after 8ms deglitch time, see [Figure 11-35](#).

For DP_IN and DM_IN, when OVP is triggered, the device turns on an internal discharge path with 416-k Ω resistance to ground. On removal of the overvoltage condition, the pin automatically turns off this discharge path and returns to normal operation by turning on the previously affected analog switch.

10.3.11.3 CC IEC and OVP Protection

CCx protection consists of IEC ESD and overvoltage protection.

The CC pins integrate an IEC ESD cell to provide ESD protection up to ± 1 - kV air discharge and ± 8 -kV contact discharge per IEC 61000-4-2 (See the [ESD Ratings](#) section for test conditions). An additional 0.22- μF capacitor placed close to the CC pin is recommended in real application.

Overvoltage protection (OVP) is provided for short-to- V_{BUS} or short-to-battery conditions in the vehicle harness. When the voltage on CC1 or CC2 exceeds 6.1 V (typical), the TPS2583x-Q1 device immediately shut off CC line. FAULT signal will assert after 8-ms deglitch time. See [Figure 11-33](#).

For CC1 and CC2, when OVP is triggered, the device turns on an internal discharge path with 55-k Ω resistance to ground. On removal of the overvoltage condition, the pin automatically turns off this discharge path and returns to normal operation.

10.3.12 Cable Compensation

When a load draws current through a long or thin wire, there is an IR drop that reduces the voltage delivered to the load. Cable droop compensation linearly increases the voltage at the CSN/OUT pin of TPS2583x-Q1 as load current increases with the objective of maintaining V_{BUS_CON} (the bus voltage at the USB connector) at 5 V, regardless of load conditions. Most portable devices charge at maximum current when 5 V is present at the USB connector. [Figure 10-22](#) provides an example of resistor drops encountered when designing an automotive USB system with a remote USB connector location.

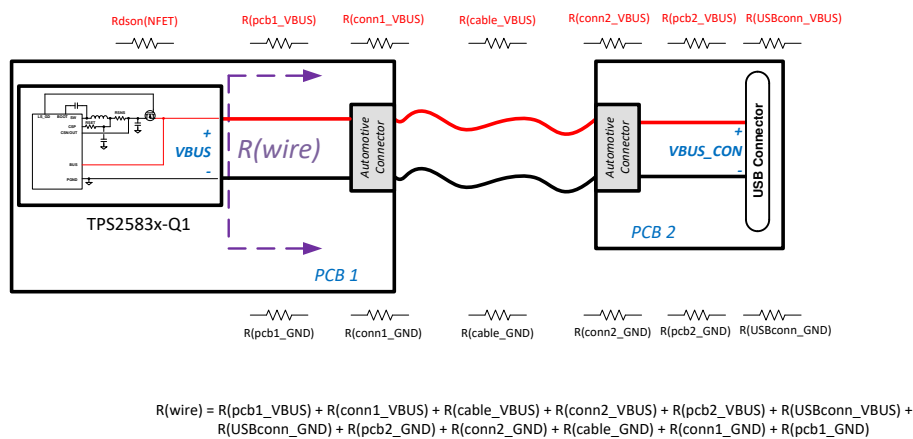

Figure 10-22. Automotive USB Resistances

The TPS2583x-Q1 detects the load current and increases the voltage at the CSN/OUT pin to compensate the IR drop in the charging path according to the gain set by the R_{SNS} , R_{SET} , and R_{IMON} resistors as described in [R_{SNS}](#), [R_{SET}](#), [R_{LIMIT}](#), and [R_{IMON}](#).

The amount of cable droop compensation required can be estimated by the following equation $\Delta V_{OUT} = (R_{SNS} + R_{DSON_NFET} + R_{WIRE}) \times I_{BUS}$. R_{IMON} is then chosen by $R_{IMON} = (\Delta V_{OUT} \times R_{SET} \times 2) / (I_{BUS} \times R_{SNS})$, where ΔV_{OUT} is the desired cable droop compensation voltage at full load.

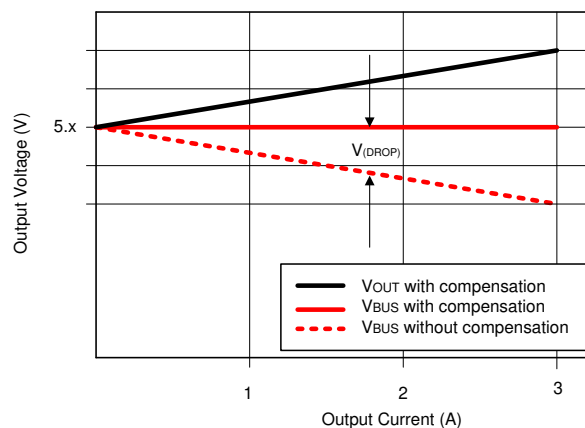

Figure 10-23. Voltage Drop

Per R_{SNS} , R_{SET} , R_{LIMIT} , and R_{IMON} , in most cases, the recommended voltage across R_{SNS} should be 50 mV. In type-C application, typical R_{IMON} resistors value are listed in [Table 10-3](#) given the condition full load current = 3 A, $R_{SNS} = 15\text{ m}\Omega$ and $R_{SET} = 300\ \Omega$.

Table 10-3. Setting the Cable Compensation Voltage with R_{IMON}

Cable Compensation Voltage at 3-A Full Load (V)	R_{IMON} (k Ω)
0.3	4.02
0.6	8.06
0.9	12.1
1.2	16.2
1.5	20

Pls be noted that the max cable compensation voltage in TPS2583x-Q1 is 1.5 V.

10.3.12.1 Cable Compensation Design Example

To start the procedure, the R_{SNS} , R_{DSON_NFET} and wire resistance R_{WIRE} , must to be known.

- Determine R_{SNS} to achieve 50 mV at full current. For 3.3 A (3-A Type-C load current plus at approximately 10% for overcurrent threshold). $R_{SNS} = (0.05\text{ V} / 3.3\text{ A}) = 15\text{ m}\Omega$.
- $R_{DSON_NFET} = 50\text{ m}\Omega$
- $R_{WIRE} = 200\text{ m}\Omega$
- $\Delta V_{OUT} = (R_{SNS} + R_{DSON_NFET} + R_{WIRE}) \times I_{BUS} = (0.015 + 0.05 + 0.2) \times 3 = 0.795\text{ V}$
- Choose $R_{SET} = 300\ \Omega$
- $R_{IMON} = (\Delta V_{OUT} \times R_{SET} \times 2) / (I_{BUS} \times R_{SNS}) = (0.795 \times 300 \times 2) / (3 \times 0.015) = 10.6\text{ k}\Omega$

10.3.13 USB Port Control

The TPS25830-Q1 and TPS25831-Q1 include DP_IN, DM_IN, CC1 and CC2 pins for automatic or host facilitated USB port power management of either a Type-A or Type-C downstream facing connector. See the [Device Functional Modes](#) section for details on configuring the TPS2583x-Q1.

10.3.14 FAULT Response

The device features an active-low, open-drain fault output. Connect a 100-k Ω pullup resistor from $\overline{\text{FAULT}}$ to VCC or other suitable I/O voltage. $\overline{\text{FAULT}}$ can be left open or tied to GND when not used.

[Table 10-4](#) summarizes the conditions that generate a fault and actions taken by the device.

Table 10-4. Fault and Warning Conditions

EVENT	CONDITION	ACTION
Overcurrent on OUT	NFET or Buck average current limit implemented per Current Limit Setting using R_{LIMIT} . $I_{CSN/OUT} > \text{programmed } I_{SNS}$.	The device regulates current at I_{SNS} either by external NFET or by the buck regulator control loop. When current limiting by external NFET, there is NO fault indicator assertion under minor overload conditions. When current limiting by buck average current, there is NO fault indicator assertion under minor overload conditions. Hard shorts during average buck current limiting may trigger buck hiccup operation. The $\overline{\text{FAULT}}$ indicator asserts immediately after N_{OC} cycles in and persists for T_{OC} as specified in the Cycle-by-Cycle Buck Current Limit section.
Overvoltage on BUS	$V_{BUS} > V_{BUS_OV}$	The device turns on the BUS discharge path in the event of an overvoltage conditions, and turn off the LS_GD immediately. The $\overline{\text{FAULT}}$ indicator asserts and de-asserts with a 8-ms deglitch.
Overvoltage on the data lines	DP_IN or DM_IN $> V_{Dx_IN_OV}$	The device immediately shuts off the USB data switches. The $\overline{\text{FAULT}}$ indicator asserts and de-asserts with a 8-ms deglitch.
Overvoltage on CC lines	CC1 or CC2 $> V_{CCx_OV}$	The device immediately shuts off the CC lines. The $\overline{\text{FAULT}}$ indicator asserts and de-asserts with a 8-ms deglitch.

Table 10-4. Fault and Warning Conditions (continued)

EVENT	CONDITION	ACTION
Overcurrent on CC lines when supplying VCONN	$I_{LOAD_CCn} > I_{OS_CCn}$	The FAULT indicator asserts and de-asserts with a 8-ms deglitch. The FAULT indicator remains asserted during the VCONN overload condition and the VCONN path is not disabled.
TPS25831-Q1 External overtemperature detection (NTC)	$V_{NTC} \geq V_{WARN_HIGH}$	Thermal warning flag THERM_WARN asserts immediately. Also the type-C advertise current will change to 1.5 A if operate with 3 A originally. The FAULT flag is not asserted for this condition, but will assert for conditions stated in this table.
TPS25831-Q1 External overtemperature detection (NTC)	$V_{NTC} \geq V_{SD_HIGH}$	The device immediately shuts off the buck regulator, opens the USB data switches, while simultaneously pulling LS_GD and BUS low. The THERM_WARN indicator remains asserted.

10.3.15 USB Specification Overview

Universal Serial Bus specifications provide critical physical and electrical requirements to electronics manufacturers of USB capable equipment. Adherence to these specifications during product development coupled with standardized compliance testing assures very high degrees of interoperability amongst USB products in the market. Since its inception in the mid 1990s, USB has undergone a number of revisions to enhance utility and extend functionality. For the most up to date standards, please consult the USB Implementers Forum (USB-IF).

All USB ports are capable of providing a 5-V output making them a convenient power source for operating and charging portable devices. USB specification documents outline specific power requirements to ensure interoperability. In general, a USB 2.0 port host port is required to provide up to 500 mA; a USB 3.0 or USB 3.1 port is required to provide up to 900 mA; ports adhering to the USB Battery Charging 1.2 Specification provide up to 1500 mA; and newer Type-C ports can provide up to 3000 mA. Though USB standards governing power requirements exist, some manufacturers of popular portable devices created their own proprietary mechanisms to extend allowed available current beyond the 1500-mA maximum per BC 1.2. While not officially part of the standards maintained by the USB-IF, these proprietary mechanisms are recognized and implemented by manufacturers of USB charging ports.

The TPS2583x-Q1 device supports five of the most-common USB-charging schemes found in popular hand-held media and cellular devices.

- USB Type-C (1.5 A and 3 A advertisement)
- USB Battery Charging Specification BC1.2
- Chinese Telecommunications Industry Standard YD/T 1591-2009
- Divider 3 mode
- 1.2-V mode

The BC1.2 specification includes three different port types:

- Standard downstream port (SDP)
- Charging downstream port (CDP)
- Dedicated charging port (DCP)

BC1.2 defines a charging port as a downstream-facing USB port that provides power for charging portable equipment. Under this definition, CDP and DCP are defined as charging ports.

Table 10-5 lists the difference between these port types.

Table 10-5. USB Operating Modes Table

PORT TYPE	SUPPORTS USB2.0 COMMUNICATION	MAXIMUM ALLOWABLE CURRENT DRAWN BY PORTABLE EQUIPMENT (A)
SDP (USB 2.0)	YES	0.5
SDP (USB 3.0 and 3.1)	YES	0.9
CDP	YES	1.5

Table 10-5. USB Operating Modes Table (continued)

PORT TYPE	SUPPORTS USB2.0 COMMUNICATION	MAXIMUM ALLOWABLE CURRENT DRAWN BY PORTABLE EQUIPMENT (A)
DCP	NO	1.5
TYPE-C	YES	3.0

10.3.16 USB Type-C® Basics

For a detailed description of the Type-C specifications refer to the USB-IF website to download the latest information. Understanding the basic concepts of the USB Type-C specification will aid in understanding the operation of the TPS2583x-Q1 (a DFP device).

USB Type-C removes the need for different plug and receptacle types for host and device functionality. The Type-C receptacle replaces both Type-A and Type-B receptacle since the Type-C cable is plug-able in either direction between host and device. A host-to-device logical relationship is maintained via the configuration channel (CC). Optionally hosts and devices can be either providers or consumers of power when USB Power Delivery (PD) communication is used to swap roles.

All USB Type-C ports operate in one of below three data modes:

- Host mode: the port can only be host (provider of power)
- Device mode: the port can only be device (consumer of power)
- Dual-Role mode: the port can be either host or device

Port types:

- DFP (Downstream Facing Port): Host
- UFP (Upstream Facing Port): Device
- DRP (Dual-Role Port): Host or Device

Valid DFP-to-UFP connections:

- [Table 10-6](#) describes valid DFP-to-UFP connections
- Host to Host or Device to Device have no functions

Table 10-6. DFP-to-UFP Connections

	HOST-MODE PORT	DEVICE-MODE PORT	DUAL-ROLE PORT
Host-Mode Port	No Function	Works	Works
Device-Mode Port	Works	No Function	Works
Dual-Role Port	Works	Works	Works ⁽¹⁾

(1) This may be automatic or manually driven.

10.3.16.1 Configuration Channel

The function of the configuration channel is to detect connections and configure the interface across the USB Type-C cables and connectors.

Functionally the Configuration Channel (CC) is used to serve the following purposes:

- Detect connect to the USB ports
- Resolve cable orientation and twist connections to establish USB data bus routing
- Establish DFP and UFP roles between two connected ports
- Discover and configure power: USB Type-C current modes or USB Power Delivery
- Discovery and configure optional Alternate and Accessory modes
- Enhance flexibility and ease of use

Typical flow of DFP to UFP configuration is shown in [Figure 10-24](#):

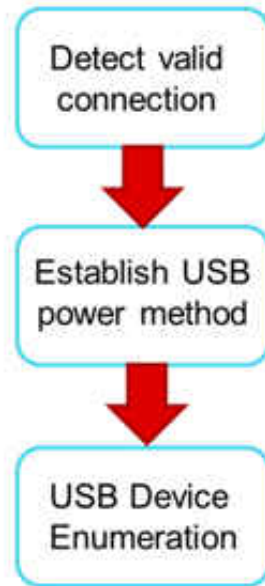

Figure 10-24. Flow of DFP to UFP Configuration

10.3.16.2 Detecting a Connection

DFPs and DRPs fulfill the role of detecting a valid connection over USB Type-C. Figure 10-25 shows a DFP to UFP connection made with Type C cable. As shown in Figure 10-25, the detection concept is based on being able to detect terminations in the product which has been attached. A pull-up and pull-down termination model is used. A pull-up termination can be replaced by a current source. TPS2583x-Q1 devices use current sources in lieu of R_p as allowed by the Type-C specification.

- In the DFP-UFP connection the DFP monitors both CC pins for a voltage lower than the unterminated voltage.
- An UFP advertises R_d on both its CC pins (CC1 and CC2).
- A powered cable advertises R_a on only one of CC pins of the plug. R_a is used to inform the source to apply VCONN.
- An analog audio device advertises R_a on both CC pins of the plug, which identifies it as an analog audio device. VCONN is not applied on either CC pin in this case.

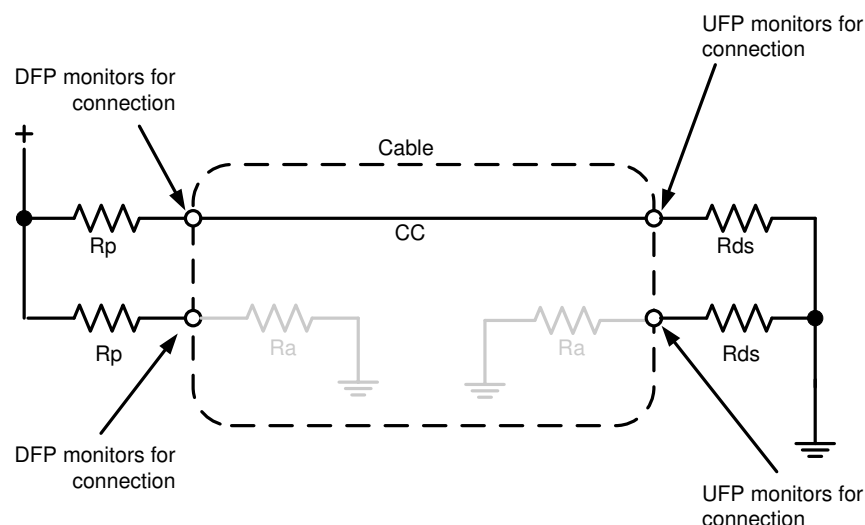

Figure 10-25. DFP-UFP Connection

10.3.16.3 Configuration Channel Pins CC1 and CC2

The TPS2583x-Q1 has two pins, CC1 and CC2 that serve to detect an attachment to the port and resolve cable orientation. These pins are also used to establish current broadcast to a valid UFP and configure VCONN.

Table 10-7 lists TPS2583x-Q1 response to various attachments to its port.

Table 10-7. TPS2583x-Q1 Response

TPS2583x-Q1 TYPE-C PORT	CC1	CC2	TPS2583x-Q1 RESPONSE ⁽¹⁾				
			BUCK REGULATOR	LS_GD	V _{CONN} On CC1 or CC2 ⁽²⁾	POL	LD_DET
Nothing Attached	OPEN	OPEN	OFF	OFF	NO	Hi-Z	Hi-Z
UFP Connected	Rd	OPEN	ON	ON	NO	Hi-Z	LOW
UFP Connected	OPEN	Rd	ON	ON	NO	LOW	LOW
Powered Cable/No UFP Connected	OPEN	Ra	OFF	OFF	NO	Hi-Z	Hi-Z
Powered Cable/No UFP Connected	Ra	OPEN	OFF	OFF	NO	Hi-Z	Hi-Z
Powered Cable/UFP Connected	Rd	Ra	ON	ON	CC2	Hi-Z	LOW
Powered Cable/UFP Connected	Ra	Rd	ON	ON	CC1	LOW	LOW
Debug Accessory Connected ⁽³⁾	Rd	Rd	OFF	OFF	NO	Hi-Z	Hi-Z
Audio Adapter Accessory Connected ⁽³⁾	Ra	Ra	OFF	OFF	NO	Hi-Z	Hi-Z

(1) POL and LD_DET are open drain outputs; pull high with 100 kΩ to VCC when used. Tie to GND or leave open when not used.

(2) To supply V_{CONN} a 5-V external LDO with at least 500-mA output current should be connected to the V_{CC} pin.

(3) The TPS2583x-Q1 does not support debug mode or audio mode.

10.3.16.4 Current Capability Advertisement and VCONN Overload Protection

The TPS2583x-Q1 supports all three Type-C current advertisements as defined by the USB Type-C standard. Current broadcast to a connected UFP is controlled by the CTRL1 and CTRL2 pins. For each broadcast level the device protects itself from a UFP that draws current in excess of the port's USB Type-C Current advertisement by setting the current limit as shown in Table 10-8.

Table 10-8. USB Type-C[®] Current Advertisement

DEVICE	CTRL1	CTRL2	CC CAPABILITY BROADCAST	MODE	SUPPORT USB 2.0 COMMUNICATION	CURRENT LIMIT (typ)
'830-Q1	0	0	RESERVED, DO NOT USE			
	0	1	RESERVED, DO NOT USE			
	1	0	1.5 A	SDP	YES: DP_IN to DP_OUT and DM_IN to DM_OUT	BY R _{SNS} , R _{SET} , R _{LIMIT}
	1	1	3 A	CDP	YES: DP_IN to DP_OUT and DM_IN to DM_OUT	
'831-Q1	0	0	RESERVED, DO NOT USE			
	0	1	3 A	DCP auto	NOT SUPPORT	BY R _{SNS} , R _{SET} , R _{LIMIT}
	1	0	1.5 A	SDP	Stub Connection Only	
	1	1	3 A	CDP	Stub Connection Only	

Under overload conditions, a precision current-limit circuit limits the VCONN output current. When a VCONN overload condition is present, the TPS2583x-Q1 maintains a constant output current, with the output voltage determined by (I_{OS_CCn} × R_{LOAD}). VCONN functionality is supported only with an external 5-V supply connected to VCC. Failure to connect an external supply may cause TPS2583x-Q1 Vcc reset. The device turns off when the junction temperature exceeds the thermal shutdown threshold, T_{SD} and remains off until the junction

temperature cools approximately 20°C and then restarts. The TPS2583x-Q1 current limit profile is shown in Figure 10-26.

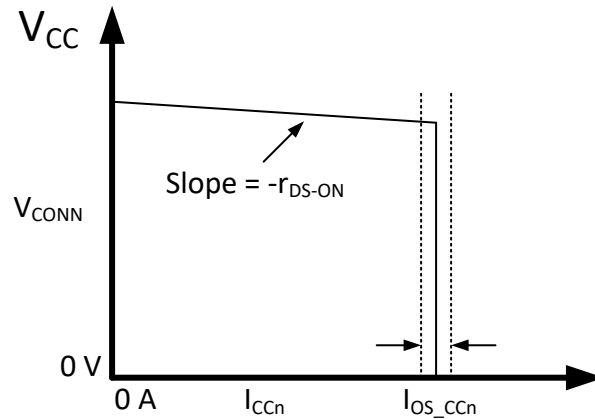

Figure 10-26. VCONN Current Limit Profile

10.3.16.5 Plug Polarity Detection

Reversible Type-C plug orientation is reported by the $\overline{\text{POL}}$ pin when a UFP is connected. However when no UFP is attached, $\overline{\text{POL}}$ remains de-asserted irrespective of cable plug orientation. Table 10-9 describes the $\overline{\text{POL}}$ state based on which device CC pin detects V_{RD} from an attached UFP pull-down.

Table 10-9. Plug Polarity Detection

CC1	CC2	$\overline{\text{POL}}$	STATE
Rd	Open	Hi-Z	UFP connected
Open	Rd	Asserted (pulled low)	UFP connected with reverse plug orientation

Figure 10-27 shows an example implementation that uses the $\overline{\text{POL}}$ terminal to control the SEL terminal on the HD3SS3212. The HD3SS3212 provides switching on the differential channels between Port B and Port C to Port A depending on cable orientation.

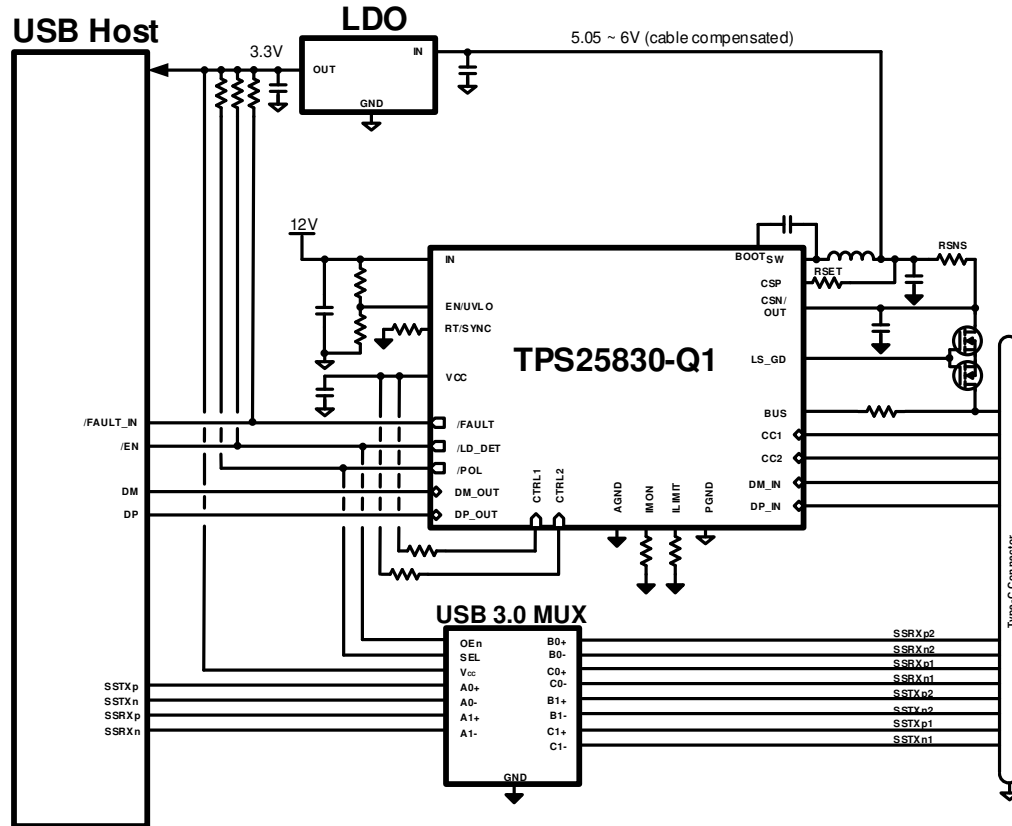

Figure 10-27. Example Implementation

10.3.17 Device Power Pins (IN, CSN/OUT, and PGND)

The IN pins are the input power path to the TPS2583x-Q1 devices. The internal LDO and buck regulator high side switch are supplied from the IN pins. The CSN/OUT pin connects to the negative terminal of the current sense amplifier and the internal voltage feedback network. This pin must be connected to the output LC filter for proper operation. PGND is the power ground return. For optimum performance, ensure the IN pin is properly bypassed to PGND with adequate bulk and high-frequency bypass capacitance located as close to these pins as possible.

10.3.18 Thermal Shutdown

The device has an internal overtemperature shutdown threshold, T_{SD} to protect the device from damage and overall safety of the system. When device temperature exceeds T_{SD} , the LD_GD pin is pulled low, and the buck regulator stops switching. The device attempts to power-up when die temperature decreases by approximately 20°C.

10.3.19 Power Wake

Legacy Type-A ports source 5 V on VBUS regardless of a load connection or not. In contrast, Type-C ports are "cold," 0 V, until a UFP connection has been detected with the CC lines. This fundamental change in VBUS operation enables a Type-C port to save power when no load is connected. The TPS2583x-Q1 devices monitor the CC lines for a UFP connection and enable the internal buck regulator to source VBUS after a UFP is detected. As a result idle port power consumption is reduced compared to Type-A port systems where the buck regulator operates continuously to supply VBUS, even when no load is connected.

10.3.20 Thermal Sensing with NTC (TPS25831-Q1)

The NTC input pin allows for user programmable thermal protection. See the [Electrical Characteristics](#) for NTC pin thresholds. The NTC input pin threshold is ratiometric with V_{CC} . The external resistor divider setting V_{NTC}

must be connected to the TPS25831-Q1 V_{CC} pin to achieve accurate results, see [Figure 10-28](#) and [Figure 10-29](#). When $V_{NTC} = 0.5 \times V_{CC}$ (approximately 2.5-V typically), the TPS25831-Q1 performs two actions:

1. If operating with 3-A Type-C advertisement, the CC1 and CC2 pin automatically reduces advertisement to the 1.5-A level.
2. The $\overline{\text{THERM_WARN}}$ flag is asserted to provide an indication of the over-temperature condition. $\overline{\text{FAULT}}$ is NOT asserted at this time.

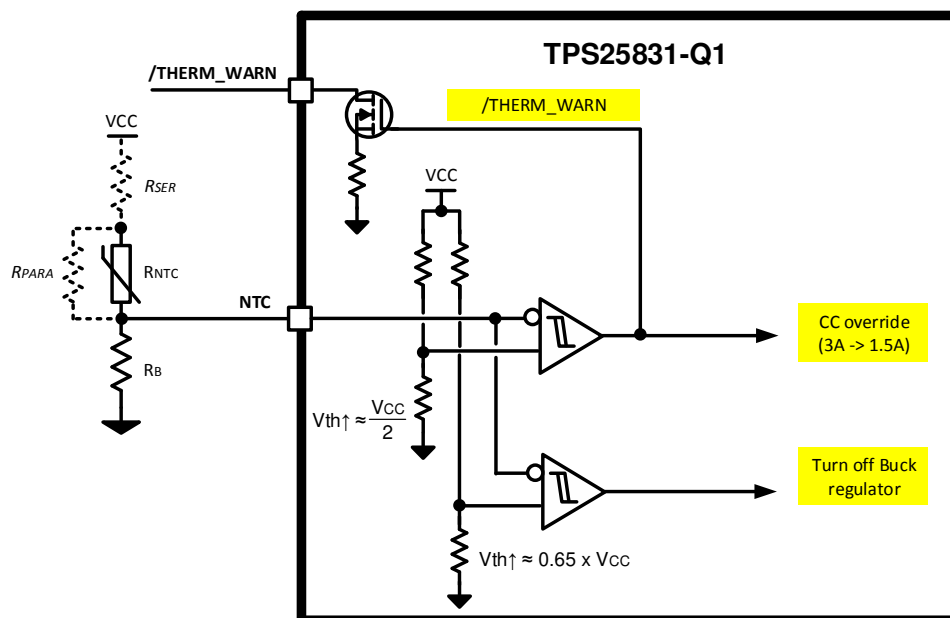

Figure 10-28. NTC Input Pin

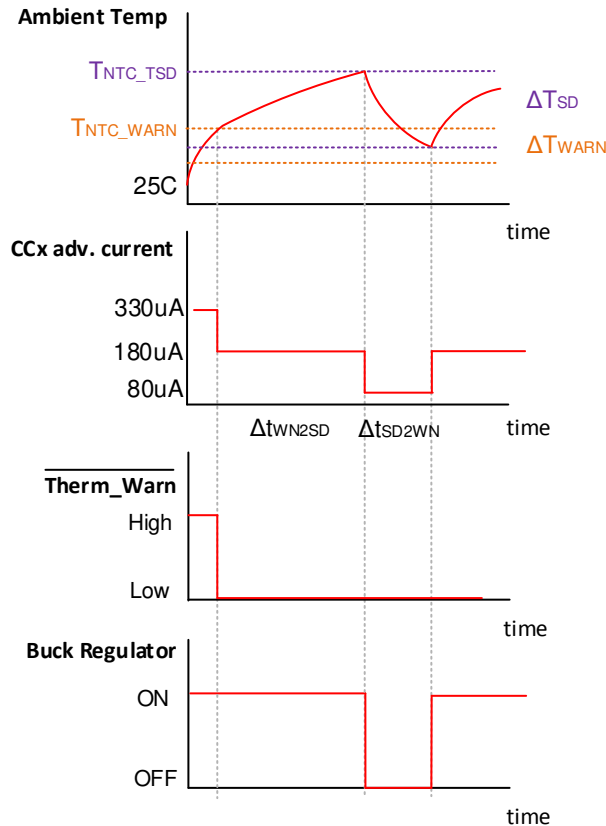

Figure 10-29. TPS25831-Q1 Behavior When Trigger NTC Threshold

If the overtemperature condition persists causing $V_{NTC} = V_{CC} \times 0.65$ (3.25-V typical), the TPS25831-Q1 turns off the buck regulator and pulls the LS_GD pin low. The `THERM_WARN` flag remains asserted; however, the `FAULT` pin is NOT asserted for this condition.

Tuning the V_{NTC} threshold levels of V_{WARN_HIGH} and V_{SD_HIGH} is achieved by adding R_{SER} , R_{PARA} , or both R_{SER} and R_{PARA} in conjunction with R_{NTC} . Figure 10-30 is an example illustrating how to set the `THERM_WARN` threshold between 75°C and 90°C with a ΔT between `THERM_WARN` assertion and device shutdown of 17°C to 28°C. Consult the chosen NTC manufacturer's specification for the value of β . It may take some iteration to establish the desired warning and shutdown thresholds.

Below is NTC spec and resistor value used in Figure 10-30 example.

- $R_0 = 470 \text{ k}\Omega$. $\beta = 4750$. $R_{NTC} = R_0 \times \exp \beta \times (1/T - 1/T_0)$
- $R_{PARA} = 100 \text{ k}\Omega$.
- $R_{SER} = 5 \text{ k}\Omega$.
- $R_B = R_{NTC}(\text{at } T_{\text{THERM_WARN}}) = 32 \text{ k}\Omega$

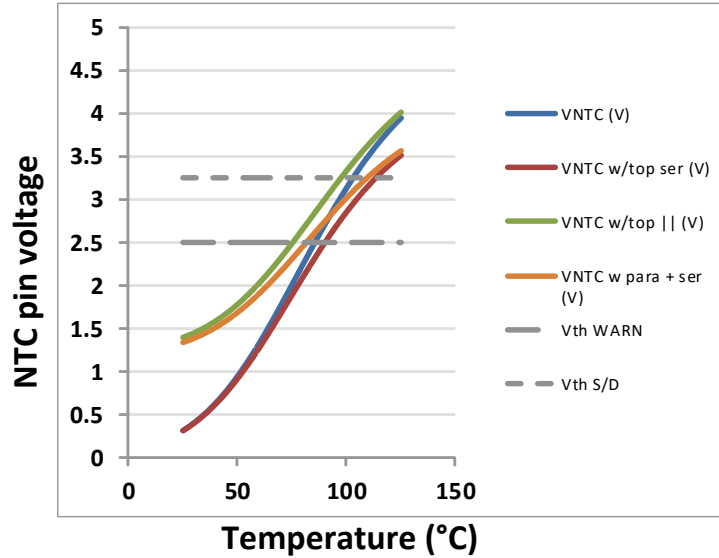

Example

Rising Thresholds	V (V)	T _{NTC} (°C)	T _{NTC} (°C)	T _{NTC ser} (°C)	T _{NTC} + ser (°C)	
Thermal Warning	=VCC * 0.5	2.5	85	75	90	81
NTC Shutdown	=VCC * 0.65	3.25	102	97	113	109
Δ (S/D - WARN)			17	22	23	28

Figure 10-30. V_{NTC} Threshold Examples

The NTC resistor should be placed near the hottest point on the PCB. In most cases, this will be close to the SW node of the TPS25831-Q1, near the buck inductor, R_{SNS} sense resistor and external MOSFETs (if used).

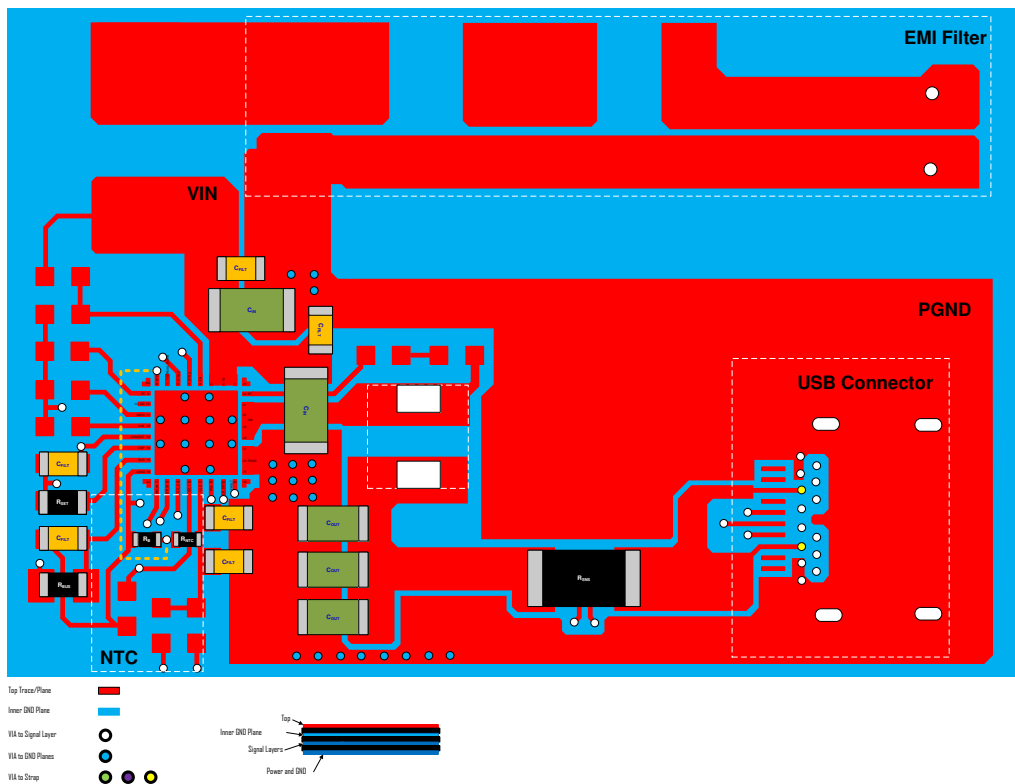

Figure 10-31. NTC Placement Example

10.4 Device Functional Modes

10.4.1 Shutdown Mode

The EN pin provides electrical ON and OFF control for the TPS2583x. When V_{EN} is below 1.2 V (typical), the device is in shutdown mode. The TPS2583x-Q1 also employs V_{IN} and V_{CC} undervoltage lock out protection. If V_{IN} or V_{CC} voltage is below their respective UVLO level, the regulator will be turned off.

10.4.2 Standby Mode

If the EN pin is pulled above the EN threshold, and there is no active connection on the CC lines, TPS2583x-Q1 remains in a low-power state with the buck converter off until a valid UFP (sink) is detected with a valid R_D on either CC1 or CC2. This mode ensures the Type-C 0 V V_{BUS} requirement is met and saves system power when no device is connected.

10.4.3 Active Mode

The TPS2583x-Q1 is in Active Mode when V_{EN} is above the precision enable threshold, V_{IN} and V_{CC} are above their respective UVLO levels *and* a valid detection has been made on the CC lines. The simplest way to enable the TPS2583x-Q1 is to connect the EN pin to VIN pin. This connection allows self startup when the input voltage is in the operating range: 3.8 V to 36 V and a UFP detection is made. Refer to [VCC](#), [VCC_UVLO](#) and [Enable/UVLO and Start-up](#) for details on setting these operating levels.

In Active Mode, the TPS2583x-Q1 buck regulator operates with Forced Pulse Width Modulation (FPWM), also referred to as Forced Continuous Conduction Mode (FCCM). This operation ensures the buck regulator switching frequency remains constant under all load conditions. FPWM operation provides low output voltage ripple, tight output voltage regulation, and constant switching frequency. Built-in spread-spectrum modulation aids in distributing spectral energy across a narrow band around the switching frequency programmed by the RT/SYNC pin. Under light load conditions the inductor current is allowed to go negative. A negative current limit of I_{L_NEG} is imposed to prevent damage to the regulator's low side FET. During operation the TPS2583x-Q1 will synchronize to any valid clock signal on the RT/SYNC input.

10.4.4 Device Truth Table (TT)

The device truth table ([Table 10-10](#)) lists all valid combinations for the two control pins (CTRL1 and CTRL2). The TPS2583x-Q1 devices monitor the CTRL inputs and transitions to whichever charging mode it is commanded.

Table 10-10. Truth Table

DEVICE	CTR L1	CTR L2	CURRENT LIMIT SETTING	USB MODES	BUCK REGULATOR	LS_GD	LD_DET (OUTPUT)	POL (OUTPUT)	FAULT (OUTPUT)	NTC (ANALOG INPUT)
TPS25830-Q1	0	0	RESERVED, DO NOT USE							
	0	1	RESERVED, DO NOT USE							
	1	0	See Current Limit Setting using R_{LIMIT}	Type-C (1.5 A) + SDP Mode	functional, see Table 10-7				Functional, see Table 10-4	n/a
	1	1		Type-C (3 A) + CDP Mode						n/a
TPS25831-Q1	0	0	RESERVED, DO NOT USE							
	0	1	Current Limit Setting using R_{LIMIT}	Type-C (3 A) + DCP Auto Mode	Functional, see Table 10-7				Functional, see Table 10-4	functional
	1	0		Type-C (1.5 A) + SDP Mode						functional
	1	1		Type-C (3 A) + CDP Mode						functional

10.4.5 USB Port Operating Modes

10.4.5.1 USB Type-C Mode

The TPS2583x-Q1 is a Type-C controller that supports all Type-C functions in a downstream facing port. It is also used to manage current advertisement and protection to a connected UFP and active cable. When VIN

exceeds the undervoltage lockout threshold, the device samples the EN pin. A high level on this pin enables the device and normal operation begins. Having successfully completed its start-up sequence, the device now actively monitors its CC1 and CC2 pins for attachment to a UFP. When a UFP is detected on either the CC1 or CC2 pin the buck regulator turn-ons after the required de-bounce time is met. If connected, the LS_GD pin sources current into the external MOSFET allowing current to flow from CSN/OUT to BUS. If Ra is detected on the other CC pin (not connected to UFP), VCONN is applied to allow current to flow from VCC to the CC pin connected to Ra. For a complete listing of various device operational modes refer to [Table 10-7](#).

The TPS2583x-Q1 always starts in Type-C mode, then transitions to DCP, CDP, or SDP as determined by the CTRL1 and CTRL2 pins and signaling by the connected portable device on the DP_IN and DM_IN pins.

10.4.5.2 Standard Downstream Port (SDP) Mode — USB 2.0, USB 3.0, and USB 3.1

A SDP is a traditional USB port that follows USB 2.0, USB 3.0 or USB 3.1 protocol. A USB 2.0 SDP supplies a minimum of 500 mA per port and supports USB 2.0 communications. A USB 3.x SDP supplies a minimum of 900 mA per port and supports USB 3.0 or USB 3.1 communications. For both types, the host controller must be active to allow charging.

10.4.5.3 Charging Downstream Port (CDP) Mode

A CDP is a USB port that follows USB BC1.2 and supplies a minimum of 1.5 A per port. A CDP provides power and meets the USB 2.0 requirements for device enumeration. USB-2.0 communication is supported, and the host controller must be active to allow charging. The difference between CDP and SDP is the host-charge handshaking logic that identifies this port as a CDP. A CDP is identifiable by a compliant BC1.2 client device and allows for additional current draw by the client device.

The CDP handshaking process occurs in two steps. During step one, the portable equipment outputs a nominal 0.6-V output on the DP line and reads the voltage input on the DM line. The portable device detects the connection to an SDP if the voltage is less than the nominal data-detect voltage of 0.3 V. The portable device detects the connection to a CDP if the DM voltage is greater than the nominal data detect voltage of 0.3 V and optionally less than 0.8 V.

The second step is necessary for portable equipment to determine whether the equipment is connected to a CDP or a DCP. The portable device outputs a nominal 0.6-V output on the DM line and reads the voltage input on the DP line. The portable device concludes the equipment is connected to a CDP if the data line being read remains less than the nominal data detects voltage of 0.3 V. The portable device concludes it is connected to a DCP if the data line being read is greater than the nominal data detect voltage of 0.3 V.

10.4.5.4 Dedicated Charging Port (DCP) Mode (TPS25831-Q1 Only)

A DCP only provides power and does not support data connection to an upstream port. As shown in the following sections, a DCP is identified by the electrical characteristics of the data lines. The TPS25831-Q1 only emulates one state, DCP-auto state. In the DCP-auto state, the device charge-detection state machine is activated to selectively implement charging schemes involved with the shorted, divider3 and 1.2-V modes. The shorted DCP mode complies with BC1.2 and Chinese Telecommunications Industry Standard YD/T 1591-2009, whereas the divider3 and 1.2-V modes are employed to charge devices that do not comply with the BC1.2 DCP standard.

10.4.5.4.1 DCP BC1.2 and YD/T 1591-2009

Both standards specify that the D+ and D– data lines must be connected together with a maximum series impedance of 200 Ω , as shown in [Figure 10-32](#).

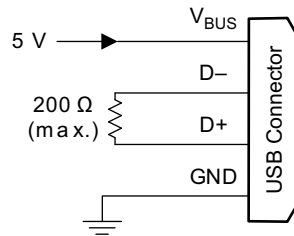

Figure 10-32. DCP Supporting BC1.2 and YD/T 1591-2009

10.4.5.4.2 DCP Divider-Charging Scheme

The device supports divider3, as shown in Figure 10-33. In the Divider3 charging scheme the device applies 2.7 V and 2.7 V to D+ and D– data lines.

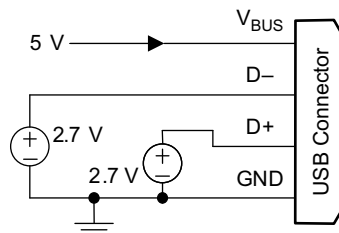

Figure 10-33. Divider 3 Mode

10.4.5.4.3 DCP 1.2-V Charging Scheme

The DCP 1.2-V charging scheme is used by some hand-held devices to enable fast charging at 2 A. The TPS25831-Q1 device supports this scheme in DCP-auto state before the device enters BC1.2 shorted mode. To simulate this charging scheme, the D+ and D– lines are shorted and pulled up to 1.2 V for a fixed duration. Then the device moves to DCP shorted mode as defined in the BC1.2 specification and as shown in Figure 10-34.

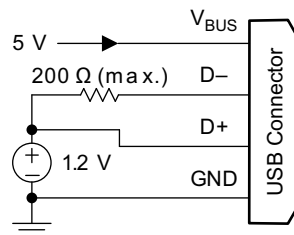

Figure 10-34. 1.2-V Mode

10.4.5.5 DCP Auto Mode (TPS25831-Q1 Only)

The TPS25831-Q1 device integrates an auto-detect state machine that supports all DCP charging schemes. The auto-detect state machine starts in the Divider3 scheme. If a BC1.2 or YD/T 1591-2009 compliant device is attached, the TPS25831-Q1 device briefly transitions to the 1.2-V mode before entering BC1.2 DCP mode. The auto-detect state machine stays in the 1.2 V or DCP mode until the connected device releases the data line, in which case the auto-detect state machine goes back to the Divider3 scheme. When a Divider3-compliant device is attached, the TPS25831-Q1 device stays in the Divider3 state.

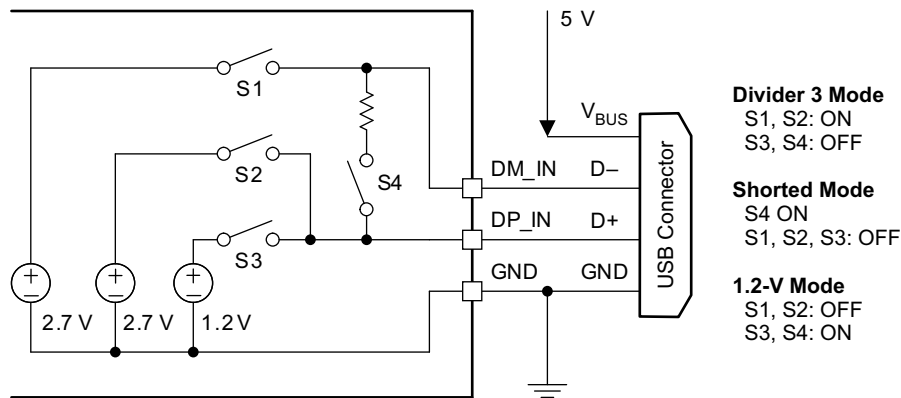

Figure 10-35. DCP Auto Mode

10.4.6 High-Bandwidth Data-Line Switches (TPS25830-Q1 only)

The TPS25830-Q1 device passes the DP and DM data lines through the device to enable monitoring and handshaking while supporting the charging operation. A wide-bandwidth signal switch allows data to pass through the device without corrupting signal integrity. The data-line switches are turned on in any of the CDP, SDP modes. The EN/UVLO input must be at logic high and UFP must be entered for the data line switches to be enabled.

For more detailed USB2.0 data line consideration and eye diagram test report, please refer to the [How to improve USB2.0 Eye Diagram using long USB cable application report](#).

Note

- While in CDP mode, the data switches are ON, even during CDP handshaking.
- The data line switches are OFF if EN/UVLO is low.
- The data line switches are OFF during External FET current limit conditions.
- The data line switches are not turned off during VCONN current-limit conditions.
- The data line switches are OFF if UFP mode is not entered.
- The data switches are only for a USB-2.0 differential pair. In the case of a USB-3.0 or 3.1 host, the super-speed differential pairs must be routed directly to the USB connector without passing through the TPS25830-Q1 device.

11 Application and Implementation

Note

Information in the following applications sections is not part of the TI component specification, and TI does not warrant its accuracy or completeness. TI's customers are responsible for determining suitability of components for their purposes, as well as validating and testing their design implementation to confirm system functionality.

11.1 Application Information

The TPS2583x-Q1 is a step down DC-to-DC regulator and USB charge port controller. It is typically used in automotive systems to convert a DC voltage from the vehicle battery to 5-V DC with a maximum output current of 3.5 A. The following design procedure can be used to select components for the TPS2583x-Q1.

11.2 Typical Application

The TPS2583x-Q1 only requires a few external components to convert from a wide voltage range supply to a 5-V output for powering USB devices. [Figure 11-1](#) shows a basic schematic.

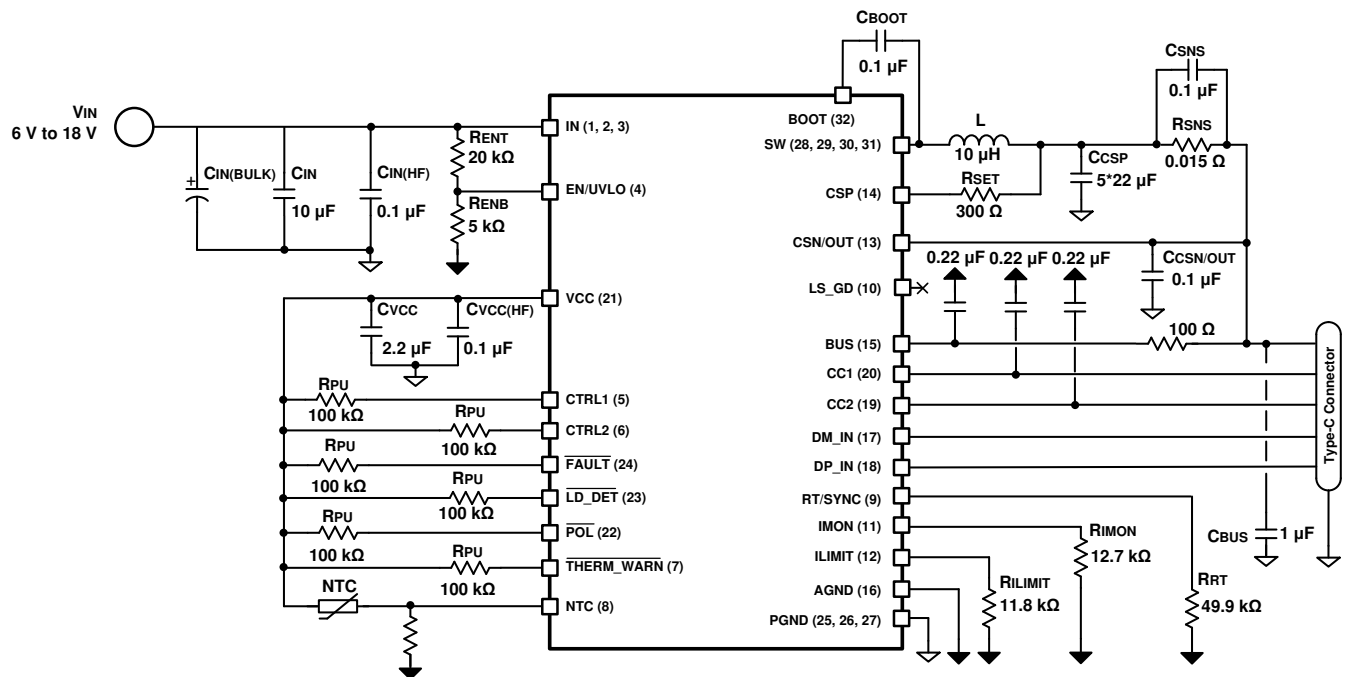

Figure 11-1. Application Circuit

The integrated buck regulator of TPS2583x-Q1 is internally compensated and optimized for a reasonable selection of external inductance and capacitance. The external components have to fulfill the needs of the application, but also the stability criteria of the device's control loop. [Table 11-2](#) can be used to simplify the output filter component selection.

11.2.1 Design Requirements

To begin the design process, a few parameters must be known:

- Cable compensation: Total resistance including cable resistance, contact resistance of connectors, TPS2583x-Q1 current sense resistor and external NFET $r_{DS(on)}$ (if used). Refer to [Figure 10-22](#) for examples of resistances in an automotive application.
- The maximum continuous output current for the charging port. The minimum current-limit setting of TPS2583x-Q1 device must be higher than this current.

For this example, use the parameters listed in [Table 11-1](#) as the input parameters.

Table 11-1. Design Example Parameters

PARAMETER	VALUE
Input Voltage, V_{IN}	13.5-V typical, range from 6 V to 18 V
Output Voltage, V_{OUT}	5.1 V
Maximum Output Current $I_{OUT(MAX)}$	3.0 A
Transient Response 0.3 A to 3 A	5%
Output Voltage Ripple	50 mV
Input Voltage Ripple	400 mV
Switching Frequency f_{SW}	400 kHz
Cable Resistance for Cable Compensation	300 m Ω
Current Limit by Buck Average	3.3 A

Table 11-2. L and C_{OUT} Typical Values

f_{SW}	V_{OUT} WITHOUT CABLE COMPENSATION	$C_{IN} + C_{HF}$	L	CURRENT LIMIT	C_{CSP}	$C_{CSN/OUT}$	C_{BUS}
400 kHz	5.10 V	$1 \times 10 \mu F + 1 \times 100 \text{ nF}$	10 μH	Buck Avg	$5 \times 22 \mu F$	100 nF	1 to 4.7 μF
400 kHz	5.10 V	$1 \times 10 \mu F + 1 \times 100 \text{ nF}$	10 μH	Ext. NFET	$5 \times 22 \mu F$	100 nF	1 to 4.7 μF
2100 kHz	5.10 V	$1 \times 10 \mu F + 1 \times 100 \text{ nF}$	2.2 μH	Buck Avg	$2 \times 22 \mu F$	100 nF	1 to 4.7 μF

1. Inductance value is calculated based on $V_{IN} = 18 \text{ V}$.
2. All the C_{OUT} values are after derating.

11.2.2 Detailed Design Procedure

11.2.2.1 Output Voltage

The output voltage of TPS2583x-Q1 is internally fixed at 5.10 V. Cable compensation can be used to increase the voltage on the CSN/OUT pin linearly with increasing load current. Refer to the [Cable Compensation](#) section for more details on output voltage variation versus load current. If cable compensation is not desired, use a 0 Ω R_{IMON} resistor.

11.2.2.2 Switching Frequency

The recommended switching frequency of the TPS2583x-Q1 is in the range of 300 to 400 kHz for best efficiency. Choose $R_{RT} = 49.9 \text{ k}\Omega$ for 400 kHz operation. To choose a different switching frequency, refer to [Table 10-1](#).

11.2.2.3 Inductor Selection

The most critical parameters for the inductor are the inductance, saturation current and the rated current. The inductance is based on the desired peak-to-peak ripple current Δi_L . Since the ripple current increases with the input voltage, the maximum input voltage is always used to calculate the minimum inductance L_{MIN} . Use [Equation 10](#) to calculate the minimum value of the output inductor. K_{IND} is a coefficient that represents the amount of inductor ripple current relative to the maximum output current of the device. A reasonable value of K_{IND} should be 20% to 40%. During an instantaneous short or overcurrent operation event, the RMS and peak inductor current can be high. The inductor current rating should be higher than the current limit of the device.

$$\Delta i_L = \frac{V_{OUT} \times (V_{IN_MAX} - V_{OUT})}{V_{IN_MAX} \times L \times f_{SW}} \quad (9)$$

$$L_{MIN} = \frac{V_{IN_MAX} - V_{OUT}}{I_{OUT} \times K_{IND}} \times \frac{V_{OUT}}{V_{IN_MAX} \times f_{SW}} \quad (10)$$

In general, it is preferable to choose lower inductance in switching power supplies, because it usually corresponds to faster transient response, smaller DCR, and reduced size for more compact designs. But too

low of an inductance can generate too large of an inductor current ripple such that overcurrent protection at the full load could be falsely triggered. Larger inductor current ripple also implies larger output voltage ripple with same output capacitors. With peak current mode control, it is not recommended to have too small of an inductor current ripple. A larger peak current ripple improves the comparator signal to noise ratio.

For this design example, choose $K_{IND} = 0.3$, the minimum inductor value is calculated to be 8.7 μH . Choose the nearest standard 10- μH ferrite inductor with a capability of 4-A RMS current and 6-A saturation current.

11.2.2.4 Output Capacitor Selection

The value of the output capacitor, and its ESR, determine the output voltage ripple and load transient performance. The output capacitor bank is usually limited by the load transient requirements, rather than the output voltage ripple. Equation 11 can be used to estimate a lower bound on the total output capacitance, and an upper bound on the ESR, required to meet a specified load transient.

$$C_{OUT} \geq \frac{\Delta I_{OUT}}{f_{SW} \cdot \Delta V_{OUT} \cdot K} \cdot \left[(1-D) \cdot (1+K) + \frac{K^2}{12} \cdot (2-D) \right]$$

$$ESR \leq \frac{(2+K) \cdot \Delta V_{OUT}}{2 \cdot \Delta I_{OUT} \left[1+K + \frac{K^2}{12} \cdot \left(1 + \frac{1}{(1-D)} \right) \right]}$$

$$D = \frac{V_{OUT}}{V_{IN}} \tag{11}$$

where

- ΔV_{OUT} = output voltage transient
- ΔI_{OUT} = output current transient
- K = Ripple factor from [Inductor Selection](#)

Once the output capacitor and ESR have been calculated, Equation 12 can be used to check the peak-to-peak output voltage ripple; V_r .

$$V_r \cong \Delta I_L \cdot \sqrt{ESR^2 + \frac{1}{(8 \cdot f_{SW} \cdot C_{OUT})^2}} \tag{12}$$

The output capacitor and ESR can then be adjusted to meet both the load transient and output ripple requirements.

For this example we require a ΔV_{OUT} of ≤ 250 mV for an output current step of $\Delta I_{OUT} = 2.7$ A. Equation 11 gives a minimum value of 86 μF and a maximum ESR of 0.08 Ω . Assuming a 20% tolerance and a 10% bias de-rating, we arrive at a minimum capacitance of 110 μF . This can be achieved with a bank of 5 \times 22- μF , 10-V, ceramic capacitors in the 1210 case size. More output capacitance can be used to improve the load transient response. Ceramic capacitors can easily meet the minimum ESR requirements. In some cases an aluminum electrolytic capacitor can be placed in parallel with the ceramics to help build up the required value of capacitance.

In practice the output capacitor has the most influence on the transient response and loop phase margin. Load transient testing and Bode plots are the best way to validate any given design and should always be completed before the application goes into production. In addition to the required output capacitance, a small ceramic placed on the output can help to reduce high frequency noise. Small case size ceramic capacitors in the range of 1 nF to 100 nF can be very helpful in reducing voltage spikes on the output caused by inductor and board parasitics.

The maximum value of total output capacitance should be limited to about 10 times the design value, or 1000 μF , whichever is smaller. Large values of output capacitance can adversely affect the start-up behavior of the

regulator as well as the loop stability. If values larger than noted here must be used, then a careful study of start-up at full load and loop stability must be performed.

11.2.2.5 Input Capacitor Selection

The TPS2583x-Q1 device requires high frequency input decoupling capacitor(s) and a bulk input capacitor, depending on the application. A high-quality ceramic capacitor type X5R or X7R with sufficient voltage ratings are recommended. To compensate the derating of ceramic capacitors, a voltage rating of twice the maximum input voltage is recommended. The bulk capacitance selection depends upon a number of factors: long leads from the automotive battery to the IN pin of TPS2583x-Q1, cold or warm engine crank requirements, etc. The bulk capacitor is used to dampen voltage spike due to the lead inductance of the cable or the trace. For this design, one 10 μ F, 50 V, X7R ceramic capacitors are used. A 0.1 μ F for high-frequency filtering and place it as close as possible to the device pins. Consider adding additional bulk capacitance for operation through low V_{IN} warm-crank profiles is required by the vehicle OEM.

11.2.2.6 Bootstrap Capacitor Selection

Every TPS2583x-Q1 design requires a bootstrap capacitor (C_{BOOT}). The recommended capacitor is 0.1 μ F and rated 10 V or higher. The bootstrap capacitor is located between the SW pin and the BOOT pin. The bootstrap capacitor must be a high-quality ceramic type with an X7R or X5R grade dielectric for temperature stability.

11.2.2.7 VCC Capacitor Selection

The VCC pin is the output of an internal LDO for TPS2583x. The LDO supplies gate charge to the LS buck switch and is the supply to the digital state-machine and analog USB circuitry. To insure stability of the device, place a minimum of 2.2 μ F, 10 V, X7R capacitor from this pin to ground. In addition a 0.1- μ F high frequency decoupling capacitor is highly recommended.

11.2.2.8 Enable and Undervoltage Lockout Set-Point

The system enable and undervoltage lockout (UVLO) is adjusted using the external voltage divider network of R_{ENT} and R_{ENB} . The EN/UVLO has two thresholds, one for power up when the input voltage is rising and one for power down or brown outs when the input voltage is falling. The following equations can be used to determine the $V_{IN(ON)}$ and $V_{IN(OFF)}$ levels.

$$R_{ENT} = \left(\frac{V_{IN(ON)}}{V_{EN/UVLO_H}} - 1 \right) \times R_{ENB} \quad (13)$$

$$V_{IN(OFF)} = V_{IN(ON)} \times \left(1 - \frac{V_{EN/UVLO_HYS}}{V_{EN/UVLO_H}} \right) \quad (14)$$

$V_{IN(ON)} = 6$ V (user choice)

$R_{ENB} = 5$ k Ω (user choice)

$R_{ENT} = [(V_{IN(ON)} / V_{EN/UVLO_H}) - 1] \times R_{ENB}$

$R_{ENT} = [(6 \text{ V} / 1.2 \text{ V}) - 1] \times 5 \text{ k}\Omega = 20 \text{ k}\Omega$. Choose standard 20 k Ω .

Therefore $V_{IN(OFF)} = 6 \text{ V} \times [1 - (0.09 \text{ V} / 1.2 \text{ V})] = 5.55 \text{ V}$

11.2.2.9 Current Limit Set-Point

The TPS2583x-Q1 can provide an accurate current limit to protect the USB port from overload based upon the values of R_{SNS} , R_{SET} and R_{LIMIT} . The design process is the same regardless of whether buck average current limiting or external NFET current limiting is chosen. The only difference is the current limit threshold voltage on the ILIMIT pin.

- R_{SNS} is the current sense resistor. The recommended voltage across the R_{SNS} undercurrent limit should be approximately 50 mV as a compromise between accuracy and power dissipation. For example, if current

limiting is desired for $I_{OUT(MAX)} \geq 3.3 \text{ A}$, then $R_{SNS} = 0.05 \text{ V} / 3.3 \text{ A} = 0.01515 \Omega$. Choose a standard value of 15 mΩ.

- R_{SET} determines the input current to the transconductance amplifier and current mirror. The amplifier balances the voltage to be equal to that across R_{SNS} . Choose a R_{SET} value to produce an I_{SET} current between 75 - 180 μA at the desired $I_{OUT(MAX)}$. Considering 50 mV across R_{SET} , a value of 300 Ω will provide approximately 166 μA of I_{SET} current to the amplifier and mirror circuit. Care should be taken to limit the I_{SET} current below 200 μA to avoid saturating the internal amplifier circuit.
- Buck average current limiting occurs when $V_{ILIMIT} = 1 \text{ V}$. R_{ILIMIT} is calculated as $1 \text{ V} \times 300 \Omega / [0.5 \times (3.3 \text{ A} \times 15 \text{ m}\Omega + 0.7 \text{ mV})] = 11.95 \text{ k}\Omega$. A standard 11.8 kΩ value is chosen.

11.2.2.10 Cable Compensation Set-Point

From [Table 11-1](#) the total cable resistance to be accounted for is 300 mΩ.

1. From [Current Limit Set-Point](#) R_{SNS} and R_{SET} have been determined as 15 mΩ and 300 Ω, respectively.
2. $R_{WIRE} = 300 \text{ m}\Omega$
3. $\Delta V_{OUT} = (R_{SNS} + R_{WIRE}) \times I_{BUS} = (0.015 + 0.3) \times 3 = 1.0395 \text{ V}$
4. $R_{IMON} = (\Delta V_{OUT} \times R_{SET} \times 2) / (I_{BUS} \times R_{SNS}) = (1.0395 \times 300 \times 2) / (3.3 \times 0.015) = 12.6 \text{ k}\Omega$. A standard value of 12.7 kΩ is selected.

11.2.2.11 $\overline{LD_DET}$, \overline{POL} , and \overline{FAULT} Resistor Selection

The $\overline{LD_DET}$, \overline{POL} , and \overline{FAULT} pins are open-drain output flags. They can be connected to the TPS2583x-Q1 VCC pin with 100-kΩ resistors, or connected to another suitable I/O voltage supply if actively monitored by a USB HUB or MCU. They can be left floating if unused.

11.2.3 Application Curves

Unless otherwise specified the following conditions apply: $V_{IN} = 13.5\text{ V}$, $f_{SW} = 400\text{ kHz}$, $L = 10\text{ }\mu\text{H}$, $C_{OUT_CSP} = 66\text{ }\mu\text{F}$, $C_{OUT_CSN} = 0.1\text{ }\mu\text{F}$, $C_{BUS} = 1\text{ }\mu\text{F}$, $T_A = 25\text{ }^\circ\text{C}$.

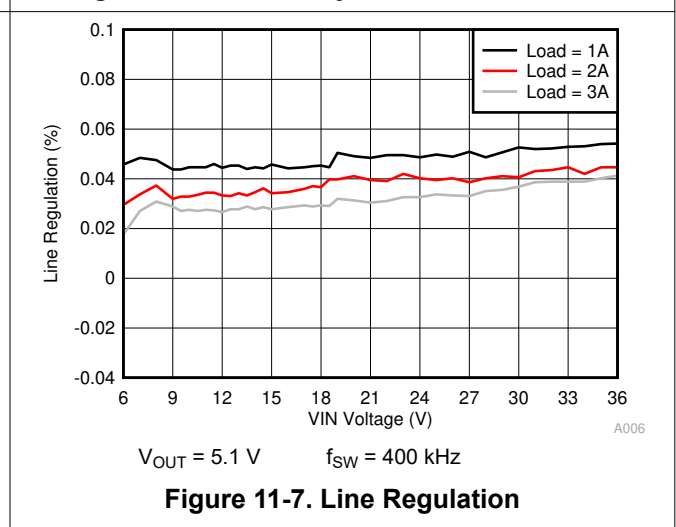
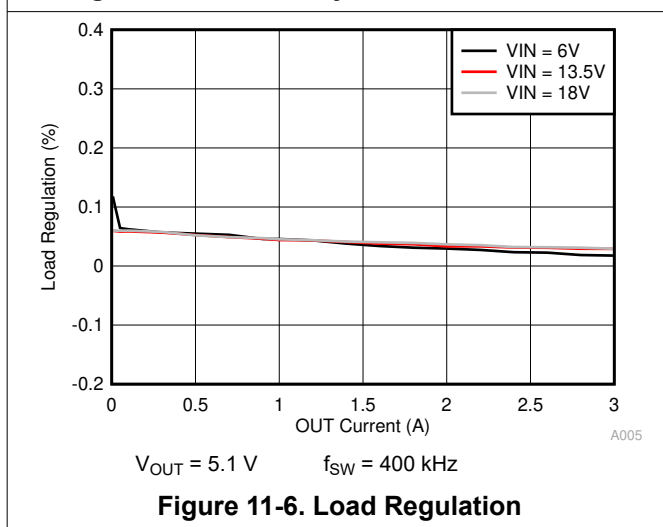
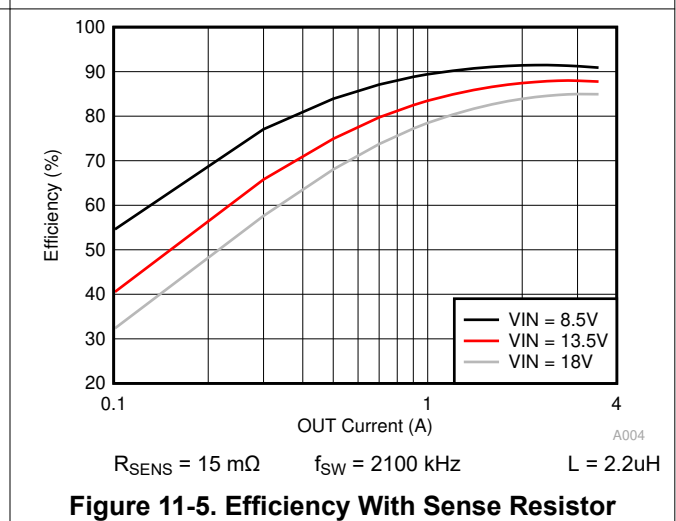
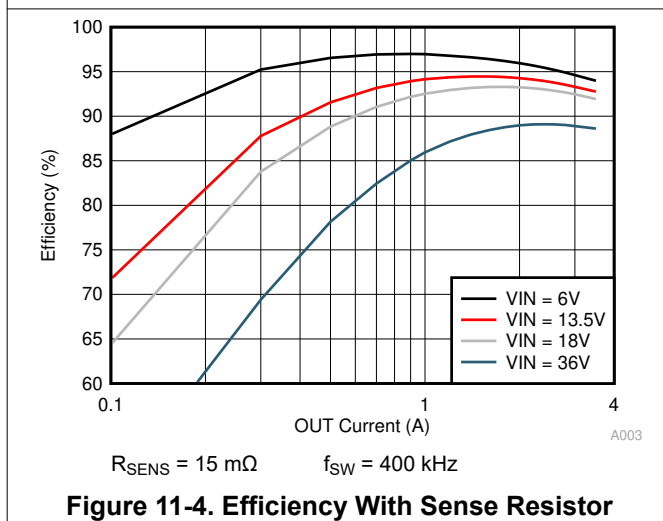
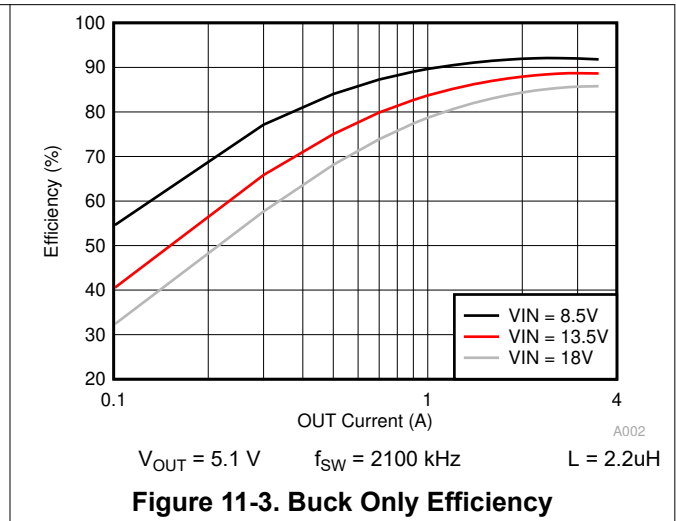
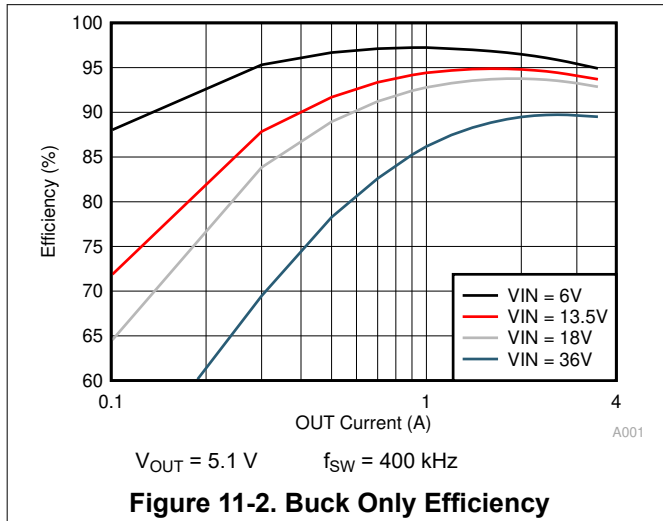

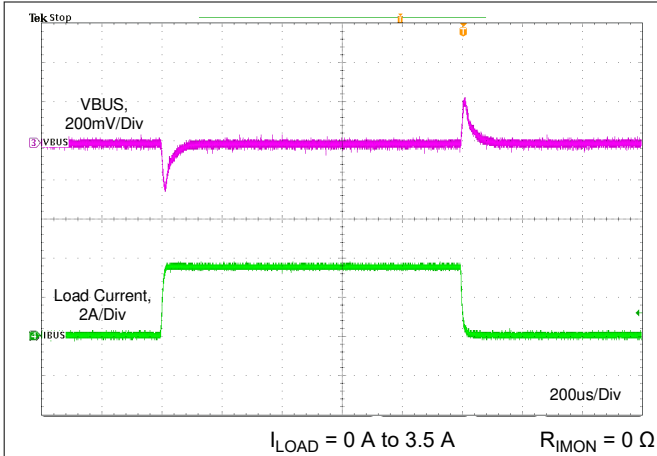

Figure 11-8. Load Transient Without Cable Compensation

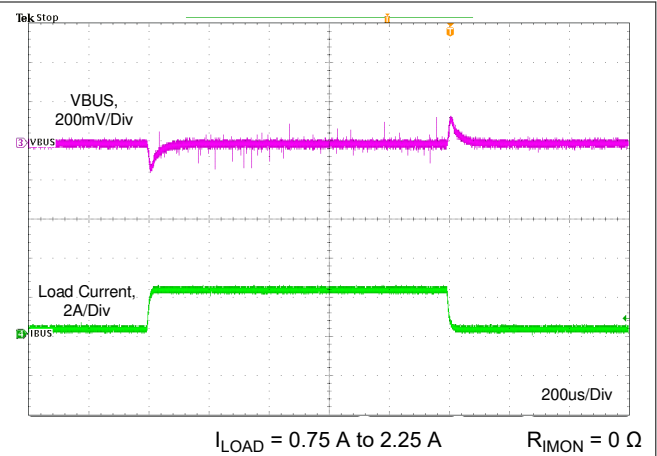

Figure 11-9. Load Transient Without Cable Compensation

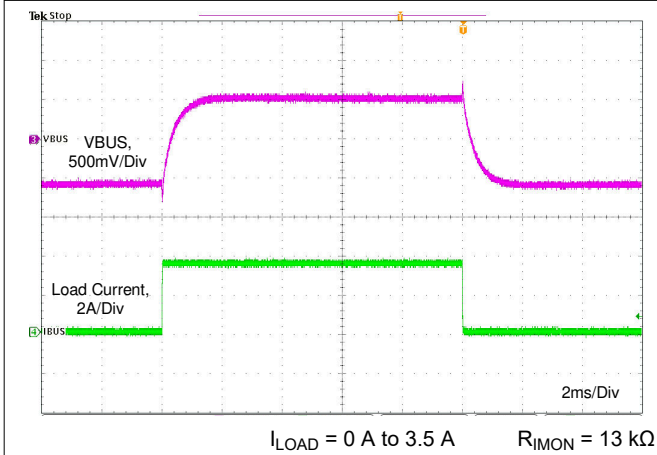

Figure 11-10. Load Transient With Cable Compensation

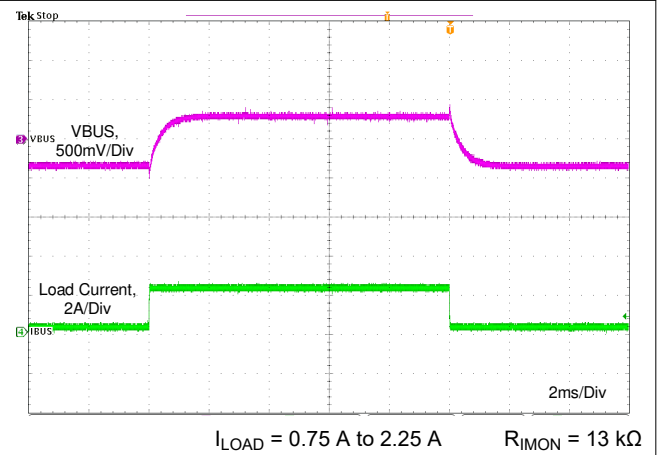

Figure 11-11. Load Transient With Cable Compensation

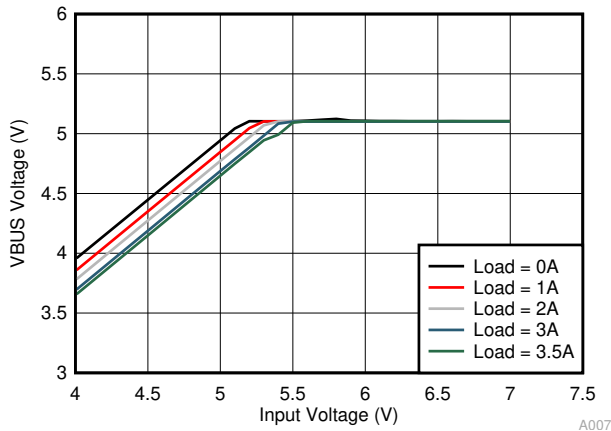

Figure 11-12. Dropout Characteristic

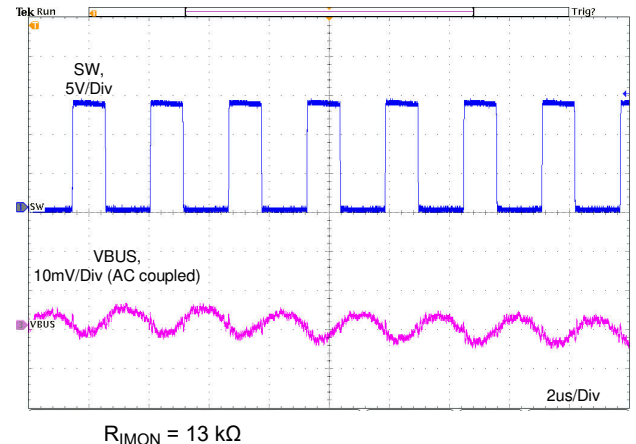
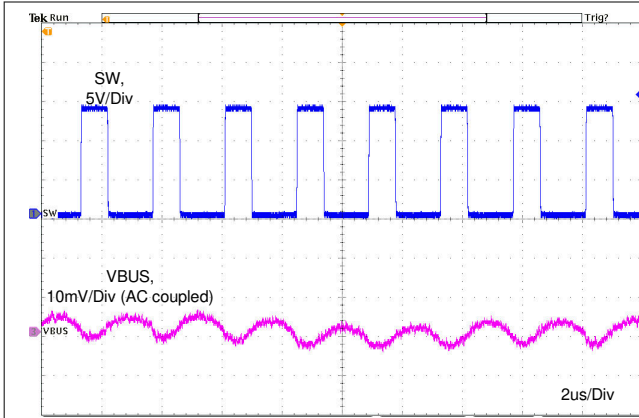
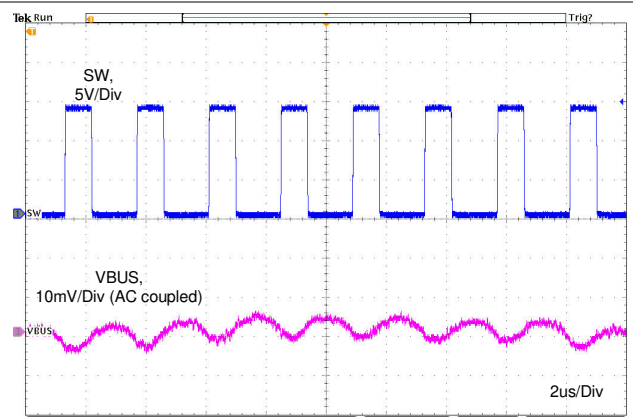

Figure 11-13. 3.5-A Output Ripple



$R_{IMON} = 13\text{ k}\Omega$
Figure 11-14. 100-mA Output Ripple



$R_{IMON} = 13\text{ k}\Omega$
Figure 11-15. No Load Output Ripple

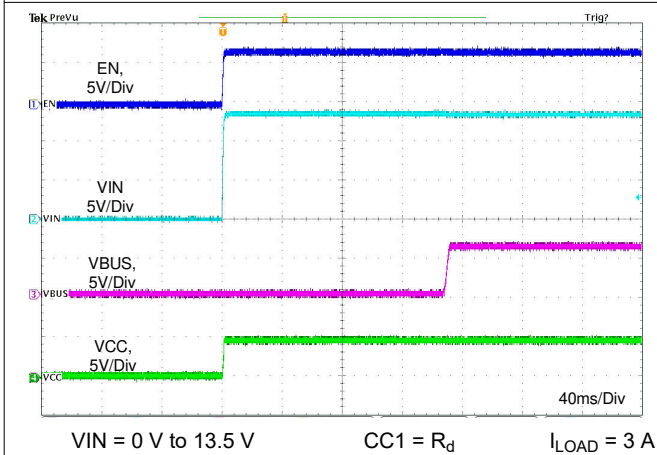

$VIN = 0\text{ V to }13.5\text{ V}$ $CC1 = R_d$ $I_{LOAD} = 3\text{ A}$
Figure 11-16. Startup Relate to VIN

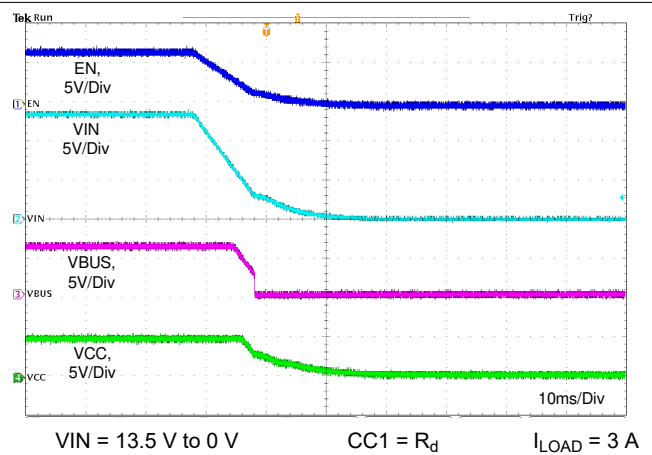

$VIN = 13.5\text{ V to }0\text{ V}$ $CC1 = R_d$ $I_{LOAD} = 3\text{ A}$
Figure 11-17. Shutdown Relate to VIN

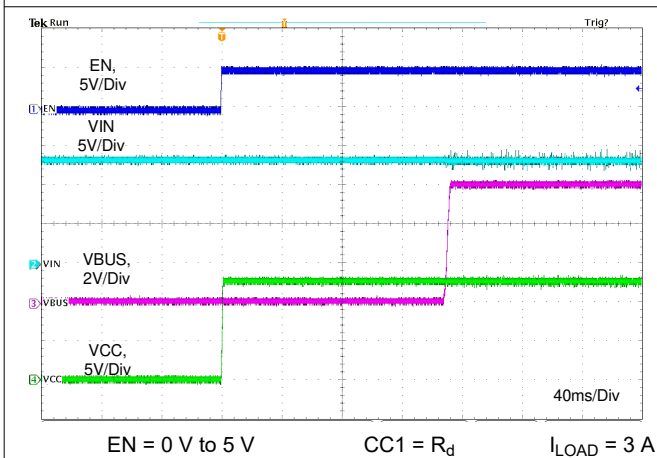

$EN = 0\text{ V to }5\text{ V}$ $CC1 = R_d$ $I_{LOAD} = 3\text{ A}$
Figure 11-18. Startup Relate to EN

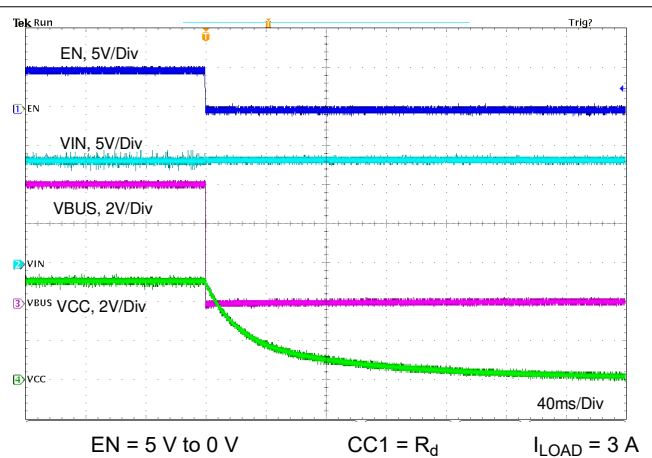

$EN = 5\text{ V to }0\text{ V}$ $CC1 = R_d$ $I_{LOAD} = 3\text{ A}$
Figure 11-19. Shutdown Relate to EN

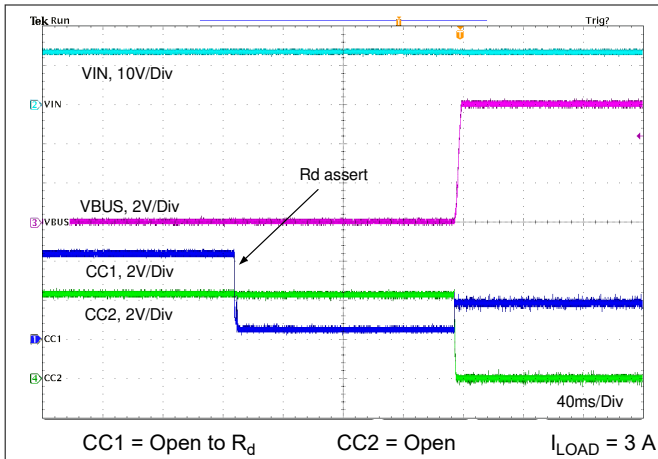

Figure 11-20. Rd Assert

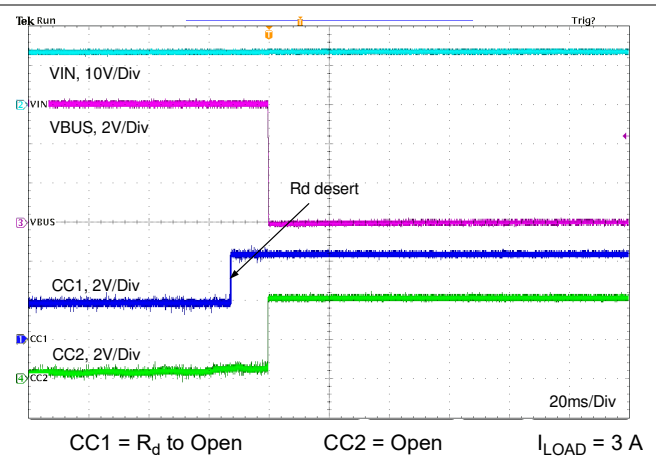

Figure 11-21. Rd Desert

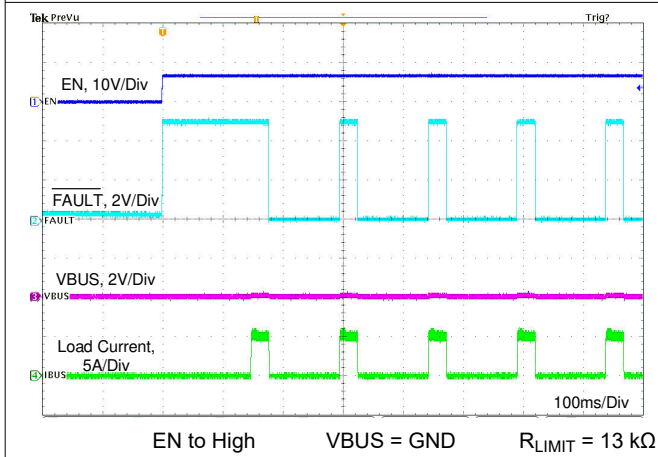

Figure 11-22. Enable Into Short Without External FET

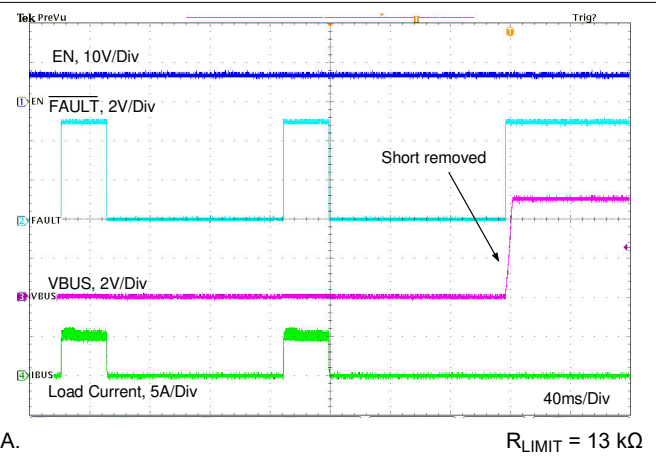

Figure 11-23. Short Circuit Recovery Without External FET

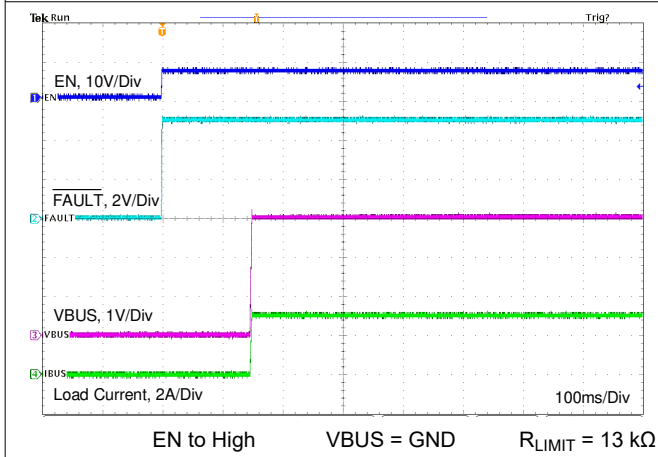

Figure 11-24. Enable into 1-Ω Load Without External FET

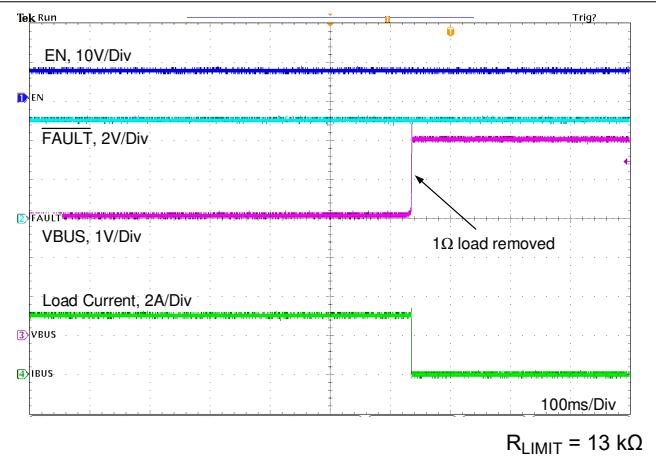

Figure 11-25. 1-Ω Load Recovery Without External FET

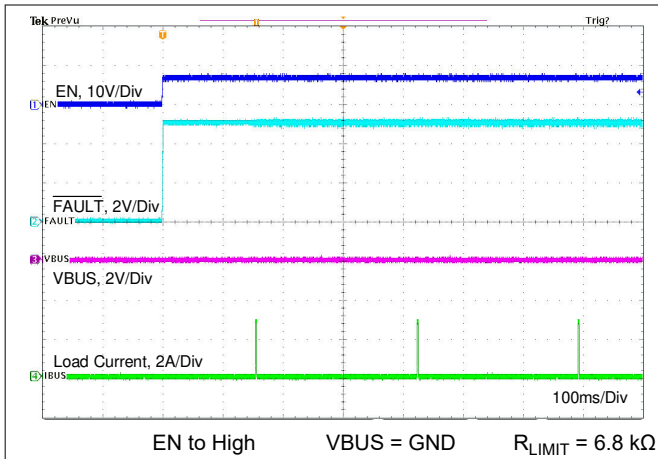

Figure 11-26. Enable Into Short With External FET

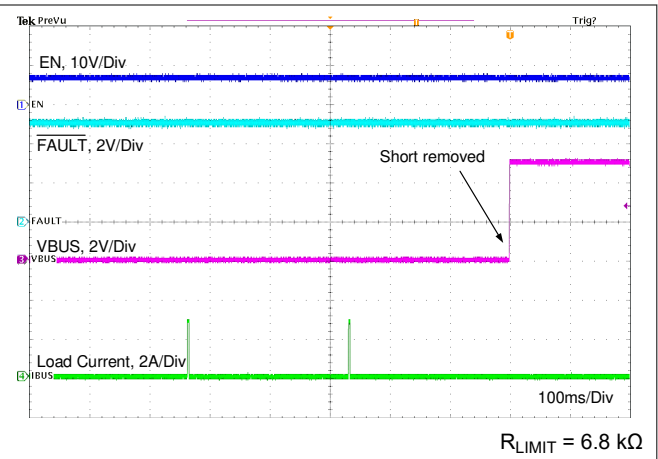

Figure 11-27. Short Circuit Recovery With External FET

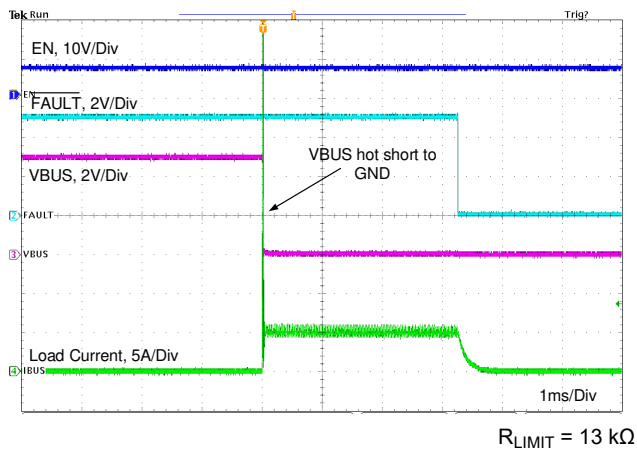

Figure 11-28. VBUS Hot Short to GND Without External FET

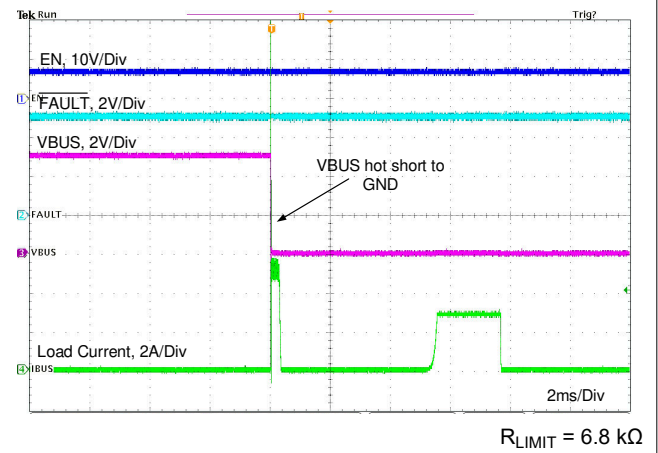

Figure 11-29. VBUS Hot Short to GND With External FET

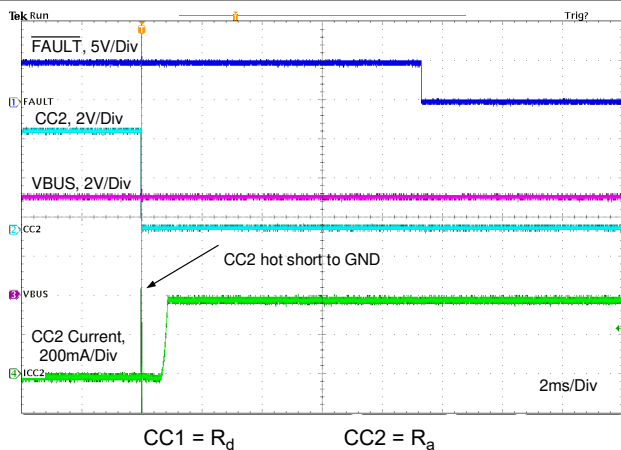

Figure 11-30. CC2 Hot Short to GND

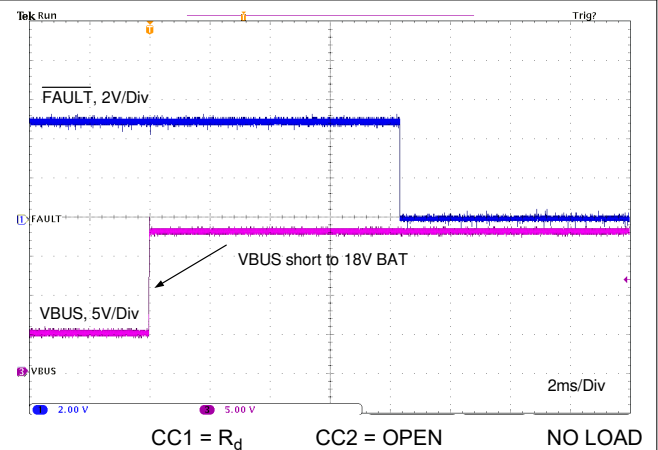

Figure 11-31. VBUS Short to BAT With External FET

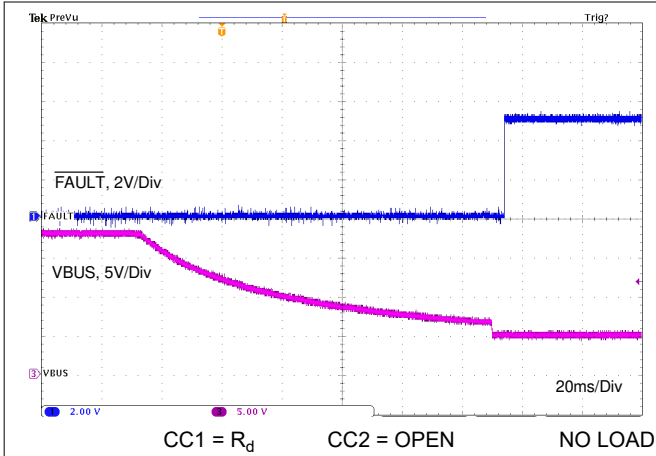

Figure 11-32. VBUS Short to BAT Recovery With External FET

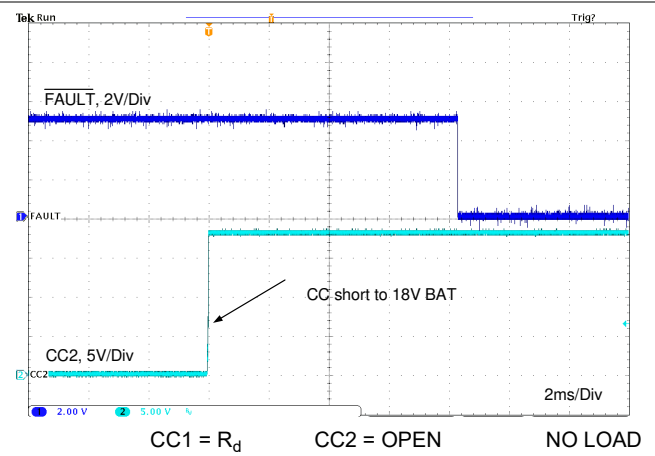

Figure 11-33. CC Short to BAT

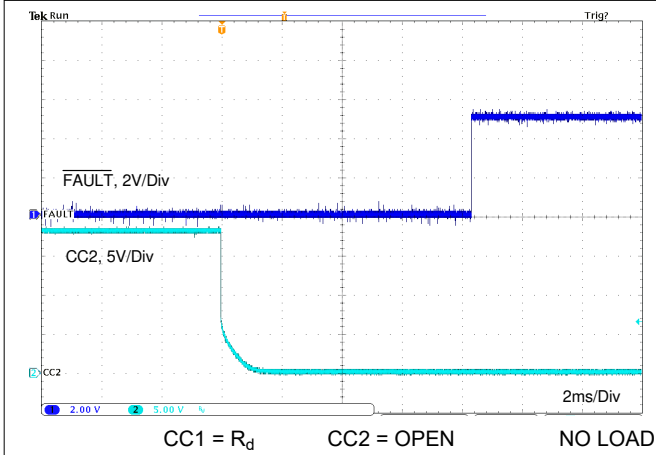

Figure 11-34. CC Short to BAT Recovery

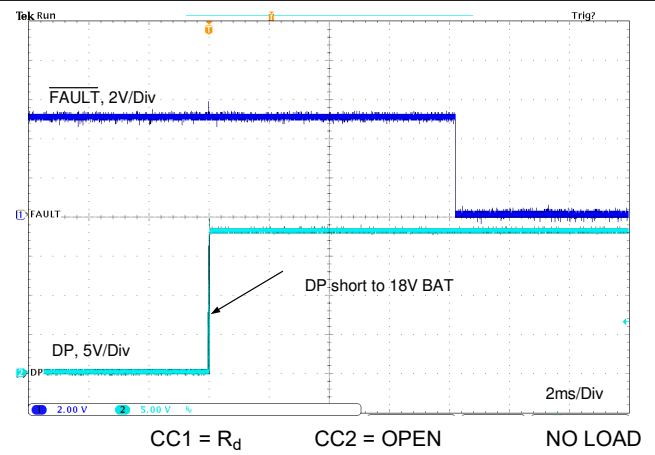

Figure 11-35. DP Short to BAT

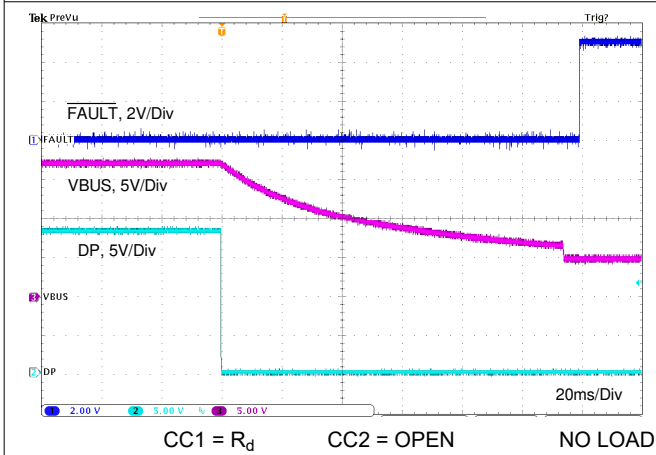

Figure 11-36. DP Short to BAT Recovery

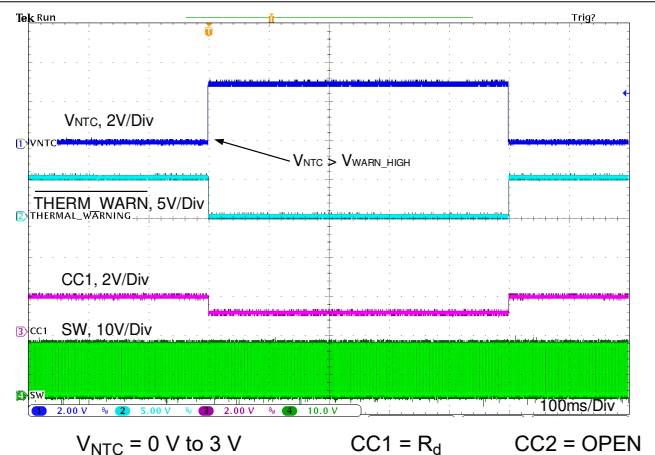
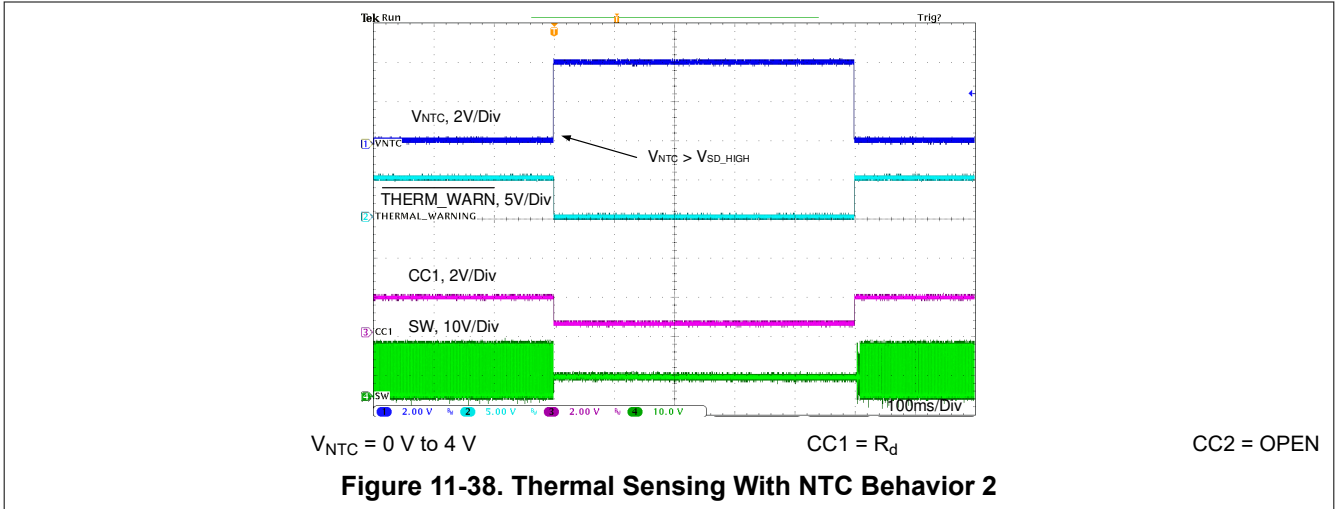

Figure 11-37. Thermal Sensing With NTC Behavior

1



12 Power Supply Recommendations

The TPS2583x-Q1 is designed to operate from an input voltage supply range between 6 V and 36 V. This input supply should be able to withstand the maximum input current and maintain a stable voltage. The resistance of the input supply rail should be low enough that an input current transient does not cause a high enough drop at the TPS2583x-Q1 supply voltage that can cause a false UVLO fault triggering and system reset. If the input supply is located more than a few inches from the TPS2583x, additional bulk capacitance may be required in addition to the ceramic input capacitors. The amount of bulk capacitance is not critical, but a 47- μ F or 100- μ F electrolytic capacitor is a typical choice.

13 Layout

13.1 Layout Guidelines

Layout is a critical portion of good power supply design. The following guidelines will help users design a PCB with the best power conversion performance, thermal performance, and minimized generation of unwanted EMI. For more detailed EMC design consideration and test report, please refer to the [PCB Layout and Parameters Recommendation for TPS2583X EMC Performance application report](#).

1. **Input capacitor:** The input bypass capacitor C_{IN} must be placed as close as possible to the IN and PGND pins. Grounding for both the input and output capacitors should consist of localized top side planes that connect to the PGND pin and PAD. A combination of different values and packages of capacitors can help improve the EMC performance (for example: 10 μ F + 0.1 μ F + 2.2nF). Besides, the distance between the input filter section and the output power section must be at least 15mm to prevent the output high-frequency signal from coupling into the input filter. A 10 μ F cap cross V_{IN} and PGND pin on top of SW is suggested for TPS2583x-Q1.
2. **V_{CC} bypass capacitor:** Place bypass capacitors for V_{CC} close to the VCC pin and ground the bypass capacitor to device ground.
3. Use a ground plane in one of the middle layers as noise shielding and heat dissipation path.
4. Connect the thermal pad to the ground plane. The QFN package has a thermal pad (PAD) connection that must be soldered down to the PCB ground plane. This pad acts as a heat-sink connection. The integrity of this solder connection has a direct bearing on the total effective $R_{\theta JA}$ of the application.
5. Make V_{IN} , V_{OUT} and ground bus connections as wide as possible. This reduces any voltage drops on the input or output paths of the converter and maximizes efficiency.
6. Provide enough PCB area for proper heat sinking. As stated in the section, enough copper area must be used to ensure a low $R_{\theta JA}$, commensurate with the maximum load current and ambient temperature. Make the top and bottom PCB layers with two-ounce copper; and no less than one ounce. Use an array of heat-sinking vias to connect the thermal pad (PAD) to the ground plane on the bottom PCB layer. If the PCB design uses multiple copper layers (recommended), thermal vias can also be connected to the inner layer heat-spreading ground planes.
7. The SW pin connecting to the inductor should be as short as possible, and just wide enough to carry the load current without excessive heating. Short, thick traces or copper pours (shapes) will bring a high current conduction capacity to minimize parasitic resistance, but it will also cause a larger parasitic capacitance. Thus a balance should be found between smaller parasitic resistance and larger parasitic capacitance. And the current path should be kept straight forward to the inductor, otherwise the L-shaped or T-shaped path will make a sudden change of the impedance which causes signal reflection and impacts the performance of EMC. The output capacitors should be placed close to the V_{OUT} end of the inductor and closely grounded to PGND pin and exposed PAD. Besides, do not punch vias on SW lines. Using shielded inductors or molded inductors to reduce high-frequency radiation.
8. **Sense and Set Resistors:** The R_{SNS} and R_{SET} resistors connect to the current sense amplifier inputs at the CSP and CSN/OUT pins. For best current limit and cable compensation accuracy; short, parallel traces give the best performance. If it is not possible to place R_{SNS} and R_{SET} near the CSP and CSN/OUT pins, it is recommended that the traces from sense resistor be routed in parallel and of similar lengths. A small filter capacitor in parallel with R_{SNS} and a small filter capacitor from CSN/OUT to AGND help decouple noise.
9. R_{LIMIT} and R_{IMON} resistors should be placed as close as possible to the ILIMIT and IMON pins and connected to AGND. If needed, these components can be placed on the bottom side of the PCB with signals routed through small vias.

10. Trace routing of DP_IN, DM_IN, DP_OUT, and DM_OUT: Route these traces as micro-strips with nominal differential impedance of 90 Ω. Minimize the use of vias in the high-speed data lines. Keep the reference GND plane devoid from cuts or splits above the differential pairs to prevent impedance discontinuities.
11. Keep the CC lines close to the same length. Do not create stubs or test points on the CC lines.
12. POL, LD_DET, FAULT and THERM_WARN (TPS25831-Q1) are open-drain outputs. They can be connected to the VCC pin via pull-up resistors. Suggested resistor value is 100 kΩ.
13. The area enclosed by current loop of input side and output side should be as small as possible; the area enclosed by the BOOT circuit should be as small as possible.
14. Power ground PGND and the signal ground AGND should be separated in the actual PCB layout.

13.2 Ground Plane and Thermal Considerations

It is recommended to use one of the middle layers as a solid ground plane. Ground plane provides shielding for sensitive circuits and traces. It also provides a quiet reference potential for the control circuitry. The PGND pins should be connected to the ground plane using vias right next to the bypass capacitors. PGND pin is connected to the source of the internal LS switch. The PGND net contains noise at switching frequency and may bounce due to load variations. PGND trace, as well as VIN and SW traces, should be constrained to one side of the ground plane. The other side of the ground plane contains much less noise and should be used for sensitive routes. AGND and PGND should be connected under the QFN package PAD.

It is recommended to provide adequate device heat sinking by utilizing the PAD of the IC as the primary thermal path. Use a minimum 2 row, 2 column "+" array of 12 mil thermal vias to connect the PAD to the system ground plane heat sink. The vias should be evenly distributed under the PAD. Use as much copper as possible, for system ground plane, on the top and bottom layers for the best heat dissipation. Use a four-layer board with the copper thickness for the four layers, starting from the top of, 2 oz / 1 oz / 1 oz / 2 oz. Four layer boards with enough copper thickness provide low current conduction impedance, proper shielding and lower thermal resistance.

The thermal characteristics of the TPS2583x-Q1 are specified using the parameter θ_{JA} , which characterize the junction temperature of silicon to the ambient temperature in a specific system. Although the value of θ_{JA} is dependent on many variables, it still can be used to approximate the operating junction temperature of the device. To obtain an estimate of the device junction temperature, one may use the following relationship:

$$T_J = P_D \times \theta_{JA} + T_A \quad (15)$$

where

T_J = Junction temperature in °C

$P_D = V_{IN} \times I_{IN} \times (1 - \text{Efficiency}) - 1.1 \times I_{OUT}^2 \times \text{DCR}$ in Watt

DCR = Inductor DC parasitic resistance in Ω

θ_{JA} = Junction to ambient thermal resistance of the device in °C/W

T_A = Ambient temperature in °C

θ_{JA} is highly related to PCB size and layout, as well as environmental factors such as heat sinking and air flow.

13.3 Layout Example

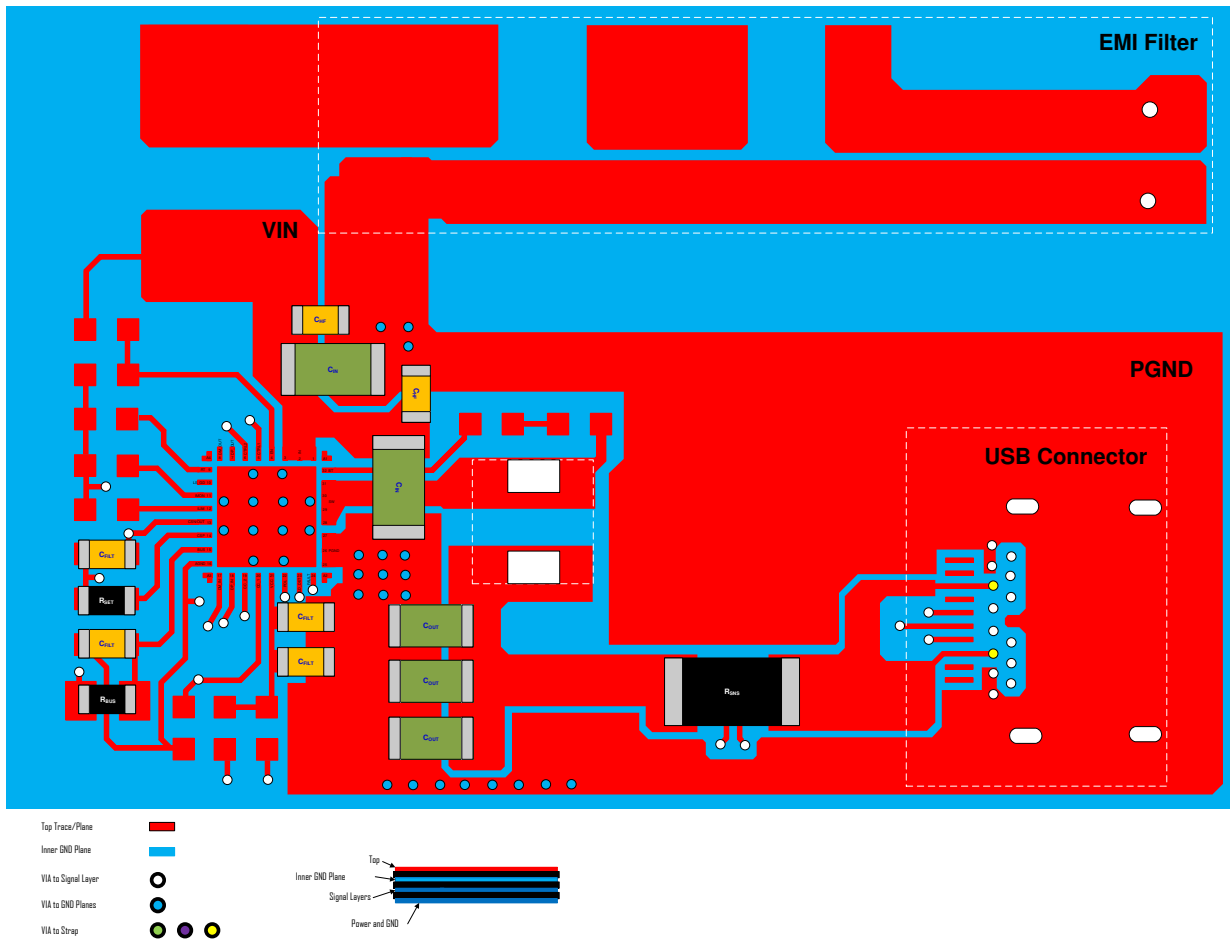

Figure 13-1. Layout

14 Device and Documentation Support

14.1 Documentation Support

14.1.1 Related Documentation

- Texas Instruments, [How to Pass MFi Overcurrent Protection Test With USB Charger and Switch Device application report](#)
- Texas Instruments, [TPS2583x-Q1 and TPS2584x-Q1 Short-to-Battery Application application report](#)
- Texas Instruments, [How to improve USB2.0 Eye Diagram using long USB cable application report](#)
- Texas Instruments, [PCB Layout and Parameters Recommendation for TPS2583X EMC Performance application report](#)

14.2 Related Links

The table below lists quick access links. Categories include technical documents, support and community resources, tools and software, and quick access to sample or buy.

Table 14-1. Related Links

PARTS	PRODUCT FOLDER	ORDER NOW	TECHNICAL DOCUMENTS	TOOLS & SOFTWARE	SUPPORT & COMMUNITY
TPS25830-Q1	Click here	Click here	Click here	Click here	Click here
TPS25831-Q1	Click here	Click here	Click here	Click here	Click here

14.3 Receiving Notification of Documentation Updates

To receive notification of documentation updates, navigate to the device product folder on [ti.com](#). Click on *Subscribe to updates* to register and receive a weekly digest of any product information that has changed. For change details, review the revision history included in any revised document.

14.4 Support Resources

[TI E2E™ support forums](#) are an engineer's go-to source for fast, verified answers and design help — straight from the experts. Search existing answers or ask your own question to get the quick design help you need.

Linked content is provided "AS IS" by the respective contributors. They do not constitute TI specifications and do not necessarily reflect TI's views; see TI's [Terms of Use](#).

14.5 Trademarks

TI E2E™ is a trademark of Texas Instruments.

USB Type-C® is a registered trademark of USB Implementers Forum.

All trademarks are the property of their respective owners.

14.6 Electrostatic Discharge Caution



This integrated circuit can be damaged by ESD. Texas Instruments recommends that all integrated circuits be handled with appropriate precautions. Failure to observe proper handling and installation procedures can cause damage.

ESD damage can range from subtle performance degradation to complete device failure. Precision integrated circuits may be more susceptible to damage because very small parametric changes could cause the device not to meet its published specifications.

14.7 Glossary

[TI Glossary](#) This glossary lists and explains terms, acronyms, and definitions.

15 Mechanical, Packaging, and Orderable Information

The following pages include mechanical, packaging, and orderable information. This information is the most current data available for the designated devices. This data is subject to change without notice and revision of this document. For browser-based versions of this data sheet, refer to the left-hand navigation.

PACKAGING INFORMATION

Orderable Device	Status (1)	Package Type	Package Drawing	Pins	Package Qty	Eco Plan (2)	Lead finish/ Ball material (6)	MSL Peak Temp (3)	Op Temp (°C)	Device Marking (4/5)	Samples
TPS25830QCWRHBRQ1	ACTIVE	VQFN	RHB	32	5000	RoHS & Green	NIPDAU	Level-2-260C-1 YEAR	-40 to 125	T25830	Samples
TPS25830QWRHBRQ1	ACTIVE	VQFN	RHB	32	3000	RoHS & Green	SN	Level-2-260C-1 YEAR	-40 to 125	T25830	Samples
TPS25830QWRHBTQ1	ACTIVE	VQFN	RHB	32	250	RoHS & Green	SN	Level-2-260C-1 YEAR	-40 to 125	T25830	Samples
TPS25831QCWRHBRQ1	ACTIVE	VQFN	RHB	32	5000	RoHS & Green	NIPDAU	Level-2-260C-1 YEAR	-40 to 125	T25831	Samples
TPS25831QWRHBRQ1	ACTIVE	VQFN	RHB	32	3000	RoHS & Green	SN	Level-2-260C-1 YEAR	-40 to 125	T25831	Samples
TPS25831QWRHBTQ1	ACTIVE	VQFN	RHB	32	250	RoHS & Green	SN	Level-2-260C-1 YEAR	-40 to 125	T25831	Samples

(1) The marketing status values are defined as follows:

ACTIVE: Product device recommended for new designs.

LIFEBUY: TI has announced that the device will be discontinued, and a lifetime-buy period is in effect.

NRND: Not recommended for new designs. Device is in production to support existing customers, but TI does not recommend using this part in a new design.

PREVIEW: Device has been announced but is not in production. Samples may or may not be available.

OBSOLETE: TI has discontinued the production of the device.

(2) **RoHS:** TI defines "RoHS" to mean semiconductor products that are compliant with the current EU RoHS requirements for all 10 RoHS substances, including the requirement that RoHS substance do not exceed 0.1% by weight in homogeneous materials. Where designed to be soldered at high temperatures, "RoHS" products are suitable for use in specified lead-free processes. TI may reference these types of products as "Pb-Free".

RoHS Exempt: TI defines "RoHS Exempt" to mean products that contain lead but are compliant with EU RoHS pursuant to a specific EU RoHS exemption.

Green: TI defines "Green" to mean the content of Chlorine (Cl) and Bromine (Br) based flame retardants meet JS709B low halogen requirements of <=1000ppm threshold. Antimony trioxide based flame retardants must also meet the <=1000ppm threshold requirement.

(3) MSL, Peak Temp. - The Moisture Sensitivity Level rating according to the JEDEC industry standard classifications, and peak solder temperature.

(4) There may be additional marking, which relates to the logo, the lot trace code information, or the environmental category on the device.

(5) Multiple Device Markings will be inside parentheses. Only one Device Marking contained in parentheses and separated by a "~" will appear on a device. If a line is indented then it is a continuation of the previous line and the two combined represent the entire Device Marking for that device.

(6) Lead finish/Ball material - Orderable Devices may have multiple material finish options. Finish options are separated by a vertical ruled line. Lead finish/Ball material values may wrap to two lines if the finish value exceeds the maximum column width.

Important Information and Disclaimer: The information provided on this page represents TI's knowledge and belief as of the date that it is provided. TI bases its knowledge and belief on information provided by third parties, and makes no representation or warranty as to the accuracy of such information. Efforts are underway to better integrate information from third parties. TI has taken and continues to take reasonable steps to provide representative and accurate information but may not have conducted destructive testing or chemical analysis on incoming materials and chemicals. TI and TI suppliers consider certain information to be proprietary, and thus CAS numbers and other limited information may not be available for release.

In no event shall TI's liability arising out of such information exceed the total purchase price of the TI part(s) at issue in this document sold by TI to Customer on an annual basis.

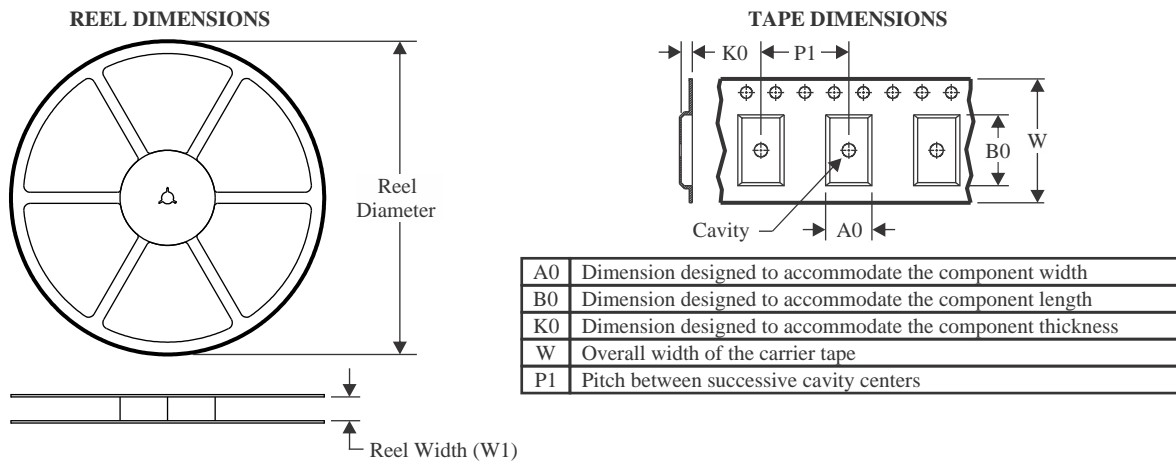
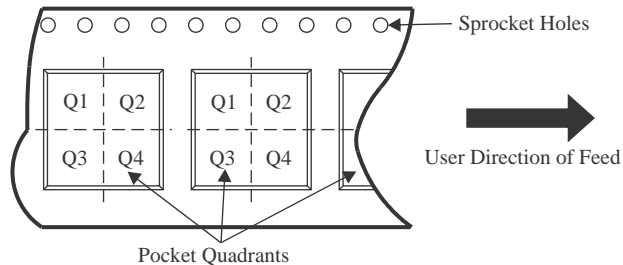
TAPE AND REEL INFORMATION

QUADRANT ASSIGNMENTS FOR PIN 1 ORIENTATION IN TAPE

*All dimensions are nominal

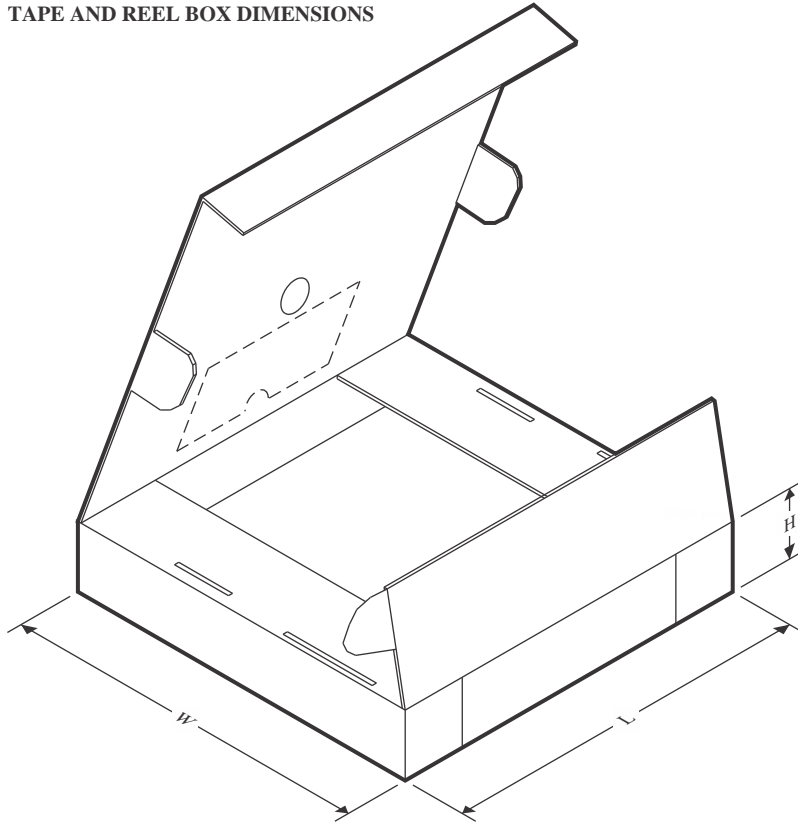
Device	Package Type	Package Drawing	Pins	SPQ	Reel Diameter (mm)	Reel Width W1 (mm)	A0 (mm)	B0 (mm)	K0 (mm)	P1 (mm)	W (mm)	Pin1 Quadrant
TPS25830QCWRHBRQ1	VQFN	RHB	32	5000	330.0	12.4	5.3	5.3	1.1	8.0	12.0	Q2
TPS25830QWRHBRQ1	VQFN	RHB	32	3000	330.0	12.4	5.25	5.25	1.1	8.0	12.0	Q2
TPS25830QWRHBTQ1	VQFN	RHB	32	250	180.0	12.4	5.25	5.25	1.1	8.0	12.0	Q2
TPS25831QCWRHBRQ1	VQFN	RHB	32	5000	330.0	12.4	5.3	5.3	1.1	8.0	12.0	Q2
TPS25831QWRHBRQ1	VQFN	RHB	32	3000	330.0	12.4	5.25	5.25	1.1	8.0	12.0	Q2
TPS25831QWRHBTQ1	VQFN	RHB	32	250	180.0	12.4	5.25	5.25	1.1	8.0	12.0	Q2

TAPE AND REEL BOX DIMENSIONS

*All dimensions are nominal

Device	Package Type	Package Drawing	Pins	SPQ	Length (mm)	Width (mm)	Height (mm)
TPS25830QCWRHBRQ1	VQFN	RHB	32	5000	367.0	367.0	35.0
TPS25830QWRHBRQ1	VQFN	RHB	32	3000	367.0	367.0	38.0
TPS25830QWRHBTQ1	VQFN	RHB	32	250	213.0	191.0	35.0
TPS25831QCWRHBRQ1	VQFN	RHB	32	5000	367.0	367.0	35.0
TPS25831QWRHBRQ1	VQFN	RHB	32	3000	367.0	367.0	38.0
TPS25831QWRHBTQ1	VQFN	RHB	32	250	213.0	191.0	35.0

GENERIC PACKAGE VIEW

RHB 32

VQFN - 1 mm max height

5 x 5, 0.5 mm pitch

PLASTIC QUAD FLATPACK - NO LEAD

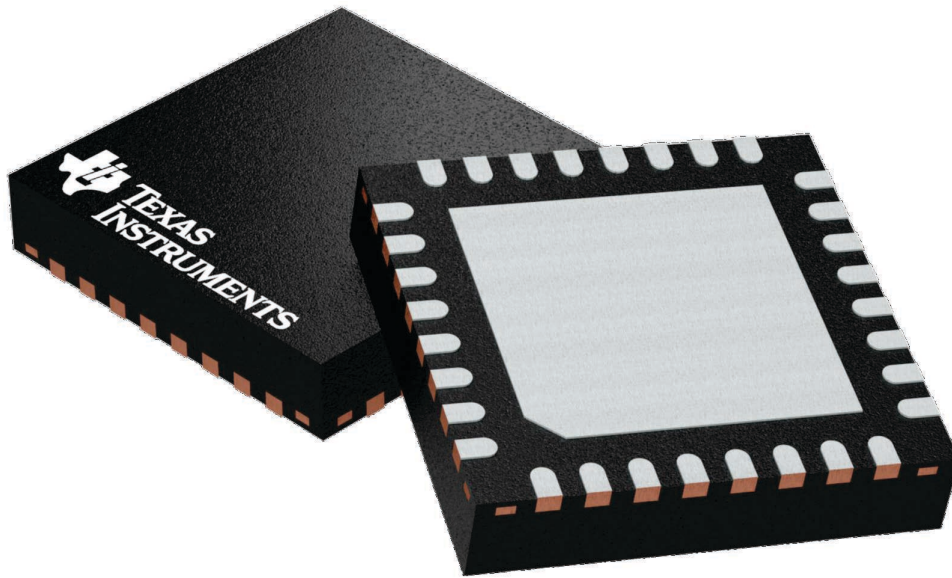

Images above are just a representation of the package family, actual package may vary.
Refer to the product data sheet for package details.

4224745/A

RHB0032R

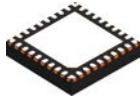

PACKAGE OUTLINE

VQFN - 1 mm max height

PLASTIC QUAD FLATPACK - NO LEAD

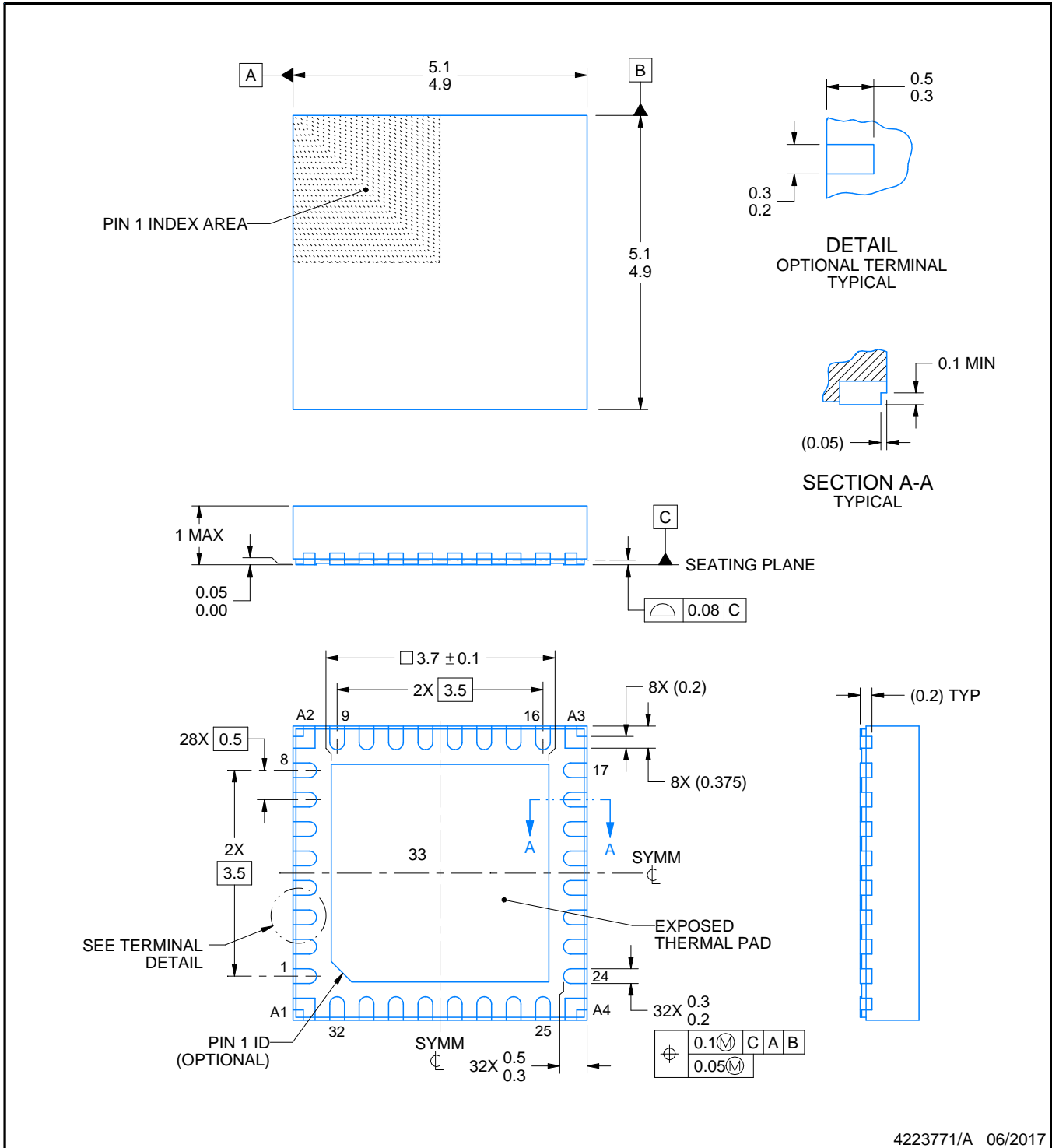

4223771/A 06/2017

NOTES:

1. All linear dimensions are in millimeters. Any dimensions in parenthesis are for reference only. Dimensioning and tolerancing per ASME Y14.5M.
2. This drawing is subject to change without notice.
3. The package thermal pad must be soldered to the printed circuit board for thermal and mechanical performance.

EXAMPLE BOARD LAYOUT

RHB0032R

VQFN - 1 mm max height

PLASTIC QUAD FLATPACK - NO LEAD

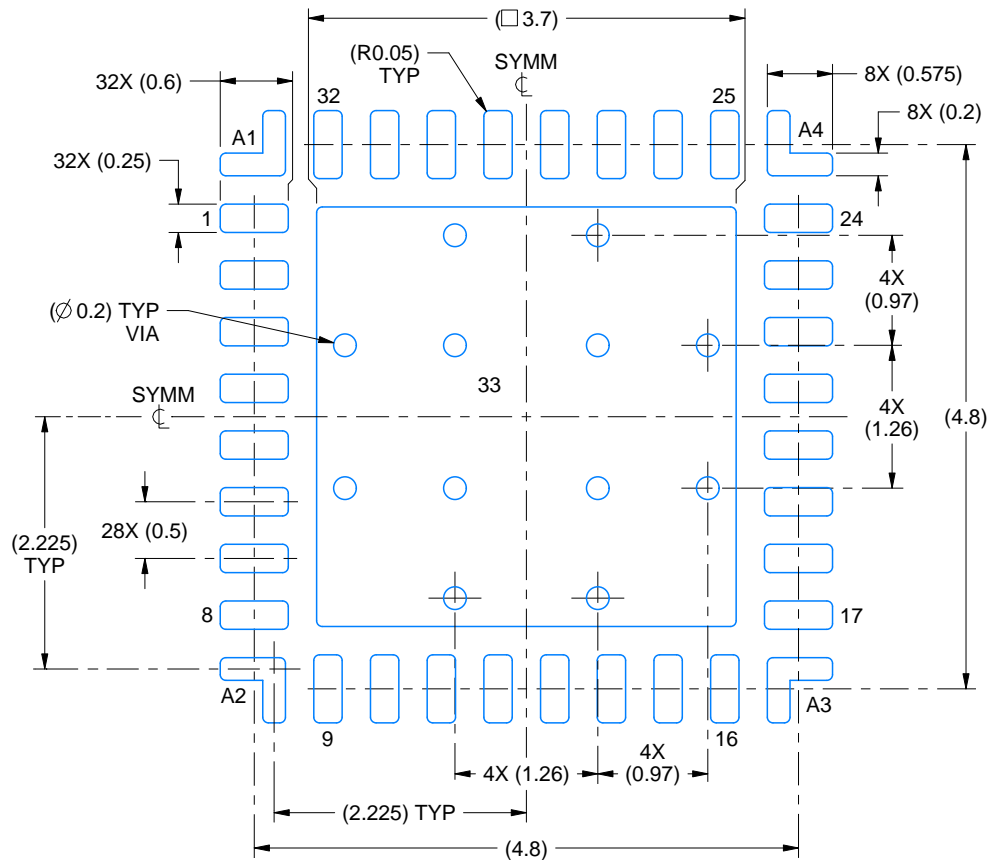

LAND PATTERN EXAMPLE
EXPOSED METAL SHOWN
SCALE:15X

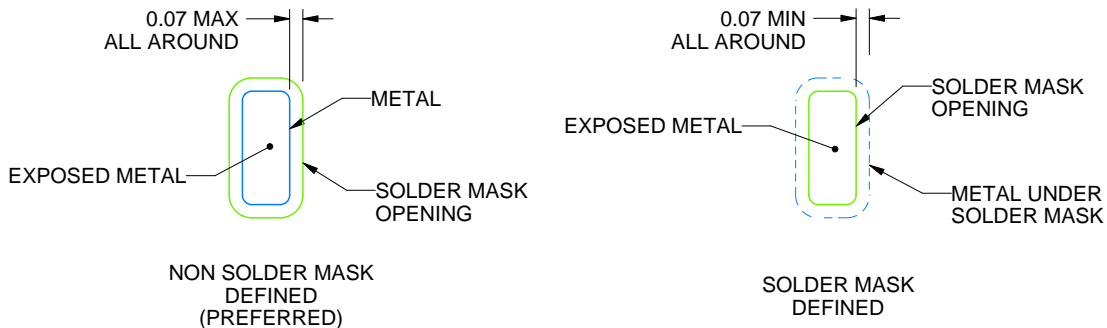

SOLDER MASK DETAILS

4223771/A 06/2017

NOTES: (continued)

4. This package is designed to be soldered to a thermal pad on the board. For more information, see Texas Instruments literature number SLUA271 (www.ti.com/lit/slua271).
5. Vias are optional depending on application, refer to device data sheet. If any vias are implemented, refer to their locations shown on this view. It is recommended that vias under paste be filled, plugged or tented.

EXAMPLE STENCIL DESIGN

RHB0032R

VQFN - 1 mm max height

PLASTIC QUAD FLATPACK - NO LEAD

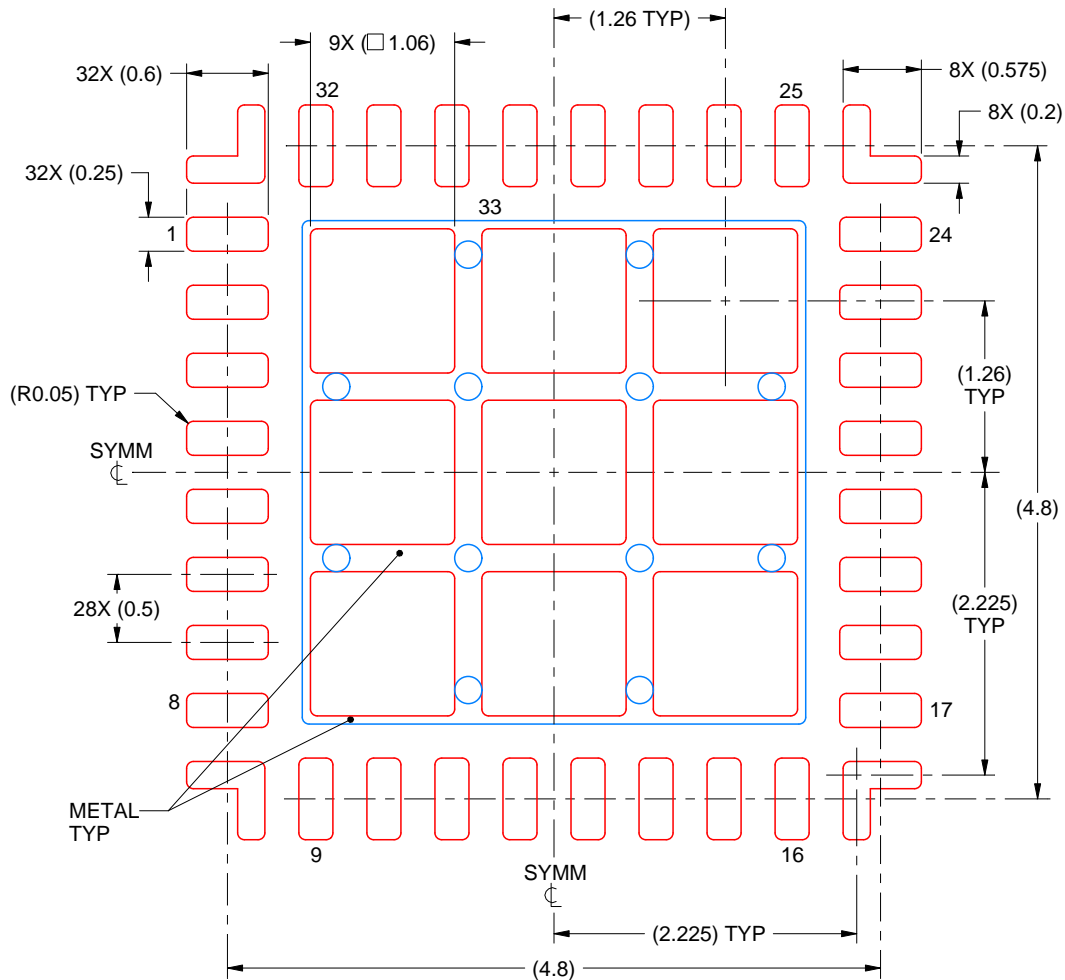

SOLDER PASTE EXAMPLE
BASED ON 0.125 mm THICK STENCIL

EXPOSED PAD 33
74% PRINTED SOLDER COVERAGE BY AREA UNDER PACKAGE
SCALE:18X

4223771/A 06/2017

NOTES: (continued)

6. Laser cutting apertures with trapezoidal walls and rounded corners may offer better paste release. IPC-7525 may have alternate design recommendations.

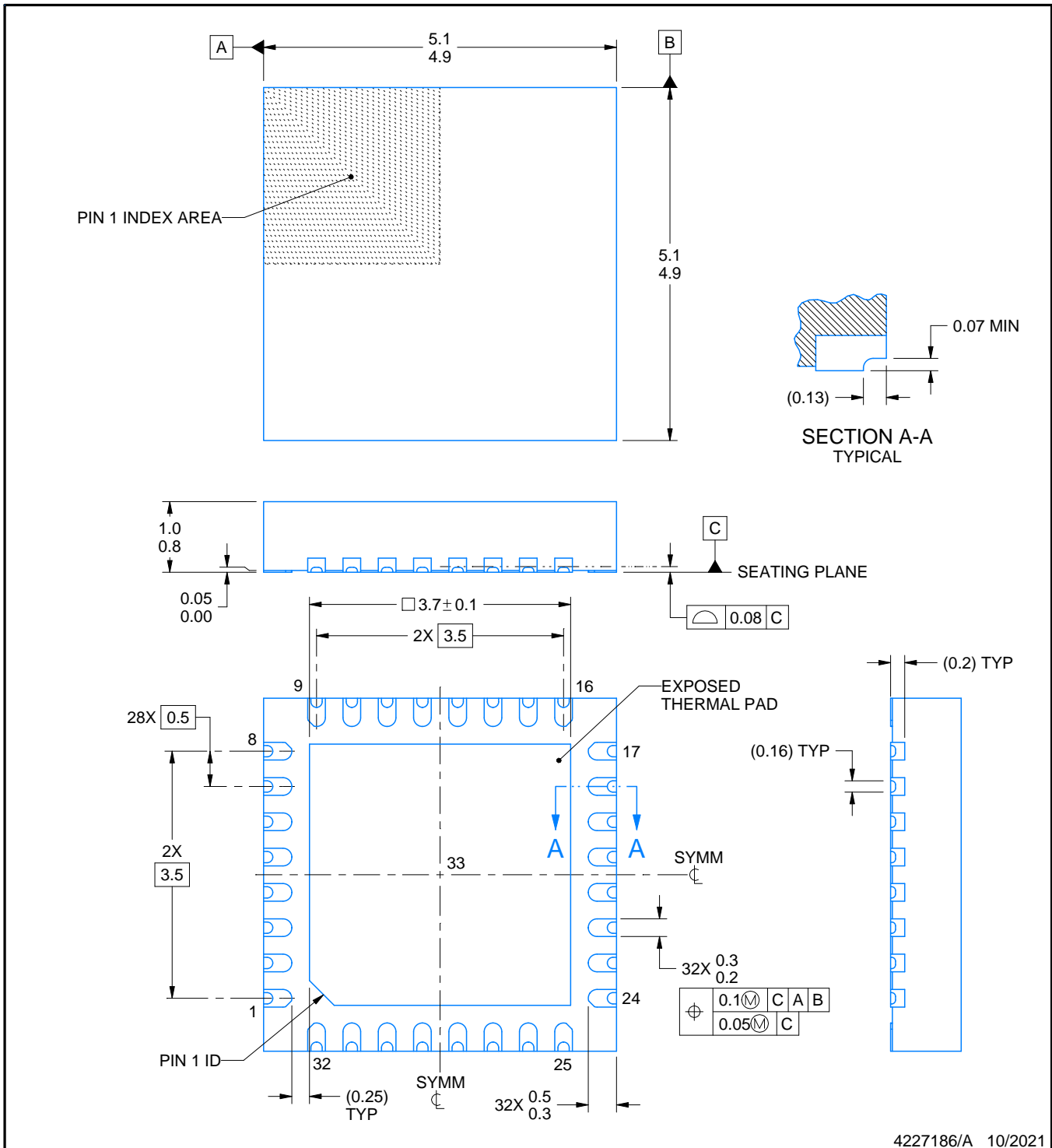
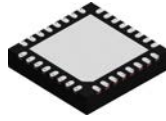

4227186/A 10/2021

NOTES:

1. All linear dimensions are in millimeters. Any dimensions in parenthesis are for reference only. Dimensioning and tolerancing per ASME Y14.5M.
2. This drawing is subject to change without notice.
3. The package thermal pad must be soldered to the printed circuit board for thermal and mechanical performance.

EXAMPLE BOARD LAYOUT

RHB0032AA

VQFN - 1 mm max height

PLASTIC QUAD FLATPACK - NO LEAD

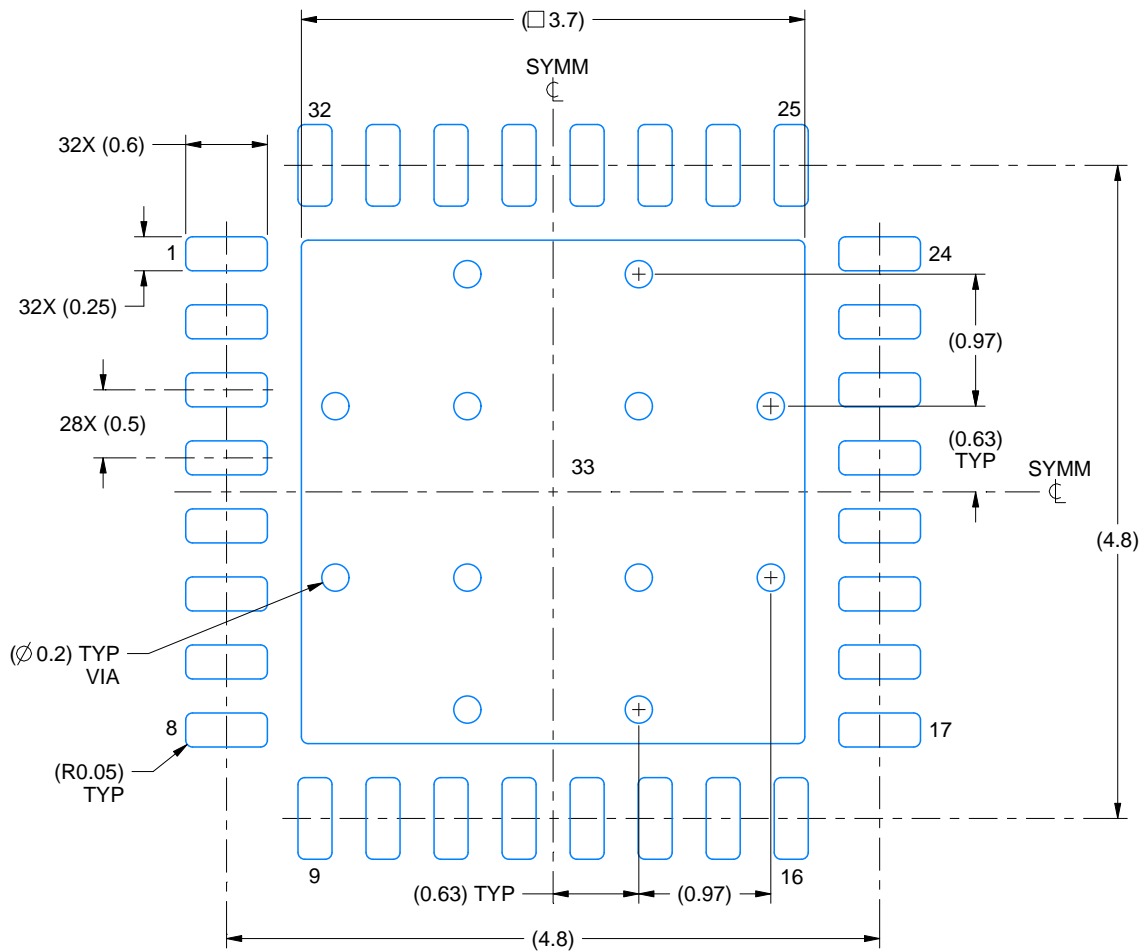

LAND PATTERN EXAMPLE
EXPOSED METAL SHOWN
SCALE:18X

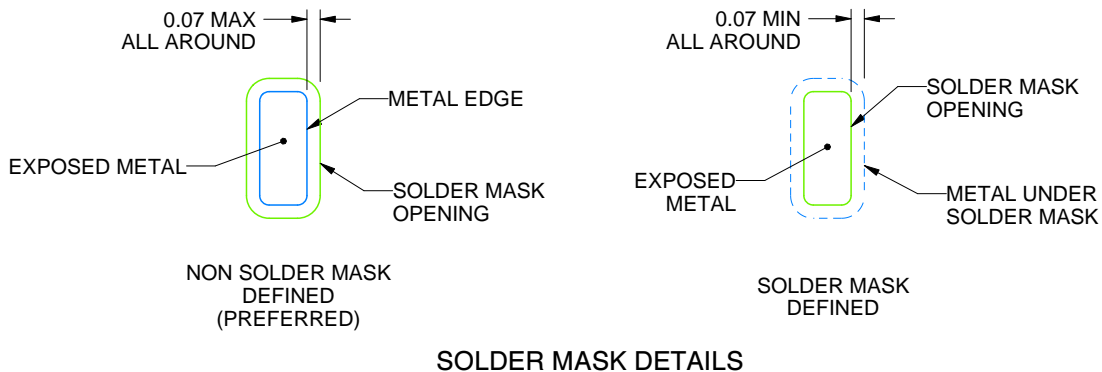

SOLDER MASK DETAILS

4227186/A 10/2021

NOTES: (continued)

- This package is designed to be soldered to a thermal pad on the board. For more information, see Texas Instruments literature number SLUA271 (www.ti.com/lit/slua271).
- Vias are optional depending on application, refer to device data sheet. If any vias are implemented, refer to their locations shown on this view. It is recommended that vias under paste be filled, plugged or tented.

EXAMPLE STENCIL DESIGN

RHB0032AA

VQFN - 1 mm max height

PLASTIC QUAD FLATPACK - NO LEAD

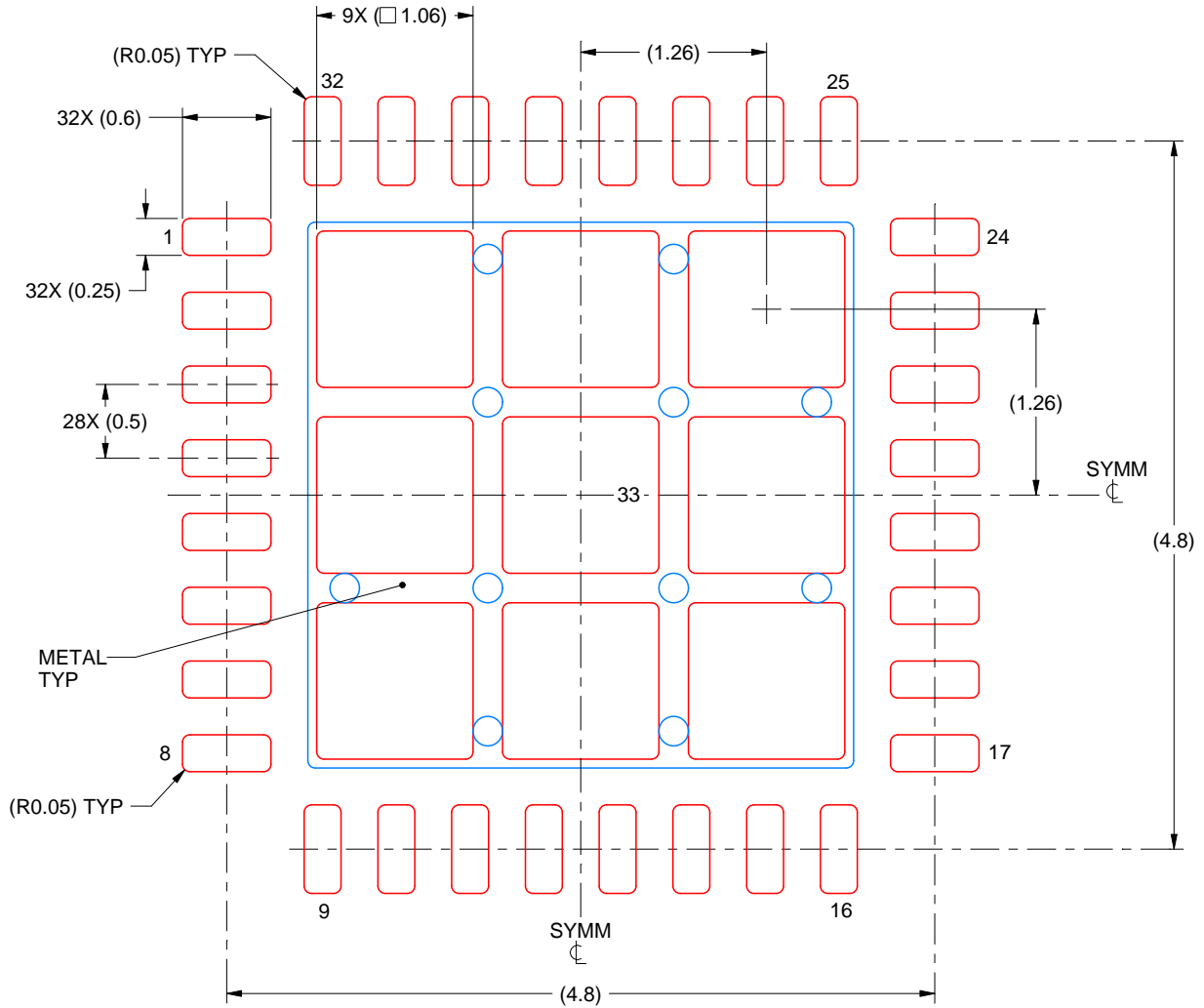

SOLDER PASTE EXAMPLE
 BASED ON 0.125 mm THICK STENCIL

EXPOSED PAD 33:
 74% PRINTED SOLDER COVERAGE BY AREA UNDER PACKAGE
 SCALE:20X

4227186/A 10/2021

NOTES: (continued)

6. Laser cutting apertures with trapezoidal walls and rounded corners may offer better paste release. IPC-7525 may have alternate design recommendations.

IMPORTANT NOTICE AND DISCLAIMER

TI PROVIDES TECHNICAL AND RELIABILITY DATA (INCLUDING DATA SHEETS), DESIGN RESOURCES (INCLUDING REFERENCE DESIGNS), APPLICATION OR OTHER DESIGN ADVICE, WEB TOOLS, SAFETY INFORMATION, AND OTHER RESOURCES "AS IS" AND WITH ALL FAULTS, AND DISCLAIMS ALL WARRANTIES, EXPRESS AND IMPLIED, INCLUDING WITHOUT LIMITATION ANY IMPLIED WARRANTIES OF MERCHANTABILITY, FITNESS FOR A PARTICULAR PURPOSE OR NON-INFRINGEMENT OF THIRD PARTY INTELLECTUAL PROPERTY RIGHTS.

These resources are intended for skilled developers designing with TI products. You are solely responsible for (1) selecting the appropriate TI products for your application, (2) designing, validating and testing your application, and (3) ensuring your application meets applicable standards, and any other safety, security, regulatory or other requirements.

These resources are subject to change without notice. TI grants you permission to use these resources only for development of an application that uses the TI products described in the resource. Other reproduction and display of these resources is prohibited. No license is granted to any other TI intellectual property right or to any third party intellectual property right. TI disclaims responsibility for, and you will fully indemnify TI and its representatives against, any claims, damages, costs, losses, and liabilities arising out of your use of these resources.

TI's products are provided subject to [TI's Terms of Sale](#) or other applicable terms available either on ti.com or provided in conjunction with such TI products. TI's provision of these resources does not expand or otherwise alter TI's applicable warranties or warranty disclaimers for TI products.

TI objects to and rejects any additional or different terms you may have proposed.

Mailing Address: Texas Instruments, Post Office Box 655303, Dallas, Texas 75265
Copyright © 2022, Texas Instruments Incorporated

Looking for pricing, stock, or lifecycle information?

Click below to explore more details on WIN SOURCE:

- ⊖ [View MSMCJLCE33A on WIN SOURCE](#)
- ⊖ [Microchip Technology Information](#)

Optimize Your Supply Chain with WIN SOURCE Solutions

- ✓ Global Sourcing Solution
- ✓ Obsolete Management
- ✓ Cost Control Management
- ✓ Shortage Management
- ✓ Alternative Solution
- ✓ Excess Inventory Management