



**THE DATASHEET OF
DS28EA00EVKIT#**





DS28EA00 Evaluation Kit

Evaluates: DS28EA00

General Description

The DS28EA00 evaluation system (EV system) consists of a single evaluation kit (EV kit) that includes an evaluation board (EV board) made up of three subsections that can be broken/snapped off into three independently exercisable boards. See Figure 1 for a picture of the stand-alone EV board and Figure 2 for a picture of the EV board snapped and cabled together. Three DS28EA00 temperature chips with GPIO and sequence detect can be found on the EV board, one per subsection. Also included in the kit are connectivity items, such as serial cables, a 1-Wire® USB adapter, and jumpers. Free evaluation software, the OneWireViewer, is available for download from the web page listed in the *Support Resources* section.

Since one of the major features of the DS28EA00 is detection of physical sequence, a block of dipswitches are provided on each subsection of the EV board to re-order the physical connection between the chips. Optionally, the customer can break off the subsections of the eval board, connect them together with the provided cables, and re-order the physical sequence of the DS28EA00s that way. The OneWireViewer evaluation software can then be used to exercise the functionality of the chips and provide a way for an evaluator to see the actual physical connection sequence of the chips. The algorithm to detect the connection order is called chain mode. More information on chain mode can be found in Application Note 4037.

Support Resources

- 1) DS28EA00 EV Kit Data Sheet:
www.maxim-ic.com/DS28EA00EVKIT
- 2) 1-Wire Drivers:
www.maxim-ic.com/1-Wiredrivers
- 3) DS28EA00 EV Kit Software (OneWireViewer):
www.maxim-ic.com/onewireviewer
- 4) OneWireViewer User's Guide:
www.maxim-ic.com/AN3358
- 5) Application Note 4037:
www.maxim-ic.com/AN4037
- 6) Web-Based Discussion Forum:
<http://discuss.maxim-ic.com>
- 7) Technical Support:
<http://support.maxim-ic.com/1-Wire>

1-Wire is a registered trademark of Maxim Integrated Products, Inc.



Maxim Integrated Products 1

For pricing, delivery, and ordering information, please contact Maxim Direct at 1-888-629-4642, or visit Maxim's website at www.maxim-ic.com.

Features

- ◆ **Easy Setup**
- ◆ **Stand-Alone EV Board**
 - Contains Three Separate, Breakable Subsections with a DS28EA00 Per Subsection**
 - Dipswitch Block on Each EV Board Subsection Routes Physical Chain-Mode Connections Between Chips When Used as a Stand-Alone Board**
 - EV Board's Subsections are Breakable Into Three Separate Boards, Each of Which Evaluates a Single DS28EA00 or, When Cabled Together, Evaluate Chain-Mode Searching**
 - LEDs Give Visual Indicators of PIO Activity**
 - 6-Pin Terminal Strip Allows PIO Testing Outside of Chain Mode**
- ◆ **PC Connectivity Included**
- ◆ **RoHS Compliant**
- ◆ **Free Downloadable Evaluation Software Available**

Ordering Information

PART	TYPE
DS28EA00EVKIT	EV Kit

EV Kit Contents

DESIGNATION	QTY	DESCRIPTION
H1	6	2-pin shunts (for jumpering) Tyco/Amp 881545-2
H2	1	Instruction sheet
H3	3	7' RJ11 male to RJ11 male serial cable, 6-pin, 6-connection Interconnect/Digikey H2663R-07-ND
H4	1	1-Wire USB adapter without ID Dallas Semiconductor DS9490R-S
H5	1	Antistatic bag to hold items H1-H4
H6	1	DS28EA00 EV board (see <i>EV Board Component List</i>)
H7	1	Cardboard box to hold EV kit contents (H1-H6)

DS28EA00 Evaluation Kit

EV Board Component List

DESIGNATION	QTY	DESCRIPTION
RJ1–RJ6	6	RJ11 6-pin, 6-connection, right angle AMP 520250-3
R1–R6	6	SMT 1206 1kΩ resistor Panasonic-ECG ERJ-8ENF1001V
R7–R12	6	SMT 1206 10kΩ resistor Panasonic-ECG ERJ-8ENF1002V
D1–D3	3	SMT 1206 green, surface-mount LED LiteOn LTST-C150GKT
D4–D6	3	SMT 1206 yellow, surface-mount LED LiteOn LTST-C150YKT
Q1–Q7	7	SMT SOT23 BSS84 transistor P-type FET OnSemiconductor BSS84LT1G

DESIGNATION	QTY	DESCRIPTION
C1–C3	3	SMT 1206 1500pF capacitor KMET C1206C152K5RACTU
J1–J3	3	100-mil, centers square-post terminal strip (6-pin jumper posts) MOLEX 22-28-4062
U1	3	DS28EA00 1-Wire digital thermometer with sequence detect and PIO (8-pin μSOP) Maxim DS28EA00
JB1–JB3	3	Jumper block dipswitch with 7 built-in switches (14 DIP) Grayhill Incorporated 76SB07ST

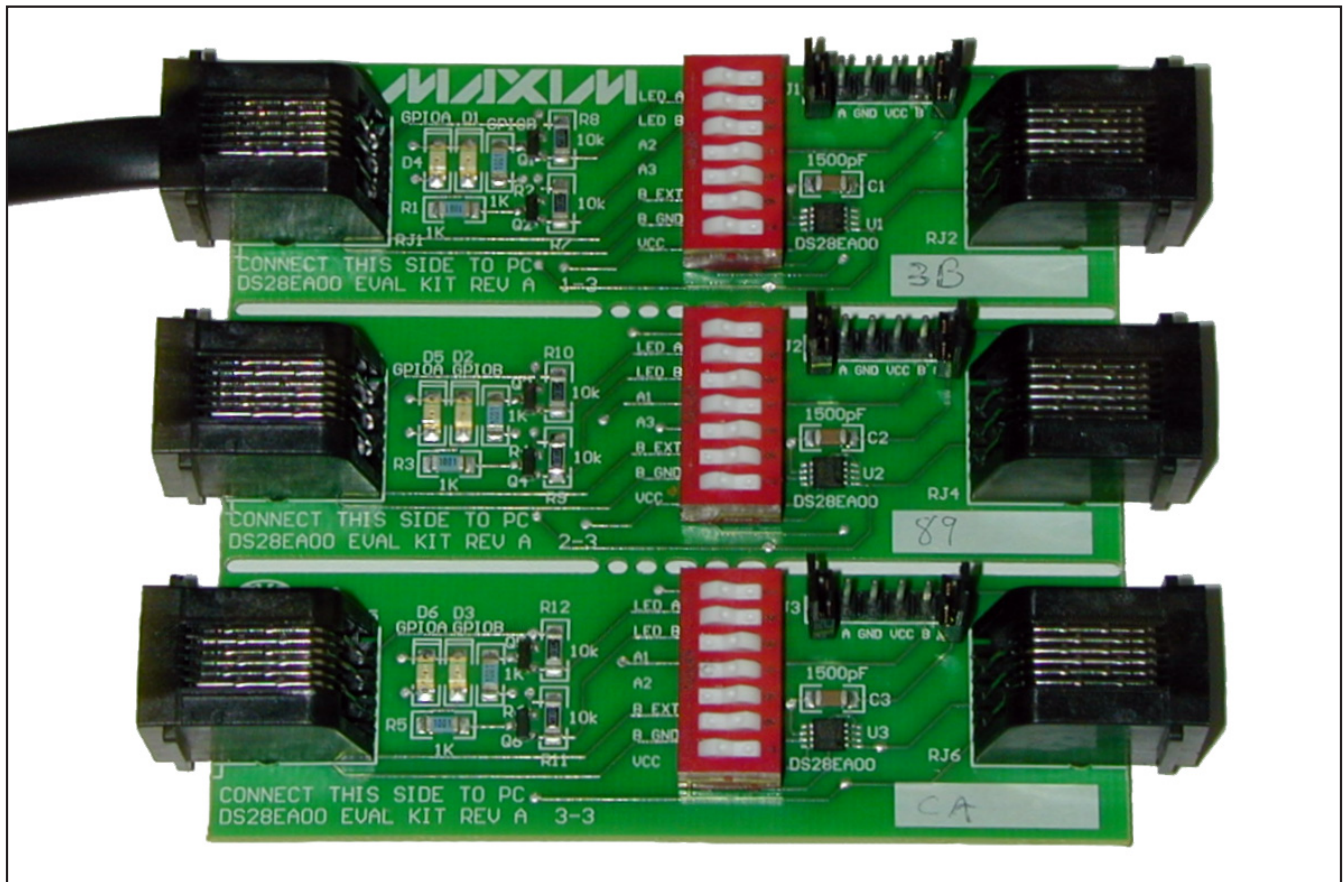

Figure 1. Stand-Alone EV Board

DS28EA00 Evaluation Kit

Evaluates: **DS28EA00**

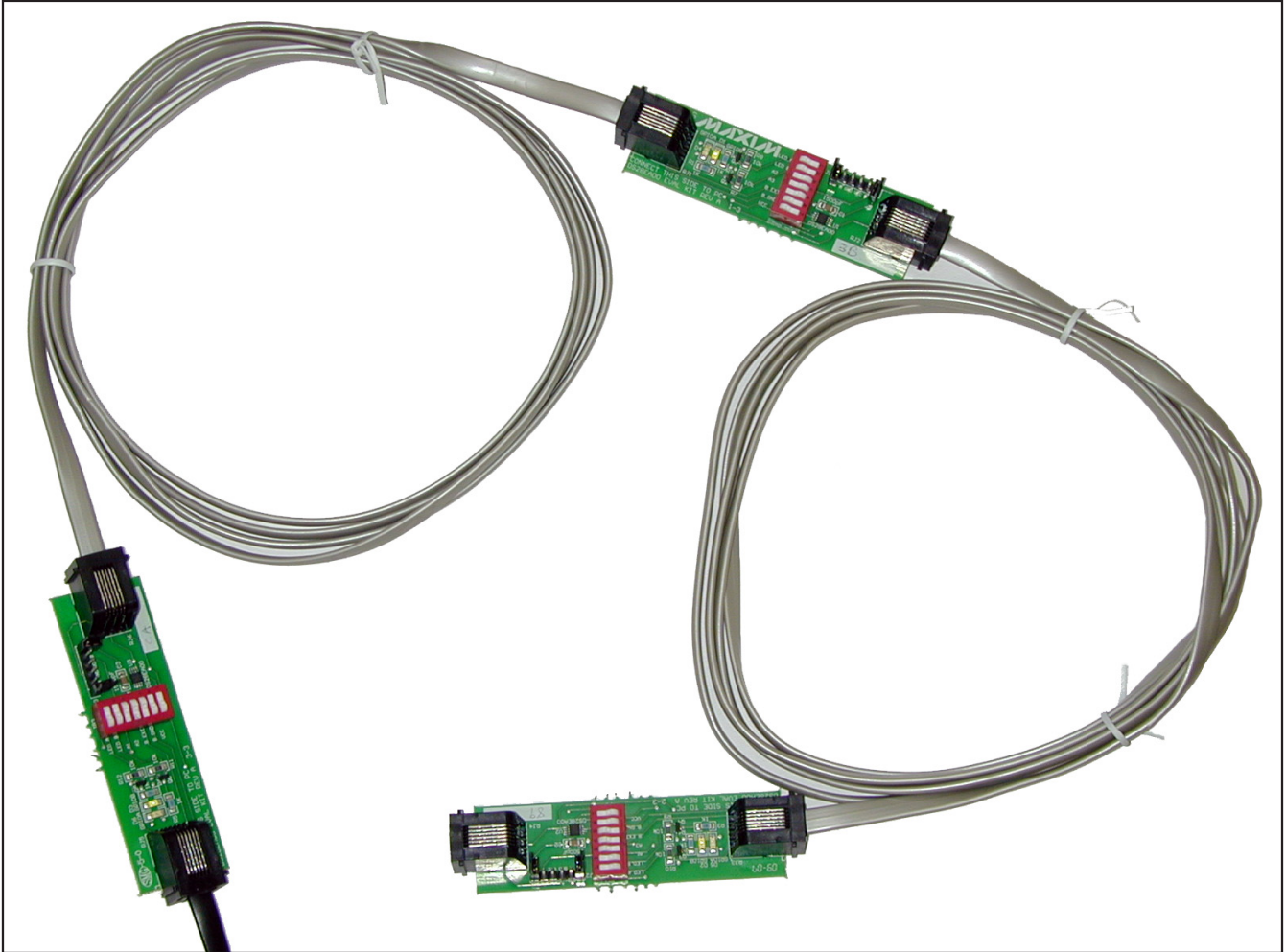

Figure 2. EV Board Snapped and Cabled

Quick Start

Note: In the following sections, software-related items are identified by bolding. Text in bold refers to items directly from the EV kit software. Text in bold and underlined refers to items from the Windows® operating system.

- 1) Make sure all kit components are present and accounted for (see *EV Board Component List*).
- 2) The software mentioned in this document requires a PC with a spare USB port running a Windows 98SE, 2000, or XP operating system. It is required to have system administrator privileges for installing the drivers, as well as an active internet connection.
- 3) Download and install the 1-Wire Drivers package (see *Support Resources* for links to the download). The install process is straightforward. Respond correctly to the prompts (including when to plug-in the DS9490R-S 1-Wire adapter).
- 4) If trouble occurs during the 1-Wire drivers installation, refer to Application Note 1740: *White Paper 6: 1-Wire Drivers Installation Guide for Windows*. Specifically look at *Appendix A: 1-Wire USB Adapter (DS9490) Installation Help*.
- 5) Install Java™ version 1.4 or above on the PC if not already done (www.java.com).

Windows is a registered trademark of Microsoft Corp.

Java is a trademark of Sun Microsystems.

DS28EA00 Evaluation Kit

- 6) Install the OneWireViewer evaluation software. Click the **Launch the OneWireViewer** button found on the page.
- 7) Prepare the stand-alone EV board to be connected to the computer for the first time.
 - a) Open (set to nonconducting) all the switches in the three dipswitch blocks. The open side of the dipswitch blocks is the left-hand side.
 - b) Close (set to conducting) the switches 1, 2, and 7 on each dipswitch block. They are labeled LED A, LED B, and VCC, respectively, and give power to the PIO LEDs and to the DS28EA00 chips.
 - c) Physically connect the DS28EA00s PIOs together so that their order is top board subsection first, middle subsection second, and the bottom subsection last, giving a physical sequence of 1, 2, 3, from top to bottom:
 - i) Set the top board's DS28EA00 to be the beginning of the chain in chain mode by grounding its PIO B (closing switch 7 which is labeled B GND).
 - ii) Route the connections through switches 3 and 4 on each dipswitch block (see Figure 9). The switch pair represents the two possible subsections that could be previously connected to the current subsection. At most only one switch should be closed for any subsection. Each switch is labeled as A1, A2, or A3. Here, A1 indicates the top subsection (and its DS28EA00), A2 the middle, and A3 the bottom. The switch pair of the first subsection in the chain should be kept open (nonconducting). See Table 2 for all possible connection sequences. Select the sequence A1, A2, A3 (top to bottom).
- 8) Connect the hardware to the computer.
 - a) The DS9490R-S 1-Wire adapter should already be connected to a spare USB port on the computer.
 - b) Connect the EV board to the DS9490R-S with one of the RJ11 serial cables. Plug in the stand-alone board to the PC through one of the RJ11 sockets located on the left-hand side of the EV board (it does not matter which one).
- 9) Run the OneWireViewer by either clicking the button on the OneWireViewer web page or by running Java WebStart's application launcher. This can nor-

mally be found in the following default install directory of the Java Runtime Environment's bin directory: C:\Program Files\Java\jre1.6.0_01\bin. Open a command-line from this directory and type in "javaws-viewer". A GUI window appears and you can right-click on the OneWireViewer icon to either launch it online (if the PC is connected to the internet) or launch it offline (if the PC is disconnected). You can also save a OneWireViewer shortcut to the desktop if so desired.

Detailed Description of Software

See the OneWireViewer's main window in Figure 3. Note that it is made up of three sections:

- 1) **Device List.** The device list shows the 1-Wire network addresses of all 1-Wire parts connected on the specified 1-Wire network, along with the part number. For this EV board, it lists all three DS28EA00s. Figure 3 shows three DS28EA00s on the network.
- 2) **Search Mode.** Three search modes, along with **Pause All Searching**, are listed in the lower left-hand corner of Figure 3. The **Show Normal Devices** mode is actually a binary tree search, so the device order in the device list does not indicate physical connection sequence. **Show Alarming Devices** is a search mode that finds alarming devices, such as a DS28EA00 whose temperature is above the high-temperature alarm trip point or below the low-temperature alarm trip point. Finally, **Show Chain Mode Devices** is a search mode that orders the device list of the OneWireViewer in order of physical connection sequence. If a nonchain-mode device is connected to the network, it does not participate in the search and does not show up in the device list. See an example of chain-mode searching in Figure 4.
- 3) **Function Tabs.** Several tabs exist in the main window of the OneWireViewer. Each tab represents a related function set that is exercisable for the specific device chosen in the device list. The DS28EA00 contains **Description**, **Temperature**, **Switch**, and **Memory** tabs as the part has that functionality. Clicking on a specific tab switches to a GUI panel that can exercise the functionality indicated by the tab of the selected DS28EA00. These function tabs (along with the search modes) represent the core of the DS28EA00. See the *Function Tabs* section for more detail.

DS28EA00 Evaluation Kit

Evaluates: DS28EA00

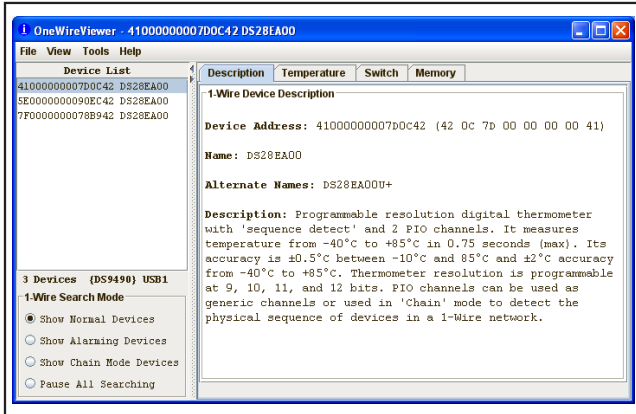

Figure 3. OneWireViewer Main Window

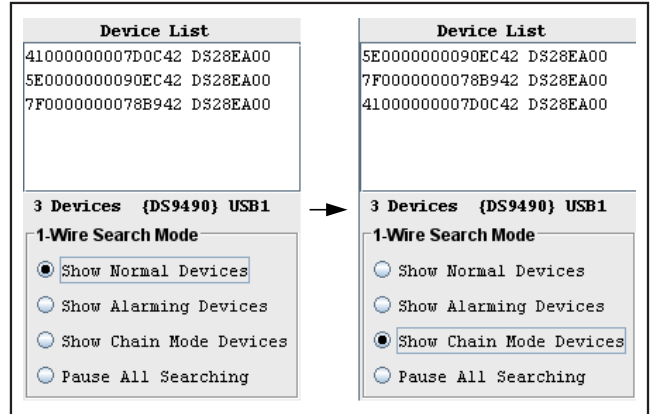

Figure 4. Normal- vs. Chain-Mode Searching in the OneWireViewer

Switching Between Chain Mode and Normal Search Modes

See Figure 4 for two screenshots of the OneWireViewer's device list. Keep in mind that chain-mode searching arranges the device list of the OneWireViewer in order of physical connection sequence, and normal-mode searching arranges the device list in the order of the 1-Wire search algorithm. The first screenshot shows normal-mode searching and the second shows chain-mode searching. Notice how the device list rearranges when selecting the different 1-Wire search modes.

Function Tabs

The OneWireViewer function tabs, as mentioned earlier, allow a user to exercise a related set of functions of the selected DS28EA00. The DS28EA00 shows four tabs on the OneWireViewer: the **Description**, **Temperature**, **Switch**, and **Memory** tabs.

The **Description** tab is shown in Figure 3. It is present for any selected 1-Wire device and just gives a textual overview of the part's features and specs. The **Temperature**, **Switch**, and **Memory** tabs are described in the following sections and shown visually in Figures 5, 6, and 7, respectively. For detailed documentation on the DS28EA00's temperature, memory, and PIO (switch) operation, refer to the DS28EA00 data sheet: www.maxim-ic.com/DS28EA00.

Function Tabs: Temperature

As seen in Figure 5, the OneWireViewer's **Temperature** function tab is made up of three sections: **Info**, **Graph**, and **Thermometer**. The info section displays the most recently sampled temperature, gives the user a choice

to display the temperature in degrees Fahrenheit or Celsius, and allows for setting the temperature conversion resolution of the selected DS28EA00. The **Graph** section graphs temperature vs. time. Right-clicking the **Graph** gives the ability to export temperatures to the computer's clipboard where they can be pasted into another application, and gives the ability to resize the graph. Finally, the **Thermometer** section shows the latest sampled temperature in a thermometer-style graph.

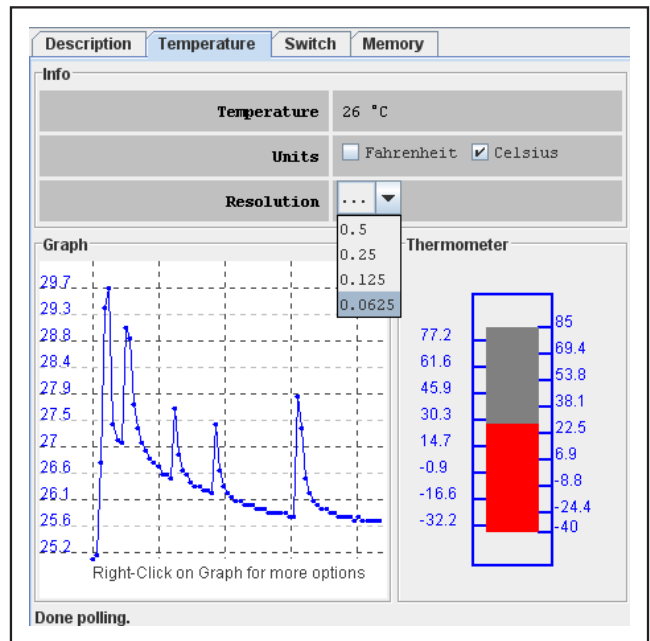

Figure 5. OneWireViewer Function Tabs: Temperature

DS28EA00 Evaluation Kit

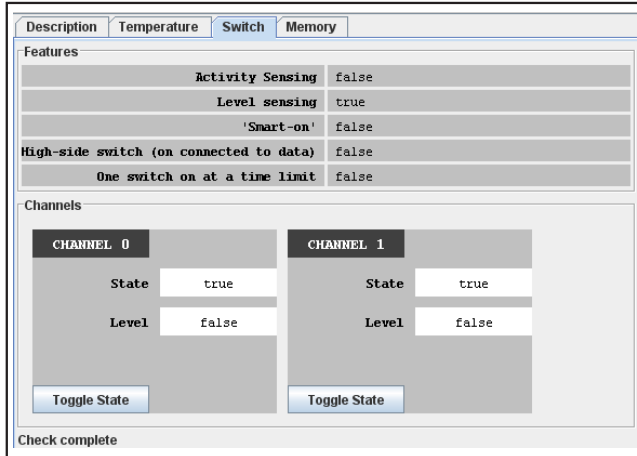

Figure 6. OneWireViewer Function Tabs: Switch

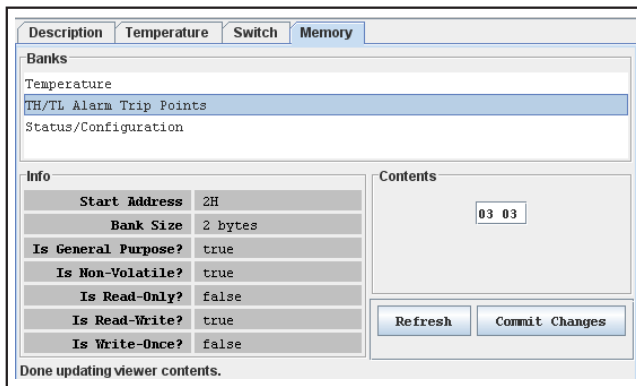

Figure 7. OneWireViewer Function Tabs: Memory

Function Tabs: Switch

Figure 6 shows the OneWireViewer's **Switch** function tab. It is made up of two sections: **Features** and **Channels**. The **Features** section gives general **Switch** information such as type and abilities, and the **Channels** section allows the user to toggle the switches of the DS28EA00 and to read their input states.

Function Tabs: Memory

The OneWireViewer's **Memory** function tab consists of three sections: **Banks**, **Info**, and **Contents**. The **Banks** section displays the three DS28EA00 memory banks available. The **Info** section shows the features, type, size, and starting address of the memory bank selected. Finally, the **Contents** section allows the user to refresh (read), or commit changes to (update) the selected memory bank's contents (in hexadecimal format only).

Notice in the TH/TL alarm trip points memory bank, two bytes represent temp-high and temp-low alarms, respectively. To update the alarm trip points, first convert the alarm in degrees Celsius to hexadecimal value and click the **Commit Changes** button. Keep in mind that the alarm trip points are not used until a temperature actually is taken by the chip.

Detailed Description of Hardware

Figure 8 gives a visual overview of the hardware sections of the DS28EA00EVKIT's EV board. The first component listed in Figure 8 is the RJ11 IN from the PC. Any of the three RJ11s listed on the left-hand side of the EV board can be considered the RJ11 IN (1-Wire data) from the PC (if the EV board is configured to be stand-alone, i.e., not broken into separate boards).

The PIO-A and B LEDs are indicators of PIO activity. They can be optionally turned off for testing the parts in parasite-powered mode. The dipswitch blocks shown in Figure 8 give the user the ability to power and ground certain component pins and to route the PIO chain-mode connections between the DS28EA00s. The PIOs can also be independently exercised outside of chain mode through the pin-input jumpers (jumper to VCC or GND for each I/O pin).

DS28EA00 Evaluation Kit

Evaluates: DS28EA00

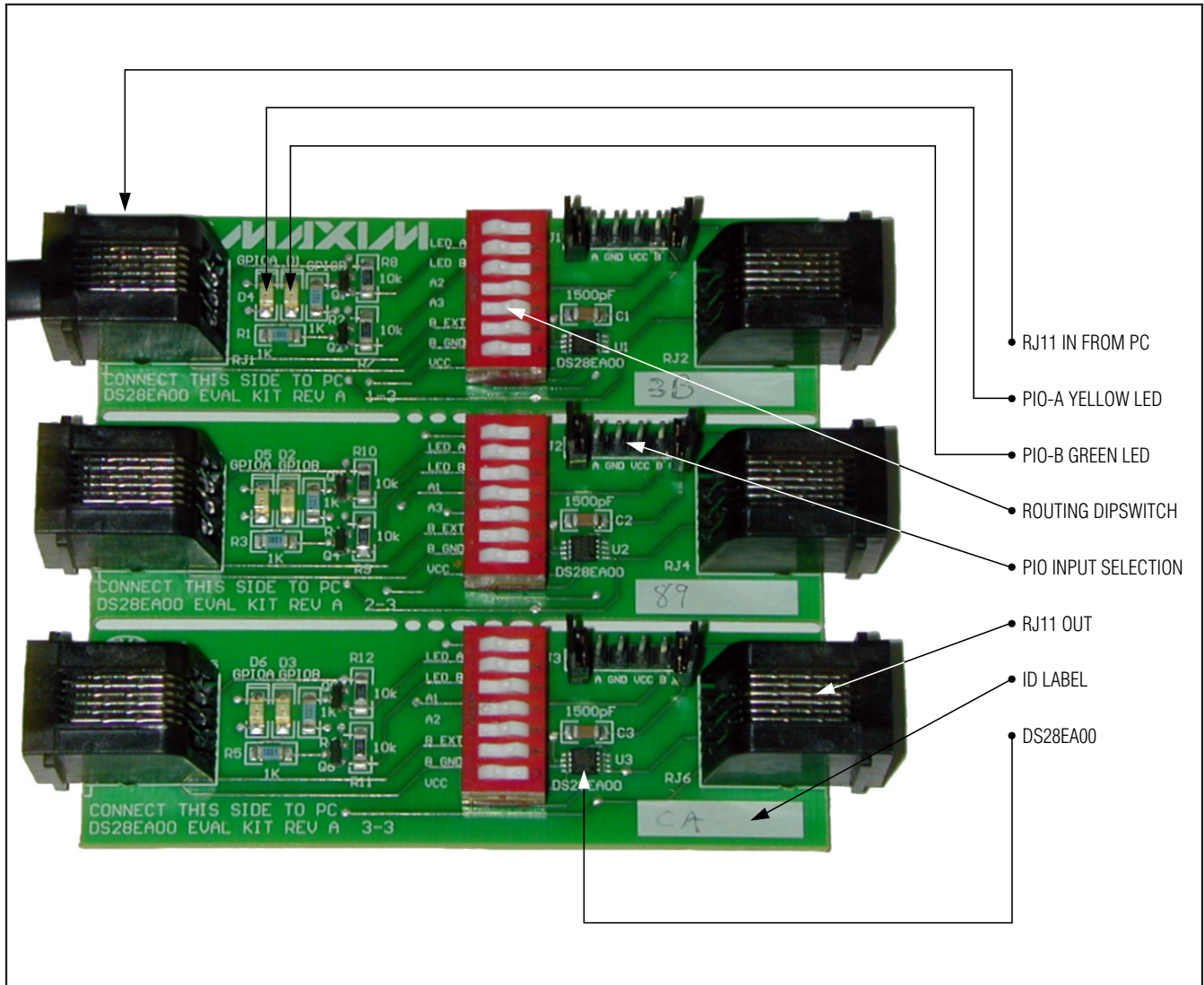

Figure 8. EV Board Component Map

Also on the EV board are RJ11 OUT sockets. They are to be used whenever the stand-alone EV board is broken into separate boards and cabled together. The RJ11 OUT socket should be cabled to the next board's RJ11 IN socket.

Finally, three blank white ID labels are located on the EV board, one in the lower right-hand corner of each board subsection. They are to be used as writing areas on which to write the CRC of the DS28EA00s' 1-Wire network addresses (for keeping track of which DS28EA00 belongs to which board subsection).

DS28EA00 Evaluation Kit

The dipswitch block in Figure 9 routes chain-mode PIO connections between DS28EA00s. It also provides switches for powering the DS28EA00s and their PIO LEDs, enabling the RJ11 OUT sockets for cabling the snapped-apart boards together, and grounding PIO-B pins for chain-mode operation.

Figure 9 shows one of the dipswitch blocks and its silkscreen labels. The dipswitch block has many functions. See Table 1 for a listing of each switch with a brief description of what each switch does. Switches 1 and 2 provide for optionally powering PIO LEDs (it's suggested that users power LEDs for visual indication of PIO activity), and for optionally giving power to the DS28EA00's VCC, switch 7. But, its primary purpose is to route PIO chain-mode connections with switches 3, 4, 5, and 6. Switches 3 and 4, labeled A2 and A3 are used to actually re-route the physical connections between each DS28EA00 I/O pins. Since there are three boards and only two switches, the labels on these two switches could be A1, A2, or A3, with A1 referring to the top board, A2 the middle, and A3 the bottom board. However, after snapping and separating the three boards, these switches cease to function as routing switches so switch 5, labeled B EXT becomes

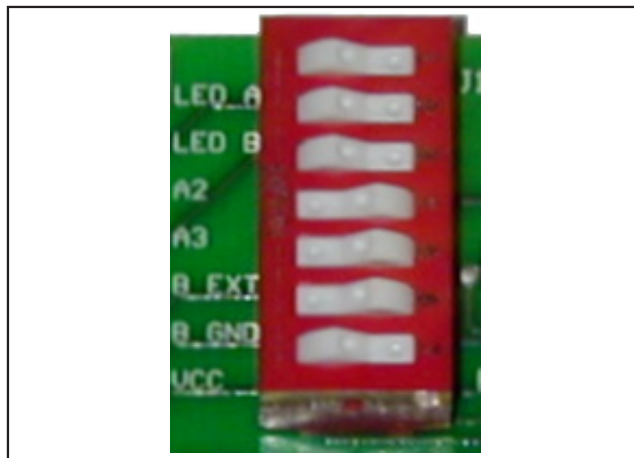

Figure 9. EV Board Dipswitch

important. It enables the EV board's RJ11 OUT sockets, allowing the snapped-apart boards to be cabled together. Finally, switch 6, labeled B GND is used to ground the PIO-B pin of the associated DS28EA00. This effectively marks the DS28EA00 as the first sensor in the chain-mode sequence.

Table 1. Dipswitch Settings

SWITCH	SILKSCREEN LABEL	DESCRIPTION
1	LED A	Powers PIO A LED when closed.
2	LED B	Powers PIO B LED when closed.
3	Ax (x could be 1, 2 or 3)	Chain-mode connection routing switch.
4	Ax (x could be 1, 2 or 3)	Chain-mode connection routing switch.
5	B EXT	When closed, the switch enables RJ11 OUT for cabling together snapped-apart board subsections.
6	B GND	Grounds PIO B when closed.
7	VCC	Powers DS28EA00 when closed.

DS28EA00 Evaluation Kit

Evaluates: DS28EA00

EV Board Chain-Mode Routing

As mentioned earlier there are two ways to route chain-mode connections. The first is done through the dip-switch blocks of the stand-alone, unbroken EV board. See Table 2 for a complete list of possible DS28EA00 sequences and switch positions. Three switches are involved in re-routing the chain-mode sequence. Switch 3 and 4 route the actual PIO connections, and switch 6 optionally grounds PIO-B to indicate the first DS28EA00 in the chain. Every possible chain-mode sequence for the EV board is listed in Table 2. However, there is a method to closing the switches without having to reference the table. The routing switches on each board

subsection represent the other two possible subsections that could be connected. However, it represents the subsection connected previous to the current one in the chain. At most only one switch should be closed for any subsection. For the first subsection in the chain, the two routing switches should remain open.

The second way to route chain-mode connections is to simply break the EV board into its three individual subsections. To route chain-mode connections, then simply requires a re-configuration of the three boards in the desired order. When cabling the three boards, take care that switch 5, B EXT, is closed. Closing switch 5 enables the RJ11 OUT on the board. Do this for each board.

Table 2. Chain-Mode Connection Dipswitch Routing

SEQUENCE	SWITCH	SUBSECTION A1	SUBSECTION A2	SUBSECTION A3
A1 A2 A3	SWITCH 3		CLOSED	
	SWITCH 4			CLOSED
	SWITCH 6	CLOSED		
A1 A3 A2	SWITCH 3			CLOSED
	SWITCH 4		CLOSED	
	SWITCH 6	CLOSED		
A2 A1 A3	SWITCH 3	CLOSED		CLOSED
	SWITCH 4			
	SWITCH 6		CLOSED	
A2 A3 A1	SWITCH 3			
	SWITCH 4	CLOSED		CLOSED
	SWITCH 6		CLOSED	
A3 A1 A2	SWITCH 3		CLOSED	
	SWITCH 4	CLOSED		
	SWITCH 6			CLOSED
A3 A2 A1	SWITCH 3	CLOSED		
	SWITCH 4		CLOSED	
	SWITCH 6			CLOSED

Note: The open or “nonconducting” side of the dipswitches is to the left. Closed or “conducting” is to the right. “Open” is indicated by blank fields.

DS28EA00 Evaluation Kit

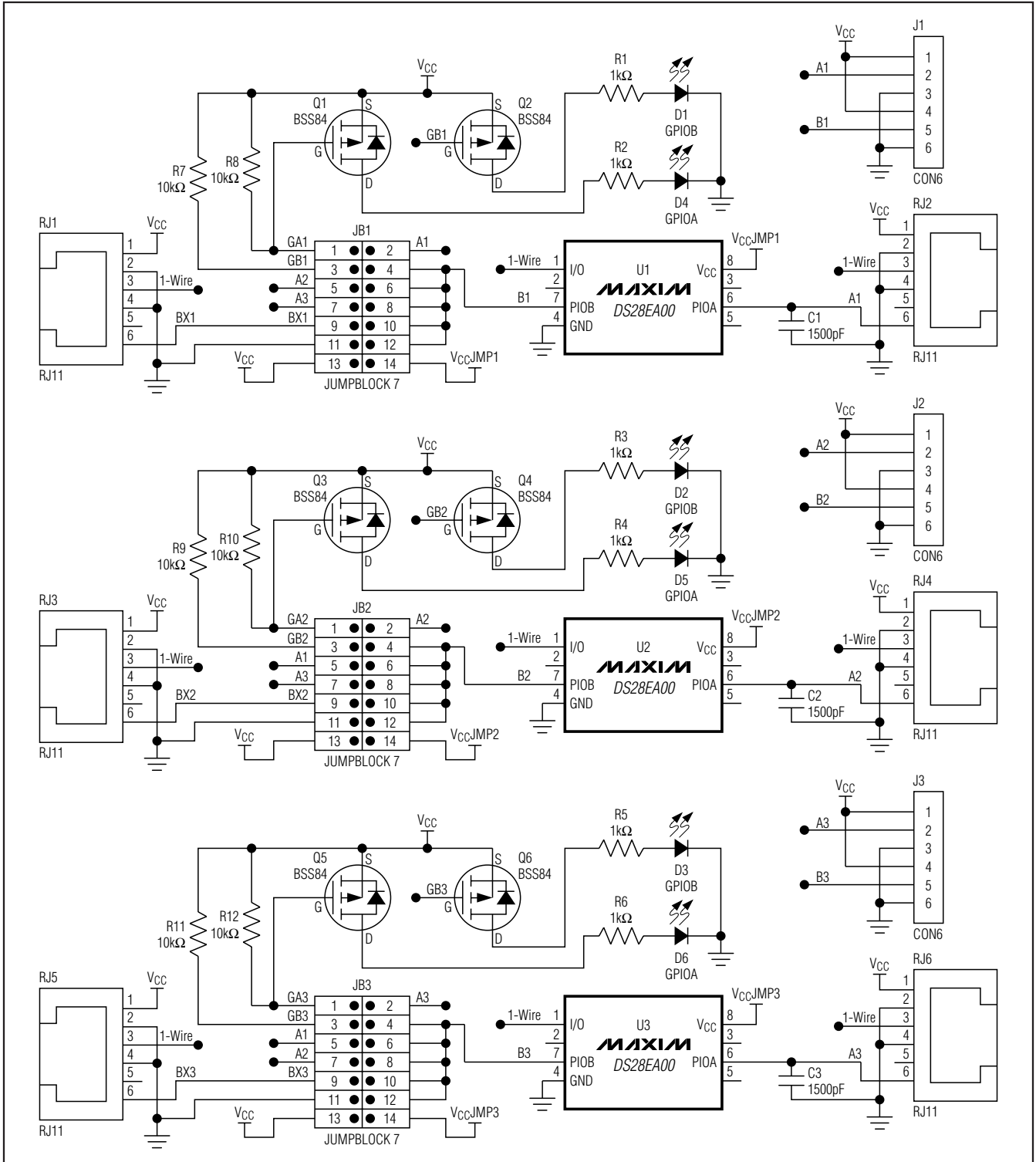

Figure 10. EV Board Schematics

DS28EA00 Evaluation Kit

Evaluates: DS28EA00

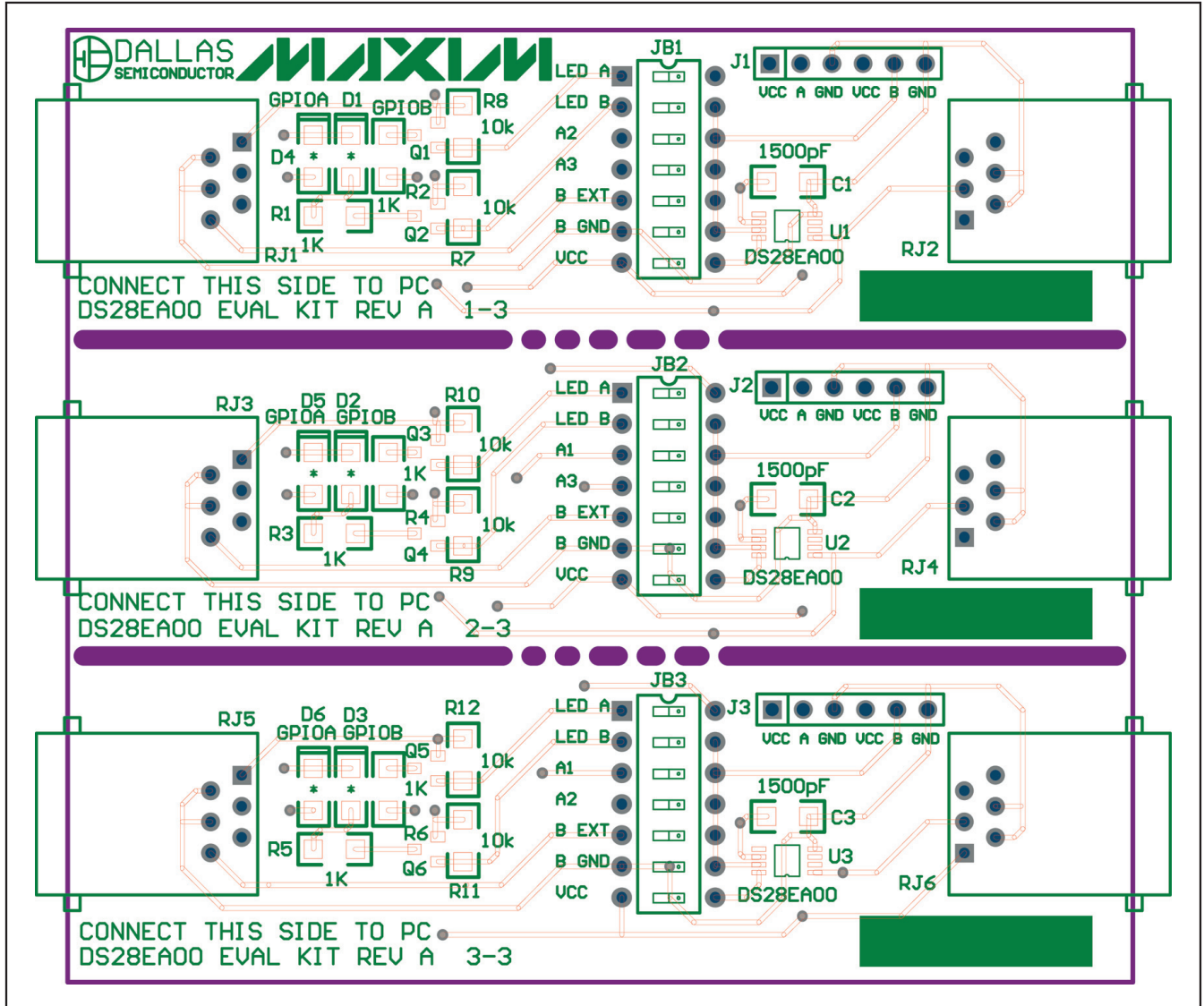

Figure 11. EV Board Layout Top

DS28EA00 Evaluation Kit

Evaluates: DS28EA00

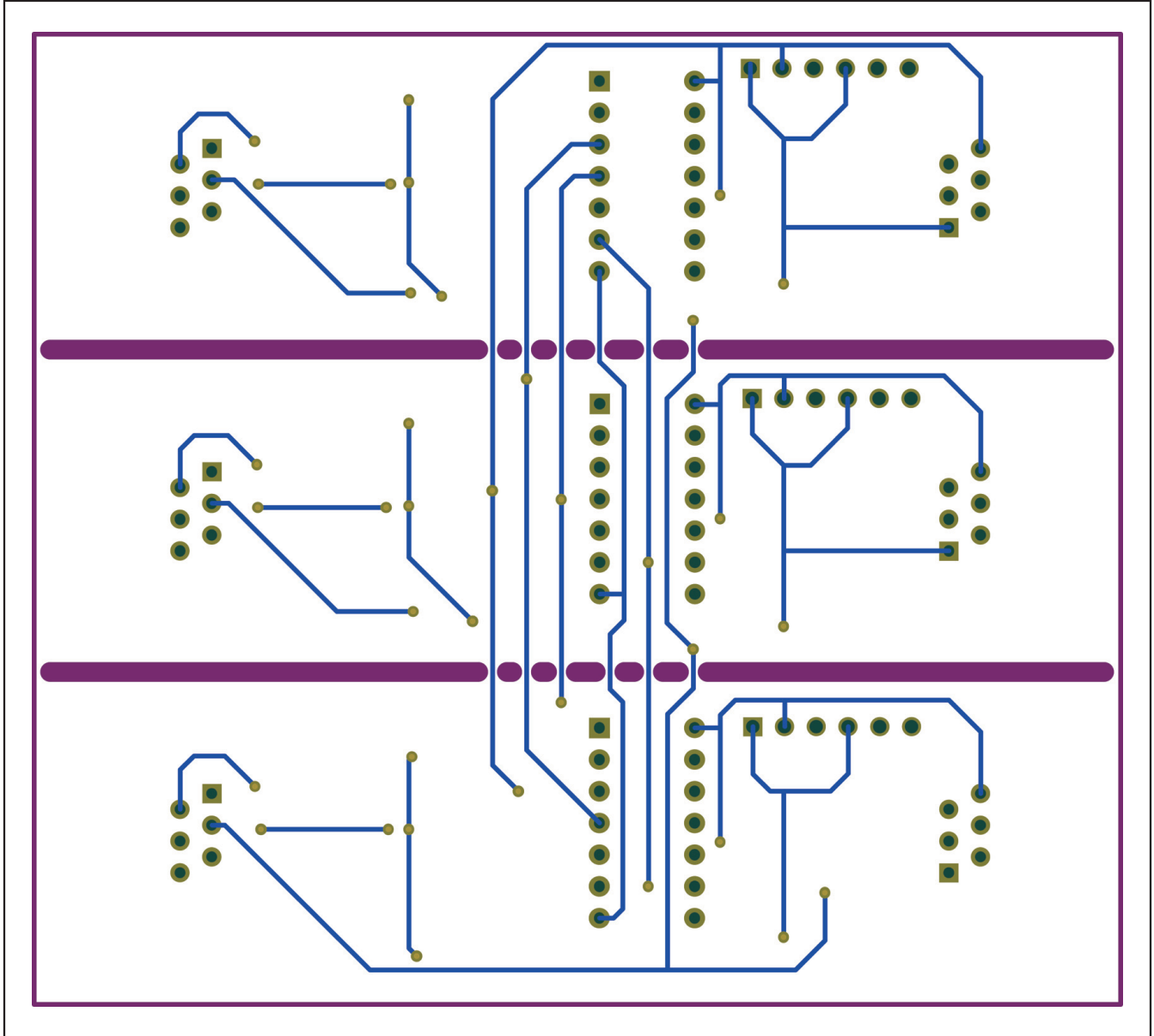

Figure 12. EV Board Layout Bottom

DS28EA00 Evaluation Kit

Evaluates: DS28EA00

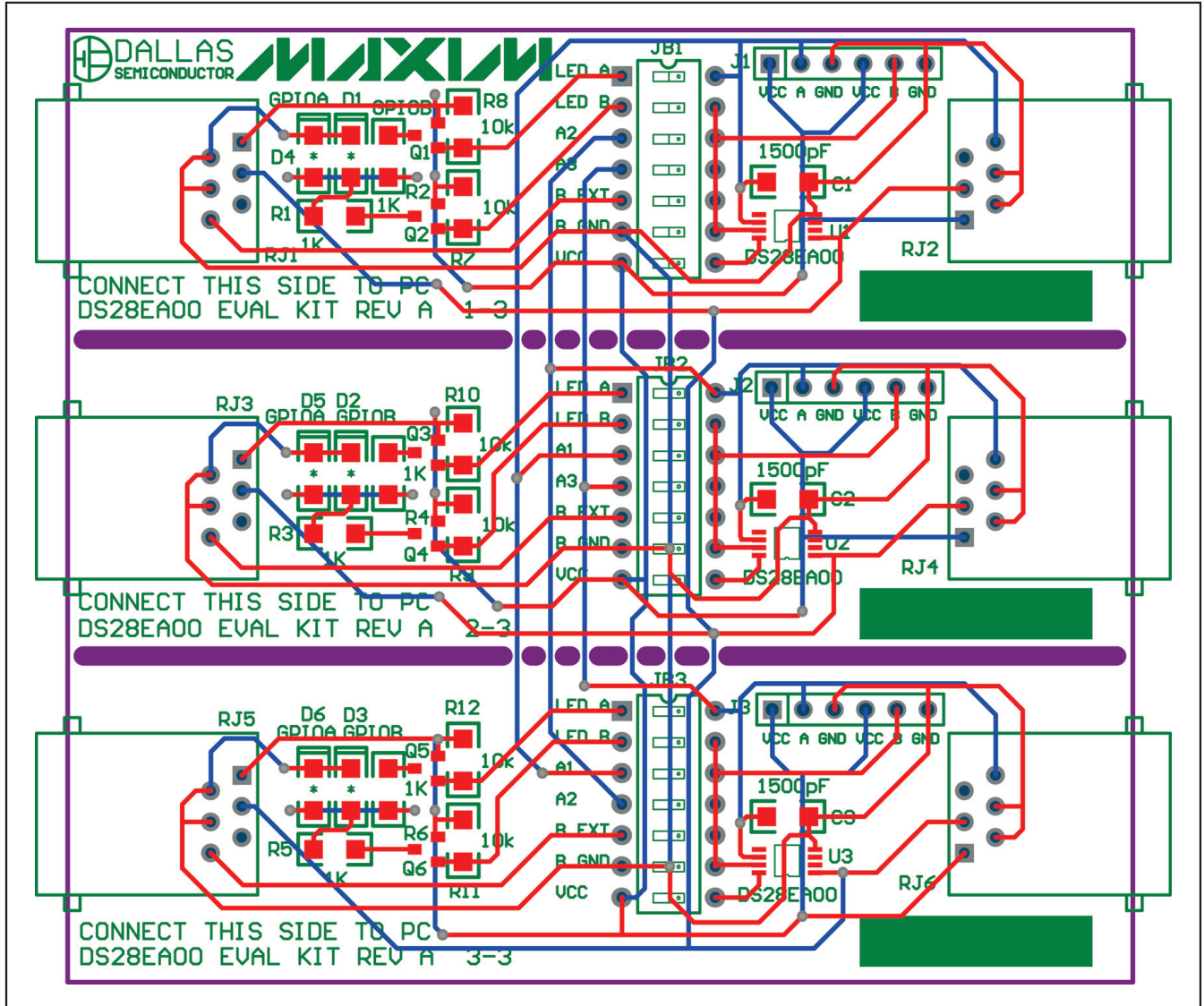

Figure 13. EV Board Layout Composite

Maxim cannot assume responsibility for use of any circuitry other than circuitry entirely embodied in a Maxim product. No circuit patent licenses are implied. Maxim reserves the right to change the circuitry and specifications without notice at any time.

Maxim Integrated Products, 120 San Gabriel Drive, Sunnyvale, CA 94086 408-737-7600 _____ 13

Looking for pricing, stock, or lifecycle information?

Click below to explore more details on WIN SOURCE:

-  [View DS28EA00EVKIT#](#) on WIN SOURCE
-  [Maxim Integrated](#) Information

Optimize Your Supply Chain with WIN SOURCE Solutions

-  Global Sourcing Solution
-  Obsolete Management
-  Cost Control Management
-  Shortage Management
-  Alternative Solution
-  Excess Inventory Management