



**THE DATASHEET OF
MAXM86146CFU+**



MAXM86146

Complete Optical Biosensing Module with Ultra-Low-Power Biometric Sensor Hub

General Description

The MAXM86146 is the world's smallest highly-integrated, optical data acquisition system. It combines Maxim's best-in-class optical biosensing analog front end (AFE) with a powerful Arm® microcontroller unit (MCU) and two high sensitivity photodiodes.

The integrated MCU is an ultra-low-power microcontroller specifically designed for battery-powered devices and wireless sensors. It combines a flexible and versatile power management unit that operates from a single 1.8V supply. It supports I²C communication protocol and is ready to be programmed with the latest firmware and world-class algorithms for wearable applications including pulse heart rate (HR), pulse blood oxygen saturation (SpO₂). The integrated algorithms adjust the optical AFE settings to maximize SNR while minimizing power consumption based on activity classification.

The optical AFE has two low-noise optical readout channels. Both channels have independent 19-bit ADCs and an industry-leading ambient light cancellation (ALC) circuit for unparalleled ambient-light rejection in many scenarios. The optical AFE includes three high-current, low-noise LED drivers and operates on a 1.8V main supply voltage and a flexible LED driver supply voltage.

With the addition of external LEDs and an accelerometer (required), a complete system is achieved reducing time to market and simplifying design. This arrangement seamlessly enables customer-desired on-chip processing, resulting in a highly-integrated sensor hub with embedded algorithms.

The MAXM86146 is available in a compact 4.5mm x 4.1mm x 0.88mm, 38-pin OLGA package and operates over commercial temperature range of 0°C to +70°C.

Applications

- Wearable Devices for Fitness and Wellness
- Optimized for Wrist, Finger, and Other Locations
- Optimized Performance to Detect
 - Pulse Heart Rate (HR)
 - Arterial Oxygen Saturation (SpO₂)

Benefits and Features

- Complete Biometric Sensor Hub
 - Supports Simultaneous Wrist-Based Pulse Heart Rate (WHRM) and Pulse Blood Oxygen Saturation (WSpO₂) Measurements
 - Integrated MAX86141 Dual-Channel Optical AFE
 - Integrated MAX32664C Arm® Cortex®-M4 based MCU
 - Two Integrated 3.8mm² PIN Photodiodes
 - Can Operate Independently (Two Channels)
 - Can Be Combined to Give a Total Radiant Area of 7.6mm² for Additional Flexibility
 - Excellent SNR Enables Measurements on a Wide Range of Users
 - Dynamic Range > 90dB in White Card Loop-Back Test (Sample-to-Sample Variance)
 - Dynamic Range Extendable to > 104dB for SpO₂ and > 110dB for HRM with Multiple Sample Modes and On-Chip Averaging
 - Convenient Solution Enables Faster Time-to-Market
 - Ultra-small 4.5mm x 4.1mm x 0.88mm, 38-Pin OLGA Package Size
- World-Class Algorithm for Wearable Applications
 - Supports Multiple Accelerometer Options to Allow Robust Detection and Rejection of Motion Artifacts
 - Both Raw and Processed Data are Available
 - FIFO Provides Minimal Host Interaction
 - Ultra-Low Power for Body Wearable Devices
 - AFE Only Requires 10µA Typical at 25sps
 - MCU Supports Deep-Sleep Mode, Allowing Device to Sleep Between Measurements.
 - Automatic Exposure Control (AEC) Algorithm Adjusts the Optical AFE Settings, Maximizing SNR while Minimizing Power Consumption

Ordering Information appears at end of datasheet.

Arm and Cortex are registered trademarks of Arm Limited



Simplified Block Diagram

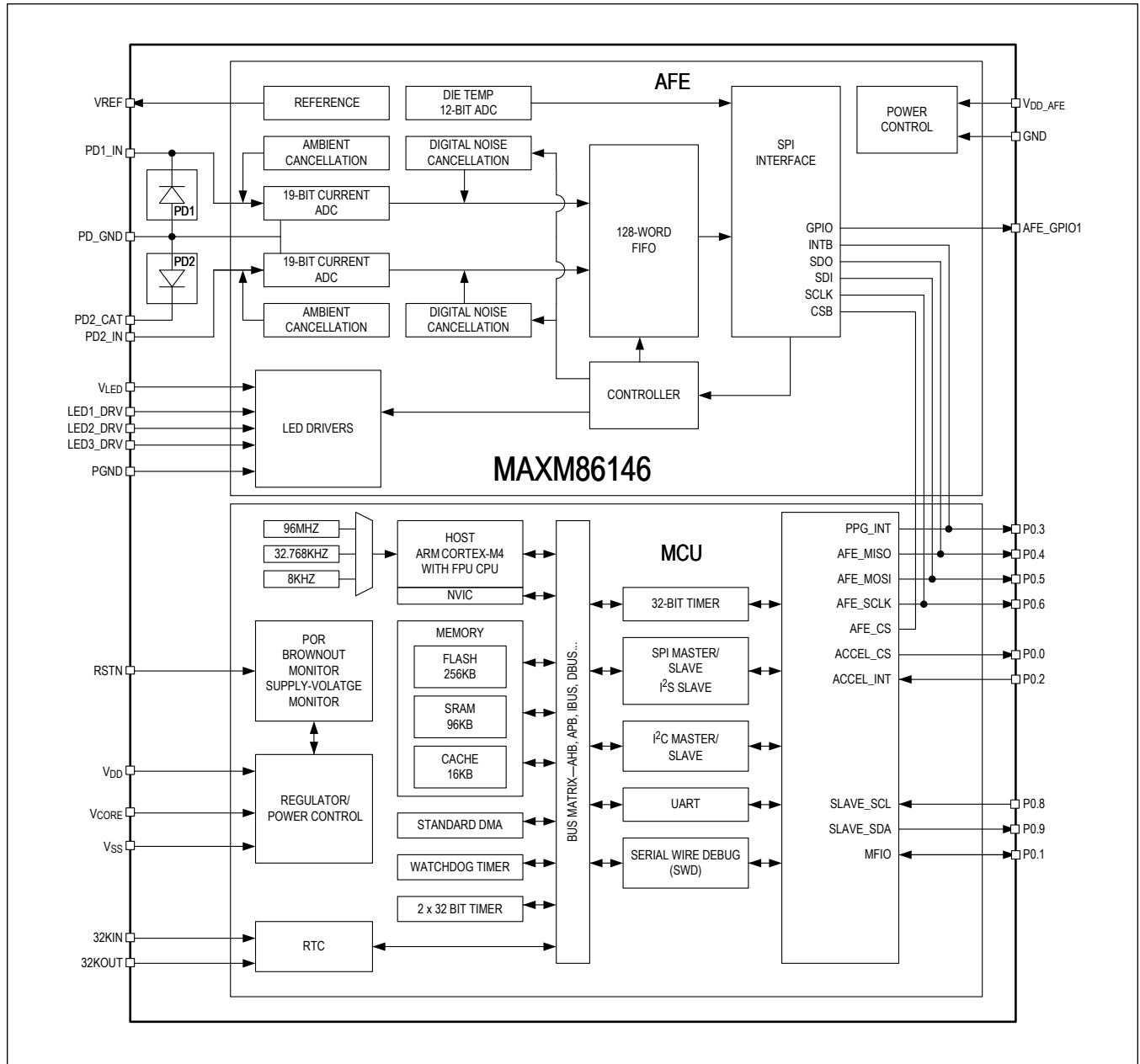

TABLE OF CONTENTS

General Description	1
Applications	1
Benefits and Features	1
Simplified Block Diagram	2
Absolute Maximum Ratings	5
Package Information	5
38-Pin OLGA	5
Electrical Characteristics	5
Pin Configuration	10
MAXM86146	10
Pin Description	11
Functional Block Diagrams	13
Diagram 1	13
Diagram 2	13
Detailed Description	14
Interface to Host (I ² C Interface)	14
Programming the Application Code	14
Heart-Rate and SpO ₂ Algorithm	15
Accelerometer Selection	15
V _{LED} Power Supply Considerations	15
LED Selection	16
Minimum V _{LED} Voltage	16
V _{LED} Bypass Capacitor Selection	16
Serial Peripheral Interface	16
I ² C	17
Device Selection	17
Typical Application Circuits	18
Application Circuit (WHRM + WSPO2)	18
Application Circuit 2 (WHRM)	19
Ordering Information	19
Revision History	20

LIST OF TABLES

Table 1. Recommended Accelerometer Details	15
Table 2. Pin Connection with Recommended Accelerometer	15
Table 3. Recommended LEDs	16

Absolute Maximum Ratings

V _{DD_AFE} to GND	-0.3V to +2.2V	PD_GND to GND	-0.3V to +0.3V
V _{DD} to V _{SS}	-0.3V to +3.6V	Total Current into All P0.x Combined (sink)	+100mA
V _{CORE} to V _{SS}	-0.3V to +1.2V	Output Current (sink) by Any P0.x Pin	+25mA
32KIN, 32KOUT to V _{SS}	-0.3V to V _{DD} + 0.3V	Output Current (source) by Any P0.x Pin	-25mA
RSTN, P0.x to V _{SS}	-0.3V to V _{DD} + 0.3V	V _{SS}	100mA
PDx_IN to PD_GND	-0.3V to +2.2V	Output Short-Circuit Duration	Continuous
PD_CAT to PD_GND	-0.3V to +6V	Continuous Input Current Into Any Pin (except LED_DRVx and P0.x Pins)	±20mA
V _{LED} to PGND	-0.3V to +6.0V	Operating Temperature Range	0°C to +70°C
LEDx_DRV to PGND	-0.3V to V _{LED} + 0.3V	Storage Temperature Range	-65°C to +150°C
V _{SS} to GND	-0.3V to +0.3V		
PGND to GND	-0.3V to +0.3V		

Stresses beyond those listed under "Absolute Maximum Ratings" may cause permanent damage to the device. These are stress ratings only, and functional operation of the device at these or any other conditions beyond those indicated in the operational sections of the specifications is not implied. Exposure to absolute maximum rating conditions for extended periods may affect device reliability.

Package Information

38-Pin OLGA

Package Code	F384A4+1
Outline Number	21-100323
Land Pattern Number	90-100112

For the latest package outline information and land patterns (footprints), go to www.maximintegrated.com/packages. Note that a "+", "#", or "-" in the package code indicates RoHS status only. Package drawings may show a different suffix character, but the drawing pertains to the package regardless of RoHS status.

Package thermal resistances were obtained using the method described in JEDEC specification JESD51-7, using a four-layer board. For detailed information on package thermal considerations, refer to www.maximintegrated.com/thermal-tutorial.

Electrical Characteristics

(V_{DD_AFE} = V_{DD} = 1.8V, V_{CORE} = 1.1V (generated from internal LDO; 1μF bypassed to V_{SS}), V_{LED} = 5.0V, T_A = +25°C, min/max are from T_A = -40°C to +85°C, unless otherwise noted.) (Note 1)

PARAMETER	SYMBOL	CONDITIONS	MIN	TYP	MAX	UNITS
MCU POWER SUPPLIES / OPERATION						
Supply Voltage	V _{DD}		1.71	1.8	3.63	V
Power-Fail Reset Voltage	V _{RST}	Monitors V _{DD}	1.63		1.71	V
Power-On Reset Voltage	V _{POR}	Monitors V _{DD}		1.4		V
MCU POWER SUPPLIES / SINGLE-SUPPLY OPERATION (V_{DD} ONLY)						
V _{DD} Fixed Current, Deep Sleep Mode	I _{DD_FDLSL}	Standby state with full data retention and 96kB SRAM retained		4.2		μA
AFE POWER SUPPLIES						
Power Supply Voltage	V _{DD_AFE}		1.7	1.8	2.0	V
LED Supply Voltage	V _{LED}		3.1		5.5	V
V _{DD_AFE} Current in Shutdown		T _A = +25°C		0.6	3.0	μA
V _{LED} Current in Shutdown		T _A = +25°C			1	μA

Electrical Characteristics (continued)

($V_{DD_AFE} = V_{DD} = 1.8V$, $V_{CORE} = 1.1V$ (generated from internal LDO; $1\mu F$ bypassed to V_{SS}), $V_{LED} = 5.0V$, $T_A = +25^\circ C$, min/max are from $T_A = -40^\circ C$ to $+85^\circ C$, unless otherwise noted.) (Note 1)

PARAMETER	SYMBOL	CONDITIONS	MIN	TYP	MAX	UNITS
MCU / GENERAL-PURPOSE I/O						
Input-Low Voltage for RSTN, GPIO P0.1, P0.2, P0.3	V_{IL_GPIO}				$0.3 \times V_{DD}$	V
Input-High Voltage for RSTN, GPIO P0.1, P0.2, P0.3	V_{IH_GPIO}		$0.7 \times V_{DD}$			V
Output-Low Voltage for GPIO P0.0, P0.1	V_{OL_GPIO}	$I_{OL} = 2mA$		0.2	0.4	V
Output-High Voltage for GPIO P0.0, P0.1	V_{OH_GPIO}	$I_{OH} = 2mA$	$V_{DD} - 0.4$			V
Input Hysteresis (Schmitt)	V_{IHYS}			300		mV
Input/Output Pin Capacitance for All Pins	C_{IO}			4		pF
Input Leakage Current Low	I_{IL}		-500		+500	nA
Input Leakage Current High	I_{IH}		-500		+500	nA
Input Pullup Resistor to RSTN	R_{PU_VDD}	Pullup to $V_{DD} = 1.62V$		22		k Ω
		Pullup to $V_{DD} = 3.6V$		10.5		
Input Pullup Resistor for All GPIO P0.x	R_{PU}	Pullup to $V_{DD} = 1.62V$		22		k Ω
		Pullup to $V_{DD} = 3.63V$		10.5		
Input Pulldown Resistor for All GPIO P0.x	R_{PD}	Pulldown to V_{SS} , $V_{DD} = 1.62V$		20		k Ω
MCU / FLASH MEMORY						
Flash Erase Time	t_{M_ERASE}	Mass erase		30		ms
	t_{P_ERASE}	Page erase		30		
Flash Programming Time Per Word	t_{PROG}			60		μs
Flash Endurance			10			kCYCLES
Data Retention	t_{RET}	$T_A = +85^\circ C$	10			YEARS
MCU / IO BUSES / SPI / MASTER MODE						
Input-Low Voltage for GPIO SPI P0.4	V_{IL_SPI}		V_{SS}		$0.3 \times V_{DD}$	V
Input-High Voltage for GPIO SPI P0.4	V_{IH_SPI}		$0.7 \times V_{DD}$		V_{DD}	V
Output-Low Voltage for GPIO SPI P0.5, P0.6	V_{OL_SPI}	$I_{OL} = 2mA$			0.4	V
Output-High Voltage for GPIO SPI P0.5, P0.6	V_{OH_SPI}	$I_{OH} = 2mA$	$V_{DD} - 0.4$			V

Electrical Characteristics (continued)

($V_{DD_AFE} = V_{DD} = 1.8V$, $V_{CORE} = 1.1V$ (generated from internal LDO; $1\mu F$ bypassed to V_{SS}), $V_{LED} = 5.0V$, $T_A = +25^\circ C$, min/max are from $T_A = -40^\circ C$ to $+85^\circ C$, unless otherwise noted.) (Note 1)

PARAMETER	SYMBOL	CONDITIONS	MIN	TYP	MAX	UNITS
SPI Master Operating Frequency	f_{MCK}				48	MHz
SPI Master SCLK Period	t_{MCK}			$1/f_{MCK}$		ns
SCLK Output Pulse-Width High/Low	t_{MCH} , t_{MCL}		$t_{MCK}/2$			ns
MOSI Output Hold Time After SCLK Sample Edge	t_{MOH}		$t_{MCK}/2$			ns
MOSI Output Valid to Sample Edge	t_{MOV}		$t_{MCK}/2$			ns
MISO Input Valid to SCLK Sample Edge Setup	t_{MIS}			5		ns
MISO Input to SCLK Sample Edge Hold	t_{MIH}			$t_{MCK}/2$		ns
MCU / IO BUSES / I²C / FAST MODE						
Input-Low Level Voltage for GPIO I ² C P0.8, P0.9	V_{IL_I2C}				$0.3 \times V_{DD}$	V
Input-High Level Voltage for GPIO I ² C P0.8, P0.9	V_{IH_I2C}		$0.7 \times V_{DD}$			V
Output-Low Level Voltage for GPIO I ² C P0.8, P0.9	V_{OL_I2C}	$I_{OL_I2C} = 2mA$		0.2	0.4	V
Output-High Level Voltage for GPIO I ² C P0.8, P0.9	V_{OH_I2C}	$I_{OH_I2C} = 2mA$	$V_{DD} - 0.4$			V
Output Fall Time	t_{OF}	From $V_{OH_I2C(MIN)}$ to $V_{OL_I2C(MAX)}$		150		ns
Pulse Width Suppressed by Input Filter	t_{SP}			75		ns
SCL Clock Frequency	f_{SCL}		0		400	kHz
Low-Period SCL Clock	t_{LOW}		1.3			μs
High-Time SCL Clock	t_{HIGH}		0.6			μs
Setup Time for Repeated Start Condition	t_{SU_STA}		0.6			μs
Hold Time for Repeated Start Condition	t_{HD_STA}		0.6			μs
Data Setup Time	t_{SU_DAT}			125		ns
Data Hold Time	t_{HD_DAT}			10		ns
Rise Time for SDA and SCL	t_R			30		ns

Electrical Characteristics (continued)

($V_{DD_AFE} = V_{DD} = 1.8V$, $V_{CORE} = 1.1V$ (generated from internal LDO; $1\mu F$ bypassed to V_{SS}), $V_{LED} = 5.0V$, $T_A = +25^\circ C$, min/max are from $T_A = -40^\circ C$ to $+85^\circ C$, unless otherwise noted.) (Note 1)

PARAMETER	SYMBOL	CONDITIONS	MIN	TYP	MAX	UNITS
Fall Time for SDA and SCL	t_F			30		ns
Setup Time for a Stop Condition	t_{SU_STO}		0.6			μs
Bus-Free Time Between a Stop and Start Condition	t_{BUS}		1.3			μs
Data Valid Time	t_{VD_DAT}		0.9			μs
Data Valid Acknowledge Time	t_{VD_ACK}		0.9			μs
AFE / READOUT CHANNEL						
ADC Resolution				19		BITS
Maximum ADC Full-Scale Input Current				32.0		μA
Minimum ADC Integration Time	t_{INT}			14.8		μs
Maximum ADC Integration Time	t_{INT}			117.3		μs
Sample Rate Error		From nominal			± 2.5	%
Maximum DC Ambient Light Input Range	ALR			100		μA
AC Ambient Light Rejection	AC_ALRR	$I_{AMBIENT} = 1\mu A$ DC with $\pm 0.4\mu A_{p-p}$ 120Hz sine wave		70		dB
DC Ambient Light Rejection		$I_{AMBIENT}$ modulated between $0\mu A$ and $30\mu A$, ADC integration time = $117.3\mu s$		0.5		nA
Dark Current Input Referred Noise		ADC integration time = $14.8\mu s$		262		pA_{RMS}
		ADC integration time = $117.3\mu s$		56		pA_{RMS}
Maximum Photodiode Input Capacitance	C_{PD}			65		pF
V_{DD} DC PSR		$I_{AMBIENT} = 0\mu A$, $V_{DD} = 1.7V$ to $2.0V$, $T_A = +25^\circ C$	-560	-330	+560	LSB/V
AFE / LED Driver						
LED Current Resolution				8		BITS
Full-Scale LED Current	I_{LED}	Maximum configurable LED current	114	124	132	mA
Minimum Output Voltage	V_{OL}	Full-scale LED current		700		mV
LED Driver DC PSR		$V_{DD_AFE} = 1.8V$, $V_{LEDx_DRV} = 0.9V$, $V_{LED} = 3.1V$ to $5.5V$, $I_{LED} = 124mA$, $T_A = +25^\circ C$		-1	+400	$\mu A/V$
		$V_{DD_AFE} = 1.7V$ to $2.0V$, $T_A = +25^\circ C$, $I_{LED} = 124mA$		150	1500	

Electrical Characteristics (continued)

($V_{DD_AFE} = V_{DD} = 1.8V$, $V_{CORE} = 1.1V$ (generated from internal LDO; $1\mu F$ bypassed to V_{SS}), $V_{LED} = 5.0V$, $T_A = +25^\circ C$, min/max are from $\bar{T}_A = -40^\circ C$ to $+85^\circ C$, unless otherwise noted.) (Note 1)

PARAMETER	SYMBOL	CONDITIONS	MIN	TYP	MAX	UNITS
PHOTODIODE						
Wavelength of Peak Sensitivity				860		nm
Spectral Bandwidth Range				420 to 1020		nm

Note 1: All devices are 100% production tested at $T_A = +25^\circ C$. Specifications over temperature limits are guaranteed by Maxim Integrated's bench or proprietary automated test equipment (ATE) characterization.

Pin Configuration

MAXM86146

TOP VIEW

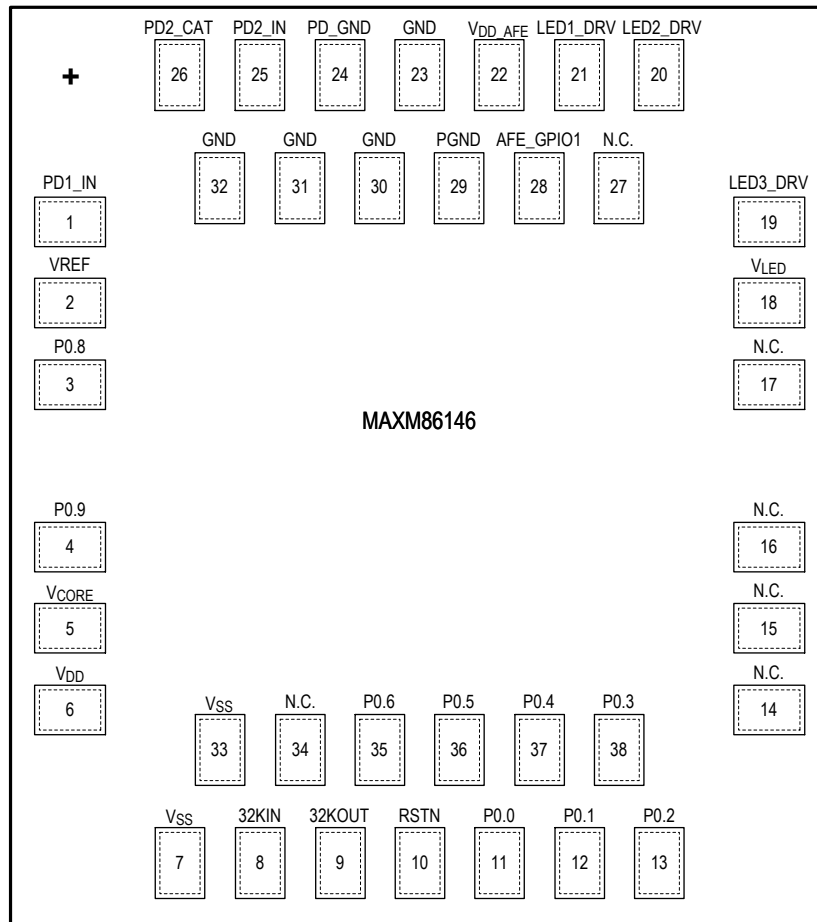

38L-PIN OLGA
4.5mm x 4.1mm x 0.88mm

Pin Description

PIN	NAME	FUNCTION
POWER		
5	V _{CORE}	MCU Core Supply Voltage. This pin provides dual supply operation to support PMIC-based systems and should be left open-circuit for single supply operation. This pin must always be bypassed to V _{SS} with a 1.0µF capacitor as close as possible to the package regardless of the supply mode of operation.
6	V _{DD}	MCU Digital Supply Voltage. This pin must be bypassed to V _{SS} with a 1.0µF capacitor as close as possible to the package. The device can operate solely from this one power supply pin without the need to connect V _{CORE} by utilizing the internal V _{CORE} regulator. The internal V _{CORE} regulator automatically operates if the presence of a voltage on the V _{CORE} pin is not detected. This provides single-supply-battery operation capability.
7, 33	V _{SS}	MCU Digital Ground. Connect to GND.
18	V _{LED}	LED Power Supply Input. Connect to an external voltage supply. Bypass with a 10µF and 0.1µF capacitor to PGND.
22	V _{DD_AFE}	AFE Power Supply Input. Connect to an externally-regulated supply. Bypass with a 0.1µF capacitor as close as possible to pad and a 10µF capacitor to GND.
23,30,31,32	GND	AFE Power Supply Return. Connect to GND.
29	PGND	LED Power Return. Connect to PGND.
REFERENCE		
2	VREF	Internal reference decoupling point. Bypass with a 1.0µF capacitor to GND.
OPTICAL PINS		
1	PD1_IN	Photodiode Cathode Input (CH1)
25	PD2_IN	Photodiode Cathode Input (CH2)
26	PD2_CAT	Cathode of Photodiode2 (PD2)
24	PD_GND	Photodiodes Anode. Connect to GND.
21	LED1_DRV	LED Output Driver 1. Connect the LED cathode to LED1_DRV and its anode to the V _{LED} supply.
20	LED2_DRV	LED Output Driver 2. Connect the LED cathode to LED2_DRV and its anode to the V _{LED} supply.
19	LED3_DRV	LED Output Driver 3. Connect the LED cathode to LED3_DRV and its anode to the V _{LED} supply.
RESET		
10	RSTN	Hardware Power Reset (Active-Low) Input. The device remains in reset while this pin is in its active state. When the pin transitions to its inactive state, the device performs a POR reset (resetting all logic on all supplies except for real-time clock circuitry) and begins execution. This pin is internally connected with an internal pullup to the V _{DD} supply as indicated in the Electrical Characteristics table. This pin should be left unconnected if the system design does not provide a reset signal to the device.
GENERAL-PURPOSE I/O		
11	P0.0	Accelerometer SPI Chip Select (ACCEL_CS). Connect this pin to the KX122 Accelerometer SPI CS pin.
12	P0.1	Multifunction IO (MFIO). This pin provides different functions: MFIO asserts low as an output when the sensor hub needs to communicate with the host controller; the pin acts as an input and causes the sensor hub to enter bootloader mode if the MFIO pin is low during a reset.
13	P0.2	Accelerometer Interrupt (ACCEL_INT). Connect this pin to the KX122 Accelerometer INT pin.
38	P0.3	Optical AFE Interrupt Input (PPG_INT). This pin is tied to the connection between the Optical AFE interrupt and the MCU. Tie an external pullup resistor to V _{DD} .

Pin Description (continued)

PIN	NAME	FUNCTION
37	P0.4	SPI Master In/Slave Out (MISO). Connect this to the KX122 Accelerometer SDO pin. This pin is also connected to the AFE SDO pin. Refer to the Typical Application Circuit.
36	P0.5	SPI Master Out/Slave In (MOSI). Connect this to the KX122 Accelerometer SDI pin. This pin is also connected to the AFE SDI pin. Refer to the Typical Application Circuit.
35	P0.6	SPI Master Serial Clock (SCLK). Connect this to the KX122 Accelerometer SCLK pin. This pin is also connected to the AFE SCLK pin. Refer to the Typical Application Circuit.
3	P0.8	I ² C Slave Clock. This is the I ² C slave SCL that should be connected to the host microprocessor I ² C master SCL. Pullup resistor to V _{DD} is required.
4	P0.9	I ² C Slave Data. This is the I ² C slave SDA that should be connected to the host microprocessor I ² C master SDA. Pullup resistor to V _{DD} is required.
28	AFE_GPIO1	General Purpose I/O. Open-drain when programmed as output (active low). Drives Select pin on (optional) External LED MUX. If external LED MUX is not used, set as N.C.
CLOCK		
8	32KIN	32.768kHz Crystal Oscillator Input. Connect a 6pF 32.768kHz watch crystal, CL = 6pF, ESR < 90kΩ, C0 < 2pF crystal between 32KIN and 32KOUT for normal operation. Optionally, an external clock source can be driven on 32KIN if the 32KOUT pin is left unconnected.
9	32KOUT	32.768kHz Crystal Oscillator Output. Connect a 6pF 32.768kHz watch crystal, CL = 6pF, ESR < 90kΩ, C0 < 2pF crystal between 32KIN and 32KOUT for normal operation. Optionally, an external clock source can be driven on 32KIN if the 32KOUT pin is left unconnected.
N.C.		
14, 15, 16, 17, 27, 34	N.C.	Not Connected. Connect to unconnected PCB pad for mechanical stability. N.C. pins should not be connected to any signal, power, or ground pins.

Functional Block Diagrams

Diagram 1

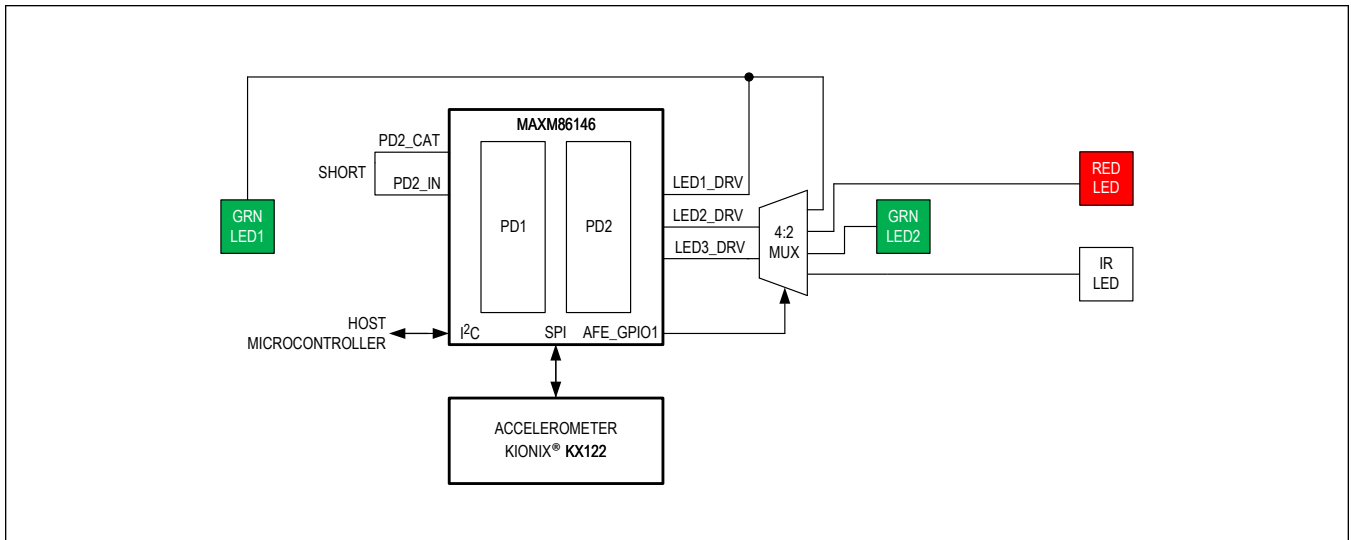
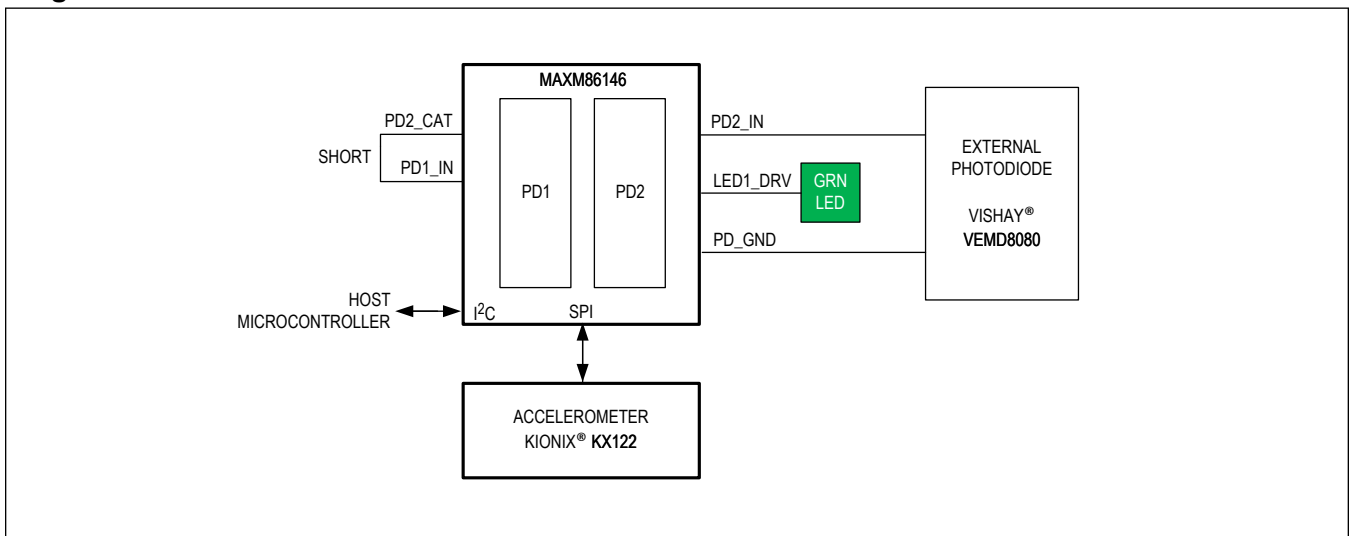

Diagram 2



KIONIX is a registered trademark of KIONIX, Inc. Corporation
Vishay is a registered trademark of Vishay Intertechnology, Inc.

Detailed Description

The MAXM86146 is a sensor hub with embedded firmware and algorithms for wearables that seamlessly enables customer-desired on-chip processing. This highly integrated sensor hub with embedded algorithms simplifies the design-in process by delivering raw or calculated data to the outside world in an ultra-small form factor. This is achieved by minimizing the overall system power consumption while maintaining enough SNR to allow a large variety of users and body locations to be measured quickly and accurately.

Wearable health and fitness solutions are increasingly space and power constrained. These optical solutions need to maintain proper LED and PD separation distances to maximize the optical PPG signals received in order to calculate heart rate and SpO₂. The longer wavelengths needed for SpO₂ travel longer paths compared to the shorter path and wavelength that HRM requires. The MAXM86146 uses accelerometer data to compensate for periodic motion artifacts and is optimized for two simultaneous green PPG signals. These two green PPG signals can be achieved by either 2 x PD / 1 x LED or 1 x PD / 2 x LED. SpO₂ requires the use of two different LED wavelengths, namely red and IR. They need to share the same photodiode and separation distance. The MAXM86146 can be configured for simultaneous HRM and SpO₂ measurements with the addition of an external DPDT MUX, such as the MAX14689, for its low noise performance. If only HRM is desired, the MAXM86146 has the option to be configured to use an external photodiode, allowing for a single green LED to be used. This versatility makes it easy to integrate optical heart-rate monitoring and SpO₂ measurements into any wearable application by offering the flexibility to support multiple optical configurations, and on-chip processing.

The device connects to a microcontroller host through a fast-mode slave I²C interface, allows for in-field updates, and provides access to raw data and processed algorithm calculations. With the addition of external LEDs and an accelerometer (either direct-connected or host-connected is required), a complete system is achieved reducing time-to-market and simplifying design. Additionally, the Maxim Integrated biometric sensor hub provides additional features such as industry leading ambient light rejection, higher signal-to-noise (SNR) ratio compared to the competition, and enters ultra-low-power deep sleep mode between samples. The MAXM86146 is shipped with bootloader software that accepts in-application programming of Maxim proprietary application code, and is designed to be used only with this application code. The application code consists of advanced algorithms, AFE controller, and an accelerometer controller. The latest application code can be downloaded from the [MAXM86146](#) product page under the Design Resource tab.

Interface to Host (I²C Interface)

The interface to the host is the I²C interface. It is a bidirectional, two-wire serial bus that provides a versatile medium-speed communications network. It can operate as a one-to-one, one-to-many, or many-to-many communication mediums. These engines support fast-mode I²C speeds. The devices support one slave interface (address 0x55—refer to the [MAX32664 User Guide](#)). The features for this interface are:

- One slave for communication with a host
- Supports standard 7-bit addressing or 10-bit addressing
- Restart conditions
- Interactive receive mode
- Tx FIFO preloading
- Support for clock stretching to allow slower slave devices to operate on higher speed buses
- Fast mode: 400kbps
- Internal filter to reject noise spikes
- Receiver FIFO depth of 8 bytes
- Transmitter FIFO depth of 8 bytes

Programming the Application Code

The MAXM86146 ships with a bootloader that is ready to be programmed with the latest application code over the I²C communication bus. The application code contains the firmware and algorithms (version C), which controls the AFE, allowing simple communication through I²C commands. The MAX32664 bootloader firmware supports in-application programming (IAP). The MAX32664 is a variant of the MAX32660. Refer to the latest [MAX32660 Bootloader User Guide](#)

for the complete programming procedure that can also be found at the [MAXM86146](#) product page under the Design Resource tab.

For I²C programming, the following pins are required:

- RSTN
- P0.1 (MFIO)
- P0.8 (SCL)
- P0.9 (SDA)

Heart-Rate and SpO₂ Algorithm

The integrated MAX32664C MCU within the MAXM86146 supports a wrist-based (Version C) Algorithm that communicates with the MAX86141 Optical AFE through a master-mode SPI interface to perform wrist-based pulse heart-rate and pulse blood-oxygen saturation (SpO₂) measurements. The embedded algorithm uses digital filtering, distance/motion compensation, and advanced R-wave detection to determine the pulse rate in beats per minute. SpO₂ results are reported as a percentage of hemoglobin that is saturated with oxygen. The calibration values for SpO₂ configuration should be determined while using the end product, as changes in optical or mechanical design can effect the calibration. Power usage is minimized with automatic power-minimized gain control. For more information, see the latest [MAX32664 User Guide](#). Additional supporting documentation that can also be found by visiting the [MAXM86146](#) product page under the Design Resource tab.

Accelerometer Selection

The firmware of the MAXM86146 supports the accelerometer in [Table 1](#) connected directly to the SPI bus. Pin-to-pin connections between MAXM86146 and the recommended accelerometer are given in [Table 2](#). If a host-connected Accelerometer is desired, refer to the latest [MAX32664 User Guide](#). For more detailed descriptions and requirements, refer to the [MAXM86146](#) product page under the Design Resources tab.

Table 1. Recommended Accelerometer Details

MANUFACTURER	PART NUMBER	DESCRIPTION	PACKAGE
Kionix	KX122-1037	±2g/±4g/±8g Tri-axis Digital Accelerometer	2mm x 2mm x 0.9mm LGA

Table 2. Pin Connection with Recommended Accelerometer

MAXM86146 PIN (DESCRIPTION)	KIONIX KX122 PIN
P0.0 (ACCEL_CS)	CS
P0.2 (ACCEL_INT)	INT
P0.4 (MISO)	SDO
P0.5 (MOSI)	SDI
P0.6 (SCK)	SCLK

V_{LED} Power Supply Considerations

Keeping the ripple on the V_{LED} line as low as possible ensures the highest SNR is reached. The V_{LED} power supply should not exceed a peak-to-peak ripple of 30mV, and the switching frequency should stay between 100kHz to 3MHz. Together with a good load transient response, where the ripple tends to be the highest, high SNR can be maintained at the heaviest loads.

The [MAX20345 PMIC with Ultra-Low IQ Voltage Regulators, Buck-Boost for Optical Sensing and Charger for Small Lithium Ion Systems](#) or the smaller [MAX20343 Ultra-Low Quiescent Current Low Noise 3.5W Buck-Boost Regulator](#), are recommended solutions for this application. They both offer a highly efficient buck-boost regulator with very small load ripple, fast load transient responses, and have load pulse consistencies that together, enable > 90dB SNR (white card loop-back test). For the latest PMIC and switching regulator products, visit: <https://www.maximintegrated.com/en/products/power/power-management-ics>

LED Selection

The MAXM86146 integrates three precision LED-driver-current DACs that modulate LED pulses for a variety of optical measurements. The LED current DACs have 8 bits of dynamic range with three programmable full-scale ranges of 124mA, each. The LED drivers are low dropout current sources allowing for low-noise, power-supply-independent LED currents to be sourced at the lowest supply voltage possible, minimizing LED power consumption. The LED pulse width can be programmed from 14.8 μ s to 117.3 μ s, allowing the algorithms to optimize SpO₂ and HR accuracy at the lowest dynamic power consumption dictated by the application. The typical V_{LED} voltage of 5.0V for the recommended LEDs in [Table 3](#) are selected for their low forward voltage, high light output, radiation pattern and specific peak wavelength, enabling exceptional WSpO₂ and WHRM performance.

Table 3. Recommended LEDs

USE CASE	MANUFACTURER	PART NUMBER	DESCRIPTION	LED
WHRM	OSRAM®	CT DBLP31.12	FIREFLY® E2218	GREEN
WSPO2	OSRAM	SFH 7015	CHIPLED® SFH 7015	RED/GREEN/IR

CHIPLED, FIREFLY, and OSRAM are registered EU trademarks of OSRAM GmbH.

Minimum V_{LED} Voltage

The V_{LED} voltage must consider the forward voltage (V_F) of the LEDs driven at the 132mA current. The sum of V_F of the LED at I_{LED} = 132mA and the 900mV LED driver headroom must be considered. Additionally, the AFE requires a minimum of 3.1V applied to the V_{LED} pin.

The V_{LED} voltage must be above this minimum to avoid compression, and allow for enough headroom to supply the current of 124mA (typical) and 132mA (max); otherwise, the I_{LED} is reduced and sensitive to V_{LED} supply changes. LEDx_DRV pins can be measured during an exposure to ensure the 900mV minimum voltage is maintained during each LED exposure. This is simplified using the formula:

$$V_{LED} \geq V_F + 900\text{mV} \geq 3.1\text{V}$$

where, V_F is a function of I_{LED} when driven with 134mA (max). Alternatively, LED should be selected so that: V_F ≤ V_{LED} - 900mV.

V_{LED} Bypass Capacitor Selection

V_{LED} bypass capacitor selection criteria requires careful consideration of effective capacitance of a capacitor at an applied DC voltage. The typical 0603 sized (0.6mm x 0.3mm) 10 μ F capacitor rated for 16V typically derates to ≤ 4 μ F effective capacitance at a 5.0V DC-bias voltage. The applied DC voltage, with respect to the DC rating of a capacitor with a small physical size, reduces the actual (effective) capacitance that the component can supply. Therefore, a minimum of 4 μ F of effective capacitance is recommended for all V_{LED} bypass capacitors at any package size. All ceramic capacitors with high dielectric constants (X5R, X7R) derate significantly; therefore, derating must be considered when selecting a V_{LED} bypass capacitors at reduced footprint sizes. To aid in the selection process and when considering derating as well as minimum PCB footprint, the following 22 μ F 0402 X5R 6.3V GRM155R60J226ME11 capacitor manufactured by muRata® should be used. This component is specifically recommended for use on this design as it maintains the similar performance as its larger counterparts at a smaller package size.

muRata is a registered trademark of Murata Manufacturing Co., Ltd. Corporation.

Serial Peripheral Interface

The Serial Peripheral Interface (SPI) is a highly configurable, flexible, and efficient synchronous interface between multiple SPI devices on a single bus. The bus uses a single clock signal and multiple data signals, and one or more slave select lines to address only the intended target device. The SPI operates independently and requires minimal processor overhead.

I²C

A master I²C interface is a bidirectional, two-wire serial bus that provides a medium-speed communications network. It can operate as a one-to-one, one-to-many, or many-to-many communication mediums. These engines support fast-mode I²C speeds. Pullup resistors are required for this interface.

Device Selection

Refer to the Ordering Information at the end of this data sheet.

Typical Application Circuits

Application Circuit (WHRM + WSP02)

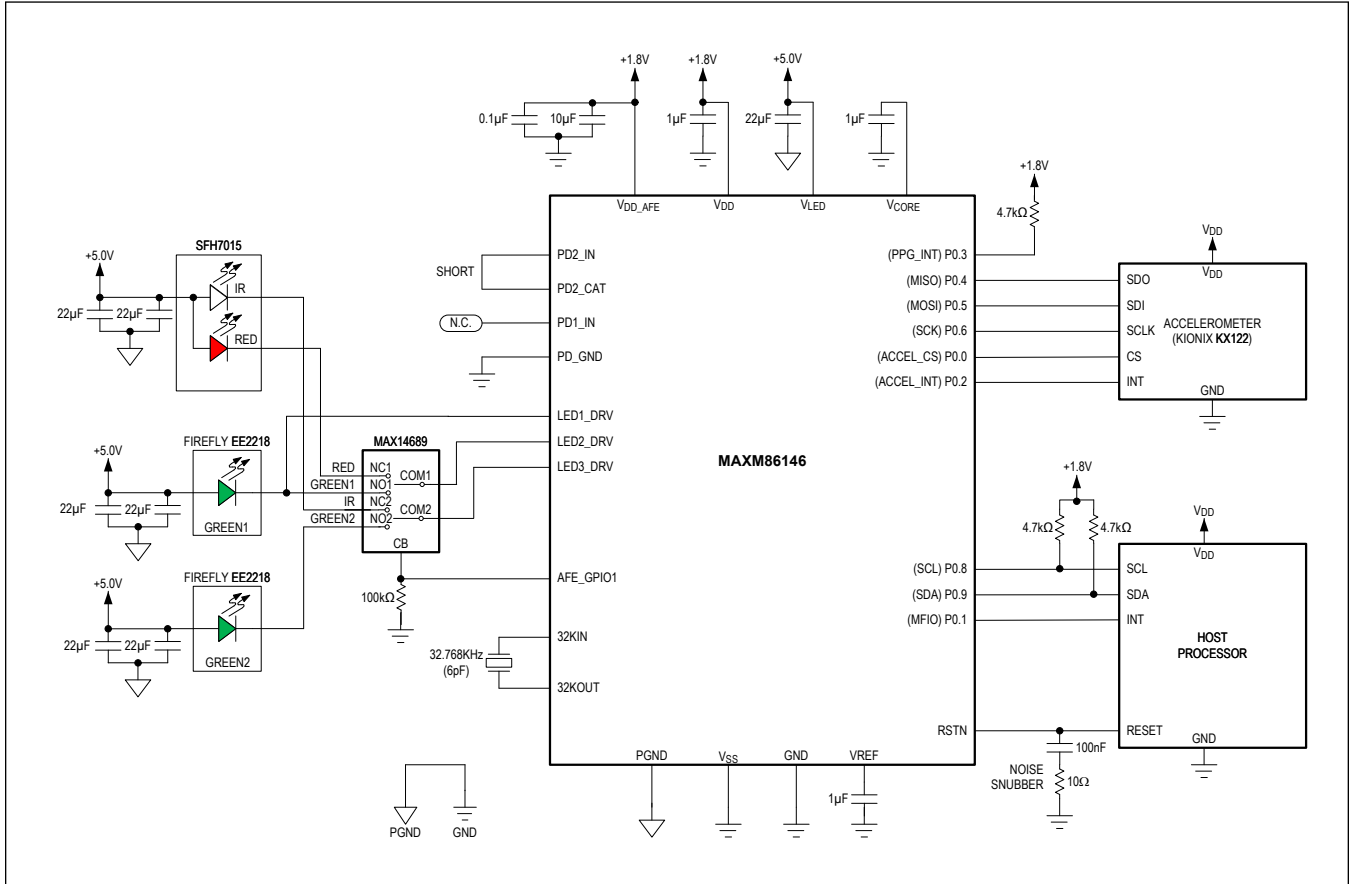

Typical Application Circuits (continued)

Application Circuit 2 (WHRM)

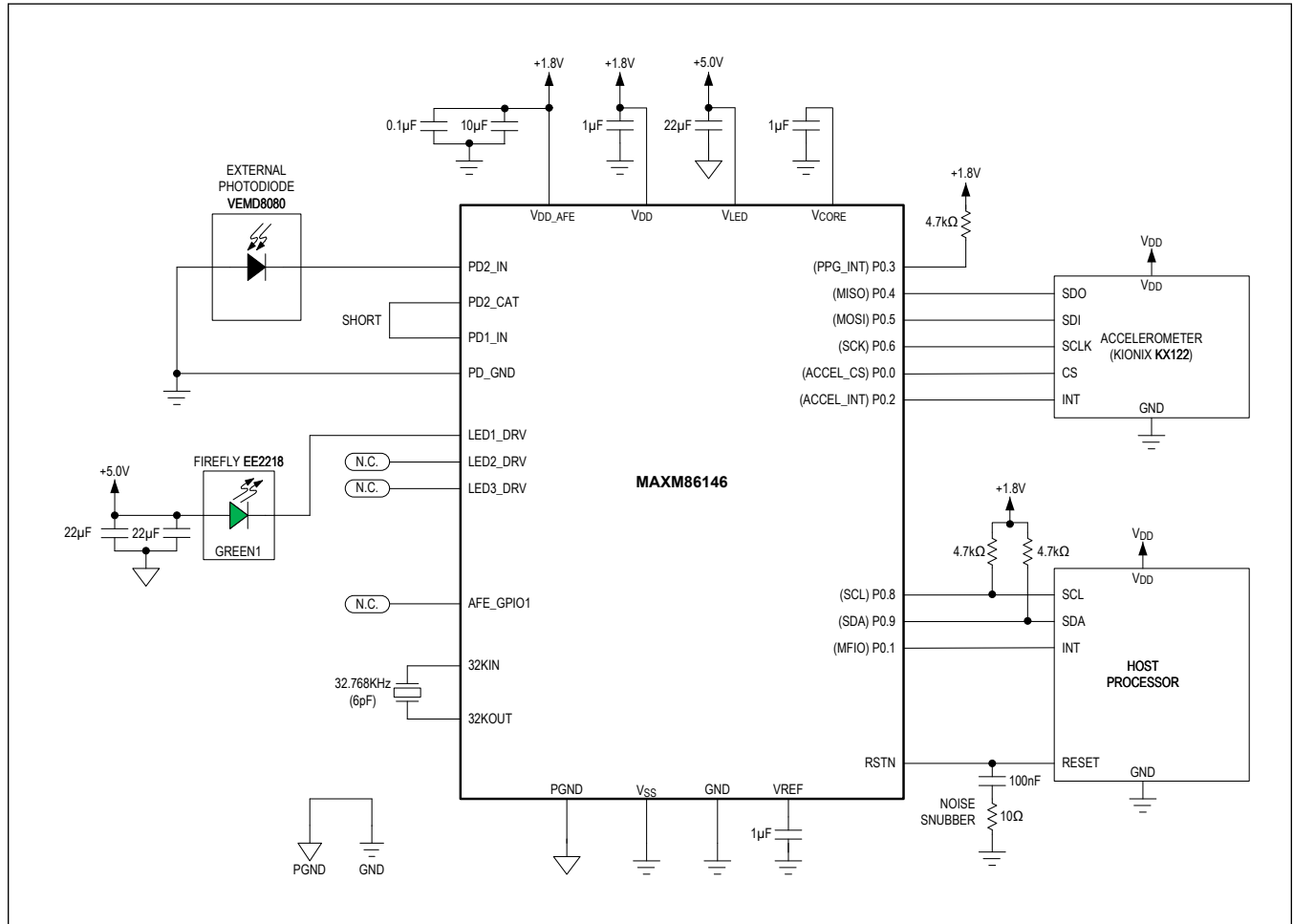

Ordering Information

PART NUMBER	TEMP. RANGE	PIN PACKAGE
MAXM86146CFU+	0°C to +70°C	38-pin OLGA
MAXM86146CFU+T	0°C to +70°C	38-pin OLGA

+Denotes a lead(Pb)-free/RoHS-compliant package.

T = Tape and reel.

Revision History

REVISION NUMBER	REVISION DATE	DESCRIPTION	PAGES CHANGED
0	3/20	Initial release	—

For pricing, delivery, and ordering information, please visit Maxim Integrated's online storefront at <https://www.maximintegrated.com/en/storefront/storefront.html>.

Maxim Integrated cannot assume responsibility for use of any circuitry other than circuitry entirely embodied in a Maxim Integrated product. No circuit patent licenses are implied. Maxim Integrated reserves the right to change the circuitry and specifications without notice at any time. The parametric values (min and max limits) shown in the Electrical Characteristics table are guaranteed. Other parametric values quoted in this data sheet are provided for guidance.

Looking for pricing, stock, or lifecycle information?

Click below to explore more details on WIN SOURCE:

 [View MAXM86146CFU+ on WIN SOURCE](#)

 [Maxim Integrated](#) Information

Optimize Your Supply Chain with WIN SOURCE Solutions

-  Global Sourcing Solution
-  Obsolete Management
-  Cost Control Management
-  Shortage Management
-  Alternative Solution
-  Excess Inventory Management