



**THE DATASHEET OF
VN5T016AH-E**



Single channel high-side driver with analog current sense for 24 V automotive applications

Datasheet – production data



- Overvoltage clamp
- Load current limitation
- Self limiting of fast thermal transients
- Protection against loss of ground and loss of V_{CC}
- Thermal shutdown
- Reverse battery protected with self switch of the PowerMOS
- Electrostatic discharge protection

Features

Max transient supply voltage	V_{CC}	58V
Operating voltage range	V_{CC}	8 to 36V
Typ ON-state resistance	R_{ON}	16 m Ω
Current limitation (typ)	I_{LIM}	60 A
OFF-state supply current	I_S	2 μ A ⁽¹⁾

1. Typical value with all loads connected.

- General
 - Very low stand-by current
 - 3.0 V CMOS compatible input
 - Optimized electromagnetic emission
 - Very low electromagnetic susceptibility
 - Compliant with European directive 2002/95/EC
 - Fault reset standby pin (FR_Stby)
- Diagnostic functions
 - Proportional load current sense
 - Current sense precision for wide range currents
 - Off-state open load detection
 - Output short to V_{CC} detection
 - Overload and short to ground latch-off
 - Thermal shutdown latch-off
 - Very low current sense leakage
- Protections
 - Undervoltage shutdown

Applications

- All types of resistive, inductive and capacitive loads

Description

The VN5T016AH-E is a device made using STMicroelectronics® VIPower® technology, intended for driving resistive or inductive loads with one side connected to ground. Active V_{CC} pin voltage clamp protects the device against low energy spikes. This device integrates an analog current sense which delivers a current proportional to the load current. Fault conditions such as overload, overtemperature or short to V_{CC} are reported via the current sense pin.

Output current limitation protects the device in overload condition. The device latches off in case of overload or thermal shutdown.

The device is reset by a low level pass on the fault reset standby pin.

A permanent low level on the inputs and fault reset standby pin disables all outputs and sets the device in standby mode.

Contents

1	Block diagram and pin description	5
2	Electrical specifications	7
2.1	Absolute maximum ratings	7
2.2	Thermal data	8
2.3	Electrical characteristics	9
2.4	Electrical characteristics curves	19
3	Application information	21
3.1	Load dump protection	21
3.2	MCU I/Os protection	21
3.3	Maximum demagnetization energy ($V_{CC} = 24\text{ V}$)	22
4	Package and PCB thermal data	23
4.1	HPAK thermal data	23
5	Package information	26
5.1	HPAK mechanical data	26
5.2	Packing information	28
6	Order codes	29
7	Revision history	30

List of tables

Table 1.	Pin function	5
Table 2.	Suggested connections for unused and not connected pins	6
Table 3.	Absolute maximum ratings	7
Table 4.	Thermal data	8
Table 5.	Power section	9
Table 6.	Switching ($V_{CC} = 24\text{ V}$; $T_j = 25\text{ °C}$)	9
Table 7.	Logic inputs	10
Table 8.	Protections and diagnostics	11
Table 9.	Current sense ($8\text{ V} < V_{CC} < 36\text{ V}$)	11
Table 10.	Open-load detection ($FR_Stby = 5\text{ V}$)	13
Table 11.	Truth table	17
Table 12.	Electrical transient requirements (part 1)	18
Table 13.	Electrical transient requirements (part 2)	18
Table 14.	Electrical transient requirements (part 3)	18
Table 15.	Thermal parameters	25
Table 16.	HPAK mechanical data	27
Table 17.	Device summary	29
Table 18.	Document revision history	30

List of figures

Figure 1.	Block diagram	5
Figure 2.	Configuration diagram (top view)	6
Figure 3.	Current and voltage conventions	7
Figure 4.	T_{reset} definition	10
Figure 5.	T_{stby} definition	11
Figure 6.	Output stuck to V_{CC} detection delay time at FR_{STBY} activation	14
Figure 7.	Current sense delay characteristics	14
Figure 8.	Open-load off-state delay timing	14
Figure 9.	Switching characteristics	15
Figure 10.	Delay response time between rising edge of output current and rising edge of current sense	15
Figure 11.	Output voltage drop limitation	16
Figure 12.	Device behavior in overload condition	16
Figure 13.	Off-state output current	19
Figure 14.	High level input current	19
Figure 15.	Input clamp voltage	19
Figure 16.	Input low level voltage	19
Figure 17.	Input high level voltage	19
Figure 18.	Input hysteresis voltage	19
Figure 19.	On-state resistance vs T_{case}	20
Figure 20.	On-state resistance vs V_{CC}	20
Figure 21.	I_{LIMH} vs T_{case}	20
Figure 22.	Turn-on voltage slope	20
Figure 23.	Turn-off voltage slope	20
Figure 24.	Application schematic	21
Figure 25.	Maximum turn-off current versus inductance	22
Figure 26.	HPAK PC board	23
Figure 27.	$R_{\text{thj-amb}}$ vs PCB copper area in open box free air condition (one channel ON)	23
Figure 28.	HPAK thermal impedance junction ambient single pulse (one channel ON)	24
Figure 29.	Thermal fitting model of a double channel HSD in HPAK	24
Figure 30.	HPAK package dimensions	26
Figure 31.	HPAK tube shipment (no suffix)	28
Figure 32.	HPAK tape and reel (suffix "TR")	28

1 Block diagram and pin description

Figure 1. Block diagram

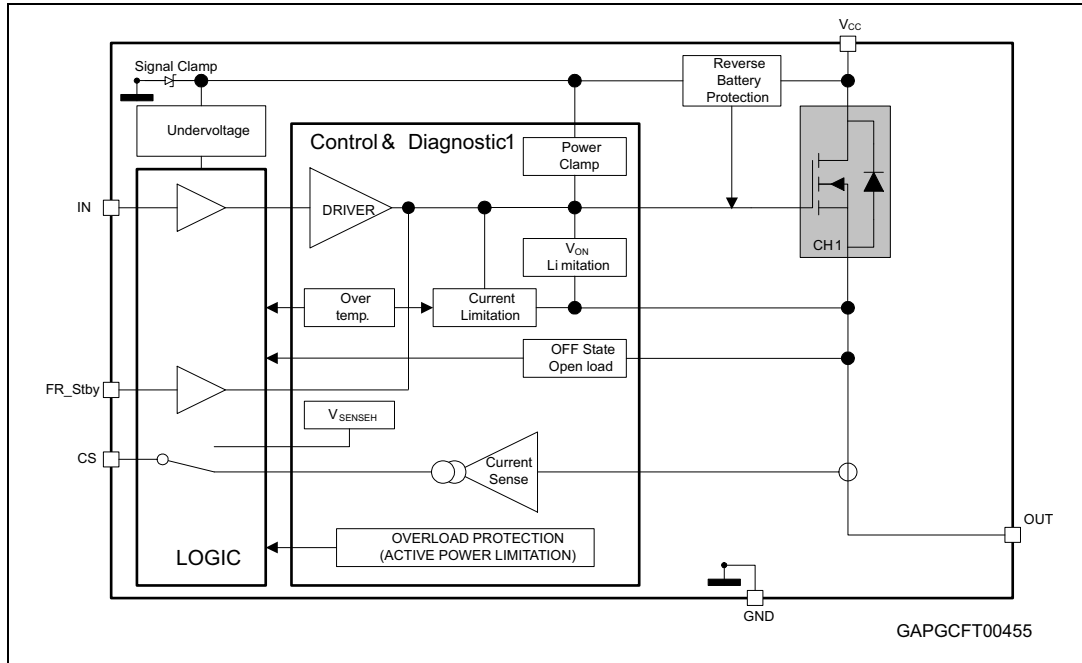

Table 1. Pin function

Name	Function
V _{CC}	Battery connection
OUT	Power output
GND	Ground connection
IN	Voltage controlled input pin with hysteresis, CMOS compatible. It controls output switch state
CS	Analog current sense pin, it delivers a current proportional to the load current
FR_Stby	In case of latch-off for overtemperature/overcurrent condition, a low pulse on the FR_Stby pin is needed to reset the channel. The device enters in standby mode if all inputs and the FR_Stby pin are low.

Figure 2. Configuration diagram (top view)

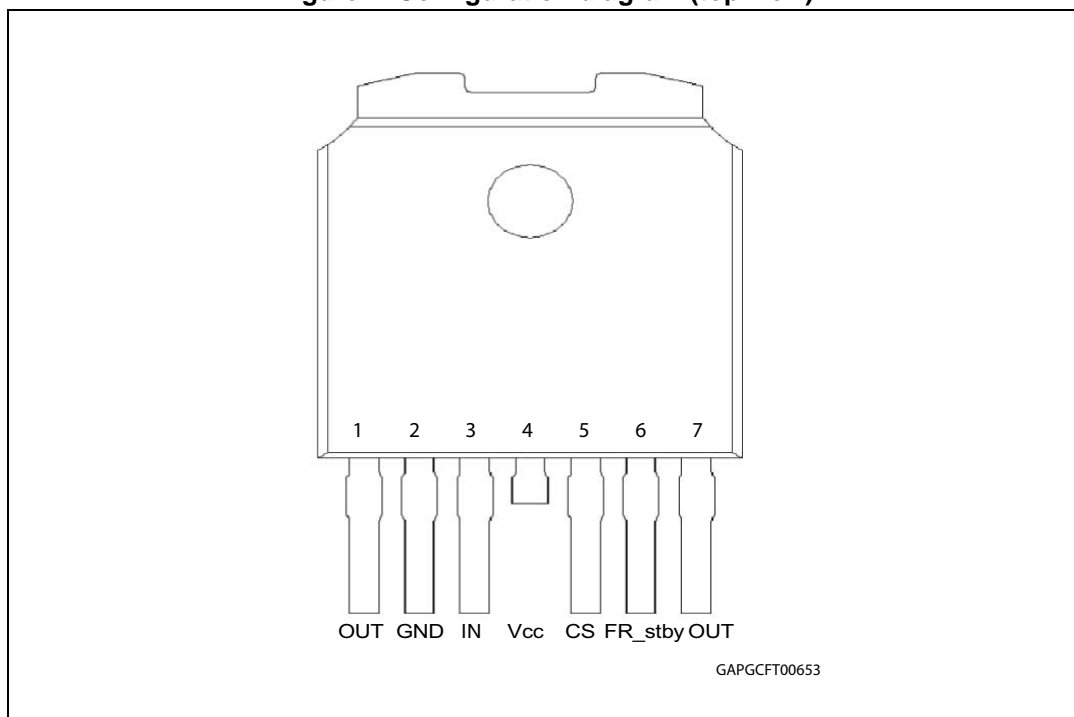

Table 2. Suggested connections for unused and not connected pins

Connection / pin	Current Sense	N.C.	Output	Input	FR_Stby
Floating	Not allowed	X ⁽¹⁾	X	X	X
To ground	Through 10 k Ω resistor	X	Not allowed	Through 10 k Ω resistor	Through 10 k Ω resistor

1. X: do not care.

2 Electrical specifications

Figure 3. Current and voltage conventions

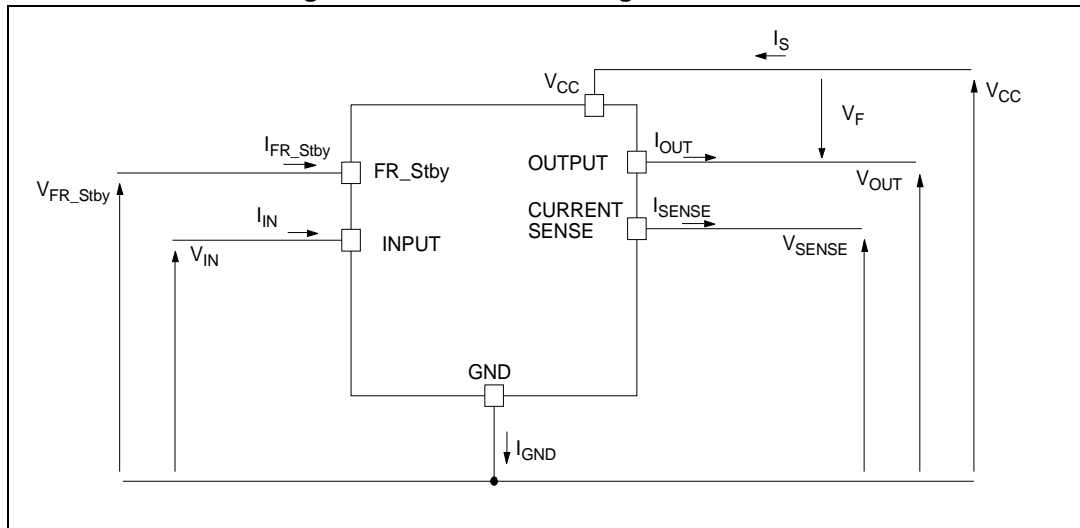

2.1 Absolute maximum ratings

Stressing the device above the ratings listed in [Table 3](#) may cause permanent damage to the device. These are stress ratings only and operation of the device at these or any other conditions above those indicated in the Operating sections of this specification is not implied. Exposure to the conditions reported in this section for extended periods may affect device reliability.

Table 3. Absolute maximum ratings

Symbol	Parameter	Value	Unit
V_{CC}	DC supply voltage	58	V
$-V_{CC}$	Reverse DC supply voltage	-32	V
I_{OUT}	DC output current	Internally limited	A
$-I_{OUT}$	Reverse DC output current	30	A
I_{IN}	DC input current	-1 to 10	mA
I_{FR_Stby}	Fault reset standby DC input current	-1 to 1.5	mA
V_{CSENSE}	Current sense maximum voltage	$V_{CC} - 58$ to $+V_{CC}$	V
E_{MAX}	Maximum switching energy ($L = 10$ mH; $V_{bat} = 32$ V; $T_{jstart} = 150^\circ\text{C}$; $I_{OUT} = 5.9$ A)	390	mJ
L_{SMAX}	Maximum stray inductance in short circuit condition ($V_{bat} = 32$ V; $R_L = 300$ m Ω ; $T_{jstart} = 150^\circ\text{C}$; $I_{OUT} = I_{limH_max}$)	40	μH

Table 3. Absolute maximum ratings (continued)

Symbol	Parameter	Value	Unit
V _{ESD}	Electrostatic discharge (Human Body Model: R = 1.5 kΩ; C = 100 pF)		
	– INPUT	4000	V
	– CURRENT SENSE	2000	V
	– FAULT RESET STANDBY PIN	4000	V
	– OUTPUT	5000	V
	– V _{CC}	5000	V
V _{ESD}	Charge device model (CDM-AEC-Q100-011)	750	V
T _j	Junction operating temperature	-40 to 150	°C
T _{stg}	Storage temperature	-55 to 150	°C

2.2 Thermal data

Table 4. Thermal data

Symbol	Parameter	Value	Unit
R _{thj-case}	Thermal resistance junction-case (max.)	1.5	°C/W
R _{thj-amb}	Thermal resistance junction-ambient (max.)	See Figure 27	°C/W

2.3 Electrical characteristics

$8\text{ V} < V_{CC} < 36\text{ V}$; $-40^\circ\text{C} < T_j < 150^\circ\text{C}$, unless otherwise specified.

Table 5. Power section

Symbol	Parameter	Test conditions	Min.	Typ.	Max.	Unit
V_{CC}	Operating supply voltage		8	24	36	V
V_{USD}	Undervoltage shutdown			3.5	5	V
$V_{USDhyst}$	Undervoltage shutdown hysteresis			0.5		V
R_{ON}	On-state resistance	$I_{OUT} = 5\text{ A}$; $T_j = 25^\circ\text{C}$; $8\text{ V} < V_{CC} < 36\text{ V}$		16		m Ω
		$I_{OUT} = 5\text{ A}$; $T_j = 150^\circ\text{C}$; $8\text{ V} < V_{CC} < 36\text{ V}$			32	
$R_{ON REV}$	Reverse battery ON-state resistance	$V_{CC} = -24\text{ V}$; $I_{OUT} = -5\text{ A}$; $T_j = 25^\circ\text{C}$			16	m Ω
V_{clamp}	Clamp voltage	$I_S = 20\text{ mA}$	58	64	70	V
I_S	Supply current	Off-state; $V_{CC} = 24\text{ V}$; $T_j = 25^\circ\text{C}$; $V_{IN} = V_{OUT} = V_{SENSE} = 0\text{ V}$		2 ⁽¹⁾	5	μA
		On-state; $V_{CC} = 24\text{ V}$; $V_{IN} = 5\text{ V}$; $I_{OUT} = 0\text{ A}$		2.5	5	mA
$I_{L(off1)}$	Off-state output current	$V_{IN} = V_{OUT} = 0\text{ V}$; $V_{CC} = 24\text{ V}$; $T_j = 25^\circ\text{C}$	0	0.01	3	μA
		$V_{IN} = V_{OUT} = 0\text{ V}$; $V_{CC} = 24\text{ V}$; $T_j = 125^\circ\text{C}$	0		5	

1. PowerMOS leakage included.

Table 6. Switching ($V_{CC} = 24\text{ V}$; $T_j = 25^\circ\text{C}$)

Symbol	Parameter	Test conditions	Min.	Typ.	Max.	Unit
$t_{d(on)}$	Turn-on delay time	$R_L = 4.8\ \Omega$	—	55	—	μs
$t_{d(off)}$	Turn-off delay time	$R_L = 4.8\ \Omega$	—	53	—	μs
$dV_{OUT}/dt_{(on)}$	Turn-on voltage slope	$R_L = 4.8\ \Omega$		0.59		V/ μs
$dV_{OUT}/dt_{(off)}$	Turn-off voltage slope	$R_L = 4.8\ \Omega$		0.54		V/ μs
W_{ON}	Switching energy losses during t_{won}	$R_L = 4.8\ \Omega$	—	2.35	—	mJ
W_{OFF}	Switching energy losses during t_{woff}	$R_L = 4.8\ \Omega$	—	1.05	—	mJ

Table 7. Logic inputs

Symbol	Parameter	Test conditions	Min.	Typ.	Max.	Unit
V_{IL}	Input low level voltage				0.9	V
I_{IL}	Low level input current	$V_{IN} = 0.9\text{ V}$	1			μA
V_{IH}	Input high level voltage		2.1			V
I_{IH}	High level input current	$V_{IN} = 2.1\text{ V}$			10	μA
$V_{I(hyst)}$	Input hysteresis voltage		0.25			V
V_{ICL}	Input clamp voltage	$I_{IN} = 1\text{ mA}$	5.5		7	V
		$I_{IN} = -1\text{ mA}$		-0.7		
$V_{FR_Stby_L}$	Fault reset standby low level voltage				0.9	V
$I_{FR_Stby_L}$	Low level fault reset standby current	$V_{FR_Stby} = 0.9\text{ V}$	1			μA
$V_{FR_Stby_H}$	Fault reset standby high level voltage		2.1			V
$I_{FR_Stby_H}$	High level fault reset standby current	$V_{FR_Stby} = 2.1\text{ V}$			10	μA
$V_{FR_Stby(hyst)}$	Fault reset standby hysteresis voltage		0.25			V
$V_{FR_Stby_CL}$	Fault reset standby clamp voltage	$I_{FR_Stby} = 15\text{ mA (10 ms)}$	11		15	V
		$I_{FR_Stby} = -1\text{ mA}$		-0.7		
t_{reset}	Overload latch-off reset time	See Figure 4	2		24	μs
t_{stby}	Standby delay	See Figure 5	120		1200	μs

Figure 4. T_{reset} definition

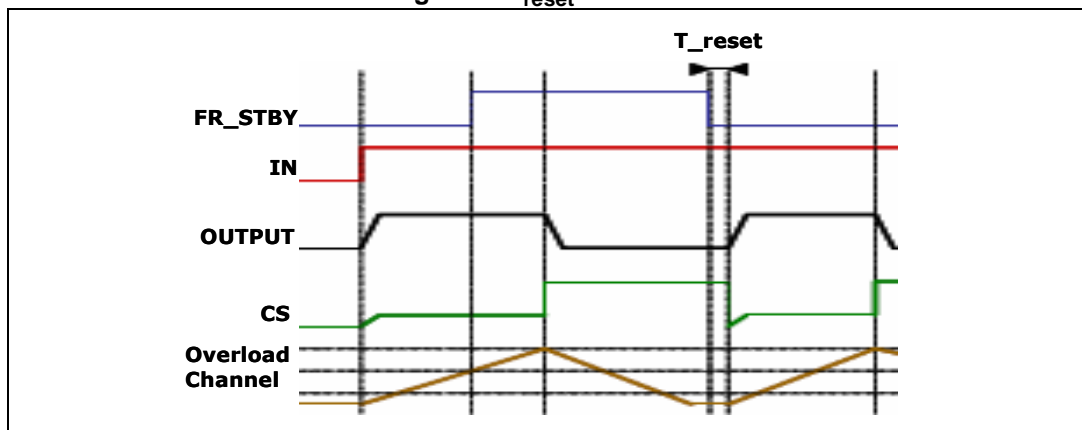

Figure 5. T_{stby} definition

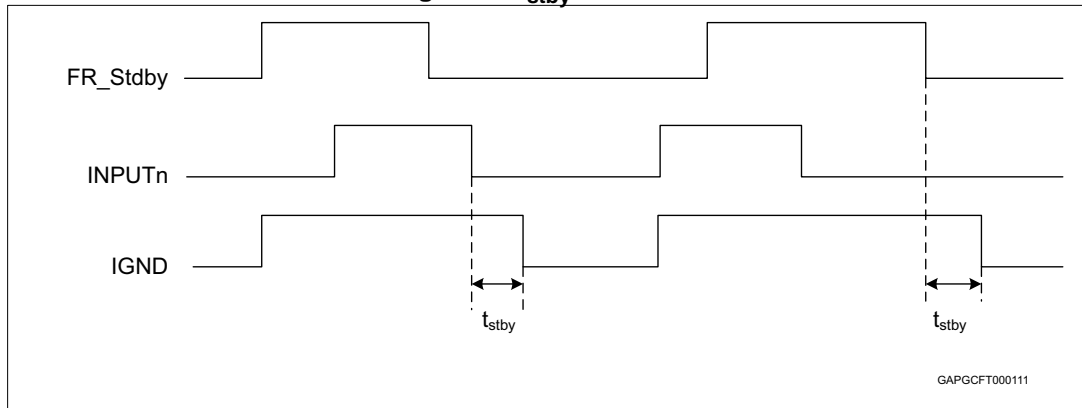

Table 8. Protections and diagnostics

Symbol	Parameter	Test conditions	Min.	Typ.	Max.	Unit
I_{limH}	DC short circuit current	$V_{CC} = 24\text{ V}$	43	60	86	A
		$5\text{ V} < V_{CC} < 36\text{ V}$			86	A
I_{limL}	Short circuit current during thermal cycling	$V_{CC} = 24\text{ V}; T_R < T_j < T_{TSD}$		15		A
T_{TSD}	Shutdown temperature		150	175	200	$^{\circ}\text{C}$
T_R	Reset temperature		$T_{RS}+1$	$T_{RS}+5$		$^{\circ}\text{C}$
T_{RS}	Thermal reset of status		135			$^{\circ}\text{C}$
T_{HYST}	Thermal hysteresis ($T_{TSD}-T_R$)			7		$^{\circ}\text{C}$
V_{DEMAG}	Turn-off output voltage clamp	$I_{OUT} = 5\text{ A}; V_{IN} = 0\text{ V}; L = 6\text{ mH}$	$V_{CC}-58$	$V_{CC}-64$	$V_{CC}-70$	V
V_{ON}	Output voltage drop limitation	$I_{OUT} = 500\text{ mA}; T_j = -40^{\circ}\text{C to } 150^{\circ}\text{C}$		25		mV

Table 9. Current sense ($8\text{ V} < V_{CC} < 36\text{ V}$)

Symbol	Parameter	Test conditions	Min.	Typ.	Max.	Unit
$dK_{LED}/K_{LED(TOT)}^{(1)}$	Current sense ratio drift	$I_{OUT} = 12\text{ mA to } 100\text{ mA}; I_{CAL} = 50\text{ mA}; V_{SENSE} = 0.5\text{ V}; T_j = -40^{\circ}\text{C to } 150^{\circ}\text{C}$	-50		50	%
K_0	I_{OUT}/I_{SENSE}	$I_{OUT} = 100\text{ mA}; V_{SENSE} = 0.5\text{ V}; T_j = -40^{\circ}\text{C to } 150^{\circ}\text{C}$	1333	5600	11884	
$dK_0/K_0^{(1)}$	Current sense ratio drift	$I_{OUT} = 100\text{ mA}; V_{SENSE} = 0.5\text{ V}; T_j = -40^{\circ}\text{C to } 150^{\circ}\text{C}$	-21		32	%
K_1	I_{OUT}/I_{SENSE}	$I_{OUT} = 0.6\text{ A}; V_{SENSE} = 1\text{ V}; T_j = -40^{\circ}\text{C to } 150^{\circ}\text{C}; T_j = 25^{\circ}\text{C to } 150^{\circ}\text{C}$	2418 3139	5300	9264 7981	
$dK_1/K_1^{(1)}$	Current sense ratio drift	$I_{OUT} = 0.6\text{ A}; V_{SENSE} = 1\text{ V}; T_j = -40^{\circ}\text{C to } 150^{\circ}\text{C}$	-21		23	%

Table 9. Current sense (8 V < V_{CC} < 36 V) (continued)

Symbol	Parameter	Test conditions	Min.	Typ.	Max.	Unit
K ₂	I _{OUT} /I _{SENSE}	I _{OUT} = 1.6 A; V _{SENSE} = 1 V; T _j = -40°C to 150°C T _j = 25 °C to 150 °C	2928 3072	4700	7568 6693	
dK ₂ /K ₂ ⁽¹⁾	Current sense ratio drift	I _{OUT} = 1.6 A; V _{SENSE} = 1 V; T _j = -40°C to 150°C	-26		21	%
K ₃	I _{OUT} /I _{SENSE}	I _{OUT} = 2.4 A; V _{SENSE} = 2 V; T _j = -40°C to 150°C T _j = 25°C to 150°C	2912 3007	4400	7048 6039	
dK ₃ /K ₃ ⁽¹⁾	Current sense ratio drift	I _{OUT} = 2.4 A; V _{SENSE} = 2 V; T _j = -40°C to 150°C	-19		24	%
K ₄	I _{OUT} /I _{SENSE}	I _{OUT} = 3 A; V _{SENSE} = 4 V; T _j = -40°C to 150°C T _j = 25 °C to 150 °C	2843 3142	4300	6686 5634	
dK ₄ /K ₄ ⁽¹⁾	Current sense ratio drift	I _{OUT} = 3 A; V _{SENSE} = 4 V; T _j = -40°C to 150°C	-16		22	%
K ₅	I _{OUT} /I _{SENSE}	I _{OUT} = 4.2 A; V _{SENSE} = 4 V; T _j = -40°C to 150°C T _j = 25°C to 150°C	3034 3402	4250	5977 5276	
dK ₅ /K ₅ ⁽¹⁾	Current sense ratio drift	I _{OUT} = 4.2 A; V _{SENSE} = 4 V; T _j = -40°C to 150°C	-13		16	%
K ₆	I _{OUT} /I _{SENSE}	I _{OUT} = 20 A; V _{SENSE} = 4 V; T _j = -40°C to 150°C	3942	4240	4748	
dK ₆ /K ₆ ⁽¹⁾	Current sense ratio drift	I _{OUT} = 20 A; V _{SENSE} = 4 V; T _j = -40°C to 150°C	-5		5	%
dK/K _{bulb1(TOT)} ⁽¹⁾	Current sense ratio drift	I _{OUT} = 1.6 A to 4.2 A; I _{OUTCAL} = 3 A; V _{SENSE} = 4 V; T _j = -40°C to 150°C	-17		40	%
dK/K _{bulb2(TOT)} ⁽¹⁾	Current sense ratio drift	I _{OUT} = 0.6 A to 2.4 A; I _{OUTCAL} = 1.2 A; V _{SENSE} = 2 V; T _j = -40°C to 150°C	-31		33	%
I _{SENSE0}	Analog sense leakage current	I _{OUT} = 0 A; V _{SENSE} = 0 V; V _{IN} = 0 V; T _j = -40°C to 150°C	0		1	μA
		I _{OUT} = 0 A; V _{SENSE} = 0 V; V _{IN} = 5 V; T _j = -40°C to 150°C	0		2	
V _{SENSE}	Max analog sense output voltage	I _{OUT} = 20 A; R _{SENSE} = 3.9 kΩ	5			V
V _{SENSEH}	Analog sense output voltage in fault condition ⁽²⁾	V _{CC} = 24 V; R _{SENSE} = 3.9 kΩ		8		V
I _{SENSEH}	Analog sense output current in fault condition ⁽²⁾	V _{CC} = 24 V; V _{SENSE} = 5 V		9	12	mA

Table 9. Current sense ($8\text{ V} < V_{CC} < 36\text{ V}$) (continued)

Symbol	Parameter	Test conditions	Min.	Typ.	Max.	Unit
t_{DSENSE2H}	Delay response time from rising edge of INPUT pin	$V_{\text{SENSE}} < 4\text{ V}$; $0.5\text{ A} < I_{\text{OUT}} < 20\text{ A}$; $I_{\text{SENSE}} = 90\%$ of $I_{\text{SENSE max}}$ (see Figure 7)		300	600	μs
$\Delta t_{\text{DSENSE2H}}$	Delay response time between rising edge of output current and rising edge of current sense	$V_{\text{SENSE}} < 4\text{ V}$; $I_{\text{SENSE}} = 90\%$ of I_{SENSEMAX} ; $I_{\text{OUT}} = 90\%$ of I_{OUTMAX} ; $I_{\text{OUTMAX}} = 5\text{ A}$ (see Figure 10)			450	μs
t_{DSENSE2L}	Delay response time from falling edge of INPUT pin	$V_{\text{SENSE}} < 4\text{ V}$; $0.5\text{ A} < I_{\text{OUT}} < 20\text{ A}$; $I_{\text{SENSE}} = 10\%$ of $I_{\text{SENSE max}}$ (see Figure 7)		3	20	μs

- Parameter guaranteed by design; it is not tested.
- Fault condition includes: power limitation, overtemperature and open load in OFF-state condition.

Table 10. Open-load detection ($\text{FR_Stby} = 5\text{ V}$)

Symbol	Parameter	Test conditions	Min.	Typ.	Max.	Unit
V_{OL}	Openload off-state voltage detection threshold	$V_{\text{IN}} = 0\text{ V}$; $8\text{ V} < V_{CC} < 36\text{ V}$	2		4	V
t_{DSTKON}	Output short circuit to V_{CC} detection delay at turn-off	See Figure 8	180		1800	μs
$I_{\text{L(off2)}}$	Off-state output current at $V_{\text{OUT}} = 4\text{ V}$	$V_{\text{IN}} = 0\text{ V}$; $V_{\text{SENSE}} = 0\text{ V}$; V_{OUT} rising from 0 V to 4 V	-120		0	μA
$t_{\text{d_vol}}$	Delay response from output rising edge to V_{SENSE} rising edge in openload	$V_{\text{OUT}} = 4\text{ V}$; $V_{\text{IN}} = 0\text{ V}$; $V_{\text{SENSE}} = 90\%$ of V_{SENSEH} ; $R_{\text{SENSE}} = 3.9\text{ k}\Omega$			20	μs
$t_{\text{DFRSTK_ON}}$	Output short circuit to V_{CC} detection delay at FRSTBY activation	See Figure 8 ; Input _{1,2} = low			50	μs

Figure 6. Output stuck to V_{CC} detection delay time at FR_{STBY} activation

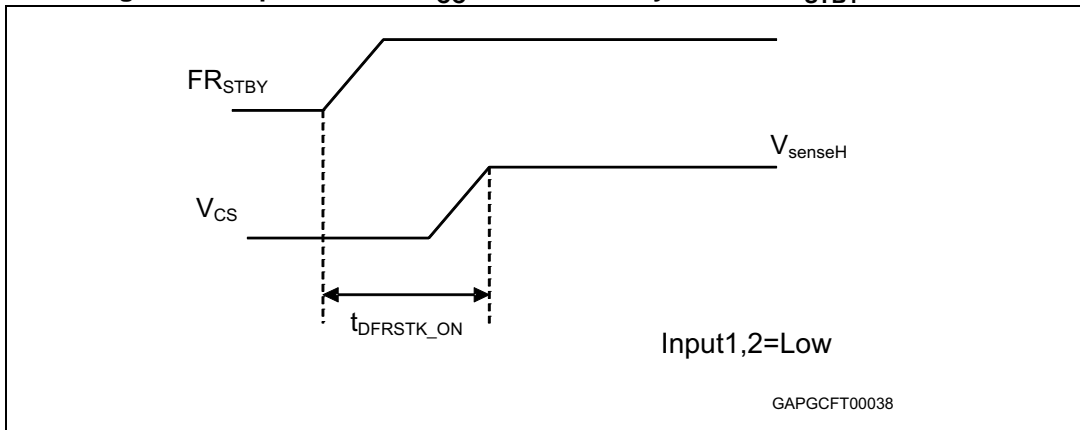

Figure 7. Current sense delay characteristics

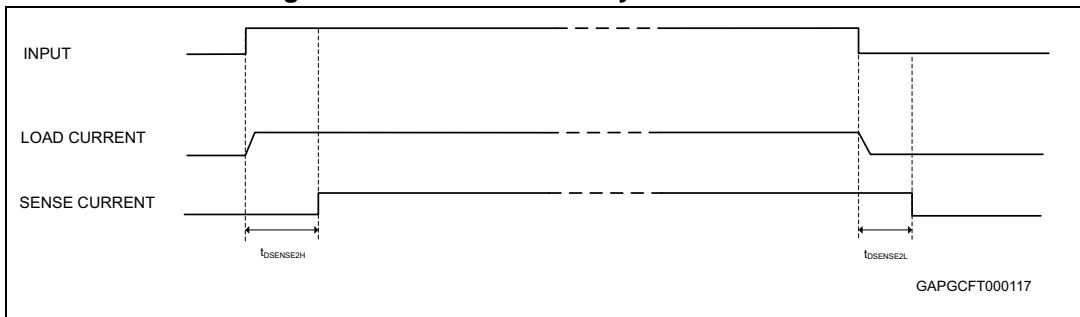
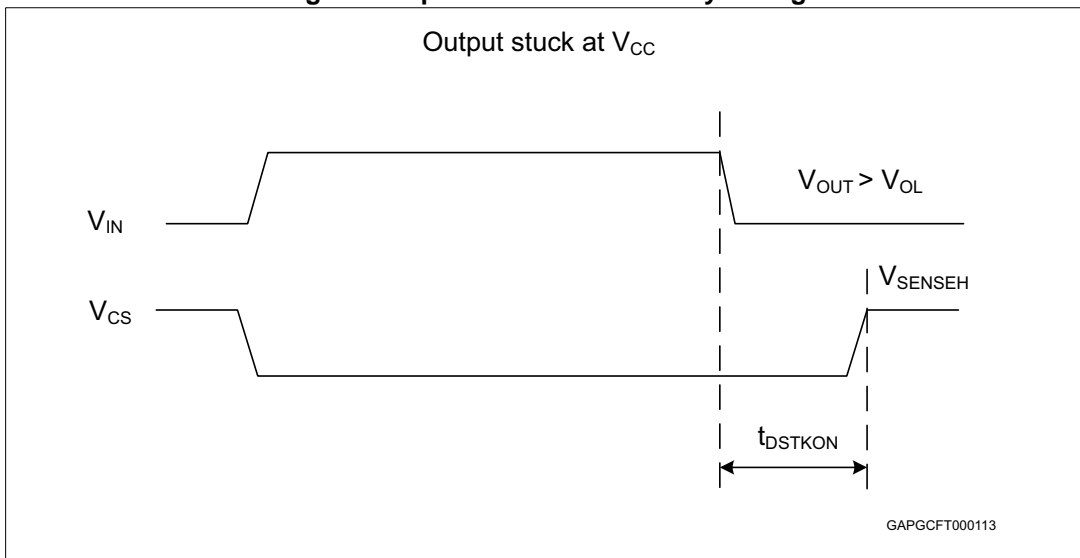

Figure 8. Open-load off-state delay timing



1. With $FR_Stby = 5 V$.

Figure 9. Switching characteristics

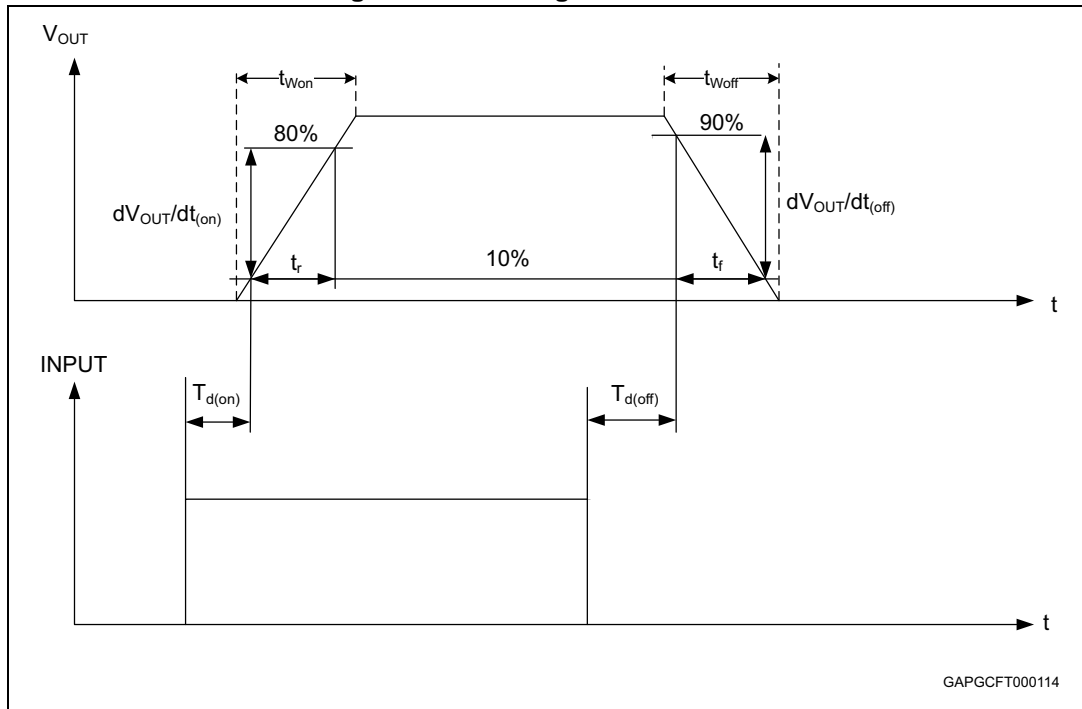

Figure 10. Delay response time between rising edge of output current and rising edge of current sense

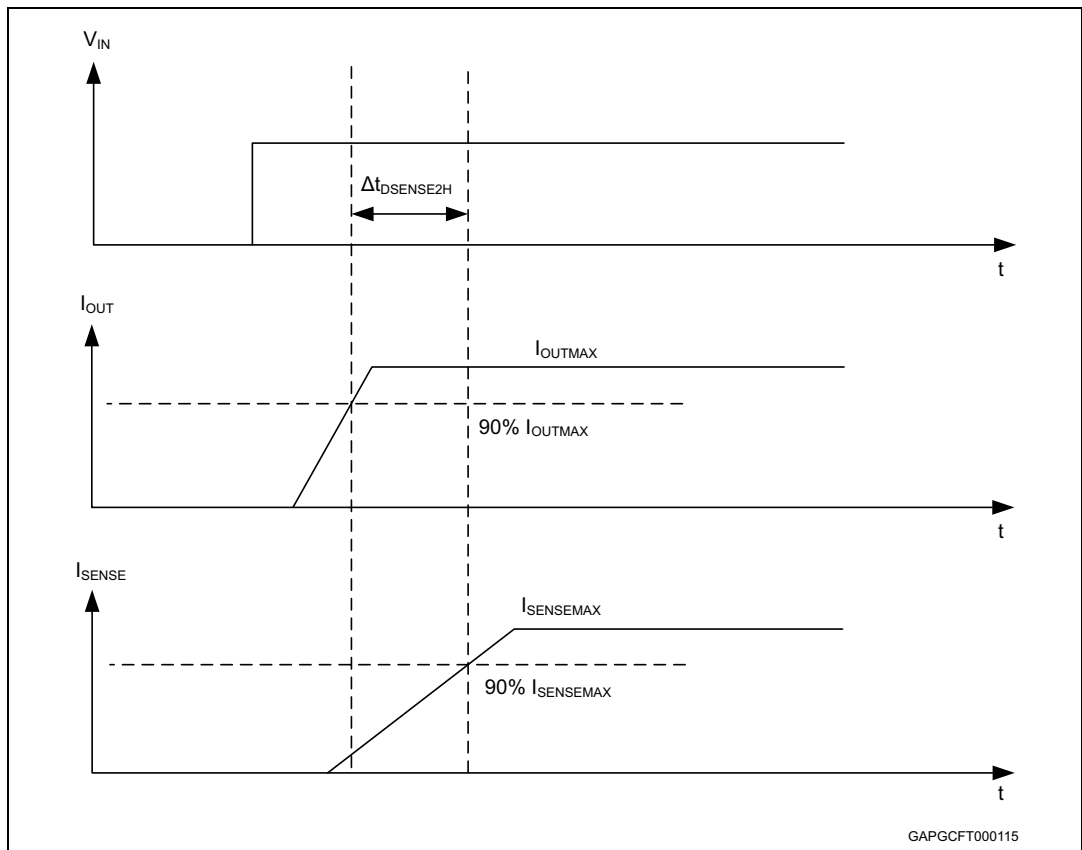

Figure 11. Output voltage drop limitation

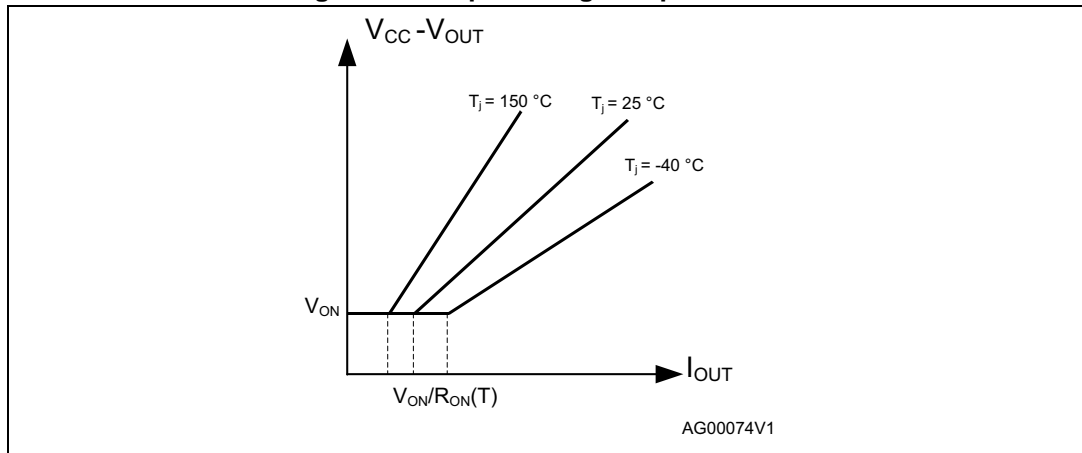

Figure 12. Device behavior in overload condition

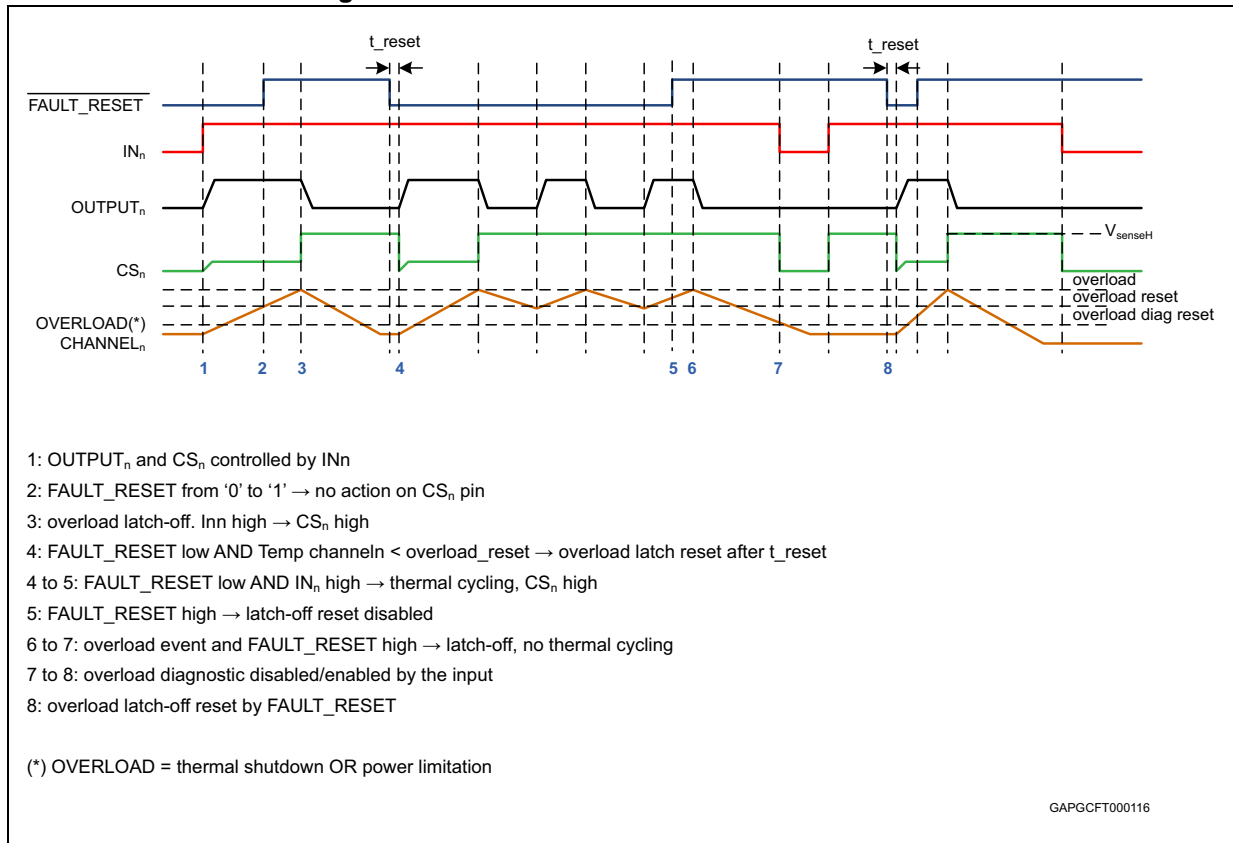

Table 11. Truth table

Conditions	Fault reset standby	Input	Output	Sense
Standby	L	L	X	0
Normal operation	X	L	L	0
	X	H	H	Nominal
Overload	X	L	L	0
	X	H	H	> Nominal
Overtemperature / short to ground	X	L	L	0
	L	H	Cycling	V_{SENSEH}
	H	H	Latched	V_{SENSEH}
Undervoltage	X	X	L	0
Short to V_{BAT}	L	L	H	0
	H	L	H	V_{SENSEH}
	X	H	H	< Nominal
Open load off-state (with pull-up)	L	L	H	0
	H	L	H	V_{SENSEH}
	X	H	H	0
Negative output voltage clamp	X	L	Negative	0

Table 12. Electrical transient requirements (part 1)

ISO 7637-2: 2004(E) Test pulse	Test levels ⁽¹⁾		Number of pulses or test times	Burst cycle/pulse repetition time		Delays and impedance
	III	IV				
1	- 450 V	- 600 V	5000 pulses	0.5 s	5 s	1 ms, 50 Ω
2a	+ 37 V	+ 50 V	5000 pulses	0.2 s	5 s	50 μs, 2 Ω
3a	- 150 V	- 200 V	1h	90 ms	100 ms	0.1 μs, 50 Ω
3b	+ 150 V	+ 200 V	1h	90 ms	100 ms	0.1 μs, 50 Ω
4	- 12 V	- 16 V	1 pulse			100 ms, 0.01 Ω
5b ⁽²⁾	+ 123 V	+ 174 V	1 pulse			350 ms, 1 Ω

1. The above test levels must be considered referred to $V_{CC} = 24.5V$ except for pulse 5b
2. Valid in case of external load dump clamp: 58V maximum referred to ground.

Table 13. Electrical transient requirements (part 2)

ISO 7637-2: 2004(E) Test pulse	Test level results	
	III	IV
1	C	C ⁽¹⁾
2a	C	C
3a	C	C
3b ⁽²⁾	E	E
3b ⁽³⁾	C	C
4	C	C
5b ⁽⁴⁾	C	C

1. With $R_{load} < 24 \Omega$.
2. Without capacitor between V_{CC} and GND.
3. With 10 nF between V_{CC} and GND.
4. External load dump clamp, 58 V maximum, referred to ground.

Table 14. Electrical transient requirements (part 3)

Class	Contents
C	All functions of the device are performed as designed after exposure to disturbance.
E	One or more functions of the device are not performed as designed after exposure to disturbance and cannot be returned to proper operation without replacing the device.

2.4 Electrical characteristics curves

Figure 13. Off-state output current

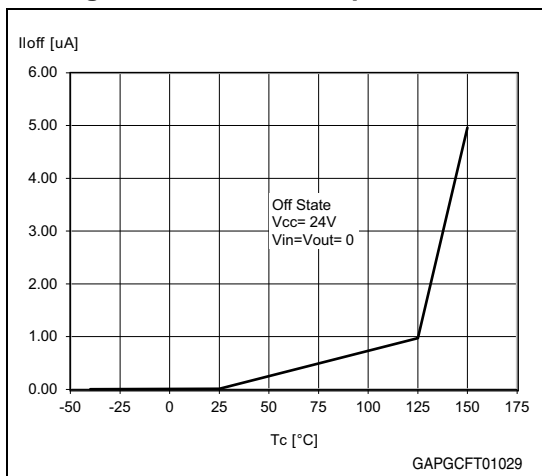

Figure 14. High level input current

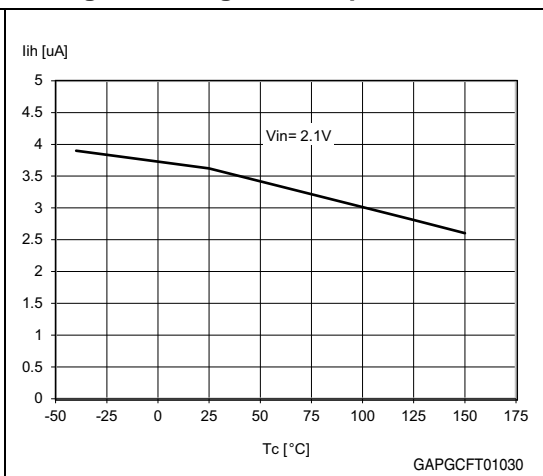

Figure 15. Input clamp voltage

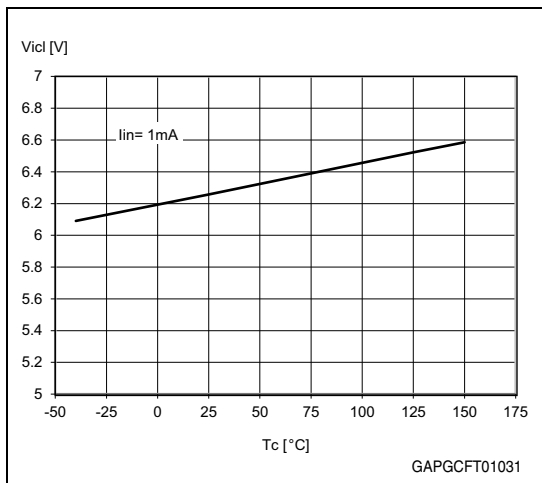

Figure 16. Input low level voltage

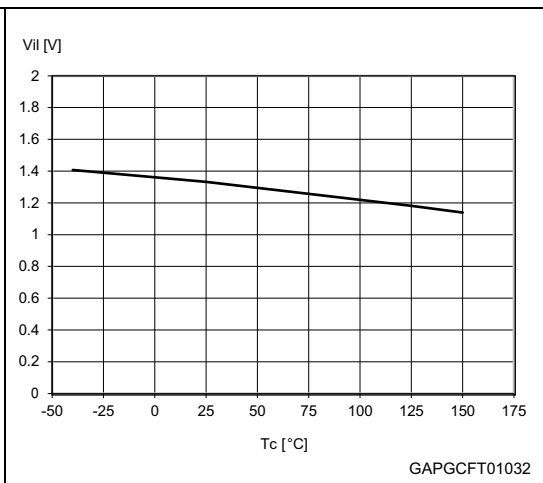

Figure 17. Input high level voltage

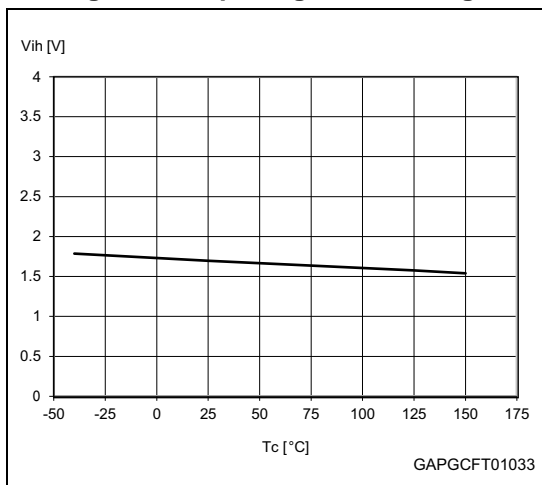

Figure 18. Input hysteresis voltage

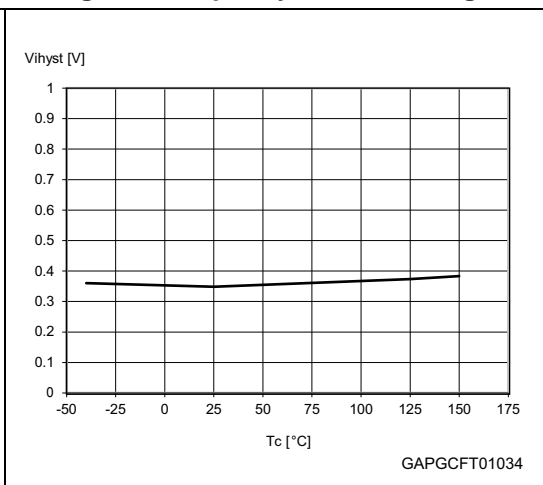

Figure 19. On-state resistance vs T_{case}

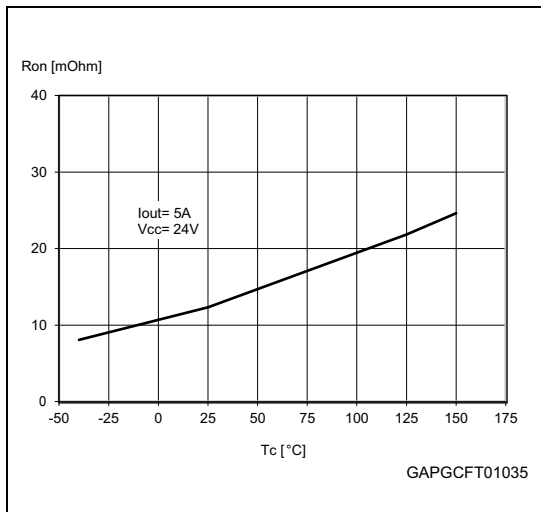

Figure 20. On-state resistance vs V_{CC}

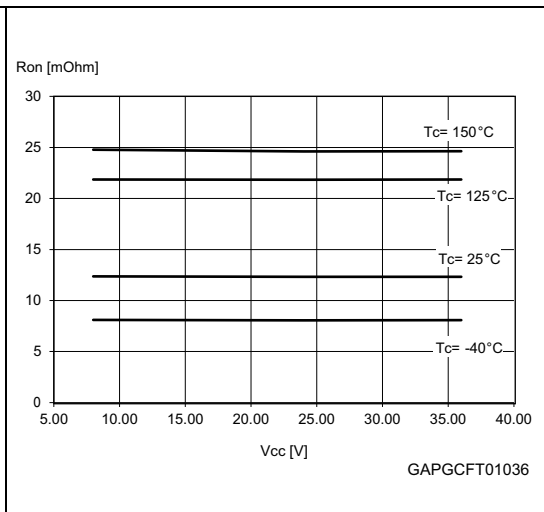

Figure 21. I_{LIMH} vs T_{case}

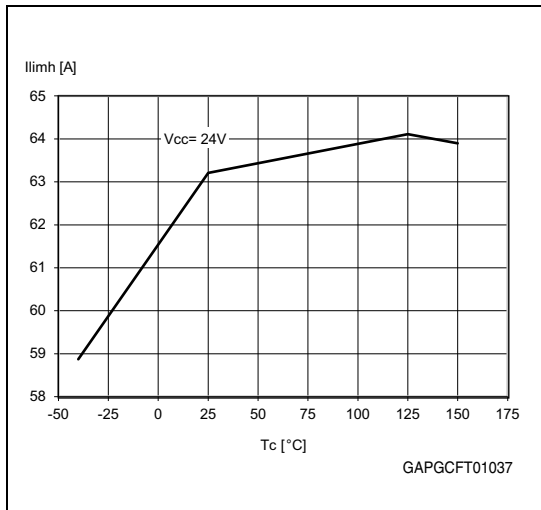

Figure 22. Turn-on voltage slope

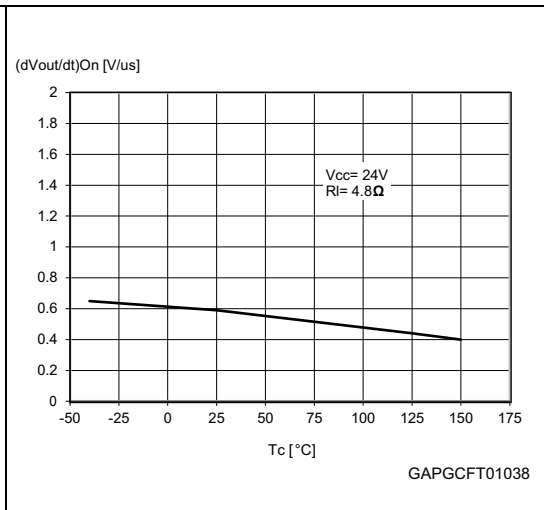
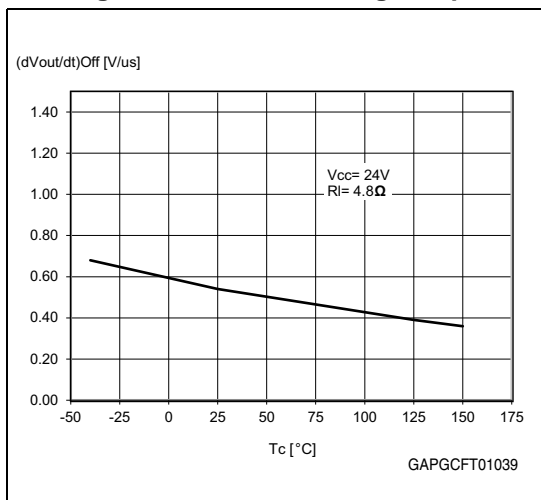
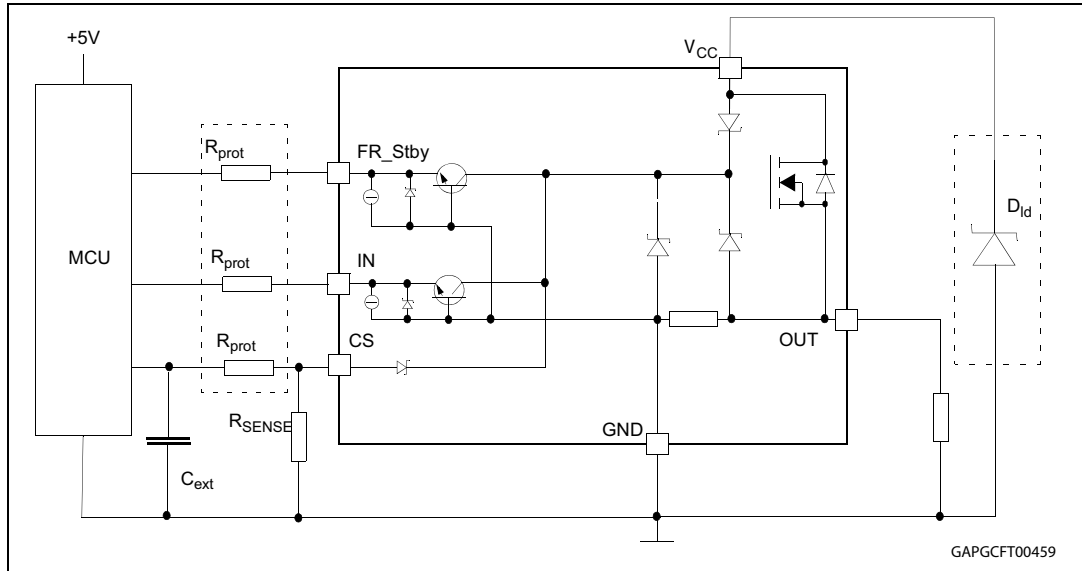

Figure 23. Turn-off voltage slope



3 Application information

Figure 24. Application schematic



3.1 Load dump protection

D_{id} is necessary (voltage transient suppressor) if the load dump peak voltage exceeds the V_{CC} max DC rating. The same applies if the device is subject to transients on the V_{CC} line that are greater than the ones shown in the ISO 7637-2 2004 (E) table.

3.2 MCU I/Os protection

When negative transients are present on the V_{CC} line, the control pins is pulled negative. ST suggests to insert a resistor (R_{prot}) in line to prevent the microcontroller I/O pins from latching-up.

The value of these resistors is a compromise between the leakage current of microcontroller and the current required by the HSD I/Os (input levels compatibility) with the latch-up limit of microcontroller I/Os.

Equation 1

$$-V_{CCpeak} / I_{latchup} \leq R_{prot} \leq (V_{OH\mu C} - V_{IH}) / I_{IHmax}$$

Calculation example:

For $V_{CCpeak} = -600$ V and $I_{latchup} \geq 20$ mA; $V_{OH\mu C} \geq 4.5$ V

30 k $\Omega \leq R_{prot} \leq 190$ k Ω .

Recommended value: $R_{prot} = 56$ k Ω

3.3 Maximum demagnetization energy ($V_{CC} = 24\text{ V}$)

Figure 25. Maximum turn-off current versus inductance

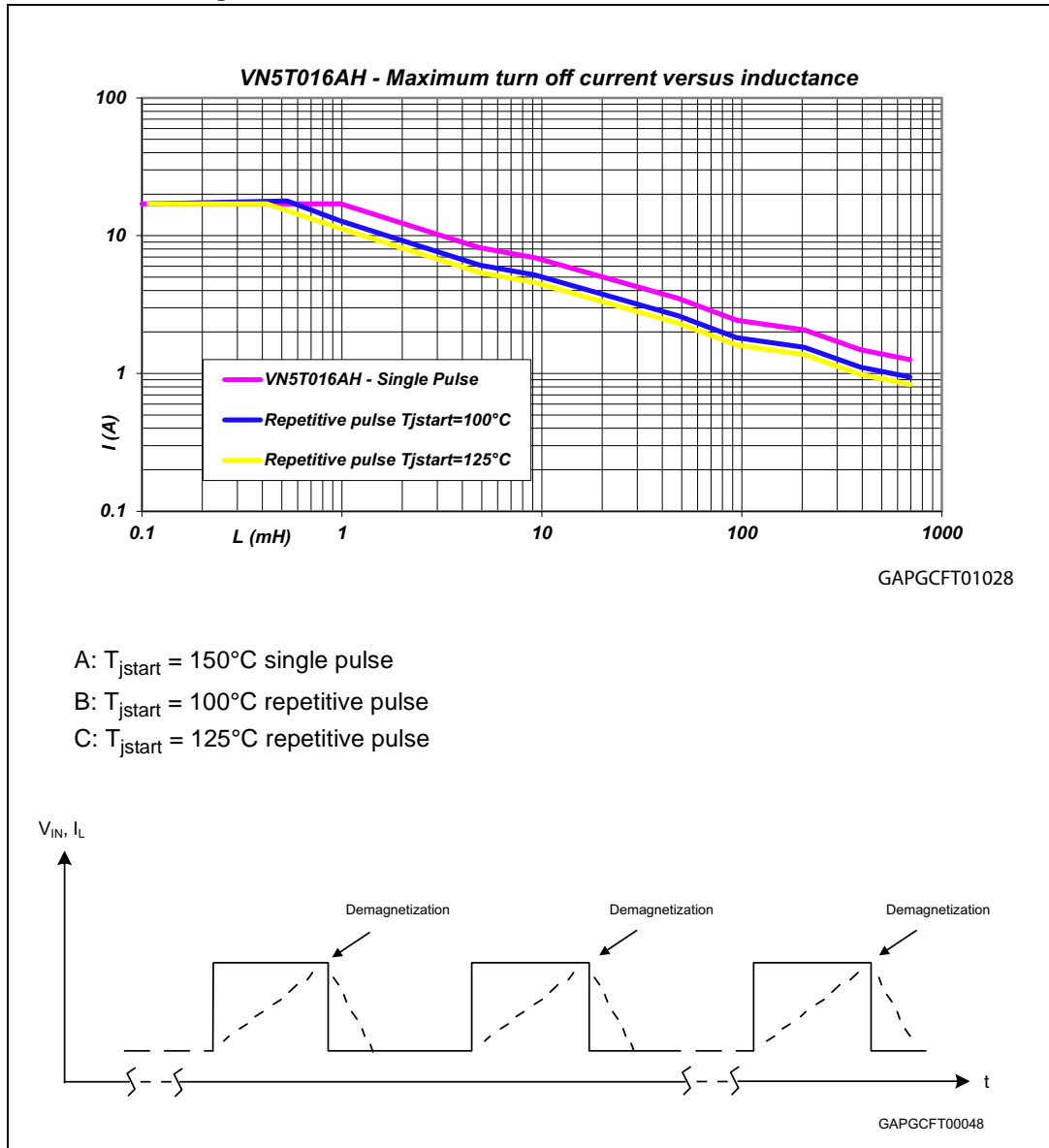

- A: $T_{jstart} = 150^{\circ}\text{C}$ single pulse
- B: $T_{jstart} = 100^{\circ}\text{C}$ repetitive pulse
- C: $T_{jstart} = 125^{\circ}\text{C}$ repetitive pulse

1. Values are generated with $R_L = 0\ \Omega$. In case of repetitive pulses, T_{jstart} (at the beginning of each demagnetization) of every pulse must not exceed the temperature specified above for curves A and B.

4 Package and PCB thermal data

4.1 HPAK thermal data

Figure 26. HPAK PC board

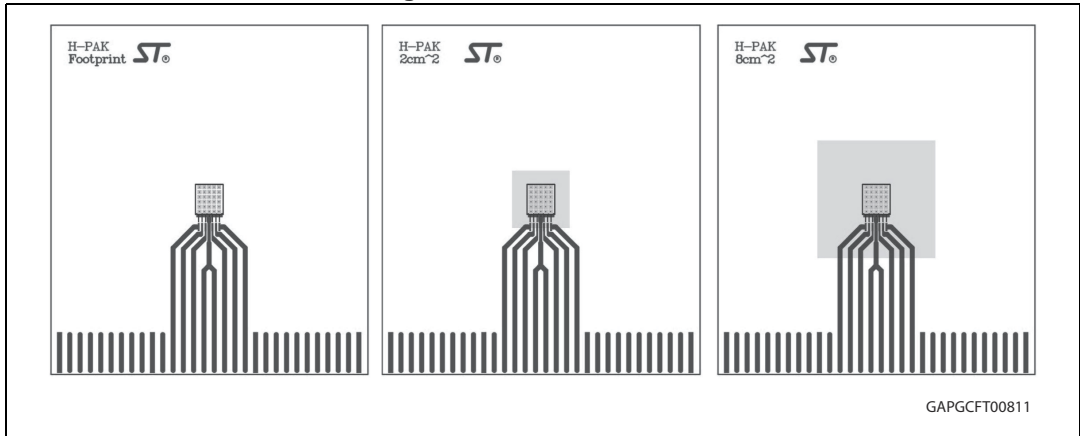

1. Layout condition of R_{th} and Z_{th} measurements (Board finish thickness 1.6 mm +/- 10%; Board double layer; Board dimension 78x86; Board Material FR4; Cu thickness 0.070mm (front and back side); Thermal vias separation 1.2 mm; Thermal via diameter 0.3 mm +/- 0.08 mm; Cu thickness on vias 0.025 mm; Footprint dimension 6.4 mm x 7 mm).

Figure 27. $R_{thj-amb}$ vs PCB copper area in open box free air condition (one channel ON)

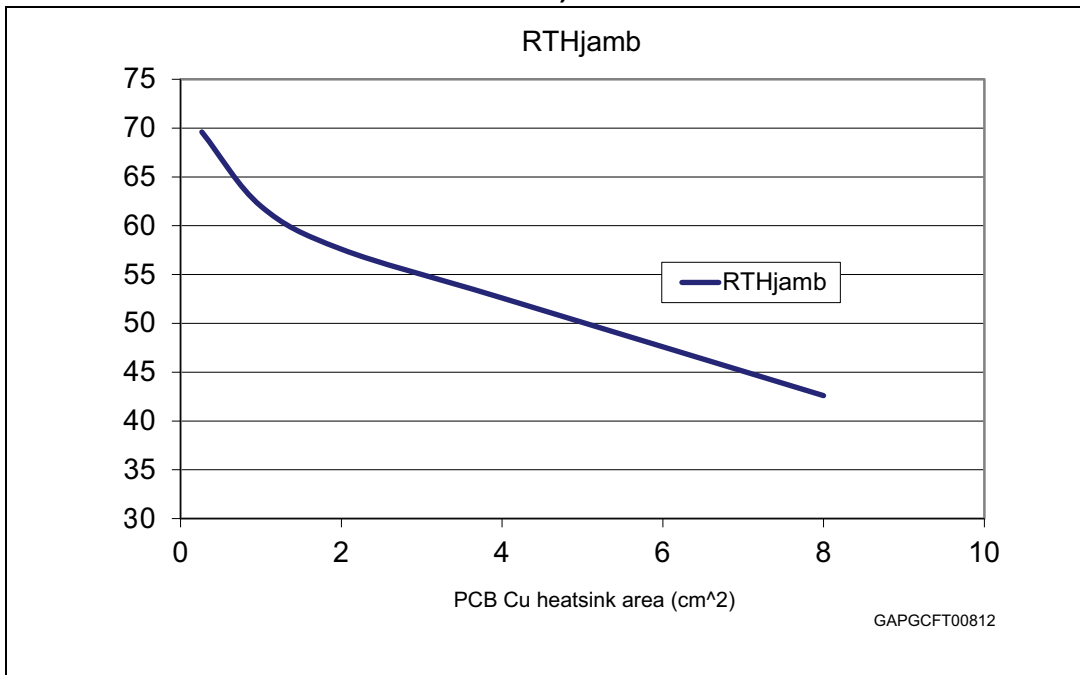

Figure 28. HPAK thermal impedance junction ambient single pulse (one channel ON)

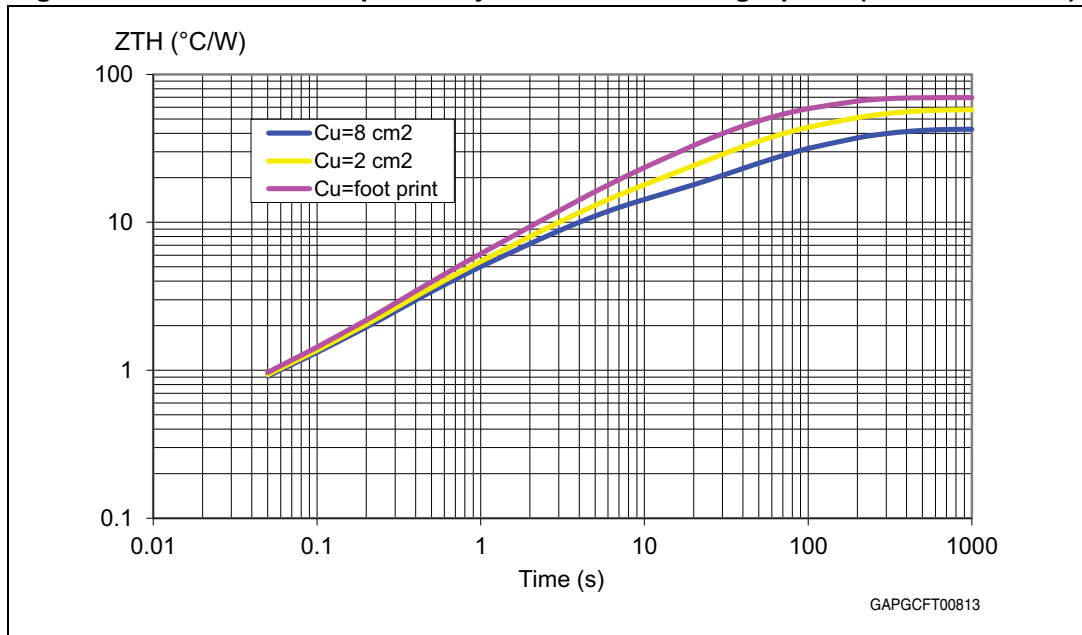
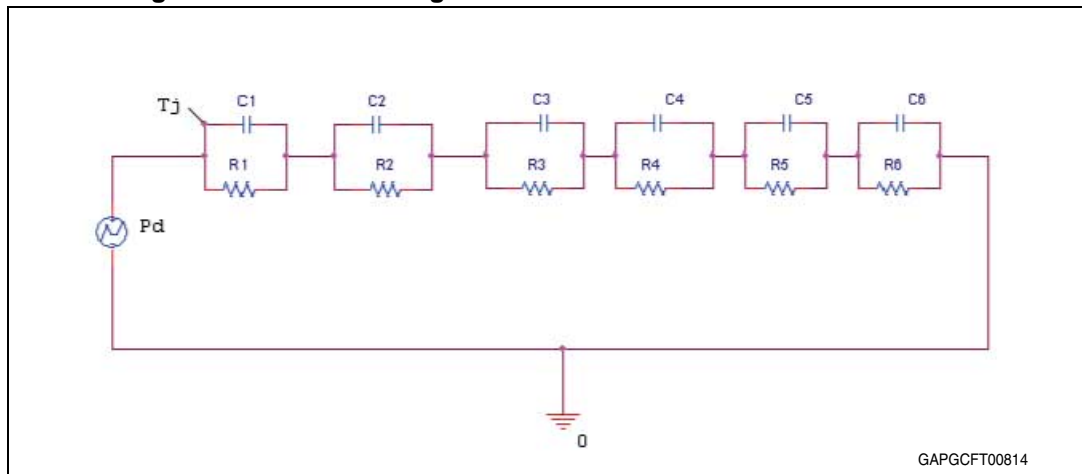

Figure 29. Thermal fitting model of a double channel HSD in HPAK



1. The fitting model is a simplified thermal tool and is valid for transient evolutions where the embedded protections (power limitation or thermal cycling during thermal shutdown) are not triggered.

Equation 2: pulse calculation formula

$$Z_{TH\delta} = R_{TH} \cdot \delta + Z_{THtp}(1 - \delta)$$

where $\delta = t_p/T$

Table 15. Thermal parameters

Area/island (cm ²)	Footprint	4	8
R1 (°C/W)	0.1		
R2 (°C/W)	0.5		
R3 (°C/W)	2		
R4 (°C/W)	8		
R5 (°C/W)	28	22	14
R6 (°C/W)	31	25	18
C1 (W.s/°C)	0.01		
C2 (W.s/°C)	0.05		
C3 (W.s/°C)	0.2		
C4 (W.s/°C)	0.4		
C5 (W.s/°C)	0.8	1.4	3
C6 (W.s/°C)	3	6	9

5 Package information

In order to meet environmental requirements, ST offers these devices in different grades of ECOPACK® packages, depending on their level of environmental compliance. ECOPACK® specifications, grade definitions and product status are available at: www.st.com.

ECOPACK® is an ST trademark.

5.1 HPAK mechanical data

Figure 30. HPAK package dimensions

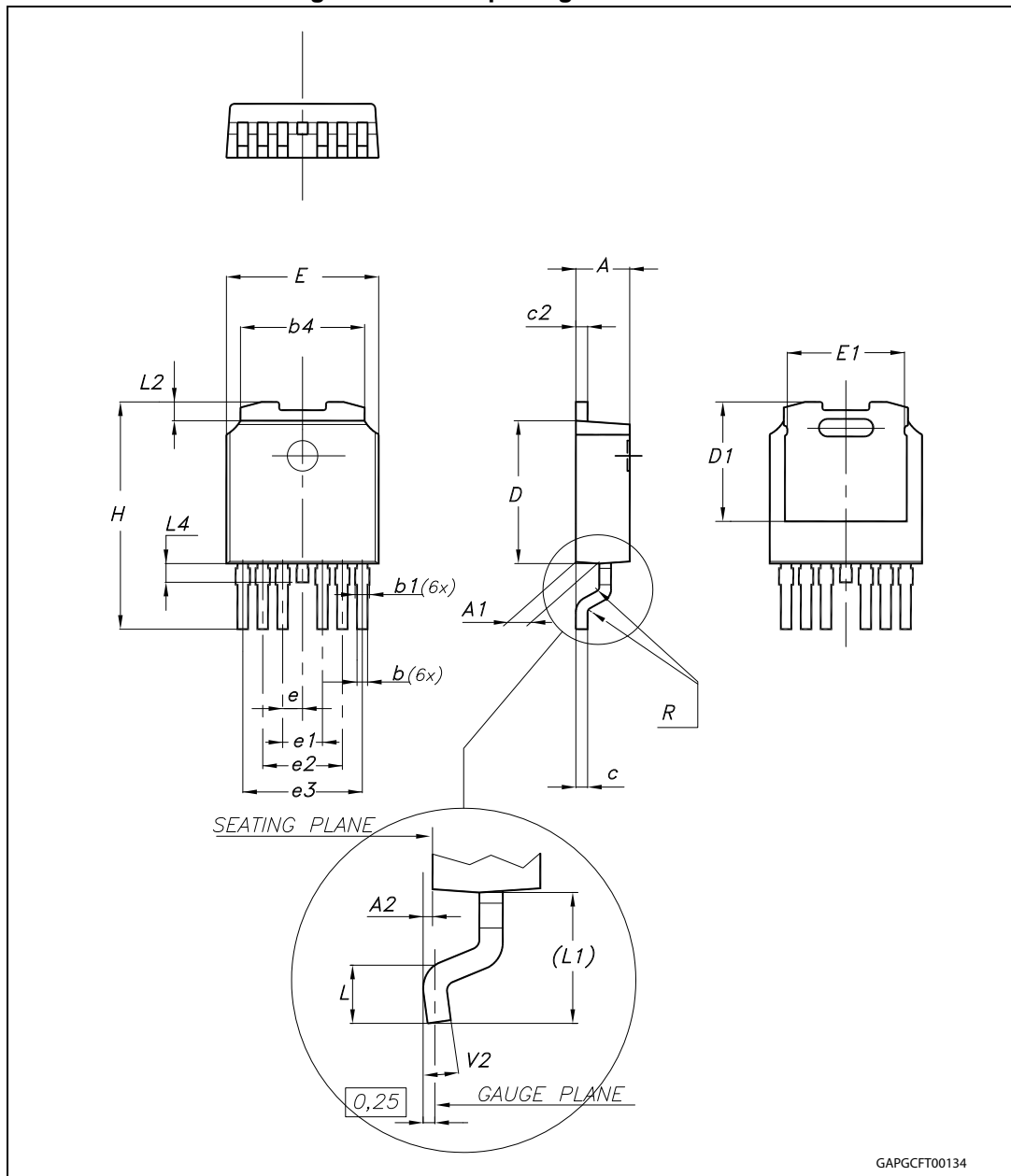

Table 16. HPAK mechanical data

Ref. dim	Data book mm		
	Min.	Typ.	Max.
A	2.20		2.40
A1	0.90		1.10
A2	0.03		0.23
b	0.40		0.60
b1	0.45		0.65
b4	5.20		5.40
c	0.45		0.60
c2	0.48		0.60
D	6.00		6.20
D1	4.95	5.10	5.25
E	6.40		6.60
E1	5.00	5.20	5.40
e		0.85	
e1	1.60		1.80
e2	3.30		3.50
e3	5.00		5.20
H	9.35		10.10
L	1.00		1.50
(L1)	2.60	2.80	3.00
L2	0.60	0.80	1.00
L4	0.50		1.00
R		0.20	
V2	0°		8°

5.2 Packing information

The devices can be packed in tube or tape and reel shipments (see [Table 17: Device summary](#)).

Figure 31. HPAK tube shipment (no suffix)

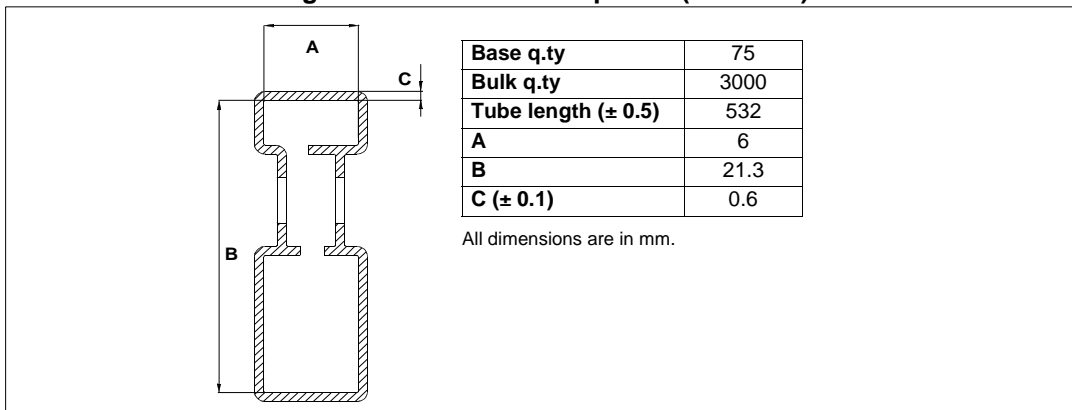
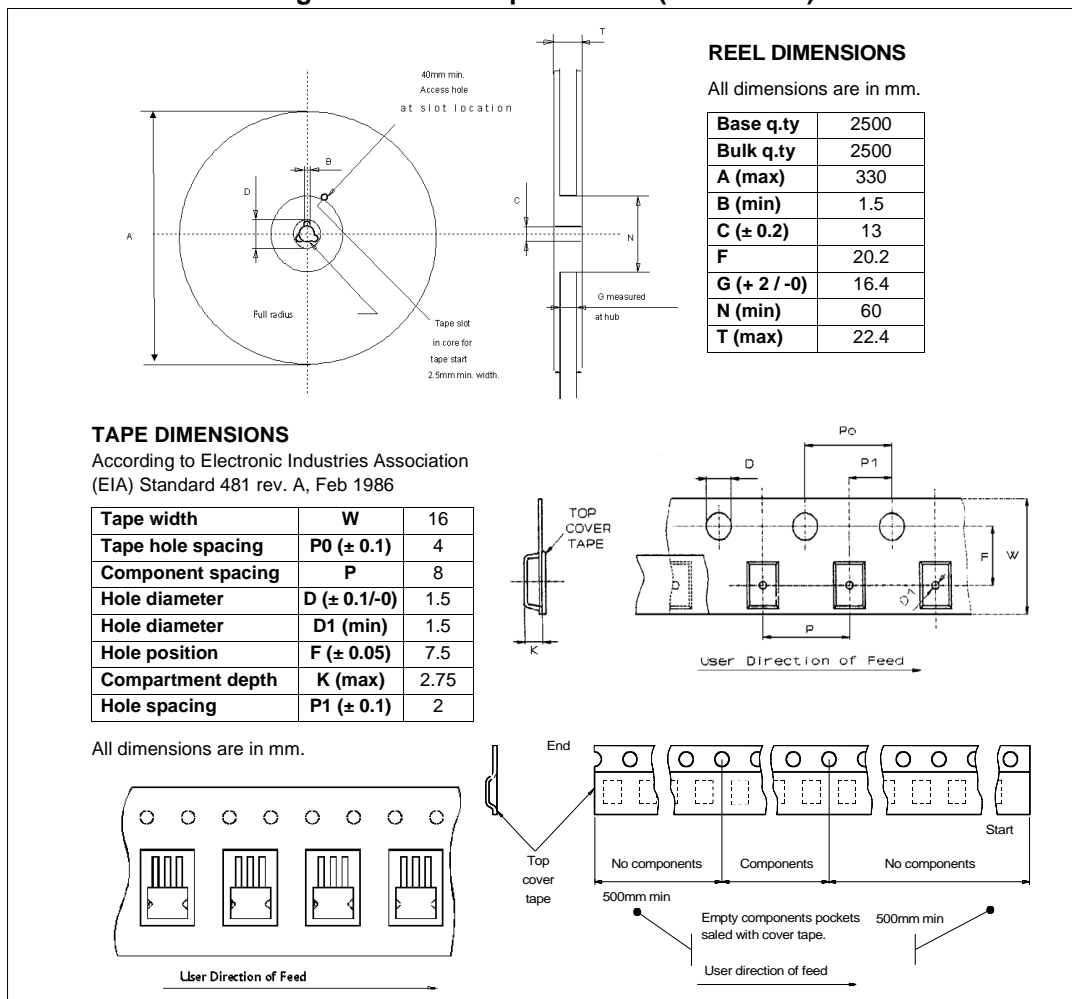

Figure 32. HPAK tape and reel (suffix "TR")



6 Order codes

Table 17. Device summary

Package	Order codes	
	Tube	Tape and reel
HPAK	VN5T016AH-E	VN5T016AHTR-E

7 Revision history

Table 18. Document revision history

Date	Revision	Changes
01-Oct-2012	1	Initial release.
17-Sep-2013	2	Updated disclaimer.
24-Feb-2016	3	<i>Table 4: Thermal data:</i> – $R_{thj-case}$: updated value Updated <i>Section 5.1: HPAK mechanical data</i>

IMPORTANT NOTICE – PLEASE READ CAREFULLY

STMicroelectronics NV and its subsidiaries ("ST") reserve the right to make changes, corrections, enhancements, modifications, and improvements to ST products and/or to this document at any time without notice. Purchasers should obtain the latest relevant information on ST products before placing orders. ST products are sold pursuant to ST's terms and conditions of sale in place at the time of order acknowledgement.

Purchasers are solely responsible for the choice, selection, and use of ST products and ST assumes no liability for application assistance or the design of Purchasers' products.

No license, express or implied, to any intellectual property right is granted by ST herein.

Resale of ST products with provisions different from the information set forth herein shall void any warranty granted by ST for such product.

ST and the ST logo are trademarks of ST. All other product or service names are the property of their respective owners.



Information in this document supersedes and replaces information previously supplied in any prior versions of this document.

© 2016 STMicroelectronics – All rights reserved







Looking for pricing, stock, or lifecycle information?

Click below to explore more details on WIN SOURCE:

-  [View VN5T016AH-E on WIN SOURCE](#)
-  [STMicroelectronics](#) Information

Optimize Your Supply Chain with WIN SOURCE Solutions

-  Global Sourcing Solution
-  Obsolete Management
-  Cost Control Management
-  Shortage Management
-  Alternative Solution
-  Excess Inventory Management