



**THE DATASHEET OF
NT3H2111W0FTTJ**



NT3H2111_2211

NTAG I²C *plus*: NFC Forum T2T with I²C interface, password protection and energy harvesting

Rev. 3.6 — 21 July 2023

Product data sheet



1 General description

Designed to be the perfect enabler for NFC in home-automation and consumer applications, this feature-packed, second-generation connected NFC tag is the fastest, least expensive way to add tap-and-go connectivity to just about any electronic device.

NXPNTAG I²C *plus* is a family of connected NFC tags that combine a passive NFC interface with a contact I²C interface. As the second generation of NXP's industry leading connected-tag technology, these devices maintain full backward compatibility with first-generation NTAG I²C products, while adding new, advanced features for password protection, full memory-access configuration from both interfaces, and an originality signature for protection against cloning.

The second-generation technology provides four times higher pass-through performance, along with energy harvesting capabilities, yet NTAG I²C *plus* devices are optimized for use in entry-level NFC applications and offer the lowest BoM of any NFC solution.

I²C and NFC communications are based on simple, standard command sets, and are augmented by the demo board OM5569/NT322E, which includes online reference source code. All that is required is a simple [antenna design](#), with no or only limited extra components, and there are plenty of reference designs online for inspiration. NTAG I²C *plus* development board is certified as NFC Forum Type 2 Tag ([Certification ID: 58514](#)).

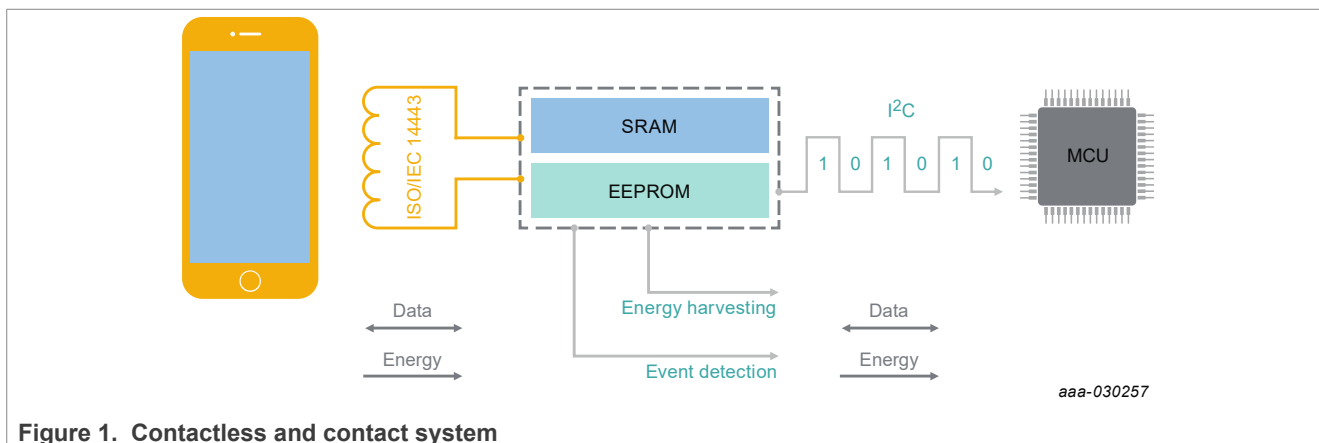

Figure 1. Contactless and contact system



2 Features and benefits

2.1 Key features

- Interoperability
 - [ISO/IEC 14443 Part 2](#) and 3 compliant
 - NTAG I²C *plus* development board is certified as NFC Forum Type 2 Tag ([Certification ID: 58514](#))
 - Unique 7 byte UID
 - GET_VERSION command for easy identification of chip type and supported features
 - Input capacitance of 50 pF
- Host interface
 - [I²C slave](#)
 - Configurable field detection pin based on open-drain implementation to signal NFC events or synchronize pass-through data transfer
- Memory
 - 2k bytes EEPROM
 - 64 bytes SRAM buffer for transfer of data between NFC and I²C interfaces with memory mirror or pass-through mode
 - Clear arbitration between NFC and I²C memory access
- Data transfer
 - Pass-through mode with 64 byte SRAM buffer
 - FAST_WRITE and FAST_READ NFC commands for higher data throughput
- Security and memory-access management
 - Full, read-only, or no memory access from NFC interface, based on 32-bit password
 - Full, read-only, or no memory access from I²C interface
 - NFC silence feature to disable the NFC interface
 - Originality signature based on Elliptic Curve Cryptography (ECC) for simple, genuine authentication
- Power Management
 - Configurable field-detection output signal for data-transfer synchronization and device wake-up
 - Energy harvesting from NFC field, so as to power external devices (e.g. connected microcontroller)
- Industrial requirements
 - Temperature range from -40 °C up to 105 °C

2.2 NFC interface

- [NFC Forum Type 2 Tag](#) compliant
- Contactless transmission of data at 106 kbit/s
- NTAG I²C *plus* development board is certified as NFC Forum Type 2 Tag ([Certification ID: 58514](#))
- [ISO/IEC 14443A](#) compliant
- Data transfer of 106 kbit/s
- 4 bytes (one page) written including all overhead in 4.8 ms via EEPROM or 0.8 ms via SRAM
- 64 bytes (whole SRAM) written including all overhead in 6.1 ms using FAST_WRITE command
- Data integrity of 16-bit CRC, parity, bit coding, bit counting
- Operating distance of up to 100 mm (depending on various parameters, such as field strength and antenna geometry)
- True anticollision
- Unique 7 byte serial number (UID) according to [ISO/IEC 14443-3](#)

2.3 Memory

- 2k bytes EEPROM
- 64 bytes SRAM volatile memory without write endurance limitation
- Data retention time of minimum 20 years
- EEPROM write endurance minimum 500.000 cycles

2.4 I²C interface

- I²C [slave](#) interface supports frequencies up to 400 kHz
- Fail-safe I²C operation
- I²C slave supports 7-bit slave address.
- As the least significant R/W bit is used to indicate data transfer direction, default slave address 55h recalculates to an I²C write address AAh and an I²C read address ABh respectively.
- 16 bytes (one block) written in 4 ms (EEPROM) or 0.4 ms (SRAM)
- NTAG I²C *plus* can be used as standard I²C EEPROM and I²C SRAM

2.5 Security

- Manufacturer-programmed 7-byte UID for each device
- Capability container with one time programmable bits
- Field programmable read-only locking function per page for first 12 pages and per 16 (1k version) or 32 (2k version) pages for the extended memory section
- ECC-based originality signature
- 32-bit password protection to prevent unauthorized memory operations from NFC perspective may be enabled for parts of, or complete memory
- Access to password protected data area may be restricted from I²C perspective
- Pass-through and mirror mode operation may be password protected
- Protected data can be safeguarded against limited number of negative password authentication attempts

2.6 Key benefits

- Full interoperability with every NFC-enabled device
- Smooth end-user experience with super-fast data exchange (up to 40 kbit/s) via NFC and I²C interface
- Zero-power operation with non-volatile data storage
- Energy harvesting feature delivers up to 15 mW out of NFC field to power (parts of) host system
- Data protection to prevent unauthorized data manipulation
- Multi-application support, enabled by memory size and segmentation options
- Lowest bill of materials and smallest footprint for NFC wireless charging solution in embedded electronics

3 Applications

NXP NTAG I²C *plus* is a family of connected NFC tags that combine a passive NFC interface with a contact I²C interface. As the second generation of NXP's industry-leading connected-tag technology, these devices maintain full backward compatibility with first-generation NTAG I²C products, while adding new, advanced features for password protection, full memory-access configuration from both interfaces, and an originality signature for protection against cloning.

The second-generation technology provides four times higher pass-through performance, along with energy harvesting capabilities, yet NTAG I²C *plus* devices are optimized for use in NFC applications like:

- IoT nodes (home automation, smart home, etc.)
- Pairing and configuration of consumer applications
- NFC accessories (headsets, speakers, etc.)
- Wearable infotainment
- Fitness equipment
- Consumer electronics
- Healthcare
- Smart printers
- Meters
- Electronic shelf labels

4 Ordering information

Table 1. Ordering information

Orderable part number	Package		
	Name	Description	Version
NT3H2111W0 FHKH	XQFN8	Plastic, extremely thin quad flat package; no leads; 8 terminals; body 1.6 x 1.6 x 0.5 mm; 1k bytes memory, 50 pF input capacitance; 4000 pcs. on 7" reel	SOT902-3
NT3H2211W0 FHKH	XQFN8	Plastic, extremely thin quad flat package; no leads; 8 terminals; body 1.6 x 1.6 x 0.5 mm; 2k bytes memory, 50 pF input capacitance; 4000 pcs. on 7" reel	SOT902-3
NT3H2111W0FTTJ	TSSOP8	Plastic thin shrink small outline package; 8 leads; body width 3 mm; 1k bytes memory; 50 pF input capacitance; 2500 pcs. on 13" reel	SOT505-1
NT3H2211W0FTTJ	TSSOP8	Plastic thin shrink small outline package; 8 leads; body width 3 mm; 2k bytes memory; 50 pF input capacitance; 2500 pcs. on 13" reel	SOT505-1
NT3H2111W0FT1X	SO8	Plastic small outline package; 8 leads; body width 3.9 mm, 1k bytes memory; 50 pF input capacitance; 1000 pcs. on 7" reel	SOT96-1
NT3H2211W0FT1X	SO8	Plastic small outline package; 8 leads; body width 3.9 mm, 2k bytes memory; 50 pF input capacitance; 1000 pcs. on 7" reel	SOT96-1

5 Marking

Table 2. Marking codes

Orderable part number	Marking code		
	Line 1	Line 2	Line 3
NT3H2111W0FHKH	211	-	-
NT3H2211W0FHKH	221	-	-
NT3H2111W0FTTJ	32111	DBSN ASID	YWW
NT3H2211W0FTTJ	32211	DBSN ASID	YWW
NT3H2111W0FT1X	NT32111	DBSN ASID	nDYWW
NT3H2211W0FT1X	NT32211	DBSN ASID	nDYWW

Used abbreviations:

DBSN: Diffusion Batch Sequence Number

ASID: Assembly Sequence ID

n: Assembly Centre Code

D: RHF-2006 indicator

Y: year

WW: week

6 Block diagram

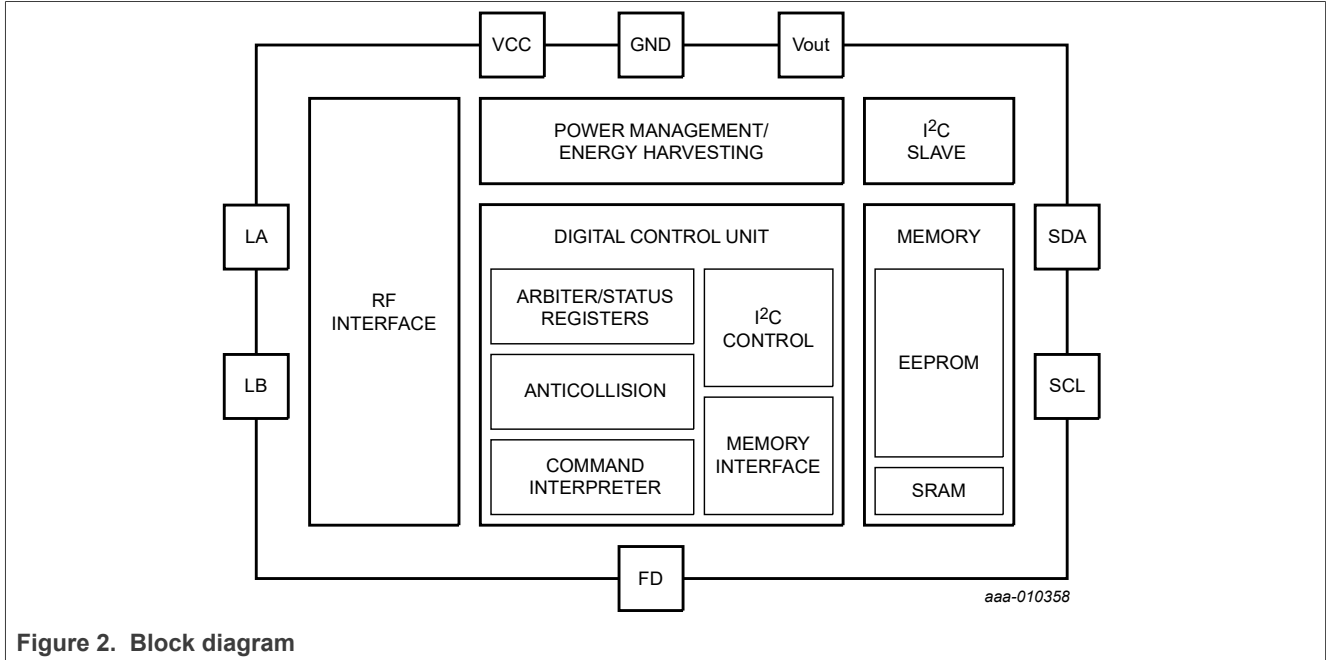

Figure 2. Block diagram

7 Pinning information

7.1 Pinning

7.1.1 XQFN8

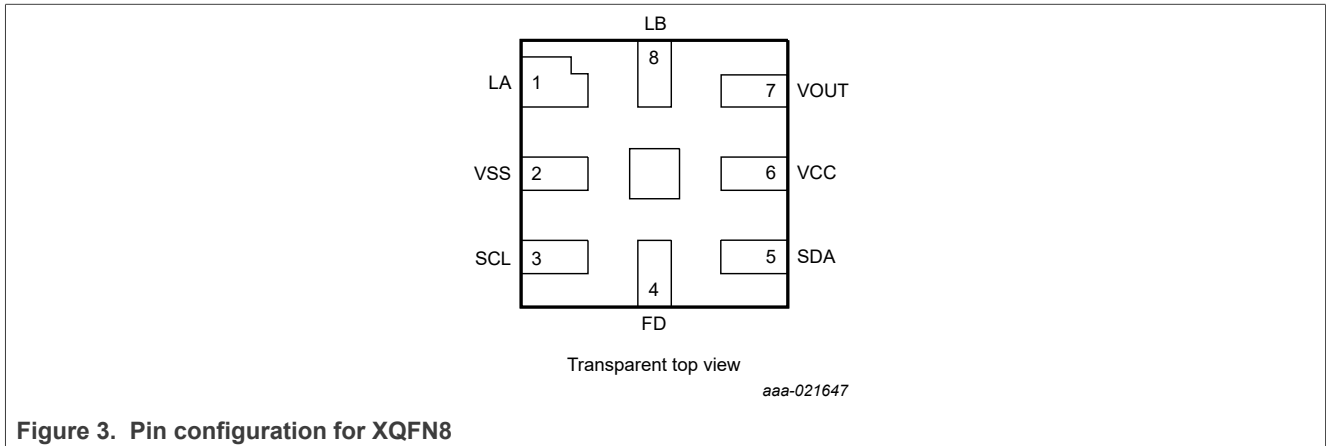

Figure 3. Pin configuration for XQFN8

Center pad - metal area - not for soldering.

Detailed package and soldering information may be found [here](#).

7.1.2 TSSOP8

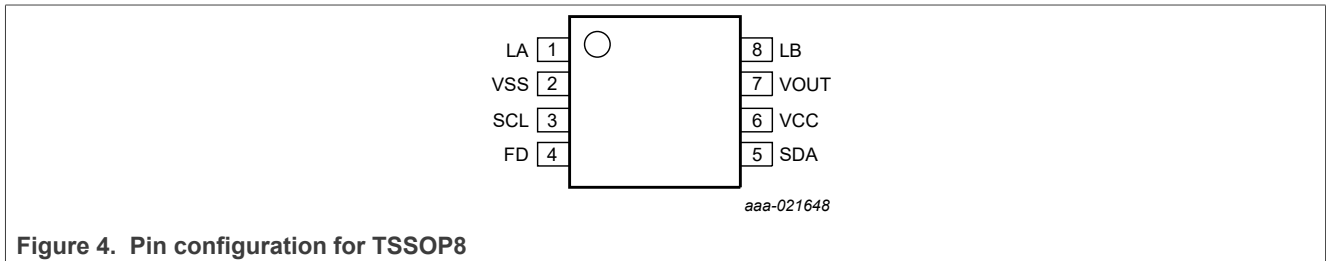

Figure 4. Pin configuration for TSSOP8

Detailed package and soldering information may be found [here](#).

7.1.3 SO8

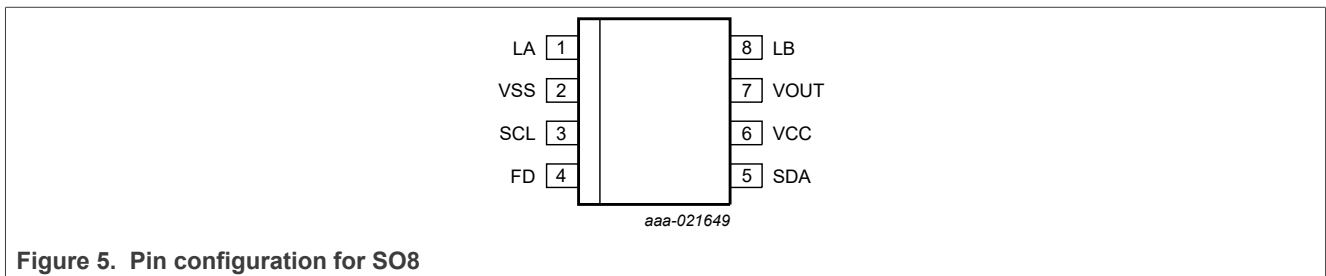

Figure 5. Pin configuration for SO8

Detailed package and soldering information may be found [here](#).

7.2 Pin description

Table 3. Pin description for XQFN8, TSSOP8 and SO8

Pin	Symbol	Description
1	LA	Antenna connection LA
2	VSS	GND
3	SCL	Serial clock I ² C
4	FD	Field detection
5	SDA	Serial data I ² C
6	VCC	VCC in connection (external power supply)
7	VOUT	Voltage out (energy harvesting)
8	LB	Antenna connection LB

8 Functional description

8.1 Block description

The NTAG I²C *plus* IC consist of EEPROM, SRAM, NFC interface, Digital Control Unit (Command interpreter, Anticollision, Arbiter/Status registers, I²C control and Memory Interface), Power Management and Energy Harvesting Unit and an I²C slave interface. Energy and data are transferred via an antenna consisting of a coil with a few turns, which is directly connected to NTAG I²C *plus* IC.

8.2 NFC interface

The passive NFC-interface is based on the [ISO/IEC 14443-3 Type A](#) standard.

It requires to be supplied by an NFC field (e.g. NFC enabled device) always to be able to receive appropriate commands and send the related responses.

As defined in ISO/IEC 14443-3 Type A for both directions of data communication, there is one start bit (start of communication) at the beginning of each frame. Each byte is transmitted with an odd parity bit at the end. The least significant bit of the byte 0 of the selected block is transmitted first.

For a multi-byte parameter, the least significant byte is always transmitted first. For example, when reading from the memory using the READ command, byte 0 from the addressed block is transmitted first, followed by bytes 1 to byte 3 out of this block. The same sequence continues for the next block and all subsequent blocks.

8.2.1 Data integrity

The following mechanisms are implemented in the contactless communication link between the NFC device and the NTAG I²C *plus* IC to ensure very reliable data transmission:

- 16 bits CRC per block
- Parity bits for each byte
- Bit count checking
- Bit coding to distinguish between "1", "0" and "no information"
- Channel monitoring (protocol sequence and bit stream analysis)

The commands are initiated by the NFC device and controlled by the Digital Control Unit of the NTAG I²C *plus* IC. The command response depends on the state of the IC, and for memory operations, the access conditions valid for the corresponding page.

8.2.2 NFC state machine

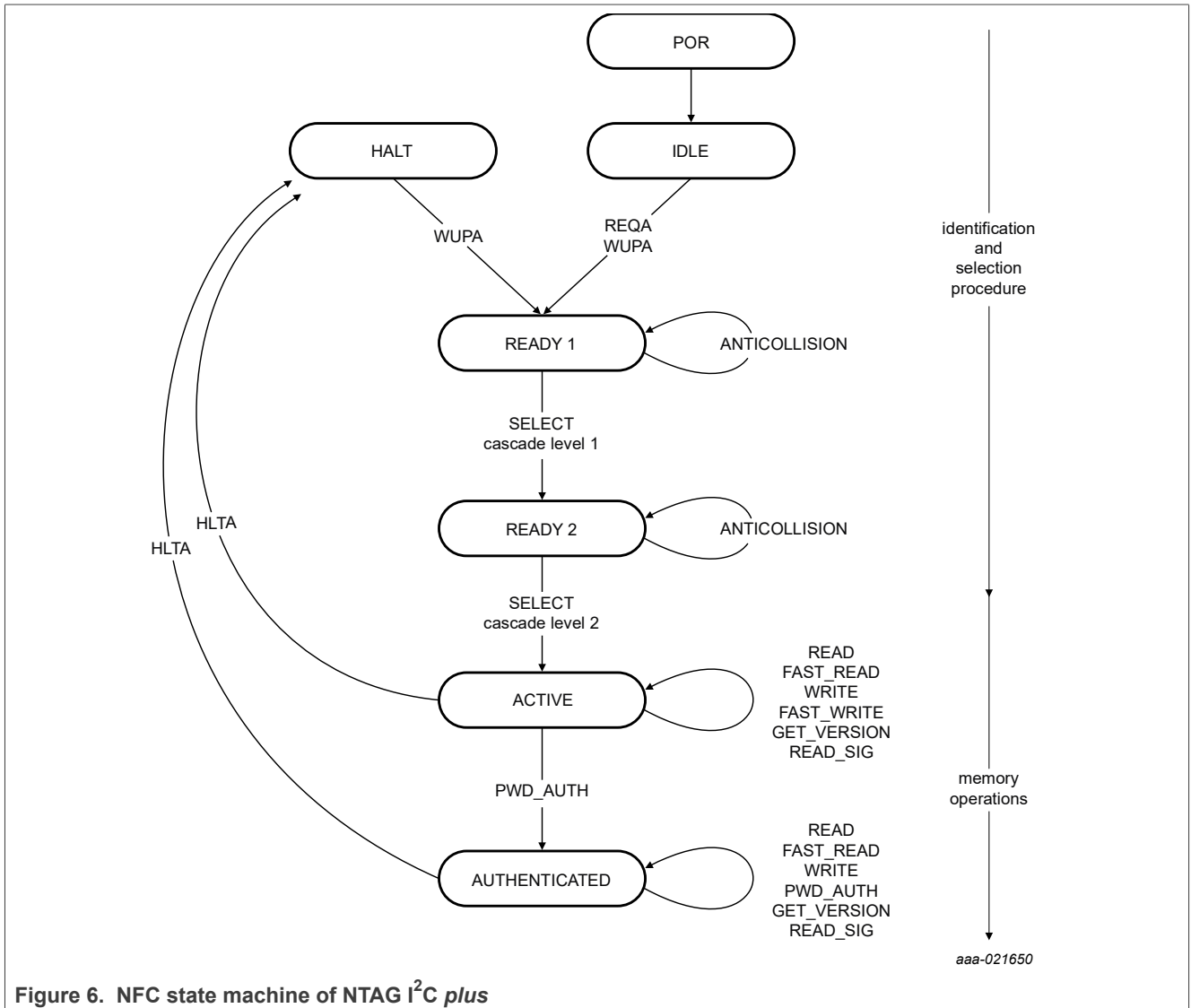

Figure 6. NFC state machine of NTAG I²C plus

The overall NFC state machine is summarized in [Figure 6](#). When an error is detected or an unexpected command is received, in each state the tag returns to IDLE or HALT state as defined in [ISO/IEC 14443-3 Type A](#).

8.2.2.1 IDLE state

After a Power-On Reset (POR), the NTAG I²C plus switches to the default waiting state, namely the IDLE state. It exits IDLE towards READY 1 state when a REQA or a WUPA command is received from the NFC device. Any other data received while in IDLE state is interpreted as an error, and the NTAG I²C plus remains in the IDLE state.

8.2.2.2 READY 1 state

In the READY 1 state, the NFC device resolves the first part of the UID (3 bytes) using the ANTICOLLISION or SELECT commands for cascade level 1. READY 1 state is correctly exited after.

- receiving SELECT command from cascade level 1 with the matching of complete first part of the UID. In this case, the NFC device switches the NTAG I²C *plus* into READY 2 state where the second part of the UID gets resolved.

Remark: The response of the NTAG I²C *plus* to the SELECT command is the Select Acknowledge (SAK) byte with cascade bit set to 1b indicating that UID is not complete.

8.2.2.3 READY 2 state

In the READY 2 state, the NFC device resolves the second part of the UID (4 bytes) using the ANTICOLLISION or SELECT command for cascade level 2. READY2 state is correctly exited after.

- receiving SELECT command from cascade level 2 with the matching of complete second part of the UID. In this case, the NFC device switches the NTAG I²C *plus* into ACTIVE state where all application-related commands can be executed.

Remark: The response of the NTAG I²C *plus* to the SELECT command in READY 2 state is the Select Acknowledge (SAK) byte with cascade bit cleared to indicate, that NTAG I²C *plus* is now uniquely selected and only this device will communicate with the NFC device even when other contactless devices are present in the NFC device field.

8.2.2.4 ACTIVE state

All unprotected memory operations are operated in the ACTIVE and AUTHENTICATED states.

The ACTIVE state is exited with the PWD_AUTH command or with the HLTA command.

Upon reception of a correct password within PWD_AUTH command, the NTAG I²C *plus* transits to AUTHENTICATED state after responding with PACK.

With the HLTA command, the NTAG I²C *plus* transits to the HALT state.

Any other invalid command in ACTIVE state is interpreted as an error. Depending on its previous state, the NTAG I²C *plus* returns to either to the IDLE or HALT state.

8.2.2.5 AUTHENTICATED state

Protected memory operations are only operated in the AUTHENTICATED state, however access to the unprotected memory is possible, too.

The AUTHENTICATED state is exited with the HLTA command and upon reception, the NTAG I²C *plus* transits to the HALT state.

Any other invalid command in AUTHENTICATED state is interpreted as an error. Depending on its previous state, the NTAG I²C *plus* returns to either to the IDLE or HALT state.

8.2.2.6 HALT state

HALT and IDLE states constitute the two waiting states implemented in the NTAG I²C *plus*. An already processed NTAG I²C *plus* in ACTIVE or AUTHENTICATED state can be set into the HALT state using the HLTA command. In the anticollision phase, this state helps the NFC device distinguish between processed tags and tags yet to be selected. The NTAG I²C *plus* can only exit HALT state upon execution of the WUPA command. Any other data received when the device is in this state is interpreted as an error, and NTAG I²C *plus* state remains unchanged.

8.3 Memory organization

The memory map is detailed in [Table 4](#) (1k memory) and [Table 5](#) (2k memory) from the NFC interface and in [Table 6](#) (1k memory) and [Table 7](#) (2k memory) from the I²C interface. The SRAM memory is only available and accessible when powered via VCC. Please refer to [Section 11](#) for examples of memory map from the NFC interface with SRAM mapping.

The structure of manufacturing data, static and dynamic lock bytes, capability container and user memory pages are compatible with other NTAG products.

Any memory access which starts at a valid address and extends into an invalid access region will return 00h value for the invalid region.

Bits and bytes marked as reserved for future use (RFU) SHALL NOT be changed, as it may lead to unintended tag behavior.

8.3.1 Memory map from NFC perspective

Memory access from the NFC perspective is organized in pages of 4 bytes each. If password protection is not used, complete user memory is unprotected.

NTAG I²C plus: NFC Forum T2T with I²C interface, password protection and energy harvesting

Table 4. NTAG I²C plus 1k memory organization from the NFC perspective

Sector address	Page address		Byte number within a page				Access cond. ACTIVE state	Access cond. AUTH. state						
	Dec.	Hex.	0	1	2	3								
0	0	00h	Serial number (UID)				READ							
	1	01h	Serial number (UID)			Internal	READ							
	2	02h	Internal		Static lock bytes		READ/R&W							
	3	03h	Capability Container (CC)				READ&WRITE							
	4	04h	Unprotected user memory				READ&WRITE							
												
	AUTH0	AUTH0												
	Protected user memory				READ ¹	READ&WRITE						
	225	E1h												
	226	E2h							Dynamic lock bytes		00h		R&W/READ	
	227	E3h	RFU	RFU	RFU	AUTH0	READ ¹	READ&WRITE						
	228	E4h	ACCESS	RFU	RFU	RFU	READ ¹	READ&WRITE						
	229	E5h	PWD ²				READ ¹	READ&WRITE						
	230	E6h	PACK ²		RFU	RFU	READ ¹	READ&WRITE						
	231	E7h	PT_I2C	RFU	RFU	RFU	READ ¹	READ&WRITE						
	232	E8h	Configuration registers				see Table 11							
	233	E9h												
	234	EAh	Invalid access - returns NAK				n.a.							
	235	EBh												
	236	ECh	Session registers				see Table 12							
237	EDh													
238	EEh													
239	EFh	Invalid access - returns NAK				n.a.								
240	F0h													
...	...													
255	FFh	Invalid access - returns NAK				n.a.								
1	Invalid access - returns NAK				n.a.	
2						
3	0	00h	Invalid access - returns NAK				n.a.							
												
	248	F8h	Mirrored session registers				see Table 12							
	249	F9h												
	Invalid access - returns NAK				n.a.							
255	FFh													

¹ If NFC_PROT bit is set to 1b, NTAG I²C plus returns NAK, and Password authentication will not be effective.

Table 4. NTAG I²C *plus* 1k memory organization from the NFC perspective...continued

Sector address	Page address		Byte number within a page				Access cond. ACTIVE state	Access cond. AUTH. state
	Dec.	Hex.	0	1	2	3		
² On reading PWD or PACK, NTAG I ² C <i>plus</i> always returns 00h for all bytes								

Table 5. NTAG I²C plus 2k memory organization from the NFC perspective

Sector address	Page address		Byte number within a page				Access cond. ACTIVE state	Access cond. AUTH. state
	Dec.	Hex.	0	1	2	3		
0	0	00h	Serial number (UID)				READ	
	1	01h	Serial number (UID)			Internal	READ	
	2	02h	Internal		Static lock bytes		READ/R&W	
	3	03h	Capability Container (CC)				READ&WRITE	
	4	04h	Unprotected user memory				READ&WRITE	
						
	AUTH0	AUTH0						
	Protected user memory				READ ¹	READ&WRITE
	225	E1h						
	226	E2h						
	227	E3h	RFU	RFU	RFU	AUTH0	READ ¹	READ&WRITE
	228	E4h	ACCESS	RFU	RFU	RFU	READ ¹	READ&WRITE
	229	E5h	PWD ²				READ ¹	READ&WRITE
	230	E6h	PACK ²		RFU	RFU	READ ¹	READ&WRITE
	231	E7h	PT_I2C	RFU	RFU	RFU	READ ¹	READ&WRITE
	232	E8h	Configuration registers				see Table 11	
	233	E9h						
	234	EAh	Invalid access - returns NAK				n.a.	
	235	EBh						
	236	ECh	Session registers				see Table 12	
237	EDh							
238	EEh							
...	...	Invalid access - returns NAK				n.a.		
255	FFh							
1	0	00h	(Un-)protected user memory ^{3,4}				see protected user memory in Sector 0	
						
	255	FFh						
2	Invalid access - returns NAK				n.a.	
3	0	00h	Invalid access - returns NAK				n.a.	
						
	248	F8h	Mirrored session registers				see Table 12	
	249	F9h						
	Invalid access - returns NAK				n.a.	
255	FFh							

¹ If NFC_PROT bit is set to 1b, NTAG I²C plus returns NAK, and Password authentication will not be effective.

NTAG I²C *plus*: NFC Forum T2T with I²C interface, password protection and energy harvesting

Table 5. NTAG I²C *plus* 2k memory organization from the NFC perspective...continued

Sector address	Page address		Byte number within a page				Access cond. ACTIVE state	Access cond. AUTH. state
	Dec.	Hex.	0	1	2	3		
² On reading PWD or PACK, NTAG I ² C <i>plus</i> always returns 00h for all bytes ³ If 2K_PROT bit is set to 1b, complete Sector 1 of NTAG I ² C <i>plus</i> is password protected ⁴ If NFC_DIS_SEC1 bit is set to 1b, complete Sector 1 of NTAG I ² C <i>plus</i> is not accessible from NFC perspective Remark: Although NTAG I ² C <i>plus</i> is fully compliant to the standard, some outdated mobiles might not parse it well.								

8.3.2 Memory map from I²C interface

The memory access of NTAG I²C *plus* from the I²C interface is organized in blocks of 16 bytes each.

I²C slave address is stored in most significant 7 bits of byte 0 in block 0. However, when reading block 0, NTAG I²C *plus* always returns 04h for byte 0.

WARNING: When configuring Static lock bytes and Capability container, Address byte gets updated, too. Address byte consists of slave address (coded in most significant 7 bits) and least significant bit set to 0b.

REMARK: For convenience reasons it is recommended to configure Address byte (block 0, byte 0) to 04h.

Table 6. NTAG I²C plus 1k memory organization from the I²C perspective

I ² C block address		Byte number within a block				Access conditions		
		0	1	2	3	I ² C_PROT		
		4	5	6	7			
		8	9	10	11	00b	01b	1xb
Dec.	Hex.	12	13	14	15			
0	00h	Addr. ¹	Serial number (UID)			READ&WRITE		
		Serial number (UID)			Internal			
		Internal		Static lock bytes				
		Capability Container (CC)						
1	01h	Unprotected user memory				READ&WRITE		
...	...							
AUTH0	AUTH0	Protected user memory				READ&WRITE	READ	NAK
...	...							
55	37h	Protected user memory				READ&WRITE	READ	NAK
56	38h	Protected user memory				READ&WRITE	READ	NAK
		Dynamic lock bytes			00h			
		RFU	RFU	RFU	AUTH0			
57	39h	ACCESS	RFU	RFU	RFU	READ&WRITE		
		PWD ²						
		PACK ²		RFU	RFU			
		PT_I2C	RFU	RFU	RFU			
58	3Ah	Configuration registers				see Table 11		
		00h	00h	00h	00h	READ		
		00h	00h	00h	00h			
59	3Bh	Invalid access - returns NAK				n.a.		
...	...							
247	F7h	SRAM memory (64 bytes)				READ&WRITE		
248	F8h							
251	FBh							
...	...	Invalid access - returns NAK				n.a.		
254	FEh	Session registers				see Table 12		
		00h	00h	00h	00h	READ		
		00h	00h	00h	00h			
255	FFh	Invalid access - returns NAK				n.a.		

¹ The byte 0 of block 0 is always read as 04h (UID0). Writing to block 0 updates the I²C address.

Table 6. NTAG I²C *plus* 1k memory organization from the I²C perspective...continued

I ² C block address		Byte number within a block				Access conditions		
		0	1	2	3	I ² C_PROT		
		4	5	6	7			
		8	9	10	11	00b	01b	1xb
Dec.	Hex.	12	13	14	15			

² On reading PWD and PACK, NTAG I²C *plus* always returns 00h for all bytes

Table 7. NTAG I²C plus 2k memory organization from the I²C perspective

I ² C block address		Byte number within a block				Access conditions		
		0	1	2	3	I ² C_PROT		
		4	5	6	7			
		8	9	10	11	00b	01b	1xb
Dec.	Hex.	12	13	14	15			
0	00h	Addr. ¹	Serial number (UID)			READ&WRITE		
		Serial number (UID)			Internal			
		Internal		Static lock bytes				
		Capability Container (CC)						
1	01h	Unprotected user memory				READ&WRITE		
...	...							
AUTH0	AUTH0	Protected user memory				READ&WRITE	READ	NAK
...	...							
56	38h	Protected user memory				READ&WRITE	READ	NAK
		Protected user memory						
		Dynamic lock bytes			00h	READ&WRITE		
		RFU	RFU	RFU	AUTH0			
57	39h	ACCESS	RFU	RFU	RFU	READ&WRITE		
		PWD ²						
		PACK ²		RFU	RFU			
		PT_I2C	RFU	RFU	RFU			
58	3Ah	Configuration registers				see Table 11		
		00h	00h	00h	00h	READ		
		00h	00h	00h	00h			
...	...	Invalid access - returns NAK				n.a.		
64	40h	(Un-)protected user memory				READ&WRITE	READ	NAK
...	...							
127	7Fh							
...	...	Invalid access - returns NAK				n.a.		
248	F8h	SRAM memory (64 bytes)				READ&WRITE		
...	...							
251	FBh							
...	...	Invalid access - returns NAK				n.a.		
254	FEh	Session registers				see Table 12		
		00h	00h	00h	00h	READ		
		00h	00h	00h	00h			

Table 7. NTAG I²C plus 2k memory organization from the I²C perspective...continued

I ² C block address		Byte number within a block				Access conditions		
		0	1	2	3	I ² C_PROT		
		4	5	6	7			
Dec.	Hex.	8	9	10	11	00b	01b	1xb
255	FFh	Invalid access - returns NAK						

¹ The byte 0 of block 0 is always read as 04h (UID0). Writing to block 0 updates the I²C address.
² On reading PWD and PACK, NTAG I²C plus always returns 00h for all bytes

8.3.3 EEPROM

The EEPROM is a non-volatile memory that stores the 7 byte UID, the memory lock conditions, IC configuration information and the user memory.

Sector 0 memory map looks totally the same for NTAG I²C plus 1k and 2k version, the only difference is the dynamic lock bit granularity.

NXP introduced with NTAG I²C plus the possibility to split the memory in an open and a password protected area see [Section 8.3.11](#).

8.3.4 SRAM

For frequently changing data, a volatile memory of 64 bytes with unlimited endurance is built in. The 64 bytes are mapped in a similar way as done in the EEPROM, i.e., 64 bytes are seen as 16 pages of 4 bytes from NFC perspective.

The SRAM is only available when the tag is powered via the VCC pin.

The SRAM is located at the end of the memory space and it is always directly accessible by the I²C host (addresses F8h to FBh). An NFC device cannot access the SRAM memory in normal mode (i.e., outside the pass-through mode). The SRAM is only accessible by the NFC device if the SRAM is mirrored onto the EEPROM memory space.

With SRAM mirror enabled (SRAM_MIRROR_ON_OFF = 1b - see [Section 11.2](#)), the SRAM can be mirrored in the User Memory from start page 01h to 74h for access from the NFC side.

The Memory mirror must be enabled once both interfaces are ON as this feature is disabled after each POR.

The register SRAM_MIRROR_BLOCK (see [Table 11](#)) indicates the address of the first page of the SRAM buffer. In the case where the SRAM mirror is enabled and the READ command is addressing blocks where the SRAM mirror is located, the SRAM byte values will be returned instead of the EEPROM byte values. Similarly, if the tag is not VCC powered, the SRAM mirror is disabled and reading out the bytes related to the SRAM mirror position would return the values from the EEPROM.

In the pass-through mode (PTHRU_ON_OFF = 1b - see [Table 11](#)), the SRAM is mirrored to the fixed address F0h - FFh for NFC access (see [Section 11](#)) in the first memory sector (Sector 0) of NTAG I²C plus.

8.3.5 Serial number (UID)

The unique 7 byte serial number (UID) is programmed into the first 7 bytes of memory covering page addresses 00h and 01h - see [Figure 7](#). These bytes are programmed and write protected during production.

UID0 is fixed to the value 04h - the manufacturer ID for NXP Semiconductors in accordance with [ISO/IEC 7816-6](#).

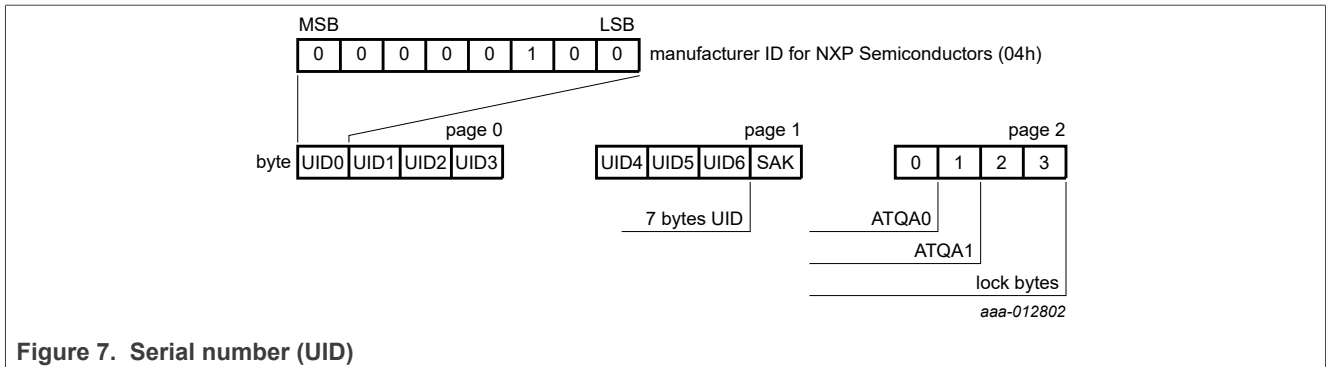

8.3.6 Static Lock Bytes

According to [NFC Forum Type 2 Tag](#) specification, the bits of byte 2 and byte 3 of page 02h (via NFC) or byte 10 and 11 address 00h (via I²C) represent the field programmable, read-only locking mechanism (see [Figure 8](#)). Each page from 03h (CC) to 0Fh can be individually locked by setting the corresponding locking bit to logic 1b to prevent further write access. After locking, the corresponding page becomes read-only memory.

This read only locking is address-based. This means, when SRAM is mirrored to these blocks, also SRAM blocks are read only from NFC perspective.

In addition, NTAG I²C plus uses the three least significant bits of lock byte 0 as the block-locking bits. Bit 2 controls pages 0Ah to 0Fh (via NFC), bit 1 controls pages 04h to 09h (via NFC) and bit 0 controls page 03h (CC). Once the block-locking bits are set, the locking configuration for the corresponding memory area is frozen, e.g. cannot be changed to read-only anymore.

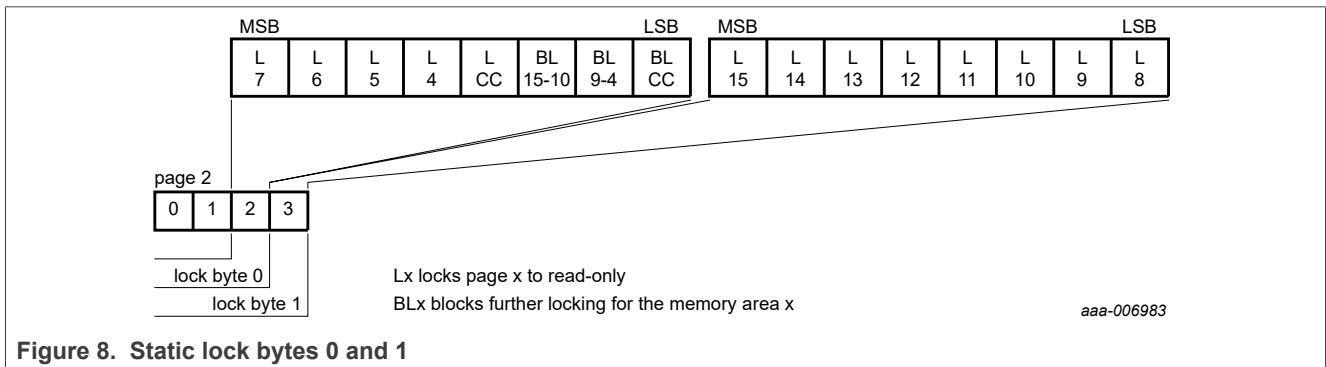

Figure 8. Static lock bytes 0 and 1

For example, if BL15-10 is set to logic 1b, then bits L15 to L10 (lock byte 1, bit[7:2]) can no longer be changed. The static locking and block-locking bits are set by the bytes 2 and 3 of the WRITE command to page 02h. The contents of the lock bytes are bit-wise OR'ed and the result then becomes the new content of the lock bytes. This process is irreversible from NFC perspective. If a bit is set to logic 1b, it cannot be changed back to logic 0b. From I²C perspective, the bits can be reset to 0b by writing bytes 10 and 11 of block 00h. As I²C address is coded in byte 0 of block 0, it may be changed unintentionally.

The contents of bytes 0 and 1 of page 02h (via NFC) are unaffected by the corresponding data bytes of the WRITE command.

The default value of the static lock bytes is 0000h.

8.3.7 Dynamic Lock Bytes

To lock the pages of NTAG I²C plus starting at page address 16 and onwards, the dynamic lock bytes are used. The dynamic lock bytes are located in Sector 0 at page E2h. The three lock bytes cover the memory area of

NTAG I²C plus: NFC Forum T2T with I²C interface, password protection and energy harvesting

840 data bytes (NTAG I²C plus 1k) or 1864 data bytes (NTAG I²C plus 2k). The granularity is 16 pages for NTAG I²C plus 1k (see [Figure 9](#)) and 32 pages for NTAG I²C plus 2k (see [Figure 10](#)) compared to a single page for the first 48 bytes.

NTAG I²C plus needs a Lock Control TLV as specified in [NFC Forum Type 2 Tag](#) specification to ensure NFC Forum Type 2 Tag compliancy.

When NFC Forum Type 2 Tag transition to READ ONLY state is intended, all bits marked as RFUI and dynamic lock bits related to the protected area shall be set to 0b when writing to the dynamic lock bytes.

The default value of the dynamic lock bytes is 000000h. The value of Byte 3 is always 00h.

Like for the static lock bytes, this process of modifying the dynamic lock bits is irreversible from NFC perspective and applies also for potentially mirrored SRAM. If a bit is set to logic 1b, it cannot be changed back to logic 0b. From I²C interface, these bits can be set to 0b again.

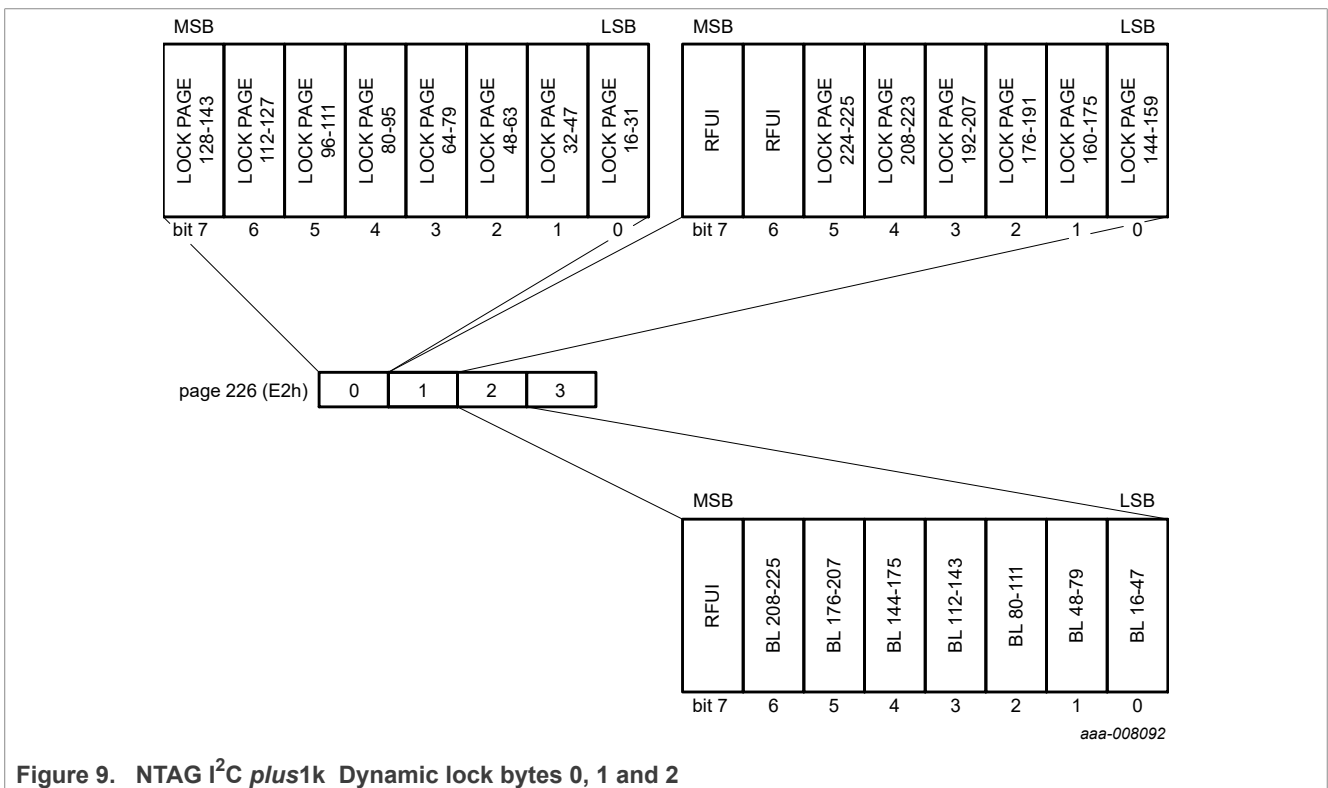
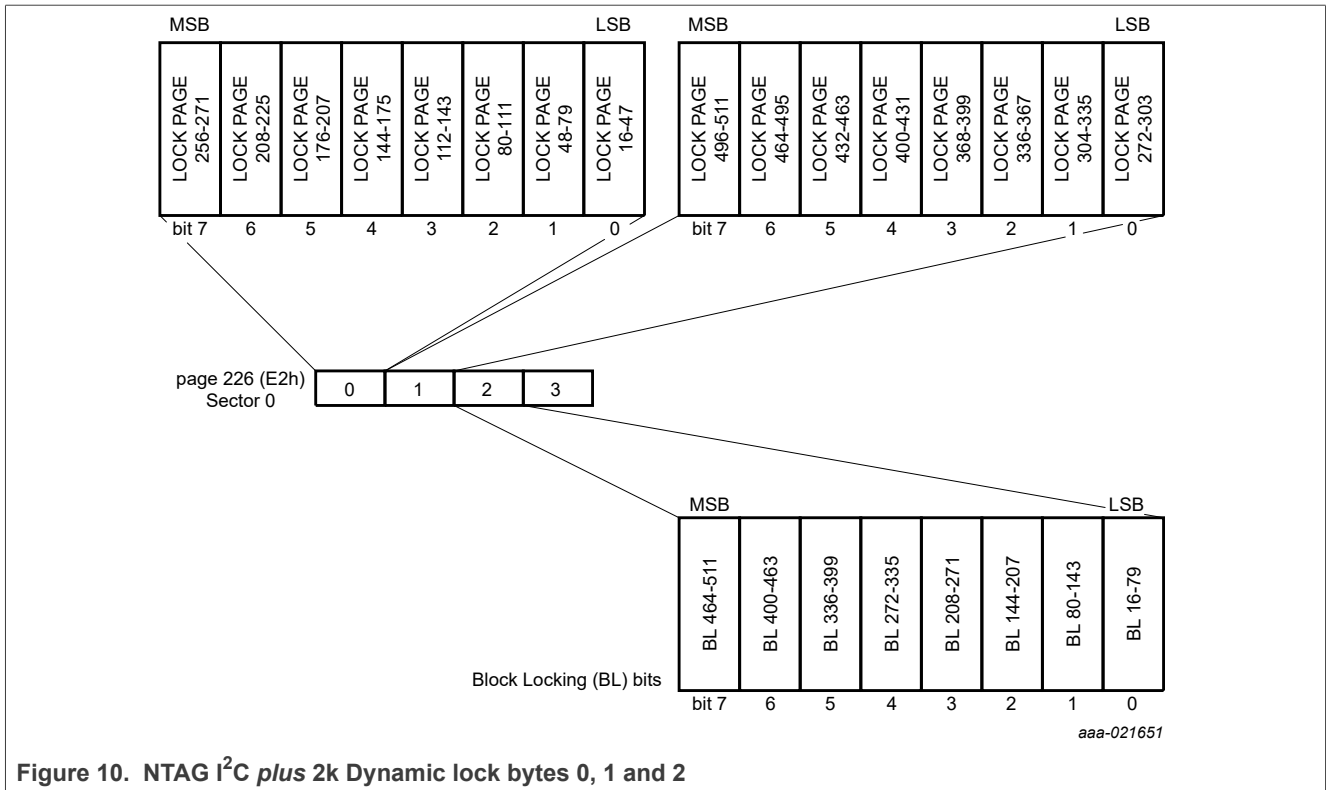

Figure 9. NTAG I²C plus1k Dynamic lock bytes 0, 1 and 2



8.3.8 Capability Container (CC)

According to [NFC Forum Type 2 Tag](#) specification the CC is located on page 03h. To keep full flexibility to split the memory into an open and protected area, the default value of the CC is initialized with 00000000h during the IC production.

NDEF messages can only be written with NFC Forum devices, after setting these CC bytes according to application-specific needs and NFC Forum specification by a WRITE command from the I²C or NFC interface. According to NFC Forum specification, a bit once set to 1b, an NFC Forum Device cannot set bits of the CC back to 0b. However, similar to the lock bits, setting these bits back to 0b is again possible from I²C perspective.

WARNING: As I²C address (byte 0) and static lock bytes (byte 10 and byte 11) are coded in block 00h from I²C side, the I²C address may be changed or the tag may be locked unintentionally, when changing CC.

REMARK: When reading out byte 0, NTAG I²C plus always returns 04h (UID0). Therefore, for convenience reasons it is recommended to configure I²C address byte to 04h.

NXP recommends setting the size parameter of the CC only to values that the T2T_Area ends at lock bit granularity boundaries when using only part of the memory for storing NDEF messages. Consequently T2T_Area size should be 112 + 64*N or 888 bytes with N less or equal to 13 for the 1k version, or 176 + 128*N or 2032 bytes with N less or equal to 14 for the 2k version.

In [Figure 11](#) it is shown how the CC is changed when going from READ/WRITE to READ ONLY state according to NFC Forum.

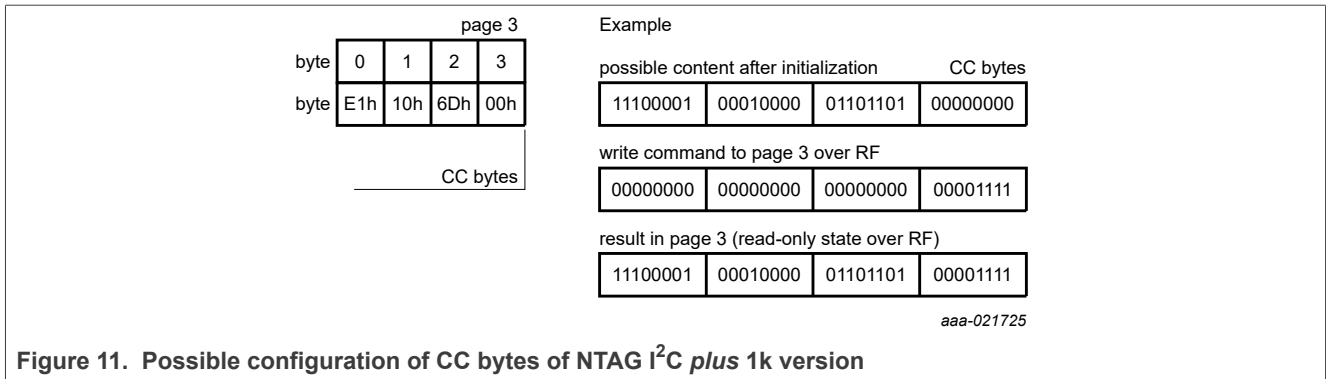

8.3.9 User Memory pages

Pages 04h to E1h of Sector 0 via the NFC interface - Block 01h to 37h, plus the first 8 bytes of block 38h via the I²C interface is the user memory area for NTAG I²C plus 1k and 2k version.

In addition, complete Sector 1 (page 00h to FFh) via the NFC interface - block 40h to 7Fh via the I²C interface is used as user memory area for NTAG I²C plus 2k version.

8.3.10 Memory content at delivery

As described above the CC in page 03h is set to all 00h to keep the full flexibility. To allow NFC Forum NDEF message reading and writing page 03h (CC) and the following data page (NDEF TLV) of NTAG I²C plus need to be initialized by the user according to the [NFC Forum Type 2 Tag](#) specification. [Table 8](#) shows an example of NFC Forum-compliant content using the whole memory of sector 0 for NDEF messages.

Remark: The default content of the data pages from page 04h onwards is not defined at delivery.

Table 8. Minimum memory content to be in initialized state for NTAG I²C plus

Page Address	Byte number within page			
	0	1	2	3
03h	E1h	10h	6Dh	00h
04h	03h	00h	FEh	00h

8.3.11 Password and Access Configuration

NTAG I²C plus can be configured to have password protected memory areas.

If this feature is used, NXP recommends changing and diversify the PWD and PACK for every single chip.

The password and access configuration area of pages E3h to E7h (Sector 0 - see [Table 9](#)) via the NFC interface or blocks 38h and 39h via the I²C interface are used to configure the password and access conditions of the NTAG I²C plus. Those bit values are stored in the EEPROM. Their values can be read and written by both interfaces when applicable and when not locked by the register lock bits (see REG_LOCK in [Table 11](#)).

AUTH0 defines the starting page address of the protected area in Sector 0. NXP recommends setting AUTH0 in a way always respecting the lock bit granularity. Setting AUTH0 greater EBh, disables password protection.

The NFC_PROT bit is used to either only require a PWD_AUTH for writing data to the protected area or even protect reading data from the protected area.

If password authentication is used, even the SRAM access can be protected by setting SRAM_PROT bit to 1b.

I2C_PROT enables the possibility to limit access to the protected area from I²C perspective to read only or no access at all.

AUTLIM value can be used to limit negative PWD_AUTH attempts.

For the 2k version of NTAG I²C *plus* NFC_DIS_SEC1 bit can be used to disable the access to Sector 1 from NFC perspective with the 2K_PROT bit password protection for Sector 1 can be enabled.

Once password protection is enabled, writing to Password and Access Configuration bytes is only possible after a successful password authentication. On reading the PWD or PACK, from NFC or I²C perspective, NTAG I²C *plus* always returns all 00h bytes.

A detailed description of the mechanism and how to program all the parameters is given in [Section 8.7](#).

Table 9. Password and Access Configuration Register

NFC page address (Sector 0)		I ² C block address		Byte number from NFC perspective			
Dec	Hex	Dec	Hex	0	1	2	3
224	E0h	56	38h	User Memory			
225	E1h						
226	E2h			Dynamic lock bytes			00h
227	E3h			RFU	RFU	RFU	AUTH0
228	E4h	57	39h	ACCESS	RFU	RFU	RFU
229	E5h			PWD			
230	E6h			PACK		RFU	RFU
231	E7h			PT_I2C	RFU	RFU	RFU

Table 10. Password and Access Configuration bytes

Bit	Field	Access via NFC	Access via I ² C	Default values	Description
Authentication Pointer (AUTH0)					
7-0	AUTH0	R&W	R&W	FFh	Page address of Sector 0 from which onwards the password authentication is required to access the user memory from NFC perspective, dependent on NFC_PROT bit. If AUTH0 is set to a page address greater than EBh, the password protection is effectively disabled. Password protected area starts from page AUTH0 and ends at page EBh. Password protection is excluded for Dynamic Lock Bits, session registers and mirrored SRAM pages. REMARK: From I ² C interface, you have access to all configuration pages until REG_LOCK_I2C bit is set to 1b.
Access Conditions (ACCESS)					
7	NFC_PROT	R&W	R&W	0b	Memory protection bit: 0b: write access to protected area is protected by the password 1b: read and write access to protected area is protected by the password
6	RFU	R&W	R&W	0b	RFU - SHALL be 0b
5	NFC_DIS_SEC1	R&W	R&W	0b	NFC access protection to Sector 1 0b: Sector 1 is accessible in 2k version 1b: Sector 1 in inaccessible and returns NAK0
4-3	RFU	R&W	R&W	00b	RFU - SHALL be 00b
2-0	AUTHLIM	R&W	R&W	000b	Limitation of negative password authentication attempts. After reaching the limit, protected area is not accessible any longer. 000b: limiting of negative password authentication attempts disabled. 001b-111b: maximum number of negative password authentication attempts is 2 ^{AUTHLIM}
Password (PWD)					
31-0	PWD	R&W	R&W	FFFFFFFFh	32-bit password used for memory access protection.

Table 10. Password and Access Configuration bytes...continued

Bit	Field	Access via NFC	Access via I ² C	Default values	Description
					Reading PWD always returns 00000000h
Password Acknowledge (PACK)					
15-0	PACK	R&W	R&W	0000h	16-bit password acknowledge used during the password authentication process. Reading PACK always returns 0000h
Protection bits (PT_I2C)					
7-4	RFU	R&W	R&W	0000b	RFU - SHALL be 0000b
3	2K_PROT	R&W	R&W	0b	Password protection for Sector 1 for 2k version 0b: password authentication for Sector 1 disabled 1b: password authentication needed to access Sector 1
2	SRAM_PROT	R&W	R&W	0b	Password protection for pass-through and mirror mode 0b: password authentication for pass-through mode disabled 1b: password authentication needed to access SRAM in pass-through mode
1-0	I2C_PROT	R&W	R&W	00b	Access to protected area from I ² C perspective 00b: Entire user memory accessible from I ² C 01b: read and write access to unprotected user area, read only access to protected area 1Xb: read and write access to unprotected area, no access to protected area. REMARK: Independent from these bits I ² C always has R&W access to: <ul style="list-style-type: none"> • Session registers • SRAM • Configuration pages including PWD Configuration area, but dependent on REG_LOCK_I2C bit

8.3.12 NTAG I²C plus configuration and session registers

NTAG I²C plus behavior can be configured and read in two separate locations depending if the configurations shall be effective within the communication session (use session registers) or by default after Power-On Reset (POR) (use configuration registers).

The configuration registers of pages E8h to E9h (Sector 0 - see [Table 11](#)) via the NFC interface or block 3Ah via the I²C interface are used to configure the default behavior of the NTAG I²C plus. Those bit values are stored in the EEPROM and represent the default settings to be effective after POR. Their values can be read and written by both interfaces when applicable and when not locked by the register lock bits (see REG_LOCK in [Table 13](#)).

Table 11. Configuration bytes NTAG I²C plus

NFC address (Sector 0)		I ² C Address		Byte number from NFC perspective			
Dec	Hex	Dec	Hex	0	1	2	3
232	E8h	58	3Ah	NC_REG	LAST_NDEF_BLOCK	SRAM_MIRROR_BLOCK	WDT_LS
233	E9h			WDT_MS	I2C_CLOCK_STR	REG_LOCK	RFU

The session register on pages ECh to EDh (Sector 0) via the NFC interface or block FEh via I²C, see [Table 12](#), are used to configure or monitor the values of the current communication session. Those bits are read only via the NFC interface but may be read and written via the I²C interface.

For backward compatibility reasons, the session registers are mirrored to Sector 3 (page F8h and F9h via the NFC interface).

Table 12. Session bytes NTAG I²C plus

NFC address (Sector 0)		I ² C Address		Byte number			
Dec	Hex	Dec	Hex	0	1	2	3
236	ECh	254	FEh	NC_REG	LAST_NDEF_BLOCK	SRAM_MIRROR_BLOCK	WDT_LS
237	EDh			WDT_MS	I2C_CLOCK_STR	NS_REG	RFU

Both, the session and the configuration registers have the same configuration options and parameters except the REG_LOCK bits, which are only available in the configuration register and the NS_REG bits which are only available in the session register. After POR, the content of the configuration register is loaded into the session register.

The values of both registers can be changed during a communication session. If the desired effect should be visible immediately, but only for the current communication session, the session registers must be used. After POR, the session registers values will again contain the configuration register values as before.

To change the default behavior, changes to the configuration register are needed, but the related effect will only be visible after the next POR.

To make the effect immediately and after next POR visible, changes to configuration and session registers are needed.

All registers and configuration default values, access conditions and descriptions are defined in [Table 13](#) and [Table 14](#).

Reading and writing the session registers via I²C can only be done via the READ and WRITE registers operation - see [Section 9.8](#).

Table 13. Configuration bytes

Bit	Field	Access via NFC	Access via I ² C	Default values	Description
Configuration register: NC_REG					
7	NFCS_I2C_RST_ON_OFF	R&W	R&W	0b	Enables the NFC disable feature and enables soft reset through I ² C repeated start - see Section 9.3
6	PTHRU_ON_OFF	R&W	R&W	0b	1b: pass-through mode using SRAM enabled and SRAM mapped to end of Sector 0. 0b: pass-through mode disabled
5-4	FD_OFF	R&W	R&W	00b	defines the event upon which the signal output on the FD pin is released 00b: if the field is switched off 01b: if the field is switched off or the tag is set to the HALT state 10b: if the field is switched off or the last page of the NDEF message has been read (defined in LAST_NDEF_BLOCK) 11b: (if FD_ON = 11b) if the field is switched off or if last data is read by I ² C (in pass-through mode NFC ---> I ² C) or last data is written by I ² C (in pass-through mode I ² C----> NFC) 11b: (if FD_ON = 00b or 01b or 10b) if the field is switched off See Section 8.4 for more details
3-2	FD_ON	R&W	R&W	00b	defines the event upon which the signal output on the FD pin is pulled low 00b: if the field is switched on 01b: by first valid start of communication (SoC) 10b: by selection of the tag 11b: (in pass-through mode NFC-->I ² C) if the data is ready to be read from the I ² C interface 11b: (in pass-through mode I ² C--> NFC) if the data is read by the NFC interface See Section 8.4 for more details
1	SRAM_MIRROR_ON_OFF	R&W	R&W	0b	1b: SRAM mirror enabled and mirrored SRAM starts at page SRAM_MIRROR_BLOCK 0b: SRAM mirror disabled
0	TRANSFER_DIR	R&W	R&W	1b	defines the data flow direction when pass-through mode is enabled 0b: from I ² C to NFC interface 1b: from NFC to I ² C interface In case the pass-through mode is NOT enabled, this bit should be set to 1b, otherwise there is no WRITE access from the NFC perspective
Configuration register: LAST_NDEF_BLOCK					
7-0	LAST_NDEF_BLOCK	R&W	R&W	00h	I ² C block address of I ² C block, which contains last byte(s) of stored NDEF message. An NFC read of the last page of this I ² C block sets the register NDEF_DATA_READ to 1b and triggers field detection pin if FD_OFF is set to 10b. Valid range starts

Table 13. Configuration bytes...continued

Bit	Field	Access via NFC	Access via I ² C	Default values	Description
					from 01h (NFC page 04h) up to 37h (NFC page DCh) NTAG I ² C <i>plus</i> 1k or up to 7Fh (NFC page FCh on Sector 1) for NTAG I ² C <i>plus</i> 2k.
Configuration register: SRAM_MIRROR_BLOCK					
7-0	SRAM_MIRROR_BLOCK	R&W	R&W	F8h	I ² C block address of SRAM when mirrored into the User memory. Valid range starts from 01h (NFC page 04h) up to 34h (NFC page D0h) NTAG I ² C <i>plus</i> 1k or up to 7Ch (NFC page F0h on memory Sector 1) for NTAG I ² C <i>plus</i> 2k
Configuration register: WDT_LS					
7-0	WDT_LS	R&W	R&W	48h	Least Significant byte of watchdog time control register
Configuration register: WDT_MS					
7-0	WDT_MS	R&W	R&W	08h	Most Significant byte of watchdog time control register. When writing WDT_MS byte, the content of WDT_MS and WDT_LS gets active for the watchdog timer.
Configuration register: I2C_CLOCK_STR					
7-1	RFU	R&W	R&W	0000000b	RFU - all 7 bits SHALL be 0b
0	I2C_CLOCK_STR	R&W	R&W	1b	Enables (1b) or disable (0b) the I ² C clock stretching
Configuration register: REG_LOCK					
7-2	RFU	R&W	R&W	000000b	RFU - all 6 bits SHALL be 0b
1	REG_LOCK_I2C ¹	R&W	R&W	0b	I ² C Configuration Lock Bit 0b: Configuration bytes may be changed via I ² C 1b: Configuration bytes cannot be changed via I ² C Once set to 1b, cannot be reset to 0b anymore.
0	REG_LOCK_NFC ¹	R&W	R&W	0b	NFC Configuration Lock Bit 0b: Configuration bytes may be changed via NFC 1b... Configuration bytes cannot be changed via NFC Once set to 1b, cannot be reset to 0b anymore.
¹ Setting both bits REG_LOCK_I2C and REG_LOCK_NFC to 1b, permanently locks write access to register default values (as no write is allowed anymore). As long as one bit is still 0b, the corresponding interface can still access and change the register lock bytes.					

Table 14. Session register bytes

Bit	Field	Access via NFC	Access via I ² C	Default values	Description
Session register: NC_REG					
7	NFCS_I2C_RST_ON_OFF	READ	R&W	-	see configuration bytes description
6	PTHRU_ON_OFF	READ	R&W	-	see configuration bytes description, the bit is cleared automatically, when one of the interfaces is OFF
5-4	FD_OFF	READ	R&W	-	see configuration bytes description
3-2	FD_ON	READ	R&W		
1	SRAM_MIRROR_ON_OFF	READ	R&W	-	see configuration bytes description, the bit is cleared automatically, when there is no Vcc power.
0	TRANSFER_DIR	READ	R&W		see configuration bytes description
Session register: LAST_NDEF_BLOCK					
7-0	LAST_NDEF_BLOCK	READ	R&W	-	see configuration bytes description
Session register: SRAM_MIRROR_BLOCK					
7-0	SRAM_MIRROR_BLOCK	READ	R&W	-	see configuration bytes description
Session register: WDT_LS					
7-0	WDT_LS	READ	R&W	-	see configuration bytes description
Session register: WDT_MS					
7-0	WDT_MS	READ	R&W	-	see configuration bytes description
Session register: I2C_CLOCK_STR					
7-2	RFU	READ	READ	-	RFU, all 6 bits locked to 0b
1	NEG_AUTH_REACHED	READ	READ	0b	Status bit to show the number of negative PWD_AUTH attempts reached 0b: PWD_AUTH still possible 1b: PWD_AUTH locked
0	I2C_CLOCK_STR	READ	READ	-	See configuration bytes description
Session register: NS_REG					
7	NDEF_DATA_READ	READ	READ	0b	1b: all data bytes read from the address specified in LAST_NDEF_BLOCK. Bit is reset to 0b when read
6	I2C_LOCKED	READ	R&W	0b	1b: Memory access is locked to the I ² C interface
5	RF_LOCKED	READ	READ	0b	1b: Memory access is locked to the NFC interface
4	SRAM_I2C_READY	READ	READ	0b	1b: data is ready in SRAM buffer to be read by I2C
3	SRAM_RF_READY	READ	READ	0b	1b: data is ready in SRAM buffer to be read by NFC
2	EEPROM_WR_ERR	READ	R&W	0b	1b: HV voltage error during EEPROM write or erase cycle Needs to be written back via I ² C to 0b to be cleared
1	EEPROM_WR_BUSY	READ	READ	0b	1b: EEPROM write cycle in progress - access to EEPROM disabled

Table 14. Session register bytes...continued

Bit	Field	Access via NFC	Access via I ² C	Default values	Description
					0b: EEPROM access possible
0	RF_FIELD_PRESENT	READ	READ	0b	1b: NFC field is detected

8.4 Configurable Field Detection Pin

The field detection pin based on open-drain implementation provides the capability to trigger an external device (e.g. μ Controller) or switch on the connected circuitry by an external power management unit depending on activities on the NFC interface.

As the field detection pin functionality is operated via NFC field power, V_{CC} supply for the tag itself is not required.

NOTE: In some cases V_{OUT} pin might be used as field detection trigger.

The conditions for pulling the field detection signal to low, FD_ON can be:

- The presence of the NFC field
- The detection of a valid command (Start of Communication)
- The selection of the IC

Remark: When FD_ON is configured to trigger on NFC field presence (00b), FD will be pulled low again, when host is reading the NDEF_DATA_READ bit of NS_REG session register from I²C perspective.

The conditions for releasing the field detection signal defined with FD_OFF can be:

- The absence of the NFC field
- The detection of the HALT state
- The NFC interface has read the last part of the NDEF message defined with LAST_NDEF_BLOCK

All the various combinations of configurations are described in [Table 13](#) and illustrated in the Figures below for all various combinations of the field detection signal configuration. The timing diagrams are not in scale and all given timing values are typical values.

The field detection pin can be used also as a handshake mechanism in the pass-through mode to signal to the external μ Controller if

- New data is written to SRAM on the NFC interface
- Data written to SRAM from the μ Controller is read via the NFC interface.

See [Section 11](#) for more information on this handshake mechanism.

In [Figure 12](#) an example how to connect the FD pin is given. All given values are typical values and may vary from application to application.

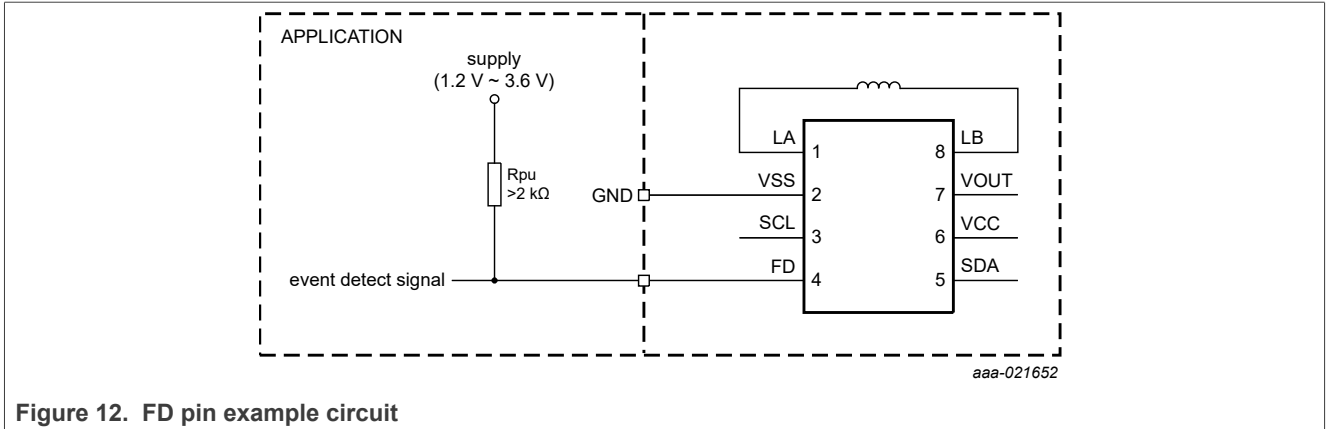

Figure 12. FD pin example circuit

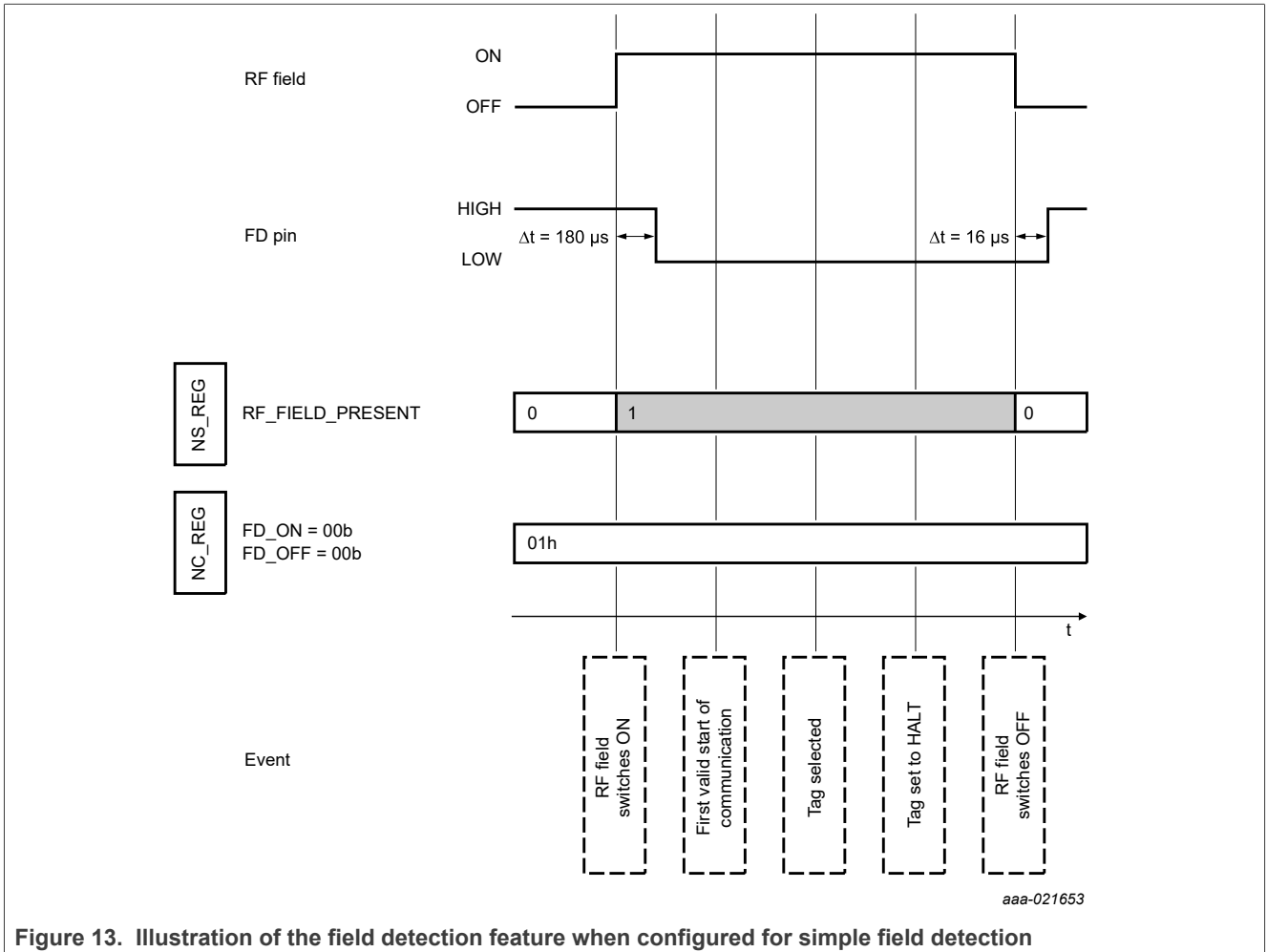

Figure 13. Illustration of the field detection feature when configured for simple field detection

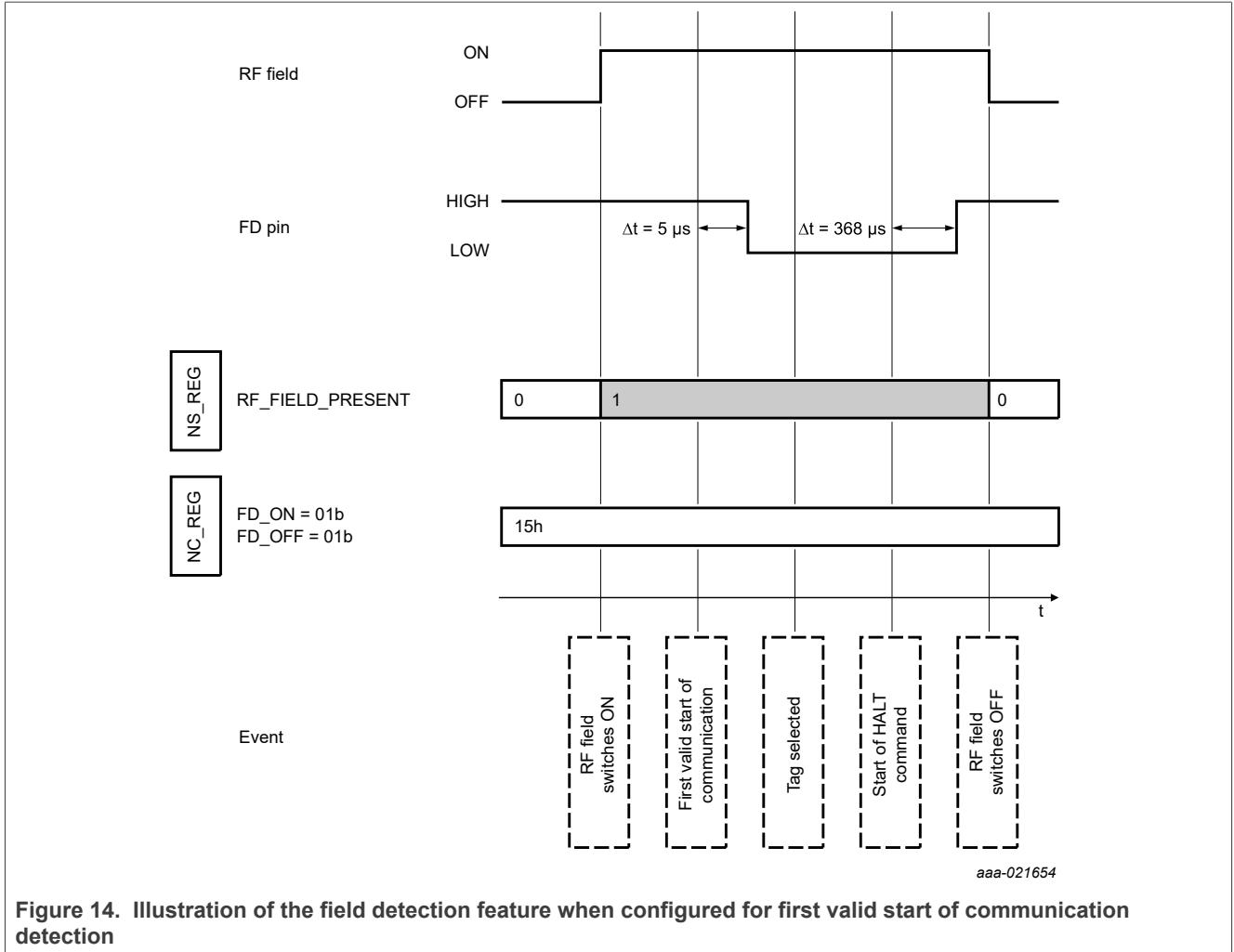

Figure 14. Illustration of the field detection feature when configured for first valid start of communication detection

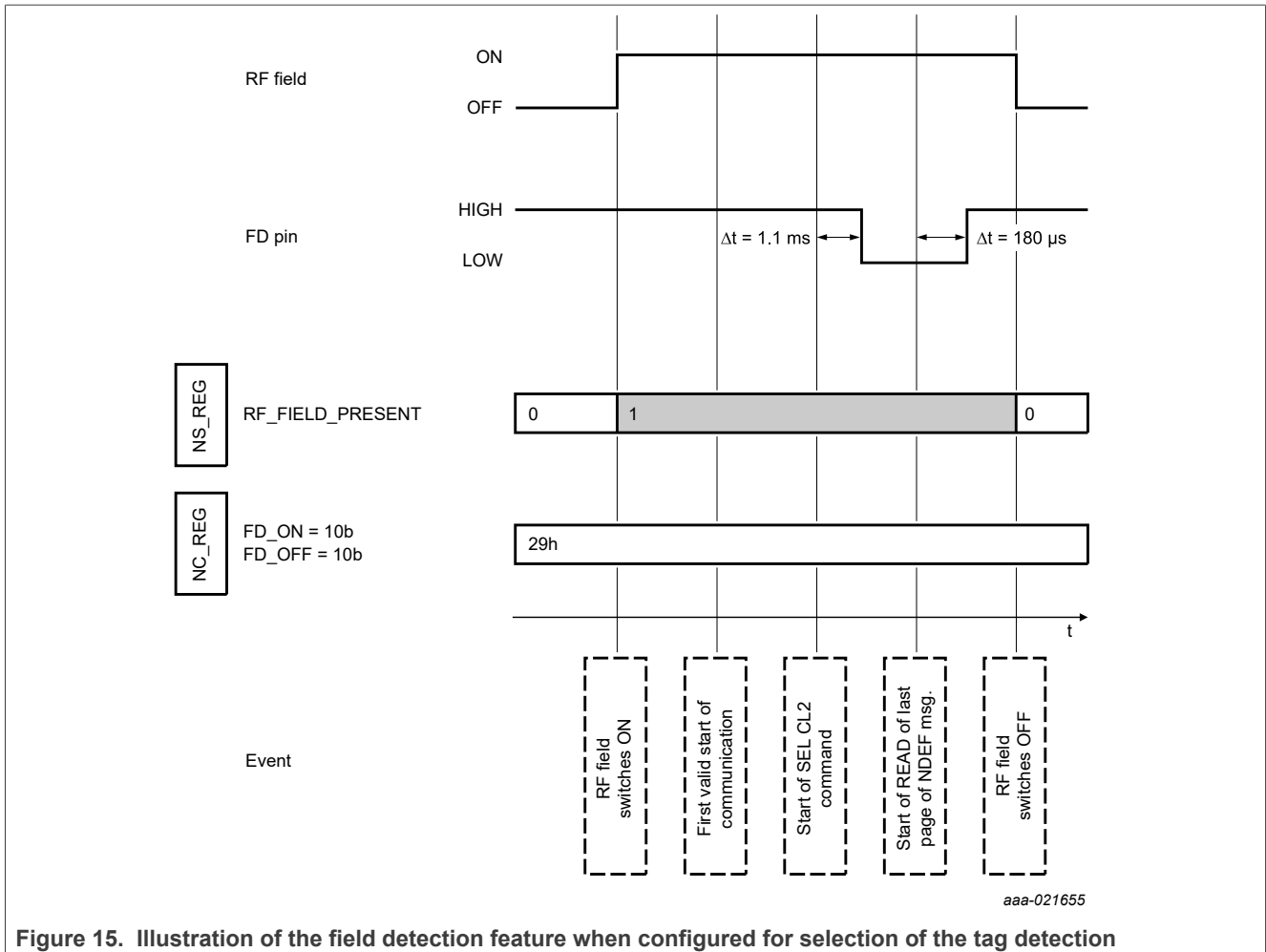

Figure 15. Illustration of the field detection feature when configured for selection of the tag detection

8.5 Watchdog timer

In order to allow the I²C interface to perform all necessary commands (READ, WRITE, ..), the memory access remains locked to the I²C interface until the register I2C_LOCKED is cleared by the host - see [Table 13](#).

However, to avoid that the memory stays 'locked' to the I²C for a long period of time, it is possible to program a watchdog timer to unlock the I²C host from the tag, so that the NFC device can access the tag after a period of time of inactivity. The host itself will not be notified of this event directly, but the NS_REG register is updated accordingly (the register bit I2C_LOCKED will be cleared - see [Table 13](#)).

The default value is set to 20 ms (848h), but the watchdog timer can be freely set from 0001h (9.43 μs) up to FFFFh (617.995 ms). The timer starts ticking when the communication between the NTAG I²C plus and the I²C interface starts. In case the communication with the I²C is still going on after the watchdog timer expires, the communication will continue until the communication has completed. Then the status register I2C_LOCKED will be immediately cleared.

In the case where the communication with the I²C interface has completed before the end of the timer and the status register I2C_LOCKED was not cleared by the host, it will be cleared at the end of the watchdog timer.

The watchdog timer is only effective if the VCC pin is powered and will be reset and stopped if the NTAG I²C plus is not VCC powered or if the register status I2C_LOCKED is set to 0 and RF_LOCKED is set to 1b.

8.6 Energy harvesting

The NTAG I²C plus provides the capability to supply external low-power devices with energy harvested from the NFC field of an NFC device as illustrated in [Figure 16](#). All given values are typical values. For more details, refer to the [energy harvesting](#) application note.

The voltage and current from the energy harvesting depend on various parameters, such as the strength of the NFC field, the tag antenna size, or the distance from the NFC device. NTAG I²C plus provides typically 5 mA at 2 V on the VOUT pin with an NFC Phone.

Operating NTAG I²C plus in energy harvesting mode requires a number of precautions:

- A complete total connected capacitor in the range of typically 150 nF up to 220 nF maximum shall be connected between VOUT and GND close to the terminals to ensure that the voltage does not drop below VCC min during modulation or during any application operation.
- Start up load current on VOUT should be limited until sufficient voltage is built on VOUT.
- If NTAG I²C plus also powers the I²C bus, then VCC must be connected to VOUT, and pull-up resistors on the SCL and SDA pins must be sized to control SCL and SDA sink current when those lines are pulled low by NTAG I²C plus or the I²C host
- If NTAG I²C plus also powers the Field Detect bus, then the pull-up resistor on the Field Detect line must be sized to control the sink current into the Field Detect pin when NTAG I²C plus pulls it low
- The NFC reader device communicating with NTAG I²C plus shall apply polling cycles including an NFC Field Off condition of at least 5.1 ms as defined in NFC Forum Activity specification.

REMARK: increasing the output current on V_{out} decreases the NFC communication range.

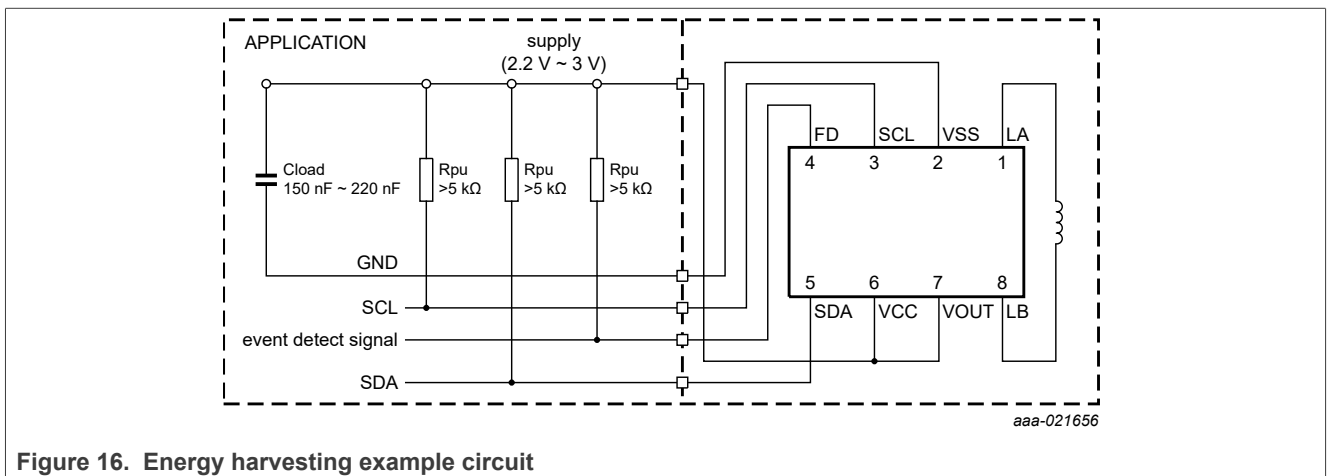

Figure 16. Energy harvesting example circuit

8.7 Password authentication

The memory write or read/write access to a configurable part of the memory can be constrained to a positive password authentication. The 32-bit secret password (PWD) and the 16-bit password acknowledge (PACK) response shall be typically programmed into the configuration pages at the tag personalization stage.

The AUTHLIM parameter specified in [Table 10](#) can be used to limit the negative authentication attempts.

In the initial state of NTAG I²C plus, password protection is disabled by an AUTH0 value of FFh. PWD and PACK are freely writable in this state. Access to the configuration pages and any part of the user memory can be restricted by setting AUTH0 to a page address within the available memory space. This page address is the first one protected.

For a comprehensive description of all protection mechanism, refer to the [application note](#).

Remark: The password protection method provided in NTAG I²C *plus* has to be intended as an easy and convenient way to prevent unauthorized memory accesses. If a higher level of protection is required, cryptographic methods can be implemented at application layer to increase overall system security.

8.7.1 Programming of PWD and PACK

The 32-bit PWD and the 16-bit PACK need to be programmed into the configuration pages, see [Table 9](#). The password as well as the password acknowledge are written LSByte first. This byte order is the same as the byte order used during the PWD_AUTH command and its response.

The PWD and PACK bytes can never be read out of the memory. Instead of transmitting the real value on any valid read command from both - NFC and I²C - interface, only 00h bytes are replied.

If the password authentication is disabled, PWD and PACK can be written at any time.

If the password authentication is enabled, PWD and PACK can be written after a successful PWD_AUTH command only.

Remark: To improve the overall system security, it is advisable to diversify the password and the password acknowledge using a die individual parameter of the IC, which can be the 7 byte UID available on NTAG I²C *plus*.

8.7.2 Limiting negative verification attempts

To prevent brute-force attacks on the password, the maximum allowed number of negative password authentication attempts can be set using AUTHLIM. This mechanism is disabled by setting AUTHLIM to a value of 000b, which is also the initial state of NTAG I²C *plus*.

If AUTHLIM is not equal to 000b, each negative authentication verification is internally counted. As soon as this internal counter reaches the number 2^{AUTHLIM} , any further negative password authentication leads to a permanent locking of the protected part of the memory for the specified access modes. Independently, whether the provided password is correct or not, each subsequent PWD_AUTH fails.

Any successful password verification, before reaching the limit of negative password verification attempts, resets the internal counter to zero.

8.7.3 Protection of configuration segments

The configuration pages can be protected by the password authentication as well. The protection level is defined with the NFC_PROT bit.

The protection is enabled by setting the AUTH0 byte (see [Table 9](#)) to a value that is within the addressable memory space.

8.8 Originality signature

NTAG I²C *plus* features a cryptographically supported originality check. With this feature, it is possible to verify that the tag is using an IC manufactured by NXP Semiconductors. This check can be performed on personalized tags as well.

NTAG I²C *plus* digital signature is based on standard Elliptic Curve Cryptography (ECC), according to the ECDSA algorithm. The use of a standard algorithm and curve ensures easy software integration of the originality check procedure in an application running on an NFC device without specific hardware requirements.

Each NTAG I²C *plus* UID is signed with an NXP private key and the resulting 32-byte signature is stored in a hidden part of the NTAG I²C *plus* memory during IC production.

This signature can be retrieved using the READ_SIG command and can be verified in the NFC device by using the corresponding ECC public key provided by NXP. In case the NXP public key is stored in the NFC device, the complete signature verification procedure can be performed offline.

To verify the signature (for example with the use of the public domain crypto library OpenSSL) the tool domain parameters shall be set to secp128r1, defined within the [standards for elliptic curve cryptography SEC](#).

Details on how to check the signature value are provided in corresponding [application note](#). It is foreseen to offer not only offline, as well as online way to verify originality of NTAG I²C *plus*.

9 I²C commands

For details about I²C interface, refer to the [NXP user manual](#).

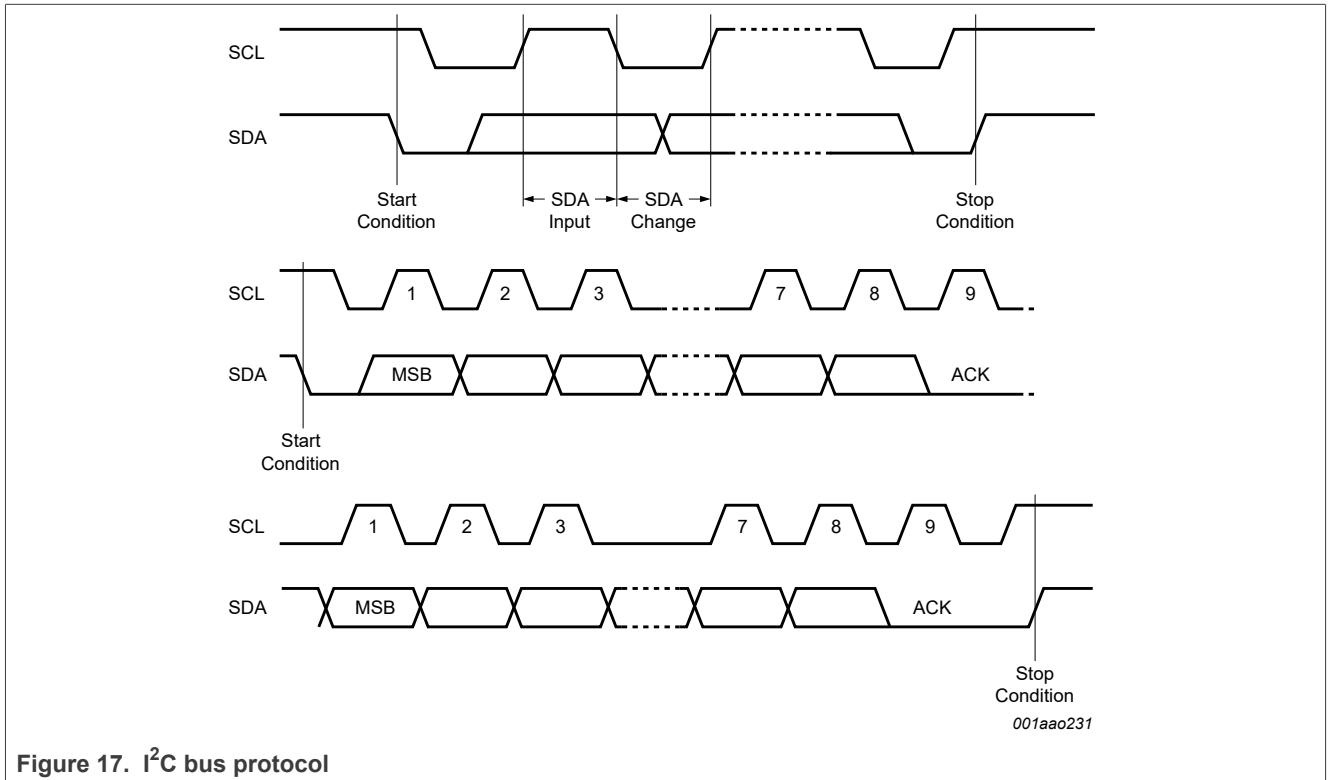

Figure 17. I²C bus protocol

The NTAG I²C plus supports the I²C protocol. This protocol is summarized in [Figure 17](#). Any device that sends data onto the bus is defined as a transmitter, and any device that reads the data from the bus is defined as a receiver. The device that controls the data transfer is known as the "bus master", and the other as the "slave" device. A data transfer can only be initiated by the bus master, which will also provide the serial clock for synchronization. The NTAG I²C plus is always a slave in all communications.

9.1 Start condition

Start is identified by a falling edge of Serial Data (SDA), while Serial Clock (SCL) is stable in the high state. A Start condition must precede any data transfer command. The NTAG I²C plus continuously monitors SDA (except during a Write cycle) and SCL for a Start condition, and will not respond unless one is given.

9.2 Stop condition

Stop is identified by a rising edge of SDA while SCL is stable and driven high. A Stop condition terminates communication between the NTAG I²C plus and the bus master. A Stop condition at the end of a Write command triggers the internal Write cycle.

WARNING: Host shall respect EEPROM programming time (~4 ms) after this Stop condition in any case. If host sends next command too early, the memory may be corrupted as ongoing EEPROM write cycle might get terminated.

9.3 I²C soft reset and NFC disable feature

With the bit `NFCS_I2C_RST_ON_OFF` (see [Table 13](#)) NTAG I²C *plus* enables two features: a soft reset of the I²C subsystem, and NFC disable, in which the NFC demodulator is disabled.

The I²C soft reset feature interprets an I²C repeated start (no I²C stop in between) as a command to execute a soft reset of the I²C subsystem. This is useful when heavy bus interference can cause the I²C interface to get stuck. A drawback of this feature is that every start symbol then has to be terminated with a Stop, slowing down communication. If a Stop is forgotten, the I²C interface is cleared and previous communication, if any, is lost. Consequently when this feature is used, stop conditions after MEMA for READ/WRITE (see [Figure 18](#)) and after REGA for READ/WRITE registers (see [Figure 19](#)) shall be send.

The NFC disable feature disables the demodulator. When feature is set, no NFC commands are received, and no replies are issued to commands that were not fully received when NFC disable was set. This feature allows the tag to "disappear" even if it still is in the reader field. NTAG I²C *plus* will remain in the ISO state it was in when NFC disable was enabled, until NFC disable is cleared.

The combination of these two features in a single bit means that I²C soft reset is only active during NFC disable.

9.4 Acknowledge bit (ACK)

The acknowledge bit is used to indicate a successful byte transfer. The bus transmitter, whether it is the bus master or slave device, releases Serial Data (SDA) after sending 8 bits of data. During the ninth clock pulse period, the receiver pulls Serial Data (SDA) low to acknowledge the receipt of the 9th data bits.

9.5 Data input

During data input, the NTAG I²C *plus* samples SDA on the rising edge of SCL. For correct device operation, SDA must be stable during the rising edge of SCL, and the SDA signal must change only when SCL is driven low.

9.6 Addressing

To start communication between a bus master and the NTAG I²C *plus* slave device, the bus master must initiate a Start condition (see [Section 9.1](#)). Following this initiation, the bus master sends the 7-bit device address, called Slave Address (SA) in following figures.

The 8th bit is the Read/Write bit (R/\overline{W}). This bit is set to 1b for Read and 0b for Write operations.

Default device address of 55h results in AAh default I²C write address and ABh default I²C read address.

As from I²C perspective I²C address can be configured via byte 0 of block 0. Reading this block gives 04h, as it is returning UID0 (see [Section 8.3.2](#)). Therefore it is recommended to us 04h as I²C write address (02h device address).

NOTE: Byte 0 of block 0 is used to configure the device address. The 7-bit device address needs to be programmed in the 7 most significant bits of this byte. Least significant bit needs to be set to 0b when programming the device address. E.g. to keep default device address of 55h, byte 0 of block 0 needs to be set to AAh.

If a match occurs on the device address, the NTAG I²C *plus* gives an acknowledgment on SDA during the 9th bit time. If the NTAG I²C *plus* address does not match, it deselects itself from the bus and clears the register `I2C_LOCKED` (see [Table 14](#)).

Table 15. Default NTAG I²C *plus* address from I²C

	Device / Slave Address (SA)							R/W
	b7	b6	b5	b4	b3	b2	b1	
Value ^[1]	1	0	1	0	1	0	1	1/0

[1] Initial values can be changed from I²C perspective

The I²C address of the NTAG I²C *plus* (byte 0 - block 0h) can only be modified by the I²C interface. Both interfaces cannot read the device address and a READ command from the NFC or I²C interface to this byte will return 04h (UID 0 - manufacturer ID for NXP Semiconductors - see [Figure 7](#)).

9.7 READ and WRITE Operation

NTAG I²C plus: NFC Forum T2T with I²C interface, password protection and energy harvesting

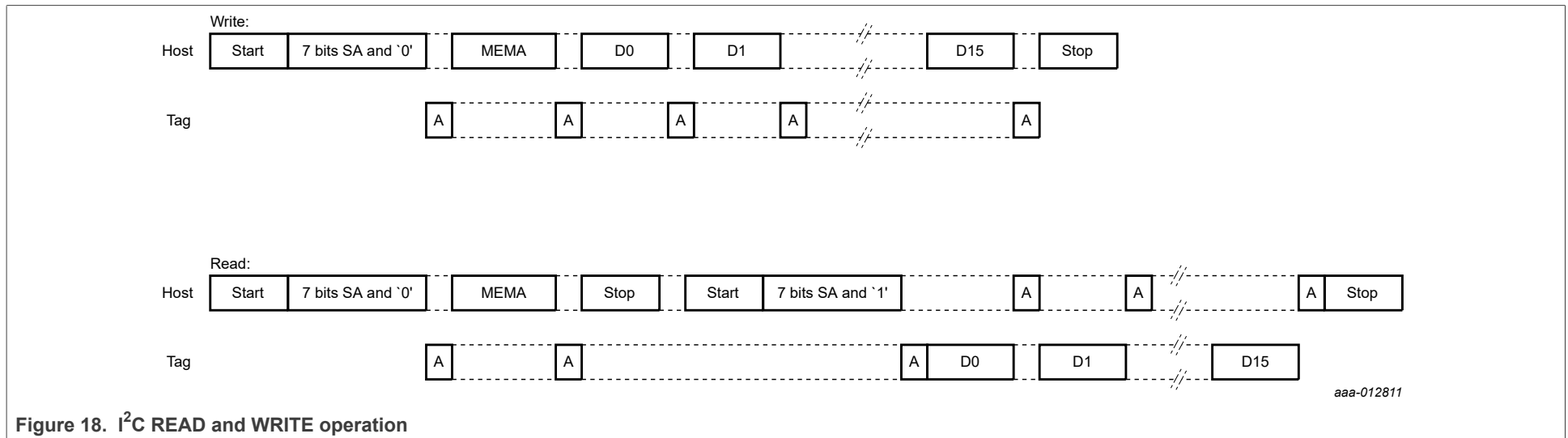

Figure 18. I²C READ and WRITE operation

The READ and WRITE operation always handle 16 bytes to be read or written (one block - see [Table 6](#))

For the READ operation (see [Figure 18](#)), following a Start condition, the bus master/host sends the NTAG I²C *plus* slave address code (SA - 7 bits) with the Read/Write bit (R/W) set to 0b. The NTAG I²C *plus* acknowledges this (A), and waits for one address byte (MEMA), which should correspond to the address of the block of memory (SRAM or EEPROM) that is intended to be read. The NTAG I²C *plus* responds to a valid address byte with an acknowledge (A). A Stop condition can be then issued. Then the host again issues a start condition followed by the NTAG I²C *plus* slave address with the Read/Write bit set to 1b. When I2C_CLOCK_STR is set to 0b, a pause of at least 50 μ s shall be kept before this start condition. The NTAG I²C *plus* acknowledges this (A) and sends the first byte of data read (D0). The bus master/host acknowledges it (A) and the NTAG I²C *plus* will subsequently transmit the following 15 bytes of memory read with an acknowledge from the host after every byte. After the last byte of memory data has been transmitted by the NTAG I²C *plus*, the bus master/host will acknowledge it and issue a Stop condition.

WARNING: READ sequence shall be atomic. Complete sequence of above figure needs to be executed, otherwise that tag may go to undefined state and stretches the clock infinitely.

For the WRITE operation (see [Figure 18](#)), following a Start condition, the bus master/host sends the NTAG I²C *plus* slave address code (SA - 7 bits) with the Read/Write bit (R/W) set to 0b. The NTAG I²C *plus* acknowledges this (A), and waits for one address byte (MEMA), which should correspond to the address of the block of memory (SRAM or EEPROM) that is intended to be written. The NTAG I²C *plus* responds to a valid address byte with an acknowledge (A) and, in the case of a WRITE operation, the bus master/host starts transmitting every 16 bytes (D0...D15) that shall be written at the specified address with an acknowledge of the NTAG I²C *plus* after each byte (A). After the last byte acknowledge from the NTAG I²C *plus*, the bus master/host issues a Stop condition.

WARNING: Host shall respect EEPROM programming time (~4 ms) after this Stop condition in any case. If host sends next command too early, the memory may be corrupted as ongoing EEPROM write cycle will get terminated.

The memory address accessible via the READ and WRITE operations can only correspond to the EEPROM or SRAM (respectively 00h to 3Ah or F8h to FBh for NTAG I²C *plus* 1k and 00h to 7Ah or F8h to FBh for NTAG I²C *plus* 2k).

9.8 WRITE and READ register operation

In order to modify or read the session register bytes (see Table 12), NTAG I²C plus requires the WRITE and READ register operation (see Figure 19).

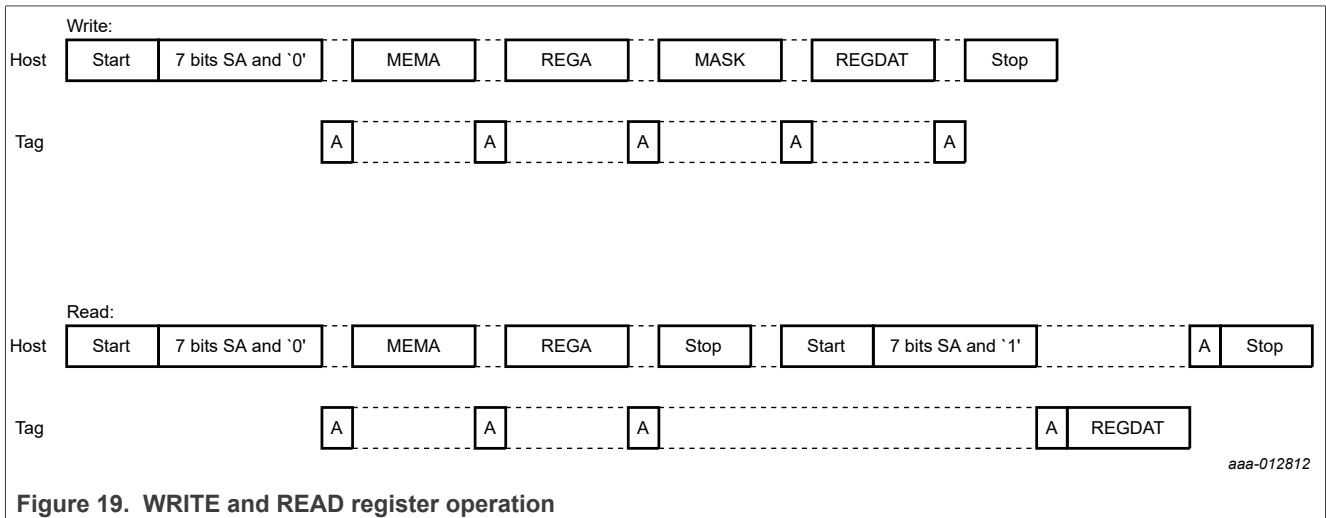

Figure 19. WRITE and READ register operation

For the READ register operation, following a Start condition the bus master/host sends the NTAG I²C plus slave address code (SA - 7 bits) with the Read/Write bit (R/W) set to 0b. The NTAG I²C plus acknowledges this (A), and waits for one address byte (MEMA) which corresponds to the address of the block of memory with the session register bytes (FEh). The NTAG I²C plus responds to the address byte with an acknowledge (A). Then the bus master/host issues a register address (REGA), which corresponds to the address of the targeted byte inside the block FEh (00h, 01h...to 07h) and then waits for the Stop condition.

Then the bus master/host again issues a start condition followed by the NTAG I²C plus slave address with the Read/Write bit set to 1b. The NTAG I²C plus acknowledges this (A), and sends the selected byte of session register data (REGDAT) within the block FEh. The bus master/host will acknowledge it and issue a Stop condition.

WARNING: READ sequence shall be atomic. Complete sequence of above figure needs to be executed, otherwise that tag may go to undefined state and stretches the clock infinitely.

For the WRITE register operation, following a Start condition, the bus master/host sends the NTAG I²C plus slave address code (SA - 7 bits) with the Read/Write bit (R/W) set to 0b. The NTAG I²C plus acknowledges this (A), and waits for one address byte (MEMA), which corresponds to the address of the block of memory within the session register bytes (FEh). After the NTAG I²C plus acknowledge (A), the bus master/host issues a register address (REGA), which corresponds to the address of the targeted byte inside the block FEh (00h, 01h...to 07h). After acknowledgment (A) by NTAG I²C plus, the bus master/host issues a MASK byte that defines exactly which bits shall be modified by a 1b bit value at the corresponding bit position. Following the NTAG I²C plus acknowledge (A), the new register data (one byte - REGDAT) to be written is transmitted by the bus master/host. The NTAG I²C plus acknowledges it (A), and the bus master/host issues a stop condition.

10 NFC Command

NTAG I²C plus activation follows the [ISO/IEC 14443-3](#) Type A [NFC Forum Activity](#) specification. After NTAG I²C plus has been selected, it can either be deactivated using the ISO/IEC 14443 HALT command, or NTAG commands (e.g. READ_SIG, PWD_AUTH, SECTOR_SELECT, READ or WRITE) can be performed. For more details about the card activation, refer to ISO/IEC 14443-3 or [NFC Forum Activity](#) specification.

10.1 NTAG I²C plus command overview

All available commands for NTAG I²C plus are shown in [Table 16](#).

Table 16. Command overview

Command ^[1]	ISO/IEC 14443	NFC Forum	Command code (hexadecimal)
Request	REQA	SENS_REQ	26h (7 bit)
Wake-up	WUPA	ALL_REQ	52h (7 bit)
Anticollision CL1	Anticollision CL1	SDD_REQ CL1	93h 20h
Select CL1	Select CL1	SEL_REQ CL1	93h 70h
Anticollision CL2	Anticollision CL2	SDD_REQ CL2	95h 20h
Select CL2	Select CL2	SEL_REQ CL2	95h 70h
Halt	HLTA	SLP_REQ	50h 00h
GET_VERSION	-	-	60h
READ	-	READ	30h
FAST_READ	-	-	3Ah
WRITE	-	WRITE	A2h
FAST_WRITE	-	-	A6h
SECTOR_SELECT	-	SECTOR_SELECT	C2h
PWD_AUTH	-	-	1Bh
READ_SIG	-	-	3Ch

[1] Unless otherwise specified, all commands use the coding and framing as described in [ISO/IEC 14443](#) or [NFC Forum Digital](#) specification.

10.2 Timing

The command and response timing shown in this document are not to scale and values are rounded to 1 µs.

All given command and response times refer to the data frames, including start of communication and end of communication. They do not include the encoding (like the Miller pulses). An NFC device data frame contains the start of communication (1 "start bit") and the end of communication (one logic 0 + 1-bit length of unmodulated carrier). An NFC tag data frame contains the start of communication (1 "start bit") and the end of communication (1-bit length of no subcarrier).

The minimum and maximum command response time is specified according to the standard. The minimum frame delay time from NFC tag to NFC device is 86.43 µs. The maximum command response time is specified as a timeout value. Depending on the command, the T_{ACK} value specified for command responses defines the NFC device to NFC tag frame delay time. It does it for either the 4-bit ACK value specified or for a data frame.

All timing can be measured according to the ISO/IEC 14443-3 frame specification as shown for the Frame Delay Time in [Figure 20](#). For more details, refer to [ISO/IEC 14443](#) or [NFC Forum](#) specification.

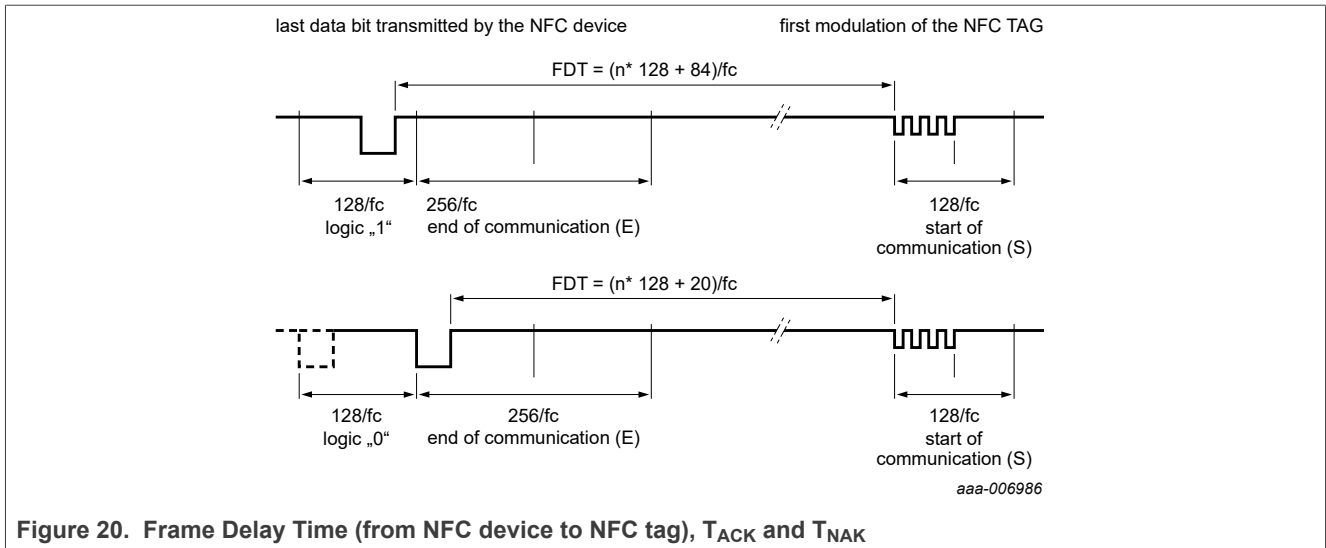

Remark: Due to the coding of commands, the measured timings usually exclude (a part of) the end of communication. Consider this factor when comparing the specified with the measured times.

10.3 NTAG ACK and NAK

NTAG I²C plus uses a 4-bit ACK / NAK as shown in [Table 17](#).

Table 17. ACK and NAK values

Code (4 bit)	ACK/NAK
Ah	Acknowledge (ACK)
0h	NAK for invalid argument (i.e. invalid page address or wrong password)
1h	NAK for parity or CRC error
3h	NAK for Arbiter locked to I ² C
4h	Number of negative PWD_AUTH commands limit reached
7h	NAK for EEPROM write error

10.4 ATQA and SAK responses

NTAG I²C plus replies to a REQA or WUPA command with the ATQA value shown below. It replies to a Select CL2 command with the SAK value shown below. The 2 byte ATQA value is transmitted with the least significant byte first (44h).

Table 18. ATQA response of the NTAG I²C plus

Sales type	Hex value	Bit number															
		15	14	13	12	11	10	9	8	7	6	5	4	3	2	1	0
NTAG I ² C plus	00 44h	0	0	0	0	0	0	0	0	0	1	0	0	0	1	0	0

Table 19. SAK response of the NTAG I²C plus

Sales type	Hex value	Bit number							
		7	6	5	4	3	2	1	0
NTAG I ² C plus	00h	0	0	0	0	0	0	0	0

Remark: The ATQA coding in bits 7 and 6 indicates the UID size according to [ISO/IEC 14443](#).

Remark: The bit numbering in ISO/IEC 14443 specification starts with bit 1 as least significant bit.

10.5 GET_VERSION

The GET_VERSION command is used to retrieve information about the NTAG family, the product version, storage size and other product data required to identify the specific NTAG I²C plus.

This command is also available on other NTAG products to have a common way of identifying products across platforms and evolution steps.

The GET_VERSION command has no arguments and returns the version information for the specific NTAG I²C plus type. The command structure is shown in [Figure 21](#) and [Table 20](#).

[Table 21](#) shows the required timing.

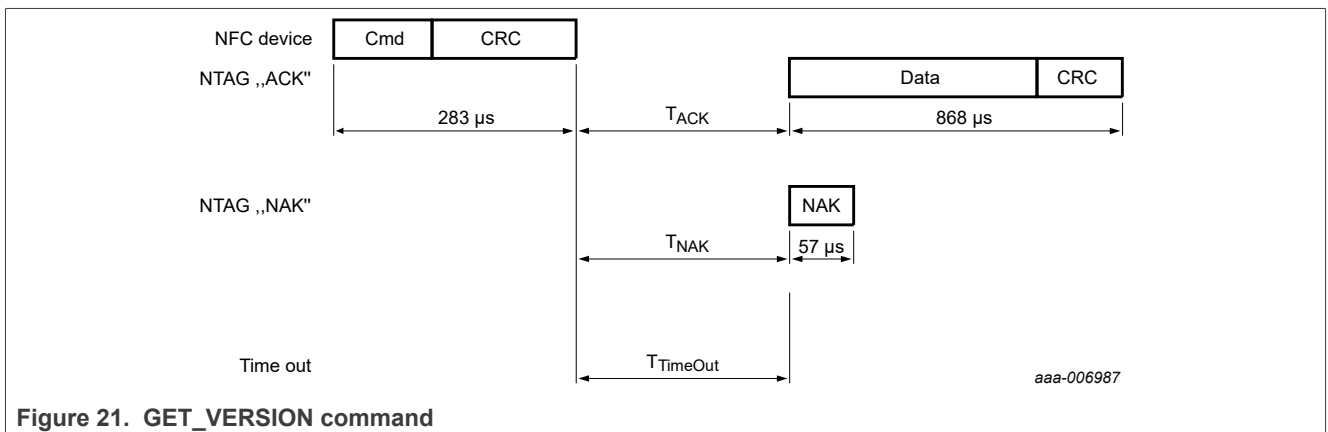

Figure 21. GET_VERSION command

Table 20. GET_VERSION command

Name	Code	Description	Length
Cmd	60h	Get product version	1 byte
CRC	-	CRC according to ISO/IEC 14443	2 bytes
Data	-	Product version information	8 bytes
NAK	see Table 17	see Section 10.3	4 bit

Table 21. GET_VERSION timing

These times exclude the end of communication of the NFC device.

	T _{ACK/NAK} min	T _{ACK/NAK} max	T _{TimeOut}
GET_VERSION	n=9 ^[1]	T _{TimeOut}	5 ms

[1] Refer to [Section 10.2](#).

Table 22. GET_VERSION response

Byte no.	Description	NTAG I ² C plus 512	NTAG I ² C plus 1k	NTAG I ² C plus 2k	Interpretation
0	fixed Header	00h	00h	00h	
1	vendor ID	04h	04h	04h	NXP Semiconductors
2	product type	04h	04h	04h	NTAG
3	product subtype	05h	05h	05h	50 pF I ² C, Event detection
4	major product version	02h	02h	02h	
5	minor product version	02h	02h	02h	
6	storage size	12h	13h	15h	see following information
7	protocol type	03h	03h	03h	ISO/IEC 14443-3 compliant

The most significant 7 bits of the storage size byte are interpreted as an unsigned integer value n. As a result, it codes the total available user memory size as 2ⁿ. If the least significant bit is 0b, the user memory size is exactly 2ⁿ. If the least significant bit is 1b, the user memory size is between 2ⁿ and 2ⁿ⁺¹.

10.6 READ_SIG

The READ_SIG command returns an IC specific, 32-byte ECC signature, to verify NXP Semiconductors as the silicon vendor. The signature is programmed at chip production and cannot be changed afterwards. The command structure is shown in [Figure 24](#) and [Table 27](#).

[Table 28](#) shows the required timing.

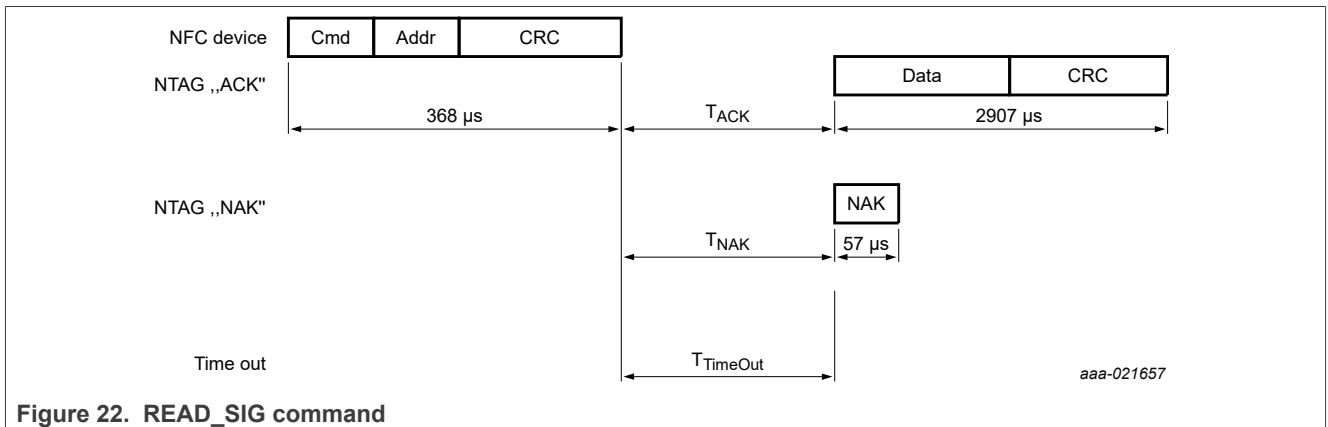

Table 23. READ_SIG command

Name	Code	Description	Length
Cmd	3Ch	read ECC signature	1 byte
Addr	00h	RFU, is set to 00h	1 byte
CRC	-	CRC according to ISO/IEC 14443	2 bytes
Signature	-	ECC Signature	32 bytes
NAK	see Table 17	see Section 10.3	4 bit

Table 24. READ_SIG timing

These times exclude the end of communication of the NFC device.

	T _{ACK/NAK min}	T _{ACK/NAK max}	T _{TimeOut}
READ_SIG	n=9 ^[1]	T _{TimeOut}	5 ms

[1] Refer to [Section 10.2 "Timing"](#).

Details on how to check the signature value are provided in the corresponding [application note](#). It is foreseen to offer an online and offline way to verify originality of NTAG I²C plus.

10.7 PWD_AUTH

A protected memory area can be accessed only after a successful password verification using the PWD_AUTH command. The AUTH0 configuration byte defines the start of the protected area. It specifies the first page that the password mechanism protects. The level of protection can be configured using the NFC_PROT bit either for write protection or read/write protection. The PWD_AUTH command takes the password as parameter and, if successful, returns the password authentication acknowledge, PACK. By setting the AUTHLIM configuration bits to a value larger than 000b, the number of unsuccessful password verifications can be limited. Each unsuccessful authentication is then counted. After reaching the limit (2^{AUTHLIM}) of unsuccessful attempts, the memory write access or the memory access at all (specified in NFC_PROT) to the protected area, is no longer possible. The PWD_AUTH command is shown in [Figure 23](#) and [Table 25](#).

[Table 26](#) shows the required timing.

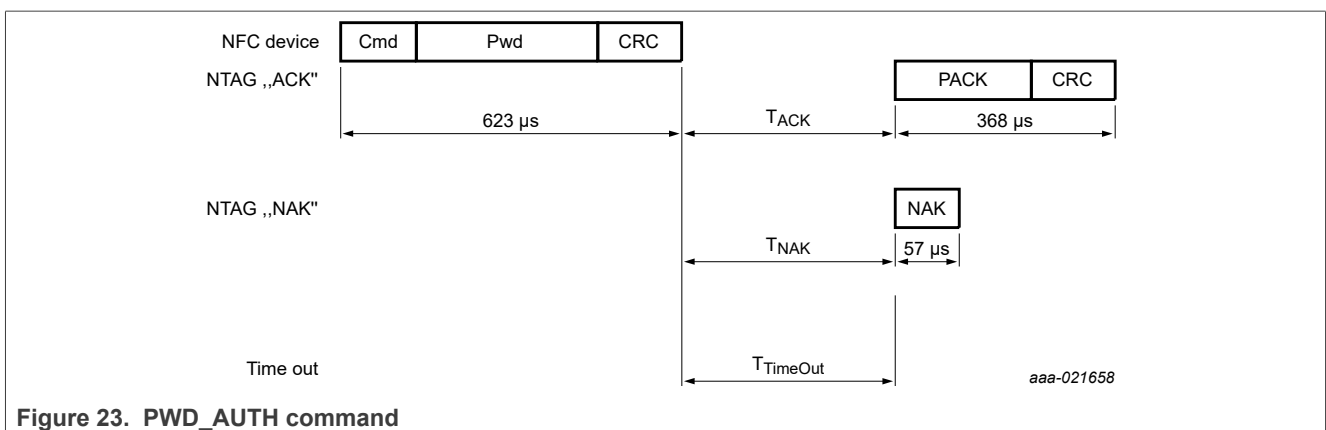

Figure 23. PWD_AUTH command

Table 25. PWD_AUTH command

Name	Code	Description	Length
Cmd	1Bh	password authentication	1 byte
Pwd	-	password	4 bytes
CRC	-	CRC according to ISO/IEC 14443	2 bytes
PACK	-	password authentication acknowledge	2 bytes
NAK	see Table 17	see Section 10.3	4-bit

Table 26. PWD_AUTH timing

These times exclude the end of communication of the NFC device.

	T _{ACK/NAK min}	T _{ACK/NAK max}	T _{TimeOut}
PWD_AUTH	n=9 ^[1]	T _{TimeOut}	5 ms

[1] Refer to [Section 10.2](#).

Remark: It is strongly recommended to change - and diversify for each tag - the password and PACK from its delivery state at tag issuing.

10.8 READ

The READ command requires a start page address, and returns the 16 bytes of four NTAG I²C plus pages. For example, if address (Addr) is 03h then pages 03h, 04h, 05h, 06h are returned. Special conditions apply if the READ command address is near the end of the accessible memory area. For details on those cases and the command structure, refer to [Figure 24](#) and [Table 27](#).

[Table 28](#) shows the required timing.

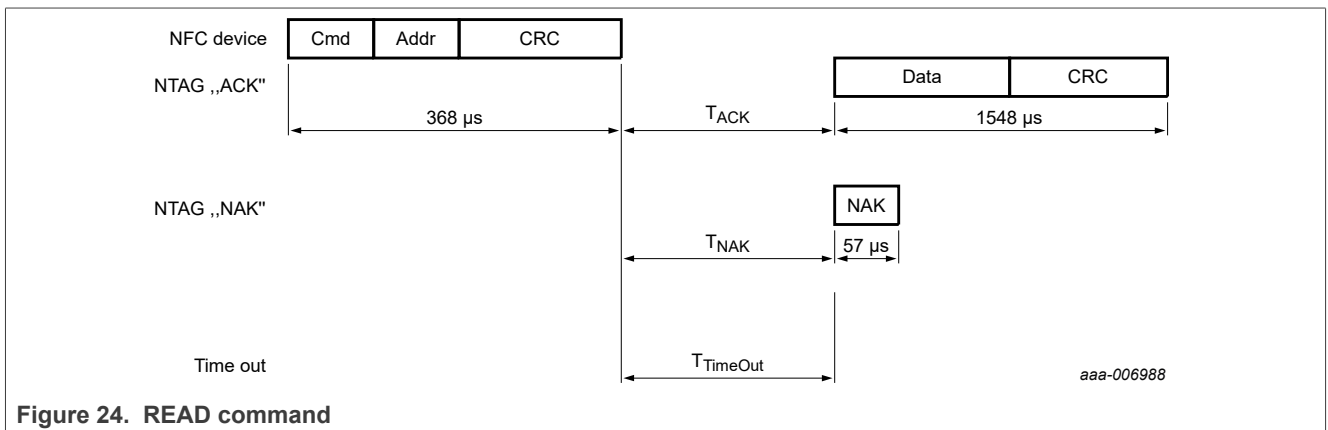

Figure 24. READ command

Table 27. READ command

Name	Code	Description	Length
Cmd	30h	read four pages	1 byte
Addr	-	start page address	1 byte
CRC	-	CRC according to ISO/IEC 14443	2 bytes

Table 27. READ command...continued

Name	Code	Description	Length
Data	-	Data content of the addressed pages	16 bytes
NAK	see Table 17	see Section 10.3	4 bit

Table 28. READ timing

These times exclude the end of communication of the NFC device.

	T _{ACK/NAK min}	T _{ACK/NAK max}	T _{TimeOut}
READ	n=9 ^[1]	T _{TimeOut}	5 ms

[1] Refer to [Section 10.2](#).

In the initial state of NTAG I²C plus, all memory pages are allowed as Addr parameter to the READ command:

- Page address from 00h to E9h and pages ECh and EDh for NTAG I²C plus 1k and 2k
- Page address from 00h to FFh (Sector 1) for NTAG I²C plus 2k only
- SRAM buffer address when pass-through mode is enabled

Addressing a start memory page beyond the limits above results in a NAK response from NTAG I²C plus.

In case a READ command addressing start with a valid memory area but extends over an invalid memory area, the content of the invalid memory area will be reported as 00h.

10.9 FAST_READ

The FAST_READ command requires a start page address and an end page address and returns all n*4 bytes of the addressed pages. For example, if the start address is 03h and the end address is 07h, then pages 03h, 04h, 05h, 06h and 07h are returned.

For details on those cases and the command structure, refer to [Figure 25](#) and [Table 29](#).

[Table 30](#) shows the required timing.

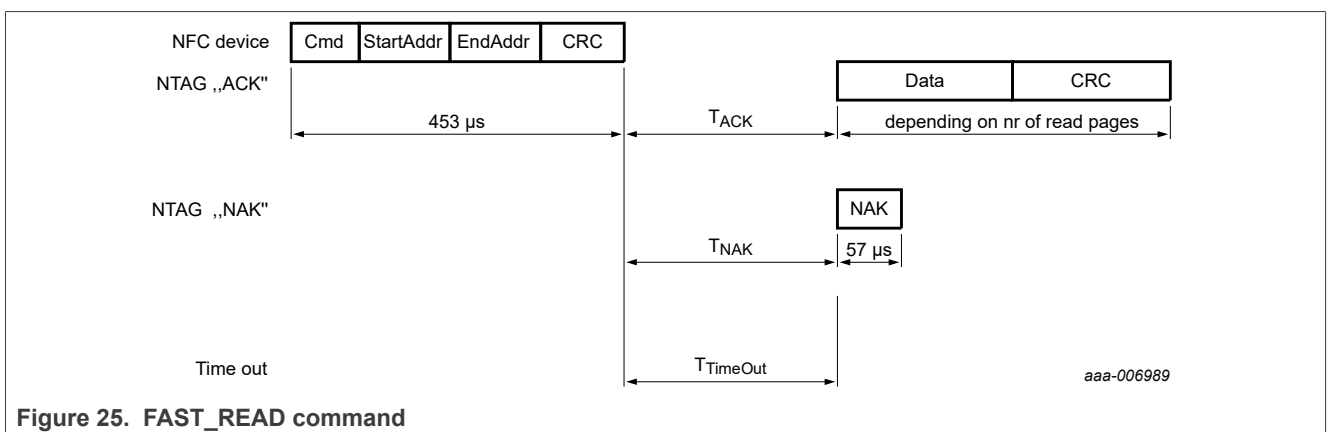

Figure 25. FAST_READ command

Table 29. FAST_READ command

Name	Code	Description	Length
Cmd	3Ah	read multiple pages	1 byte

Table 29. FAST_READ command...continued

Name	Code	Description	Length
StartAddr	-	start page address	1 byte
EndAddr	-	end page address	1 byte
CRC	-	CRC according to ISO/IEC 14443	2 bytes
Data	-	data content of the addressed pages	n*4 bytes
NAK	see Table 17	see Section 10.3	4 bit

Table 30. FAST_READ timing

These times exclude the end of communication of the NFC device.

	T _{ACK/NAK min}	T _{ACK/NAK max}	T _{TimeOut}
FAST_READ	n=9 ^[1]	T _{TimeOut}	5 ms

[1] Refer to [Section 10.2](#).

In the initial state of NTAG I²C *plus*, all memory pages are allowed as StartAddr parameter to the FAST_READ command:

- Page address from 00h to E9h and pages ECh and EDh for NTAG I²C *plus* 1k and 2k
- Page address from 00h to FFh (Sector 1) for NTAG I²C *plus* 2k only
- SRAM buffer address when pass-through mode is enabled

If the start addressed memory page (StartAddr) is outside of accessible area, NTAG I²C *plus* replies a NAK.

In case the FAST_READ command starts with a valid memory area but extends over an invalid memory area, the content of the invalid memory area will be reported as 00h.

The EndAddr parameter must be equal to or higher than the StartAddr.

Remark: The FAST_READ command is able to read out the entire memory of one sector with one command. Nevertheless, the receive buffer of the NFC device must be able to handle the requested amount of data as no chaining is possible.

10.10 WRITE

The WRITE command requires a page address, and writes 4 bytes of data into the addressed NTAG I²C *plus* page. The WRITE command is shown in [Figure 26](#) and [Table 31](#).

[Table 32](#) shows the required timing.

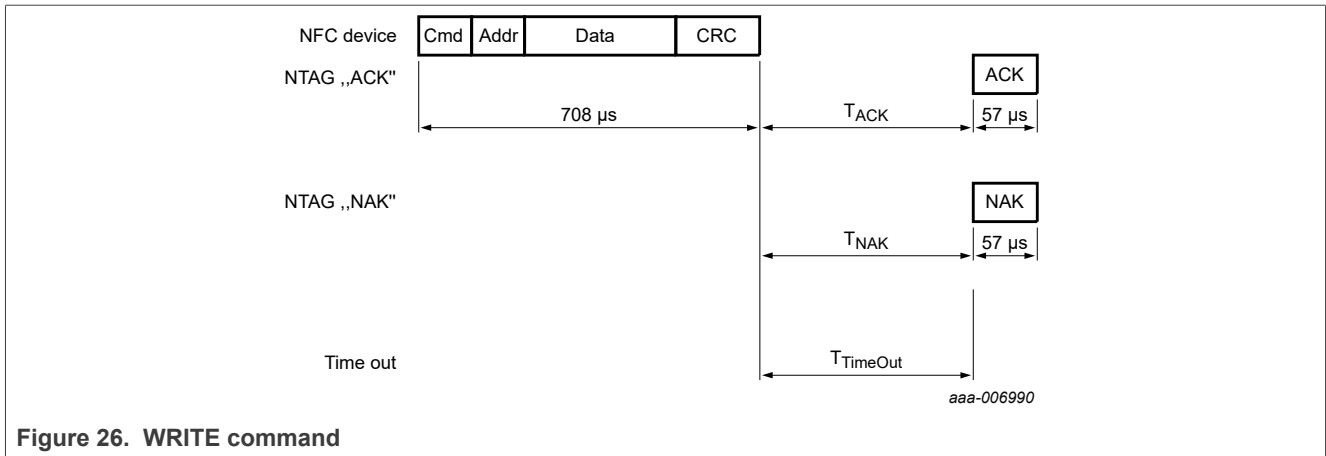

Table 31. WRITE command

Name	Code	Description	Length
Cmd	A2h	write one page	1 byte
Addr	-	page address	1 byte
Data	-	data	4 bytes
CRC	-	CRC according to ISO/IEC 14443	2 bytes
NAK	see Table 17	see Section 10.3	4 bit

Table 32. WRITE timing

These times exclude the end of communication of the NFC device.

	T _{ACK/NAK min}	T _{ACK/NAK max}	T _{TimeOut}
WRITE	n=9 ^[1]	T _{TimeOut}	5 ms

[1] Refer to [Section 10.2](#).

In the initial state of NTAG I²C plus, the following memory pages are valid Addr parameters to the WRITE command:

- Page address from 02h to E9h (Sector 0) for NTAG I²C plus 1k and 2k
- Page address from 00h to FFh (Sector 1) for NTAG I²C plus 2k
- SRAM buffer addresses when pass-through mode is enabled

Addressing a memory page beyond the limits above results in a NAK response from NTAG I²C plus.

Pages that are locked against writing cannot be reprogrammed using any write command. The locking mechanisms include static and dynamic lock bits, as well as the locking of the configuration pages.

10.11 FAST_WRITE

The FAST_WRITE allows writing data in ACTIVE state to the complete SRAM (64 bytes) in pass-through mode. It requires the start block address (F0h), end address (FFh) and writes 64 bytes of data into the NTAG I²C plus SRAM. The FAST_WRITE command is shown in [Figure 27](#) and [Table 33](#).

WARNING: Data is written directly to SRAM. If received CRC at the end of transmission is wrong and response was a NAK, received (corrupted) data is still in SRAM. Hence it is recommended to implement a protocol on top to ensure data integrity (e.g. include own CRC at the end of the payload) when using SRAM.

Table 34 shows the required timing.

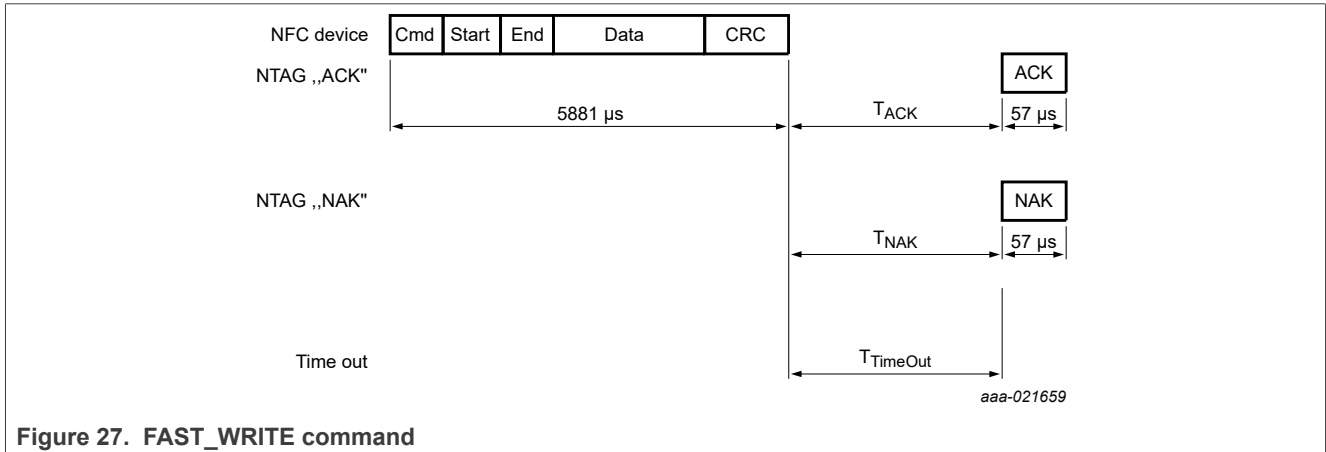

Figure 27. FAST_WRITE command

Table 33. FAST_WRITE command

Name	Code	Description	Length
Cmd	A6h	write complete SRAM	1 byte
START_ADDR	F0h	start SRAM in pass-through mode	1 byte
END_ADDR	FFh	end SRAM in pass-through mode	1 byte
Data	-	data	64 bytes
-	CRC	CRC according to ISO/IEC 14443	2 bytes
ACK	see Table 17	see Section 10.3	4 bit
NAK	see Table 17	see Section 10.3	4 bit

Table 34. FAST_WRITE timing

These times exclude the end of communication of the NFC device.

	T _{ACK/NAK} min	T _{ACK/NAK} max	T _{TimeOut}
FAST_WRITE	n=9 ^[1]	T _{TimeOut}	5 ms

[1] Refer to [Section 10.2](#).

10.12 SECTOR SELECT

The SECTOR SELECT command consists of two commands packet: the first one is the SECTOR SELECT command (C2h), FFh and CRC. Upon an ACK answer from the Tag, the second command packet needs to be issued with the related sector address to be accessed and 3 bytes RFU.

To successfully access to the requested memory sector, the tag shall issue a passive ACK, which is sending NO REPLY for more than 1 ms after the CRC of the second command set.

The SECTOR SELECT command is shown in [Figure 28](#) and [Table 35](#).

Table 36 shows the required timing.

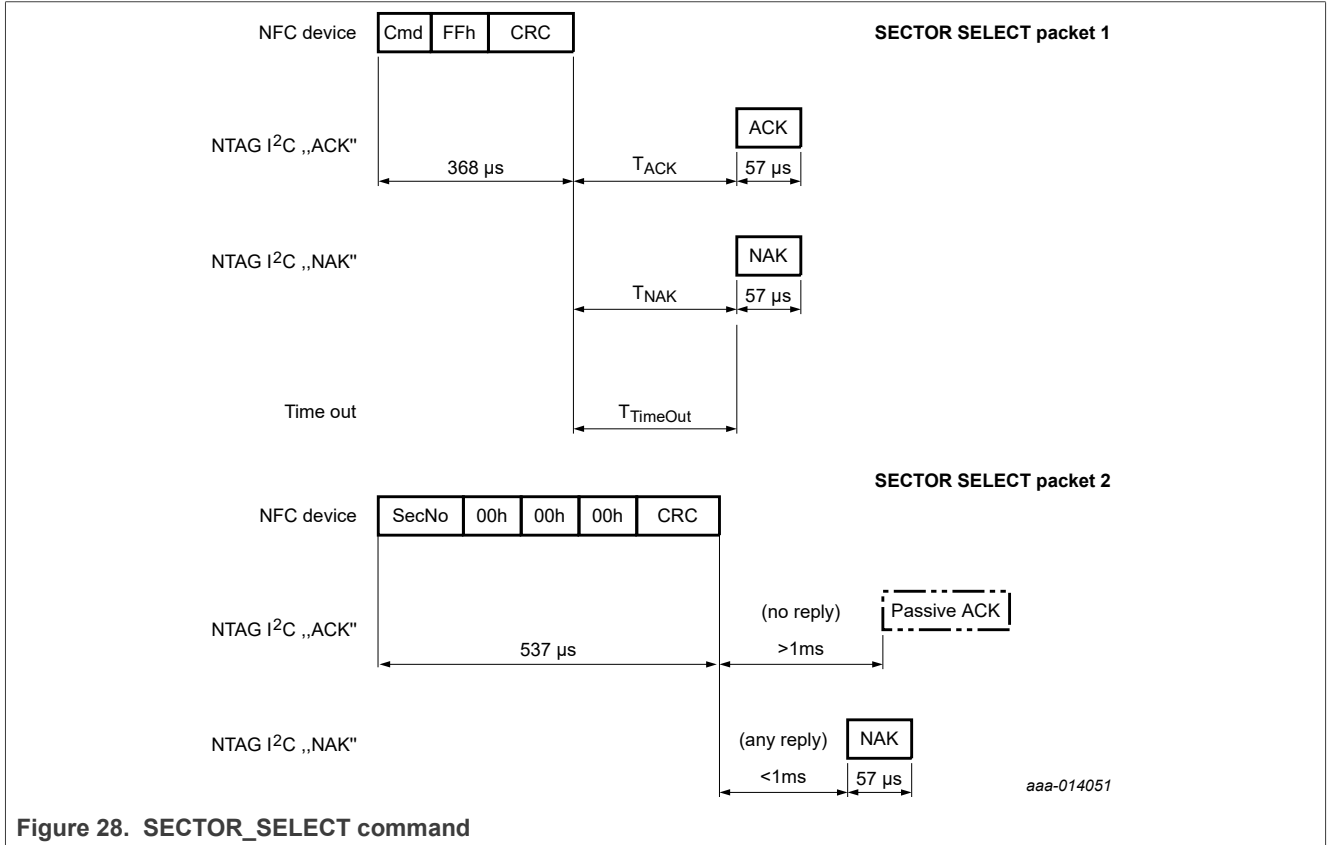

Table 35. SECTOR_SELECT command

Name	Code	Description	Length
Cmd	C2h	sector select	1 byte
FFh	-		1 byte
CRC	-	CRC according to ISO/IEC 14443	2 bytes
SecNo	-	Memory sector to be selected (00h - FEh)	1 byte
NAK	see Table 17	see Section 10.3	4 bit

Table 36. SECTOR_SELECT timing

These times exclude the end of communication of the NFC device.

	T _{ACK/NAK} min	T _{ACK/NAK} max	T _{TimeOut}
SECTOR_SELECT	n=9 ^[1]	T _{TimeOut}	5 ms

[1] Refer to [Section 10.2 "Timing"](#).

11 Communication and arbitration between NFC and I²C interface

If both interfaces are powered by their corresponding source, only one interface shall have access to the memory according to the "first-come, first-serve" principle.

In NS_REG, the two status bits I2C_LOCKED and RF_LOCKED reflect the status of the NTAG I²C *plus* memory access and indicate which interface is locking the memory access. At power-on, both bits are 0b, setting the arbitration in idle mode.

In the case arbiter locks to the I²C interface, an NFC device can still read the session registers. If the NFC state machine is in ACTIVE state, only the SECTOR SELECT command is allowed. But any other command requiring EEPROM access like READ or WRITE is handled as an illegal command and replied to with a NAK value.

In the case where the memory access is locked to the NFC interface, the I²C host can still access the session register, by issuing a 'Register READ/WRITE' command. All other read or write commands will be replied to with a NACK to the I²C host.

11.1 Pass-through mode not activated

PTHRU_ON_OFF = 0b (see [Table 13](#)) indicates non-pass-through mode.

11.1.1 I²C interface access

If the tag is in the IDLE or HALT state (NFC state after POR or HALT-command) and the correct I²C slave address of NTAG I²C *plus* is received following the START condition, the bit I2C_LOCKED will be automatically set to 1b. If I2C_LOCKED = 1b, the I²C interface has access to the tag memory and the tag will respond with a NACK to any memory READ/WRITE command on the NFC interface other than reading the session register bytes during this time.

I2C_LOCKED must be either reset to 0b at the end of the I²C sequence or will be cleared automatically after the end of the watchdog timer.

11.1.2 NFC interface access

The arbitration allows the NFC interface read and write accesses to EEPROM only when I2C_LOCKED is set to 0b.

RF_LOCKED is automatically set to 1b if the tag receives a valid command (EEPROM access commands) on the NFC interface. If RF_LOCKED = 1b, the tag is locked to the NFC interface and will not respond to any command from the I²C interface other than READ register command (see [Table 13](#)).

RF_LOCKED is automatically set to 0b in one of the following conditions:

- At POR or if the NFC field is switched off
- If the tag is set to the HALT state with a HALT command on the NFC interface
- If the memory access command is finished on the NFC interface

When the NFC interface has read the last page of the NDEF message specified in LAST_NDEF_BLOCK (see [Table 11](#) and [Table 12](#)) the bit NDEF_DATA_READ - in the register NS_REG see [Table 13](#) - is set to 1b and indicates to the I²C interface that, for example, new NDEF data can be written.

11.2 SRAM buffer mapping with Memory Mirror enabled

With SRAM_MIRROR_ON_OFF= 1b, the SRAM buffer mirroring is enabled. This mode cannot be combined with the pass-through mode (see [Section 11.3](#)).

NTAG I²C plus: NFC Forum T2T with I²C interface, password protection and energy harvesting

With the memory mirror enabled, the SRAM is now mapped into the user memory from the NFC interface perspective using the SRAM mirror lower page address specified in SRAM_MIRROR_BLOCK byte (Table 11 and Table 12). See Table 37 (NTAG I²C plus 1k) and Table 38 (NTAG I²C plus 2k) for an illustration of this SRAM memory mapping when SRAM_MIRROR_BLOCK is set to 01h.

Password protection to this mapped SRAM may be enabled by enabling password authentication and setting SRAM_PROT bit to 1b.

In contrary to password protection, for read only locking there are no special lock bits for the SRAM. Whenever user EEPROM blocks are locked to read-only with static and/or dynamic lock bits, potential mirrored SRAM blocks are read-only, too.

The tag must be VCC powered to make this mode work, because without VCC, the SRAM will not be accessible via NFC powered only.

When mapping the SRAM buffer to the user memory, the user shall be aware that all data written into the SRAM will be lost once the NTAG I²C plus is no longer powered from the I²C side (as SRAM is a volatile memory).

Table 37. Illustration of the SRAM memory addressing via the NFC interface (with SRAM_MIRROR_ON_OFF set to 1b and SRAM_MIRROR_BLOCK set to 01h) for the NTAG I²C plus 1k

Sector address	Page address		Byte number within a page				Access cond. ACTIVE state	Access cond. AUTH. state
	Dec.	Hex.	0	1	2	3		
0	0	00h	Serial number (UID)				READ	
	1	01h	Serial number (UID)			Internal	READ	
	2	02h	Internal		Static lock bytes		READ/R&W	
	3	03h	Capability Container (CC)				READ&WRITE	
	4	04h	SRAM				READ&WRITE	
						
	19	13h						
	Unprotected user memory				READ&WRITE	
	AUTH0	AUTH0	Protected user memory				READ	READ&WRITE
						
	225	E1h						
	226	E2h	Dynamic lock bytes			00h	R&W/READ	
	227	E3h	RFU	RFU	RFU	AUTH0	READ	READ&WRITE
	228	E4h	ACCESS	RFU	RFU	RFU	READ	READ&WRITE
	229	E5h	PWD				READ	READ&WRITE
	230	E6h	PACK		RFU	RFU	READ	READ&WRITE
	231	E7h	PT_I2C	RFU	RFU	RFU	READ	READ&WRITE
	232	E8h	Configuration registers				see Table 11	
	233	E9h						
234	EAh	Invalid access - returns NAK				n.a.		
235	EBh							
236	ECh	Session registers				see Table 12		
237	EDh							

NTAG I²C plus: NFC Forum T2T with I²C interface, password protection and energy harvesting

Table 37. Illustration of the SRAM memory addressing via the NFC interface (with SRAM_MIRROR_ON_OFF set to 1b and SRAM_MIRROR_BLOCK set to 01h) for the NTAG I²C plus 1k...continued

Sector address	Page address		Byte number within a page				Access cond. ACTIVE state	Access cond. AUTH. state
	Dec.	Hex.	0	1	2	3		
	238	EEh	Invalid access - returns NAK				n.a.	
	239	EFh						
	240	F0h	Invalid access - returns NAK				n.a.	
						
	255	FFh						
1	Invalid access - returns NAK				n.a.	
2	Invalid access - returns NAK				n.a.	
3	0	00h	Invalid access - returns NAK				n.a.	
						
	248	F8h	Session registers				see Table 12	
	249	F9h						
	Invalid access - returns NAK				n.a.	
255	FFh							

Table 38. Illustration of the SRAM memory addressing via the NFC interface (with SRAM_MIRROR_ON_OFF set to 1b and SRAM_MIRROR_BLOCK set to 01h) for the NTAG I²C plus 2k

Sector address	Page address		Byte number within a page				Access cond. ACTIVE state	Access cond. AUTH. state
	Dec.	Hex.	0	1	2	3		
0	0	00h	Serial number (UID)				READ	
	1	01h	Serial number (UID)			Internal	READ	
	2	02h	Internal		Static lock bytes		READ/R&W	
	3	03h	Capability Container (CC)				READ&WRITE	
	4	04h	SRAM				READ&WRITE	
						
	19	13h						
	Unprotected user memory				READ&WRITE	
	AUTH0	AUTH0	Protected user memory				READ	READ&WRITE
						
	225	E1h						
	226	E2h	Dynamic lock bytes			00h	R&W/READ	
	227	E3h	RFU	RFU	RFU	AUTH0	READ	READ&WRITE
	228	E4h	ACCESS	RFU	RFU	RFU	READ	READ&WRITE
	229	E5h	PWD				READ	READ&WRITE
230	E6h	PACK		RFU	RFU	READ	READ&WRITE	

Table 38. Illustration of the SRAM memory addressing via the NFC interface (with SRAM_MIRROR_ON_OFF set to 1b and SRAM_MIRROR_BLOCK set to 01h) for the NTAG I²C plus 2k...continued

Sector address	Page address		Byte number within a page				Access cond. ACTIVE state	Access cond. AUTH. state
	Dec.	Hex.	0	1	2	3		
	231	E7h	PT_I2C	RFU	RFU	RFU	READ	READ&WRITE
	232	E8h	Configuration registers				see Table 11	
	233	E9h						
	234	EAh	Invalid access - returns NAK				n.a.	
	235	EBh						
	236	ECh	Session registers				see Table 12	
	237	EDh						
	238	EEh	Invalid access - returns NAK				n.a.	
	239	EFh						
	240	F0h	Invalid access - returns NAK				n.a.	
						
255	FFh							
1	0	00h	(Un-)protected user memory				READ&WRITE	
						
	255	FFh						
2	Invalid access - returns NAK				n.a.	
3	0	00h	Invalid access - returns NAK				n.a.	
						
	248	F8h	Session registers				see Table 12	
	249	F9h						
	Invalid access - returns NAK				n.a.	
255	FFh							

11.3 Pass-through mode

PTHRU_ON_OFF = 1b (see [Table 13](#)) enables and indicates pass-through mode.

Password protection for pass-through mode may be enabled by enabling password authentication and setting SRAM_PROT bit to 1b.

To handle large amount of data transfer from one interface to the other, NTAG I²C plus offers the pass-through mode where data is transferred via a 64 byte SRAM. This buffer offers fast write access and unlimited write endurance as well as an easy handshake mechanism between the two interfaces.

This buffer is mapped directly at the end of the Sector 0 of NTAG I²C plus.

In both directions, the principle of access to the SRAM buffer via the NFC and I²C interface is exactly the same (see [Section 11.3.2](#) and [Section 11.3.3](#)).

The data flow direction must be set with the TRANSFER_DIR bit (see [Table 14](#)) within the current communication session using the session registers (it can only be set via the I²C interfaces) or for the

configuration bits after POR (in this case both NFC and I²C interface can set it). This pass-through direction setting avoids locking the memory access during the data transfer from one interface to the SRAM buffer.

The pass-through mode can only be enabled via I²C interface when both interfaces are powered. The PTHRU_ON_OFF bit, located in the session registers NC_REG (see [Table 14](#)), needs to be set to 1b. In case one interface powers off, the pass-through mode is disabled automatically.

NTAG I²C plus introduces in addition to the FAST_READ command a FAST_WRITE command. With this new command in ACTIVE state whole SRAM can be written at once, which improves the total pass-through performance significantly.

For more information read related [application note](#).

11.3.1 SRAM buffer mapping

In pass-through mode, the SRAM of NTAG I²C plus is mirrored to pages F0h to FFh of Sector 0.

The last page/block of the SRAM (page FFh) is used as the terminator page. Once the terminator page/block in the respective interfaces is read/written, the control would be transferred to other interface (NFC/I²C) - see [Section 11.3.2](#) and [Section 11.3.3](#) for more details.

Accordingly, the application can align on the reader and host side to transfer 16/32/48/64 bytes of data in one pass-through step by only using the last blocks/page of the SRAM buffer.

For best performance in addition to the FAST_READ, the FAST_WRITE command should be used.

Table 39. Illustration of the SRAM memory addressing via the NFC interface in pass-through mode (PTHRU_ON_OFF set to 1b) for the NTAG I²C plus 1k

Sector address	Page address		Byte number within a page				Access cond. ACTIVE state	Access cond. AUTH. state
	Dec.	Hex.	0	1	2	3		
0	0	00h	Serial number (UID)				READ	
	1	01h	Serial number (UID)			Internal	READ	
	2	02h	Internal		Static lock bytes		READ/R&W	
	3	03h	Capability Container (CC)				READ&WRITE	
	4	04h	Unprotected user memory				READ&WRITE	
						
	AUTH0	AUTH0						
	Protected user memory				READ	READ&WRITE
	225	E1h						
	226	E2h	Dynamic lock bytes			00h	R&W/READ	
	227	E3h	RFU	RFU	RFU	AUTH0	READ	READ&WRITE
	228	E4h	ACCESS	RFU	RFU	RFU	READ	READ&WRITE
	229	E5h	PWD				READ	READ&WRITE
	230	E6h	PACK		RFU	RFU	READ	READ&WRITE
	231	E7h	PT_I2C	RFU	RFU	RFU	READ	READ&WRITE
232	E8h	Configuration registers				see Table 11		
233	E9h							
234	EAh	Invalid access - returns NAK				n.a.		

NTAG I²C plus: NFC Forum T2T with I²C interface, password protection and energy harvesting

Table 39. Illustration of the SRAM memory addressing via the NFC interface in pass-through mode (PTHRU_ON_OFF set to 1b) for the NTAG I²C plus 1k...continued

Sector address	Page address		Byte number within a page				Access cond. ACTIVE state	Access cond. AUTH. state
	Dec.	Hex.	0	1	2	3		
	235	EBh					see Table 12	
	236	ECh	Session registers					
	237	EDh						
	238	EEh	Invalid access - returns NAK				n.a.	
	239	EFh						
	240	F0h	SRAM				READ&WRITE	
						
255	FFh							
1	Invalid access - returns NAK				n.a.	
2	Invalid access - returns NAK				n.a.	
3	0	00h	Invalid access - returns NAK				n.a.	
						
	248	F8h	Session registers				see Table 12	
	249	F9h						
	Invalid access - returns NAK				n.a.	
255	FFh							

Table 40. Illustration of the SRAM memory addressing via the NFC interface in pass-through mode (PTHRU_ON_OFF set to 1b) for the NTAG I²C plus 2k

Sector address	Page address		Byte number within a page				Access cond. ACTIVE state	Access cond. AUTH. state
	Dec.	Hex.	0	1	2	3		
0	0	00h	Serial number (UID)				READ	
	1	01h	Serial number (UID)			Internal	READ	
	2	02h	Internal		Static lock bytes		READ/R&W	
	3	03h	Capability Container (CC)				READ&WRITE	
	4	04h	Unprotected user memory				READ&WRITE	
						
	AUTH0	AUTH0						
						
	225	E1h						
	226	E2h	Dynamic lock bytes			00h	R&W/READ	
	227	E3h	RFU	RFU	RFU	AUTH0	READ	READ&WRITE
	228	E4h	ACCESS	RFU	RFU	RFU	READ	READ&WRITE
	229	E5h	PWD				READ	READ&WRITE

Table 40. Illustration of the SRAM memory addressing via the NFC interface in pass-through mode (PTHRU_ON_OFF set to 1b) for the NTAG I²C plus 2k...continued

Sector address	Page address		Byte number within a page				Access cond. ACTIVE state	Access cond. AUTH. state
	Dec.	Hex.	0	1	2	3		
	230	E6h	PACK		RFU	RFU	READ	READ&WRITE
	231	E7h	PT_I2C	RFU	RFU	RFU	READ	READ&WRITE
	232	E8h	Configuration registers				see Table 11	
	233	E9h						
	234	EAh	Invalid access - returns NAK				n.a.	
	235	EBh						
	236	ECh	Session registers				see Table 12	
	237	EDh						
	238	EEh	Invalid access - returns NAK				n.a.	
	239	EFh						
	240	F0h	SRAM				READ&WRITE	
						
255	FFh							
1	0	00h	(Un-)protected user memory				READ&WRITE	
						
	255	FFh						
2	Invalid access - returns NAK				n.a.	
3	0	00h	Invalid access - returns NAK				n.a.	
						
	248	F8h	Session registers				see Table 12	
	249	F9h						
	Invalid access - returns NAK				n.a.	
255	FFh							

11.3.2 NFC to I²C data transfer

If the NFC interface is enabled (RF_LOCKED = 1b) and data is written to the terminator page FFh of the SRAM via the NFC interface, at the end of the WRITE command, bit SRAM_I2C_READY is set to 1b and bit RF_LOCKED is set to 0b automatically, and the NTAG I²C plus is locked to the I²C interface.

To signal the host that data is ready to be read following mechanisms are in place:

- The host polls/reads bit SRAM_I2C_READY from NS_REG (see [Table 14](#)) to know if data is ready in SRAM
- A trigger on the FD pin indicates to the host that data is ready to be read from SRAM. This feature can be enabled by programming bits 5:2 (FD_OFF, FD_ON) of the NC_REG appropriately (see [Table 13](#))

This is illustrated in the [Figure 29](#).

If the tag is addressed with the correct I²C slave address, the I2C_LOCKED bit is automatically set to 1b (according to the interface arbitration). After a READ from the terminator page of the SRAM, bit

SRAM_I2C_READY and bit I2C_LOCKED are automatically reset to 0b. The tag returns to the arbitration idle mode where, for example, further data from the NFC interface can be transferred.

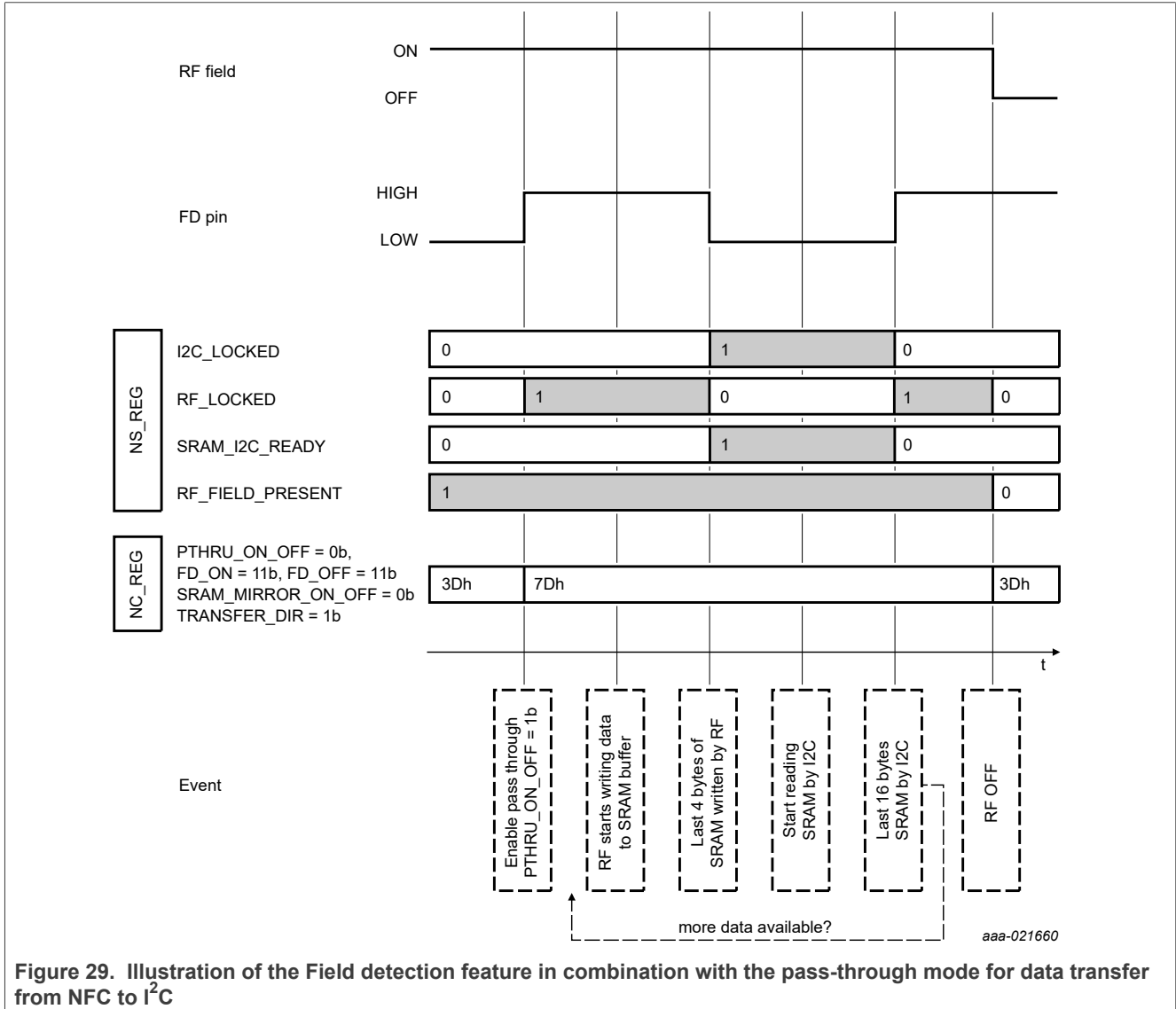

Figure 29. Illustration of the Field detection feature in combination with the pass-through mode for data transfer from NFC to I²C

11.3.3 I²C to NFC data transfer

If the I²C interface is enabled (I2C_LOCKED is 1b) and data is written to the terminator block FBh of the SRAM via the I²C interface, at the end of the WRITE command, bit SRAM_RF_READY is set to 1b and bit I2C_LOCKED is automatically reset to 0b to set the tag in the arbitration idle state.

The RF_LOCKED bit is then automatically set to 1b (according to the interface arbitration). After a READ or FAST_READ command involving the terminator page of the SRAM, bit SRAM_RF_READY and bit RF_LOCKED are automatically reset to 0b allowing the I²C interface to further write data into the SRAM buffer.

To signal to the host that further data is ready to be written, the following mechanisms are in place:

- The NFC interface polls/reads the bit SRAM_RF_READY from NS_REG (see Table 14) to know if new data has been written by the I²C interface in the SRAM

- A trigger on the FD pin indicates to the host that data has been read from SRAM by the NFC interface. This feature can be enabled by programming bits 5:2 (FD_OFF, FD_ON) of the NC_REG appropriately (see [Table 13](#))

The above mechanism is illustrated in the [Figure 30](#).

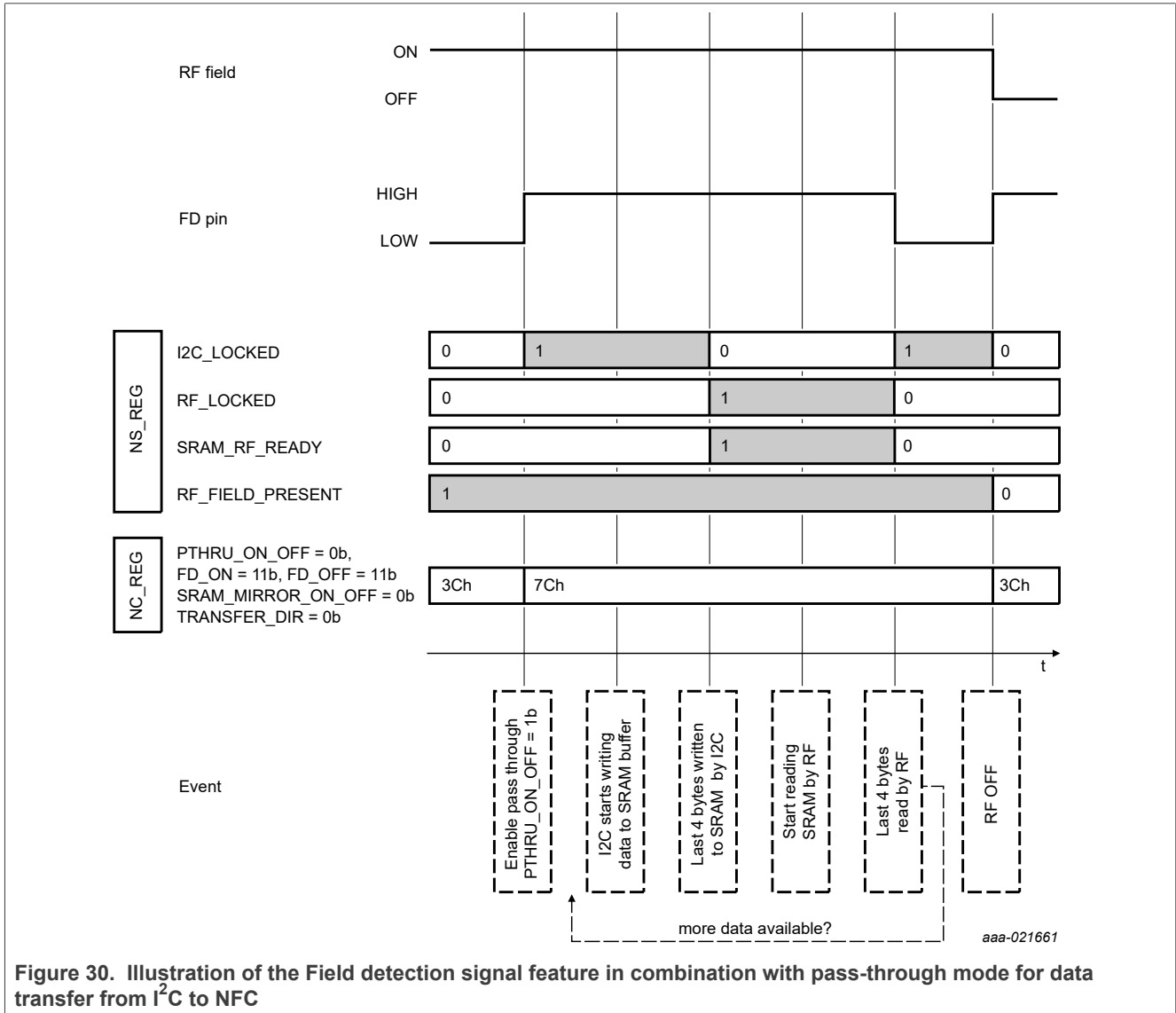

Figure 30. Illustration of the Field detection signal feature in combination with pass-through mode for data transfer from I²C to NFC

12 Limiting values

Exceeding the limits of one or more values in reference may cause permanent damage to the device. Exposure to limiting values for extended periods may affect device reliability.

Table 41. Limiting values

In accordance with the Absolute Maximum Rating System (IEC 60134). ^[1] ^[2]

Symbol	Parameter	Conditions	Min	Max	Unit
T _{stg}	storage temperature		-55	+125	°C
T _{j(max)}	maximum junction temperature		-	+105	°C
V _{ESD}	electrostatic discharge voltage	human body model (HBM) ^[3]	-	2	kV
		charge device model (CDM) ^[4]	-	1	kV
V _{DD}	supply voltage	on pin VCC	-0.5	4.6	V
V _i	input voltage	on pin FD, SDA, SCL	-0.5	4.6	V
I _i	input current	on pin LA, LB	-	40	mA
V _{i(RF)}	RF input voltage	on pin LA, LB	-	4.6	V _{peak}

[1] Stresses above one or more of the limiting values may cause permanent damage to the device.

[2] Exposure to limiting values for extended periods may affect device reliability.

[3] According to ANSI/ESDA/JEDEC JS-001.

[4] According to ANSI/ESDA/JEDEC JS-002.

13 Characteristics

13.1 Electrical characteristics

Table 42. Characteristics

Symbol	Parameter	Conditions	Min	Typ	Max	Unit
C _i	input capacitance	LA - LB, on-chip - C _{IC} , f=13.56 MHz, V _{LA-LB} =2.4 V _{RMS}	44	50	56	pF
f _i	input frequency		-	13.56	-	MHz
T _{amb}	operating ambient temperature		-40	25	+105 ^[1]	°C
R _{TH_JA}	thermal resistance	JEDEC 2s2p board and XQFN8 package	-	150	-	K/W
R _{TH_JA}	thermal resistance	JEDEC 2s2p board and TSSOP8 package	-	211	-	K/W
R _{TH_JA}	thermal resistance	JEDEC 2s2p board and SO8 package	-	115	-	K/W
Energy harvesting characteristics						
V _{out,max}	output voltage	generated at the V _{out} pin, Class 5 antenna, 14 A/m, load current 1 mA	^[2]	-	3.3	V
I²C interface characteristics						
V _{CC}	supply voltage	supplied via V _{CC} only	1.67	-	3.6	V
I _{DD}	supply current	V _{CC} =1.8 V I ² C; idle bus	-	160	-	μA
		V _{CC} =3.3 V I ² C; idle bus	-	195	-	μA
I _{DD}	supply current	V _{CC} =1.8 V I ² C@400KHz	-	-	185	μA
		V _{CC} =2.5 V I ² C@400KHz	-	-	210	μA
		V _{CC} =3.3 V I ² C@400KHz	-	-	240	μA
I²C pin characteristics						
V _{OL}	LOW-level output voltage	I _{OL} = 3 mA; V _{CC} > 2 V	-	-	0.4	V
		I _{OL} = 2 mA; V _{CC} < 2 V	-	-	0.2*V _{CC}	V
V _{IH}	HIGH-level input voltage		0.7*V _{CC}	-	-	V
V _{IL}	LOW-level input voltage		-	-	0.3*V _{CC}	V
C _i	input capacitance	SCL and SDA pin	-	2.4	-	pF
I _L	leakage current	0 V and V _{CC,max}	-	-	10	μA
t _{high}	SCL high time	fast mode 400 kHz	950	-	-	ns
FD pin characteristics						
V _{OL}	LOW-level output voltage	I _{OL} = 4 mA; V _{CC} > 2 V	-	-	0.4	V
		I _{OL} = 3 mA; V _{CC} < 2 V	-	-	0.2*V _{CC}	V
I _L	leakage current		-	1.5	10	μA
EEPROM characteristics						

Table 42. Characteristics...continued

Symbol	Parameter	Conditions	Min	Typ	Max	Unit
t _{ret}	retention time	T _{amb}	20	50	-	year
N _{endu(W)}	write endurance	T _{amb}	200000	-	-	cycle
N _{endu(W)}	write endurance	-40 °C to 95 °C	500000	1000000	-	cycle

[1] Dependent on PCB design and operating conditions

[2] Minimum value depends on available field strength and load current conditions. For details refer to energy harvesting [application note](#)

14 Package outline

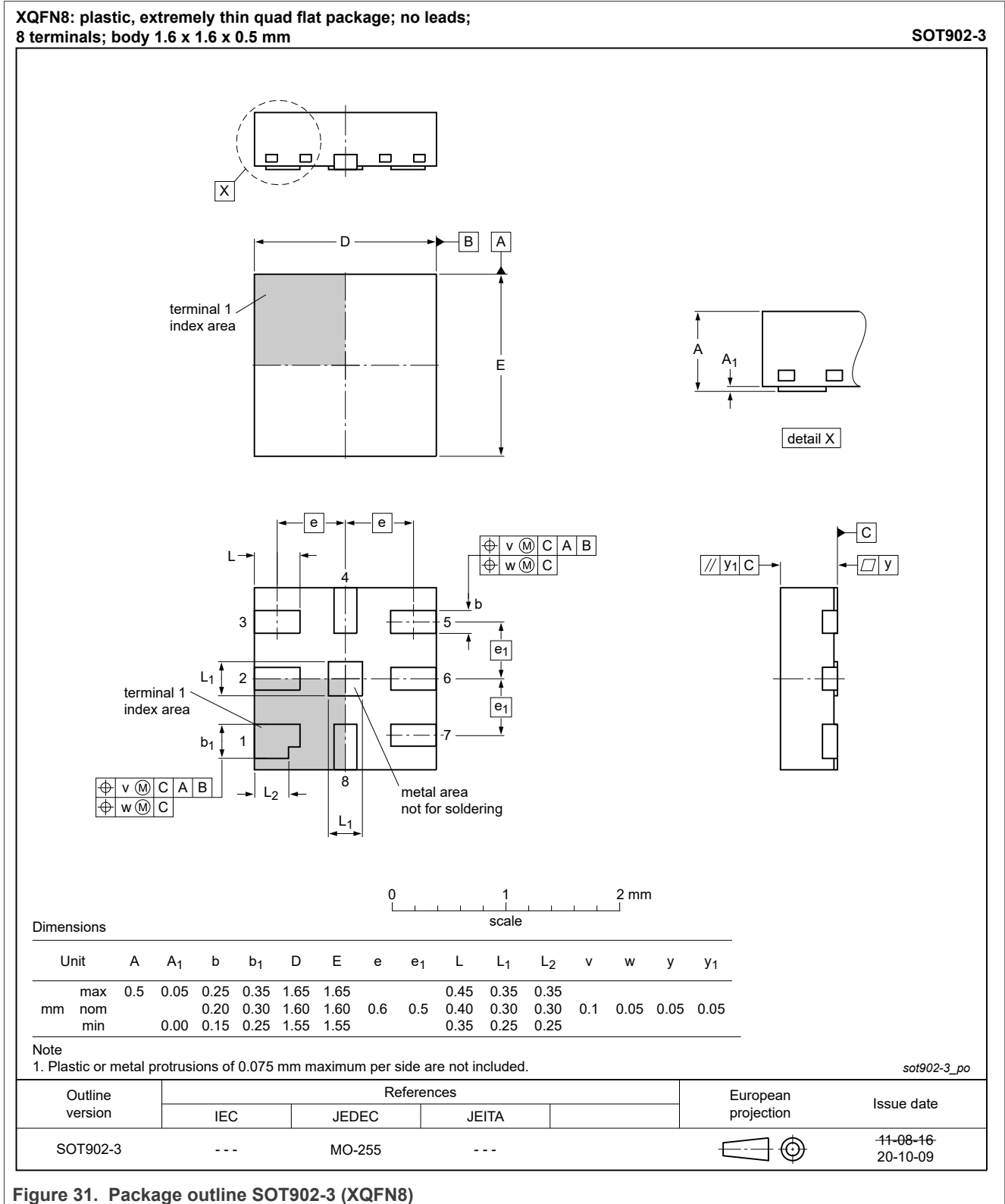

Figure 31. Package outline SOT902-3 (XQFN8)

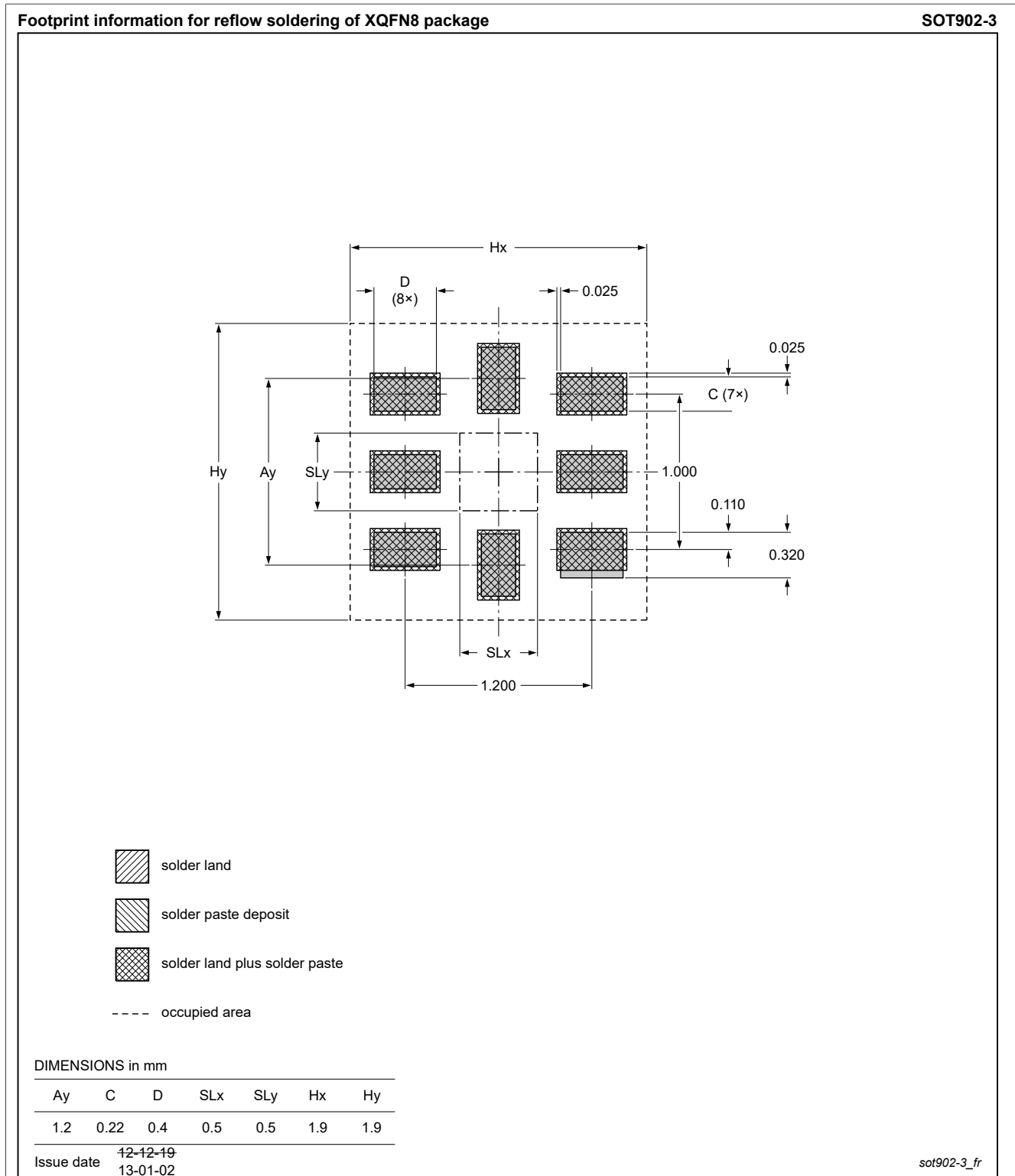
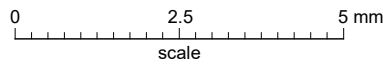
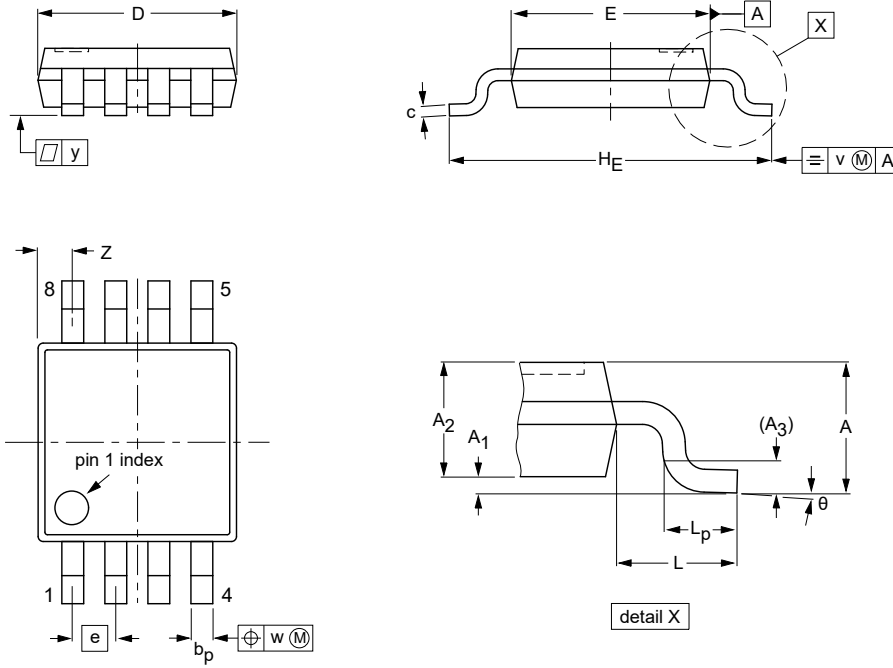

Figure 32. Footprint information for reflow soldering of XQFN8 package - SOT902-3

Find [here](#) detailed package and soldering information.

TSSOP8: plastic thin shrink small outline package; 8 leads; body width 3 mm

SOT505-1



DIMENSIONS (mm are the original dimensions)

UNIT	A max.	A ₁	A ₂	A ₃	b _p	c	D ⁽¹⁾	E ⁽²⁾	e	H _E	L	L _p	v	w	y	Z ⁽¹⁾	θ
mm	1.1	0.15 0.05	0.95 0.80	0.25	0.45 0.25	0.28 0.15	3.1 2.9	3.1 2.9	0.65	5.1 4.7	0.94	0.7 0.4	0.1	0.1	0.1	0.70 0.35	6° 0°

Notes

1. Plastic or metal protrusions of 0.15 mm maximum per side are not included.
2. Plastic or metal protrusions of 0.25 mm maximum per side are not included.

OUTLINE VERSION	REFERENCES				EUROPEAN PROJECTION	ISSUE DATE
	IEC	JEDEC	JEITA			
SOT505-1						99-04-09 03-02-18

Figure 33. Package outline SOT505-1 (TSSOP8)

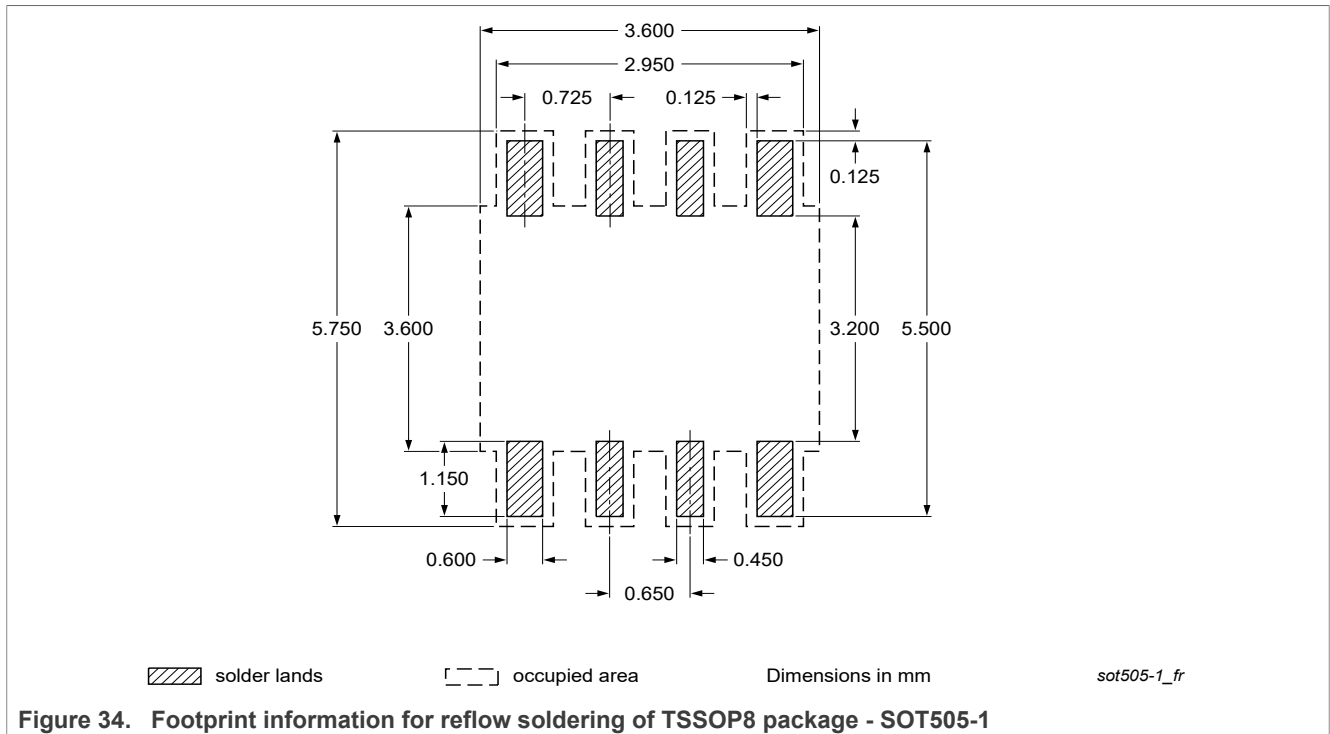

Find [here](#) detailed package and soldering information.

SO8: plastic small outline package; 8 leads; body width 3.9 mm

SOT96-1

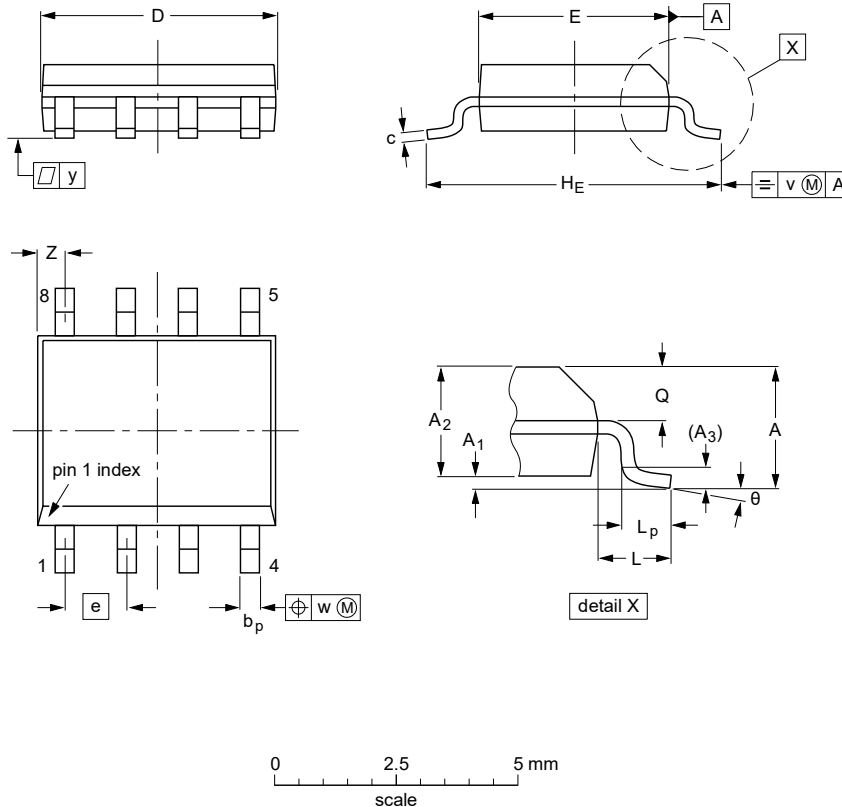

DIMENSIONS (inch dimensions are derived from the original mm dimensions)

UNIT	A max.	A ₁	A ₂	A ₃	b _p	c	D ⁽¹⁾	E ⁽²⁾	e	H _E	L	L _p	Q	v	w	y	Z ⁽¹⁾	θ
mm	1.75	0.25 0.10	1.45 1.25	0.25	0.49 0.36	0.25 0.19	5.0 4.8	4.0 3.8	1.27	6.2 5.8	1.05	1.0 0.4	0.7 0.6	0.25	0.25	0.1	0.7 0.3	8° 0°
inches	0.069	0.010 0.004	0.057 0.049	0.01	0.019 0.014	0.0100 0.0075	0.20 0.19	0.16 0.15	0.05	0.244 0.228	0.041	0.039 0.016	0.028 0.024	0.01	0.01	0.004	0.028 0.012	

Notes

1. Plastic or metal protrusions of 0.15 mm (0.006 inch) maximum per side are not included.
2. Plastic or metal protrusions of 0.25 mm (0.01 inch) maximum per side are not included.

OUTLINE VERSION	REFERENCES				EUROPEAN PROJECTION	ISSUE DATE
	IEC	JEDEC	JEITA			
SOT96-1	076E03	MS-012				99-12-27 03-02-18

Figure 35. Package outline SOT96-1 (SO8)

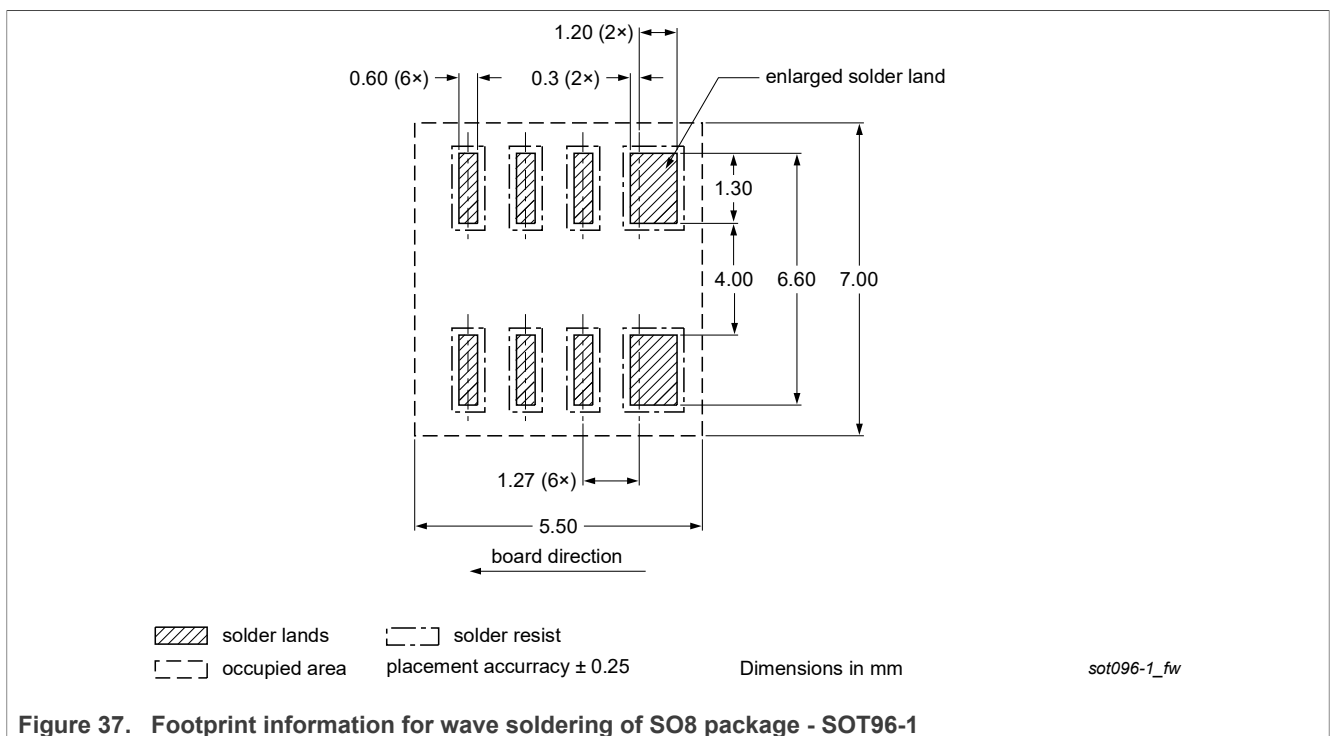
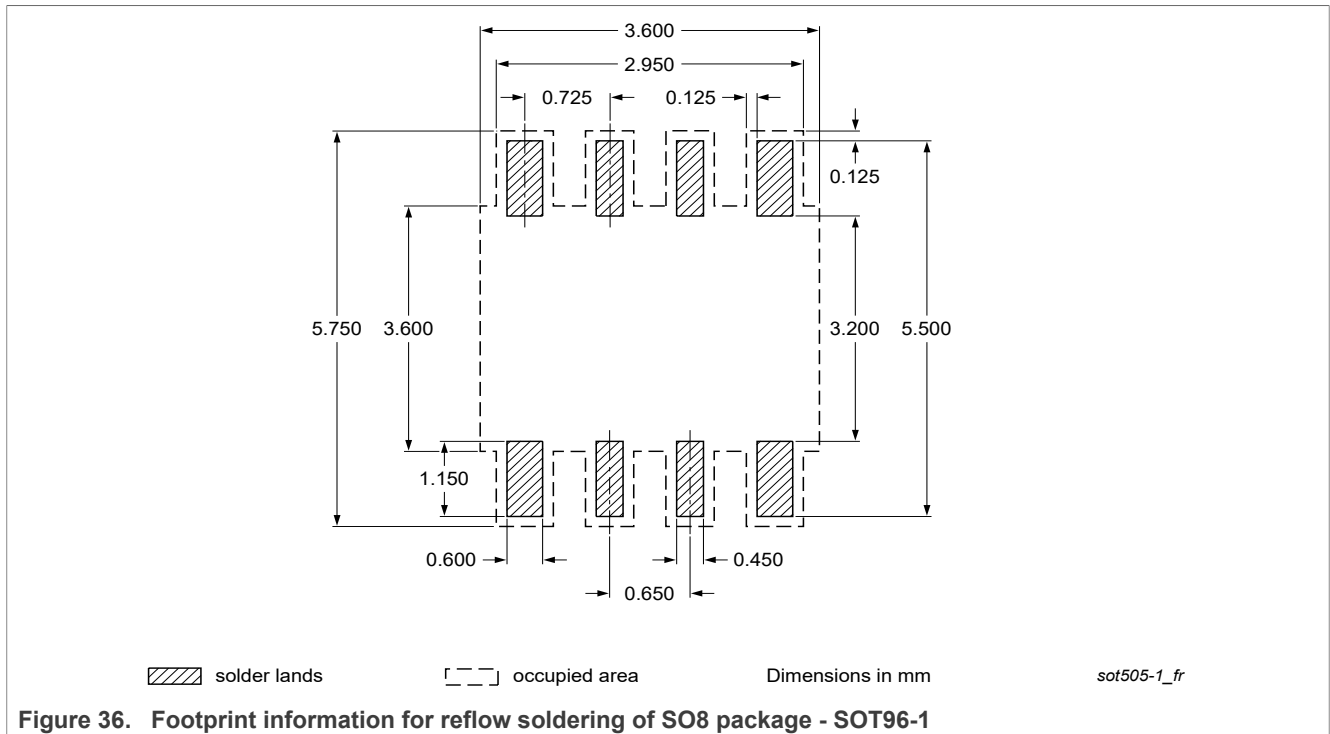

Find [here](#) detailed package and soldering information.

15 Handling information

CAUTION



This device is sensitive to ElectroStatic Discharge (ESD). Observe precautions for handling electrostatic sensitive devices.

Such precautions are described in the *ANSI/ESD S20.20*, *IEC/ST 61340-5*, *JESD625-A* or equivalent standards.

For assembly guidelines refer to [AN1902](#).

16 Abbreviations

Table 43. Abbreviations

Acronym	Description
ACK	ACKnowledge
ASID	Assembly Sequence ID
CC	Capability Container
CRC	Cyclic Redundancy Check
DBSN	Diffusion Batch Sequence number
EEPROM	Electrically Erasable Programmable Read-Only Memory
fc	carrier frequency
GND	GrouND
IC	Integrated Circuit
I ² C	Inter-Integrated Circuit
LSB	Least Significant Bit
MCU	Micro-Controller Unit
MSB	Most Significant Bit
NAK	Not-Acknowledge
NDEF	NFC Data Exchange Format
NFC	Near Field Communication
POR	Power-On Reset
RF	Radio Frequency
RFU	Reserved for Future Use
SRAM	Static Random-Access Memory
TLV	Tag - Length - Value
UID	Unique IDentifier

17 References

- [1] NFC Forum - Digital Protocol Technical Specification
<https://nfc-forum.org/product-category/specification/>
- [2] NFC Forum - Activity Technical Specification
<https://nfc-forum.org/product-category/specification/>
- [3] NFC Forum - Type 2 Tag Technical Specification
<https://nfc-forum.org/product-category/specification/>
- [4] Explorer Kit Development NFC Forum Certificate
https://nfc-forum.org/wp-content/uploads/2017/08/NXP_NTAG_I%C2%B2C- CertID_58514.pdf
- [5] ISO/IEC 14443 - Identification cards - Contactless integrated circuit cards - Proximity cards
<https://www.iso.org/ics/35.240.15/x/>
- [6] ISO/IEC 7816-6 - Identification cards - Integrated circuit cards - Interindustry data elements for interchange
<https://www.iso.org/ics/35.240.15/x/>
- [7] UM10204 I²C-bus specification and user manual
<https://www.nxp.com/docs/en/user-guide/UM10204.pdf>
- [8] AN11276 NTAG Antenna Design Guide
<https://www.nxp.com/docs/en/application-note/AN11276.zip>
- [9] AN11350 NTAG21x Originality Signature Validation
<https://www.nxp.com/confidential/AN11350>
- [10] AN11578 NTAG I²C energy harvesting
http://www.nxp.com/documents/application_note/AN11578.pdf
- [11] AN11579 How to use the NTAG I²C (*plus*) for bidirectional communication
http://www.nxp.com/documents/application_note/AN11579.pdf
- [12] AN11786 Memory Configuration Options
http://www.nxp.com/documents/application_note/AN11786.pdf
- [13] XQFN8 - SOT902-3 package and soldering information
<https://www.nxp.com/docs/en/package-information/SOT902-3.pdf>
- [14] TSSOP8 - SOT505-1 package and soldering information
<https://www.nxp.com/docs/en/package-information/SOT505-1.pdf>
- [15] SO8 - SOT96-1 package and soldering information
<https://www.nxp.com/docs/en/package-information/SOT96-1.pdf>
- [16] AN1902 Assembly guidelines for QFN and SON packages
<https://www.nxp.com/docs/en/application-note/AN1902.pdf>
- [17] Certicom Research SEC 2: Recommended Elliptic Curve Domain Parameters V2.0
<https://www.secg.org/sec2-v2.pdf>

18 Revision history

Table 44. Revision history

Document ID	Release date	Data sheet status	Change notice	Supersedes
NT3H2111_2211 v. 3.6	20230721	Product data sheet	-	NT3H2111_2211 v. 3.5
Modifications:	<ul style="list-style-type: none"> • Remove the wafer deliver form • Clarifying the condition NFC_PORT bit • Add the compatibility related information with a mobile • Editorial updates 			
NT3H2111_2211 v. 3.5	20190507	Product data sheet	-	NT3H2111_2211 v. 3.4
NT3H2111_2211 v. 3.4	20190108	Product data sheet	-	NT3H2111_2211 v. 3.3
NT3H2111_2211 v. 3.3	20180808	Product data sheet	-	NT3H2111_2211 v. 3.2
NT3H2111_2211 v. 3.2	20171130	Product data sheet	-	NT3H2111_2211 v. 3.1
NT3H2111_2211 v. 3.1	20171009	Product data sheet	-	v. 3.0
NT3H2111_2211 v. 3.0	20160203	Product data sheet	-	-

19 Legal information

19.1 Data sheet status

Document status ^{[1][2]}	Product status ^[3]	Definition
Objective [short] data sheet	Development	This document contains data from the objective specification for product development.
Preliminary [short] data sheet	Qualification	This document contains data from the preliminary specification.
Product [short] data sheet	Production	This document contains the product specification.

[1] Please consult the most recently issued document before initiating or completing a design.

[2] The term 'short data sheet' is explained in section "Definitions".

[3] The product status of device(s) described in this document may have changed since this document was published and may differ in case of multiple devices. The latest product status information is available on the Internet at URL <http://www.nxp.com>.

19.2 Definitions

Draft — A draft status on a document indicates that the content is still under internal review and subject to formal approval, which may result in modifications or additions. NXP Semiconductors does not give any representations or warranties as to the accuracy or completeness of information included in a draft version of a document and shall have no liability for the consequences of use of such information.

Short data sheet — A short data sheet is an extract from a full data sheet with the same product type number(s) and title. A short data sheet is intended for quick reference only and should not be relied upon to contain detailed and full information. For detailed and full information see the relevant full data sheet, which is available on request via the local NXP Semiconductors sales office. In case of any inconsistency or conflict with the short data sheet, the full data sheet shall prevail.

Product specification — The information and data provided in a Product data sheet shall define the specification of the product as agreed between NXP Semiconductors and its customer, unless NXP Semiconductors and customer have explicitly agreed otherwise in writing. In no event however, shall an agreement be valid in which the NXP Semiconductors product is deemed to offer functions and qualities beyond those described in the Product data sheet.

19.3 Disclaimers

Limited warranty and liability — Information in this document is believed to be accurate and reliable. However, NXP Semiconductors does not give any representations or warranties, expressed or implied, as to the accuracy or completeness of such information and shall have no liability for the consequences of use of such information. NXP Semiconductors takes no responsibility for the content in this document if provided by an information source outside of NXP Semiconductors.

In no event shall NXP Semiconductors be liable for any indirect, incidental, punitive, special or consequential damages (including - without limitation - lost profits, lost savings, business interruption, costs related to the removal or replacement of any products or rework charges) whether or not such damages are based on tort (including negligence), warranty, breach of contract or any other legal theory.

Notwithstanding any damages that customer might incur for any reason whatsoever, NXP Semiconductors' aggregate and cumulative liability towards customer for the products described herein shall be limited in accordance with the Terms and conditions of commercial sale of NXP Semiconductors.

Right to make changes — NXP Semiconductors reserves the right to make changes to information published in this document, including without limitation specifications and product descriptions, at any time and without notice. This document supersedes and replaces all information supplied prior to the publication hereof.

Suitability for use — NXP Semiconductors products are not designed, authorized or warranted to be suitable for use in life support, life-critical or safety-critical systems or equipment, nor in applications where failure or malfunction of an NXP Semiconductors product can reasonably be expected to result in personal injury, death or severe property or environmental damage. NXP Semiconductors and its suppliers accept no liability for inclusion and/or use of NXP Semiconductors products in such equipment or applications and therefore such inclusion and/or use is at the customer's own risk.

Applications — Applications that are described herein for any of these products are for illustrative purposes only. NXP Semiconductors makes no representation or warranty that such applications will be suitable for the specified use without further testing or modification.

Customers are responsible for the design and operation of their applications and products using NXP Semiconductors products, and NXP Semiconductors accepts no liability for any assistance with applications or customer product design. It is customer's sole responsibility to determine whether the NXP Semiconductors product is suitable and fit for the customer's applications and products planned, as well as for the planned application and use of customer's third party customer(s). Customers should provide appropriate design and operating safeguards to minimize the risks associated with their applications and products.

NXP Semiconductors does not accept any liability related to any default, damage, costs or problem which is based on any weakness or default in the customer's applications or products, or the application or use by customer's third party customer(s). Customer is responsible for doing all necessary testing for the customer's applications and products using NXP Semiconductors products in order to avoid a default of the applications and the products or of the application or use by customer's third party customer(s). NXP does not accept any liability in this respect.

Limiting values — Stress above one or more limiting values (as defined in the Absolute Maximum Ratings System of IEC 60134) will cause permanent damage to the device. Limiting values are stress ratings only and (proper) operation of the device at these or any other conditions above those given in the Recommended operating conditions section (if present) or the Characteristics sections of this document is not warranted. Constant or repeated exposure to limiting values will permanently and irreversibly affect the quality and reliability of the device.

Terms and conditions of commercial sale — NXP Semiconductors products are sold subject to the general terms and conditions of commercial sale, as published at <http://www.nxp.com/profile/terms>, unless otherwise agreed in a valid written individual agreement. In case an individual agreement is concluded only the terms and conditions of the respective agreement shall apply. NXP Semiconductors hereby expressly objects to applying the customer's general terms and conditions with regard to the purchase of NXP Semiconductors products by customer.

No offer to sell or license — Nothing in this document may be interpreted or construed as an offer to sell products that is open for acceptance or the grant, conveyance or implication of any license under any copyrights, patents or other industrial or intellectual property rights.

NTAG I²C plus: NFC Forum T2T with I²C interface, password protection and energy harvesting

Quick reference data — The Quick reference data is an extract of the product data given in the Limiting values and Characteristics sections of this document, and as such is not complete, exhaustive or legally binding.

Export control — This document as well as the item(s) described herein may be subject to export control regulations. Export might require a prior authorization from competent authorities.

Suitability for use in non-automotive qualified products — Unless this document expressly states that this specific NXP Semiconductors product is automotive qualified, the product is not suitable for automotive use. It is neither qualified nor tested in accordance with automotive testing or application requirements. NXP Semiconductors accepts no liability for inclusion and/or use of non-automotive qualified products in automotive equipment or applications.

In the event that customer uses the product for design-in and use in automotive applications to automotive specifications and standards, customer (a) shall use the product without NXP Semiconductors' warranty of the product for such automotive applications, use and specifications, and (b) whenever customer uses the product for automotive applications beyond NXP Semiconductors' specifications such use shall be solely at customer's own risk, and (c) customer fully indemnifies NXP Semiconductors for any liability, damages or failed product claims resulting from customer design and use of the product for automotive applications beyond NXP Semiconductors' standard warranty and NXP Semiconductors' product specifications.

Translations — A non-English (translated) version of a document, including the legal information in that document, is for reference only. The English version shall prevail in case of any discrepancy between the translated and English versions.

NXP B.V. - NXP B.V. is not an operating company and it does not distribute or sell products.

19.4 Licenses

Purchase of NXP ICs with NFC technology — Purchase of an NXP Semiconductors IC that complies with one of the Near Field Communication (NFC) standards ISO/IEC 18092 and ISO/IEC 21481 does not convey an implied license under any patent right infringed by implementation of any of those standards. Purchase of NXP Semiconductors IC does not include a license to any NXP patent (or other IP right) covering combinations of those products with other products, whether hardware or software.

19.5 Trademarks

Notice: All referenced brands, product names, service names, and trademarks are the property of their respective owners.

NXP — wordmark and logo are trademarks of NXP B.V.

I²C-bus — logo is a trademark of NXP B.V.

NTAG — is a trademark of NXP B.V.

Tables

Tab. 1.	Ordering information	5	Tab. 27.	READ command	52
Tab. 2.	Marking codes	6	Tab. 28.	READ timing	53
Tab. 3.	Pin description for XQFN8, TSSOP8 and SO8	9	Tab. 29.	FAST_READ command	53
Tab. 4.	NTAG I2C plus 1k memory organization from the NFC perspective	14	Tab. 30.	FAST_READ timing	54
Tab. 5.	NTAG I2C plus 2k memory organization from the NFC perspective	16	Tab. 31.	WRITE command	55
Tab. 6.	NTAG I2C plus 1k memory organization from the I2C perspective	19	Tab. 32.	WRITE timing	55
Tab. 7.	NTAG I2C plus 2k memory organization from the I2C perspective	21	Tab. 33.	FAST_WRITE command	56
Tab. 8.	Minimum memory content to be in initialized state for NTAG I2C plus	26	Tab. 34.	FAST_WRITE timing	56
Tab. 9.	Password and Access Configuration Register	28	Tab. 35.	SECTOR_SELECT command	57
Tab. 10.	Password and Access Configuration bytes	28	Tab. 36.	SECTOR_SELECT timing	57
Tab. 11.	Configuration bytes NTAG I2C plus	29	Tab. 37.	Illustration of the SRAM memory addressing via the NFC interface (with SRAM_MIRROR_ON_OFF set to 1b and SRAM_MIRROR_BLOCK set to 01h) for the NTAG I2C plus 1k	59
Tab. 12.	Session bytes NTAG I2C plus	30	Tab. 38.	Illustration of the SRAM memory addressing via the NFC interface (with SRAM_MIRROR_ON_OFF set to 1b and SRAM_MIRROR_BLOCK set to 01h) for the NTAG I2C plus 2k	60
Tab. 13.	Configuration bytes	31	Tab. 39.	Illustration of the SRAM memory addressing via the NFC interface in pass-through mode (PTHRU_ON_OFF set to 1b) for the NTAG I2C plus 1k	62
Tab. 14.	Session register bytes	33	Tab. 40.	Illustration of the SRAM memory addressing via the NFC interface in pass-through mode (PTHRU_ON_OFF set to 1b) for the NTAG I2C plus 2k	63
Tab. 15.	Default NTAG I2C plus address from I2C	43	Tab. 41.	Limiting values	67
Tab. 16.	Command overview	47	Tab. 42.	Characteristics	68
Tab. 17.	ACK and NAK values	48	Tab. 43.	Abbreviations	77
Tab. 18.	ATQA response of the NTAG I2C plus	48	Tab. 44.	Revision history	79
Tab. 19.	SAK response of the NTAG I2C plus	49			
Tab. 20.	GET_VERSION command	49			
Tab. 21.	GET_VERSION timing	49			
Tab. 22.	GET_VERSION response	50			
Tab. 23.	READ_SIG command	51			
Tab. 24.	READ_SIG timing	51			
Tab. 25.	PWD_AUTH command	52			
Tab. 26.	PWD_AUTH timing	52			

Figures

Fig. 1.	Contactless and contact system	1	Fig. 20.	Frame Delay Time (from NFC device to NFC tag), TACK and TNAK	48
Fig. 2.	Block diagram	7	Fig. 21.	GET_VERSION command	49
Fig. 3.	Pin configuration for XQFN8	8	Fig. 22.	READ_SIG command	50
Fig. 4.	Pin configuration for TSSOP8	8	Fig. 23.	PWD_AUTH command	51
Fig. 5.	Pin configuration for SO8	8	Fig. 24.	READ command	52
Fig. 6.	NFC state machine of NTAG I2C plus	11	Fig. 25.	FAST_READ command	53
Fig. 7.	Serial number (UID)	23	Fig. 26.	WRITE command	55
Fig. 8.	Static lock bytes 0 and 1	23	Fig. 27.	FAST_WRITE command	56
Fig. 9.	NTAG I2C plus 1k Dynamic lock bytes 0, 1 and 2	24	Fig. 28.	SECTOR_SELECT command	57
Fig. 10.	NTAG I2C plus 2k Dynamic lock bytes 0, 1 and 2	25	Fig. 29.	Illustration of the Field detection feature in combination with the pass-through mode for data transfer from NFC to I2C	65
Fig. 11.	Possible configuration of CC bytes of NTAG I2C plus 1k version	26	Fig. 30.	Illustration of the Field detection signal feature in combination with pass-through mode for data transfer from I2C to NFC	66
Fig. 12.	FD pin example circuit	35	Fig. 31.	Package outline SOT902-3 (XQFN8)	70
Fig. 13.	Illustration of the field detection feature when configured for simple field detection	35	Fig. 32.	Footprint information for reflow soldering of XQFN8 package - SOT902-3	71
Fig. 14.	Illustration of the field detection feature when configured for first valid start of communication detection	36	Fig. 33.	Package outline SOT505-1 (TSSOP8)	72
Fig. 15.	Illustration of the field detection feature when configured for selection of the tag detection	37	Fig. 34.	Footprint information for reflow soldering of TSSOP8 package - SOT505-1	73
Fig. 16.	Energy harvesting example circuit	38	Fig. 35.	Package outline SOT96-1 (SO8)	74
Fig. 17.	I2C bus protocol	41	Fig. 36.	Footprint information for reflow soldering of SO8 package - SOT96-1	75
Fig. 18.	I2C READ and WRITE operation	44	Fig. 37.	Footprint information for wave soldering of SO8 package - SOT96-1	75
Fig. 19.	WRITE and READ register operation	46			

Contents

1	General description	1	9.2	Stop condition	41
2	Features and benefits	2	9.3	I2C soft reset and NFC disable feature	42
2.1	Key features	2	9.4	Acknowledge bit (ACK)	42
2.2	NFC interface	2	9.5	Data input	42
2.3	Memory	3	9.6	Addressing	42
2.4	I2C interface	3	9.7	READ and WRITE Operation	43
2.5	Security	3	9.8	WRITE and READ register operation	46
2.6	Key benefits	3	10	NFC Command	47
3	Applications	4	10.1	NTAG I2C plus command overview	47
4	Ordering information	5	10.2	Timing	47
5	Marking	6	10.3	NTAG ACK and NAK	48
6	Block diagram	7	10.4	ATQA and SAK responses	48
7	Pinning information	8	10.5	GET_VERSION	49
7.1	Pinning	8	10.6	READ_SIG	50
7.1.1	XQFN8	8	10.7	PWD_AUTH	51
7.1.2	TSSOP8	8	10.8	READ	52
7.1.3	SO8	8	10.9	FAST_READ	53
7.2	Pin description	9	10.10	WRITE	54
8	Functional description	10	10.11	FAST_WRITE	55
8.1	Block description	10	10.12	SECTOR SELECT	56
8.2	NFC interface	10	11	Communication and arbitration between NFC and I2C interface	58
8.2.1	Data integrity	10	11.1	Pass-through mode not activated	58
8.2.2	NFC state machine	11	11.1.1	I2C interface access	58
8.2.2.1	IDLE state	11	11.1.2	NFC interface access	58
8.2.2.2	READY 1 state	11	11.2	SRAM buffer mapping with Memory Mirror enabled	58
8.2.2.3	READY 2 state	12	11.3	Pass-through mode	61
8.2.2.4	ACTIVE state	12	11.3.1	SRAM buffer mapping	62
8.2.2.5	AUTHENTICATED state	12	11.3.2	NFC to I2C data transfer	64
8.2.2.6	HALT state	12	11.3.3	I2C to NFC data transfer	65
8.3	Memory organization	13	12	Limiting values	67
8.3.1	Memory map from NFC perspective	13	13	Characteristics	68
8.3.2	Memory map from I2C interface	18	13.1	Electrical characteristics	68
8.3.3	EEPROM	22	14	Package outline	70
8.3.4	SRAM	22	15	Handling information	76
8.3.5	Serial number (UID)	22	16	Abbreviations	77
8.3.6	Static Lock Bytes	23	17	References	78
8.3.7	Dynamic Lock Bytes	23	18	Revision history	79
8.3.8	Capability Container (CC)	25	19	Legal information	80
8.3.9	User Memory pages	26			
8.3.10	Memory content at delivery	26			
8.3.11	Password and Access Configuration	26			
8.3.12	NTAG I2C plus configuration and session registers	29			
8.4	Configurable Field Detection Pin	34			
8.5	Watchdog timer	37			
8.6	Energy harvesting	38			
8.7	Password authentication	38			
8.7.1	Programming of PWD and PACK	39			
8.7.2	Limiting negative verification attempts	39			
8.7.3	Protection of configuration segments	39			
8.8	Originality signature	39			
9	I2C commands	41			
9.1	Start condition	41			

Please be aware that important notices concerning this document and the product(s) described herein, have been included in section 'Legal information'.

Looking for pricing, stock, or lifecycle information?

Click below to explore more details on WIN SOURCE:

- ⊖ [View NT3H211W0FTTJ on WIN SOURCE](#)
- ⊖ [NXP / Nexperia Information](#)

Optimize Your Supply Chain with WIN SOURCE Solutions

- ✓ Global Sourcing Solution
- ✓ Obsolete Management
- ✓ Cost Control Management
- ✓ Shortage Management
- ✓ Alternative Solution
- ✓ Excess Inventory Management