



**THE DATASHEET OF
8SLVD2102NLGI**



Description

The 8SLVD2102 is a high-performance differential dual 1:2 LVDS fanout buffer. The device is designed for the fanout of high-frequency, very low additive phase-noise clock and data signals. The 8SLVD2102 is characterized to operate from a 2.5V power supply. Guaranteed output-to-output and part-to-part skew characteristics make the 8SLVD2102 ideal for those clock distribution applications demanding well-defined performance and repeatability.

Two independent buffers with two low skew outputs each are available. The integrated bias voltage generators enables easy interfacing of single-ended signals to the device inputs. The device is optimized for low power consumption and low additive phase noise.

Features

- Two 1:2, low skew, low additive jitter LVDS fanout buffers
- Two differential clock inputs
- Differential pairs can accept the following differential input levels: LVDS and LVPECL
- Maximum input clock frequency: 2GHz
- Output bank skew: 15ps (maximum)
- Propagation delay: 300ps (maximum)
- Low additive phase jitter: 200fs, RMS (maximum); $f_{REF} = 156.25\text{MHz}$, $V_{PP} = 1\text{V}$, $V_{CMR} = 1\text{V}$, Integration Range 10kHz - 20MHz
- 2.5V supply voltage
- Maximum device current consumption (I_{DD}): 90mA
- Lead-free (RoHS 6) 16-Lead VFQFPN package
- -40°C to 85°C ambient operating temperature

Block Diagram

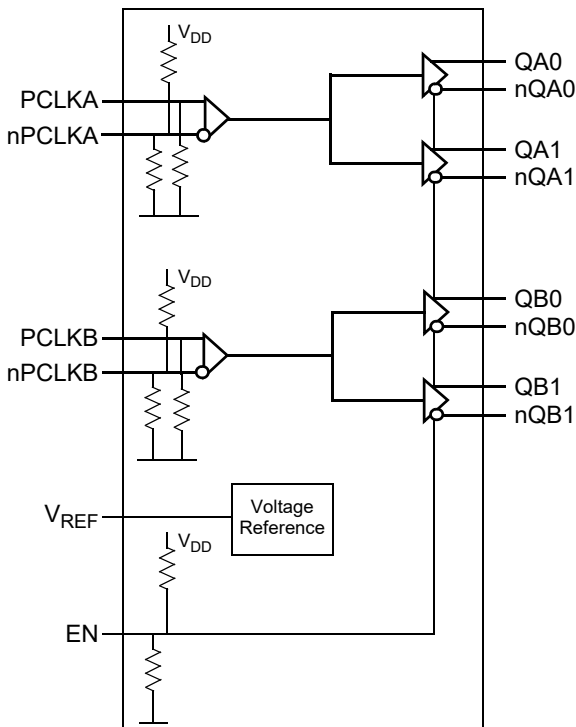

Pin Assignment

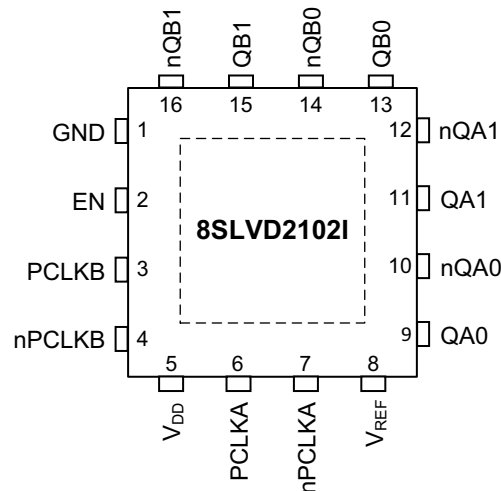

16-pin, 3.0 x 3.0 mm VFQFPN Package

Pin Description and Pin Characteristic Tables

Table 1. Pin Descriptions

Number	Name	Type		Description
1	GND	Power		Power supply ground.
2	EN	Input	Pullup/ Pulldown	Output enable pin.
3	PCLKB	Input	Pulldown	Non-inverting differential clock/data input.
4	nPCLKB	Input	Pullup/ Pulldown	Inverting differential clock/data input. $V_{DD}/2$ default when left floating.
5	V_{DD}	Power		Power supply pin.
6	PCLKA	Input	Pulldown	Non-inverting differential clock/data input.
7	nPCLKA	Input	Pullup/ Pulldown	Inverting differential clock/data input. $V_{DD}/2$ default when left floating.
8	V_{REF}	Output		Bias voltage reference for the PCLKx, nPCLKx inputs.
9, 10	QA0, nQA0	Output		Differential output pair. LVDS interface levels.
11, 12	QA1, nQA1	Output		Differential output pair. LVDS interface levels.
13, 14	QB0, nQB0	Output		Differential output pair. LVDS interface levels.
15, 16	QB1, nQB1	Output		Differential output pair. LVDS interface levels.

NOTE: *Pulldown* and *Pullup* refer to internal input resistors. See Table 2, *Pin Characteristics*, for typical values.

Table 2. Pin Characteristics

Symbol	Parameter		Test Conditions	Minimum	Typical	Maximum	Units
C_{IN}	Input Capacitance				2		pF
$R_{PULLDOWN}$	Input Pulldown Resistor	PCLK inputs			51		k Ω
R_{PULLUP}	Input Pullup Resistor	PCLK inputs			51		k Ω
$R_{PULLDOWN}$	Input Pulldown Resistor	EN input			51		k Ω
R_{PULLUP}	Input Pullup Resistor	EN input			51		k Ω

Table 3. EN Input Selection Function Table

Input	Operation
0 (Low)	Outputs are disabled and outputs are static at $Qx = 0$ (low level) and $nQx = 1$ (high level).
1 (High)	Bank A outputs are enabled and Bank B outputs are disabled at the following static levels: $QBx = 0$ (low level) and $nQBx = 1$ (high level).
Open	All outputs enabled.

NOTE: EN is an asynchronous control.

Absolute Maximum Ratings

NOTE: Stresses beyond those listed under *Absolute Maximum Ratings* may cause permanent damage to the device. These ratings are stress specifications only. Functional operation of the product at these conditions or any conditions beyond those listed in the *DC Characteristics* or *AC Characteristics* is not implied. Exposure to absolute maximum rating conditions for extended periods may affect product reliability.

Item	Rating
Supply Voltage, V_{DD}	4.6V
Inputs, V_I	-0.5V to $V_{DD} + 0.5V$
Outputs, I_O (LVDS) Continuous Current Surge Current	10mA 15mA
Maximum Junction Temperature, $T_{J,MAX}$	125°C
Storage Temperature, T_{STG}	-65°C to 150°C
ESD - Human Body Model; NOTE 1	2000V
ESD - Charged Device Model; NOTE 1	1500V

NOTE 1: According to JEDEC/JESD JS-001-2012/22-C101E.

DC Electrical Characteristics

Table 4A. Power Supply DC Characteristics, $V_{DD} = 2.5V \pm 5\%$, $T_A = -40^\circ C$ to $85^\circ C$

Symbol	Parameter	Test Conditions	Minimum	Typical	Maximum	Units
V_{DD}	Power Supply Voltage		2.375	2.5	2.625	V
I_{DD}	Power Supply Current	All outputs terminated 100Ω between nQx, Qx		80	90	mA

Table 4B. Output Enable (EN) Input DC Characteristics, $V_{DD} = 2.5V \pm 5\%$, $T_A = -40^\circ C$ to $85^\circ C$

Symbol	Parameter	Test Conditions	Minimum	Typical	Maximum	Units
V_{MID}	Input Voltage - Open Pin	Open		$V_{DD} / 2$		V
V_{IH}	Input High Voltage		$0.8 * V_{DD}$		$V_{DD} + 0.3$	V
V_{IL}	Input Low Voltage		-0.3		$0.2 * V_{DD}$	V
I_{IH}	Input High Current	$V_{DD} = V_{IN} = 2.625V$			150	μA
I_{IL}	Input Low Current	$V_{DD} = 2.625V, V_{IN} = 0V$	-150			μA

Table 4C. Differential Input Characteristics, $V_{DD} = 2.5V \pm 5\%$, $T_A = -40^{\circ}C$ to $85^{\circ}C$

Symbol	Parameter	Test Conditions	Minimum	Typical	Maximum	Units
I_{IH}	Input High Current	PCLKA, nPCLKA PCLKB, nPCLKB $V_{DD} = V_{IN} = 2.625V$			150	μA
I_{IL}	Input Low Current	PCLKA, PCLKB $V_{DD} = 2.625V, V_{IN} = 0V$	-10			μA
		nPCLKA, nPCLKB $V_{DD} = 2.625V, V_{IN} = 0V$	-150			μA
V_{REF_AC}	Reference Voltage for Input Bias	$V_{DD} = 2.5V, I_{REF} = +100\mu A$	1.00		1.35	V
V_{PP}	Peak-to-Peak Voltage; NOTE 1	$f_{REF} < 1.5 GHz$	0.15		1.6	V
		$f_{REF} > 1.5 GHz$	0.2		1.6	V
V_{CMR}	Common Mode Input Voltage; NOTE 1, 2		1		$V_{DD} - V_{PP}/2$	V

NOTE 1: V_{IL} should not be less than $-0.3V$. V_{IH} should be less than V_{DD} .

NOTE 2: Common mode input voltage is defined at the crosspoint.

Table 4D. LVDS Output DC Characteristics, $V_{DD} = 2.5V \pm 5\%$, $T_A = -40^{\circ}C$ to $85^{\circ}C$

Symbol	Parameter	Test Conditions	Minimum	Typical	Maximum	Units
V_{OD}	Differential Output Voltage	100Ω termination between nQx, Qx	247		454	mV
ΔV_{OD}	V_{OD} Magnitude Change	100Ω termination between nQx, Qx			50	mV
V_{OS}	Offset Voltage	100Ω termination between nQx, Qx	1.0		1.4	V
ΔV_{OS}	V_{OS} Magnitude Change	100Ω termination between nQx, Qx			50	mV

Table 5. AC Electrical Characteristics, $V_{DD} = 2.5V \pm 5\%$, $T_A = -40^{\circ}C$ to $85^{\circ}C$

Symbol	Parameter	Test Conditions	Minimum	Typical	Maximum	Units
f_{REF}	Input Frequency				2	GHz
$\Delta V/\Delta t$	Input Edge Rate		0.75			V/ns
t_{PD}	Propagation Delay; NOTE 1	PCLKA, nPCLKA to QA[0:1], nQA[0:1], PCLKB, nPCLKB to QB[0:1], nQB[0:1]	100	196	300	ps
	Channel Isolation			75		dB
$t_{sk(o)}$	Output Skew; NOTE 2, 3	QA[0:1], nQA[0:1], QB[0:1], nQB[0:1]		14	40	ps
$t_{sk(b)}$	Output Bank Skew; NOTE 3	Between Outputs within Each Bank		7	15	ps
$t_{sk(p)}$	Pulse Skew	50% Input Duty Cycle, $f_{REF} = 100MHz$	-50		50	ps
$t_{sk(pp)}$	Part-to-Part Skew; NOTE 3, 4				200	ps
t_{JIT}	Buffer Additive Phase Jitter, RMS; refer to Additive Phase Jitter Section	$f_{REF} = 1228.8MHz$, $V_{PP} = 0.2V$, $V_{CMR} = 1V$ Integration Range: 10kHz – 20MHz		20	50	fs
		$f_{REF} = 156.25MHz$, $V_{PP} = 0.5V$, $V_{CMR} = 1V$ Integration Range: 10kHz – 20MHz		140	250	fs
		$f_{REF} = 156.25MHz$, $V_{PP} = 1V$, $V_{CMR} = 1V$ Integration Range: 10kHz – 20MHz		80	200	fs
$t_{JIT, SP}$	Spurious Suppression, Coupling from QA1 to QB0	$f_{QB0} = 500MHz$, $V_{PP(PCLKB)} = 0.15V$, $V_{CMR(PCLKB)} = 1V$ and $f_{QA1} = 62.5MHz$, $V_{PP(PCLKA)} = 1V$, $V_{CMR(PCLKA)} = 1V$		68		dB
		$f_{QB0} = 500MHz$, $V_{PP(PCLKB)} = 0.15V$, $V_{CMR(PCLKB)} = 1V$ and $f_{QA1} = 15.625MHz$, $V_{PP(PCLKA)} = 1V$, $V_{CMR(PCLKA)} = 1V$		74		dB
t_R / t_F	Output Rise/ Fall Time	20% to 80%		120	200	ps

NOTE: Electrical parameters are guaranteed over the specified ambient operating temperature range, which is established when the device is mounted in a test socket with maintained transverse airflow greater than 500 lfm. The device will meet specifications after thermal equilibrium has been reached under these conditions.

NOTE 1: Measured from the differential input crossing point to the differential output crossing point.

NOTE 2: Defined as skew between outputs at the same supply voltage and with equal load conditions. Measured at the differential cross points.

NOTE 3: This parameter is defined in accordance with JEDEC Standard 65.

NOTE 4: Defined as skew between outputs on different devices operating at the same supply voltages and with equal load conditions. Using the same type of inputs on each device, the outputs are measured at the differential cross points.

Additive Phase Jitter

The spectral purity in a band at a specific offset from the fundamental compared to the power of the fundamental is called the **dBc Phase Noise**. This value is normally expressed using a Phase noise plot and is most often the specified plot in many applications. Phase noise is defined as the ratio of the noise power present in a 1Hz band at a specified offset from the fundamental frequency to the power value of the fundamental. This ratio is expressed in decibels (dBm) or a ratio

of the power in the 1Hz band to the power in the fundamental. When the required offset is specified, the phase noise is called a **dBc** value, which simply means dBm at a specified offset from the fundamental. By investigating jitter in the frequency domain, we get a better understanding of its effects on the desired application over the entire time record of the signal. It is mathematically possible to calculate an expected bit error rate given a phase noise plot.

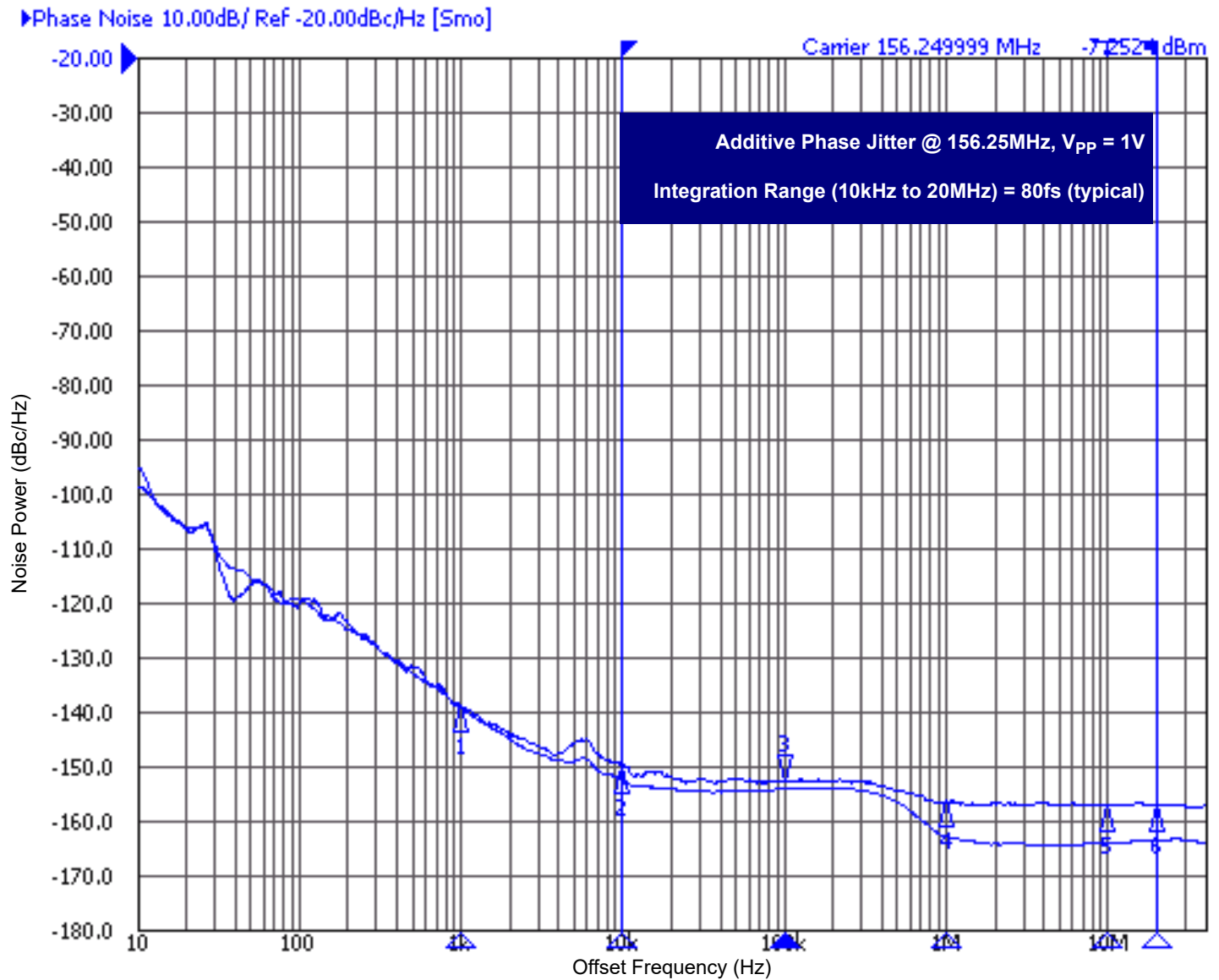

As with most timing specifications, phase noise measurements have issues relating to the limitations of the measurement equipment. The noise floor of the equipment can be higher or lower than the noise floor of the device. Additive phase noise is dependent on both the noise floor of the input source and measurement equipment.

Measured using a Rohde & Schwarz SMA100 as the input source.

Parameter Measurement Information

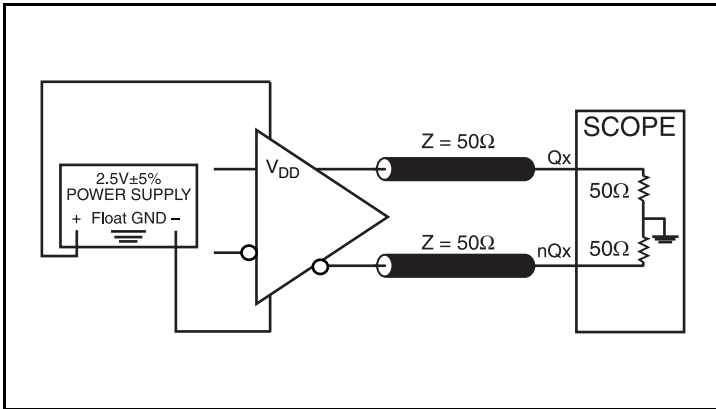

LVDS Output Load Test Circuit

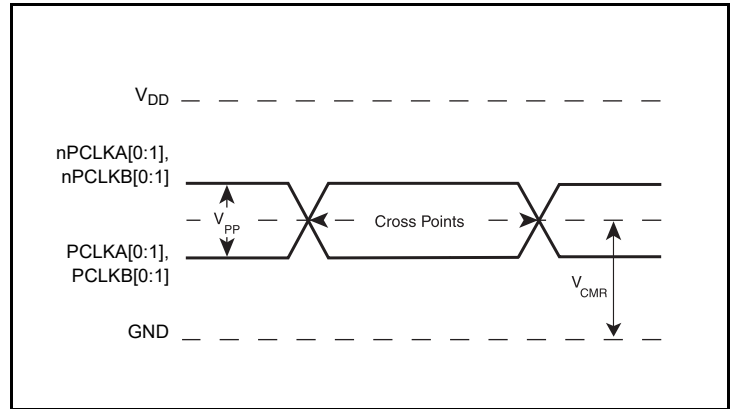

Differential Input Level

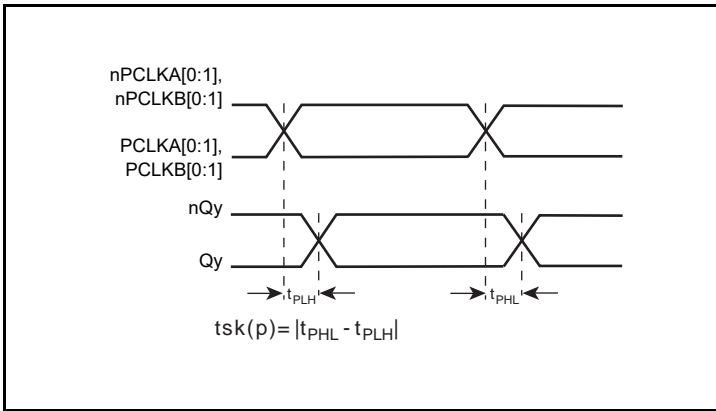

Pulse Skew

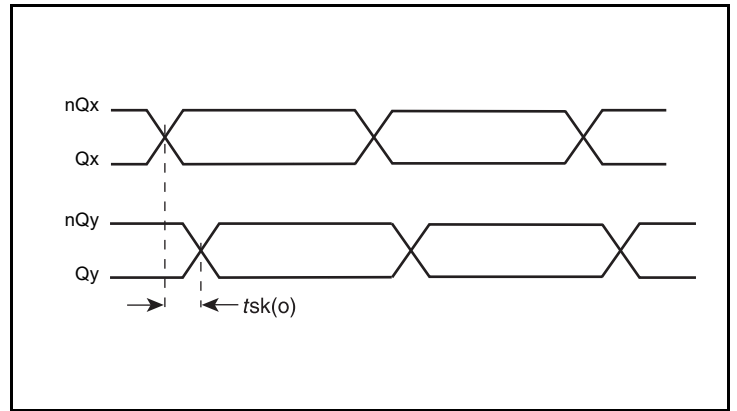

Output Skew

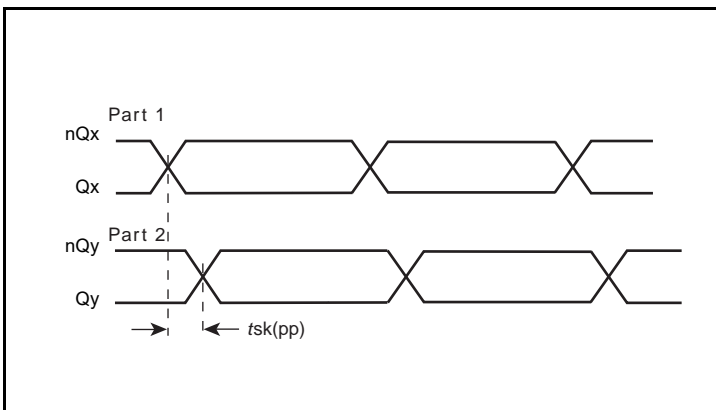

Part-to-Part Skew

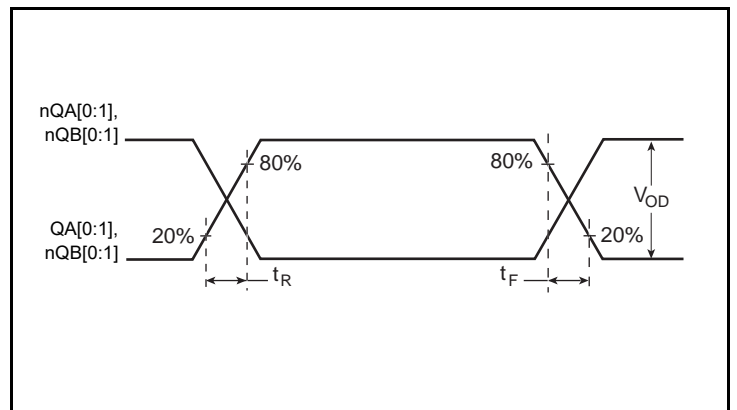

Output Rise/Fall Time

Parameter Measurement Information, continued

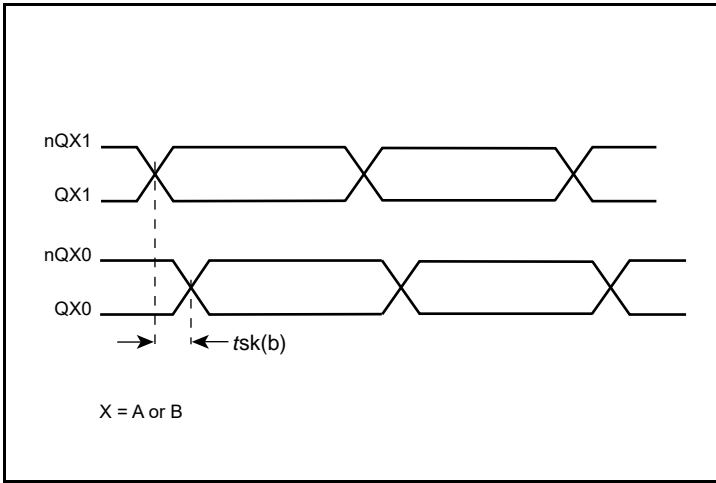

Bank Skew

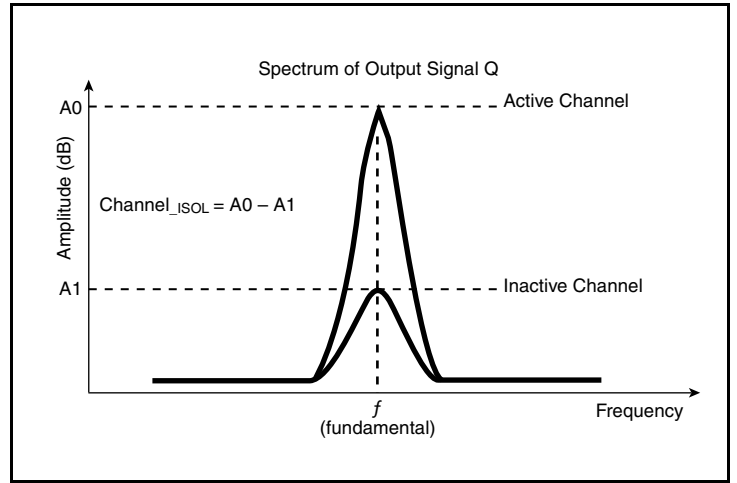

Channel Isolation

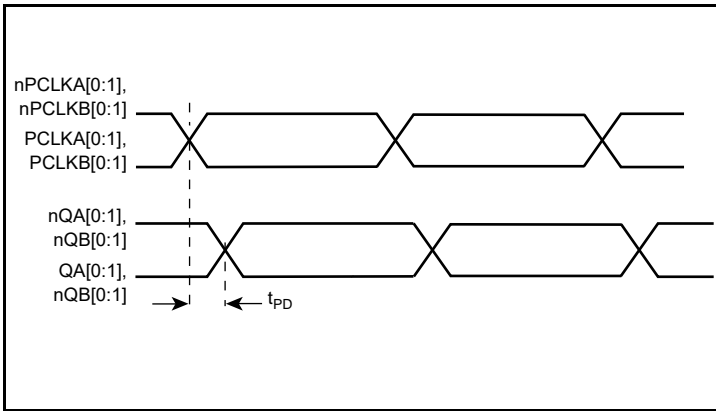

Propagation Delay

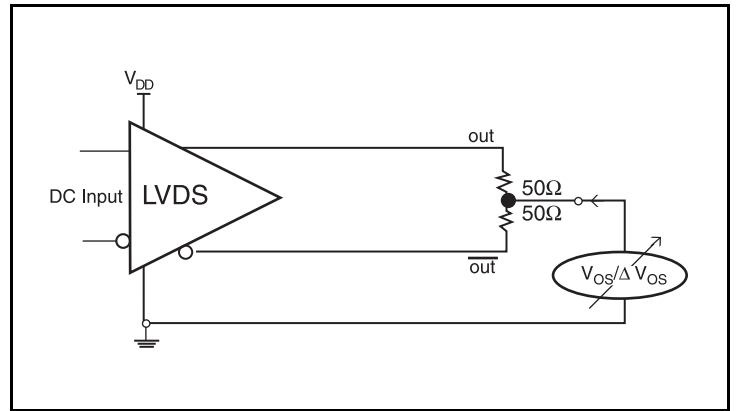

Offset Voltage Setup

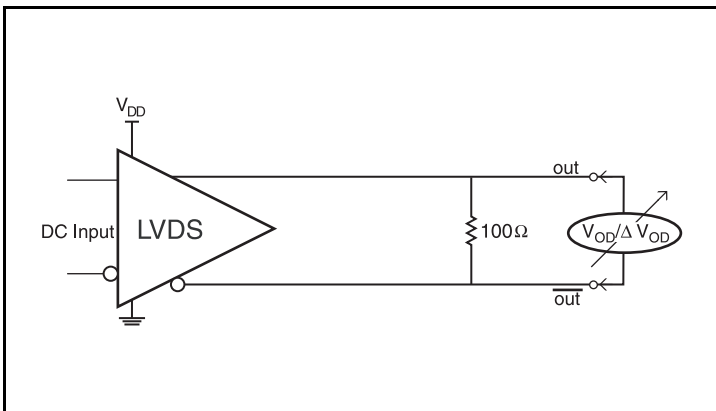

Differential Output Voltage Setup

Applications Information

Recommendations for Unused Input and Output Pins

Inputs:

PCLK/nPCLK Inputs

For applications not requiring the use of a differential input, both the PCLK and nPCLK pins can be left floating. Though not required, but for additional protection, a 1kΩ resistor can be tied from PCLK to ground.

Outputs:

LVDS Outputs

All unused LVDS output pairs can be either left floating or terminated with 100Ω across. If they are left floating, there should be no trace attached.

Wiring the Differential Input to Accept Single-Ended Levels

Figure 1 shows how a differential input can be wired to accept single ended levels. The reference voltage $V1 = V_{DD}/2$ is generated by the bias resistors R1 and R2. The bypass capacitor (C1) is used to help filter noise on the DC bias. This bias circuit should be located as close to the input pin as possible. The ratio of R1 and R2 might need to be adjusted to position the V1 in the center of the input voltage swing. For example, if the input clock swing is 2.5V and $V_{DD} = 2.5V$, R1 and R2 value should be adjusted to set V1 at 1.25V. The values below are for when both the single ended swing and V_{DD} are at the same voltage. This configuration requires that the sum of the output impedance of the driver (R_o) and the series resistance (R_s) equals the transmission line impedance. In addition, matched termination at the input will attenuate the signal in half. This can be done in one of two ways. First, R3 and R4 in parallel should equal the transmission line impedance. For most 50Ω applications, R3 and R4 can be 100Ω.

The values of the resistors can be increased to reduce the loading for slower and weaker LVCMOS driver. When using single-ended signaling, the noise rejection benefits of differential signaling are reduced. Even though the differential input can handle full rail LVCMOS signaling, it is recommended that the amplitude be reduced. The datasheet specifies a lower differential amplitude, however this only applies to differential signals. For single-ended applications, the swing can be larger, however V_{IL} cannot be less than -0.3V and V_{IH} cannot be more than $V_{DD} + 0.3V$. Suggest edge rate faster than 1V/ns. Though some of the recommended components might not be used, the pads should be placed in the layout. They can be utilized for debugging purposes. The datasheet specifications are characterized and guaranteed by using a differential signal.

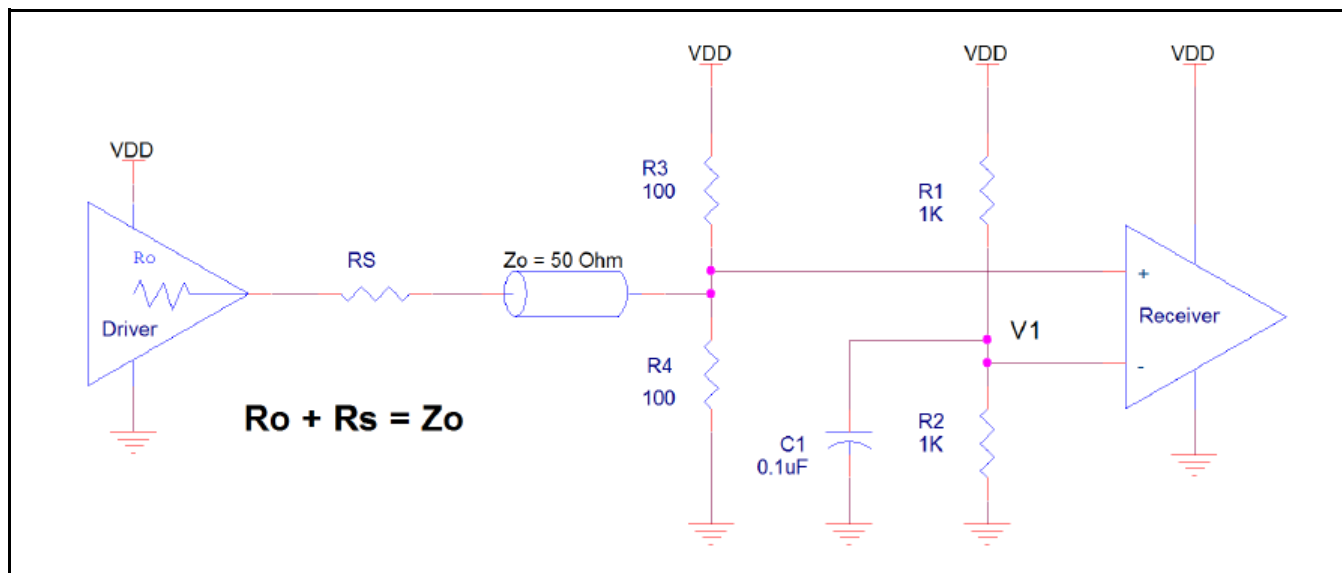

Figure 1. Recommended Schematic for Wiring a Differential Input to Accept Single-ended Levels

2.5V LVPECL Clock Input Interface

The PCLK /nPCLK accepts LVPECL, LVDS, and other differential signals. Both signals must meet the V_{PP} and V_{CMR} input requirements. *Figures 2A to 2C* show interface examples for the PCLK/ nPCLK input driven by the most common driver types. The

input interfaces suggested here are examples only. If the driver is from another vendor, use their termination recommendation. Please consult with the vendor of the driver component to confirm the driver termination requirements.

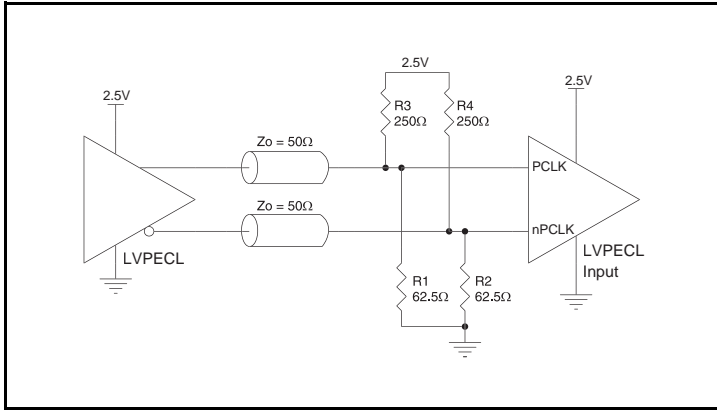

Figure 2A. PCLK/nPCLK Input Driven by a 2.5V LVPECL Driver

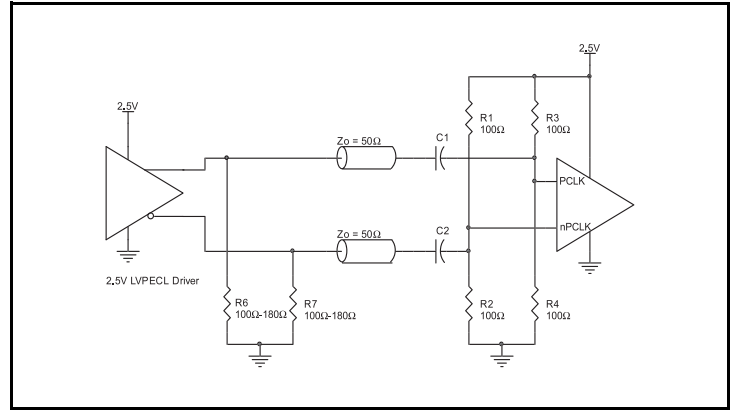

Figure 2B. PCLK/nPCLK Input Driven by a 2.5V LVPECL Driver with AC Couple

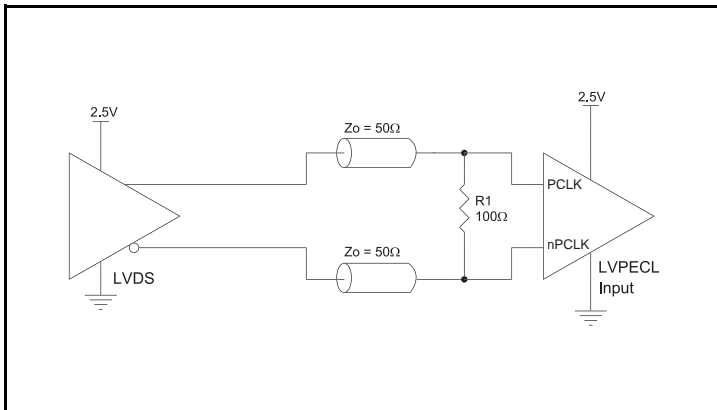
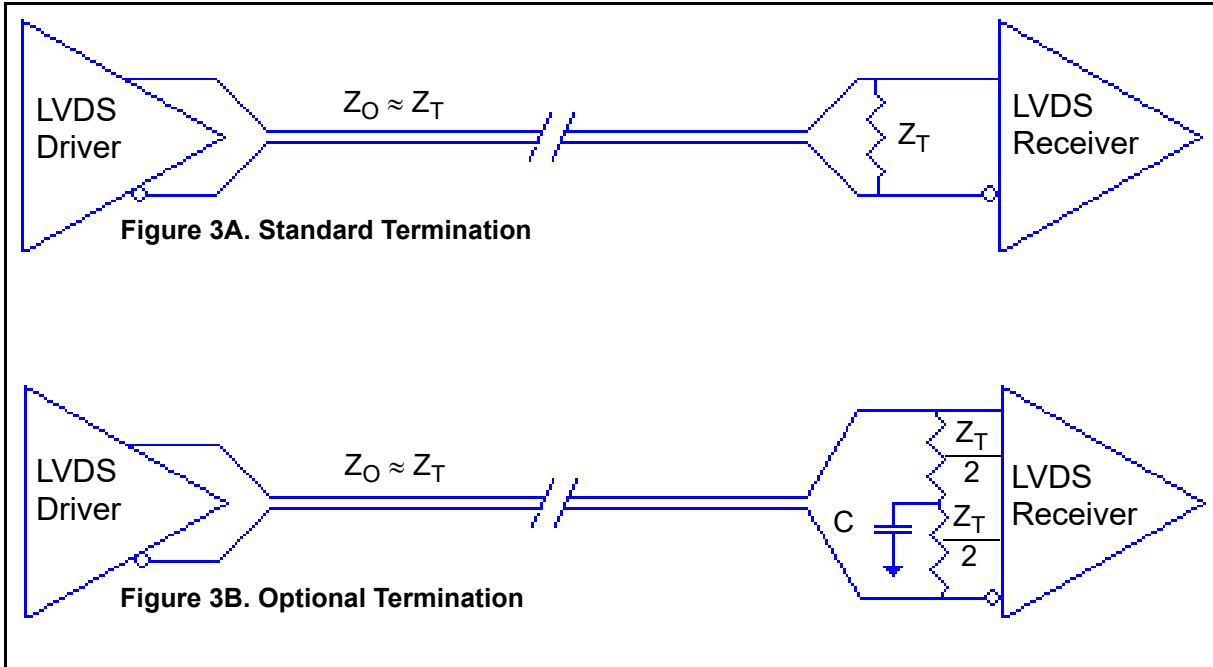

Figure 2C. PCLK/nPCLK Input Driven by a 2.5V LVDS Driver

LVDS Driver Termination

For a general LVDS interface, the recommended value for the termination impedance (Z_T) is between 90Ω and 132Ω . The actual value should be selected to match the differential impedance (Z_0) of your transmission line. A typical point-to-point LVDS design uses a 100Ω parallel resistor at the receiver and a 100Ω differential transmission-line environment. In order to avoid any transmission-line reflection issues, the components should be surface mounted and must be placed as close to the receiver as possible. IDT offers a full line of LVDS compliant devices with two types of output structures: current source and voltage source. The

standard termination schematic as shown in *Figure 3A* can be used with either type of output structure. *Figure 3B*, which can also be used with both output types, is an optional termination with center tap capacitance to help filter common mode noise. The capacitor value should be approximately 50pF . If using a non-standard termination, it is recommended to contact IDT and confirm if the output structure is current source or voltage source type. In addition, since these outputs are LVDS compatible, the input receiver's amplitude and common-mode input range should be verified for compatibility with the output.



LVDS Termination

VFQFPN EPAD Thermal Release Path

In order to maximize both the removal of heat from the package and the electrical performance, a land pattern must be incorporated on the Printed Circuit Board (PCB) within the footprint of the package corresponding to the exposed metal pad or exposed heat slug on the package, as shown in *Figure 4*. The solderable area on the PCB, as defined by the solder mask, should be at least the same size/shape as the exposed pad/slug area on the package to maximize the thermal/electrical performance. Sufficient clearance should be designed on the PCB between the outer edges of the land pattern and the inner edges of pad pattern for the leads to avoid any shorts.

While the land pattern on the PCB provides a means of heat transfer and electrical grounding from the package to the board through a solder joint, thermal vias are necessary to effectively conduct from the surface of the PCB to the ground plane(s). The land pattern must be connected to ground through these vias. The vias act as “heat pipes”. The number of vias (i.e. “heat pipes”) are application specific

and dependent upon the package power dissipation as well as electrical conductivity requirements. Thus, thermal and electrical analysis and/or testing are recommended to determine the minimum number needed. Maximum thermal and electrical performance is achieved when an array of vias is incorporated in the land pattern. It is recommended to use as many vias connected to ground as possible. It is also recommended that the via diameter should be 12 to 13mils (0.30 to 0.33mm) with 1oz copper via barrel plating. This is desirable to avoid any solder wicking inside the via during the soldering process which may result in voids in solder between the exposed pad/slug and the thermal land. Precautions should be taken to eliminate any solder voids between the exposed heat slug and the land pattern. Note: These recommendations are to be used as a guideline only. For further information, please refer to the Application Note on the Surface Mount Assembly of Amkor’s Thermally/Electrically Enhance Leadframe Base Package, Amkor Technology.

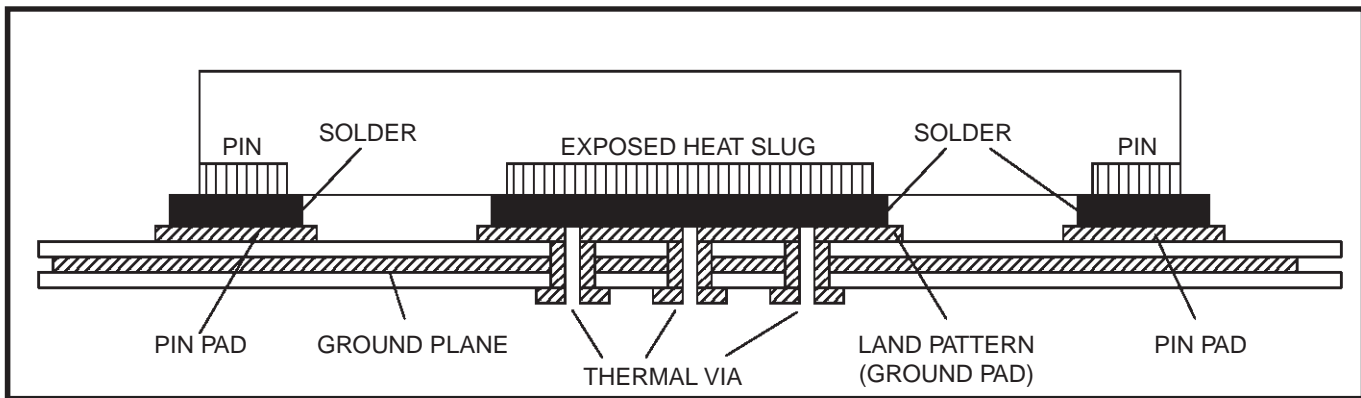

Figure 4. P.C. Assembly for Exposed Pad Thermal Release Path – Side View (drawing not to scale)

Power Considerations

This section provides information on power dissipation and junction temperature for the 8SLVD2102. Equations and example calculations are also provided.

1. Power Dissipation.

The total power dissipation for the 8SLVD2102 is the sum of the core power plus the output power dissipation due to the load. The following is the power dissipation for $V_{DD} = 2.5V + 5\% = 2.625V$, which gives worst case results.

The maximum current at 85°C is as follows: $I_{DD_MAX} = 84mA$

- $Power_{(core)MAX} = V_{DD_MAX} * I_{DD_MAX} = 2.625V * 84mA = \mathbf{220.5mW}$

Total Power_{MAX} = 220.5mW

2. Junction Temperature.

Junction temperature, T_j , is the temperature at the junction of the bond wire and bond pad directly affects the reliability of the device. The maximum recommended junction temperature is 125°C. Limiting the internal transistor junction temperature, T_j , to 125°C ensures that the bond wire and bond pad temperature remains below 125°C.

The equation for T_j is as follows: $T_j = \theta_{JA} * Pd_total + T_A$

T_j = Junction Temperature

θ_{JA} = Junction-to-Ambient Thermal Resistance

Pd_total = Total Device Power Dissipation (example calculation is in section 1 above)

T_A = Ambient Temperature

In order to calculate junction temperature, the appropriate junction-to-ambient thermal resistance θ_{JA} must be used. Assuming no air flow and a multi-layer board, the appropriate value is 74.7°C/W per Table 6 below.

Therefore, T_j for an ambient temperature of 85°C with all outputs switching is:

$$85^\circ C + 0.221W * 74.7^\circ C/W = 101.5^\circ C. \text{ This is below the limit of } 125^\circ C.$$

This calculation is only an example. T_j will obviously vary depending on the number of loaded outputs, supply voltage, air flow and the type of board (multi-layer).

Table 6. Thermal Resistance θ_{JA} for 16 Lead VFQFPN, Forced Convection

θ_{JA} at 0 Air Flow			
Meters per Second	0	1	2.5
Multi-Layer PCB, JEDEC Standard Test Boards	74.7°C/W	65.3°C/W	58.5°C/W

Reliability Information

Table 7. θ_{JA} vs. Air Flow Table for a 16 Lead VFQFPN

θ_{JA} at 0 Air Flow			
Meters per Second	0	1	2.5
Multi-Layer PCB, JEDEC Standard Test Boards	74.7°C/W	65.3°C/W	58.5°C/W

Transistor Count

The transistor count for the 8SLVD2102 is: 993

Package Outline Drawings

The package outline drawings are located at the end of this document. The package information is the most current data available and is subject to change without notice or revision of this document.

Ordering Information

Table 8. Ordering Information

Part/Order Number	Marking	Package	Shipping Packaging	Temperature
8SLVD2102NLGI	2102I	16 Lead VFQFPN, Lead-Free	Tube	-40°C to 85°C
8SLVD2102NLGI8	2102I	16 Lead VFQFPN, Lead-Free	Tape & Reel pin 1 orientation: EIA-481-C	-40°C to 85°C
8SLVD2102NLGI/W	2102I	16 Lead VFQFPN, Lead-Free	Tape & Reel pin 1 orientation: EIA-481-D	-40°C to 85°C

Table 9. Pin 1 Orientation in Tape and Reel Packaging

Part Number Suffix	Pin 1 Orientation	Illustration
8	Quadrant 1 (EIA-481-C)	
/W	Quadrant 2 (EIA-481-D)	

Revision History

Revision Date	Description of Change
January 21, 2018	<ul style="list-style-type: none"> • Updated the package outline drawings; however, no technical changes. • Replaced the package term VFQFN with VFQFPN.
November 11, 2015	<p>Section , "Pin Assignment" - updated Pin Assignment format.</p> <p>Section , "Parameter Measurement Information, continued" - changed MUX Isolation to Channel Isolation.</p> <p>Throughout the datasheet, deleted "IDT" prefix and "I" suffix from the part number.</p>

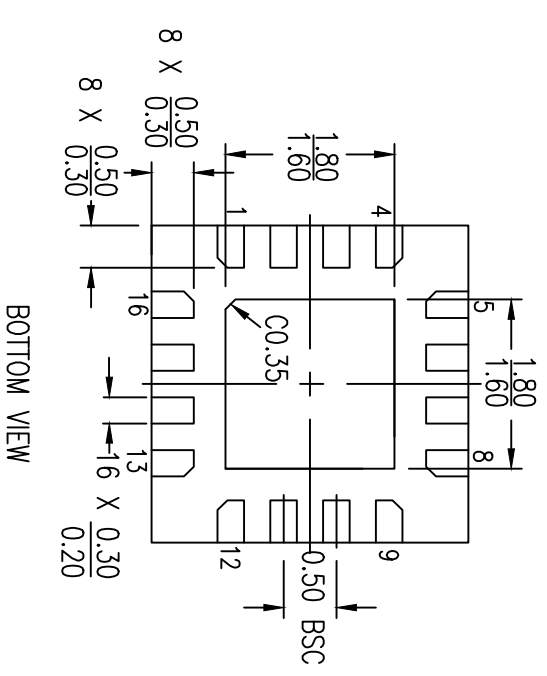
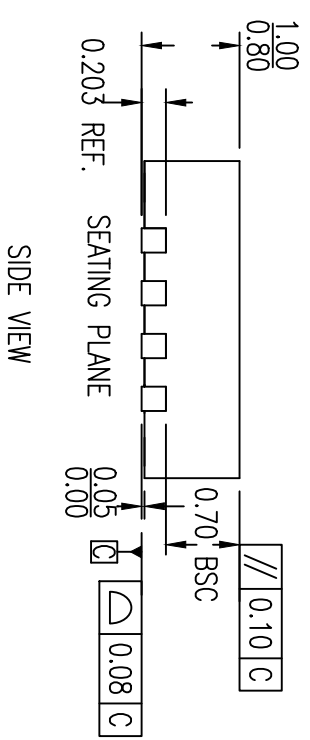
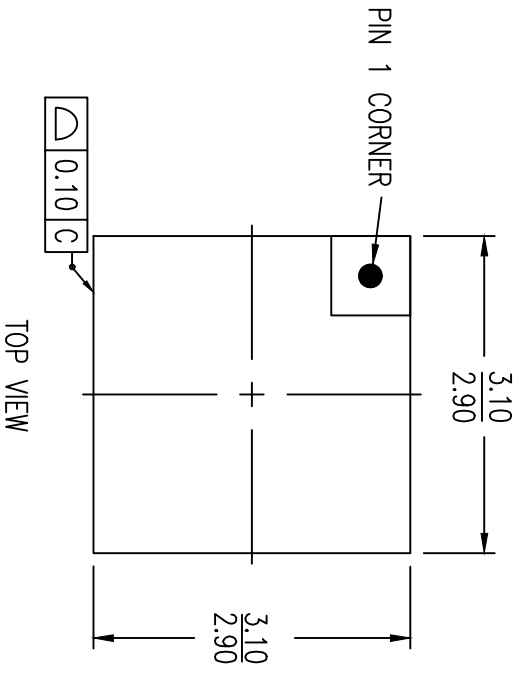

NOTES:
1. ALL DIMENSIONS ARE IN mm. ANGLES IN DEGREES

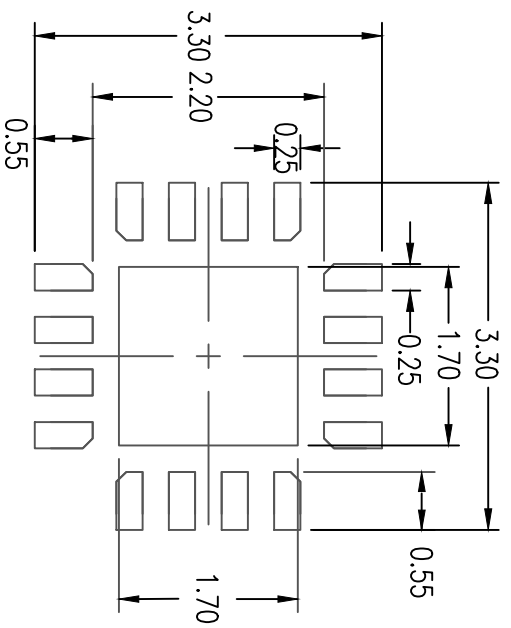

RECOMMENDED LAND PATTERN DIMENSION

NOTES:

1. ALL DIMENSIONS ARE IN mm. ANGLES IN DEGREES
2. TOP DOWN VIEW-AS VIEWED ON PCB
3. LAND PATTERN RECOMMENDATION IS PER IPC-7351B GENERIC REQUIREMENT FOR SURFACE MOUNT DESIGN AND LAND PATTERN

Package Revision History

Date Created	Rev No.	Description
Oct 25, 2017	Rev 04	Remove Bookmak at Pdf Format & Update Thickness Tolerance
Jan 18, 2018	Rev 05	Change QFN to VFQFPN

IMPORTANT NOTICE AND DISCLAIMER

RENESAS ELECTRONICS CORPORATION AND ITS SUBSIDIARIES (“RENESAS”) PROVIDES TECHNICAL SPECIFICATIONS AND RELIABILITY DATA (INCLUDING DATASHEETS), DESIGN RESOURCES (INCLUDING REFERENCE DESIGNS), APPLICATION OR OTHER DESIGN ADVICE, WEB TOOLS, SAFETY INFORMATION, AND OTHER RESOURCES “AS IS” AND WITH ALL FAULTS, AND DISCLAIMS ALL WARRANTIES, EXPRESS OR IMPLIED, INCLUDING, WITHOUT LIMITATION, ANY IMPLIED WARRANTIES OF MERCHANTABILITY, FITNESS FOR A PARTICULAR PURPOSE, OR NON-INFRINGEMENT OF THIRD-PARTY INTELLECTUAL PROPERTY RIGHTS.

These resources are intended for developers who are designing with Renesas products. You are solely responsible for (1) selecting the appropriate products for your application, (2) designing, validating, and testing your application, and (3) ensuring your application meets applicable standards, and any other safety, security, or other requirements. These resources are subject to change without notice. Renesas grants you permission to use these resources only to develop an application that uses Renesas products. Other reproduction or use of these resources is strictly prohibited. No license is granted to any other Renesas intellectual property or to any third-party intellectual property. Renesas disclaims responsibility for, and you will fully indemnify Renesas and its representatives against, any claims, damages, costs, losses, or liabilities arising from your use of these resources. Renesas' products are provided only subject to Renesas' Terms and Conditions of Sale or other applicable terms agreed to in writing. No use of any Renesas resources expands or otherwise alters any applicable warranties or warranty disclaimers for these products.

(Disclaimer Rev.1.01 Jan 2024)

Corporate Headquarters

TOYOSU FORESIA, 3-2-24 Toyosu,
Koto-ku, Tokyo 135-0061, Japan
www.renesas.com

Trademarks

Renesas and the Renesas logo are trademarks of Renesas Electronics Corporation. All trademarks and registered trademarks are the property of their respective owners.

Contact Information

For further information on a product, technology, the most up-to-date version of a document, or your nearest sales office, please visit www.renesas.com/contact-us/.

Looking for pricing, stock, or lifecycle information?

Click below to explore more details on WIN SOURCE:

-  [View 8SLVD2102NLGI on WIN SOURCE](#)
-  [Renesas Electronics America](#) Information

Optimize Your Supply Chain with WIN SOURCE Solutions

-  Global Sourcing Solution
-  Obsolete Management
-  Cost Control Management
-  Shortage Management
-  Alternative Solution
-  Excess Inventory Management