



**THE DATASHEET OF
GMC04X5R106M10NT**



MULTILAYER CERAMIC CHIP CAPACITORS

- GMC SERIES -

APPLICATIONS

- Can be used on surface mount assembly equipment
- Our fully integrated manufacturing and total quality control systems ensure unprecedented high standards of quality and reliability.

FEATURES

- Large capacitance values in small sizes
- Excellent high frequency characteristics

CHIP CAPACITOR SELECTION

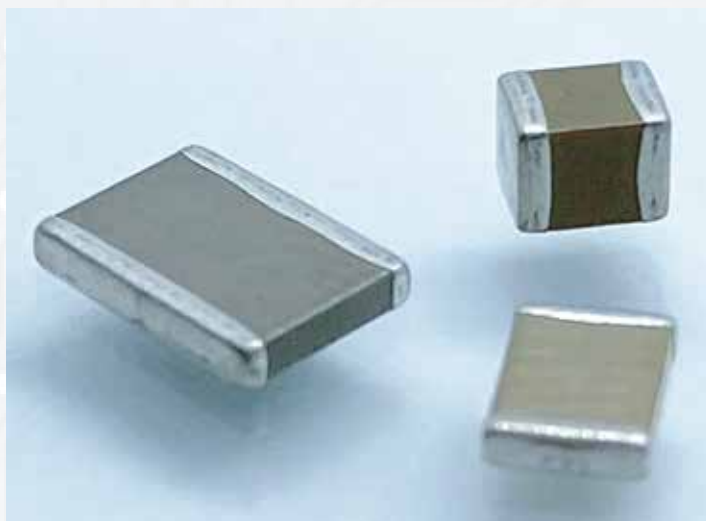

DIELECTRIC TYPE

COG (NPO) - Capacitance change with temperature is 0-30ppm/°C which is less than -0.3%/°C from -55°C to +125°C. Typical capacitance change with life is less than -0.1 % for NPOs, one-fifth that shown by most other dielectrics. NPO formulations show no aging characteristics.

Ultra stable class I dielectric: linear temperature coefficient, low loss, negligible change of electrical properties with time, voltage and frequency.

OPERATING TEMPERATURE RANGE	TEMPERATURE COEFFICIENT	DISSIPATION FACTOR	INSULATION RESISTANCE	DIELECTRIC WITHSTANDING VOLTAGE	AGING RATE	TEST PARAMETERS
-55°C to +125 C	0±30ppm°C	0.1% Max, 0.02% Typical	•>100GΩ or 1000ΩF •125°C VDCW: 10GΩF or 100ΩF whichever is less	3 X VDCW	0% per decade hour	• C<1000pF f=1MHz V=1.0Vrms ±0.2Vrms T=25°C • C>1000pF f=1KHz V=1.0Vrms ±0.2Vrms T=25°C

Stable class II dielectric

OPERATING TEMPERATURE RANGE	TEMPERATURE COEFFICIENT	DISSIPATION FACTOR	INSULATION RESISTANCE	DIELECTRIC WITHSTANDING VOLTAGE	AGING RATE	TEST PARAMETERS
X7R: -55C to+125C X5R: -55C to+85C X6S: -55C to+105C X7S: -55C to+125C	± 15% ± 15% ± 22% ± 22%	2.5% Max, 1.8% Typical	•25°C, VdCW: >100GΩF or 1000ΩF, whichever is less •125°C, VdCW: >100GΩF or1000ΩF whichever is less	2.5 X VDCW	<2% per decade hour	• 1KHz 1.0Vrms +/-0.2Vrms 25c Values > or = to 10µF 0.5+/-0.1 VDCW @120Hz

Z5U - Despite their capacitance instability, Z5U formulations are very popular because of their small size, temperature range low ESL, low ESR and excellent frequency response. These features are particularly important for decoupling application where only a minimum capacitance value is required.

Y5V - Y5V formulations are for general purpose use in a limited temperature range. They have a wide temperature characteristic of +22% - 82% capacitance change over the operating temperature range of -30°C to +85°C. Y5Vs high dielectric constant allows the manufacture of very high capacitance values (up to 100µF) in small physical sizes.

High capacitance per unit volume: general purpose product

OPERATING TEMPERATURE RANGE	TEMPERATURE COEFFICIENT	TEMPERATURE VOLTAGE COEFFICIENT (Δc MAX @ VdCW)	DISSIPATION FACTOR	INSULATION RESISTANCE	DIELECTRIC WITHSTANDING VOLTAGE	AGING RATE	TEST PARAMETERS
-30°C to +85°C	+22% -82%	N/A	3.0% Max, 2.0% Typical	•10GΩ or 100ΩF whichever is less, 25°C, VdCW	2.5 X VdCW	3.0% per decade hour	• 1 KHz, 1 Vrms 25°C values > or = to 10uF 1.0Vrms 120Hz

CONSTRUCTION

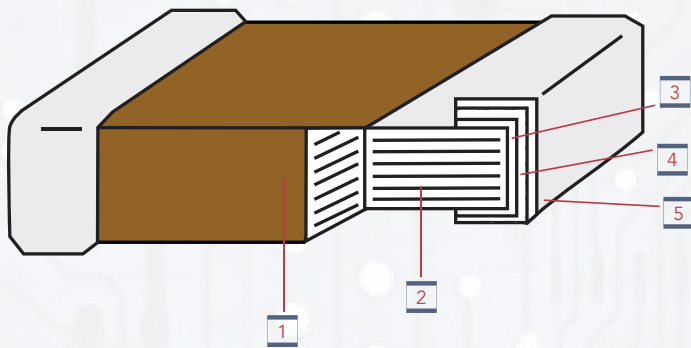

NO.	NAME	CLASS I DIELECTRIC	CLASS II DIELECTRIC
1	Ceramic Material	CaZrO ₃	BaTiO ₃
2	Inner Electrode	Ni	Ni
3	Inner layer	Cu	Cu
4	Termination Middle layer	Ni	Ni
5	Termination Outer layer	Sn	Sn

CAPACITANCE VALUE & TOLERANCE

Determined by circuit requirements. Note that chip prices decrease with lower capacitance value and looser tolerance.

CAPACITOR SIZE

Select the smallest unit permitted by the circuit constraints that provides the required capacitance and voltage rating. All Cal-Chip capacitors conform to EIA specifications.

VOLTAGE

Determined by circuit requirements.

CAPACITOR TERMINATION

Nickel barrier is standard and recommended for units exposed to repeated solder cycles, to minimize leaching of the termination.

REFLOW SOLDERING CONDITIONS

The lead-free termination MLCCs are not only to be used on SMT against lead-free solder paste, but also suitable against lead-containing solder paste. If the optimized solder joint is requested, increasing soldering time, temperature and concentration of N₂ within oven are recommended.

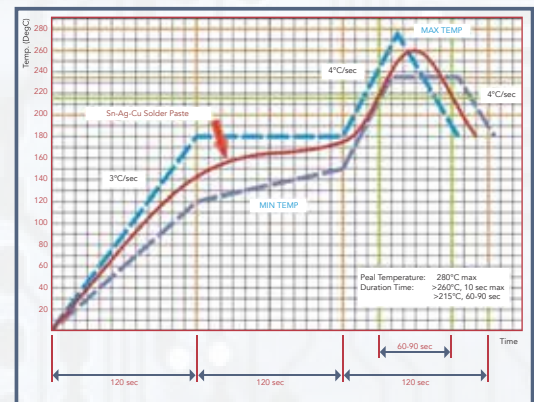

PART NUMBER GUIDE

GMC	21	CG	102	J	50	NT	D
PRODUCT TYPE	DIMENSIONS	DIELECTRIC	CAPACITANCE	TOLERANCE	VOLTAGE DC	TERMINATION	PACKAGING CODE
	01: 1005 32: 1210 02: 0201 40: 1808 04: 0402 43: 1812 10: 0603 45: 1825 21: 0805 55: 2220 31: 1206 57: 2225	CG: COG/NPO X7R X5R X7S X6S Y5V Z5U	0R5: 0.5pF 5R0: 5.0pF R75: 0.75pF 100: 10pF 101: 100pF 102: 1000pF 103: .01uF 104: .1uF 105: 1.0uF 106: 10uF 107: 100uF	B: +/-1pF C: +/-25pF D: +/-5pF F: +/-1% G: +/-2% J: +/-5% K: +/-10% M: +/-20% Z: -20%/+80%	4R0: 4.0V 6R3: 6.3V 10: 10V 16: 16V 25: 25V 35: 35V 50: 50V 63: 63V 100: 100V 200: 200V	NT: Sn/Ni PT: Pd/Ag	Blank: 7" reel D: See page 19 & 20 G: See page 19 & 20 Q: See page 19 & 20



DIMENSION (MM)		NPO/COG																													
		GMC01				GMC02				GMC04				GMC10				GMC21				GMC31									
L		0.4 ± 0.02				0.6 ± 0.03				1.0 ± 0.05				1.6 ± 0.2				2.0 ± 0.3				3.2 ± 0.3									
W		0.2 ± 0.02				0.3 ± 0.03				0.5 ± 0.05				0.8 ± 0.2				1.25 ± 0.2				1.6 ± 0.2									
BW		0.07 ~ 0.14				0.15 ± 0.05				0.1 ~ 0.35				0.1 ~ 0.4				0.25 ~ 0.75				0.25 ~ 0.75									
RATED VOLTAGE		6.3	10	16	25	50	16	25	50	100	6.3	10	16	25	50	100	200	25	50	100	200	10	16	25	50	100	200	25	50	100	200
CAP. RANGE																															
0.1pF	R10						C	C	C	C	H	H	H	H	H																
0.2	R20	A	A	A	A		C	C	C	C	H	H	H	H	H																
0.3	R30	A	A	A	A	A	C	C	C	C	H	H	H	H	H																
0.4	R40	A	A	A	A	A	C	C	C	C	H	H	H	H	H	H	L	L	L		J	J	J	J	J	J					
0.47	R47						C	C	C	C	H	H	H	H	H	H	L	L	L		J	J	J	J	J	J	L	L			
0.5	0R5	A	A	A	A	A	C	C	C	C	H	H	H	H	H	H	L	L	L	L	J	J	J	J	J	J	L	L	L	L	
0.56	R56						C	C	C	C	H	H	H	H	H	H	L	L	L		J	J	J	J	J	J	L	L			
0.6	0R6	A	A	A	A		C	C	C	C	H	H	H	H	H	H	L	L	L		J	J	J	J	J	J	L	L	L	L	
0.68	R68										H	H	H	H	H	H	L	L	L		J	J	J	J	J	J	L	L			
0.7	0R7	A	A	A	A		C	C	C	C	H	H	H	H	H	H	L	L	L		J	J	J	J	J	J	L	L	L	L	
0.75	R75	A	A	A	A		C	C	C	C	H	H	H	H	H	H	L	L	L		J	J	J	J	J	J	L	L	L	L	
0.8	0R8	A	A	A	A		C	C	C	C	H	H	H	H	H	H	L	L	L		J	J	J	J	J	J	L	L	L	L	
0.82	R82						C	C	C	C	H	H	H	H	H	H	L	L	L		J	J	J	J	J	J					
0.9	0R9	A	A	A	A		C	C	C	C	H	H	H	H	H	H	L	L	L		J	J	J	J	J	J	L	L	L	L	
1	1R0	A	A	A	A		C	C	C	C	H	H	H	H	H	H	H	L	L	L	L	J	J	J	J	J	J	L	L	L	L
1.1	1R1	A	A	A	A	A	C	C	C	C	H	H	H	H	H	H					J	J	J	J	J	J	L	L	L	L	
1.2	1R2	A	A	A	A		C	C	C	C	H	H	H	H	H	H	H	L	L	L	L	J	J	J	J	J	J	L	L	L	L
1.3	1R3	A	A	A	A		C	C	C	C	H	H	H	H	H	H					J	J	J	J	J	J	L	L	L	L	
1.4	1R4	A	A	A	A		C	C	C	C	H	H	H	H	H	H					J	J	J	J	J	J					
1.5	1R5	A	A	A	A	A	C	C	C	C	H	H	H	H	H	H	L	L	L	L	J	J	J	J	J	J	L	L	L	L	
1.6	1R6	A	A	A	A		C	C	C	C	H	H	H	H	H	H	L	L	L	L	J	J	J	J	J	J	L	L	L	L	
1.7	1R7	A	A	A	A		C	C	C	C	H	H	H	H	H	H															
1.8	1R8	A	A	A	A		C	C	C	C	H	H	H	H	H	H	L	L	L	L	J	J	J	J	J	J	L	L	L	L	
1.9	1R9	A	A	A	A		C	C	C	C	H	H	H	H	H	H															
2	2R0	A	A	A	A		C	C	C	C	H	H	H	H	H	H	L	L	L	L	J	J	J	J	J	J	L	L	L	L	
2.1	2R1	A	A	A	A		C	C	C	C	H	H	H	H	H	H															
2.2	2R2	A	A	A	A		C	C	C	C	H	H	H	H	H	H	H	L	L	L	L	J	J	J	J	J	J	L	L	L	L
2.3	2R3	A	A	A	A		C	C	C	C	H	H	H	H	H	H															
2.4	2R4	A	A	A	A		C	C	C	C	H	H	H	H	H	H	L	L	L	L	J	J	J	J	J	J	L	L	L	L	
2.5	2R5	A	A	A	A		C	C	C	C	H	H	H	H	H	H															
2.6	2R6	A	A	A	A		C	C	C	C	H	H	H	H	H	H															
2.7	2R7	A	A	A	A	A	C	C	C	C	H	H	H	H	H	H	L	L	L	L	J	J	J	J	J	J	L	L	L	L	
2.8	2R8	A	A	A	A		C	C	C	C	H	H	H	H	H	H															
2.9	2R9	A	A	A	A		C	C	C	C	H	H	H	H	H	H															
3	3R0	A	A	A	A	A	C	C	C	C	H	H	H	H	H	H	L	L	L	L	J	J	J	J	J	J	L	L	L	L	
3.1	3R1	A	A	A	A		C	C	C	C	H	H	H	H	H	H															
3.2	3R2	A	A	A	A		C	C	C	C	H	H	H	H	H	H															
3.3	3R3	A	A	A	A	A	C	C	C	C	H	H	H	H	H	H	H	L	L	L	L	J	J	J	J	J	J	L	L	L	L
3.4	3R4	A	A	A	A		C	C	C	C	H	H	H	H	H	H															
3.5	3R5	A	A	A	A		C	C	C	C	H	H	H	H	H	H															
3.6	3R6	A	A	A	A	A	C	C	C	C	H	H	H	H	H	H	L	L	L	L	J	J	J	J	J	J	L	L	L	L	
3.7	3R7	A	A	A	A		C	C	C	C	H	H	H	H	H	H															
3.8	3R8	A	A	A	A		C	C	C	C	H	H	H	H	H	H															
3.9	3R9	A	A	A	A	A	C	C	C	C	H	H	H	H	H	H	L	L	L	L	J	J	J	J	J	J	L	L	L	L	
4	4R0	A	A	A	A		C	C	C	C	H	H	H	H	H	H	L	L	L	L	J	J	J	J	J	J	L	L	L	L	
4.1	4R1	A	A	A	A		C	C	C	C	H	H	H	H	H	H															
4.2	4R2	A	A	A	A		C	C	C	C	H	H	H	H	H	H															
4.3	4R3	A	A	A	A		C	C	C	C	H	H	H	H	H	H	L	L	L	L	J	J	J	J	J	J	L	L	L	L	
4.4	4R4	A	A	A	A		C	C	C	C	H	H	H	H	H	H															
4.5	4R5	A	A	A	A		C	C	C	C	H	H	H	H	H	H															

MAX HEIGHT				
A	C	H	J	L
0.22	0.33	0.55	0.7	0.90

		NPO/COG																													
DIMENSION (MM)		GMC01				GMC02				GMC04						GMC10				GMC21						GMC31					
L		0.4 ± 0.02				0.6 ± 0.03				1.0 ± 0.05						1.6 ± 0.2				2.0 ± 0.3						3.2 ± 0.3					
W		0.2 ± 0.02				0.3 ± 0.03				0.5 ± 0.05						0.8 ± 0.2				1.25 ± 0.2						1.6 ± 0.2					
BW		0.07 ~ 0.14				0.15 ± 0.05				0.1 ~ 0.35						0.1 ~ 0.4				0.25 ~ 0.75						0.25 ~ 0.75					
RATED VOLTAGE		6.3	10	16	25	50	16	25	50	100	6.3	10	16	25	50	100	200	25	50	100	200	10	16	25	50	100	200	25	50	100	200
CAP. RANGE																															
4.6pF	4R6	A	A	A	A	C	C	C	C	H	H	H	H	H	H	H	L	L	L	L											
4.7	4R7	A	A	A	A	A	C	C	C	C	H	H	H	H	H	H	L	L	L	L	J	J	J	J	J	J	L	L	L	L	
4.8	4R8	A	A	A	A	C	C	C	C	H	H	H	H	H	H	L	L	L	L												
4.9	4R9	A	A	A	A	C	C	C	C	H	H	H	H	H	H	L	L	L	L	J	J	J	J	J	J						
5	5R0	A	A	A	A	C	C	C	C	H	H	H	H	H	H	L	L	L	L	J	J	J	J	J	J	L	L	L	L		
5.1	5R1	A	A	A	A	C	C	C	C	H	H	H	H	H	H	L	L	L	L	J	J	J	J	J	J	L	L	L	L		
5.2	5R2	A	A	A	A	C	C	C	C	H	H	H	H	H	H	L	L	L	L												
5.3	5R3	A	A	A	A	C	C	C	C	H	H	H	H	H	H	L	L	L	L	J	J	J	J	J	J						
5.4	5R4	A	A	A	A	C	C	C	C	H	H	H	H	H	H	L	L	L	L	J	J	J	J	J	J						
5.5	5R5	A	A	A	A	C	C	C	C	H	H	H	H	H	H	L	L	L	L	J	J	J	J	J	J						
5.6	5R6	A	A	A	A	A	C	C	C	C	H	H	H	H	H	H	H	L	L	L	L	J	J	J	J	J	J	L	L	L	L
5.7	5R7	A	A	A	A	C	C	C	C	H	H	H	H	H	H	L	L	L	L	J	J	J	J	J	J						
5.8	5R8	A	A	A	A	C	C	C	C	H	H	H	H	H	H	L	L	L	L												
5.9	5R9	A	A	A	A	C	C	C	C	H	H	H	H	H	H	L	L	L	L	J	J	J	J	J	J						
6	6R0	A	A	A	A	C	C	C	C	H	H	H	H	H	H	L	L	L	L	J	J	J	J	J	J	L	L	L	L		
6.1	6R1	A	A	A	A	C	C	C	C	H	H	H	H	H	H	L	L	L	L	J	J	J	J	J	J						
6.2	6R2	A	A	A	A	C	C	C	C	H	H	H	H	H	H	H	L	L	L	L	J	J	J	J	J	J	L	L	L	L	
6.3	6R3	A	A	A	A	C	C	C	C	H	H	H	H	H	H	L	L	L	L	J	J	J	J	J	J						
6.4	6R4	A	A	A	A	C	C	C	C	H	H	H	H	H	H	L	L	L	L												
6.5	6R5	A	A	A	A	C	C	C	C	H	H	H	H	H	H	L	L	L	L	J	J	J	J	J	J						
6.6	6R6	A	A	A	A	C	C	C	C	H	H	H	H	H	H	L	L	L	L												
6.7	6R7	A	A	A	A	C	C	C	C	H	H	H	H	H	H	L	L	L	L	J	J	J	J	J	J						
6.8	6R8	A	A	A	A	A	C	C	C	C	H	H	H	H	H	H	L	L	L	L	J	J	J	J	J	J	L	L	L	L	
6.9	6R9	A	A	A	A	C	C	C	C	H	H	H	H	H	H	L	L	L	L												
7	7R0	A	A	A	A	A	C	C	C	C	H	H	H	H	H	H	L	L	L	L	J	J	J	J	J	J	L	L	L	L	
7.1	7R1	A	A	A	A	C	C	C	C	H	H	H	H	H	H	L	L	L	L												
7.2	7R2	A	A	A	A	C	C	C	C	H	H	H	H	H	H	L	L	L	L	J	J	J	J	J	J						
7.3	7R3	A	A	A	A	C	C	C	C	H	H	H	H	H	H	L	L	L	L												
7.4	7R4	A	A	A	A	C	C	C	C	H	H	H	H	H	H	L	L	L	L	J	J	J	J	J	J						
7.5	7R5	A	A	A	A	C	C	C	C	H	H	H	H	H	H	L	L	L	L	J	J	J	J	J	J	L	L	L	L		
7.6	7R6	A	A	A	A	C	C	C	C	H	H	H	H	H	H	L	L	L	L	J	J	J	J	J	J						
7.7	7R7	A	A	A	A	C	C	C	C	H	H	H	H	H	H	L	L	L	L							L	L	L	L		
7.8	7R8	A	A	A	A	C	C	C	C	H	H	H	H	H	H	L	L	L	L	J	J	J	J	J	J						
7.9	7R9	A	A	A	A	C	C	C	C	H	H	H	H	H	H	L	L	L	L												
8	8R0	A	A	A	A	A	C	C	C	C	H	H	H	H	H	H	L	L	L	L	J	J	J	J	J	J	L	L	L	L	
8.1	8R1	A	A	A	A	C	C	C	C	H	H	H	H	H	H	L	L	L	L	J	J	J	J	J	J						
8.2	8R2	A	A	A	A	A	C	C	C	C	H	H	H	H	H	H	H	L	L	L	L	J	J	J	J	J	J	L	L	L	L
8.3	8R3	A	A	A	A	C	C	C	C	H	H	H	H	H	H	L	L	L	L	J	J	J	J	J	J						
8.3	8R3	A	A	A	A	C	C	C	C	H	H	H	H	H	H	L	L	L	L	J	J	J	J	J	J						
8.4	8R4	A	A	A	A	C	C	C	C	H	H	H	H	H	H	L	L	L	L												
8.5	8R5	A	A	A	A	C	C	C	C	H	H	H	H	H	H	L	L	L	L	J	J	J	J	J	J						
8.6	8R6	A	A	A	A	C	C	C	C	H	H	H	H	H	H	L	L	L	L												
8.7	8R7	A	A	A	A	C	C	C	C	H	H	H	H	H	H	L	L	L	L	J	J	J	J	J	J						
8.8	8R8	A	A	A	A	C	C	C	C	H	H	H	H	H	H	L	L	L	L												
8.9	8R9	A	A	A	A	C	C	C	C	H	H	H	H	H	H	L	L	L	L	J	J	J	J	J	J						
9	9R0	A	A	A	A	C	C	C	C	H	H	H	H	H	H	L	L	L	L	J	J	J	J	J	J	L	L	L	L		
9.1	9R1	A	A	A	A	C	C	C	C	H	H	H	H	H	H	L	L	L	L	J	J	J	J	J	J	L	L	L	L		
9.2	9R2	A	A	A	A	C	C	C	C	H	H	H	H	H	H	L	L	L	L												
9.3	9R3	A	A	A	A	C	C	C	C	H	H	H	H	H	H	L	L	L	L	J	J	J	J	J	J						
9.4	9R4	A	A	A	A	C	C	C	C	H	H	H	H	H	H	L	L	L	L												
9.5	9R5	A	A	A	A	C	C	C	C	H	H	H	H	H	H	L	L	L	L	J	J	J	J	J	J						
9.6	9R6	A	A	A	A	C	C	C	C	H	H	H	H	H	H	L	L	L	L												
9.7	9R7	A	A	A	A	C	C	C	C	H	H	H	H	H	H	L	L	L	L	J	J	J	J	J	J						

MAX HEIGHT				
A	C	H	J	L
0.22	0.33	0.55	0.7	0.90

DIELECTRIC		NPO/COG																													
DIMENSION (MM)		GMC01					GMC02				GMC04					GMC10				GMC21					GMC31						
L		0.4 ± 0.02					0.6 ± 0.03				1.0 ± 0.05					1.6 ± 0.2				2.0 ± 0.3					3.2 ± 0.3						
W		0.2 ± 0.02					0.3 ± 0.03				0.5 ± 0.05					0.8 ± 0.2				1.25 ± 0.2					1.6 ± 0.2						
BW		0.07 ~ 0.14					0.15 ± 0.05				0.1 ~ 0.35					0.1 ~ 0.4				0.25 ~ 0.75					0.25 ~ 0.75						
RATED VOLTAGE		6.3	10	16	25	50	16	25	50	100	6.3	10	16	25	50	100	200	25	50	100	200	10	16	25	50	100	200	25	50	100	200
CAP. RANGE																															
9.8pF	9R8	A	A	A	A		C	C	C	C	H	H	H	H	H	H		L	L	L	L										
9.9	9R9	A	A	A	A		C	C	C	C	H	H	H	H	H	H		L	L	L	L										
10	100	A	A	A	A	A	C	C	C	C	H	H	H	H	H	H	H	L	L	L	L	J	J	J	J	J	J	L	L	L	L
11	110	A	A	A	A	A	C	C	C		H	H	H	H	H			L	L	L	L	J	J	J	J	J	J	L	L	L	L
12	120	A	A	A	A	A	C	C	C	C	H	H	H	H	H			L	L	L	L	J	J	J	J	J	J	L	L	L	L
13	130	A	A	A	A	A	C	C	C		H	H	H	H	H			L	L	L	L	J	J	J	J	J	J	L	L	L	L
15	150	A	A	A	A	A	C	C	C	C	H	H	H	H	H	H		L	L	L	L	J	J	J	J	J	J	L	L	L	L
16	160	A	A	A	A		C	C	C		H	H	H	H	H			L	L	L	L	J	J	J	J	J	J	L	L	L	L
18	180	A	A	A	A		C	C	C		H	H	H	H	H	H		L	L	L	L	J	J	J	J	J	J	L	L	L	L
20	200	A	A	A	A		C	C	C		H	H	H	H	H	H		L	L	L	L	J	J	J	J	J	J	L	L	L	L
22	220	A	A	A	A		C	C	C		H	H	H	H	H	H		L	L	L	L	J	J	J	J	J	J	L	L	L	L
23	230										H	H	H	H	H																
24	240	A	A	A	A		C	C	C		H	H	H	H	H			L	L	L	L	J	J	J	J	J	J	L	L	L	L
25	250										H	H	H	H	H																
27	270	A	A	A	A		C	C	C		H	H	H	H	H	H		L	L	L	L	J	J	J	J	J	J	L	L	L	L
30	300	A	A	A	A		C	C	C	C	H	H	H	H	H	H		L	L	L	L	J	J	J	J	J	J	L	L	L	L
33	330	A	A	A	A		C	C	C		H	H	H	H	H	H		L	L	L	L	J	J	J	J	J	J	L	L	L	L
36	360	A	A	A	A		C	C	C		H	H	H	H	H	H		L	L	L	L	J	J	J	J	J	J	L	L	L	L
38	380										H	H	H	H	H																
39	390	A	A	A	A		C	C	C		H	H	H	H	H	H		L	L	L	L	J	J	J	J	J	J	L	L	L	L
40	400										H	H	H	H	H			L	L	L											
42	420										H	H	H	H	H																
43	430	A	A	A	A	A	C	C	C		H	H	H	H	H	H		L	L	L	L	J	J	J	J	J	J	L	L	L	L
47	470	A	A	A	A		C	C	C		H	H	H	H	H	H		L	L	L	L	J	J	J	J	J	J	L	L	L	L
50	500										H	H	H	H	H	H		L	L	L											
51	510	A	A	A	A		C	C	C		H	H	H	H	H	H		L	L	L	L	J	J	J	J	J	J	L	L	L	L
53	530																	L	L	L											
56	560	A	A	A	A		C	C	C		H	H	H	H	H	H		L	L	L	L	J	J	J	J	J	J	L	L	L	L
60	600										H	H	H	H	H			L	L	L											
62	620	A	A	A	A	A	C	C	C		H	H	H	H	H	H		L	L	L	L	J	J	J	J	J	J	L	L	L	L
68	680	A	A	A	A	A	C	C	C		H	H	H	H	H	H		L	L	L	L	J	J	J	J	J	J	L	L	L	L
70	700																	L	L	L											
75	750	A	A	A	A		C	C	C		H	H	H	H	H	H		L	L	L	L	J	J	J	J	J	J	L	L	L	L
80	800										H	H	H	H	H			L	L	L											
82	820	A	A	A	A	A	C	C	C		H	H	H	H	H	H		L	L	L	L	J	J	J	J	J	J	L	L	L	L
91	910	A	A	A	A		C	C	C		H	H	H	H	H	H		L	L	L	L	J	J	J	J	J	J	L	L	L	L
100	101	A	A	A	A	A	C	C	C	C	H	H	H	H	H	H	H	L	L	L	L	J	J	J	J	J	J	R	R	R	R
110	111						C	C	C		H	H	H	H	H	H	H	L	L	L											
120	121						C	C	C		H	H	H	H	H	H		L	L	L	L	J	J	J	J	J	J	L	L	L	L
130	131						C	C	C		H	H	H	H	H			L	L	L		J	J	J	J	J	J	L	L	L	L
150	151						C	C	C		H	H	H	H	H	H		L	L	L	L	J	J	J	J	J	J	L	L	L	L
160	161										H	H	H	H	H			L	L	L		J	J	J	J	J	J	L	L	L	L
180	181						C	C	C		H	H	H	H	H	H		L	L	L	L	J	J	J	J	J	J	L	L	L	L
200	201						C	C	C		H	H	H	H	H			L	L	L		J	J	J	J	J	J	L	L	L	L
220	221		A	A	A		C	C	C		H	H	H	H	H	H		L	L	L	L	J	J	J	J	J	J	L	L	L	L
240	241		A	A	A		C	C	C		H	H	H	H	H	H		L	L	L	L	J	J	J	J	J	J	L	L	L	L
250	251																	L	L	L											
270	271		A	A	A		C	C	C		H	H	H	H	H	H		L	L	L	L	J	J	J	J	J	J	L	L	L	L
300	301						C	C	C		H	H	H	H	H			L	L	L	L	J	J	J	J	J	J	L	L	L	L
330	331		A	A	A		C	C	C		H	H	H	H	H	H	H	L	L	L	L	J	J	J	J	J	J	L	L	L	L
360	361						C	C	C		H	H	H	H	H			L	L	L	L	J	J	J	J	J	J	L	L	L	L
390	391						C	C	C		H	H	H	H	H	H		L	L	L	L	M	M	M	M	M	M	L	L	L	L
430	431						C	C	C		H	H	H	H	H			L	L	L		M	M	M	M	M	M	L	L	L	L
470	471						C	C	C		H	H	H	H	H	H		L	L	L	L	M	M	M	M	M	M	L	L	L	L

MAX HEIGHT					
A	C	H	J	L	R
0.22	0.33	0.55	0.7	0.90	1.45

NPO/COG

		NPO/COG																																					
DIMENSION (MM)		GMC01				GMC02				GMC04								GMC10				GMC21				GMC31													
L		0.4 ± 0.02				0.6 ± 0.03				1.0 ± 0.05								1.6 ± 0.2				2.0 ± 0.3				3.2 ± 0.3													
W		0.2 ± 0.02				0.3 ± 0.03				0.5 ± 0.05								0.8 ± 0.2				1.25 ± 0.2				1.6 ± 0.2													
BW		0.07 ~ 0.14				0.15 ± 0.05				0.1 ~ 0.35								0.1 ~ 0.4				0.25 ~ 0.75				0.25 ~ 0.75													
RATED VOLTAGE		6.3	25	16	25	50	25	50	6.3	10	16	25	50	100	200	25	50	100	200	16	25	50	100	200	25	50	100	200											
CAP. RANGE																																							
500pF	501																																						
510	511						C				H	H	H	H	H	H							L	L	L	L	M	M	M	M					L	L	L	L	
560	561						C				H	H	H	H	H	H							L	L	L	L	M	M	M	M	M					L	L	L	L
620	621						C				H	H	H	H	H	H							L	L	L	L	M	M	M	M	M					L	L	L	L
680	681						C				H	H	H	H	H	H							L	L	L	L	M	M	M	M	M					L	L	L	L
750	751						C				H	H	H	H	H	H							L	L	L		M	M	M	M	M					L	L	L	L
820	821						C				H	H	H	H	H	H							L	L	L	L	M	M	M	M	M					L	L	L	L
910	911						C				H	H	H	H	H	H							L	L	L	L	M	M	M	M	M					L	L	L	L
1000	102						C				H	H	H	H	H	H							L	L	L	L	M	M	M	M	M					L	L	L	L
1100	112										H	H	H	H	H								L	L	L		M	M	M	M	M								
1200	122										H	H	H	H	H								M	M	M	M	M	M	M	M	M					L	L	L	L
1300	132										H	H	H	H	H								M	M	M		M	M	M	M	M								
1500	152										H	H	H	H	H								M	M	M	M	M	M	M	M	M					L	L	L	L
1600	162										H	H	H	H									M	M	M														
1800	182										H	H	H	H									M	M	M	M	M	M	M	M	M					L	L	L	L
2000	202										H	H	H	H									M	M	M		M	M	M	M	M								
2200	222										H	H	H	H									M	M	M	M	R	R	R	R	R					L	L	L	L
2400	242																						M	M	M		R	R	R	R	R					L	L	L	L
2700	272										H	H	H	H									M	M	M		R	R	R	R	R					L	L	L	L
3000	302																						M	M			R	R	R	R	R					M	M	M	M
3300	332										H	H	H	H									M	M	M		R	R	R	R	R					M	M	M	M
3600	362																																						
3900	392																						M	M	M		R	R	R	R	R					M	M	M	M
4300	432																																						
4700	472										I	I	I	I	I								M	M	M		R	R	R	R	R					M	M	M	M
5600	562										I	I	I	I	I								M	M	M		R	R	R	R	R					M	M	M	M
6200	622																						M	M			R	R	R										
6800	682										I	I	I	I	I								M	M	M		R	R	R	R					O	O	O		
7500	752																						M	M			R	R	R										
8200	822																						M	M	M		R	R	R	R					R	R	R		
9100	912																						M	M			R	R	R										
0.01uF	103										I	I	I	I									M	M	M		R	R	R	R					R	R	R	R	
0.012	123																						M				R	R	R						U	U	U		
0.015	153																						M				R	R	R						U	U	U		
0.018	183																										R	R	R						U	U	U		
0.02	203																										R	R											
0.022	223																										R	R	R	R					U	U	U		
0.027	273																										R	R	R						U	U	U		
0.03	303																										R	R											
0.033	333																										R	R	R	R					U	U	U		
0.039	393																																		U	U	U		
0.047	473																										R	R							U	U	U		
0.056	563																																		U	U	U		
0.068	683																																		U	U	U		
0.082	823																																		U	U	U		
0.1	104																																		U	U	U		
0.12	124																																			U	U	U	

MAX HEIGHT							
C	H	I	L	M	Q	R	U
0.33	0.55	0.65	0.90	0.95	1.40	1.45	1.90



DIELECTRIC		NPO/COG																			
DIMENSION (MM)		GMC32			GMC40			GMC43			GMC45			GMC55			GMC57				
L		3.2 ± 0.3			4.57 ± 0.25			4.5 ± 0.35			4.5 ± 0.35			5.7 ± 0.4			5.7 ± 0.4				
W		2.5 ± 0.3			2.03 ± 0.25			3.2 ± 0.3			6.3 ± 0.4			5.0 ± 0.4			6.3 ± 0.4				
BW		0.25 ~ 0.75			0.25 ~ 0.75			0.25 ~ 0.75			0.40 ~ 1.10			0.50 ~ 1.20			0.50 ~ 1.20				
RATED VOLTAGE		16	25	50	100	200	50	100	200	50	100	200	50	100	200	50	100	200	50	100	200
CAP. RANGE																					
10pF	100	R	R	R	R	R	R	R	R	V	V	V	V	V	V	V	V	V	V	V	V
11	110	R	R	R	R	R	R	R	R	V	V	V	V	V	V	V	V	V	V	V	V
12	120	R	R	R	R	R	R	R	R	V	V	V	V	V	V	V	V	V	V	V	V
13	130	R	R	R	R	R	R	R	R	V	V	V	V	V	V	V	V	V	V	V	V
15	150	R	R	R	R	R	R	R	R	V	V	V	V	V	V	V	V	V	V	V	V
16	160	R	R	R	R	R	R	R	R	V	V	V	V	V	V	V	V	V	V	V	V
18	180	R	R	R	R	R	R	R	R	V	V	V	V	V	V	V	V	V	V	V	V
20	200	R	R	R	R	R	R	R	R	V	V	V	V	V	V	V	V	V	V	V	V
22	220	R	R	R	R	R	R	R	R	V	V	V	V	V	V	V	V	V	V	V	V
24	240	R	R	R	R	R	R	R	R	V	V	V	V	V	V	V	V	V	V	V	V
27	270	R	R	R	R	R	R	R	R	V	V	V	V	V	V	V	V	V	V	V	V
30	300	R	R	R	R	R	R	R	R	V	V	V	V	V	V	V	V	V	V	V	V
33	330	R	R	R	R	R	R	R	R	V	V	V	V	V	V	V	V	V	V	V	V
36	360	R	R	R	R	R	R	R	R	V	V	V	V	V	V	V	V	V	V	V	V
39	390	R	R	R	R	R	R	R	R	V	V	V	V	V	V	V	V	V	V	V	V
43	430	R	R	R	R	R	R	R	R	V	V	V	V	V	V	V	V	V	V	V	V
47	470	R	R	R	R	R	R	R	R	V	V	V	V	V	V	V	V	V	V	V	V
51	510	R	R	R	R	R	R	R	R	V	V	V	V	V	V	V	V	V	V	V	V
56	560	R	R	R	R	R	R	R	R	V	V	V	V	V	V	V	V	V	V	V	V
62	620	R	R	R	R	R	R	R	R	V	V	V	V	V	V	V	V	V	V	V	V
68	680	R	R	R	R	R	R	R	R	V	V	V	V	V	V	V	V	V	V	V	V
75	750	R	R	R	R	R	R	R	R	V	V	V	V	V	V	V	V	V	V	V	V
82	820	R	R	R	R	R	R	R	R	V	V	V	V	V	V	V	V	V	V	V	V
91	910	R	R	R	R	R	R	R	R	V	V	V	V	V	V	V	V	V	V	V	V
100	101	R	R	R	R	R	R	R	R	V	V	V	V	V	V	V	V	V	V	V	V
120	121	R	R	R	R	R	R	R	R	V	V	V	V	V	V	V	V	V	V	V	V
130	131	R	R	R	R	R	R	R	R	V	V	V	V	V	V	V	V	V	V	V	V
150	151	R	R	R	R	R	R	R	R	V	V	V	V	V	V	V	V	V	V	V	V
160	161	R	R	R	R	R	R	R	R	V	V	V	V	V	V	V	V	V	V	V	V
180	181	R	R	R	R	R	R	R	R	V	V	V	V	V	V	V	V	V	V	V	V
200	201	R	R	R	R	R	R	R	R	V	V	V	V	V	V	V	V	V	V	V	V
220	221	R	R	R	R	R	R	R	R	V	V	V	V	V	V	V	V	V	V	V	V
240	241	R	R	R	R	R	V	V	V	V	V	V	V	V	V	V	V	V	V	V	V
270	271	R	R	R	R	R	V	V	V	V	V	V	V	V	V	V	V	V	V	V	V
300	301	R	R	R	R	R	V	V	V	V	V	V	V	V	V	V	V	V	V	V	V
330	331	R	R	R	R	R	V	V	V	V	V	V	V	V	V	V	V	V	V	V	V
360	361	R	R	R	R	R	V	V	V	V	V	V	V	V	V	V	V	V	V	V	V
390	391	R	R	R	R	R	V	V	V	V	V	V	V	V	V	V	V	V	V	V	V
430	431	R	R	R	R	R	V	V	V	V	V	V	V	V	V	V	V	V	V	V	V
470	471	R	R	R	R	R	V	V	V	V	V	V	V	V	V	V	V	V	V	V	V

MAX HEIGHT	
R	V
1.45	2.20

NPO/COG

DIELECTRIC		NPO/COG																							
DIMENSION (MM)		GMC32					GMC40			GMC43			GMC45			GMC55			GMC57						
L	W	3.2 ± 0.3					4.57 ± 0.25			4.5 ± 0.35			4.5 ± 0.35			5.7 ± 0.4			5.7 ± 0.4						
W	BW	2.5 ± 0.3					2.03 ± 0.25			3.2 ± 0.3			6.3 ± 0.4			5.0 ± 0.4			6.3 ± 0.4						
RATED VOLTAGE		16	25	50	100	200	50	100	200	50	100	200	50	100	200	50	100	200	50	100	200	50	100	200	
CAP. RANGE																									
510pF	511	R	R	R	R	R	V	V	V	V	V	V	V	V	V	V	V	V	V	V	V	V	V		
560	561	R	R	R	R	R	V	V	V	V	V	V	V	V	V	V	V	V	V	V	V	V	V		
620	621						V	V	V	V	V	V	V	V	V	V	V	V	V	V	V	V	V		
680	681	R	R	R	R	R	V	V	V	V	V	V	V	V	V	V	V	V	V	V	V	V	V		
750	751	R	R	R	R	R	V	V	V	V	V	V	V	V	V	V	V	V	V	V	V	V	V		
820	821	R	R	R	R	R	V	V	V	V	V	V	V	V	V	V	V	V	V	V	V	V	V		
910	911	R	R	R	R	R	V	V	V	V	V	V	V	V	V	V	V	V	V	V	V	V	V		
1000	102	R	R	R	R	R	V	V	V	V	V	V	V	V	V	V	V	V	V	V	V	V	V		
1100	112						V	V	V	V	V	V	V	V	V	V	V	V	V	V	V	V	V		
1200	122	R	R	R	R	R	V	V	V	V	V	V	V	V	V	V	V	V	V	V	V	V	V		
1500	152	R	R	R	R	R	V	V	V	V	V	V	V	V	V	V	V	V	V	V	V	V	V		
1800	182	R	R	R	R	R	V	V	V	V	V	V	V	V	V	V	V	V	V	V	V	V	V		
2000	202						V	V	V	V	V	V	V	V	V	V	V	V	V	V	V	V	V		
2200	222	R	R	R	R	R	V	V	V	V	V	V	V	V	V	V	V	V	V	V	V	V	V		
2400	242	R	R	R	R	R	V	V	V	V	V	V	V	V	V	V	V	V	V	V	V	V	V		
2700	272	R	R	R	R	R	V	V	V	V	V	V	V	V	V	V	V	V	V	V	V	V	V		
3000	302						V	V	V	V	V	V	V	V	V	V	V	V	V	V	V	V	V		
3300	332	R	R	R	R	R	V	V	V	V	V	V	V	V	V	V	V	V	V	V	V	V	V		
3900	392	R	R	R	R	R	V	V	V	V	V	V	V	V	V	V	V	V	V	V	V	V	V		
4700	472	R	R	R	R	R	V	V	V	V	V	V	V	V	V	V	V	V	V	V	V	V	V		
5600	562	R	R	R	R	R	V	V	V	V	V	V	V	V	V	V	V	V	V	V	V	V	V		
6800	682	R	R	R	R	R	V	V	V	V	V	V	V	V	V	V	V	V	V	V	V	V	V		
7500	752	R	R	R	R	R	V	V	V	V	V	V	V	V	V	V	V	V	V	V	V	V	V		
8200	822	R	R	R	R	R	V	V		V	V	V	V	V	V	V	V	V	V	V	V	V	V		
.01uF	103	R	R	R	R	R	V	V		V	V	V	V	V	V	V	V	V	V	V	V	V	V		
0.012	123	P	P	P	P	P	V	V		V	V	V	V	V	V	V	V	V	V	V	V	V	V		
0.015	153	P	P	P	P	P	V			V	V	V	V	V	V	V	V	V	V	V	V	V	V		
0.018	183	V	V	V	V	V	V			V	V	V	V	V	V	V	V	V	V	V	V	V	V		
0.022	223	V	V	V	V	V				V	V	V	V	V	V	V	V	V	V	V	V	V	V		
0.027	273	V	V	V	V	V				V	V	V	V	V	V	V	V	V	V	V	V	V	V		
0.033	333	V	V	V	V	V				V	V	V	V	V			V	V			V	V	V		
0.039	393	V	V	V	V	V				Y	Y	Y	V	V			V	V			V	V	V		
0.047	473	V	V	V	V	V				Y	Y	Y	V	V			V	V			V	V	V		
0.056	563	V	V	V	V					Y	Y	Y	V	V			V	V			V	V	Y		
0.068	683	V	V	V	V					Y	Y	Y	V	V			V	V			V	V	Y		
0.082	823	V	V	V	V					Y	Y	Y	V				Y	Y			V	V	Y		
0.1	104	V	V	V	V					Y	Y	Y	V				Y	Y			V	V	Y		
0.12	124									Y	Y		V				V	V			Y	Y			
0.15	154	W	W	W						Y	Y		V				V	V							
0.18	184									Y			V				V	V							
0.22	224	W	W							A2							V	V							
0.27	274																V	V							
0.33	334																V	V							
0.47	474																V								
1	105																								
2.2	225																								
4.7	475																								

MAX HEIGHT					
R	P	V	W	Y	A2
1.45	1.35	2.2	2.3	2.8	3.5





DIELECTRIC	X7R																																							
DIMENSION (MM)	GMC01				GMC02				GMC04				GMC10				GMC21				GMC31																			
L(L1)	0.4 ± 0.02				0.6 ± 0.03				1.0 ± 0.05				1.6 ± 0.2				2.0 ± 0.3				3.2 ± 0.3																			
W	0.2 ± 0.02				0.3 ± 0.03				0.5 ± 0.05				0.8 ± 0.2				1.25 ± 0.2				1.6 ± 0.2																			
BW(L2/LW)	0.07 ~ 0.14				0.15 ± 0.05				0.1 ~ 0.35				0.1 ~ 0.4				0.25 ~ 0.75				0.25 ~ 0.75																			
RATED VOLTAGE	6.3	10	16	6.3	10	16	25	50	6.3	10	16	25	35	50	100	4	6.3	10	16	25	35	50	100	200	6.3	10	16	25	35	50	100	200	6.3	10	16	25	35	50	100	200
CAP. RANGE																																								
4700pF	472				C	C	C	C		H	H	H	H	H	H	H	L	L	L	L	L	L	L	L	M	M	M	M	M	M	M	M	R	R	R	R	R	R	R	R
5600	562				C	C	C	C		H	H	H	H	H	H		L	L	L	L	L	L	L	L	M	M	M	M	M	M	M	M	R	R	R	R	R	R	R	R
6800	682				C	C	C	C		H	H	H	H	H	H		L	L	L	L	L	L	L	L	M	M	M	M	M	M	M	M	R	R	R	R	R	R	R	R
8200	822				C	C	C	C		H	H	H	H	H	H	H	L	L	L	L	L	L	L	L	M	M	M	M	M	M	M	M	R	R	R	R	R	R	R	R
0.01uF	103				C	C	C	C		H	H	H	H	H	H	H	L	L	L	L	L	L	L	L	M	M	M	M	M	M	M	M	R	R	R	R	R	R	R	R
0.012	123									H	H	H	H	H	H		L	L	L	L	L	L	L	L	M	M	M	M	M	M	M	M	R	R	R	R	R	R	R	R
0.015	153									H	H	H	H	H	H		L	L	L	L	L	L	L	L	M	M	M	M	M	M	M	M	R	R	R	R	R	R	R	R
0.018	183									H	H	H	H	H	H		L	L	L	L	L	L	L	L	M	M	M	M	M	M	M	M	R	R	R	R	R	R	R	R
0.02	203																L	L	L	L	L	L	L	L	M	M	M	M	M	M	M	M	R	R	R	R	R	R	R	R
0.022	223																L	L	L	L	L	L	L	L	M	M	M	M	M	M	M	M	R	R	R	R	R	R	R	R
0.027	273																L	L	L	L	L	L	L	L	M	M	M	M	M	M	M	M	R	R	R	R	R	R	R	R
0.033	333																M	M	M	M	M	M	M	M	M	M	M	M	M	M	M	M	M	M	M	M	M	M	M	M
0.039	393																M	M	M	M	M	M	M	M	M	M	M	M	M	M	M	M	M	M	M	M	M	M	M	M
0.047	473																M	M	M	M	M	M	M	M	M	M	M	M	M	M	M	M	M	M	M	M	M	M	M	M
0.056	563																M	M	M	M	M	M	M	M	M	M	M	M	M	M	M	M	M	M	M	M	M	M	M	M
0.068	683																M	M	M	M	M	M	M	M	M	M	M	M	M	M	M	M	M	M	M	M	M	M	M	M
0.082	823																M	M	M	M	M	M	M	M	M	M	M	M	M	M	M	M	M	M	M	M	M	M	M	M
0.1	104																M	M	M	M	M	M	M	M	M	M	M	M	M	M	M	M	M	M	M	M	M	M	M	M
0.12	124																M	M	M	M	M	M	M	M	M	M	M	M	M	M	M	M	M	M	M	M	M	M	M	M
0.15	154																M	M	M	M	M	M	M	M	M	M	M	M	M	M	M	M	M	M	M	M	M	M	M	M
0.18	184																M	M	M	M	M	M	M	M	M	M	M	M	M	M	M	M	M	M	M	M	M	M	M	M
0.22	224																M	M	M	M	M	M	M	M	M	M	M	M	M	M	M	M	M	M	M	M	M	M	M	M
0.27	274																M	M	M	M	M	M	M	M	M	M	M	M	M	M	M	M	M	M	M	M	M	M	M	M
0.33	334																M	M	M	M	M	M	M	M	M	M	M	M	M	M	M	M	M	M	M	M	M	M	M	M
0.39	394																M	M	M	M	M	M	M	M	M	M	M	M	M	M	M	M	M	M	M	M	M	M	M	M
0.47	474																M	M	M	M	M	M	M	M	M	M	M	M	M	M	M	M	M	M	M	M	M	M	M	M
0.56	564																M	M	M	M	M	M	M	M	M	M	M	M	M	M	M	M	M	M	M	M	M	M	M	M
0.68	684																M	M	M	M	M	M	M	M	M	M	M	M	M	M	M	M	M	M	M	M	M	M	M	M
0.82	824																M	M	M	M	M	M	M	M	M	M	M	M	M	M	M	M	M	M	M	M	M	M	M	M
1	105																M	M	M	M	M	M	M	M	M	M	M	M	M	M	M	M	M	M	M	M	M	M	M	
1.5	155																N	N	N	N	N	N	N	N	N	N	N	N	N	N	N	N	N	N	N	N	N	N	N	
2.2	225																N	N	N	N	N	N	N	N	N	N	N	N	N	N	N	N	N	N	N	N	N	N	N	N
3.3	335																N	N	N	N	N	N	N	N	N	N	N	N	N	N	N	N	N	N	N	N	N	N	N	N
4.7	475																N	N	N	N	N	N	N	N	N	N	N	N	N	N	N	N	N	N	N	N	N	N	N	N
6.8	685																N	N	N	N	N	N	N	N	N	N	N	N	N	N	N	N	N	N	N	N	N	N	N	N
10	106																N	N	N	N	N	N	N	N	N	N	N	N	N	N	N	N	N	N	N	N	N	N	N	N
22	226																N	N	N	N	N	N	N	N	N	N	N	N	N	N	N	N	N	N	N	N	N	N	N	N
33	336																N	N	N	N	N	N	N	N	N	N	N	N	N	N	N	N	N	N	N	N	N	N	N	N
47	476																N	N	N	N	N	N	N	N	N	N	N	N	N	N	N	N	N	N	N	N	N	N	N	N
100	107																N	N	N	N	N	N	N	N	N	N	N	N	N	N	N	N	N	N	N	N	N	N	N	N
150	157																N	N	N	N	N	N	N	N	N	N	N	N	N	N	N	N	N	N	N	N	N	N	N	N
220	227																N	N	N	N	N	N	N	N	N	N	N	N	N	N	N	N	N	N	N	N	N	N	N	N

* L 1.0±0.10 | W 0.5±0.10
 *1L 1.0±0.15 | W 0.5±0.15

MAX HEIGHT										
C	H	I	J	L	M	N	P	Q	R	U
0.33	0.55	0.65	0.7	0.90	0.95	1.00	1.35	1.40	1.45	1.80





DIELECTRIC		X7R																																							
DIMENSION (MM)		GMC32								GMC40				GMC43								GMC45								GMC55								GMC57			
L		3.2 ± 0.3								4.57 ± 0.25				4.5 ± 0.35								4.5 ± 0.35								5.7 ± 0.4								5.7 ± 0.4			
W		2.5 ± 0.3								2.03 ± 0.25				3.2 ± 0.3								6.3 ± 0.4								5.0 ± 0.4								6.3 ± 0.4			
BW		0.25 ~ 0.75								0.25 ~ 0.75				0.25 ~ 0.75								0.40 ~ 1.10								0.50 ~ 1.20								0.50 ~ 1.20			
RATED VOLTAGE		6.3	10	16	25	35	50	100	200	50	100	200	10	16	25	50	100	200	16	25	50	100	200	16	25	50	100	200	16	25	50	100	200	16	25	50	100	200			
CAP. RANGE																																									
1000pF	102	O	O	O	O	O	O	O	O	R	R	R	R	R	R	R	R	R	R	R	R	R	R	R	R	R	R	V	V	V	V	V	V	V	V	V	V				
1200	122	O	O	O	O	O	O	O	O	R	R	R	R	R	R	R	R	R	R	R	R	R	R	R	R	R	R	V	V	V	V	V	V	V	V	V	V				
1500	152	O	O	O	O	O	O	O	O	R	R	R	R	R	R	R	R	R	R	R	R	R	R	R	R	R	R	V	V	V	V	V	V	V	V	V	V				
1800	182	O	O	O	O	O	O	O	O	R	R	R	R	R	R	R	R	R	R	R	R	R	R	R	R	R	R	V	V	V	V	V	V	V	V	V	V				
2200	222	O	O	O	O	O	O	O	O	R	R	R	R	R	R	R	R	R	R	R	R	R	R	R	R	R	R	V	V	V	V	V	V	V	V	V	V				
2400	242	O	O	O	O	O	O	O	O	R	R	R	R	R	R	R	R	R	R	R	R	R	R	R	R	R	R	V	V	V	V	V	V	V	V	V	V				
2700	272	O	O	O	O	O	O	O	O	R	R	R	R	R	R	R	R	R	R	R	R	R	R	R	R	R	R	V	V	V	V	V	V	V	V	V	V				
3000	302	O	O	O	O	O	O	O	O	R	R	R	R	R	R	R	R	R	R	R	R	R	R	R	R	R	R	V	V	V	V	V	V	V	V	V	V				
3300	332	O	O	O	O	O	O	O	O	R	R	R	R	R	R	R	R	R	R	R	R	R	R	R	R	R	R	V	V	V	V	V	V	V	V	V	V				
3600	362	O	O	O	O	O	O	O	O	R	R	R	R	R	R	R	R	R	R	R	R	R	R	R	R	R	R	V	V	V	V	V	V	V	V	V	V				
3900	392	O	O	O	O	O	O	O	O	R	R	R	R	R	R	R	R	R	R	R	R	R	R	R	R	R	R	V	V	V	V	V	V	V	V	V	V				
4300	432	O	O	O	O	O	O	O	O	R	R	R	R	R	R	R	R	R	R	R	R	R	R	R	R	R	R	V	V	V	V	V	V	V	V	V	V				

MAX HEIGHT		
O	R	V
1.10	1.45	2.20



DIELECTRIC		X6S																																		
DIMENSION (MM)		GMC02				GMC04				GMC10				GMC21				GMC31																		
L		0.6 ± 0.03				1.0 ± 0.05				1.6 ± 0.2				2.0 ± 0.3				3.2 ± 0.3																		
W		0.3 ± 0.03				0.5 ± 0.05				0.8 ± 0.2				1.25 ± 0.2				1.6 ± 0.2																		
BW		0.15 ± 0.05				0.1 ~ 0.35				0.1 ~ 0.4				0.25 ~ 0.75				0.25 ~ 0.75																		
RATED VOLTAGE		4	6.3	10	16	25	35	4	6.3	10	16	25	35	50	4	6.3	10	16	25	35	50	4	6.3	10	16	25	35	50	4	6.3	10	16	25	35	50	100
CAP. RANGE																																				
2200pF	222	C	C	C	C	C																														
4700	472	C	C	C	C	C																														
.01uf	103	C	C	C	C	C	H	H	H	H	H	H	H																							
0.012	123	C	C				H	H	H	H	H	H	H																							
0.015	153	C	C				H	H	H	H	H	H	H																							
0.018	183	C	C				H	H	H	H	H	H	H																							
0.022	223	C	C	C	C	C	H	H	H	H	H	H	H																							
0.027	273	C	C	C	C		H	H	H	H	H																									
0.033	333	C	C	C	C		H	H	H	H	H	H	H																							
0.039	393	C	C																																	
0.047	473	C	C	C	C	C	H	H	H	H	H	H	H																							
0.056	563	C	C				H	H	H	H	H	H	J	J																						
0.068	683	C	C	C	C		H	H	H	H	H	H	J	J																						
0.082	823	C	C				H	H	H	H	H	H	J	J																						
0.1	104	C	C	C	C		H	H	H	H	H	H	J	J																						
0.12	124						H	H																												
0.15	154						H	H	H	H	H				M	M	M	M	M	M	M															
0.18	184						H	H							M	M	M	M	M																	
0.22	224	C	C				H	H	H	H	H	H			M	M	M	M	M	M	M															
0.27	274						H	H							M	M	M	M																		
0.33	334						H	H	H	H					M	M	M	M	M	M																
0.39	394						H	H							M	M	M	M																		
0.47	474	E	E	E	E		H	H	H	H					M	M	M	M	M	M	M	R	R	R	R	R	R	R	R	R	R	R	R	R		
0.56	564						H	H							M	M	M	M				R	R	R	R											
0.68	684						H	H	H	H					M	M	M	M	M	M	M	R	R	R	R	R	R	R	R	R	R	R	R	R	R	
0.82	824						H	H							M	M	M	M				R	R	R	R											
1	105	E	E	E	E		J	J	J	J	J	J			M	M	M	M	M	M	M	R	R	R	R	R	R	R	R	T	T	T	T	T	T	
1.5	155														N	N	N	N				R	R	R	R	R	R	R	R	U	U	U	U	U	U	
2.2	225						J	J	J	J	J				N	N	N	N				R	R	R	R	R	R	R	U	U	U	U	U	U	U	
2.7	275																																			
3.3	335														N	N	N	N				R	R	R	R	R	R	R	U	U	U	U	U	U	U	
3.9	395																																			
4.7	475						I	I							N	N	N	N	N			R	R	R	R	R	R	R	U	U	U	U	U	U	U	
6.8	685														N	N	N					R	R	R	R				U	U	U	U	U	U	U	
10	106						J	J							N	N	N	N				R	R	R	R	R			U	U	U	U	U	U	U	
15	156																					R	R	R	R			U	U	U	U					
22	226						K								N	N						R	R	R	R			U	U	U	U	U				
33	336																					R					U	U	U							
47	476														N							R	R				U	U	U							
68	686																										U									
100	107																								R		U	U								
150	157																										U									
220	227																										U									

MAX HEIGHT										
C	E	H	I	J	K	M	N	R	T	U
0.33	0.39	0.55	0.65	0.7	0.8	0.95	1.00	1.45	1.80	1.90





		X6S													
DIMENSION (MM)		GMC32							GMC43						
L		3.2 ± 0.30							4.5 ± 0.35						
W		2.5 ± 0.30							3.2 ± 0.30						
BW		0.75 ± 0.25							0.25 ~ 0.75						
RATED VOLTAGE		4	6.3	10	16	25	35	50	4	6.3	10	16	25	35	50
CAP. RANGE															
3.3uF	335					Z	Z	Z							
4.7	475					Z	Z	Z							
6.8	685					Z	Z	Z							
10	106			Z	Z	Z	Z	Z							
22	226			Y	Y	Y									
33	336														
47	476		Y	Y	Y										
68	686														
100	107	Z	Z	Z					A1	A1					
150	157	Z													
220	227	Z	Z												
330	337	Z	Z												

MAX HEIGHT		
Y	Z	A1
2.8	2.9	3.1

PACKAGING (TAPING)

Per EIA-481 - Reel Type Size

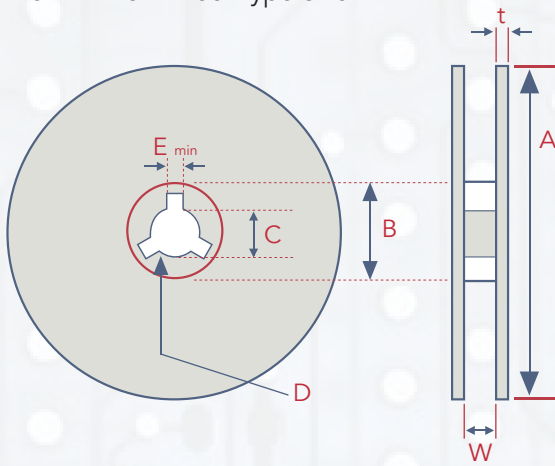

UNIT: mm

SYMBOL	TAPE WIDTH	A	B	C	D	E	W	t
7" Reel	8mm	Ø178±2.0	MINØ50	Ø13±0.5	21±0.8	2.0±0.5	10±0.5	0.9±0.2
	12mm	Ø178±2.0	MINØ50	Ø13±0.5	21±0.8	2.0±0.5	13±0.5	1.2±0.2
10" Reel	8mm	Ø258±2.0	MINØ70	Ø13±0.5	21±0.8	2.0±0.5	10±0.5	1.8±0.2
	12mm	Ø258±2.0	MINØ70	Ø13±0.5	21±0.8	2.0±0.5	13±0.5	2.2±0.2

CarrierTape (Standard)

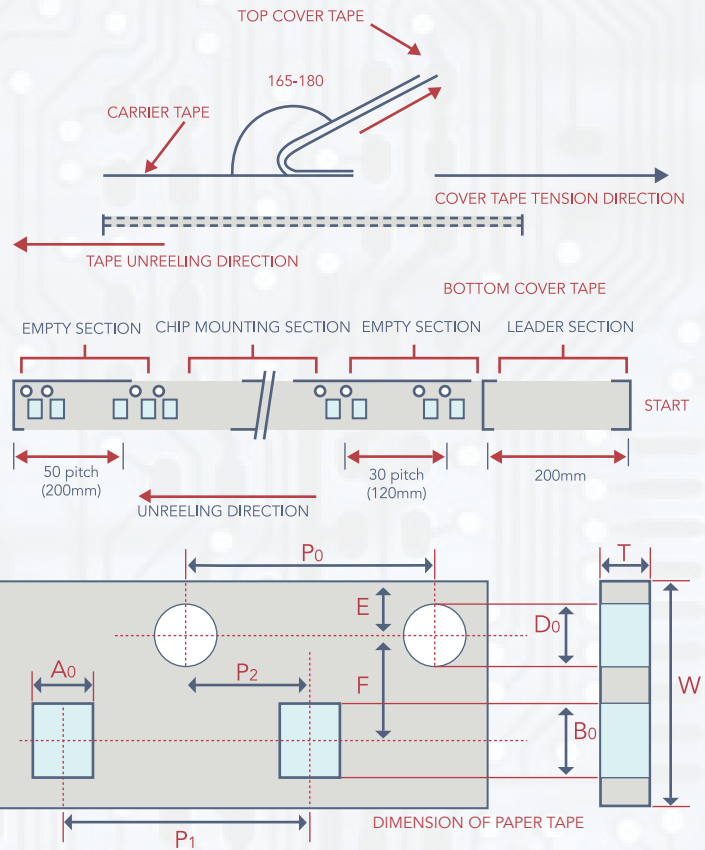

- To peel off the cover tape by the method shown in the right figure apply a peel-off force of 20GF - 60GF (card board); 10GF - 75GF (plastic tape).

-The cover tape should not touch the top or bottom of the chip.

- If the cover tape has been peeled off it may be difficult to remove the chip due to punch-hole clearance, dirt, and debris. Make sure therefore that no paper waste will adhere to and block the absorption nozzle.

- If the cover tape has been peeled off from the top, stick it back on with a suitable adhesive.

- Follow the illustration for the start and end of the winding operation.

CARDBOARD CARRIER TAPE FOR 01005, 0201, 0402, 0603, 0805, 1206

UNIT=mm

TYPE	A ₀	B ₀	T	K ₀	W	P ₀	10XP ₀	P ₁	P ₂	D ₀	D ₁	E	F	MOUNTING HOLE	STD. REEL QTY 7"	OPTIONAL REEL QTY (10/13")
01005	0.25±0.04	0.45±0.04	0.36±0.05	*	8.0±0.30	4.0±0.10	40.0±0.10	2.0±0.05	2.0±0.05	1.5±0.1	*	1.75±0.1	3.5±0.05	Angular Punch Hole	20,000	50,000 D
0201	0.39±0.07	0.69±0.07	<0.50	*	8.0±0.10	4.0±0.10	40.0±0.10	2.0±0.05	2.0±0.05	1.55±0.05	*	1.75±0.05	3.5±0.05		10,000 15,000	50,000 D
0402	0.7±0.20	1.2±0.20	<0.80	*	8.0±0.10	4.0±0.10	40.0±0.10	2.0±0.05	2.0±0.05	1.55±0.05	*	1.75±0.05	3.5±0.05		10,000	40,000 D 50,000 G
0603	1.1±0.20	1.9±0.20	<1.20	*	8.0±0.10	4.0±0.10	40.0±0.10	2.0±0.05	2.0±0.05	1.55±0.05	*	1.75±0.05	3.5±0.05		4,000	10,000 D 15,000 G
0805	1.65±0.20	2.4±0.20	<01.30	*	8.0±0.10	4.0±0.10	40.0±0.10	2.0±0.05	2.0±0.05	1.55±0.05	*	1.75±0.05	3.5±0.05		4,000	10,000 D 15,000 G 20,000 Q
1206	2.0±0.20	3.6±0.20	<01.30	*	8.0±0.10	4.0±0.10	40.0±0.10	2.0±0.05	2.0±0.05	1.55±0.05	*	1.75±0.05	3.5±0.05		4,000	10,000 D 15,000 G 20,000 Q

PACKAGING (TAPING)

Tape & Reel Dimensions

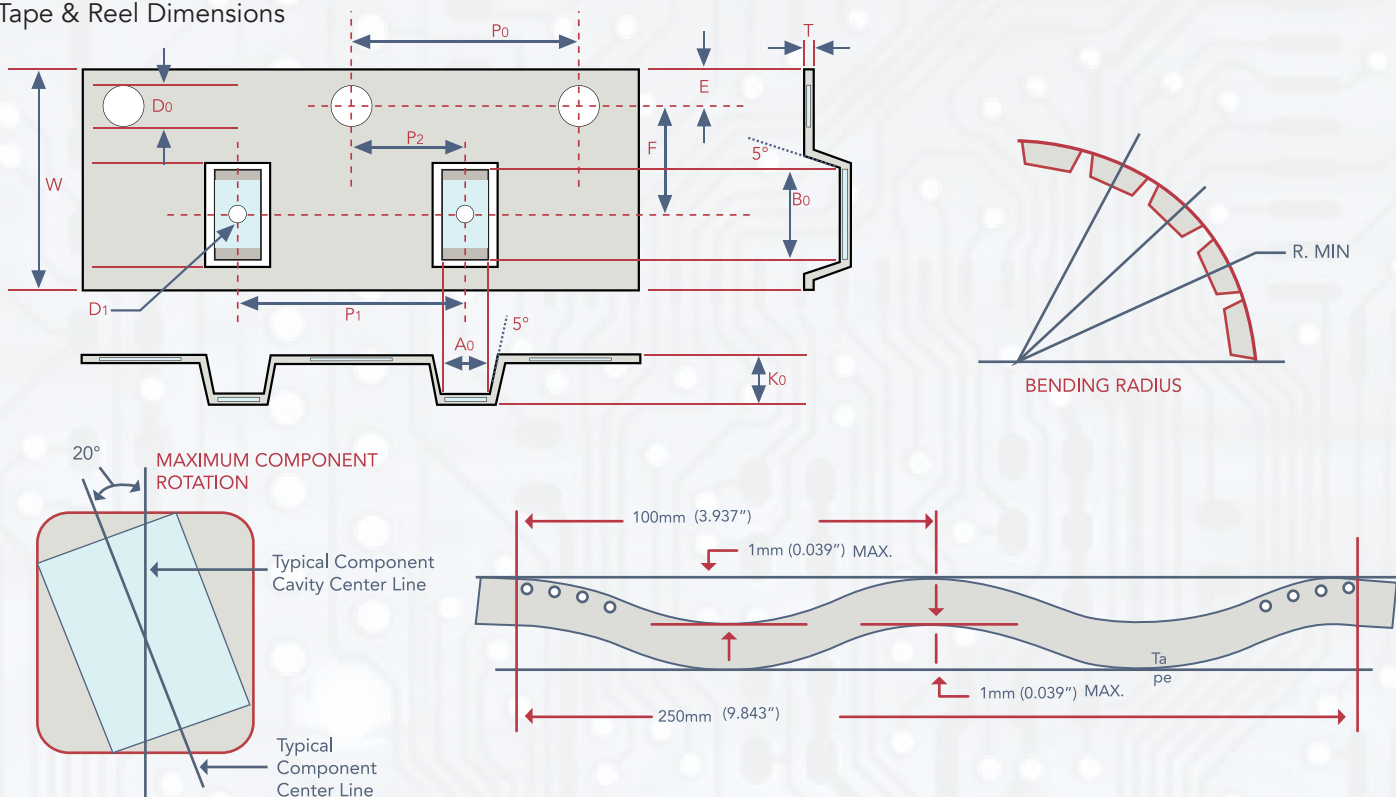

• Embossed plastic carrier tape for 0805/1206/1210/1808/1812/1825/2220 AND 2225 type

TYPE	A ₀	B ₀	T	K ₀	W	P ₀	10XP ₀	P ₁	P ₂	D ₀	D ₁	E	F	MOUNTING HOLE	STD. REEL QTY 7"	OPTIONAL REEL QTY (10/13")
0805	<1.80	<2.70	0.23±0.10	<2.50	8.0±0.20	4.0±0.10	40.0±0.20	4.0±0.10	2.0±0.05	1.5±0.10	1.0±0.10	1.75±0.10	3.5±0.05	Angular Embossed Hole	2,000 3,000	10,000 D 15,000 G
1206	<2.30	<4.00	0.23±0.10	<2.50	8.0±0.20	4.0±0.10	40.0±0.20	4.0±0.10	2.0±0.05	1.5±0.10	1.0±0.10	1.75±0.10	3.5±0.05		2,000 3,000	8,000 D 10,000 G
1210	<3.20	<3.95	0.23±0.10	<3.00	8.0±0.20	4.0±0.10	40.0±0.20	4.0±0.10	2.0±0.05	1.5±0.10	1.0±0.10	1.75±0.10	3.5±0.05		500 1,000 2,000 3,000	4,000 D 8,000 G
1808	<2.50	<5.30	0.25±0.10	<2.50	12.0±0.20	4.0±0.10	40.0±0.20	4.0±0.10	2.0±0.05	1.5±0.10	1.0±0.10	1.75±0.10	5.5±0.10		1,000 2,000 3,000	
1812	<3.90	<5.30	0.25±0.10	<3.50	12.0±0.20	4.0±0.10	40.0±0.20	8.0±0.10	2.0±0.05	1.5±0.10	1.5±0.10	1.75±0.10	5.5±0.10		500 1,000	3,000 D
1825	<6.80	<5.30	0.30±0.10	<3.10	12.0±0.20	4.0±0.10	40.0±0.20	8.0±0.10	2.0±0.05	1.5±0.10	1.5±0.10	1.75±0.10	5.5±0.10		500 1,000	
2220	<5.80	<6.50	0.30±0.10	<3.10	12.0±0.20	4.0±0.10	40.0±0.20	8.0±0.10	2.0±0.05	1.5±0.10	1.5±0.10	1.75±0.10	5.5±0.10		500 700 1,000	
2225	<6.80	<6.50	0.30±0.10	<3.10	12.0±0.20	4.0±0.10	40.0±0.20	8.0±0.10	2.0±0.05	1.5±0.10	1.5±0.10	1.75±0.10	5.5±0.10		500 700	

WARRANTY: All passive components supplied by Calchip Electronics, 59 Steamwhistle Drive, Ivyland, PA, 18974, are under warranty for a period of 2 years from the date of manufacture. Product will meet or exceed all reliability and test specifications expressed by Calchip for the above mentioned time period provided storage conditions (stated below) are met. Product Storage Instructions:

- 1) Product must be kept away from direct sunlight.
- 2) Product must be stored in the following conditions - Temperature; 5 to 35 degrees Celsius / 40 to 95 degrees Fahrenheit Humidity; 45 to 85%
- 3) Product to be kept free of moisture, dirt and debris.

WHEN THESE CONDITIONS ARE NOT MET, PRODUCT LIFE COULD BE SHORTENED

NOTICE: Specifications are subject to change without notice. Contact your nearest Cal-Chip Sales Office for the latest specifications. All statements, information and data given herein are believed to be accurate and reliable, but are presented without guarantee, warranty, or responsibility of any kind, expressed or implied. Statements or suggestions concerning possible use of our products are made without representation or warranty that any such use is free of patent infringement and are not recommendations to infringe any patent. The user should not assume that all safety measures are indicated or that other measures may not be required. Specifications are typical and may not apply to all applications.

BARCODE LABEL



CCE P/N GMC21X5R475K50NT



Cust PN



QTY 2000 ea



Date Code 2132 32nd week of 2021



Lot Code 2065112



Looking for pricing, stock, or lifecycle information?

Click below to explore more details on WIN SOURCE:

- ⊖ [View GMC04X5R106M10NT on WIN SOURCE](#)
- ⊖ [CAL-CHIP ELECTRONICS, INC. Information](#)

Optimize Your Supply Chain with WIN SOURCE Solutions

- ✓ Global Sourcing Solution
- ✓ Obsolete Management
- ✓ Cost Control Management
- ✓ Shortage Management
- ✓ Alternative Solution
- ✓ Excess Inventory Management