



**THE DATASHEET OF
N01S830BAT22IT**



ON Semiconductor

Is Now

onsemi™

To learn more about onsemi™, please visit our website at
www.onsemi.com

onsemi and **onsemi** and other names, marks, and brands are registered and/or common law trademarks of Semiconductor Components Industries, LLC dba "**onsemi**" or its affiliates and/or subsidiaries in the United States and/or other countries. **onsemi** owns the rights to a number of patents, trademarks, copyrights, trade secrets, and other intellectual property. A listing of **onsemi** product/patent coverage may be accessed at www.onsemi.com/site/pdf/Patent-Marking.pdf. **onsemi** reserves the right to make changes at any time to any products or information herein, without notice. The information herein is provided "as-is" and **onsemi** makes no warranty, representation or guarantee regarding the accuracy of the information, product features, availability, functionality, or suitability of its products for any particular purpose, nor does **onsemi** assume any liability arising out of the application or use of any product or circuit, and specifically disclaims any and all liability, including without limitation special, consequential or incidental damages. Buyer is responsible for its products and applications using **onsemi** products, including compliance with all laws, regulations and safety requirements or standards, regardless of any support or applications information provided by **onsemi**. "Typical" parameters which may be provided in **onsemi** data sheets and/or specifications can and do vary in different applications and actual performance may vary over time. All operating parameters, including "Typicals" must be validated for each customer application by customer's technical experts. **onsemi** does not convey any license under any of its intellectual property rights nor the rights of others. **onsemi** products are not designed, intended, or authorized for use as a critical component in life support systems or any FDA Class 3 medical devices or medical devices with a same or similar classification in a foreign jurisdiction or any devices intended for implantation in the human body. Should Buyer purchase or use **onsemi** products for any such unintended or unauthorized application, Buyer shall indemnify and hold **onsemi** and its officers, employees, subsidiaries, affiliates, and distributors harmless against all claims, costs, damages, and expenses, and reasonable attorney fees arising out of, directly or indirectly, any claim of personal injury or death associated with such unintended or unauthorized use, even if such claim alleges that **onsemi** was negligent regarding the design or manufacture of the part. **onsemi** is an Equal Opportunity/Affirmative Action Employer. This literature is subject to all applicable copyright laws and is not for resale in any manner. Other names and brands may be claimed as the property of others.

N01S830HA, N01S830BA

1 Mb Ultra-Low Power Serial SRAM

Standard SPI Interface and Multiplex DUAL and QUAD Interface

Overview

The ON Semiconductor serial SRAM family includes several integrated memory devices including this 1 Mb serially accessed Static Random Access Memory, internally organized as 128 K words by 8 bits. The devices are designed and fabricated using ON Semiconductor's advanced CMOS technology to provide both high-speed performance and low power. The devices operate with a single chip select (\overline{CS}) input and use a simple Serial Peripheral Interface (SPI) protocol. In SPI mode, a single data-in (SI) and data-out (SO) line is used along with the clock (SCK) to access data within the device. In DUAL mode, two multiplexed data-in/data-out (SIO0-SIO1) lines are used and in QUAD mode, four multiplexed data-in/data-out (SIO0-SIO3) lines are used with the clock to access the memory. The devices can operate over a wide temperature range of -40°C to $+85^{\circ}\text{C}$ ($+125^{\circ}\text{C}$ for E-Temp) and are available in a 8-lead TSSOP package. The N01S830xA device has two different variations, a HOLD version that allows communication to the device to be paused and a battery back-up (BBU) version to be used with a battery to retain data when power is lost.

Features

- Power Supply Range: 2.5 to 5.5 V
- Very Low Typical Standby Current $< 4 \mu\text{A}$ at $+85^{\circ}\text{C}$
- Very Low Operating Current $< 10 \text{ mA}$
- Simple Serial Interface
 - ◆ Single-bit SPI Access
 - ◆ DUAL-bit and QUAD-bit SPI-like Access
- Flexible Operating Modes
 - ◆ Word Mode
 - ◆ Page Mode
 - ◆ Burst Mode (Full Array)
- High Frequency Read and Write Operation
 - ◆ Clock Frequency up to 20 MHz
- Functional Options
 - ◆ HOLD Pin for Pausing Operation
 - ◆ VBAT Pin for Battery-Back up
- Built-in Write Protection (\overline{CS} High)
- High Reliability
 - ◆ Unlimited Write Cycles
- Temperature Ranges Supported
 - ◆ Industrial (I): $T_A = -40^{\circ}\text{C}$ to $+85^{\circ}\text{C}$
 - ◆ Automotive (E): $T_A = -40^{\circ}\text{C}$ to $+125^{\circ}\text{C}$
- These Devices are Pb-Free and are RoHS Compliant
 - ◆ Green TSSOP



ON Semiconductor®

www.onsemi.com

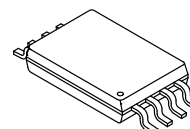

TSSOP8 3x4.4
CASE 948BH

PACKAGE CONFIGURATION

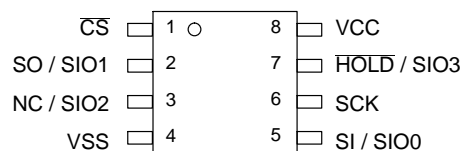

HOLD Version

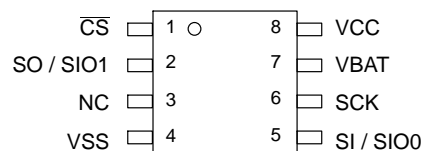

BBU Version

ORDERING INFORMATION

Device	Package	Shipping†
N01S830HAT22I	TSSOP-8 (Pb-Free)	100 Units / Tube
N01S830BAT22I		
N01S830HAT22IT	TSSOP-8 (Pb-Free)	3000 / Tape & Reel
N01S830BAT22IT		
N01S830HAT22E	TSSOP-8 (Pb-Free)	100 Units / Tube
N01S830BAT22E		
N01S830HAT22ET	TSSOP-8 (Pb-Free)	3000 / Tape & Reel
N01S830BAT22ET		

†For information on tape and reel specifications, including part orientation and tape sizes, please refer to our Tape and Reel Packaging Specification Brochure, BRD8011/D.

N01S830HA, N01S830BA

Table 1. DEVICE OPTIONS

Device / Part Number	Power Supply	Speed	Package	Temperature Range	Function
N01S830HAT22	HV 2.5 V – 5.5 V	20 MHz for I–Temp, 16 MHz E–Temp	TSSOP–8	I, E	HOLD
N01S830BAT22	HV 2.5 V – 5.5 V	20 MHz for I–Temp, 16 MHz E–Temp	TSSOP–8	I, E	BBU – Battery Back-up

Table 2. PIN NAMES

Pin Name	Pin Function
\overline{CS}	Chip Select
SCK	Serial Clock
SI / SIO0	Data Input – SPI mode Data Input/Output 0 – DUAL and QUAD mode
SO / SIO1	Data Output – SPI mode Data Input/Output 1 – DUAL and QUAD mode
NC / SIO2	No Connect – SPI and DUAL mode Data Input/Output 2 – QUAD mode
HOLD / SIO3	HOLD Version HOLD Input – SPI and DUAL mode Data Input/Output 3 – QUAD mode
VBAT	BBU Version Battery Supply – SPI and DUAL mode
V _{CC}	Power
V _{SS}	Ground

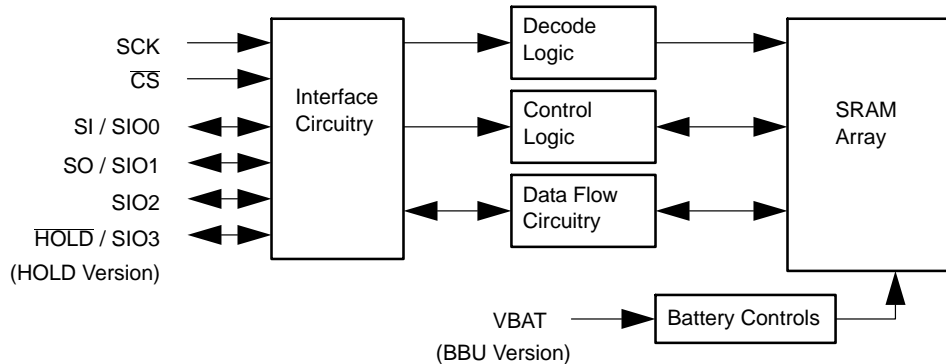

Figure 1. Functional Block Diagram

Table 3. CONTROL SIGNAL DESCRIPTIONS

Signal	Mode Used	Name	Description
\overline{CS}	All	Chip Select	A low level selects the device and a high level puts the device in standby mode. If \overline{CS} is brought high during a program cycle, the cycle will complete and then the device will enter standby mode. When \overline{CS} is high, SO is in high-Z. \overline{CS} must be driven low after power-up prior to any sequence being started.
SCK	All	Serial Clock	Synchronizes all activities between the memory and controller. All incoming addresses, data and instructions are latched on the rising edge of SCK. Data out is updated after the falling edge of SCK.
SI	SPI	Serial Data In	Receives instructions, addresses and data on the rising edge of SCK.
SO	SPI	Serial Data Out	Data is transferred out after the falling edge of SCK.

Table 3. CONTROL SIGNAL DESCRIPTIONS

Signal	Mode Used	Name	Description
$\overline{\text{HOLD}}$	SPI and DUAL	Hold	A high level is required for normal operation. Once the device is selected and a serial sequence is started, this input may be taken low to pause serial communication without resetting the serial sequence. The pin must be brought low while SCK is low for immediate use. If SCK is not low, the HOLD function will not be invoked until the next SCK high to low transition. The device must remain selected during this sequence. SO is high-Z during the Hold time and SI and SCK are inputs are ignored. To resume operations, HOLD must be pulled high while the SCK pin is low. Lowering the HOLD input at any time will take to SO output to High-Z.
VBAT	SPI and DUAL	Battery Voltage	Provides the battery power connection to retain data in battery backed mode.
SIO0 - 1	DUAL	Serial Data Input / Output	Receives instructions, addresses and data on the rising edge of SCK. Data is transferred out after the falling edge of SCK. The instruction must be set after power-up to enable the DUAL access mode.
SIO0 - 3	QUAD	Serial Data Input / Output	Receives instructions, addresses and data on the rising edge of SCK. Data is transferred out after the falling edge of SCK. The instruction must be set after power-up to enable the QUAD access mode.

Basic Operation

The 1 Mb serial SRAM is designed to interface directly with a standard Serial Peripheral Interface (SPI) common on many standard micro-controllers in the default state. It may also interface with other non-SPI ports by programming discrete I/O lines to operate the device.

The serial SRAM contains an 8-bit instruction register and is accessed via the SI pin. The $\overline{\text{CS}}$ pin must be low and the HOLD pin must be high for the entire operation. Data is sampled on the first rising edge of SCK after $\overline{\text{CS}}$ goes low. If the clock line is shared, the user can assert the $\overline{\text{HOLD}}$ input and place the device into a Hold mode. After releasing the HOLD pin, the operation will resume from the point where it was held. The Hold operation is only supported in SPI and DUAL modes.

By programming the device through a command instruction, the dual and quad access modes may be initiated. In these modes, multiplexed I/O lines take the place of the SPI SI and SO pins and along with the $\overline{\text{CS}}$ and SCK control the device in a SPI-like, two bit (DUAL) and four bit (QUAD) wide serial manner. Once the device is put into either the DUAL or QUAD mode, the device will remain operating in that mode until powered down or the Reset Mode operation is programmed.

The following table contains the possible instructions and formats. All instructions, addresses and data are transferred MSB first and LSB last.

Table 4. INSTRUCTION SET

Instruction	Command	Description
READ	03h	Read data from memory starting at selected address
WRITE	02h	Write (program) data to memory starting at selected address
EQIO	38h	Enable QUAD I/O access
EDIO	3Bh	Enable DUAL I/O access
RSTQIO	FFh	Reset from QUAD and DUAL to SPI I/O access
RDMR	05h	Read mode register
WRMR	01h	Write mode register

N01S830HA, N01S830BA

DEVICE OPERATIONS

Read Operation

The serial SRAM Read operation is started by enabling \overline{CS} low. First, the 8-bit Read instruction is transmitted to the device through the SI (or SIO0-3) pin(s) followed by the 24-bit address with the 7 MSBs of the address being “don’t care” bits and ignored. In SPI mode, after the READ instruction and address bits are sent, the data stored at that address in memory is shifted out on the SO pin after the output valid time. Additional “dummy” clock cycles (four in DUAL and two in QUAD) are required to follow the instruction and address inputs prior to the data being driven out on the SIO0-3 pins while operating in these two modes.

By continuing to provide clock cycles to the device, data can continue to be read out of the memory array in sequentially. The internal address pointer is automatically incremented to the next higher address after each byte of data is read out until the highest memory address is reached. When the highest memory address is reached, 1FFFFh, the address pointer wraps to the address 00000h. This allows the read cycles to be continued indefinitely. All Read operations are terminated by pulling \overline{CS} high.

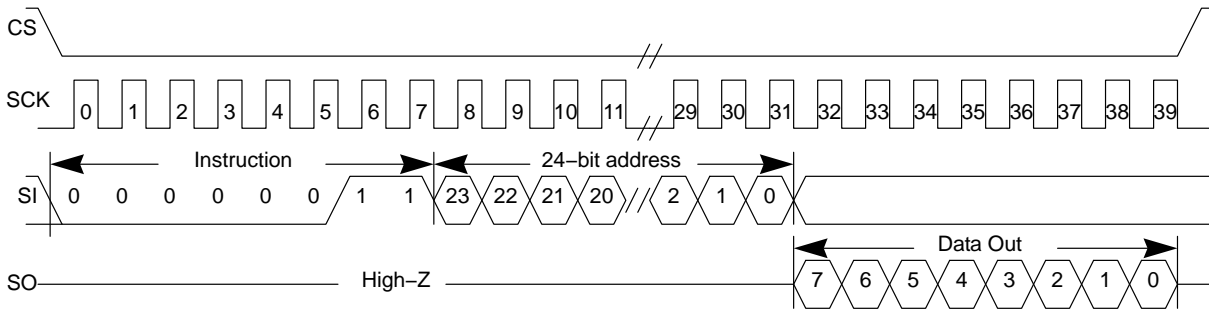

Figure 2. SPI Read Sequence (Single Byte)

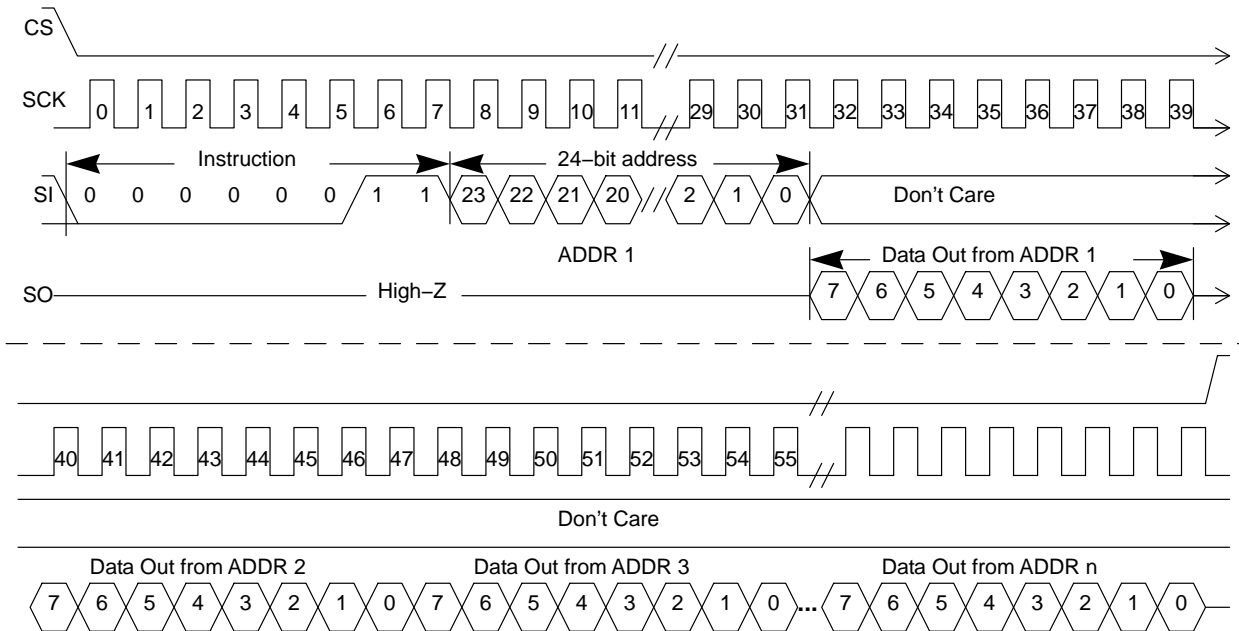
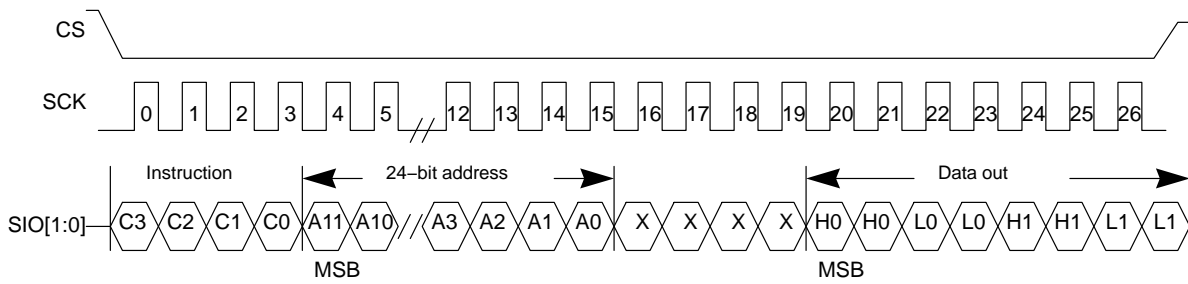

Figure 3. SPI Read Sequence (Sequential Bytes)

N01S830HA, N01S830BA



- Notes:** C[3:0] = 03h
H0 = 2 high order bits of data byte 0
L0 = 2 low order bits of data byte 0
H1 = 2 high order bits of data byte 1
L1 = 2 low order bits of data byte 1

Figure 4. DUAL Read Sequence

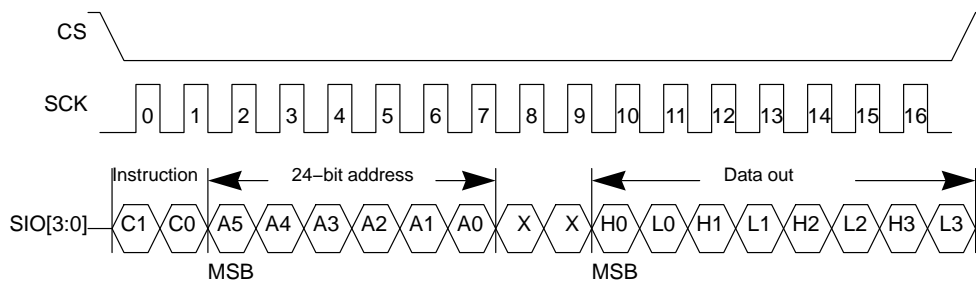

- Notes:** C[1:0] = 03h
H0 = 4 high order bits of data byte 0
L0 = 4 low order bits of data byte 0
H1 = 4 high order bits of data byte 1
L1 = 4 low order bits of data byte 1

Figure 5. QUAD Read Sequence

Write Operation

The serial SRAM WRITE is selected by enabling \overline{CS} low. First, the 8-bit WRITE instruction is transmitted to the device followed by the 24-bit address with the 7 MSBs being don't care. After the WRITE instruction and addresses are sent, the data to be stored in memory is shifted in on the SI pin.

If operating in page mode, after the initial word of data is shifted in, additional data words can be written as long as the address requested is sequential on the same page. Simply write the data on SI pin and continue to provide clock pulses. The internal address pointer is automatically incremented to the next higher address on the page after each word of data is written in. This can be continued for the entire page length of 32 words long. At the end of the page, the addresses pointer will be wrapped to the 0 word address within the

page and the operation can be continuously looped over the 32 words of the same page. The new data will replace data already stored in the memory locations.

If operating in burst mode, after the initial word of data is shifted in, additional data words can be written to the next sequential memory locations by continuing to provide clock pulses. The internal address pointer is automatically incremented to the next higher address after each word of data is read out. This can be continued for the entire array and when the highest address is reached, 1FFFFh, the address counter wraps to the address 00000h. This allows the burst write cycle to be continued indefinitely. Again, the new data will replace data already stored in the memory locations.

All WRITE operations are terminated by pulling \overline{CS} high.

N01S830HA, N01S830BA

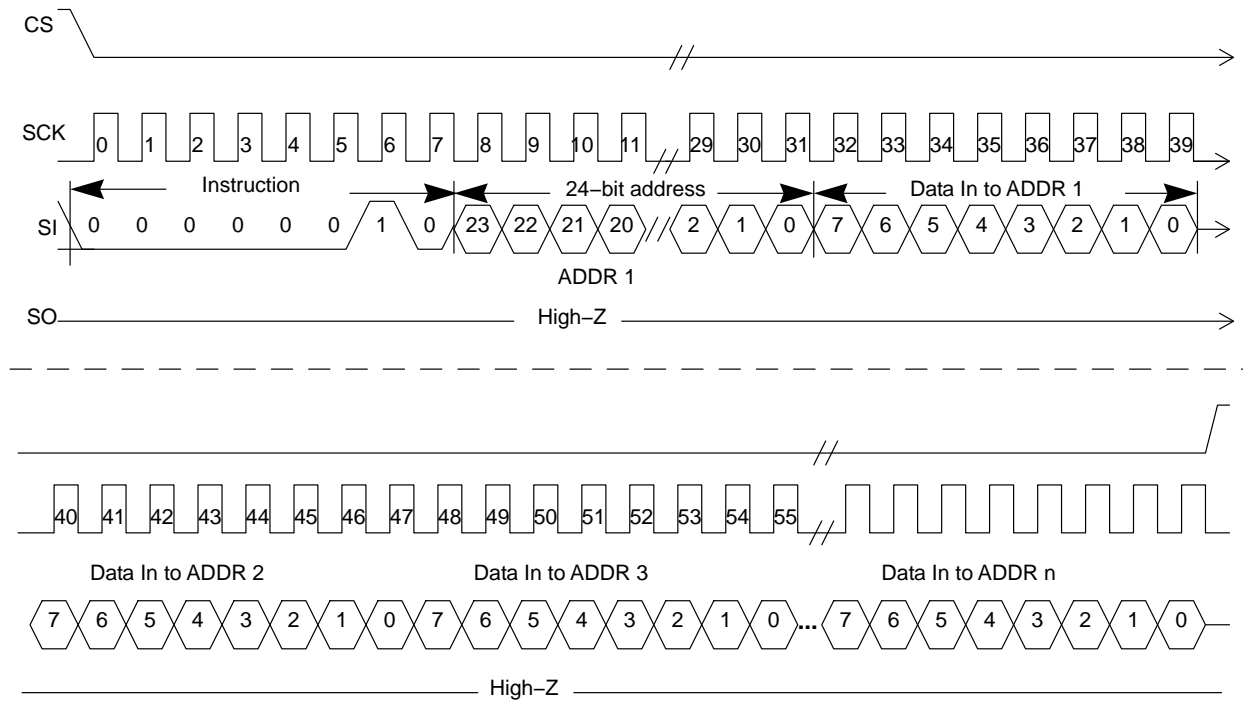
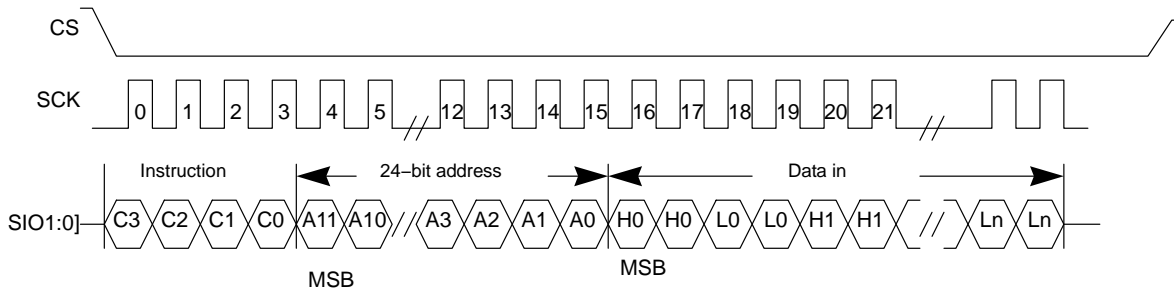

Figure 6. SPI Write Sequence



- Notes:**
- C[3:0] = 02h
 - H0 = 2 high order bits of data byte 0
 - L0 = 2 low order bits of data byte 0
 - H1 = 2 high order bits of data byte 1
 - L1 = 2 low order bits of data byte 1

Figure 7. DUAL Write Sequence

N01S830HA, N01S830BA

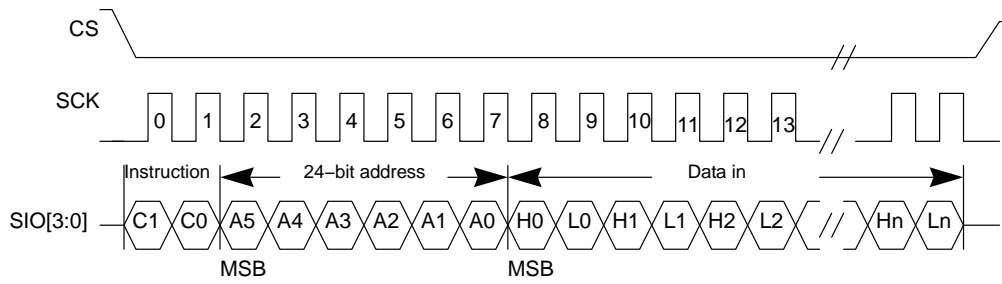

- Notes:** C[1:0] = 02h
 H0 = 4 high order bits of data byte 0
 L0 = 4 low order bits of data byte 0
 H1 = 4 high order bits of data byte 1
 L1 = 4 low order bits of data byte 1

Figure 8. QUAD Write Sequence

READ Mode Register (RDMR)

This instruction provides the ability to read the mode register. The register may be read at any time including during a Write operation. The Read Mode Register operation is executed by driving \overline{CS} low, then sending the

RDMR instruction to the device. Immediately after the instruction, the device outputs data on the SO (SIO0-3) pin(s). To complete the operation, drive \overline{CS} high to terminate the register read.

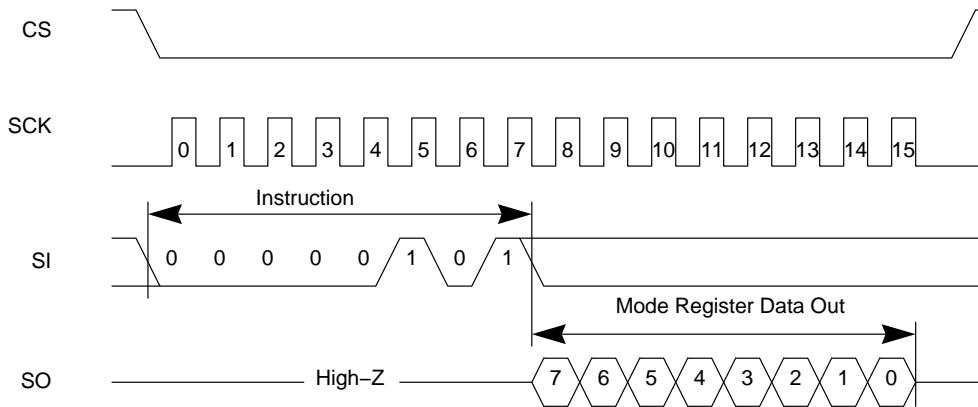
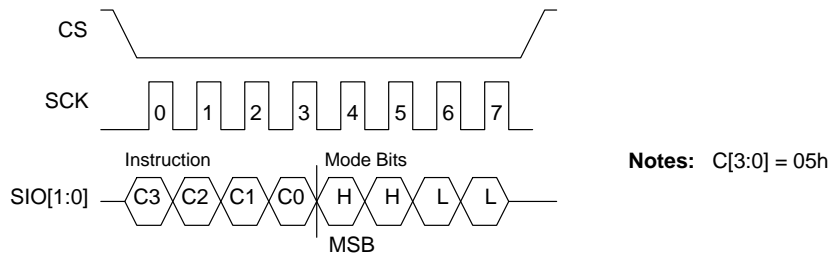

Figure 9. SPI Read Mode Register Sequence (RDMR)



- Notes:** C[3:0] = 05h

Figure 10. DUAL Read Mode Register Sequence (RDMR)

N01S830HA, N01S830BA

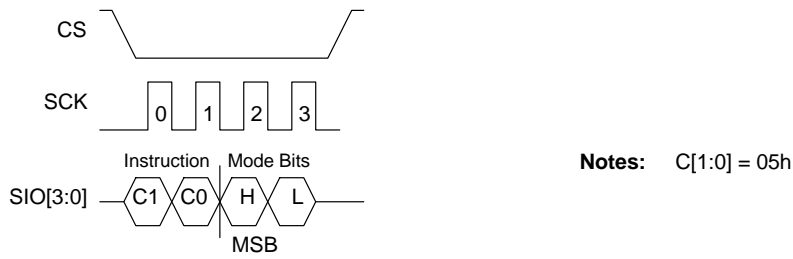

Figure 11. QUAD Read Mode Register Sequence (RDMR)

Write Mode Register (WRMR)

This instruction provides the ability to write the mode register. The Write Mode Register operation is executed by driving \overline{CS} low, then sending the WRMR instruction to the

device. Immediately after the instruction, the data is driven to the device on the SO (SIO0-3) pin(s). To complete the operation, drive \overline{CS} high to terminate the register write.

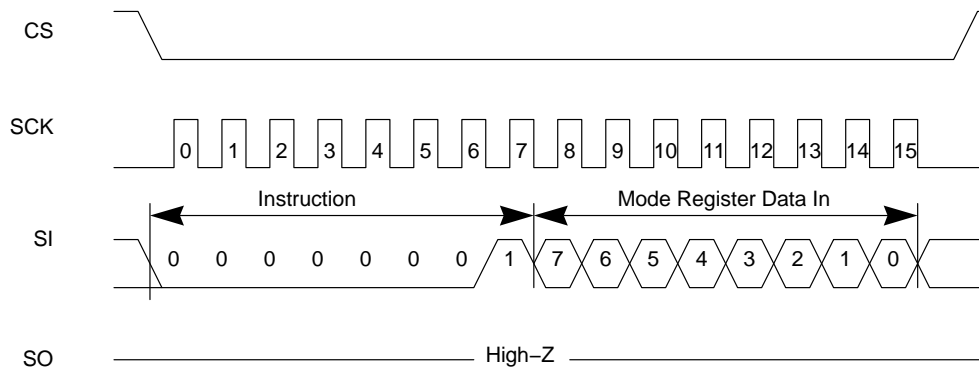

Figure 12. SPI Write Mode Register Sequence

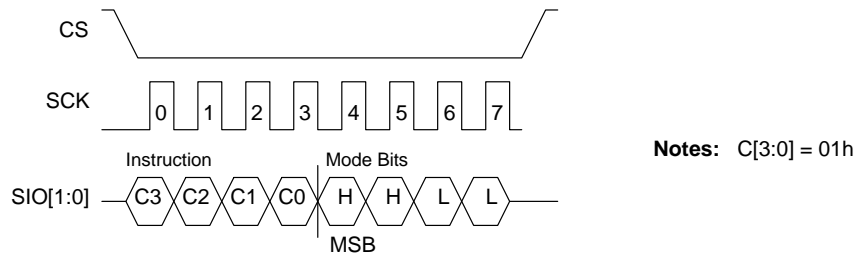

Figure 13. DUAL Write Mode Register Sequence

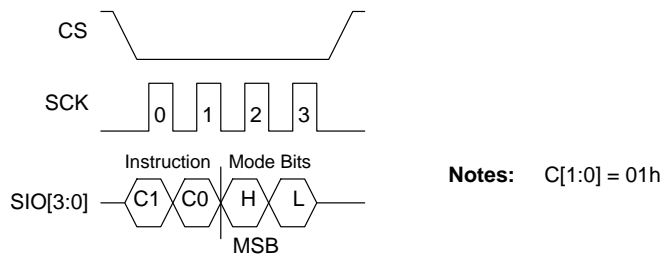

Figure 14. QUAD Write Mode Register Sequence

N01S830HA, N01S830BA

Table 5. MODE REGISTER

Bit	Function
0	Hold Function 1 = Hold function disabled 0 = Hold function enabled (Default)
1	Reserved
2	Reserved
3	Reserved
4	Reserved
5	Reserved
6	Operating Mode Bit 7 Bit 6
	0 0 = Word Mode
	1 0 = Page Mode
7	0 1 = Burst Mode (Default)
	1 1 = Reserved

Power-Up State

The serial SRAM enters a know state at power-up time. The device is in low-power standby state with $\overline{CS} = 1$. A low level on \overline{CS} is required to enter a active state.

Battery Back-Up Operation

The Battery Back-Up function is available on the BBU version of the serial SRAM. This version of the SRAM cannot operate in the QUAD mode since the SIO3 input is used for the VBAT connection. A standard coin cell battery should be connected to the VBAT pin. On chip circuitry monitors the V_{CC} pin and when it is determined that the main V_{CC} power supply is turning off, the device automatically switches the memory array to VBAT power input. When in battery back-up mode and 3.0 to 3.4 V power supplied to the VBAT input, memory data is retained in the SRAM array and all existing interface and operating mode information is retained.

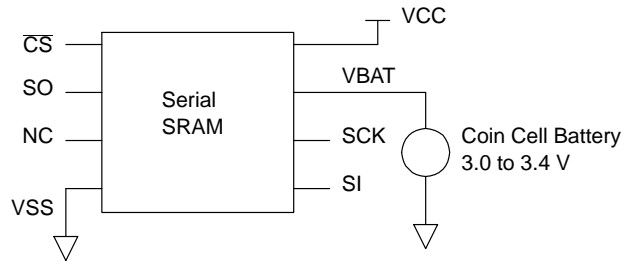

Figure 15. Battery Back-Up Version Schematics

Table 6. ABSOLUTE MAXIMUM RATINGS

Item	Symbol	Rating	Units
Voltage on any pin relative to V_{SS}	$V_{IN,OUT}$	-0.3 to $V_{CC} + 0.3$	V
Voltage on V_{CC} Supply Relative to V_{SS}	V_{CC}	-0.3 to 5.5	V
Power Dissipation	P_D	500	mW
Storage Temperature	T_{STG}	-40°C to 125°C	°C
Ambient Temperature Under Bias	T_A	-40°C to +125°C	°C
Soldering Temperature and Time	T_{SOLDER}	260°C, 10 sec	°C

Stresses exceeding those listed in the Maximum Ratings table may damage the device. If any of these limits are exceeded, device functionality should not be assumed, damage may occur and reliability may be affected.

Table 7. OPERATING CHARACTERISTICS (Industrial (I): $T_A = -40^\circ\text{C}$ to $+85^\circ\text{C}$, Automotive (E): $T_A = -40^\circ\text{C}$ to $+125^\circ\text{C}$)

Item	Symbol	Test Conditions	Min	Typ (Note 1)	Max	Units
Supply Voltage	V_{CC}		2.5		5.5	V
Data Retention Voltage	V_{DR}		1.0			V
Input High Voltage	V_{IH}		$0.7 V_{CC}$		$V_{CC} + 0.3$	V
Input Low Voltage	V_{IL}		-0.3		$0.1 V_{CC}$	V
Output High Voltage	V_{OH}	$I_{OH} = -0.4 \text{ mA}$	$V_{CC} - 0.2$			V
Output Low Voltage	V_{OL}	$I_{OL} = 1 \text{ mA}$			0.2	V
Input Leakage Current	I_{LI}	$\overline{CS} = V_{CC}, V_{IN} = 0 \text{ to } V_{CC}$			1.0	μA
Output Leakage Current	I_{LO}	$\overline{CS} = V_{CC}, V_{OUT} = 0 \text{ to } V_{CC}$			1.0	μA
Operating Current	I_{CC}	$f = 20 \text{ MHz}, I_{OUT} = 0, \text{ SPI / DUAL}$			10	mA
		$f = 20 \text{ MHz}, I_{OUT} = 0, \text{ QUAD}$			20	
Standby Current	I_{SB}	$\overline{CS} = V_{CC}, V_{IN} = V_{SS} \text{ or } V_{CC}, \text{ I-Temp}$		4	10	μA
		$\overline{CS} = V_{CC}, V_{IN} = V_{SS} \text{ or } V_{CC}, \text{ E-Temp}$			20	

1. Typical values are measured at $V_{CC} = V_{CC} \text{ Typ.}, T_A = 25^\circ\text{C}$ and are not 100% tested.

N01S830HA, N01S830BA

Table 8. CAPACITANCE (Note 2)

Item	Symbol	Test Conditions	Min	Max	Units
Input Capacitance	C_{IN}	$V_{IN} = 0\text{ V}, f = 1\text{ MHz}, T_A = 25^\circ\text{C}$		7	pF
I/O Capacitance	$C_{I/O}$	$V_{IN} = 0\text{ V}, f = 1\text{ MHz}, T_A = 25^\circ\text{C}$		7	pF

2. These parameters are verified in device characterization and are not 100% tested.

Table 9. TIMING TEST CONDITIONS

Item	Value
Input Pulse Level	$0.1 V_{CC}$ to $0.9 V_{CC}$
Input Rise and Fall Time	5 ns
Input and Output Timing Reference Levels	$0.5 V_{CC}$
Output Load	$CL = 30\text{ pF}$
Operating Temperature	Industrial (I): -40°C to $+85^\circ\text{C}$
	Automotive (E): -40°C to $+125^\circ\text{C}$

Table 10. TIMING

Characteristic	Symbol	I-Temp		E-Temp		Units
		Min	Max	Min	Max	
Clock Frequency	f_{CLK}		20		16	MHz
Clock Rise Time	t_R		20		20	ns
Clock Fall Time	t_F		20		20	ns
Clock High Time	t_{HI}	25		32		ns
Clock Low Time	t_{LO}	25		32		ns
Clock Delay Time	t_{CLD}	25		32		ns
CS Setup Time	t_{CSS}	25		32		ns
CS Hold Time	t_{CSH}	50		50		ns
CS Disable Time	t_{CSD}	25		32		ns
SCK to CS	t_{SCS}	5		5		ns
Data Setup Time	t_{SU}	10		10		ns
Data Hold Time	t_{HD}	10		10		ns
Output Valid From Clock Low	t_V		25		32	ns
Output Hold Time	t_{HO}	0		0		ns
Output Disable Time	t_{RDIS}		20		20	ns
HOLD Setup Time	t_{HS}	10		10		ns
HOLD Hold Time	t_{HH}	10		10		ns
HOLD Low to Output High-Z	t_{HZ}	10		10		ns
HOLD High to Output Valid	t_{HV}		50		50	ns

N01S830HA, N01S830BA

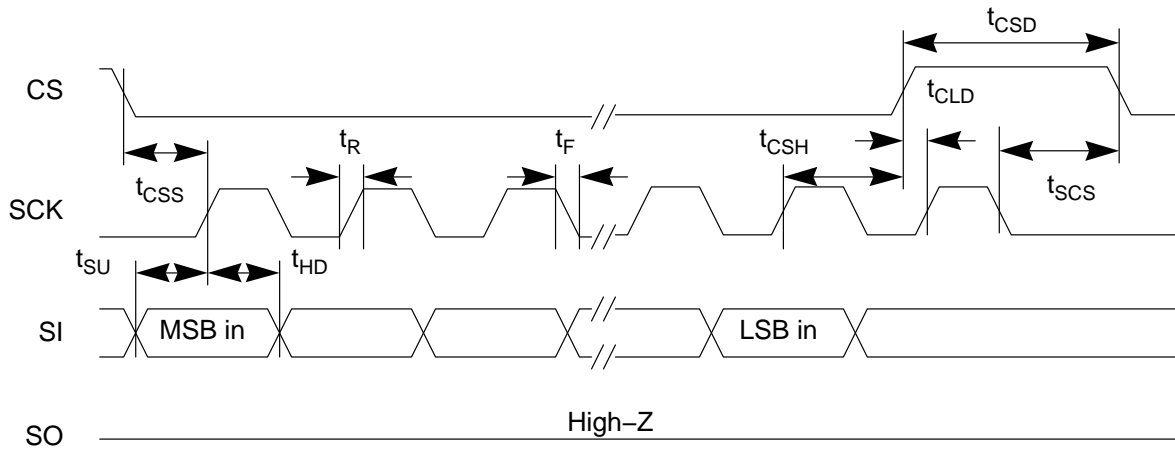

Figure 16. SPI Input Timing

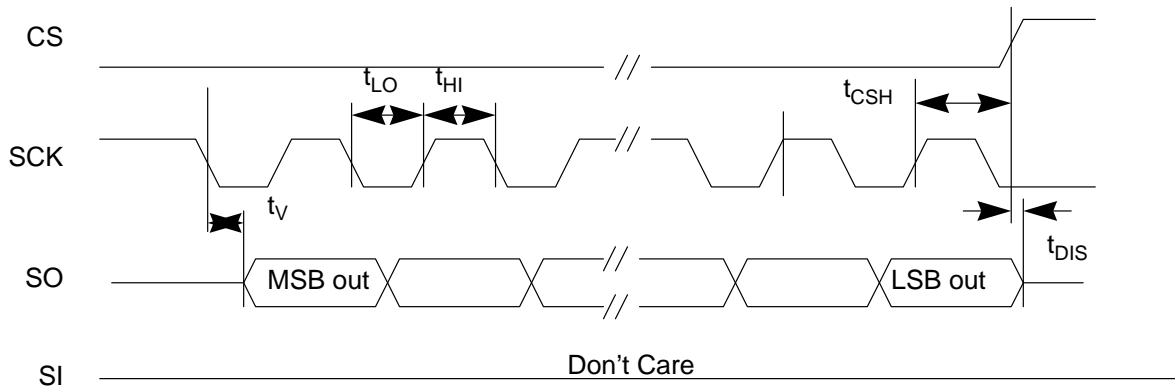

Figure 17. SPI Output Timing

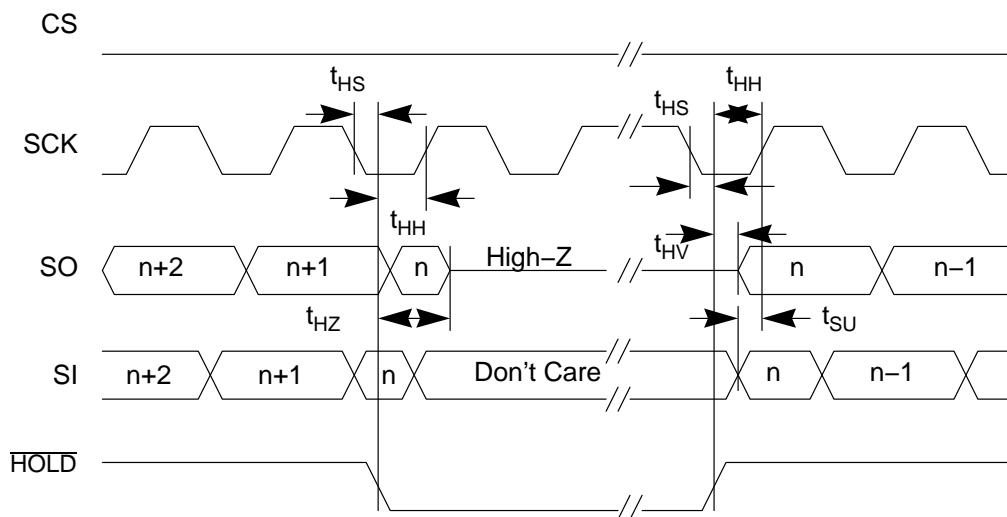

Figure 18. SPI Hold Timing

N01S830HA, N01S830BA

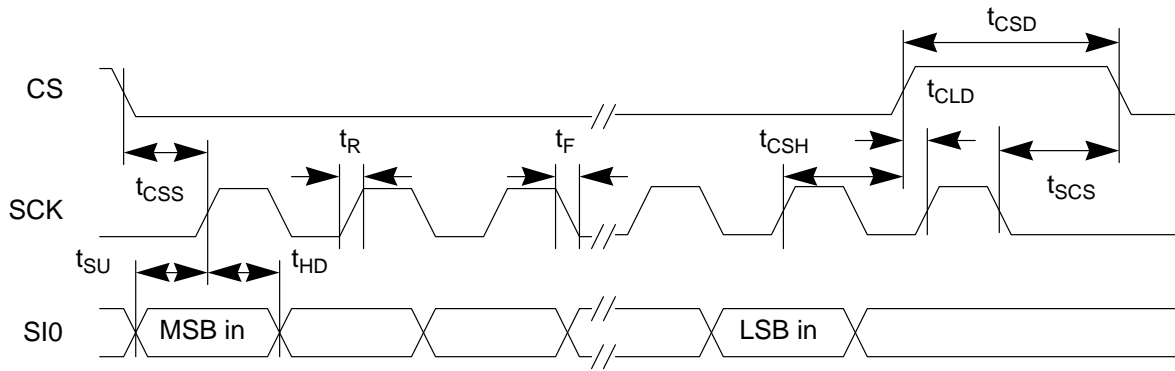

Figure 19. QUAD Input Timing

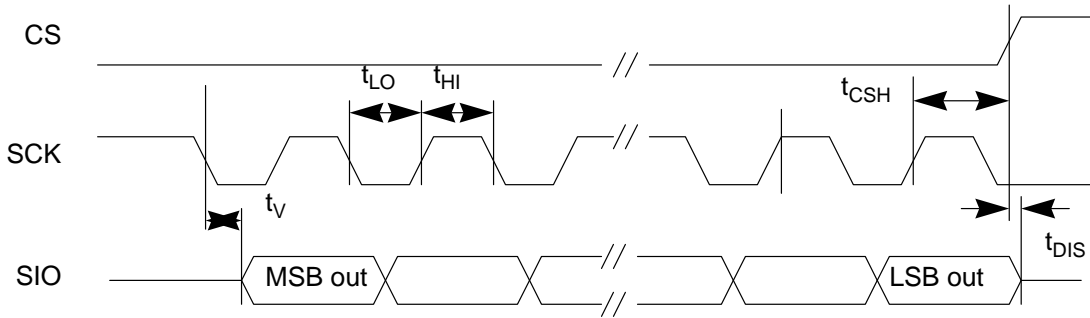
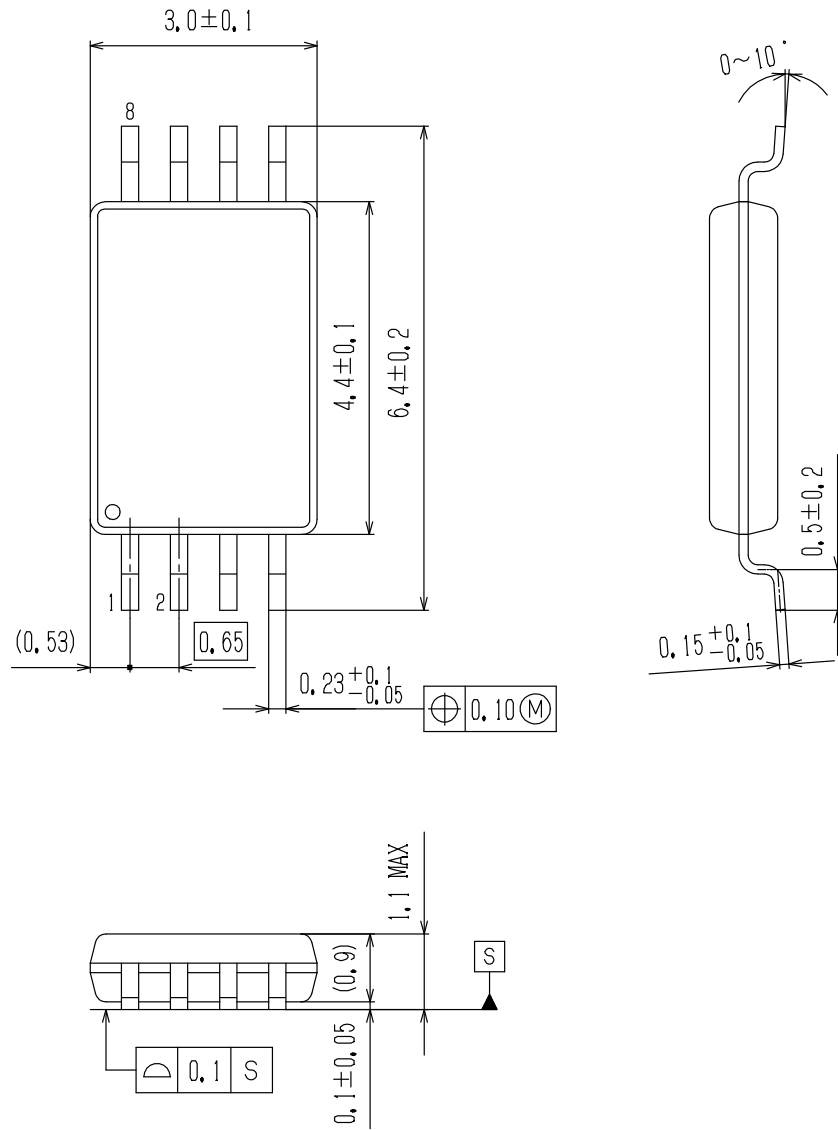



Figure 20. QUAD Output Timing

N01S830HA, N01S830BA

PACKAGE DIMENSIONS

TSSOP8 3x4.4 / TSSOP8 (225 mil)
CASE 948BH
ISSUE O



ON Semiconductor and the  are registered trademarks of Semiconductor Components Industries, LLC (SCILLC) or its subsidiaries in the United States and/or other countries. SCILLC owns the rights to a number of patents, trademarks, copyrights, trade secrets, and other intellectual property. A listing of SCILLC's product/patent coverage may be accessed at www.onsemi.com/site/pdf/Patent-Marking.pdf. SCILLC reserves the right to make changes without further notice to any products herein. SCILLC makes no warranty, representation or guarantee regarding the suitability of its products for any particular purpose, nor does SCILLC assume any liability arising out of the application or use of any product or circuit, and specifically disclaims any and all liability, including without limitation special, consequential or incidental damages. "Typical" parameters which may be provided in SCILLC data sheets and/or specifications can and do vary in different applications and actual performance may vary over time. All operating parameters, including "Typicals" must be validated for each customer application by customer's technical experts. SCILLC does not convey any license under its patent rights nor the rights of others. SCILLC products are not designed, intended, or authorized for use as components in systems intended for surgical implant into the body, or other applications intended to support or sustain life, or for any other application in which the failure of the SCILLC product could create a situation where personal injury or death may occur. Should Buyer purchase or use SCILLC products for any such unintended or unauthorized application, Buyer shall indemnify and hold SCILLC and its officers, employees, subsidiaries, affiliates, and distributors harmless against all claims, costs, damages, and expenses, and reasonable attorney fees arising out of, directly or indirectly, any claim of personal injury or death associated with such unintended or unauthorized use, even if such claim alleges that SCILLC was negligent regarding the design or manufacture of the part. SCILLC is an Equal Opportunity/Affirmative Action Employer. This literature is subject to all applicable copyright laws and is not for resale in any manner.

PUBLICATION ORDERING INFORMATION

LITERATURE FULFILLMENT:
Literature Distribution Center for ON Semiconductor
19521 E. 32nd Pkwy, Aurora, Colorado 80011 USA
Phone: 303-675-2175 or 800-344-3860 Toll Free USA/Canada
Fax: 303-675-2176 or 800-344-3867 Toll Free USA/Canada
Email: orderlit@onsemi.com

N. American Technical Support: 800-282-9855 Toll Free
USA/Canada
Europe, Middle East and Africa Technical Support:
Phone: 421 33 790 2910
Japan Customer Focus Center
Phone: 81-3-5817-1050

ON Semiconductor Website: www.onsemi.com
Order Literature: <http://www.onsemi.com/orderlit>
For additional information, please contact your local
Sales Representative

Looking for pricing, stock, or lifecycle information?

Click below to explore more details on WIN SOURCE:

 [View N01S830BAT22IT](#) on WIN SOURCE

 [ON Semiconductor](#) Information

Optimize Your Supply Chain with WIN SOURCE Solutions

-  Global Sourcing Solution
-  Obsolete Management
-  Cost Control Management
-  Shortage Management
-  Alternative Solution
-  Excess Inventory Management