



# Type EDLR, Long Life Electric Double Layer Ultracapacitor



Type EDLR electric double layer supercapacitors offer high capacitance values in a thru hole stacked coin type package. Primarily designed for integrated circuit voltage backup, the capacitors can also be used to deliver the initial power from batteries.

## Highlights

- Long life
- High discharge current
- 85 °C Operating temperature

## Specifications

Operating Temperature Range	-25 °C to +85 °C
Rated Voltage Range	3.6 Vdc to 5.5 Vdc
Capacitance Range	0.1 F to 1.0 F

Type	RF	RD	RG
Capacitance (F)	0.10	0.68	1.0
Voltage (Vdc)	5.5		3.6
Capacitance Tolerance (%)	-20 to +80		
Max. Initial Internal Resistance (ohms at 1kHz)	75	20	20
Life, Moisture and Temperature Characteristics	After the following procedures have been performed, measure the capacitance and internal resistance at +20 °C.		
Life Test:	Apply the max. operating voltage for 2000 h at +85 °C		
Capacitance Change	±30% of the initial measured value at +20 °C		
Internal Resistance	2 times the initial specified value		
Shelf Life:	Subject the capacitor to 2000 hours without voltage at +85 °C.		
Capacitance Change	±30% of the initial measured value at +20 °C		
Internal Resistance	2 times the initial specified value		
Moisture Resistance:	Subject the capacitor to 500 hours at +55 °C at 90 to 95% RH without voltage.		
Capacitance Change	±10% of the initial measured value at +20 °C		
Internal Resistance	meets the initial specified value		
Soldering Heat Resistance:	Immerse the capacitor leads to within 2 mm of the capacitor body in solder that is at a temperature of 260 °C for 10 seconds.		
Capacitance Change	±10% of the initial measured value at +20 °C		
Internal Resistance	meets the initial specified value		

Temperature Cycling	Stabilize the capacitor at each of the following temperatures for 1 hour in sequence, and then measure the capacitance and internal resistance at that temperature.
	<ol style="list-style-type: none"> <li>+20 °C</li> <li>-25 °C</li> <li>+20 °C</li> <li>+85 °C</li> <li>+20 °C</li> </ol>
Capacitance Change (at -25 °C)	±30% of the initial measured value at +20 °C
Internal resistance (at -25 °C)	5 times the initial measured value at +20 °C
Capacitance Change (at +85 °C)	±30% of the initial measured value at +20 °C
Internal resistance (at +85 °C)	4 times the initial measured value at +20 °C
Capacitance Change (Step 5 at +20 °C)	±10% of the initial measured value at +20 °C
Internal resistance (Step 5 at +20 °C)	meets the initial specified value

RoHS Compliant

# Type EDLR, Long Life Electric Double Layer Ultracapacitor

## Ratings

Catalog Part Number	Capacitance (F)	Voltage (Vdc)	Max. Resistance @ 1 kHz ( )	Case Type	Case Dia. (mm)	Case Height (mm)	Lead Spacing	Max. Discharge Current (ma)	Weight (g)	Pkg Qty (pcs)
EDLRF104A5R5C	0.10	5.5	75	Stacked Coin	13.5	9.5	5	3	3.3	200
EDLRF684B5R5C	0.68		20		21.5			20	4.1	100*
EDLRD224H3R6C	0.22	3.6	50	Stacked Coin	10.5	6.0	10	1	1.0	200
EDLRD224V3R6C						11.5	5			
EDLRG105H3R6C	1.0	3.6	20	Stacked Coin	19.0	6.5	20	20	4.1	100*
EDLRG105V3R6C						21.0	5			

Note: Pkg is bulk except \* items are in trays.

## Part Numbering System

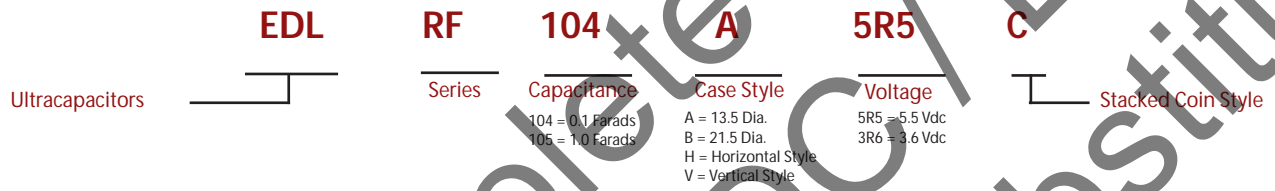

## EDLRF Outline Drawing

### Stacked Coin

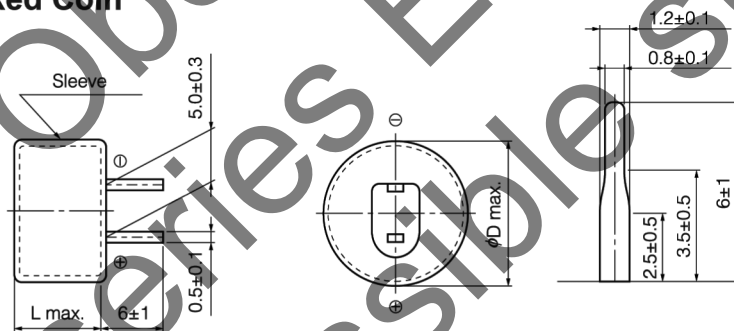

Capacitance (F)	D (mm)	L (mm)
0.1	13.5	9.5
0.68	21.5	9.5

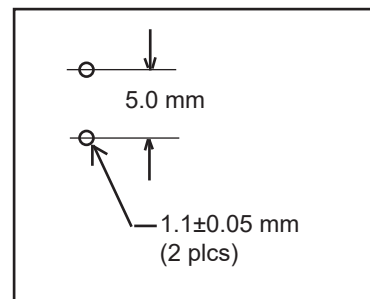

Recommended Printed Circuit Board Hole Pattern

# Type EDLR, Long Life Electric Double Layer Ultracapacitor

## EDLRD Outline Drawing

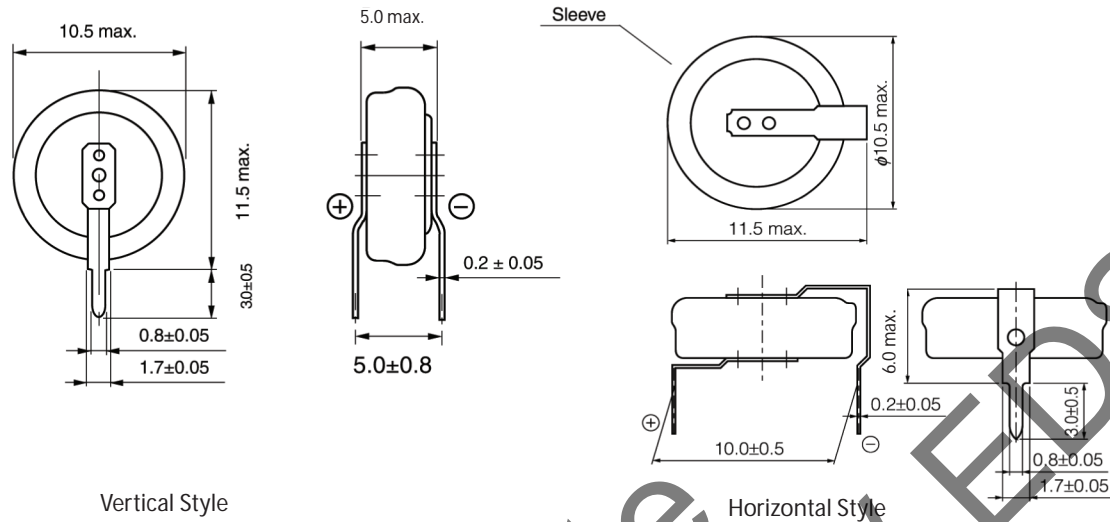

Vertical Style

Horizontal Style

## EDLRG Outline Drawing

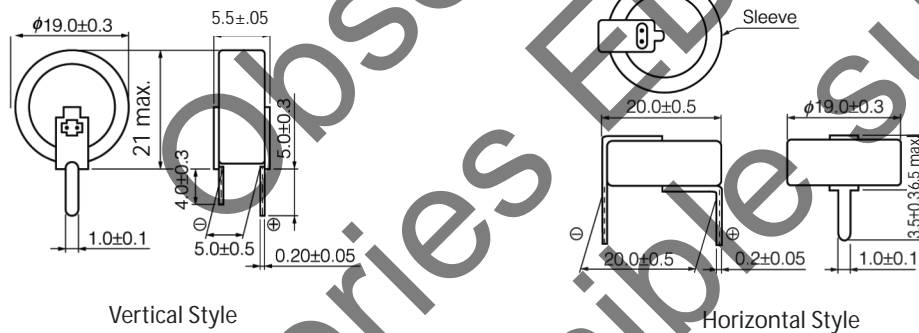

Vertical Style

Horizontal Style

### Recommended Soldering Procedures

Hand Soldering	Use a 30W iron with a max. temperature of 350 °C for 4 seconds.
Wave Soldering	Pre-heat circuit board to a surface temp of 110 °C for a max. of 60 seconds, with a max. component temperature of 100 °C. Min. printed circuit board thickness of 0.8 mm. Recommended solder bath temperature of 240 °C with a max. dipping time of 5 seconds.

**Notice and Disclaimer:** All product drawings, descriptions, specifications, statements, information and data (collectively, the "Information") in this datasheet or other publication are subject to change. The customer is responsible for checking, confirming and verifying the extent to which the Information contained in this datasheet or other publication is applicable to an order at the time the order is placed. All Information given herein is believed to be accurate and reliable, but it is presented without any guarantee, warranty, representation or responsibility of any kind, expressed or implied. Statements of suitability for certain applications are based on the knowledge that the Cornell Dubilier company providing such statements ("Cornell Dubilier") has of operating conditions that such Cornell Dubilier company regards as typical for such applications, but are not intended to constitute any guarantee, warranty or representation regarding any such matter – and Cornell Dubilier specifically and expressly disclaims any guarantee, warranty or representation concerning the suitability for a specific customer application, use, storage, transportation, or operating environment. The Information is intended for use only by customers who have the requisite experience and capability to determine the correct products for their application. Any technical advice inferred from this Information or otherwise provided by Cornell Dubilier with reference to the use of any Cornell Dubilier products is given gratis (unless otherwise specified by Cornell Dubilier), and Cornell Dubilier assumes no obligation or liability for the advice given or results obtained. Although Cornell Dubilier strives to apply the most stringent quality and safety standards regarding the design and manufacturing of its products, in light of the current state of the art, isolated component failures may still occur. Accordingly, customer applications which require a high degree of reliability or safety should employ suitable designs or other safeguards (such as installation of protective circuitry or redundancies or other appropriate protective measures) in order to ensure that the failure of an electrical component does not result in a risk of personal injury or property damage. Although all product-related warnings, cautions and notes must be observed, the customer should not assume that all safety measures are indicated in such warnings, cautions and notes, or that other safety measures may not be required.

Obsolète EDC V125  
See series EDC V125  
for a possible substitute

## Looking for pricing, stock, or lifecycle information?

Click below to explore more details on WIN SOURCE:

- ⊖ [View EDLRD224H3R6C on WIN SOURCE](#)
- ⊖ [Cornell Dubilier Electronics \(CDE\) Information](#)

## Optimize Your Supply Chain with WIN SOURCE Solutions

- ✓ Global Sourcing Solution
- ✓ Obsolete Management
- ✓ Cost Control Management
- ✓ Shortage Management
- ✓ Alternative Solution
- ✓ Excess Inventory Management