



**THE DATASHEET OF
AP74700QW6-7**



**±65V REVERSE VOLTAGE PROTECTION
AUTOMOTIVE-COMPLIANT IDEAL DIODE CONTROLLER**

Description

The DIODES™ AP74700Q is an automotive-compliant ideal diode MOSFET controller, which when used with an appropriate external N-channel power MOSFET provides a low-loss 20mV forward voltage drop rectifier in unidirectional power paths as well as reverse voltage.

AP74700Q supports wide input operation range from 3.2V to 65V, allowing control of many popular DC rail voltage such as 12V, 24V or higher automotive battery systems. The 3.2V input voltage support fits for severe cold crank requirements in automotive systems. The AP74700Q can withstand and protect the loads from reverse voltages down to -65V.

AP74700Q, with its built-in charge pump, controls the GATE of MOSFET to regulate the MOSFET's forward voltage drop to around 20mV. Its internal gate driver quickly turns off the MOSFET during a reverse current event and ensures there is no DC reverse current flow. Fast reverse current blocking response of < 0.75µs makes it suitable for systems with output voltage holdup requirements during ISO 7637 pulse testing, as well as power fail and input micro-short conditions.

The high 65V voltage rating of AP74700Q simplifies the system design for automotive ISO 7637 protection. With the enable pin low, the controller is off and draws about typical 0.7µA of current.

The AP74700Q is available in SOT26 package.

Applications

- Automotive infotainment systems - clusters
- Automotive ADAS systems - cameras
- Automotive lighting systems
- Automotive power trains

Pin Assignments

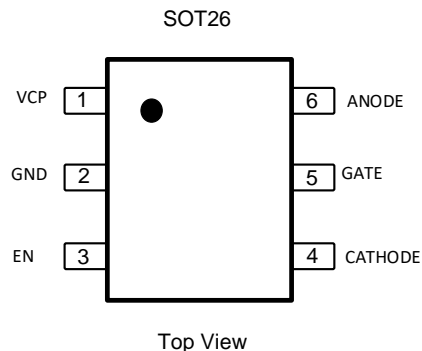

Features

- Input Voltage Ranges from 3.2V to 65V (3.9V Start-up)
- -65V Reverse Battery Voltage
- Charge Pump for External N-Channel Power MOSFET
- 20mV ANODE to CATHODE Forward Voltage Drop Control
- Low Shutdown Current of 0.7µA when Disabled
- Low Quiescent Current of 80µA when Enabled
- Fast Reverse Current Block Response Time of < 0.75µs
- Active High Enable Operation
- ESD Protection 2kV of HBM and 1.5kV of CDM
- AEC-Q100 Qualification with Device Temperature Grade 1 (-40°C to +125°C Ambient Operating Temperature Range)
- Compliant with Automotive Transient Requirements with Appropriate TVS
 - ISO 7637-2 Transient Pulses
 - ISO 16750-2 Load Dump Suppression
- 6-Pin SOT26 Package
- **Totally Lead-Free & Fully RoHS Compliant (Notes 1 & 2)**
- **Halogen and Antimony Free. "Green" Device (Note 3)**
- **The AP74700Q is suitable for automotive applications requiring specific change control; this part is AEC-Q100 qualified, PPAP capable, and manufactured in IATF16949 certified facilities.**

<https://www.diodes.com/quality/product-definitions/>

Notes: 1. No purposely added lead. Fully EU Directive 2002/95/EC (RoHS), 2011/65/EU (RoHS 2) & 2015/863/EU (RoHS 3) compliant.
 2. See <https://www.diodes.com/quality/lead-free/> for more information about Diodes Incorporated's definitions of Halogen- and Antimony-free, "Green" and Lead-free.
 3. Halogen- and Antimony-free "Green" products are defined as those which contain <900ppm bromine, <900ppm chlorine (<1500ppm total Br + Cl) and <1000ppm antimony compounds.

Typical Applications Circuit

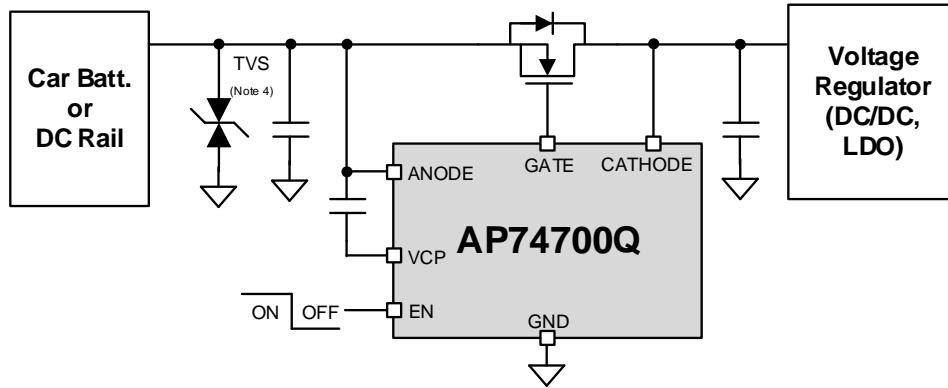

Note: 4. Appropriate TVS is required to meet ISO 7632-2 and ISO 16750-2 requirements for automotive applications.

Pin Descriptions

Pin Name	Pin Number	Function
VCP	1	Charge pump voltage output pin. Connects to external capacitor.
GND	2	Ground pin.
EN	3	Enable pin. Active high.
CATHODE	4	CATHODE pin. Connects to the drain of external MOSFET.
GATE	5	Gate driver out pin. Connects to gate of external MOSFET.
ANODE	6	Input supply and ANODE pin. Connects to the source of external MOSFET.

Functional Block Diagram

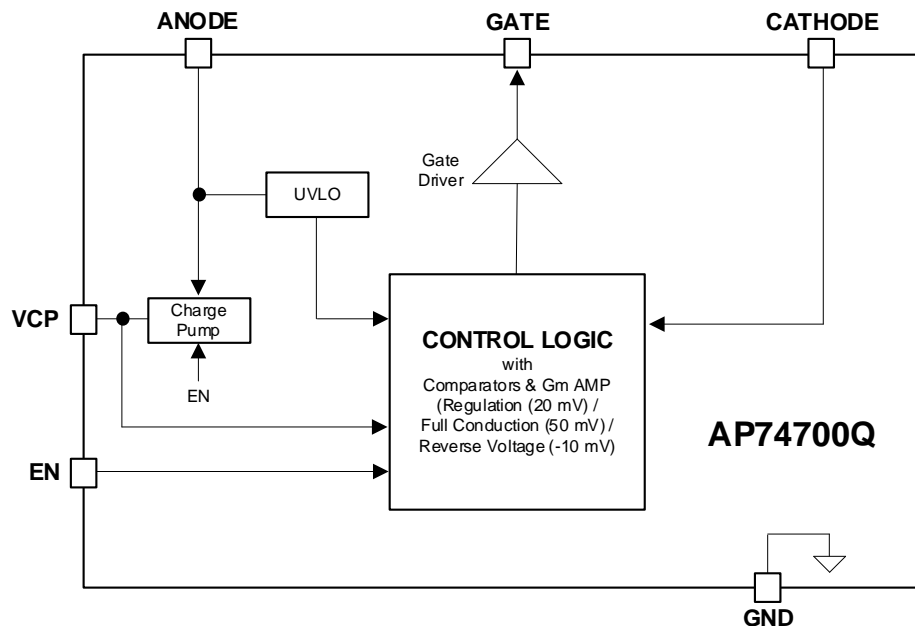

Absolute Maximum Ratings (@T_A = +25°C, unless otherwise specified.) (Note 5)

Symbol	Parameter	Ratings	Unit
ANODE to GND	Input Voltage at ANODE	-65 to +65	V
EN to GND	ANODE > 0V	-0.3 to +65	V
	ANODE ≤ 0V	ANODE to 65 + ANODE	V
GATE to ANODE	Gate to ANODE Voltage	-0.3 to +15	V
VCP to ANODE	Charge Pump Voltage	-0.3 to +15	V
CATHODE to ANODE	CATHODE to ANODE Voltage	-5 to 75	V
T _{J(max)}	Maximum Junction Temperature	-40 to +150	°C
T _{STG}	Storage Temperature	-40 to +150	°C
R _{θJA}	Junction-to-Ambient Thermal Resistance (Note 6)	130	°C/W
R _{θJC(top)}	Junction-to-Case (Top) Thermal Resistance (Note 6)	65	°C/W
ESD HBM	Human Body ESD Protection	±2	kV
ESD CDM	Charged Device Model ESD Protection	±1.5	kV

- Notes:
- Stresses greater than those listed under *Absolute Maximum Ratings* can cause permanent damage to the device. These are stress ratings only, and functional operation of the device at these or any other conditions beyond those indicated under *Recommended Operating Conditions* is not implied. Exposure to *Absolute Maximum Ratings* for extended periods can affect device reliability.
 - R_{θJA} and R_{θJC} are measured at T_A = +25°C on a high effective thermal conductivity four-layer test board per JEDEC 51-7.

Recommended Operating Conditions (@T_A = +25°C, unless otherwise specified.)

Symbol	Parameter	Min	Max	Unit
ANODE to GND	Input Voltage at ANODE	-60	+60	V
CATHODE to GND	Input Voltage at CATHODE	—	+60	V
EN to GND	Enable Pin	-60	+60	V
CATHODE to ANODE	CATHODE to ANODE Voltage	—	70	V
Anode Cap	Input Capacitor (Note 7)	22	—	nF
Cathode Cap	Output Capacitor (Note 7)	1	—	µF
VCP to Anode Cap	Charge Pump Capacitor (Note 7)	0.1	—	µF
External MOSFET VGS Max	Gate to Anode (Note 7)	15	—	V
T _A	Operating Ambient Temperature Range	-40	+125	°C

- Note: 7. Refer to the typical application circuit.

Electrical Characteristics

($T_J = -40^\circ\text{C}$ to $+125^\circ\text{C}$, $V_{\text{ANODE}} = 12\text{V}$, $C_{\text{VCP}} = 0.1\mu\text{F}$, $V_{\text{EN}} = 5.0\text{V}$, typical values are at $T_J = +25^\circ\text{C}$, unless otherwise specified.)

Symbol	Parameter	Conditions	Min	Typ	Max	Unit
VANODE Supply						
V_{ANODE}	Operating Input Voltage	—	4	—	60	V
$V_{\text{UVLO_ANODE}}$	ANODE UVLO Rising Threshold	—	—	—	3.9	V
	ANODE UVLO Falling Threshold	—	2.2	2.8	3.1	V
$V_{\text{UVLO_ANODE_Hys}}$	ANODE UVLO Hysteresis	—	440	—	670	mV
$I_{\text{ANODE_OFF}}$	Shutdown Supply Current	$V_{\text{EN}} = 0\text{V}$	—	0.7	1.9	μA
$I_{\text{ANODE_Q}}$	Operating Quiescent Current	—	—	80	205	μA
EN Input						
$V_{\text{IL_EN}}$	Enable Input Low Threshold	—	0.6	1.05	1.45	V
$V_{\text{IH_EN}}$	Enable Input High Threshold	—	1.3	2.3	2.9	V
$V_{\text{HYS_EN}}$	Enable Hysteresis	—	0.52	—	1.50	V
I_{EN}	Enable Sink Current	$V_{\text{EN}} = 12\text{V}$	—	3	5	μA
VANODE and VCATHODE by Operation Modes						
$V_{\text{ACTIVE_REG}}$	Regulated Forward Threshold	—	11	20	29	mV
$V_{\text{ACTIVE_FULL}}$	Threshold for Full Conduction Mode	—	34	50	57	mV
$V_{\text{ACTIVE_REV}}$	Threshold for Reverse Current Blocking	—	-17	-10	-2	mV
G_m	Regulation Error AMP Transconductance (Note 8)	—	1000	1650	2200	$\mu\text{A/V}$
Gate Drive						
I_{GATE}	Peak Source Current	$V_{\text{ANODE}} - V_{\text{CATHODE}} = 100\text{mV}$ $V_{\text{GATE}} - V_{\text{ANODE}} = 5\text{V}$	3	11	—	mA
	Peak Sink Current	$V_{\text{ANODE}} - V_{\text{CATHODE}} = -20\text{mV}$ $V_{\text{GATE}} - V_{\text{ANODE}} = 5\text{V}$	—	1850	—	mA
	Regulation Max Sink Current	$V_{\text{ANODE}} - V_{\text{CATHODE}} = 0\text{V}$ $V_{\text{GATE}} - V_{\text{ANODE}} = 5\text{V}$	—	18	—	μA
R_{DIS}	Discharge Switch Resistance	$V_{\text{ANODE}} - V_{\text{CATHODE}} = -20\text{mV}$ $V_{\text{GATE}} - V_{\text{ANODE}} = 5\text{V}$	0.4	—	2	Ω

Note: 8. Parameter guaranteed by design and characterization.

Electrical Characteristics (continued)

 (T_J = -40°C to +125°C, V_{ANODE} = 12V, C_{VCP} = 0.1μF, V_{EN} = 5.0V, typical values are at T_J = +25°C, unless otherwise specified.)

Symbol	Parameter	Conditions	Min	Typ	Max	Unit
Charge Pump						
I _{VCP}	Charge Pump Source Current (Charge Pump On)	V _{VCP} – V _{ANODE} = 7V	160	220	600	μA
	Charge Pump Sink Current (Charge Pump Off)	V _{VCP} – V _{ANODE} = 14V	—	6	10	μA
V _{VCP} – V _{ANODE}	Charge Pump Voltage at V _{ANODE} = 3.2V	I _{VCP} ≤ 30μA	8	—	—	V
	Charge Pump Turn On Voltage	—	11	12	13	V
	Charge Pump Turn Off Voltage	—	12	13	14	V
	Charge Pump Enable Comparator Hysteresis	—	0.5	1	1.7	V
V _{VCP_UVLO}	V _{VCP} – V _{ANODE} UV Release at Rising Edge	V _{ANODE} – V _{CATHODE} = 100mV	5.8	6.6	7.7	V
	V _{VCP} – V _{ANODE} UV Threshold at Falling Edge	V _{ANODE} – V _{CATHODE} = 100mV	4.6	5.4	6	V
CATHODE						
I _{CATHODE}	CATHODE Sink Current	V _{ANODE} = 12V V _{ANODE} – V _{CATHODE} = -100mV	—	1.4	2	μA
		V _{ANODE} – V _{CATHODE} = 100mV	—	1.0	2.2	μA
		V _{ANODE} = -12V, V _{CATHODE} = 12V	—	1.25	4.7	μA

Switching Characteristics

 (T_J = -40°C to +125°C, V_{ANODE} = 12V, C_{VCP} = 0.1μF, V_{EN} = 5.0V, typical values are at T_J = +25°C, unless otherwise specified.)

Symbol	Parameter	Conditions	Min	Typ	Max	Unit
Switching Characteristics						
t _{EN_DELAY}	Delay from Enable Switching High to Gate Turn On	V _{VCP} > V _{VCP_UVLO}	—	70	150	μs
t _{REV_GATE}	Gate Turn Off Time when Reverse Voltage is Detected (Note 9)	V _{ANODE} – V _{CATHODE} = 100mV to -100mV	—	0.45	0.75	μs
t _{FWD_GATE}	Gate Turn On Time when Forward Conducting Voltage Detected (Note 9)	V _{ANODE} – V _{CATHODE} = -100mV to 700mV	—	1.4	2.5	μs

Note: 9. Parameter guaranteed by bench characterization.

Typical Performance Characteristics

($V_{ANODE} = 12V$, $V_{EN} = High$, $C_{VCP} = 0.1\mu F$, $T_J = +25^\circ C$, unless otherwise specified.)

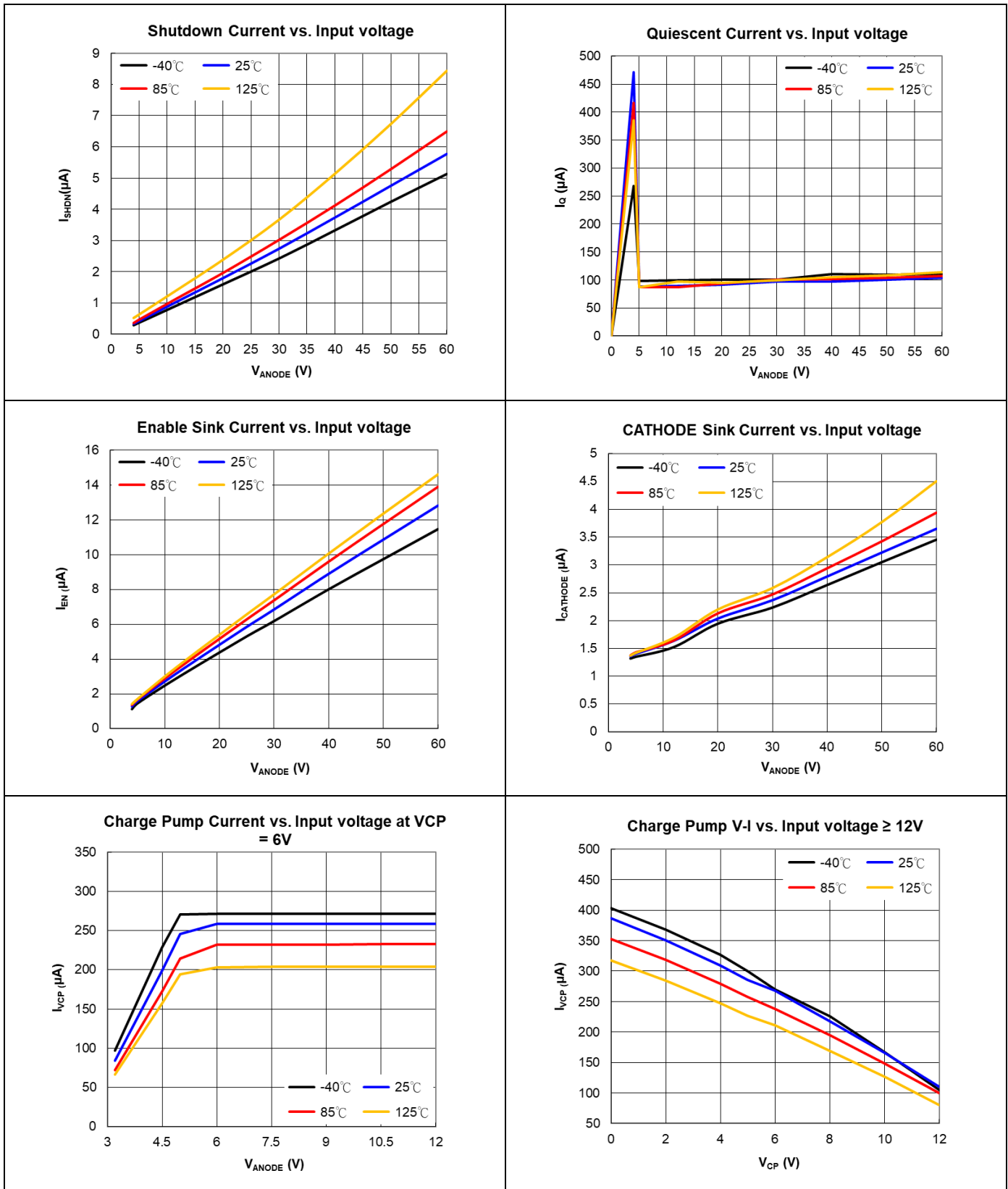

Typical Performance Characteristics (continued)

($V_{ANODE} = 12V$, $V_{EN} = High$, $C_{VCP} = 0.1\mu F$, $T_J = +25^\circ C$, unless otherwise specified.)

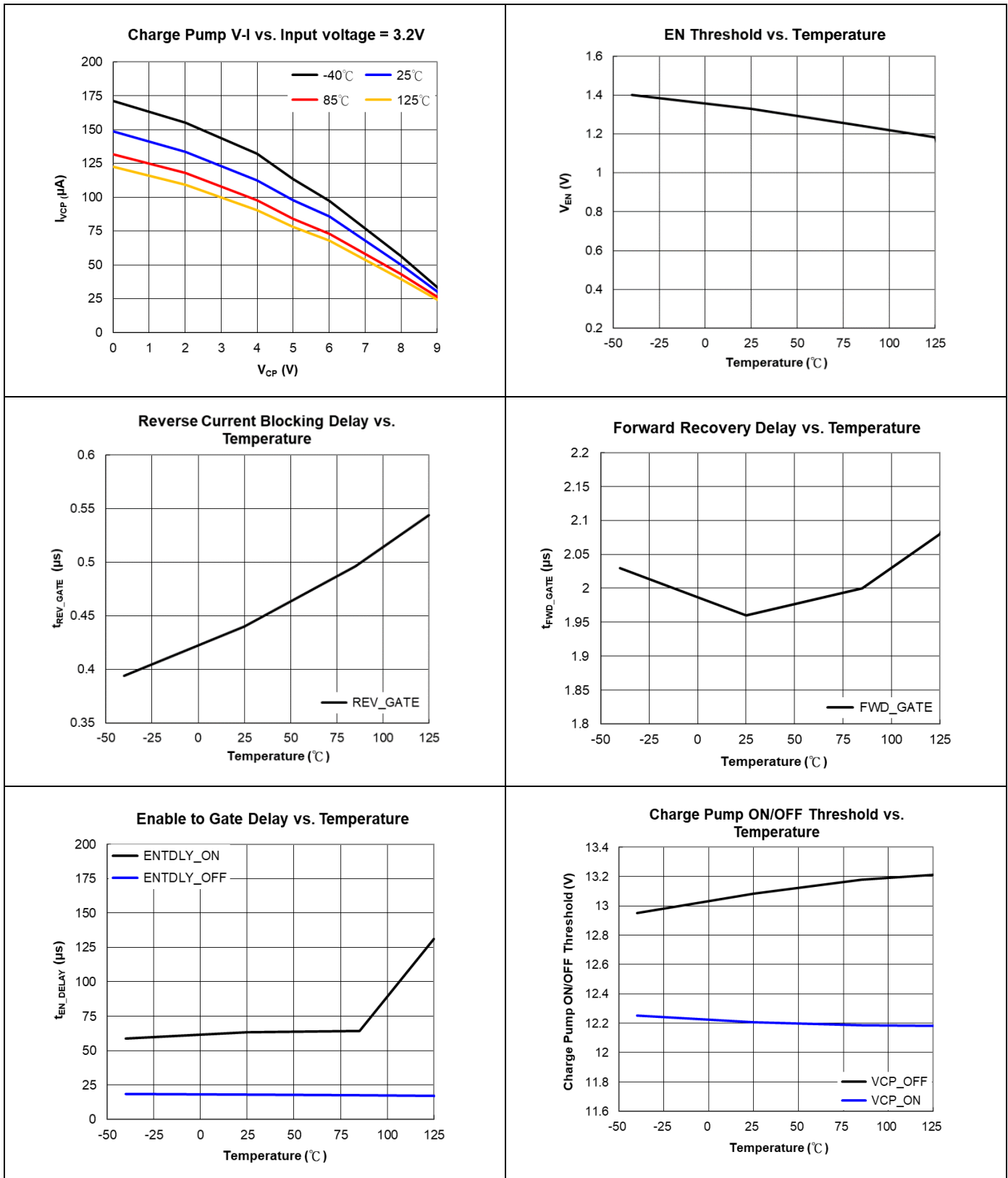

Typical Performance Characteristics (continued)

($V_{ANODE} = 12V$, $V_{EN} = High$, $C_{VCP} = 0.1\mu F$, $T_J = +25^\circ C$, unless otherwise specified.)

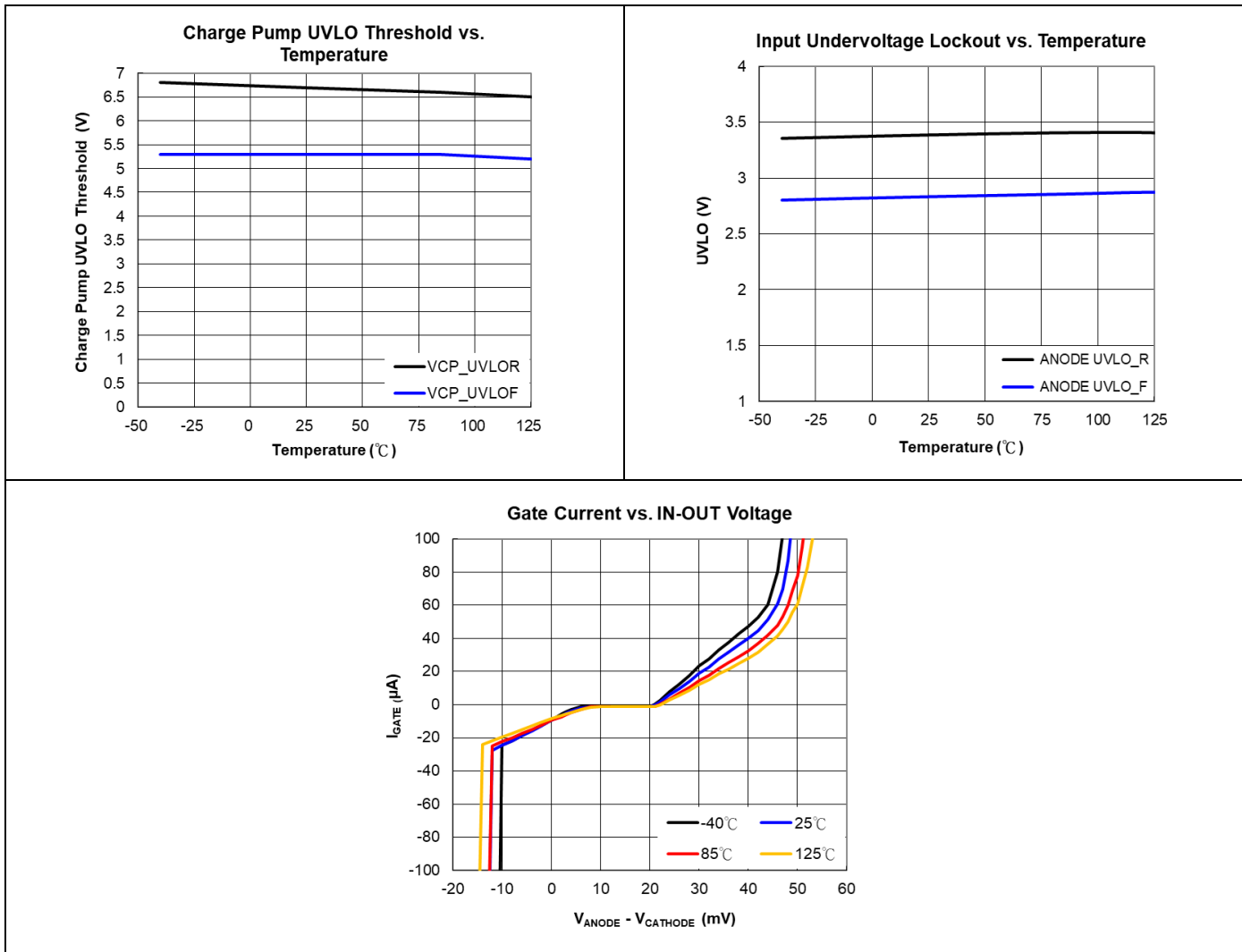

Switching Waveforms

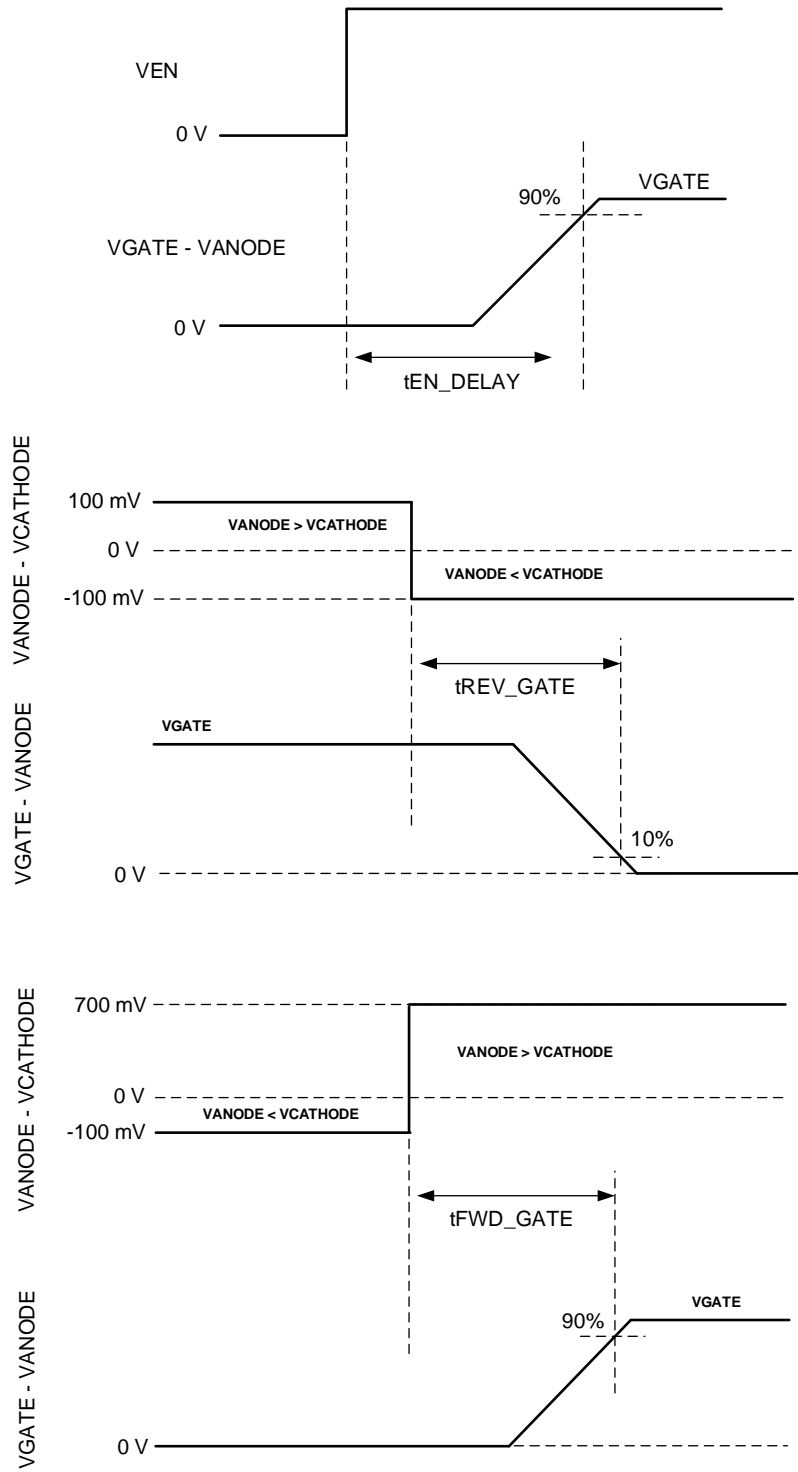

Detailed Description

Overview

The AP74700Q is a $\pm 65V$ reverse protected ideal diode controller, which can implement an efficient and fast reverse polarity protection circuit or be used in an ORing configuration. When used with a suitable external N-channel MOSFET it provides a lower loss alternative to other reverse polarity solutions such as a P-channel MOSFET or a Schottky diode. An internal charge pump is used to drive the external N-channel MOSFET to a maximum gate drive voltage of approximately 15V. The voltage drop across the MOSFET is continuously monitored between the ANODE and CATHODE pins, and the GATE to ANODE voltage is adjusted as needed to regulate the forward voltage drop at 20mV. When reverse current from ANODE to CATHODE is detected, then the MOSFET will be turned off within 0.75 μ s of fast reverse current response time by internally connecting GATE to ANODE to avoid DC reverse current flow. An enable pin, EN, when brought low places the AP74700Q into a shutdown mode which turns off the external N-channel MOSFET and minimizes the AP74700Q's standby current.

Input Voltage

The ANODE pin is used to power the AP74700Q's internal circuitry, typically drawing 80 μ A when enabled and 0.7 μ A when disabled. If the ANODE pin voltage is greater than the UVLO rising threshold, then AP74700Q operates in either shutdown mode or conduction mode in depending on the EN pin voltage. The voltage from ANODE to GND is designed to withstand 65V to -65V, allowing the AP74700Q to withstand negative voltage transients.

Charge Pump

The charge pump supplies the voltage necessary to drive the external N-channel MOSFET. An external charge pump capacitor is placed between VCP and ANODE pins to provide energy to turn on the external MOSFET. In order for the charge pump to supply current to the external capacitor, the EN pin voltage must be above the specified input high threshold, V_{IH_EN} . When enabled, the charge pump sources a charging current of 220 μ A typical. If EN pin is pulled low, then the charge pump remains disabled. To ensure that the external MOSFET can be driven above its specified threshold voltage, the VCP to ANODE voltage must be above the VCP UVLO, typically 6.6V, before the internal gate driver is enabled. Initial gate driver enable delay can be calculated with following formula.

$$T_{DRV_EN} = 70\mu s + C_{VCP} \times \frac{V_{VCP_UVLO}}{220\mu A}$$

Where,

C_{VCP} is the charge pump capacitance connected across ANODE and VCP pins

$V_{VCP_UVLO} = 6.6V$ (typical)

Typical 1V hysteresis of VCP UVLO threshold enhances linearity of gate driver. The charge pump remains enabled until the VCP to ANODE voltage reaches 13V, typically, at which point the charge pump is disabled, decreasing the current draw on the ANODE pin. The charge pump remains disabled until the VCP to ANODE voltage is below 12V typically, at which point the charge pump is enabled. The voltage between VCP and ANODE continues to charge and discharge between 12V and 13V. By enabling and disabling the charge pump, the operating quiescent current of the AP74700Q is reduced. When the charge pump is disabled, it sinks 6 μ A typical.

Gate Driver

The gate driver controls the external N-channel MOSFET by driving the GATE to ANODE voltage to the corresponding mode of operation. There are three defined modes of operation that the gate driver operates under forward regulation, full conduction mode and reverse current protection, according to the ANODE to CATHODE voltage. Its mode varies according to the ANODE to CATHODE voltage of the AP74700Q. The threshold between forward regulation mode and conduction mode is when the ANODE to CATHODE voltage is 50mV. The threshold between forward regulation mode and reverse current protection mode is when the ANODE to CATHODE voltage is -10mV.

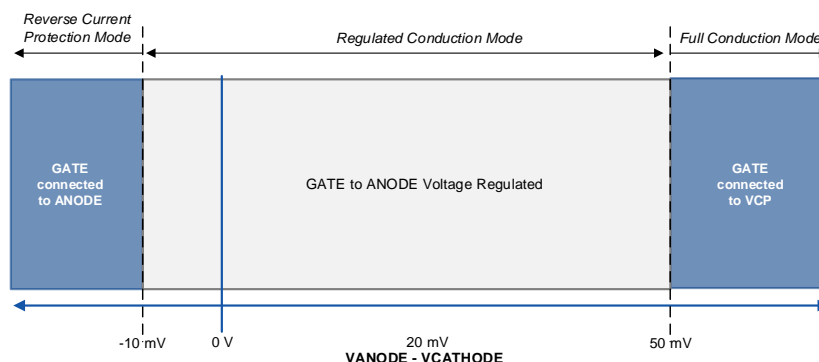

Detailed Description (continued)

Enable

The EN pin allows for the gate driver to be either enabled or disabled by an external signal. If the EN pin voltage is greater than the rising threshold, the gate driver and charge pump are activated. If the EN pin voltage is lower than the input low threshold, the charge pump and gate driver are disabled, placing the AP74700Q in shutdown mode. The EN pin can withstand a voltage as high as 65V and as low as -65V. This allows for the EN pin to be connected directly to the ANODE pin if enable functionality is not needed. In conditions where EN is left floating, the internal sink current of 3 μ A pulls EN pin low and disables the device.

Operations

AP74700Q has shutdown, regulated conduction, full conduction and reverse current protection mode in operation. Details are as follows.

VANODE	EN	VCP - VANODE	VANODE - VCATHODE	VCP	VGATE	AP74700Q Mode
-60V to 0V	Don't Care	Don't Care	Reverse Voltage	Off	NA	OFF (No Power)
0V to UVLO			Forward Voltage			Shutdown
UVLO to 60V	< VEN_IL	< VCP_UVLO	< -10mV	On	ANODE	VCP Charging
	> VEN_IH	> VCP_UVLO	-10mV to 50mV		ANODE	Reverse Current Protection
			> 50mV		Regulated	Regulated Conduction (Light Load)
			> 50mV		VCP	Full Conduction (Heavy Load)

Shutdown Mode

The AP74700Q enters shutdown mode when the EN pin voltage is below the specified input low threshold V_{IL_EN} . Both the gate driver and the charge pump are disabled in shutdown mode. During shutdown mode, the AP74700Q enters low I_Q operation with the ANODE pin only sinking 1 μ A. When the AP74700Q is in shutdown mode, forward current flow through the external MOSFET is not interrupted but is conducted through the MOSFET's body diode.

Regulated Conduction Mode

For the AP74700Q to operate in regulated conduction mode, the gate driver must be enabled and the current from source to drain of the external MOSFET must be within the range to result in an ANODE to CATHODE voltage drop of -10mV to 50mV. During forward regulation mode, the ANODE to CATHODE voltage is regulated to 20mV by adjusting the GATE to ANODE voltage. This regulation enables turning off of the MOSFET at very light loads and ensures there is no DC reverse current flow.

Full Conduction Mode

For the AP74700Q to operate in full conduction mode, the gate driver must be enabled and the current from source to drain of the external MOSFET must be large enough to result in an ANODE to CATHODE voltage drop of greater than 50mV typical. If these conditions are achieved, the GATE pin is internally connected to the VCP pin, resulting in the GATE to ANODE voltage being approximately the same as the VCP to ANODE voltage. By connecting VCP to GATE, the external MOSFET's $R_{DS(ON)}$ is minimized, reducing the power loss of the external MOSFET when forward currents are large.

Reverse Current Protection Mode

For the AP74700Q to operate in reverse current protection mode, the gate driver must be enabled and the current of the external MOSFET must be flowing from the drain to the source. When the ANODE to CATHODE voltage is typically lower than -10mV, reverse current protection mode is entered, and the GATE pin is internally connected to the ANODE pin and discharges the gate capacitance of the MOSFET turning it off. With the MOSFET being off, its body diode blocks any reverse current from flowing from the drain to source.

Application Information

The AP74700Q is used with N-channel MOSFET in a typical reverse polarity protection application. The schematic for a 12V battery protection application is shown below where the AP74700Q is used in series with a battery to drive the MOSFET Q1. The TVS is not required for the AP74700Q to operate, but it is used to clamp the positive and negative voltage surges. The output capacitor COUT is recommended to protect the immediate output voltage from collapse as a result of line disturbance.

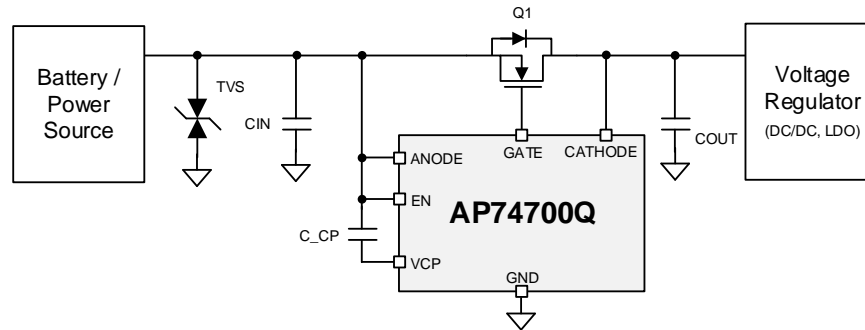

Design Example

Design Parameter	Example Value
VIN Range	12V car battery, 12V nominal with 3.2V cold crank and 35V load dump
VOUT	3.2V during cold crank to 35V load dump
IOUT	3A nominal and 5A maximum
COUT	1 μ F min, 47 μ F typical hold-up capacitor
Automotive EMC Compliance	ISO 7637-2 and ISO 16750-2

MOSFET Selection

The important MOSFET electrical parameters are the maximum continuous drain current I_D , the maximum drain to source voltage $V_{DS(MAX)}$, the maximum source current through body diode and the drain-to-source on-resistance $R_{DS(ON)}$.

The maximum continuous drain current, I_D , rating must exceed the maximum continuous load current. The maximum drain-to-source voltage, $V_{DS(MAX)}$, must be high enough to withstand the highest differential voltage seen in the application. This would include any anticipated fault conditions. It is recommended to use MOSFETs with voltage rating up to 60V maximum with the AP74700Q because anode-cathode maximum voltage is 65V. The maximum V_{GS} AP74700Q can drive is 13V, so a MOSFET with 15V minimum V_{GS} should be selected.

If a MOSFET with $< 15V$ V_{GS} rating is selected, a Zener diode can be used to clamp V_{GS} to safe level. During startup, inrush current flows through the body diode to charge the bulk hold-up capacitors at the output. The maximum source current through the body diode must be higher than the inrush current that can be seen in the application.

To reduce the MOSFET conduction losses, lowest possible $R_{DS(ON)}$ is preferred, but selecting a MOSFET based on low $R_{DS(ON)}$ may not be beneficial always. Higher $R_{DS(ON)}$ will provide increased voltage information to AP74700Q's reverse comparator at a lower reverse current. Reverse current detection is better with increased $R_{DS(ON)}$. It is recommended to operate the MOSFET in regulated conduction mode during nominal load conditions and select $R_{DS(ON)}$ such that at nominal operating current, forward voltage drop V_{DS} is close to 20mV regulation point and not more than 50mV.

As a guideline, it is suggested to choose $(20mV/I_{Load(Nominal)}) \leq R_{DS(ON)} \leq (50mV/I_{Load(Nominal)})$. MOSFET datasheets usually specify $R_{DS(ON)}$ at 4.5V V_{GS} and 10V V_{GS} . $R_{DS(ON)}$ increases drastically below 4.5V V_{GS} and $R_{DS(ON)}$ is highest when V_{GS} is close to MOSFET V_{TH} . For stable regulation at light load conditions, it is recommended to operate the MOSFET close to 4.5V V_{GS} , that is, much higher than MOSFET gate threshold voltage. It is recommended to choose MOSFET gate threshold voltage V_{TH} of 2V to 2.5V maximum. Choosing a lower V_{TH} MOSFET also reduces the turn ON time. Based on the design requirements, preferred MOSFET ratings are:

- 60V $V_{DS(MAX)}$ and $\pm 20V$ $V_{GS(MAX)}$
- $R_{DS(ON)}$ at 3A nominal current: $(20mV/3A) \leq R_{DS(ON)} \leq (50mV/3A) = 6.67m\Omega \leq R_{DS(ON)} \leq 16.67m\Omega$.
- MOSFET gate threshold voltage V_{TH} : 2V maximum

Application Information (continued)

DIODES™ DMT6007LFGQ MOSFET is selected to meet this 12V reverse battery protection design requirements and it is rated at:

- 60V $V_{DS(MAX)}$ and $\pm 20V$ $V_{GS(MAX)}$
- $R_{DS(ON)}$ 6.5m Ω typical and 8.5m Ω maximum rated at 4.5V V_{GS}
- MOSFET V_{TH} : 2V maximum

Thermal resistance of the MOSFET should be considered against the expected maximum power dissipation in the MOSFET to ensure that the junction temperature (T_J) is well controlled.

Charge Pump C_CP and CIN/COUT

Minimum required capacitance for charge pump VCP and input/output capacitance are:

- C_CP: Minimum 0.1 μ F is required; recommended value of VCP (μ F) $\geq 10 \times C_{ISS}$ (MOSFET) (μ F)
- CIN: Minimum 22nF of input capacitance
- COUT: Minimum 1 μ F of output capacitance.

TVS Selection for 12V Battery Protection Application

TVS diodes are used in automotive systems for protection against transients. In the 12V battery protection application circuit shown below, a bidirectional TVS diode is used to protect the system from positive and negative transient voltages that occur during normal operation of the car and these transient voltage levels and pulses are specified in ISO 7637-2 and ISO 16750-2 standards.

There are two important specifications, breakdown voltage and clamping voltage of the TVS. Breakdown voltage is the voltage at which the TVS diode goes into avalanche similar to a Zener diode and is specified at a low current value typical 1mA, and the breakdown voltage should be higher than worst case steady state voltages seen in the system. The breakdown voltage of the TVS+ should be higher than 24V jump start voltage and 35V suppressed load dump voltage and less than the maximum ratings of AP74700Q (65V). The breakdown voltage of TVS- should be beyond maximum reverse battery voltage -16V, so that the TVS- is not damaged due to long time exposure to reverse connected battery.

Clamping voltage is the voltage the TVS diode clamps in high current pulse situations and this voltage is much higher than the breakdown voltage. TVS diodes are meant to clamp transient pulses and should not interfere with steady state operation. In the case of ISO 7637-2 Pulse 1, the input voltage goes up to -150V with a generator impedance of 10 Ω . This translates to 15A flowing through the TVS- and the voltage across the TVS would be close to its clamping voltage.

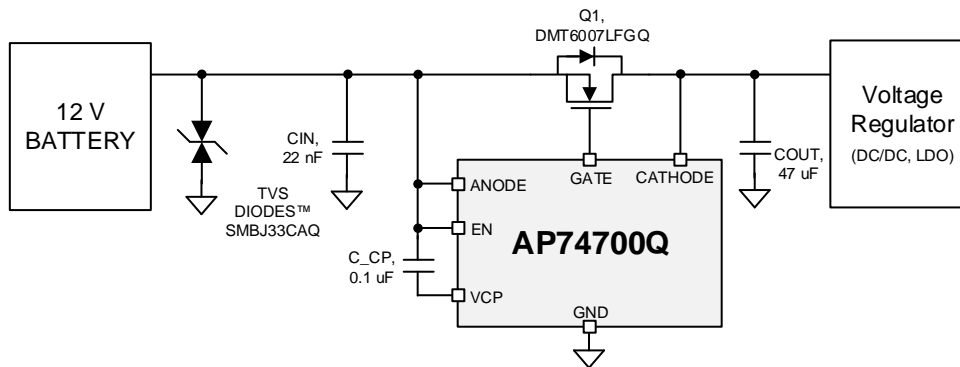

The next criterion is that the absolute maximum rating of ANODE to CATHODE reverse voltage of the AP74700Q (-75V) and the maximum V_{BS} rating MOSFET are not exceeded. In the design example, 60V rated MOSFET is chosen and maximum limit on the CATHODE to ANODE voltage is 60V. In case of ISO 7637-2 Pulse 1, the ANODE of AP74700Q is pulled down by the ISO pulse and clamped by TVS-. The MOSFET is turned off quickly to prevent reverse current from discharging the bulk output capacitors. When the MOSFET turns off, the CATHODE to ANODE voltage seen is equal to (TVS clamping voltage + output capacitor voltage). If the maximum voltage on output capacitor is 16V (maximum battery voltage), then the clamping voltage of the TVS- should not exceed, $(60V - 16V) = -44V$.

The SMBJ33CAQ TVS diode can be used for 12V battery protection application. The breakdown voltage of 36.7V meets the jump start, load dump requirements on the positive side and 16V reverse battery connection on the negative side. During ISO 7637-2 Pulse 1 test, the SMBJ33CAQ clamps at -44V with 15A of peak surge current as shown below and it meets the clamping voltage $\leq 44V$. SMBJ series of TVS' are rated up to 600W peak pulse power levels. This is sufficient for ISO 7637-2 Pulses and suppressed load dump (ISO-16750-2 Pulse B).

Application Information (continued)

TVS Selection for 24V Battery Protection Application

Typical 24V battery protection application circuit shown below uses two unidirectional TVS diodes to protect the system from positive and negative transient voltages.

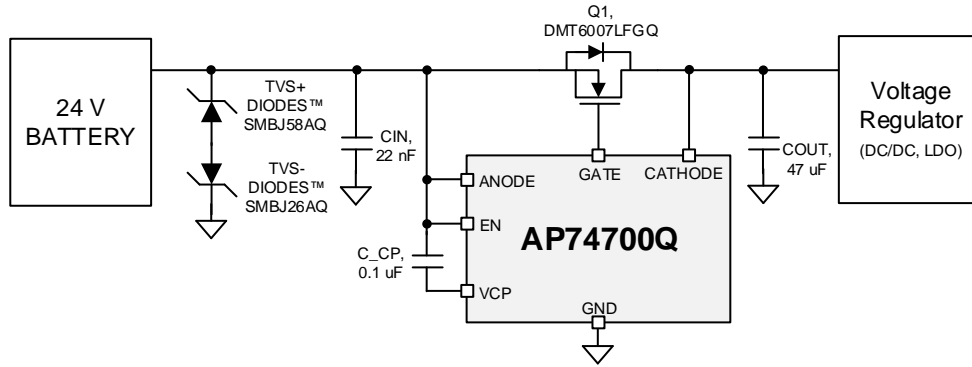

The breakdown voltage of the TVS+ should be higher than 48V jump start voltage, lower than the absolute maximum ratings of ANODE and EN pins of AP74700Q (65V) and should withstand 65V suppressed load dump. The breakdown voltage of TVS- should be lower than maximum reverse battery voltage -32V, so that the TVS- is not damaged due to long time exposure to reverse connected battery.

During ISO 7637-2 Pulse 1, the input voltage goes up to -600V with a generator impedance of 50Ω. This translates to 12A flowing through the TVS-. The clamping voltage of the TVS- cannot be same as that of 12V battery protection circuit. Because during the ISO 7637-2 Pulse, the ANODE to CATHODE voltage seen is equal to (-TVS clamping voltage + output capacitor voltage). For 24V battery application, the maximum battery voltage is 32V, then the clamping voltage of the TVS- should not exceed, $75V - 32V = 43V$.

Single bidirectional TVS cannot be used for 24V battery protection because breakdown voltage for TVS+ $\geq 65V$, maximum clamping voltage is $\leq 43V$ and the clamping voltage cannot be lower than the breakdown voltage. Two unidirectional TVS connected back-back needs to be used at the input. For positive side TVS+, SMBJ58AQ with the breakdown voltage of 64.4V (minimum), 67.8V (typical) is recommended. For the negative side TVS-, SMBJ26AQ with breakdown voltage close to 32V (to withstand maximum reverse battery voltage -32V) and maximum clamping voltage of 42.1V is recommended. For 24V battery protection, a 75V rated MOSFET is recommended to be used along with SMBJ26AQ and SMBJ58AQ connected back-back at the input.

Application Curves

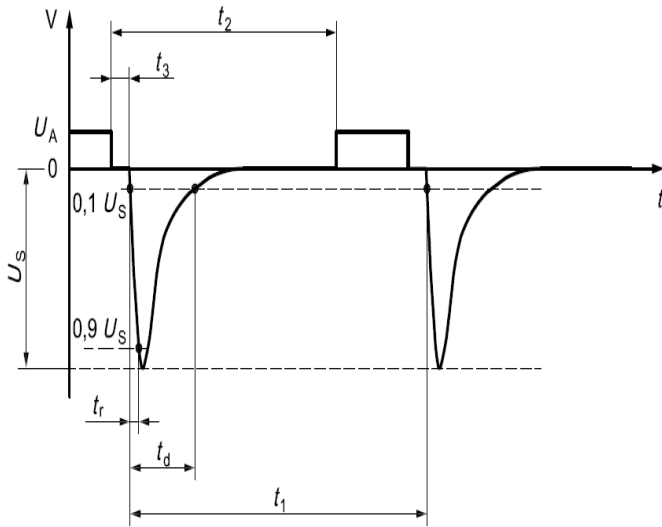

ISO 7637-2 Pulse 1

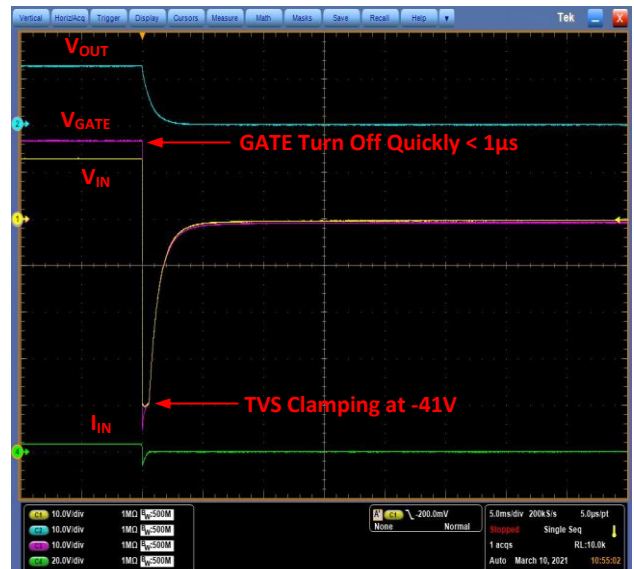

Response to ISO 7637-2 Pulse 1

Application Information (continued)

Start-up with 3A Load

CH1 = V_{IN} , CH2 = V_{OUT} , CH3 = V_{GATE} , CH4 = I_{IN}

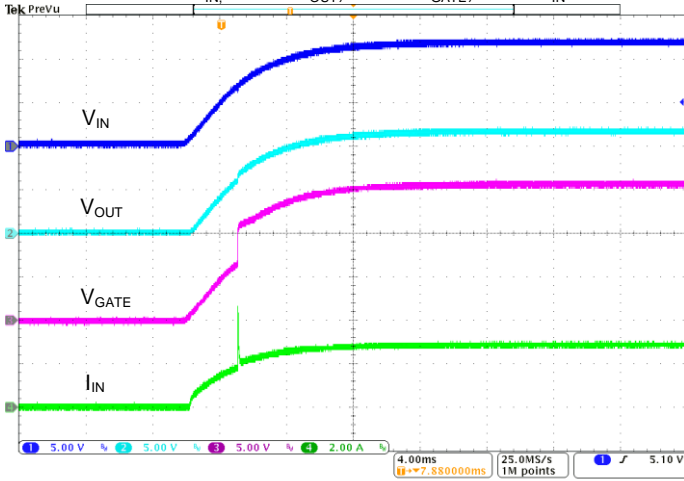

Start-up with 6A Load

CH1 = V_{IN} , CH2 = V_{OUT} , CH3 = V_{GATE} , CH4 = I_{IN}

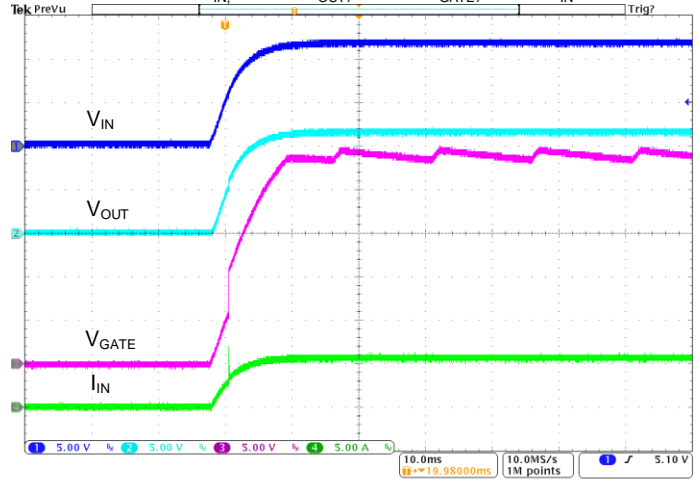

VCP During Start-up with 3A Load

CH1 = V_{IN} , CH2 = V_{CP} , CH3 = V_{GATE} , CH4 = I_{IN}

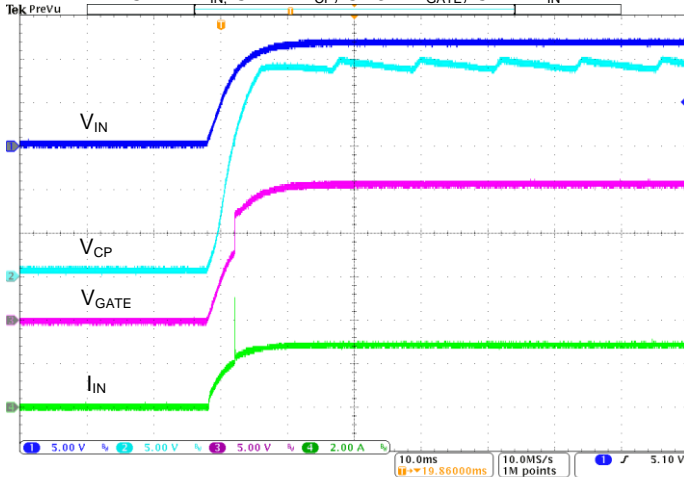

VCP During Start-up with 5.8A Load

CH1 = V_{IN} , CH2 = V_{CP} , CH3 = V_{GATE} , CH4 = I_{IN}

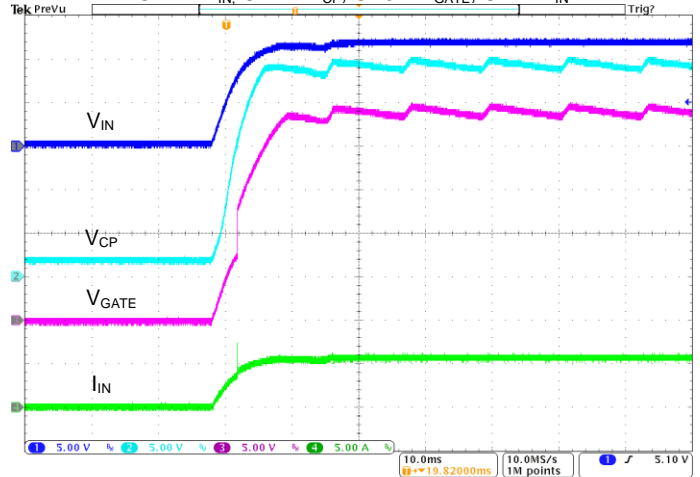

ORing V_{IN1} to V_{IN2} Switch Over

CH1 = V_{IN1} , CH2 = V_{OUT} , CH3 = V_{GATE1} , CH4 = I_{IN1}

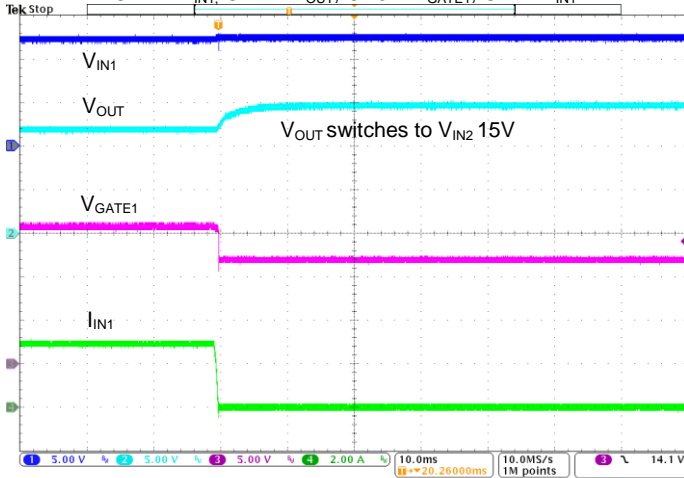

ORing V_{IN1} to V_{IN2} Switch Over

CH1 = V_{IN1} , CH2 = V_{OUT} , CH3 = V_{GATE1} , CH4 = I_{IN2}

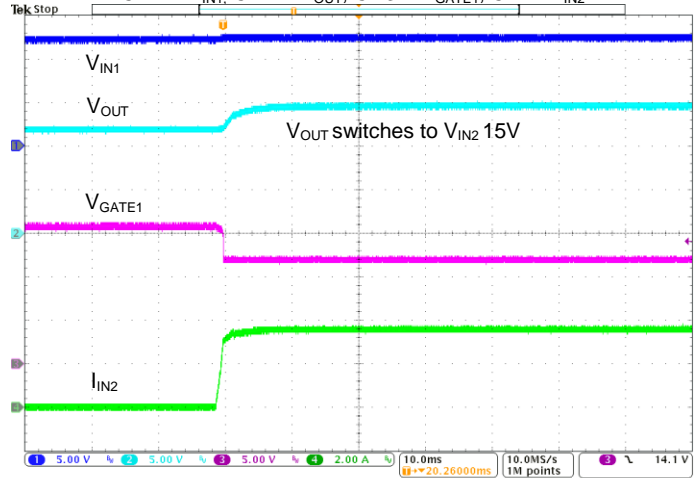

Application Information (continued)

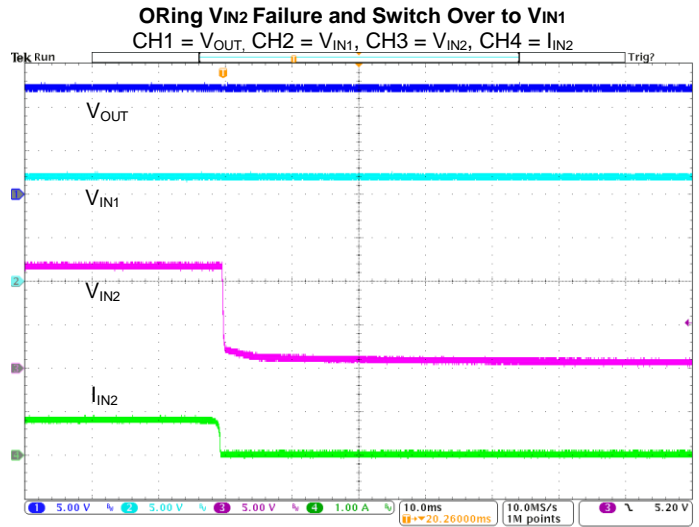
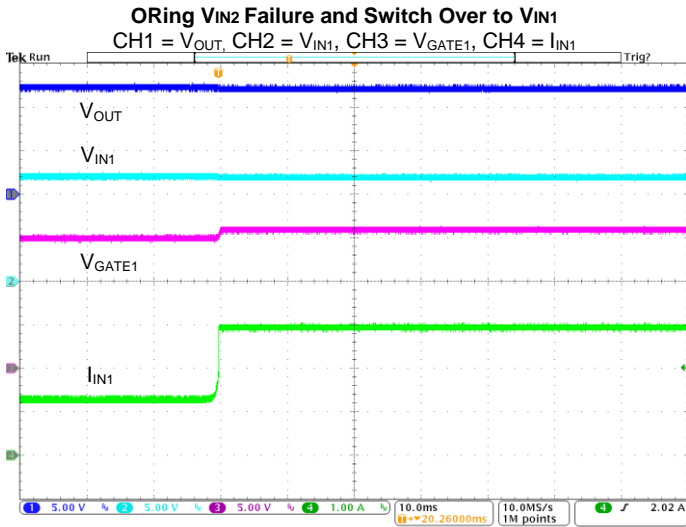
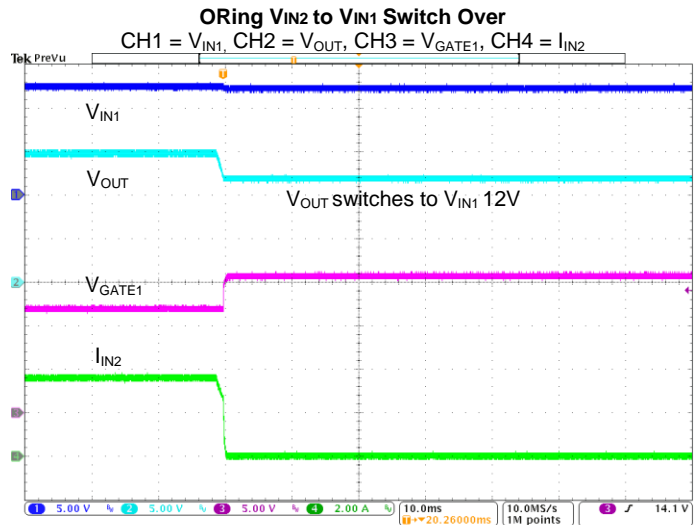
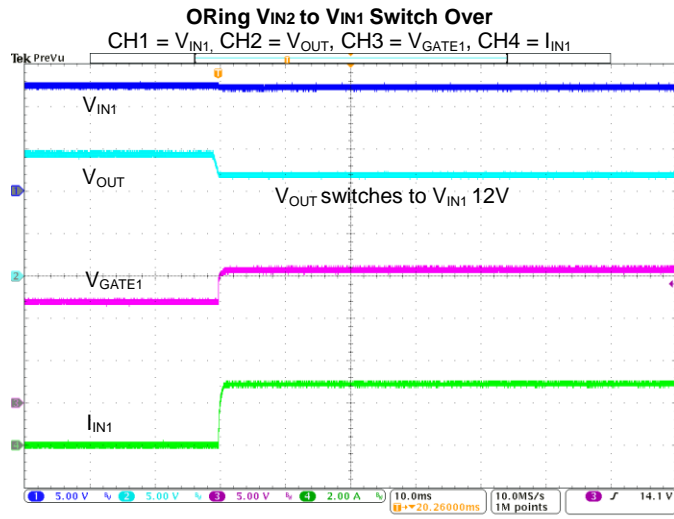

ORing Application Implementation

Basic redundant power architecture comprises of two or more voltage or power supply sources driving a single load. In its simplest form, the ORing solution for redundant power supplies consists of Schottky ORing diodes that protect the system against an input power supply fault condition. A diode ORing device provides effective and low cost solution with few components. However, the diodes forward voltage drops affect the efficiency of the system permanently, since each diode in an ORing application spends most of its time in forward conduction mode. These power losses increase the requirements for thermal management and allocated board space.

The AP74700Q ICs combined with external N-channel MOSFETs can be used in ORing solution. The forward diode drop is reduced as the external N-channel MOSFET is turned ON during normal operation. AP74700Q quickly detects the reverse current, pulls down the MOSFET gate fast, leaving the body diode of the MOSFET to block the reverse current flow. An effective ORing solution needs to be extremely fast to limit the reverse current amount and duration. The AP74700Q devices in ORing configuration constantly sense the voltage difference between ANODE and CATHODE pins, which are the voltage levels at the power sources (VIN1, VIN2) and the common load point respectively. The source to drain voltage V_{DS} for each MOSFET is monitored by the ANODE and CATHODE pins of the AP74700Q. A fast comparator shuts down the Gate Driver through a fast pull-down within 0.45μs (typical) as soon as V(IN) – V(OUT) falls below -10mV. It turns on the Gate Driver with 10mA gate charge current once the differential forward voltage V(IN) – V(OUT) exceeds 50mV.

Application Information (continued)

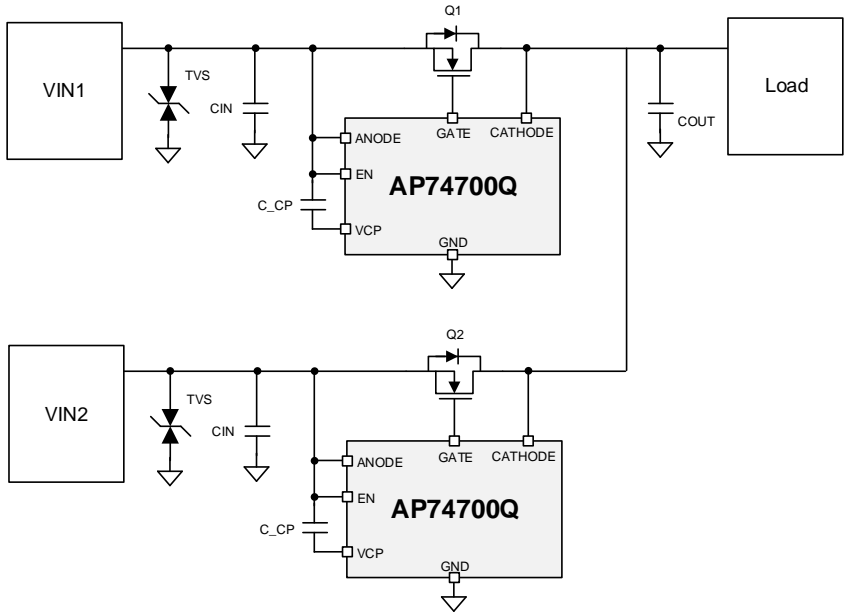

Ordering Information

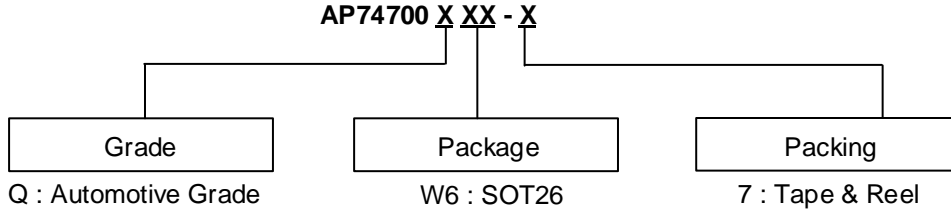

Part Number	Part Number Suffix	Enable Active	Package Code	Package	Packing	
					Qty.	Carrier
AP74700QW6-7	-7	High	W6	SOT26	3000	7" Tape and Reel

Marking Information

SOT26

(Top View)

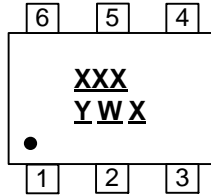

XXX : Identification Code
Y : Year 0 to 9 (ex: 2 = 2022)
W : Week : A to Z : week 1 to 26;
 a to y : week 27 to 51;
 z : week 52 and 53
X : Internal Code

Part Number	Package	Identification Code
AP74700QW6-7	SOT26	T8Q

Package Outline Dimensions

Please see <http://www.diodes.com/package-outlines.html> for the latest version.

SOT26

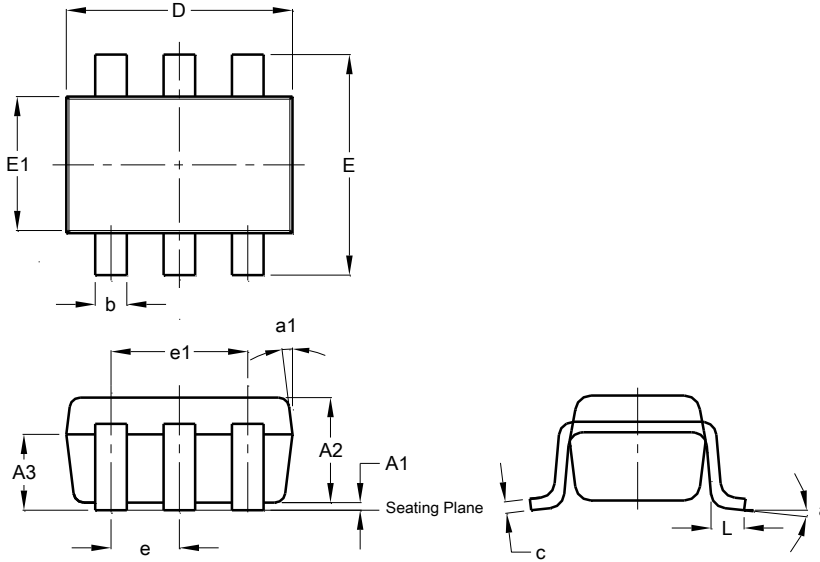

SOT26			
Dim	Min	Max	Typ
A1	0.013	0.10	0.05
A2	1.00	1.30	1.10
A3	0.70	0.80	0.75
b	0.35	0.50	0.38
c	0.10	0.20	0.15
D	2.90	3.10	3.00
e	-	-	0.95
e1	-	-	1.90
E	2.70	3.00	2.80
E1	1.50	1.70	1.60
L	0.35	0.55	0.40
a	-	-	8°
a1	-	-	7°
All Dimensions in mm			

Suggested Pad Layout

Please see <http://www.diodes.com/package-outlines.html> for the latest version.

SOT26

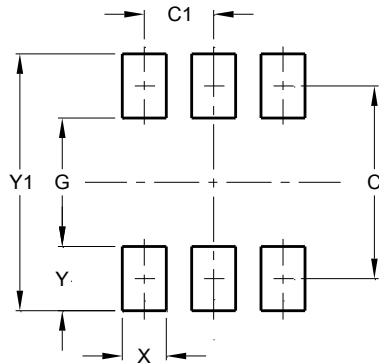

Dimensions	Value (in mm)
C	2.40
C1	0.95
G	1.60
X	0.55
Y	0.80
Y1	3.20



- Notes:
- The suggested land pattern dimensions have been provided for reference only, as actual pad layouts may vary depending on application. These dimensions may be modified based on user equipment capability or fabrication criteria. A more robust pattern may be desired for wave soldering and is calculated by adding 0.2mm to the 'Z' dimension. For further information, please reference document IPC-7351A, Naming Convention for Standard SMT Land Patterns, and for International grid details, please see document IEC, Publication 97.
 - For high voltage applications, the appropriate industry sector guidelines should be considered with regards to creepage and clearance distances between device terminals and PCB tracking.

Mechanical Data

- Surface Mount Package
- Moisture Sensitivity: Level 1 per J-STD-020
- Package Material: Molded Plastic, UL Flammability Classification Rating 94V-0
- Terminals: Finish – Matte Tin Plated Leads, Solderable per MIL-STD-202, Method 208 (E3)
- Weight: 0.016 grams (Approximate)
- Max Soldering Temperature +260°C for 30 secs as per JEDEC J-STD-020

Device Taping Orientation

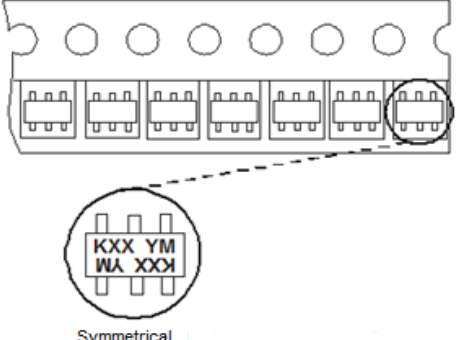
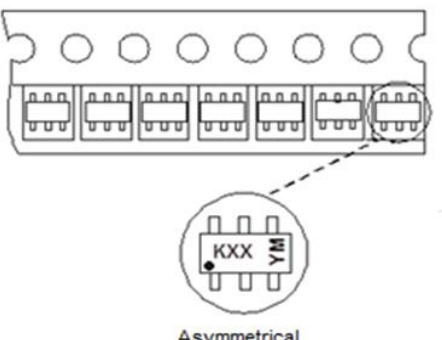
Package Type: SOT26

Tape Width	Part Number Suffix	Tape Orientation	
8mm	-7 -13 TA TC	 <p>The diagram shows a carrier tape with six SOT26 diodes. A dashed line points from the rightmost diode to a circular inset showing its top view. The top view is a rectangle with four pins (two on each long side) and the markings 'KXX YM' on the top edge and 'WA XXX' on the bottom edge. Below the inset is the label 'Symmetrical'.</p>	 <p>The diagram shows a carrier tape with six SOT26 diodes. A dashed line points from the rightmost diode to a circular inset showing its top view. The top view is a rectangle with four pins (two on each long side) and the markings 'KXX' on the left edge and 'YM' on the right edge. Below the inset is the label 'Asymmetrical'.</p>
		<p>Direction of feed </p>	

- Notes:
- 12. For part marking, refer to product datasheet.
 - 13. Tape and package drawings are not to scale and are shown for device tape orientation only.
 - 14. The taping orientation of the other package type can be found on our website at <https://www.diodes.com/assets/Packaging-Support-Docs/ap02007.pdf>.

IMPORTANT NOTICE

1. DIODES INCORPORATED (Diodes) AND ITS SUBSIDIARIES MAKE NO WARRANTY OF ANY KIND, EXPRESS OR IMPLIED, WITH REGARDS TO ANY INFORMATION CONTAINED IN THIS DOCUMENT, INCLUDING, BUT NOT LIMITED TO, THE IMPLIED WARRANTIES OF MERCHANTABILITY, FITNESS FOR A PARTICULAR PURPOSE OR NON-INFRINGEMENT OF THIRD PARTY INTELLECTUAL PROPERTY RIGHTS (AND THEIR EQUIVALENTS UNDER THE LAWS OF ANY JURISDICTION).
2. The Information contained herein is for informational purpose only and is provided only to illustrate the operation of Diodes' products described herein and application examples. Diodes does not assume any liability arising out of the application or use of this document or any product described herein. This document is intended for skilled and technically trained engineering customers and users who design with Diodes' products. Diodes' products may be used to facilitate safety-related applications; however, in all instances customers and users are responsible for (a) selecting the appropriate Diodes products for their applications, (b) evaluating the suitability of Diodes' products for their intended applications, (c) ensuring their applications, which incorporate Diodes' products, comply the applicable legal and regulatory requirements as well as safety and functional-safety related standards, and (d) ensuring they design with appropriate safeguards (including testing, validation, quality control techniques, redundancy, malfunction prevention, and appropriate treatment for aging degradation) to minimize the risks associated with their applications.
3. Diodes assumes no liability for any application-related information, support, assistance or feedback that may be provided by Diodes from time to time. Any customer or user of this document or products described herein will assume all risks and liabilities associated with such use, and will hold Diodes and all companies whose products are represented herein or on Diodes' websites, harmless against all damages and liabilities.
4. Products described herein may be covered by one or more United States, international or foreign patents and pending patent applications. Product names and markings noted herein may also be covered by one or more United States, international or foreign trademarks and trademark applications. Diodes does not convey any license under any of its intellectual property rights or the rights of any third parties (including third parties whose products and services may be described in this document or on Diodes' website) under this document.
5. Diodes' products are provided subject to Diodes' Standard Terms and Conditions of Sale (<https://www.diodes.com/about/company/terms-and-conditions/terms-and-conditions-of-sales/>) or other applicable terms. This document does not alter or expand the applicable warranties provided by Diodes. Diodes does not warrant or accept any liability whatsoever in respect of any products purchased through unauthorized sales channel.
6. Diodes' products and technology may not be used for or incorporated into any products or systems whose manufacture, use or sale is prohibited under any applicable laws and regulations. Should customers or users use Diodes' products in contravention of any applicable laws or regulations, or for any unintended or unauthorized application, customers and users will (a) be solely responsible for any damages, losses or penalties arising in connection therewith or as a result thereof, and (b) indemnify and hold Diodes and its representatives and agents harmless against any and all claims, damages, expenses, and attorney fees arising out of, directly or indirectly, any claim relating to any noncompliance with the applicable laws and regulations, as well as any unintended or unauthorized application.
7. While efforts have been made to ensure the information contained in this document is accurate, complete and current, it may contain technical inaccuracies, omissions and typographical errors. Diodes does not warrant that information contained in this document is error-free and Diodes is under no obligation to update or otherwise correct this information. Notwithstanding the foregoing, Diodes reserves the right to make modifications, enhancements, improvements, corrections or other changes without further notice to this document and any product described herein. This document is written in English but may be translated into multiple languages for reference. Only the English version of this document is the final and determinative format released by Diodes.
8. Any unauthorized copying, modification, distribution, transmission, display or other use of this document (or any portion hereof) is prohibited. Diodes assumes no responsibility for any losses incurred by the customers or users or any third parties arising from any such unauthorized use.
9. This Notice may be periodically updated with the most recent version available at <https://www.diodes.com/about/company/terms-and-conditions/important-notice>

DIODES is a trademark of Diodes Incorporated in the United States and other countries.
The Diodes logo is a registered trademark of Diodes Incorporated in the United States and other countries.
© 2022 Diodes Incorporated. All Rights Reserved.

www.diodes.com

Looking for pricing, stock, or lifecycle information?

Click below to explore more details on WIN SOURCE:

 [View AP74700QW6-7 on WIN SOURCE](#)

 [Diodes Incorporated](#) Information

Optimize Your Supply Chain with WIN SOURCE Solutions

-  Global Sourcing Solution
-  Obsolete Management
-  Cost Control Management
-  Shortage Management
-  Alternative Solution
-  Excess Inventory Management