



**THE DATASHEET OF
UCC21710DW**



UCC21710 10-A Source/Sink Reinforced Isolated Single Channel Gate Driver for SiC/IGBT with Active Protection, Isolated Analog Sensing and High-CMTI

1 Features

- 5.7-kV_{RMS} single channel isolated gate driver
- Drives SiC MOSFETs and IGBTs up to 2121V_{pk}
- 33-V maximum output drive voltage (VDD-VEE)
- ±10-A drive strength and split output
- 150-V/ns minimum CMTI
- 4-A internal active Miller clamp
- 400-mA soft turn-off under fault condition
- Isolated analog sensor with PWM output for
 - Temperature sensing with NTC, PTC or thermal diode
 - High voltage DC-Link or phase voltage
- Alarm $\overline{\text{FLT}}$ on over current and reset from $\overline{\text{RST/EN}}$
- Fast enable/disable response on $\overline{\text{RST/EN}}$
- Rejects <40-ns noise transient and pulses on input pins
- 12-V VDD UVLO with power good on RDY
- Inputs/outputs with over/under-shoot transient voltage immunity up to 5 V
- 130-ns (maximum) propagation delay and 30-ns (maximum) pulse/part skew
- SOIC-16 DW package with creepage and clearance distance > 8 mm
- Operating junction temperature –40°C to 150°C
- Safety-related certifications:
 - Reinforced insulation per DIN EN IEC 60747-17(VDE 0884-17)
 - UL 1577 component recognition program

2 Applications

- Industrial motor drives
- Server, telecom, and industrial power supplies
- Uninterruptible power supplies (UPS)
- Solar inverters
- Renewable energy storage converters

3 Description

The UCC21710 is a galvanically isolated single channel gate driver designed to drive up to 1700V SiC MOSFETs and IGBTs. It features advanced integrated protection, best-in-class dynamic performance, and robustness. UCC21710 has up to ±10-A peak source and sink current.

The input side is isolated from the output side with SiO₂ capacitive isolation technology, supporting up to 1.5-kV_{RMS} working voltage with longer than 40 years isolation barrier life, 12.8-kV_{PK} surge immunity, as well as providing low part-to-part skew, and >150V/ns common mode noise immunity (CMTI).

The UCC21710 includes the state-of-art protection features, such as fast overcurrent and short circuit detection, shunt current sensing support, fault reporting, active Miller clamp, and input and output side power supply UVLO to optimize SiC and IGBT switching behavior and robustness. The isolated analog to PWM sensor can be utilized for easier temperature or voltage sensing, further increasing the drivers' versatility and simplifying the system design effort, size and cost.

Device Information

PART NUMBER	PACKAGE ⁽¹⁾	BODY SIZE (NOM)
UCC21710	DW SOIC-16	10.3 mm × 7.5 mm

(1) For all available packages, see the orderable addendum at the end of the data sheet.

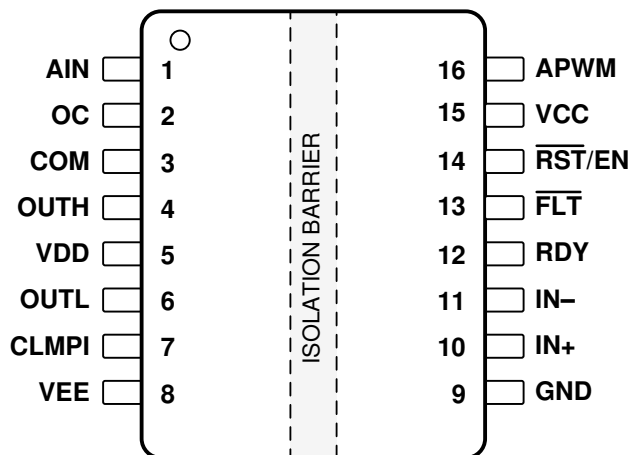

Not to scale

Device Pin Configuration



Table of Contents

1 Features	1	7.5 OC (Over Current) Protection.....	21
2 Applications	1	8 Detailed Description	22
3 Description	1	8.1 Overview.....	22
4 Revision History	2	8.2 Functional Block Diagram.....	23
5 Pin Configuration and Functions	3	8.3 Feature Description.....	23
6 Specifications	4	8.4 Device Functional Modes.....	29
6.1 Absolute Maximum Ratings.....	4	9 Applications and Implementation	30
6.2 ESD Ratings.....	4	9.1 Application Information.....	30
6.3 Recommended Operating Conditions.....	4	9.2 Typical Application.....	31
6.4 Thermal Information.....	5	10 Power Supply Recommendations	44
6.5 Power Ratings.....	5	11 Layout	45
6.6 Insulation Specifications.....	6	11.1 Layout Guidelines.....	45
6.7 Safety-Related Certifications.....	7	11.2 Layout Example.....	46
6.8 Safety Limiting Values.....	7	12 Device and Documentation Support	47
6.9 Electrical Characteristics.....	8	12.1 Device Support.....	47
6.10 Switching Characteristics.....	10	12.2 Documentation Support.....	47
6.11 Insulation Characteristics Curves.....	11	12.3 Receiving Notification of Documentation Updates.....	47
6.12 Typical Characteristics.....	12	12.4 Support Resources.....	47
7 Parameter Measurement Information	16	12.5 Trademarks.....	47
7.1 Propagation Delay.....	16	12.6 Electrostatic Discharge Caution.....	47
7.2 Input Deglitch Filter.....	17	12.7 Glossary.....	47
7.3 Active Miller Clamp.....	18	13 Mechanical, Packaging, and Orderable Information	47
7.4 Under Voltage Lockout (UVLO).....	19		

4 Revision History

NOTE: Page numbers for previous revisions may differ from page numbers in the current version.

Changes from Revision A (November 2020) to Revision B (May 2023)	Page
• Added Safety-related certifications to Features.....	1
• Added what to do with unused pins to pin functions table.....	3
• Changed recommended value of decoupling capacitors.....	3
• Added recommended decoupling capacitor layout placement.....	3
• Changed test conditions per DIN EN IEC 60747-17 (VDE 0884-17).....	6
• Changed certification status.....	7
• Changed V _{Ain} lower limit to 0.6V.....	8
• Changed direction of I _{CLMPI} in V _{CLP-CLMPI} test condition.....	8
• Added test condition for soft turn-off current.....	8
• Deleted short circuit clamping max condition.....	8
• Change OC figure.....	27
• Added function state showing gate driver turning on. Changed RDY condition when VCC is PD.....	29
• Changed OC figure.....	37
• Changed OC figure.....	38
• Changed OC figure.....	39
• Deleted tie dot in Figure 9-16	43

Changes from Revision * (August 2020) to Revision A (November 2020)	Page
• Changed marketing status from Advance Information to Production Data.....	1

5 Pin Configuration and Functions

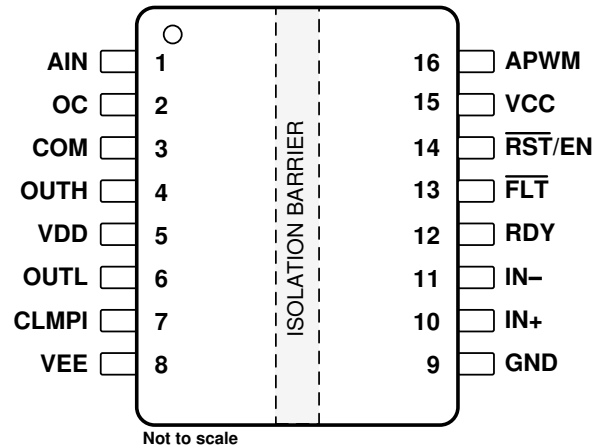

Figure 5-1. UCC21710 DW SOIC (16) Top View

Table 5-1. Pin Functions

PIN		I/O ⁽¹⁾	DESCRIPTION
NAME	NO.		
AIN	1	I	Isolated analog sensing input, parallel a small capacitor to COM for better noise immunity. Tie to COM if unused.
OC	2	I	Over current detection pin, support lower threshold for SenseFET, DESAT, and shunt resistor sensing. Tie to COM if unused.
COM	3	P	Common ground reference, connecting to emitter pin for IGBT or source pin for SiC-MOSFET
OUTH	4	O	Gate driver output pull up
VDD	5	P	Positive supply rail for gate drive voltage. Bypass with a >10- μ F capacitor to COM to support specified gate driver source peak current capability. Place decoupling capacitor close to the pin.
OUTL	6	O	Gate driver output pull down
CLMPI	7	O	Internal Active miller clamp, connecting this pin directly to the gate of the power transistor. Leave floating or tie to VEE if unused.
VEE	8	P	Negative supply rail for gate drive voltage. Bypass with a >10- μ F capacitor to COM to support specified gate driver sink peak current capability. Place decoupling capacitor close to the pin.
GND	9	P	Input power supply and logic ground reference
IN+	10	I	Non-inverting gate driver control input. Tie to VCC if unused.
IN-	11	I	Inverting gate driver control input. Tie to GND if unused.
RDY	12	O	Power good for VCC-GND and VDD-COM. RDY is open drain configuration and can be paralleled with other RDY signals
FLT	13	O	Active low fault alarm output upon over current or short circuit. FLT is in open drain configuration and can be paralleled with other faults
RST/EN	14	I	The RST/EN serves two purposes: 1) Enable / shutdown of the output side. The FET is turned off by a regular turn-off, if terminal EN is set to low; 2) Resets the OC condition signaled on FLT pin. if terminal RST/EN is set to low for more than 1000ns. A reset of signal FLT is asserted at the rising edge of terminal RST/EN. For automatic RESET function, this pin only serves as an EN pin. Enable / shutdown of the output side. The FET is turned off by a general turn-off, if terminal EN is set to low.
VCC	15	P	Input power supply from 3V to 5.5V. Bypass with a >1- μ F capacitor to GND. Place decoupling capacitor close to the pin.
APWM	16	O	Isolated Analog Sensing PWM output. Leave floating if unused.

(1) P = Power, G = Ground, I = Input, O = Output

6 Specifications

6.1 Absolute Maximum Ratings

over operating free-air temperature range (unless otherwise noted)⁽¹⁾

PARAMETER		MIN	MAX	UNIT
VCC	VCC – GND	–0.3	6	V
VDD	VDD – COM	–0.3	36	V
VEE	VEE – COM	–17.5	0.3	V
V _{MAX}	VDD – VEE	–0.3	36	V
IN+, IN–, $\overline{\text{RST}}/\text{EN}$	DC	GND–0.3	VCC	V
		Transient, less than 100 ns ⁽²⁾	VCC+5.0	V
A _{IN}	Reference to COM	–0.3	5	V
OC	Reference to COM	–0.3	6	V
OUTH, OUTL, CLMPI	DC	VEE–0.3	VDD	V
		Transient, less than 100 ns ⁽²⁾	VDD+5.0	V
RDY, $\overline{\text{FLT}}$, APWM		GND–0.3	VCC	V
I _{FLT} , I _{RDY}	$\overline{\text{FLT}}$, and RDY pin input current		20	mA
I _{APWM}	APWM pin output current		20	mA
T _J	Junction temperature range	–40	150	°C
T _{stg}	Storage temperature range	–65	150	°C

(1) Stresses beyond those listed under *absolute maximum ratings* may cause permanent damage to the device. These are stress ratings only and functional operation of the device at these or any other conditions beyond those indicated under *recommended operating conditions* is not implied. Exposure to absolute-maximum-rated conditions for extended periods may affect device reliability.

(2) Values are verified by characterization on bench.

6.2 ESD Ratings

		VALUE	UNIT
V _(ESD)	Electrostatic discharge	Human-body model (HBM), per ANSI/ESDA/JEDEC JS-001 ⁽¹⁾	±4000
		Charged-device model (CDM), per JEDEC specification JESD22-C101 ⁽²⁾	±1500

(1) JEDEC document JEP155 states that 500-V HBM allows safe manufacturing with a standard ESD control process.

(2) JEDEC document JEP157 states 250-V CDM allows safe manufacturing with a standard ESD control process.

6.3 Recommended Operating Conditions

PARAMETER		MIN	MAX	UNIT
VCC	VCC–GND	3.0	5.5	V
VDD	VDD–COM	13	33	V
V _{MAX}	VDD–VEE	–	33	V
IN+, IN–, $\overline{\text{RST}}/\text{EN}$	Reference to GND	High level input voltage	0.7×VCC	VCC
		Low level input voltage	0	0.3×VCC
A _{IN}	Reference to COM	0.6	4.5	V
t _{RST/EN}	Minimum pulse width that reset the fault	1000		ns
T _A	Ambient Temperature	–40	125	°C
T _J	Junction temperature	–40	150	°C

6.4 Thermal Information

THERMAL METRIC ⁽¹⁾		UCC21710	UNIT
		DW (SOIC)	
		16-PINS	
R _{θJA}	Junction-to-ambient thermal resistance	68.3	°C/W
R _{θJC(top)}	Junction-to-case (top) thermal resistance	27.5	°C/W
R _{θJB}	Junction-to-board thermal resistance	32.9	°C/W
Ψ _{JT}	Junction-to-top characterization parameter	14.1	°C/W
Ψ _{JB}	Junction-to-board characterization parameter	32.3	°C/W

(1) For more information about traditional and new thermal metrics, see the [Semiconductor and IC Package Thermal Metrics](#) application report.

6.5 Power Ratings

PARAMETER		TEST CONDITIONS	Value	UNIT
P _D	Maximum power dissipation (both sides)	VCC = 5V, VDD-COM = 20V, COM-VEE = 5V, IN+/- = 5V, 150kHz, 50% Duty Cycle for 10nF load, T _a =25°C	985	mW
P _{D1}	Maximum power dissipation by transmitter side		20	mW
P _{D2}	Maximum power dissipation by receiver side		965	mW

6.6 Insulation Specifications

PARAMETER		TEST CONDITIONS	VALUE	UNIT
GENERAL				
CLR	External clearance ⁽¹⁾	Shortest terminal-to-terminal distance through air	> 8	mm
CPG	External creepage ⁽¹⁾	Shortest terminal-to-terminal distance across the package surface	> 8	mm
DTI	Distance through the insulation	Minimum internal gap (Internal clearance) of the double insulation (2 × 0.0085 mm)	> 17	µm
CTI	Comparative tracking index	DIN EN 60112 (VDE 0303-11); IEC 60112	> 600	V
	Material group	According to IEC 60664–1	I	
	Overtoltage Category per IEC 60664–1	Rated mains voltage ≤ 300 V _{RMS}	I-IV	
		Rated mains voltage ≤ 600 V _{RMS}	I-IV	
		Rated mains voltage ≤ 1000 V _{RMS}	I-III	
DIN EN IEC 60747-17 (VDE 0884-17)⁽²⁾				
V _{IORM}	Maximum repetitive peak isolation voltage	AC voltage (bipolar)	2121	V _{PK}
V _{IOWM}	Maximum isolation working voltage	AC voltage (sine wave) Time dependent dielectric breakdown (TDDB) test	1500	V _{RMS}
		DC voltage	2121	V _{DC}
V _{IMP}	Maximum impulse voltage	Tested in air, 1.2/50-µs waveform per IEC 62368-1	8000	V _{PK}
V _{IOTM}	Maximum transient isolation voltage	V _{TEST} =V _{IOTM} , t = 60 s (qualification test)	8000	V _{PK}
		V _{TEST} =1.2 × V _{IOTM} , t = 1 s (100% production test)		
V _{IOSM}	Maximum surge isolation voltage ⁽³⁾	Test method per IEC 62368-1, 1.2/50 µs waveform, V _{TEST} = 1.6 × V _{IOSM} = 12800 V _{PK} (qualification)	8000	V _{PK}
q _{pd}	Apparent charge ⁽⁴⁾	Method a: After I/O safety test subgroup 2/3, V _{ini} = V _{IOTM} , t _{ini} = 60 s; V _{pd(m)} = 1.2 × V _{IORM} = 2545 V _{PK} , t _m = 10 s	≤ 5	pC
		Method a: After environmental tests subgroup 1, V _{ini} = V _{IOTM} , t _{ini} = 60 s; V _{pd(m)} = 1.6 × V _{IORM} = 3394 V _{PK} , t _m = 10 s	≤ 5	
		Method b1: At routine test (100% production) and preconditioning (type test) V _{ini} = V _{IOTM} , t _{ini} = 1 s; V _{pd(m)} = 1.875 × V _{IORM} = 3977 V _{PK} , t _m = 1 s	≤ 5	
C _{IO}	Barrier capacitance, input to output ⁽⁵⁾	V _{IO} = 0.5 sin (2πft), f = 1 MHz	~ 1	pF
R _{IO}	Insulation resistance, input to output ⁽⁵⁾	V _{IO} = 500 V, T _A = 25°C	≥ 10 ¹²	Ω
		V _{IO} = 500 V, 100°C ≤ T _A ≤ 125°C	≥ 10 ¹¹	
		V _{IO} = 500 V at T _S = 150°C	≥ 10 ⁹	
	Pollution degree		2	
	Climatic category		40/125/21	
UL 1577				
V _{ISO}	Withstand isolation voltage	V _{TEST} = V _{ISO} = 5700 V _{RMS} , t = 60 s (qualification); V _{TEST} = 1.2 × V _{ISO} = 6840 V _{RMS} , t = 1 s (100% production)	5700	V _{RMS}

- (1) Apply creepage and clearance requirements according to the specific equipment isolation standards of an application. Care must be taken to maintain the creepage and clearance distance of a board design to ensure that the mounting pads of the isolator on the printed circuit board (PCB) do not reduce this distance. Creepage and clearance on a PCB become equal in certain cases. Techniques such as inserting grooves and ribs on the PCB are used to help increase these specifications.
- (2) This coupler is suitable for safe electrical insulation only within the safety ratings. Compliance with the safety ratings shall be ensured by means of suitable protective circuits.
- (3) Testing is carried out in air or oil to determine the intrinsic surge immunity of the isolation barrier.
- (4) Apparent charge is electrical discharge caused by a partial discharge (pd).
- (5) All pins on each side of the barrier tied together creating a two-terminal device

6.7 Safety-Related Certifications

VDE	UL
Certified according to DIN EN IEC 60747-17 (VDE 0884-17)	Recognized under UL 1577 Component Recognition Program, CSA Component Acceptance Notice 5A
Reinforced insulation Maximum transient isolation voltage, 8000 V _{PK} ; Maximum repetitive peak isolation voltage, 2121 V _{PK} ; Maximum surge isolation voltage, 8000 V _{PK}	Single protection, 5700 V _{RMS}
Certificate number: 40040142	File Number: E181974

6.8 Safety Limiting Values

Safety limiting ⁽¹⁾ intends to minimize potential damage to the isolation barrier upon failure of input or output circuitry. A failure of the I/O can allow low resistance to ground or the supply and, without current limiting, dissipate sufficient power to overheat the die and damage the isolation barrier, potentially leading to secondary system failures.

PARAMETER		TEST CONDITIONS	MIN	TYP	MAX	UNIT
I _S	Safety input, output, or supply current	R _{θJA} = 68.3°C/W, V _{DD} = 15V, V _{EE} = -5V, T _J = 150°C, T _A = 25°C			61	mA
		R _{θJA} = 68.3°C/W, V _{DD} = 20V, V _{EE} = -5V, T _J = 150°C, T _A = 25°C			49	
P _S	Safety input, output, or total power	R _{θJA} = 68.3°C/W, V _{DD} = 20V, V _{EE} = -5V, T _J = 150°C, T _A = 25°C			1220	mW
T _S	Safety temperature				150	°C

- (1) The safety-limiting constraint is the maximum junction temperature specified in the data sheet. The power dissipation and junction-to-air thermal impedance of the device installed in the application hardware determines the junction temperature. The assumed junction-to-air thermal resistance in the [Section 6.4](#) table is that of a device installed on a high-K test board for leaded surface-mount packages. The power is the recommended maximum input voltage times the current. The junction temperature is then the ambient temperature plus the power times the junction-to-air thermal resistance. These limits vary with the ambient temperature, the junction-to-air thermal resistance, and the power supply voltages in different applications.

6.9 Electrical Characteristics

VCC=3.3V or 5.0V, 1uF capacitor from VCC to GND, VDD-COM=20V, 18V or 15V, COM-VEE =0V, 5V, 8V or 15V, C_L=100pF, -40°C<T_J<150°C (unless otherwise noted)^{(1) (2)}.

PARAMETER		TEST CONDITIONS	MIN	TYP	MAX	UNIT
VCC UVLO THRESHOLD AND DELAY						
V _{VCC_ON}	VCC-GND		2.55	2.7	2.85	V
V _{VCC_OFF}			2.35	2.5	2.65	
V _{VCC_HYS}				0.2		
t _{VCCFIL}	VCC UVLO Deglitch time			10		μs
t _{VCC+ to OUT}	VCC UVLO on delay to output high	IN+ = VCC, IN- = GND	28	37.8	50	
t _{VCC- to OUT}	VCC UVLO off delay to output low		5	10	15	
t _{VCC+ to RDY}	VCC UVLO on delay to RDY high	RST/EN = VCC	30	37.8	50	
t _{VCC- to RDY}	VCC UVLO off delay to RDY low		5	10	15	
VDD UVLO THRESHOLD AND DELAY						
V _{VDD_ON}	VDD-COM		10.5	12.0	12.8	V
V _{VDD_OFF}			9.9	10.7	11.8	
V _{VDD_HYS}				0.8		
t _{VDDFIL}	VDD UVLO Deglitch time			5		μs
t _{VDD+ to OUT}	VDD UVLO on delay to output high	IN+ = VCC, IN- = GND	2	5	8	
t _{VDD- to OUT}	VDD UVLO off delay to output low		5		10	
t _{VDD+ to RDY}	VDD UVLO on delay to RDY high	RST/EN = FLT=High		10	15	
t _{VDD- to RDY}	VDD UVLO off delay to RDY low		10		15	
VCC, VDD QUIESCENT CURRENT						
I _{VCCQ}	VCC quiescent current	OUT(H) = High, f _S = 0Hz, AIN=2V	2.5	3	4	mA
		OUT(L) = Low, f _S = 0Hz, AIN=2V	1.45	2	2.75	
I _{VDDQ}	VDD quiescent current	OUT(H) = High, f _S = 0Hz, AIN=2V	3.6	4	5.9	mA
		OUT(L) = Low, f _S = 0Hz, AIN=2V	3.1	3.7	5.3	
LOGIC INPUTS — IN+, IN- and RST/EN						
V _{INH}	Input high threshold	V _{CC} =3.3V		1.85	2.31	V
V _{INL}	Input low threshold	V _{CC} =3.3V	0.99	1.52		V
V _{INHYS}	Input threshold hysteresis	V _{CC} =3.3V		0.33		V
I _{IH}	Input high level input leakage current	V _{IN} = VCC		90		μA
I _{IL}	Input low level input leakage	V _{IN} = GND		-90		μA
R _{IND}	Input pins pull down resistance	see Section 8 for more information		55		kΩ
R _{INU}	Input pins pull up resistance	see Section 8 for more information		55		
T _{INFIL}	IN+, IN- and RST/EN deglitch (ON and OFF) filter time	f _S = 50kHz	28	40	60	ns
T _{RSTFIL}	Deglitch filter time to reset /FLT		400	650	800	ns
GATE DRIVER STAGE						
I _{OUT} , I _{OUTH}	Peak source current	C _L =0.18μF, f _S =1kHz		10		A
I _{OUT} , I _{OUTL}	Peak sink current				10	
R _{OUTH} ⁽³⁾	Output pull-up resistance	I _{OUT} = -0.1A		2.5		Ω
R _{OUTL}	Output pull-down resistance	I _{OUT} = 0.1A		0.3		Ω
V _{OUTH}	High level output voltage	I _{OUT} = -0.2A, V _{DD} =18V		17.5		V

6.9 Electrical Characteristics (continued)

VCC=3.3V or 5.0V, 1uF capacitor from VCC to GND, VDD-COM=20V, 18V or 15V, COM-VEE =0V, 5V, 8V or 15V, C_L=100pF, -40°C<T_J<150°C (unless otherwise noted)⁽¹⁾ (2).

PARAMETER		TEST CONDITIONS	MIN	TYP	MAX	UNIT
V _{OUTL}	Low level output voltage	I _{OUT} = 0.2A		60		mV
ACTIVE PULLDOWN						
V _{OUTPD}	Output active pull down on OUT, OUTL	I _{OUTL} or I _{OUT} = 0.1×I _{OUT(L)(typ)} , VDD=OPEN, VEE=COM	1.5	2	2.5	V
INTERNAL ACTIVE MILLER CLAMP						
V _{CLMPH}	Miller clamp threshold voltage	Reference to VEE	1.5	2.0	2.5	V
V _{CLMPI}	Output low clamp voltage	I _{CLMPI} = 1A		VEE + 0.5		V
I _{CLMPI}	Output low clamp current	V _{CLMPI} = 0V, VEE = -2.5V		4		A
R _{CLMPI}	Miller clamp pull down resistance	I _{CLMPI} = 0.2A		0.6		Ω
t _{DCLMPI}	Miller clamp ON delay time	C _L = 1.8nF		15	50	ns
SHORT CIRCUIT CLAMPING						
V _{CLP-OUT(H)}	V _{OUT} -VDD, V _{OUTH} -VDD	OUT = Low, I _{OUT(H)} = 500mA, t _{CLP} =10us		0.9		V
V _{CLP-OUT(L)}	V _{OUT} -VDD, V _{OUTL} -VDD	OUT = High, I _{OUT(L)} = 500mA, t _{CLP} =10us		1.8		V
V _{CLP-CLMPI}	V _{CLMPI} -VDD	OUT = High, I _{CLMPI} = 20mA, t _{CLP} =10us		1.0		V
OC PROTECTION						
I _{DCHG}	OC pull down current when	V _{OC} = 1V		40		mA
V _{OCTH}	Detection Threshold		0.63	0.7	0.77	V
V _{OCL}	Voltage when OUT(L) = LOW, Reference to COM	I _{OC} = 5mA		0.13		V
t _{OCFIL}	OC fault deglitch filter		95	120	180	ns
t _{OCOFF}	OC propagation delay to OUT(L) 90%		150	270	400	ns
t _{OCFLT}	OC to FLT low delay		300	530	750	ns
INTERNAL SOFT TURN-OFF						
I _{STO}	Soft turn-off current on fault conditions	V _{DD} -V _{EE} =20V, V _{OUTL} -COM=8V	250	400	570	mA
ISOLATED TEMPERATURE SENSE AND MONITOR (AIN-APWM)						
V _{AIN}	Analog sensing voltage range		0.6		4.5	V
I _{AIN}	Internal current source	V _{AIN} =2.5V, -40°C< T _J < 150°C	196	203	209	μA
f _{APWM}	APWM output frequency	V _{AIN} =2.5V	380	400	420	kHz
BW _{AIN}	AIN-APWM bandwidth			10		kHz
D _{APWM}	APWM Duty cycle	V _{AIN} = 0.6V	86.5	88	89.5	%
		V _{AIN} = 2.5V	48.5	50	51.5	
		V _{AIN} = 4.5V	7.5	10	11.5	
FLT AND RDY REPORTING						
t _{RDYHLD}	VDD UVLO RDY low minimum holding time		0.55		1	ms
t _{FLTMUTE}	Output mute time on fault	Reset fault through RST/EN	0.55		1	ms
R _{ODON}	Open drain output on resistance	I _{ODON} = 5mA		30		Ω
V _{ODL}	Open drain low output voltage	I _{ODON} = 5mA			0.3	V
COMMON MODE TRANSIENT IMMUNITY						
CMTI	Common-mode transient immunity		150			V/ns

- (1) Current are positive into and negative out of the specified terminal.
- (2) All voltages are referenced to COM unless otherwise notified.
- (3) For internal PMOS only. Refer to [Section 8.3](#) for effective pull-up resistance.

6.10 Switching Characteristics

VCC=5.0V, 1uF capacitor from VCC to GND, VDD-COM=20V, 18V or 15V, COM-VEE = 3V, 5V or 8V, C_L=100pF, – 40°C<T_J<150°C (unless otherwise noted)

PARAMETER		TEST CONDITIONS	MIN	TYP	MAX	UNIT
t _{PDHL}	Propagation delay time – High to Low		60	90	130	ns
t _{PDLH}	Propagation delay time – Low to High		60	90	130	
PWD	Pulse width distortion t _{PDHL} – t _{PDLH}				30	
t _{sk-pp}	Part to Part skew	Rising or Falling Propagation Delay			30	
t _r	Driver output rise time	C _L =10nF		33		
t _f	Driver output fall time	C _L =10nF		27		
f _{MAX}	Maximum switching frequency				1	

6.11 Insulation Characteristics Curves

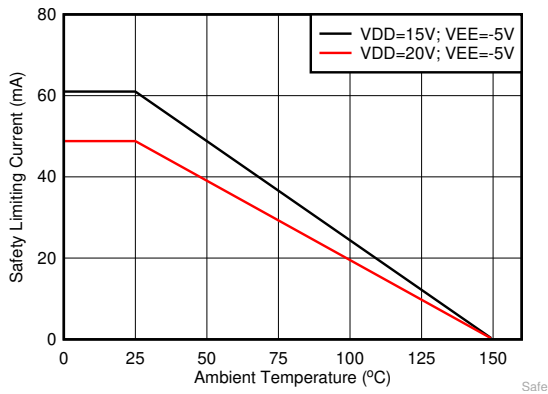

Figure 6-1. Thermal Derating Curve for Limiting Current per VDE

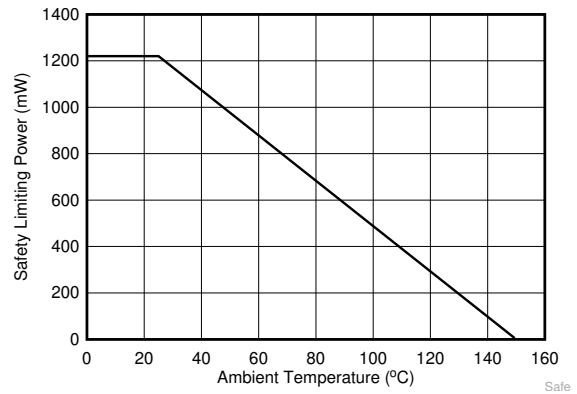

Figure 6-2. Thermal Derating Curve for Limiting Power per VDE

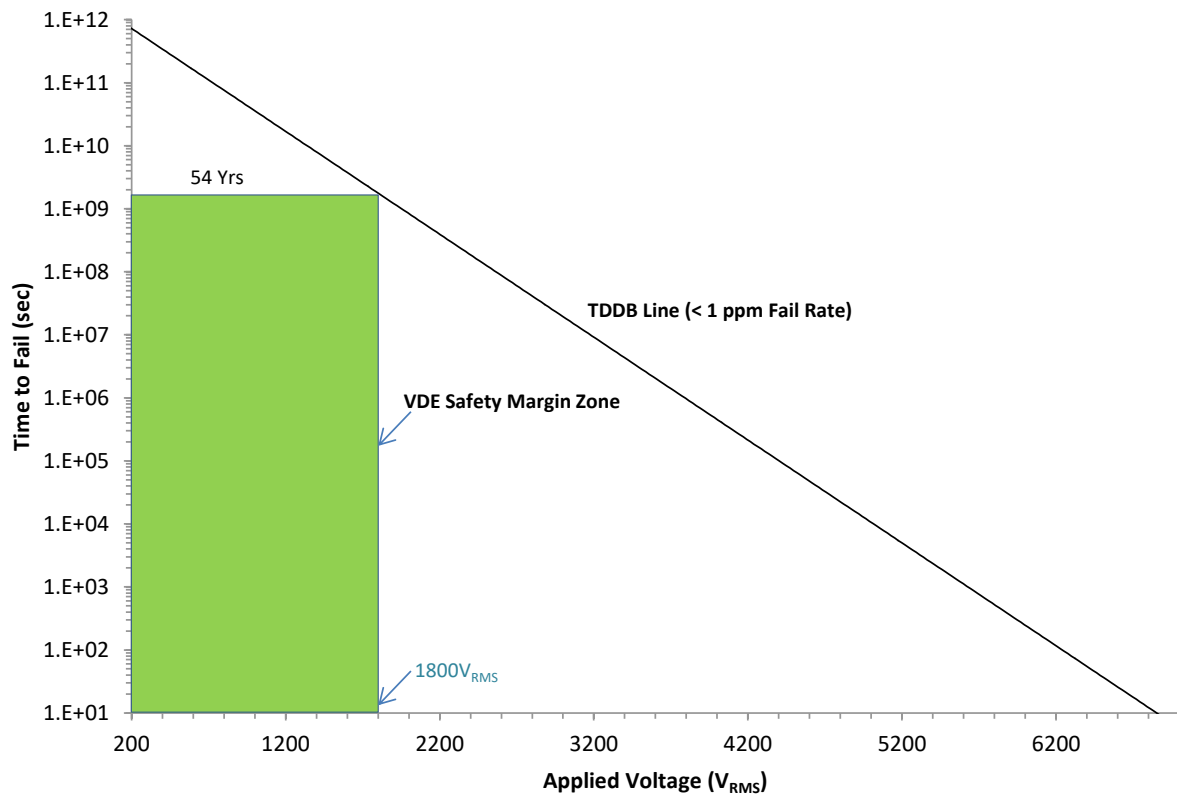

Figure 6-3. Reinforced Isolation Capacitor Life Time Projection

6.12 Typical Characteristics

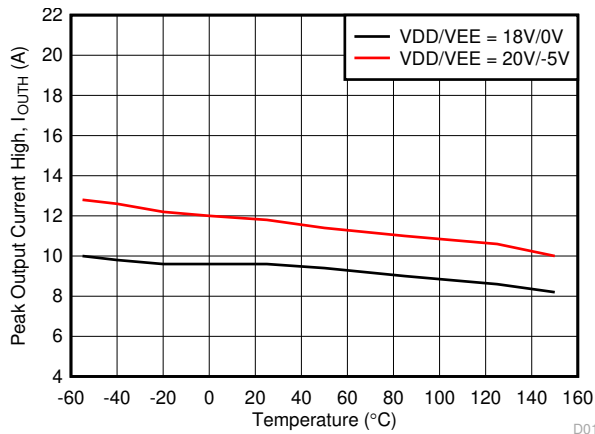

Figure 6-4. Output High Drive Current vs. Temperature

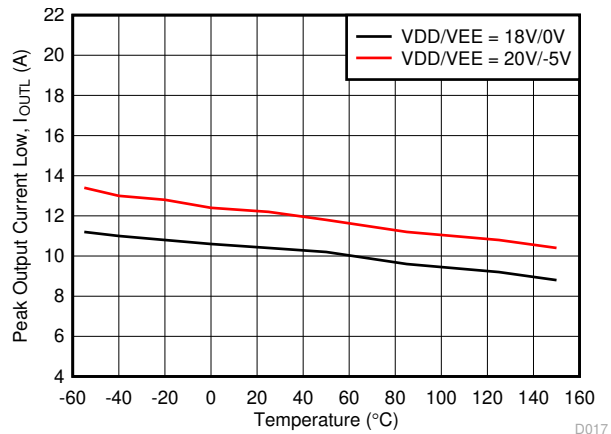

Figure 6-5. Output Low Driver Current vs. Temperature

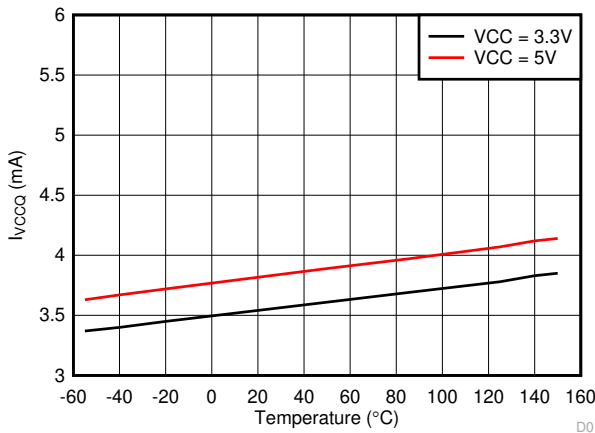

Figure 6-6. I_{VCCQ} Supply Current vs. Temperature
IN+ = High IN- = Low

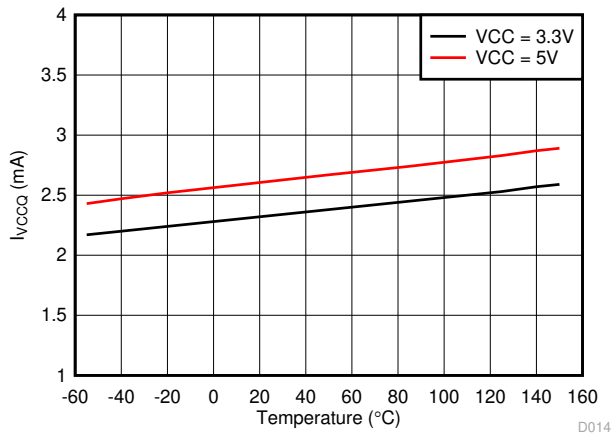

Figure 6-7. I_{VCCQ} Supply Current vs. Temperature
IN+ = Low IN- = Low

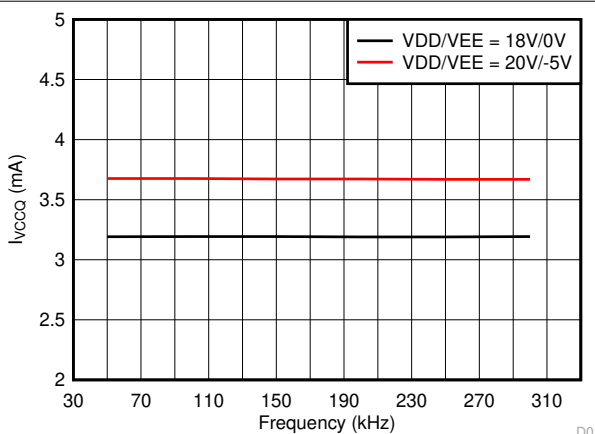

Figure 6-8. I_{VCCQ} Supply Current vs. Input Frequency

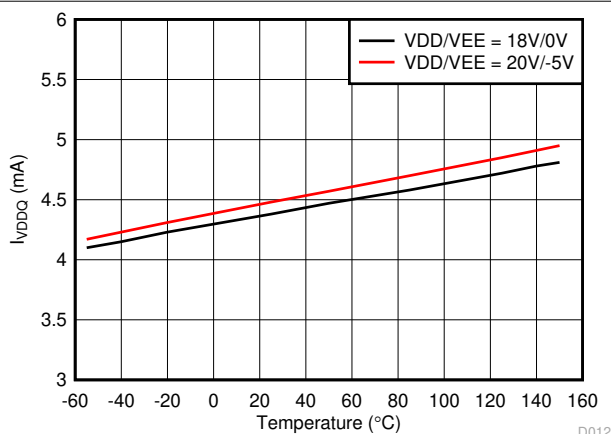

Figure 6-9. I_{VDDQ} Supply Current vs. Temperature
IN+ = High IN- = Low

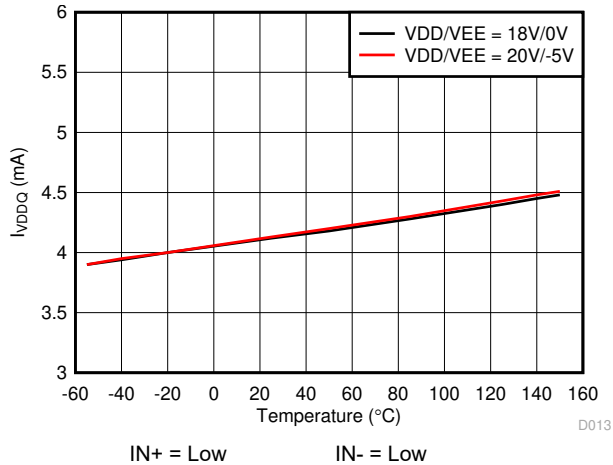

Figure 6-10. I_{VDDQ} Supply Current vs. Temperature

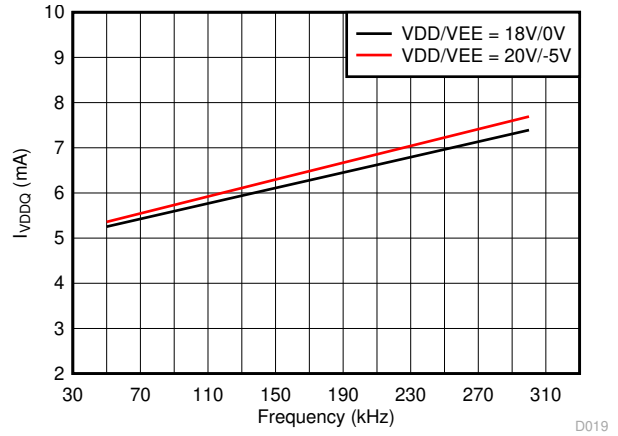

Figure 6-11. I_{VDDQ} Supply Current vs. Input Frequency

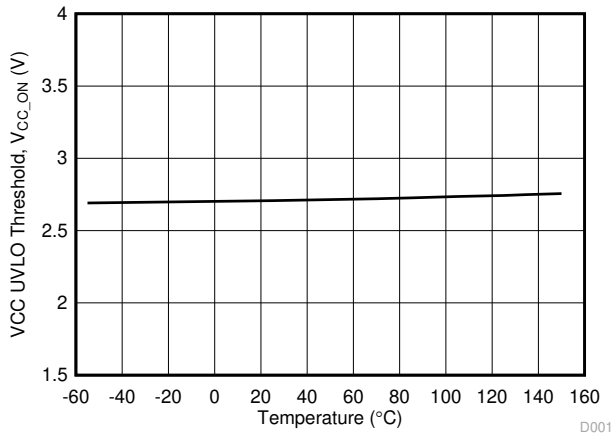

Figure 6-12. VCC UVLO vs. Temperature

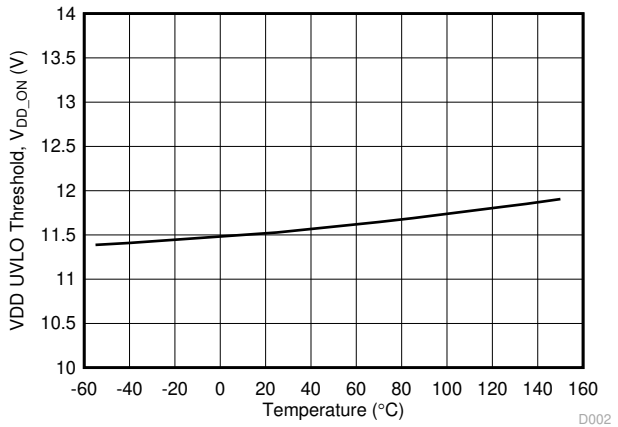

Figure 6-13. VDD UVLO vs. Temperature

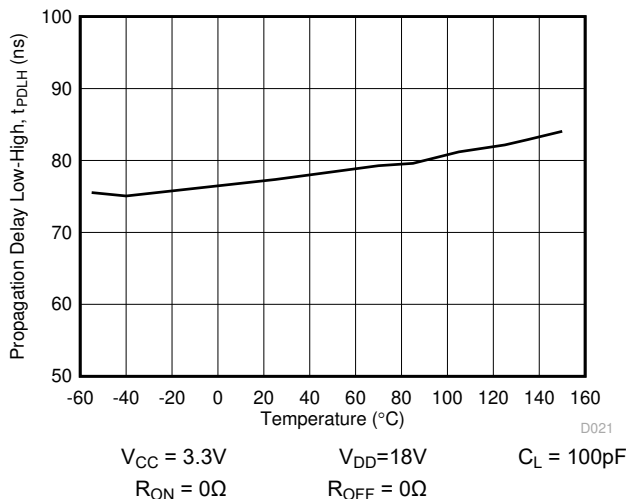

Figure 6-14. Propagation Delay t_{PDLH} vs. Temperature

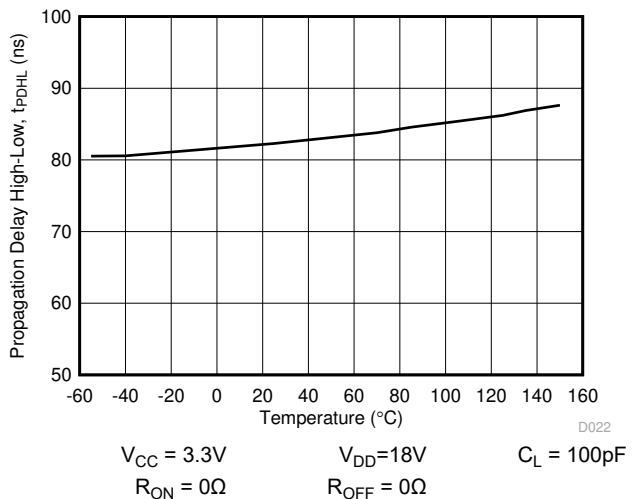
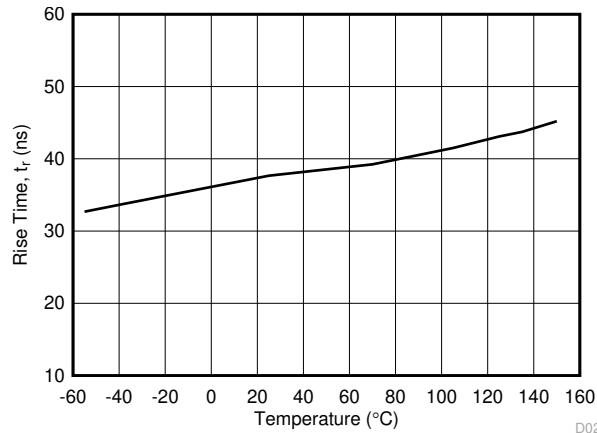
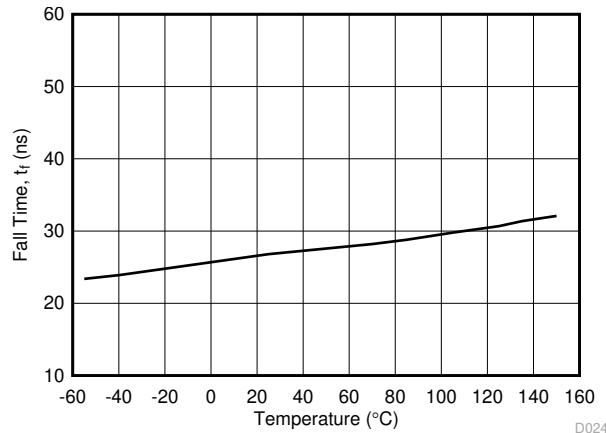

Figure 6-15. Propagation Delay t_{PDHL} vs. Temperature



$V_{CC} = 3.3V$ $V_{DD} = 18V$ $C_L = 10nF$
 $R_{ON} = 0\Omega$ $R_{OFF} = 0\Omega$

Figure 6-16. t_r Rise Time vs. Temperature



$V_{CC} = 3.3V$ $V_{DD} = 18V$ $C_L = 10nF$
 $R_{ON} = 0\Omega$ $R_{OFF} = 0\Omega$

Figure 6-17. t_f Fall Time vs. Temperature

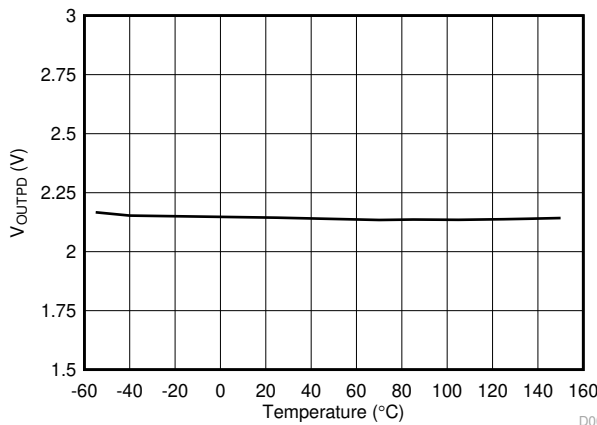

Figure 6-18. V_{OUTPD} Output Active Pulldown Voltage vs. Temperature

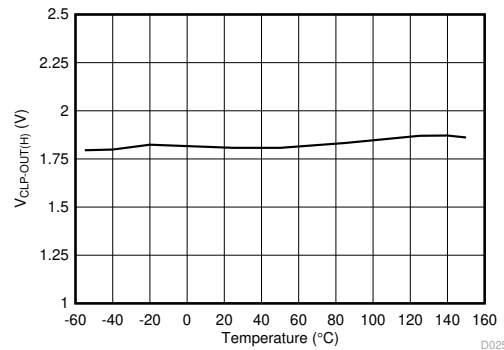

Figure 6-19. $V_{CLP-OUT(H)}$ Short Circuit Clamping Voltage vs. Temperature

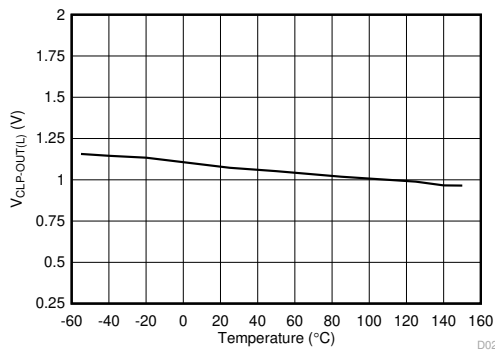

Figure 6-20. $V_{CLP-OUT(L)}$ Short Circuit Clamping Voltage vs. Temperature

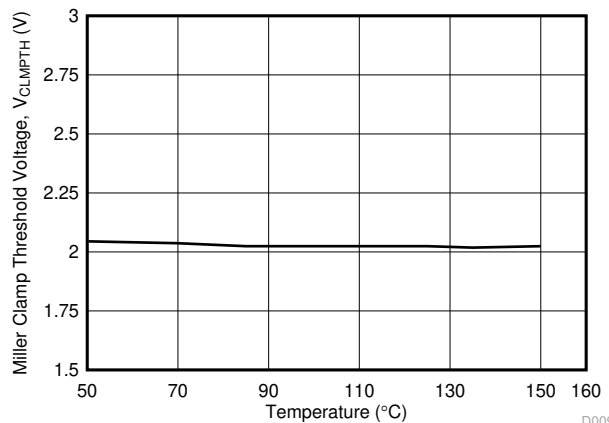

Figure 6-21. V_{CLMPH} Miller Clamp Threshold Voltage vs. Temperature

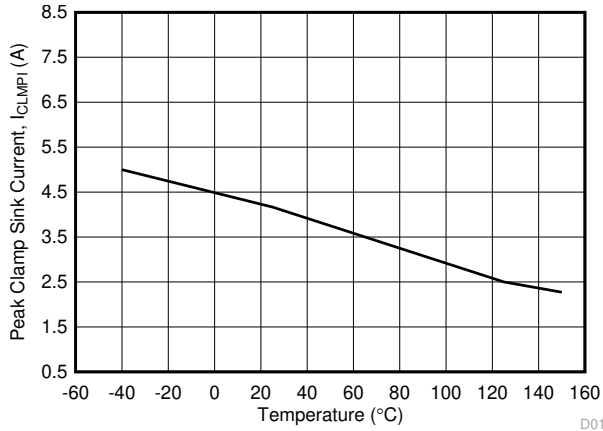

Figure 6-22. I_{CLMPI} Miller Clamp Sink Current vs. Temperature

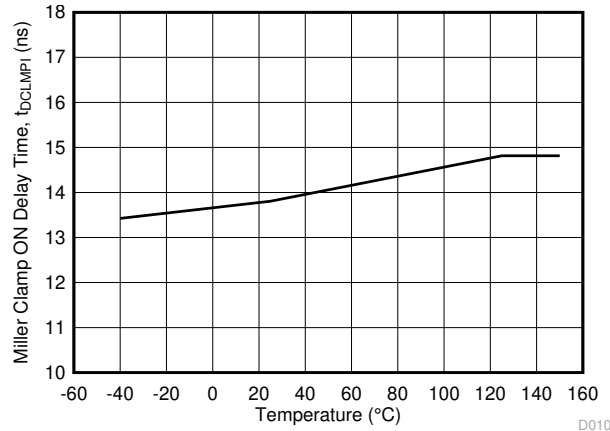

Figure 6-23. t_{DCLMPI} Miller Clamp ON Delay Time vs. Temperature

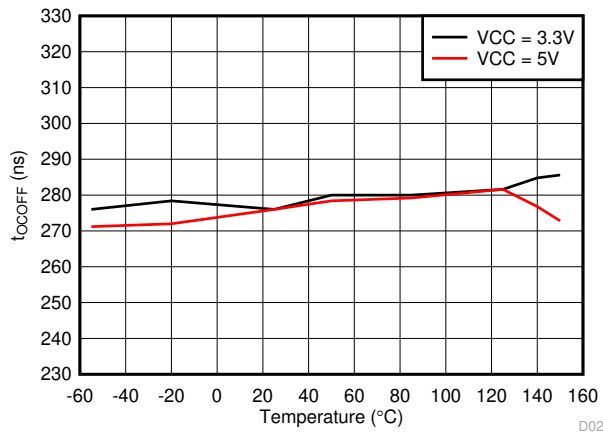

Figure 6-24. t_{OCOFF} OC Propagation Delay vs. Temperature

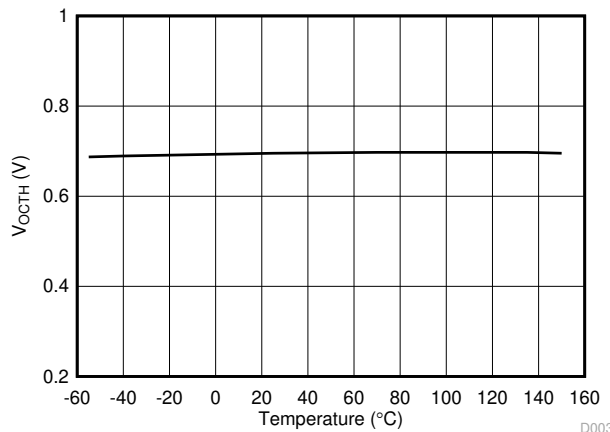

Figure 6-25. V_{OCTH} OC Detection Threshold vs. Temperature

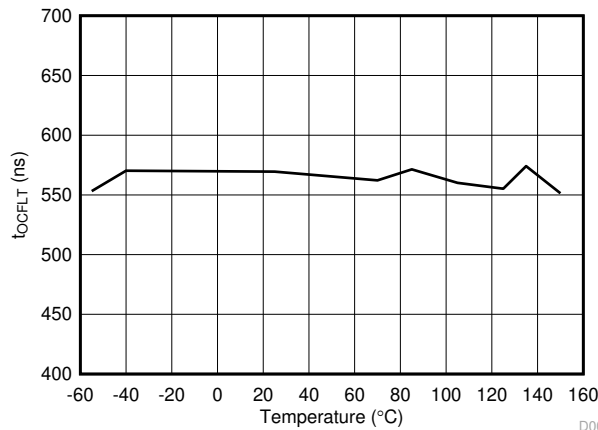

Figure 6-26. t_{OCLT} OC to \overline{FLT} Low Delay Time vs. Temperature

7 Parameter Measurement Information

7.1 Propagation Delay

7.1.1 Non-Inverting and Inverting Propagation Delay

Figure 7-1 shows the propagation delay measurement for non-inverting configurations. Figure 7-2 shows the propagation delay measurement with the inverting configurations.

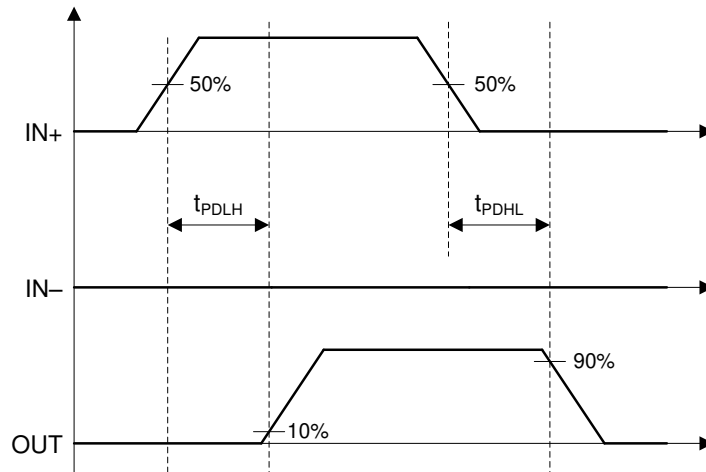

Figure 7-1. Non-inverting Logic Propagation Delay Measurement

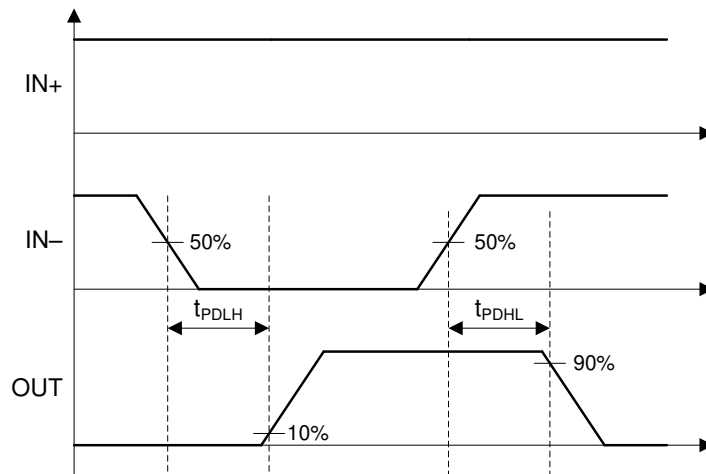

Figure 7-2. Inverting Logic Propagation Delay Measurement

7.2 Input Deglitch Filter

In order to increase the robustness of gate driver over noise transient and accidental small pulses on the input pins, i.e. IN+, IN-, RST/EN, a 40ns deglitch filter is designed to filter out the transients and make sure there is no faulty output responses or accidental driver malfunctions. When the IN+ or IN- PWM pulse is smaller than the input deglitch filter width, T_{INFIL} , there will be no responses on OUT drive signal. Figure 7-3 and Figure 7-4 shows the IN+ pin ON and OFF pulse deglitch filter effect. Figure 7-5 and Figure 7-6 shows the IN- pin ON and OFF pulse deglitch filter effect.

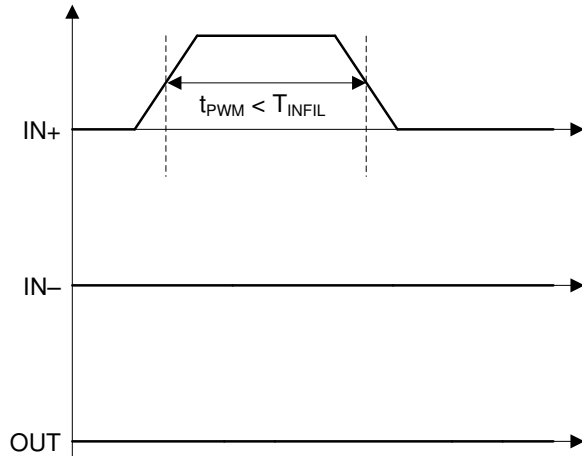

Figure 7-3. IN+ ON Deglitch Filter

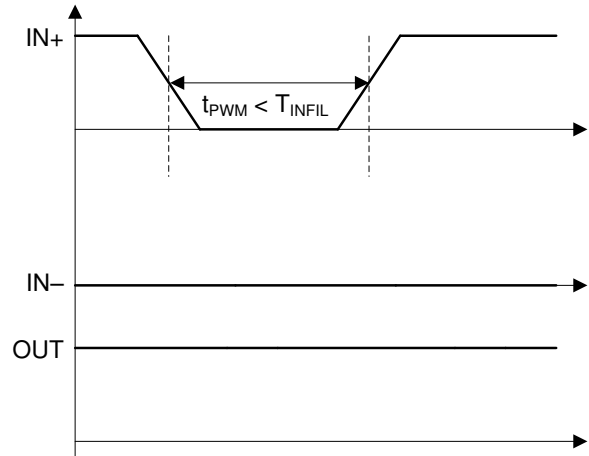

Figure 7-4. IN+ OFF Deglitch Filter

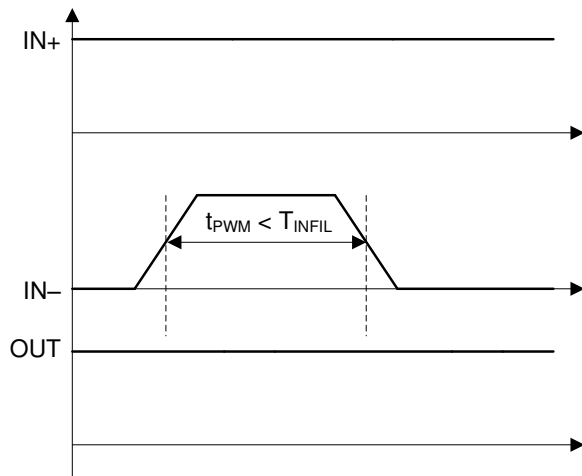

Figure 7-5. IN- ON Deglitch Filter

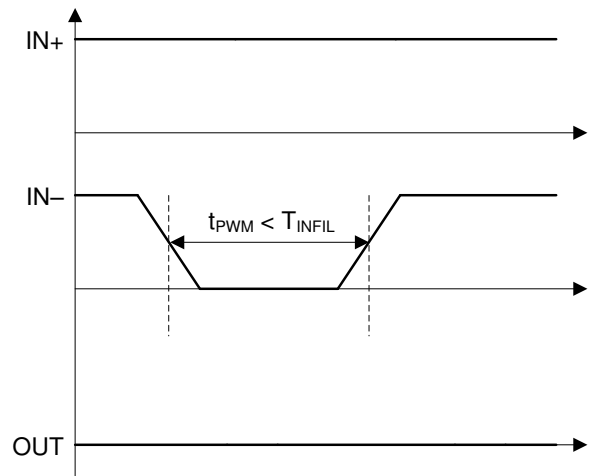

Figure 7-6. IN- OFF Deglitch Filter

7.3 Active Miller Clamp

7.3.1 Internal Active Miller Clamp

For gate driver application with unipolar bias supply or bipolar supply with small negative turn-off voltage, active Miller clamp can help add a additional low impedance path to bypass the Miller current and prevent the unintentional turn-on through the Miller capacitance. [Figure 7-7](#) shows the timing diagram for on-chip internal Miller clamp function.

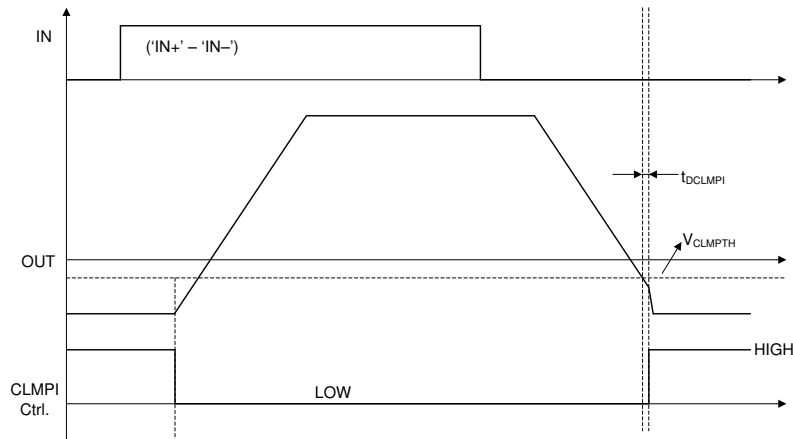

Figure 7-7. Timing Diagram for Internal Active Miller Clamp Function

7.4 Under Voltage Lockout (UVLO)

UVLO is one of the key protection features designed to protect the system in case of bias supply failures on VCC — primary side power supply, and VDD — secondary side power supply.

7.4.1 VCC UVLO

The VCC UVLO protection details are discussed in this section. [Figure 7-8](#) shows the timing diagram illustrating the definition of UVLO ON/OFF threshold, deglitch filter, response time, RDY and AIN–APWM.

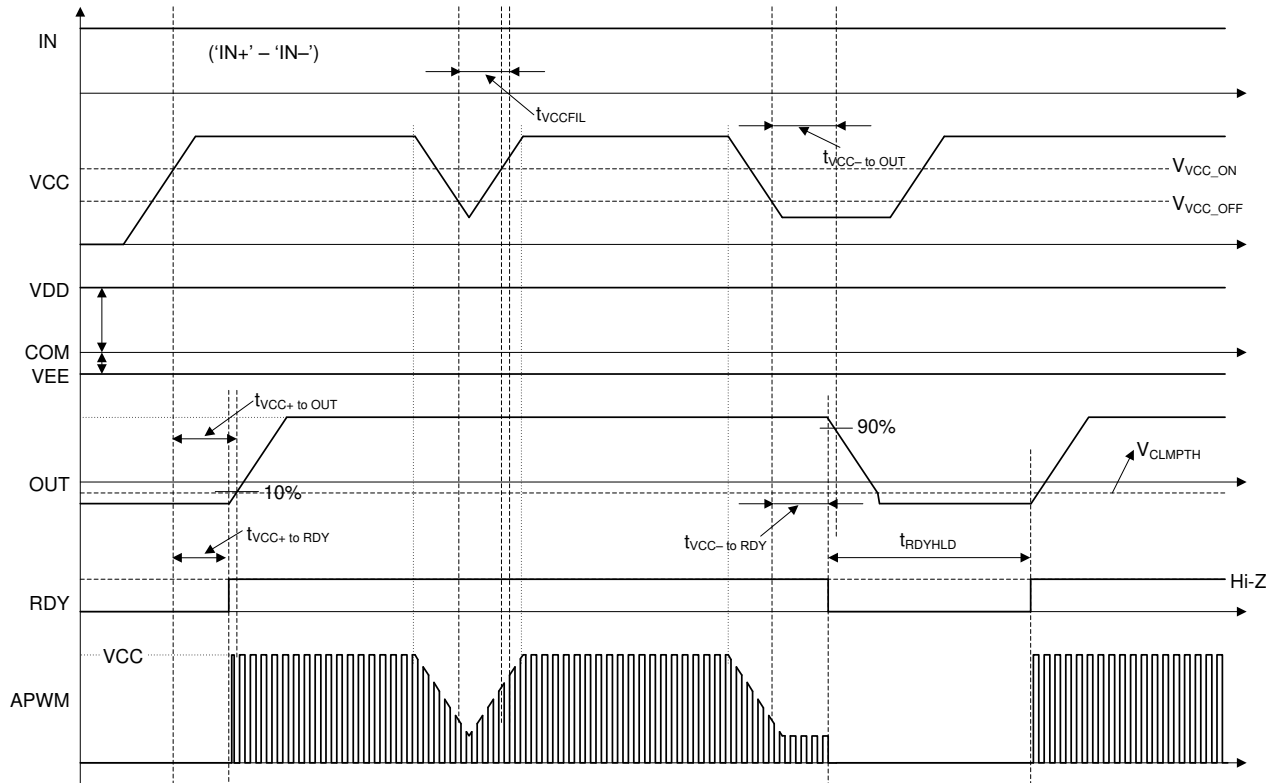

Figure 7-8. VCC UVLO Protection Timing Diagram

7.5 OC (Over Current) Protection

7.5.1 OC Protection with Soft Turn-OFF

OC Protection is used to sense the current of SiC-MOSFETs and IGBTs under over current or shoot-through condition. Figure 7-10 shows the timing diagram of OC operation with soft turn-off.

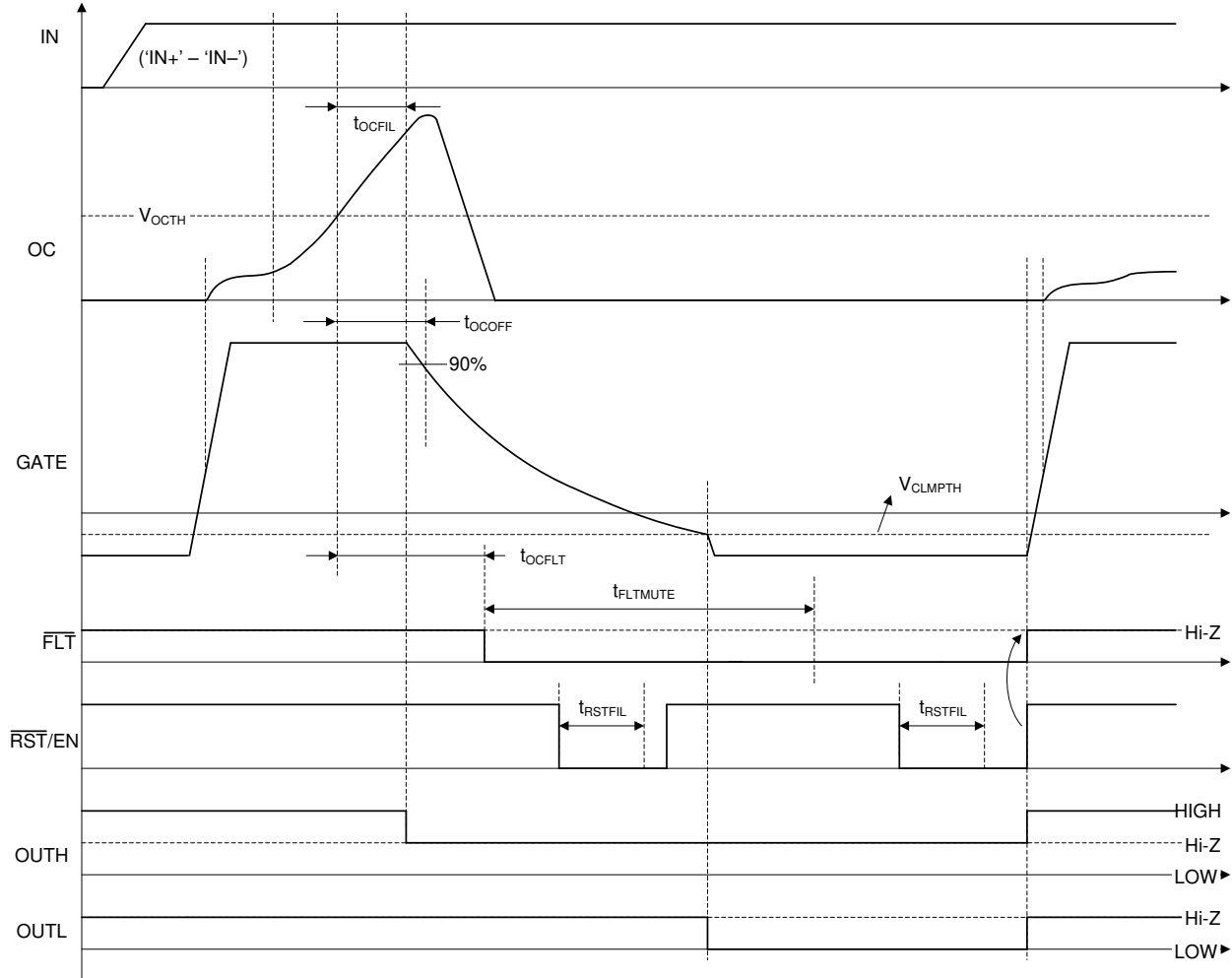

Figure 7-10. OC Protection with Soft Turn-OFF

8 Detailed Description

8.1 Overview

The UCC21710 device is an advanced isolated gate driver with state-of-art protection and sensing features for SiC MOSFETs and IGBTs. The device can support up to 2121V DC operating voltage based on SiC MOSFETs and IGBTs, and can be used to above 10kW applications such as HEV/EV traction inverter, motor drive, on-board and off-board battery charger, solar inverter, etc. The galvanic isolation is implemented by the capacitive isolation technology, which can realize a reliable reinforced isolation between the low voltage DSP/MCU and high voltage side.

The $\pm 10\text{A}$ peak sink and source current of UCC21710 can drive the SiC MOSFET modules and IGBT modules directly without an extra buffer. The driver can also be used to drive higher power modules or parallel modules with external buffer stage. The device can support up to $1.5\text{-kV}_{\text{RMS}}$ working voltage, $12.8\text{-kV}_{\text{PK}}$ surge immunity with longer than 40 years isolation barrier life. The strong drive strength helps to switch the device fast and reduce the switching loss. While the 150V/ns minimum CMTI guarantees the reliability of the system with fast switching speed. The small propagation delay and part-to-part skew can minimize the deadtime setting, so the conduction loss can be reduced.

The device includes extensive protection and monitor features to increase the reliability and robustness of the SiC MOSFET and IGBT based systems. The 12V output side power supply UVLO is suitable for switches with gate voltage $\geq 15\text{V}$. The active Miller clamp feature prevents the false turn on causing by Miller capacitance during fast switching. The device has the state-of-art overcurrent and short circuit detection time, and fault reporting function to the low voltage side DSP/MCU. The soft turn-off with soft turn off is triggered when the overcurrent or short circuit fault is detected, minimizing the short circuit energy while reducing the overshoot voltage on the switches.

The isolated analog to PWM sensor can be used as switch temperature sensing, DC bus voltage sensing, auxiliary power supply sensing, etc. The PWM signal can be fed directly to DSP/MCU or through a low-pass-filter as an analog signal.

8.2 Functional Block Diagram

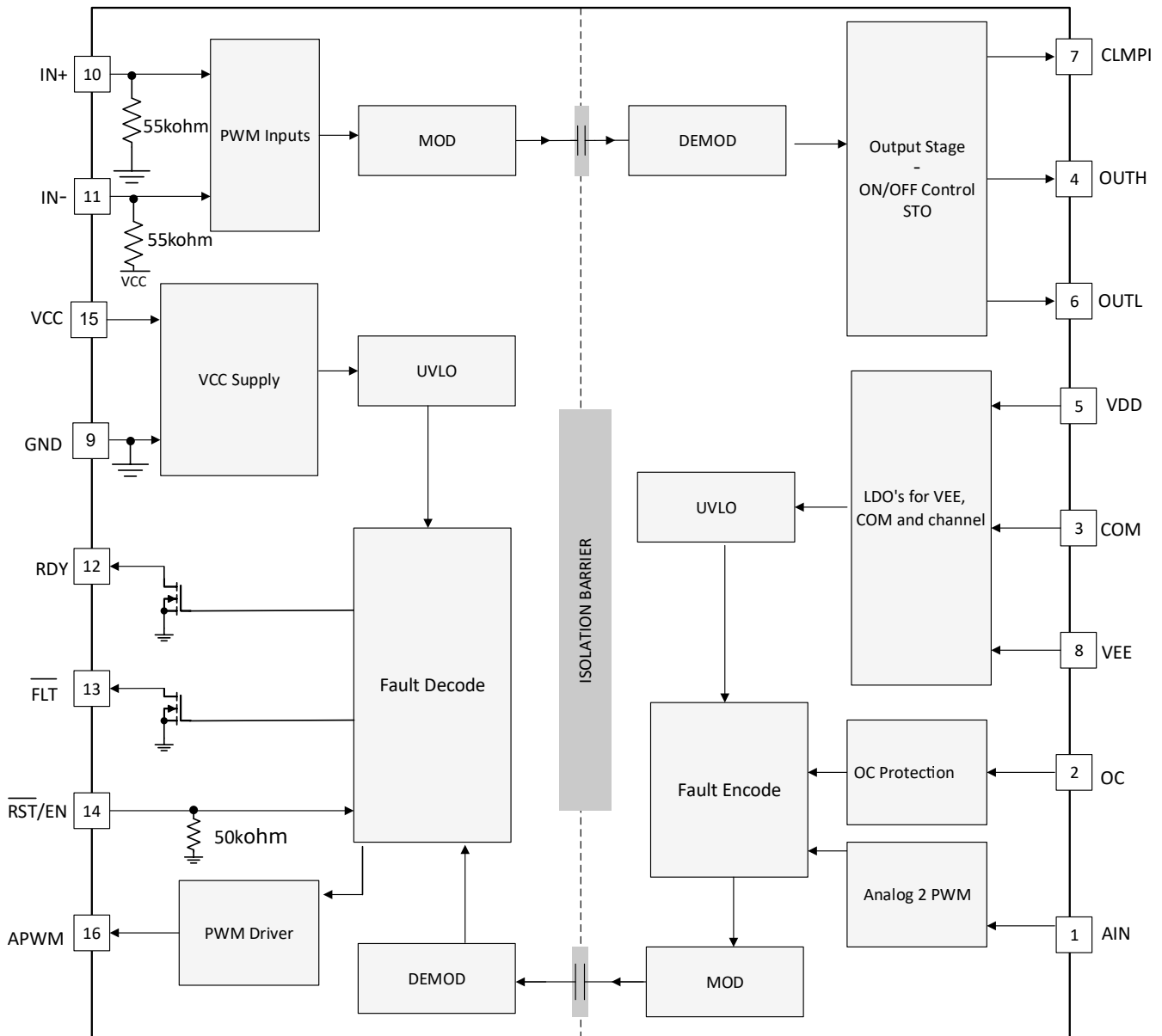

8.3 Feature Description

8.3.1 Power Supply

The input side power supply VCC can support a wide voltage range from 3V to 5.5V. The device supports both unipolar and bipolar power supply on the output side, with a wide range from 13V to 33V from VDD to VEE. The negative power supply with respect to switch source or emitter is usually adopted to avoid false turn on when the other switch in the phase leg is turned on. The negative voltage is especially important for SiC MOSFET due to its fast switching speed and low threshold voltage.

8.3.2 Driver Stage

UCC21710 has $\pm 10\text{A}$ peak drive strength and is suitable for high power applications. The high drive strength can drive a SiC MOSFET module, IGBT module or paralleled discrete devices directly without extra buffer stage. UCC21710 can also be used to drive higher power modules or parallel modules with extra buffer stage. Regardless of the values of VDD, the peak sink and source current can be kept at 10A. The driver features an important safety function wherein, when the input pins are in floating condition, the OUTH/OUTL is held in

LOW state. The split output of the driver stage is depicted in Figure 8-1. The driver has rail-to-rail output by implementing a hybrid pull-up structure with a P-Channel MOSFET in parallel with an N-Channel MOSFET, and an N-Channel MOSFET to pull-down. The pull-up NMOS is the same as the pull down NMOS, so the on resistance R_{NMOS} is the same as R_{OL} . The hybrid pull-up structure delivers the highest peak-source current when it is most needed, during the Miller plateau region of the power semiconductor turn-on transient. The R_{OH} in represents the on-resistance of the pull-up P-Channel MOSFET. However, the effective pull-up resistance is much smaller than R_{OH} . Since the pull-up N-Channel MOSFET has much smaller on-resistance than the P-Channel MOSFET, the pull-up N-Channel MOSFET dominates most of the turn-on transient, until the voltage on OUTH pin is about 3V below VDD voltage. The effective resistance of the hybrid pull-up structure during this period is about $2 \times R_{OL}$. Then the P-Channel MOSFET pulls up the OUTH voltage to VDD rail. The low pull-up impedance results in strong drive strength during the turn-on transient, which shortens the charging time of the input capacitance of the power semiconductor and reduces the turn on switching loss.

The pull-down structure of the driver stage is implemented solely by a pull-down N-Channel MOSFET. This MOSFET can ensure the OUTL voltage be pulled down to VEE rail. The low pull-down impedance not only results in high sink current to reduce the turn-off time, but also helps to increase the noise immunity considering the Miller effect.

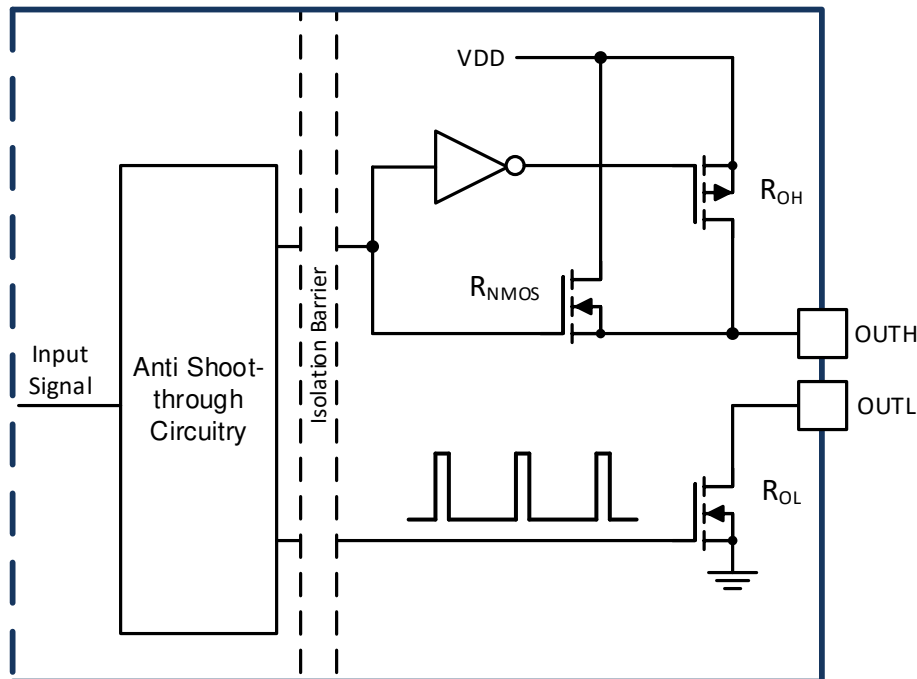

Figure 8-1. Gate Driver Output Stage

8.3.3 VCC and VDD Undervoltage Lockout (UVLO)

UCC21710 implements the internal UVLO protection feature for both input and output power supplies VCC and VDD. When the supply voltage is lower than the threshold voltage, the driver output is held as LOW. The output only goes HIGH when both VCC and VDD are out of the UVLO status. The UVLO protection feature not only reduces the power consumption of the driver itself during low power supply voltage condition, but also increases the efficiency of the power stage. For SiC MOSFET and IGBT, the on-resistance reduces while the gate-source voltage or gate-emitter voltage increases. If the power semiconductor is turned on with a low VDD value, the conduction loss increases significantly and can lead to a thermal issue and efficiency reduction of the power stage. UCC21710 implements 12V threshold voltage of VDD UVLO, with 800mV hysteresis. This threshold voltage is suitable for both SiC MOSFET and IGBT.

The UVLO protection block features with hysteresis and deglitch filter, which help to improve the noise immunity of the power supply. During the turn on and turn off switching transient, the driver sources and sinks a peak transient current from the power supply, which can result in sudden voltage drop of the power supply. With

hysteresis and UVLO deglitch filter, the internal UVLO protection block will ignore small noises during the normal switching transients.

The timing diagrams of the UVLO feature of VCC and VDD are shown in [Figure 7-8](#), and [Figure 7-9](#). The RDY pin on the input side is used to indicate the power good condition. The RDY pin is open drain. During UVLO condition, the RDY pin is held in low status and connected to GND. Normally the pin is pulled up externally to VCC to indicate the power good. The AIN-APWM function stops working during the UVLO status. The APWM pin on the input side will be held LOW.

8.3.4 Active Pulldown

UCC21710 implements an active pulldown feature to ensure the OUTH/OUTL pin clamping to VEE when the VDD is open. The OUTH/OUTL pin is in high-impedance status when VDD is open, the active pulldown feature can prevent the output be false turned on before the device is back to control.

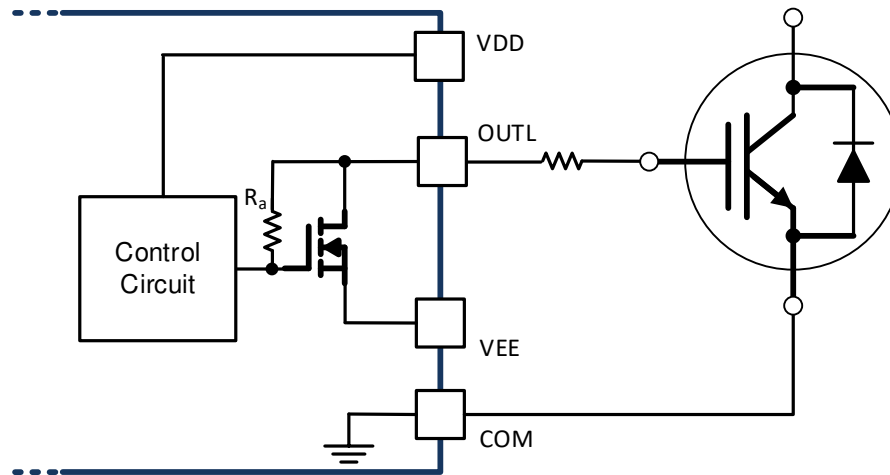

Figure 8-2. Active Pulldown

8.3.5 Short Circuit Clamping

During short circuit condition, the Miller capacitance can cause a current sinking to the OUTH/OUTL pin due to the high dV/dt and boost the OUTH/OUTL voltage. The short circuit clamping feature of UCC21710 can clamp the OUTH/OUTL pin voltage to be slightly higher than VDD, which can protect the power semiconductors from a gate-source and gate-emitter overvoltage breakdown. This feature is realized by an internal diode from the OUTH/OUTL to VDD.

8.3.7 Overcurrent and Short Circuit Protection

The UCC21710 implements a fast overcurrent and short circuit protection feature to protect the SiC MOSFET or IGBT from catastrophic breakdown during fault. The OC pin of the device has a typical 0.7V threshold with respect to COM, source or emitter of the power semiconductor. When the input is in floating condition, or the output is held in low state, the OC pin is pulled down by an internal MOSFET and held in LOW state, which prevents the overcurrent and short circuit fault from false triggering. The OC pin is in high-impedance state when the output is in high state, which means the overcurrent and short circuit protection feature only works when the power semiconductor is in on state. The internal pulldown MOSFET helps to discharge the voltage of OC pin when the power semiconductor is turned off.

The overcurrent and short circuit protection feature can be used to SiC MOSFET module or IGBT module with SenseFET, traditional desaturation circuit and shunt resistor in series with the power loop for lower power applications. For SiC MOSFET module or IGBT module with SenseFET, the SenseFET integrated in the module can scale down the drain current or collector current. With an external high precision sense resistor, the drain current or collector current can be accurately measured. If the voltage of the sensed resistor higher than the overcurrent threshold V_{OCTH} is detected, the soft turn-off is initiated. A fault will be reported to the input side \overline{FLT} pin to DSP/MCU. The output is held to LOW after the fault is detected, and can only be reset by the $\overline{RST/EN}$ pin. The state-of-art overcurrent and short circuit detection time helps to ensure a short shutdown time for SiC MOSFET and IGBT.

The overcurrent and short circuit protection feature can also be paired with desaturation circuit and shunt resistors. The DESAT threshold can be programmable in this case, which increases the versatility of the device. Detailed application diagrams of desaturation circuit and shunt resistor will be given in [Section 9.2.2.6](#).

- High current and high di/dt during the overcurrent and short circuit fault can cause a voltage bounce on shunt resistor's parasitic inductance and board layout parasitic, which results in false trigger of OC pin. High precision, low ESL and small value resistor must be used in this approach.
- Shunt resistor approach is not recommended for high power applications and short circuit protection of the low power applications.

The detailed applications of the overcurrent and short circuit feature will be discussed in the Application and Implementation section.

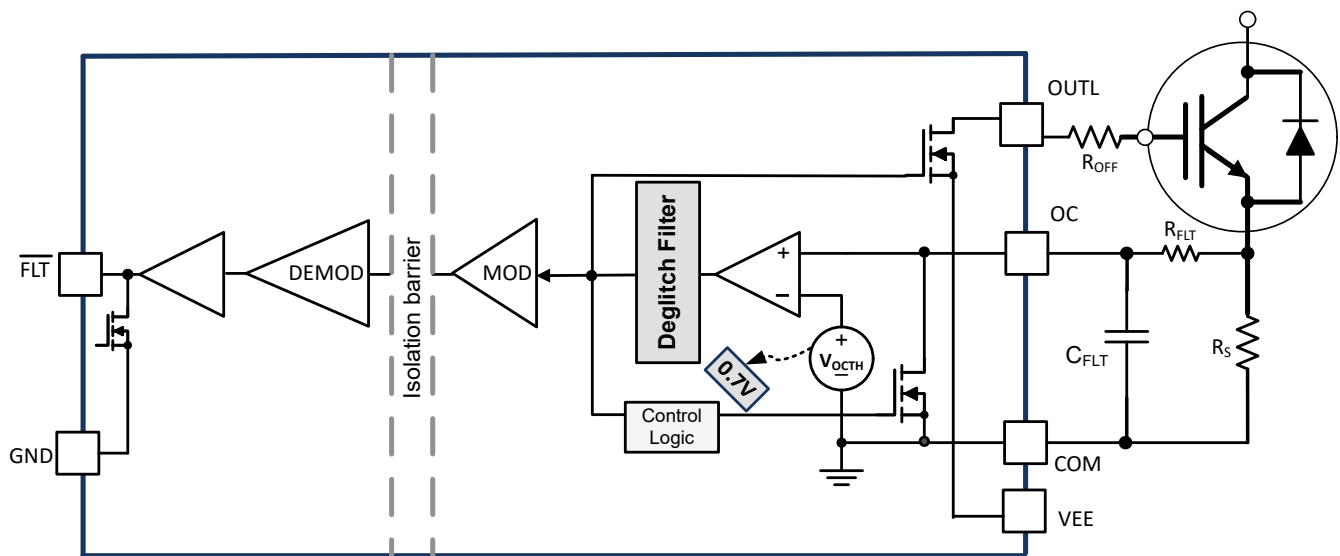

Figure 8-5. Overcurrent and Short Circuit Protection

8.3.8 Soft Turn-off

UCC21710 initiates a soft turn-off when the overcurrent and short circuit protection is triggered. When the overcurrent and short circuit fault happens, the power power semiconductor transits from the linear region to

the saturation region very fast. The channel current is controlled by the gate voltage. By pulling down the gate voltage with a soft turn off current, the di/dt of the channel current is controlled by the gate voltage and decreasing in a soft manner, thus the overshoot of the power semiconductor is limited and prevents the overvoltage breakdown. The timing diagram of soft turn-off shows in Figure 7-10.

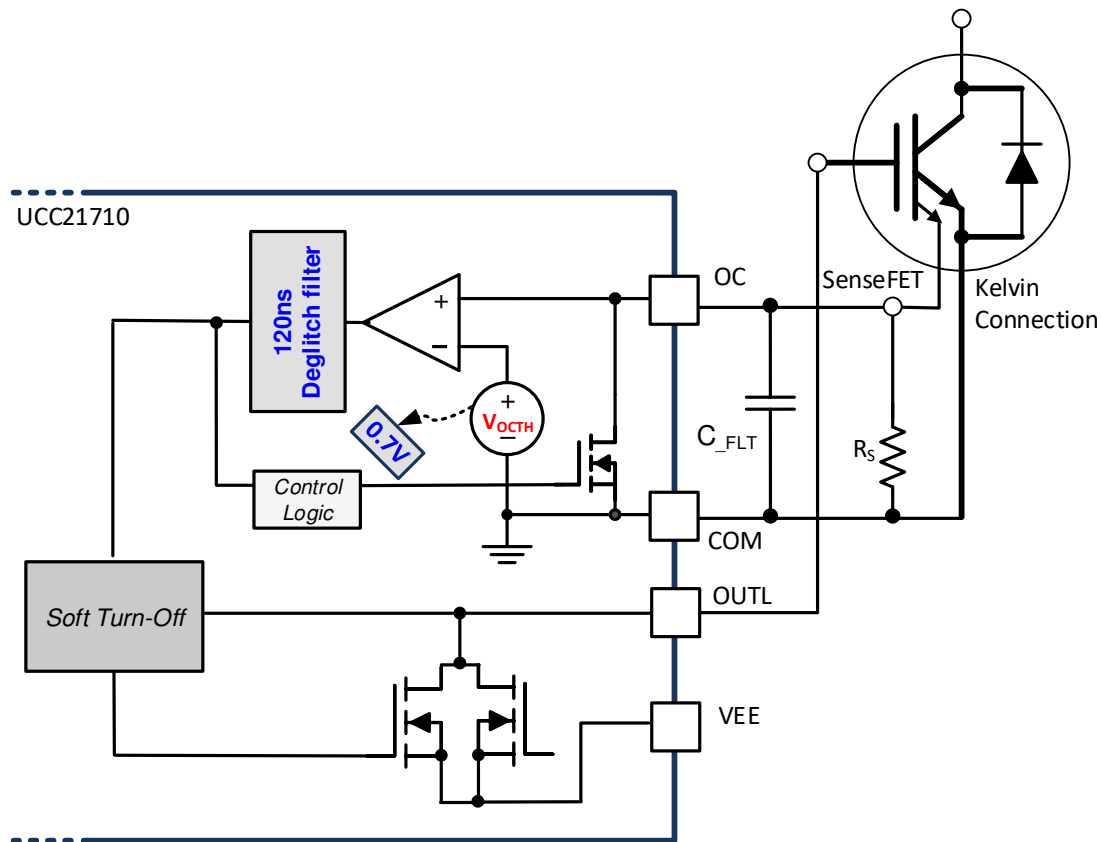

Figure 8-6. Soft Turn-off

8.3.9 Fault ($\overline{\text{FLT}}$, Reset and Enable ($\overline{\text{RST/EN}}$)

The $\overline{\text{FLT}}$ pin of UCC21710 is open drain and can report a fault signal to the DSP/MCU when the fault is detected through the OC pin. The $\overline{\text{FLT}}$ pin will be pulled down to GND after the fault is detected, and is held low until a reset signal is received from $\overline{\text{RST/EN}}$. The device has a fault mute time t_{FLTMUTE} , within which the device ignores any reset signal.

The $\overline{\text{RST/EN}}$ is pulled down internally by a 50k Ω resistor, and is thus disabled by default when this pin is floating. It must be pulled up externally to enable the driver. The pin has two purposes:

- To reset the $\overline{\text{FLT}}$ pin. To reset, then $\overline{\text{RST/EN}}$ pin is pulled low; if the pin is set and held in low state for more than t_{RSTFIL} after the mute time t_{FLTMUTE} , then the fault signal is reset and $\overline{\text{FLT}}$ is reset back to the high impedance status at the rising edge of the input signal at $\overline{\text{RST/EN}}$ pin.
- Enable and shutdown the device. If the $\overline{\text{RST/EN}}$ pin is pulled low for longer than t_{RSTFIL} , the driver will be disabled and OUTL will be activated to pull down the gate of the IGBT or SiC MOSFET. The pin must be pulled up externally to enable the part, otherwise the device is disabled by default.

8.3.10 Isolated Analog to PWM Signal Function

The UCC21710 features an isolated analog to PWM signal function from AIN to APWM pin, which allows the isolated temperature sensing, high voltage dc bus voltage sensing, etc. An internal current source I_{AIN} in AIN pin is implemented in the device to bias an external thermal diode or temperature sensing resistor. The UCC21710 encodes the voltage signal V_{AIN} to a PWM signal, passing through the reinforced isolation barrier, and output to APWM pin on the input side. The PWM signal can either be transferred directly to DSP/MCU to

calculate the duty cycle, or filtered by a simple RC filter as an analog signal. The AIN voltage input range is from 0.6V to 4.5V, and the corresponding duty cycle of the APWM output ranges from 88% to 10%. The duty cycle increases linearly from 10% to 88% while the AIN voltage decreases from 4.5V to 0.6V. This corresponds to the temperature coefficient of the negative temperature coefficient (NTC) resistor and thermal diode. When AIN is floating, the AIN voltage is 5V and the APWM operates at 400kHz with approximately 10% duty cycle. The duty cycle absolute error is $\pm 1.5\%$ at 0.6V and 2.5V and is $+1.5\% / -2.5\%$ at 4.5V across both process and temperature. The in-system accuracy can be improved using calibration to account for any offset. The accuracy of the internal current source I_{AIN} is $\pm 3\%$ across process and temperature.

The isolated analog to PWM signal feature can also support other analog signal sensing, such as the high voltage DC bus voltage, etc. The internal current source I_{AIN} should be taken into account when designing the potential divider if sensing a high voltage.

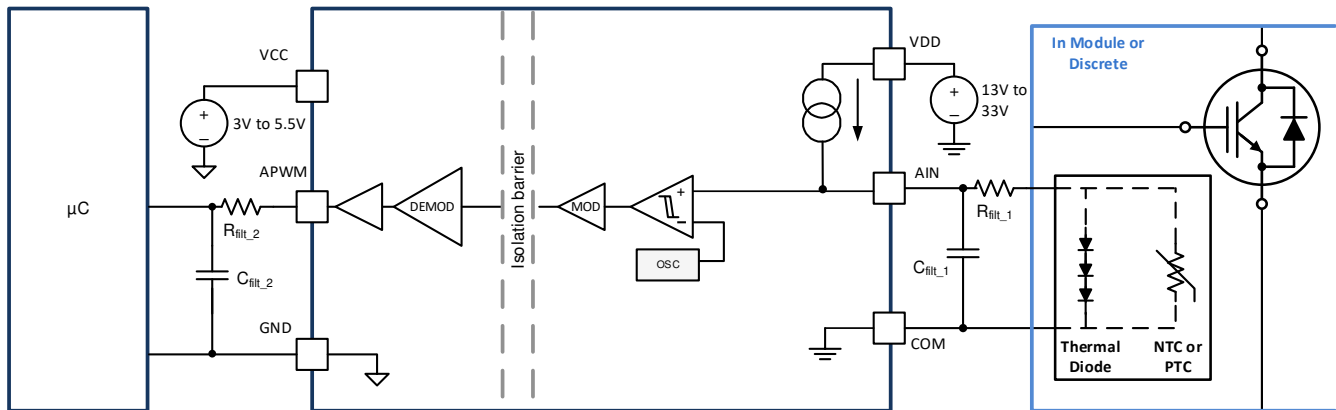

Figure 8-7. Isolated Analog to PWM Signal

8.4 Device Functional Modes

The [Table 8-1](#) lists the device function.

Table 8-1. Function Table

INPUT							OUTPUT				
VCC	VDD	VEE	IN+	IN-	RST/EN	AIN	RDY	FLT	OUTH/ OUTL	CLMPI	APWM
PU	PD	PU	X	X	X	X	Low	HiZ	Low	Low	Low
PD	PU	PU	X	X	X	X	Low	HiZ	Low	Low	Low
PU	PU	PU	X	X	Low	X	HiZ	HiZ	Low	Low	Low
PU	Open	PU	X	X	X	X	Low	HiZ	HiZ	HiZ	HiZ
PU	PU	Open	X	X	X	X	Low	HiZ	Low	Low	Low
PU	PU	PU	Low	X	High	X	HiZ	HiZ	Low	Low	P*
PU	PU	PU	X	High	High	X	HiZ	HiZ	Low	Low	P*
PU	PU	PU	High	High	High	X	HiZ	HiZ	Low	Low	P*
PU	PU	PU	High	Low	High	X	HiZ	HiZ	High	HiZ	P*

PU: Power Up ($V_{CC} \geq 2.85\text{ V}$, $V_{DD} \geq 13.1\text{ V}$, $V_{EE} \leq 0\text{ V}$); PD: Power Down ($V_{CC} \leq 2.35\text{ V}$, $V_{DD} \leq 9.9\text{ V}$); X: Irrelevant; P*: PWM Pulse; HiZ: High Impedance

9 Applications and Implementation

Note

Information in the following applications sections is not part of the TI component specification, and TI does not warrant its accuracy or completeness. TI's customers are responsible for determining suitability of components for their purposes, as well as validating and testing their design implementation to confirm system functionality.

9.1 Application Information

The UCC21710 device is very versatile because of the strong drive strength, wide range of output power supply, high isolation ratings, high CMTI and superior protection and sensing features. The 1.5-kVRMS working voltage and 12.8-kVPK surge immunity can support up both SiC MOSFET and IGBT modules with DC bus voltage up to 2121V. The device can be used in both low power and high power applications such as the traction inverter in HEV/EV, on-board charger and charging pile, motor driver, solar inverter, industrial power supplies and etc. The device can drive the high power SiC MOSFET module, IGBT module or paralleled discrete device directly without external buffer drive circuit based on NPN/PNP bipolar transistor in totem-pole structure, which allows the driver to have more control to the power semiconductor and saves the cost and space of the board design. UCC21710 can also be used to drive very high power modules or paralleled modules with external buffer stage. The input side can support power supply and microcontroller signal from 3.3V to 5V, and the device level shifts the signal to output side through reinforced isolation barrier. The device has wide output power supply range from 13V to 33V and support wide range of negative power supply. This allows the driver to be used in SiC MOSFET applications, IGBT application and many others. The 12V UVLO benefits the power semiconductor with lower conduction loss and improves the system efficiency. As a reinforced isolated single channel driver, the device can be used to drive either a low-side or high-side driver.

UCC21710 device features extensive protection and monitoring features, which can monitor, report and protect the system from various fault conditions.

- Fast detection and protection for the overcurrent and short circuit fault. The feature is preferable in a split source SiC MOSFET module or a split emitter IGBT module. For the modules with no integrated current mirror or paralleled discrete semiconductors, the traditional desaturation circuit can be modified to implement short circuit protection. The semiconductor is shutdown when the fault is detected and $\overline{\text{FLT}}$ pin is pulled down to indicate the fault detection. The device is latched unless reset signal is received from the $\overline{\text{RST/EN}}$ pin.
- Soft turn-off feature to protect the power semiconductor from catastrophic breakdown during overcurrent and short circuit fault. The shutdown energy can be controlled while the overshoot of the power semiconductor is limited.
- UVLO detection to protect the semiconductor from excessive conduction loss. Once the device is detected to be in UVLO mode, the output is pulled down and RDY pin indicates the power supply is lost. The device is back to normal operation mode once the power supply is out of the UVLO status. The power good status can be monitored from the RDY pin.
- Analog signal sensing with isolated analog to PWM signal feature. This feature allows the device to sense the temperature of the semiconductor from the thermal diode or temperature sensing resistor, or dc bus voltage with resistor divider. A PWM signal is generated on the low voltage side with reinforced isolated from the high voltage side. The signal can be fed back to the microcontroller for the temperature monitoring, voltage monitoring and etc.
- The active Miller clamp feature protects the power semiconductor from false turn on by driving an external MOSFET. This feature allows the flexibility of the board layout design and the pulldown strength of Miller clamp FET.
- Enable and disable function through the $\overline{\text{RST/EN}}$ pin.
- Short circuit clamping.
- Active pulldown.

9.2 Typical Application

Figure 9-1 shows the typical application of a half bridge using two UCC21710 isolated gate drivers. The half bridge is a basic element in various power electronics applications such as traction inverter in HEV/EV to convert the DC current of the electric vehicle's battery to the AC current to drive the electric motor in the propulsion system. The topology can also be used in motor drive applications to control the operating speed and torque of the AC motors.

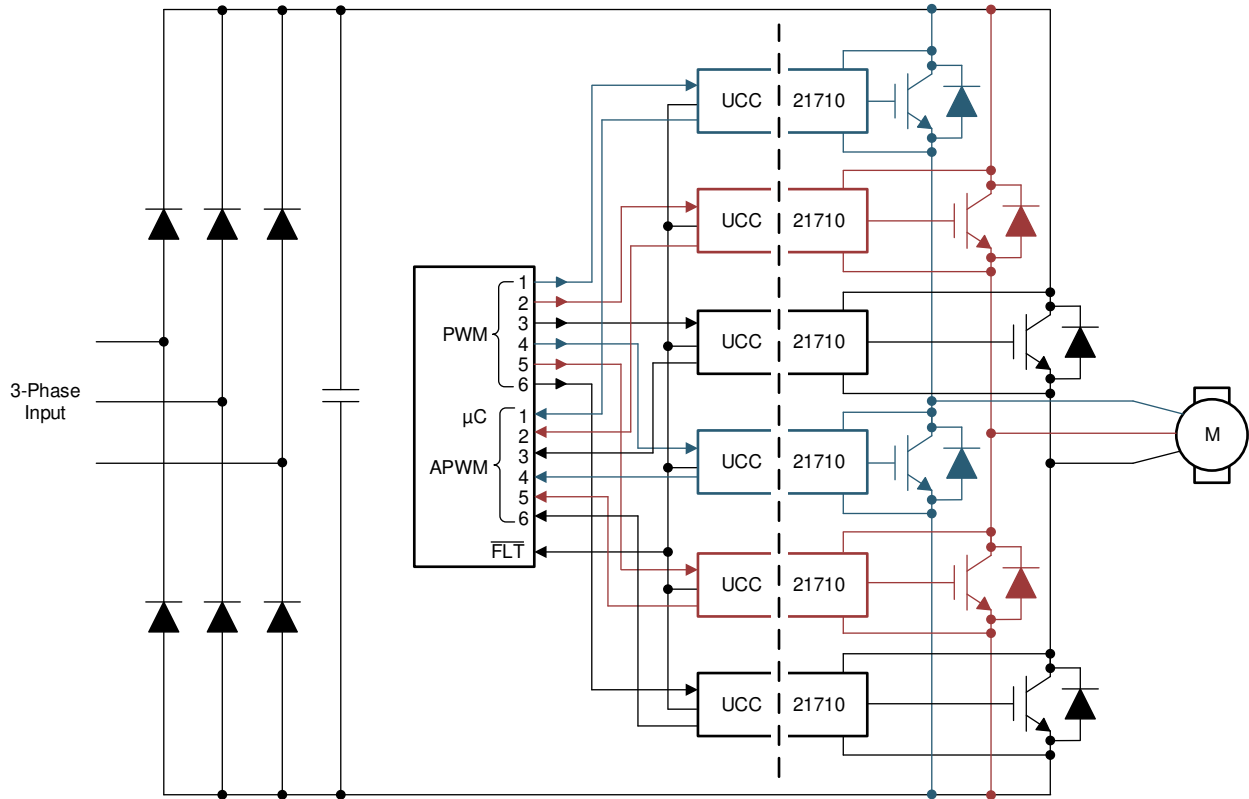

Figure 9-1. Typical Application Schematic

9.2.1 Design Requirements

The design of the power system for end equipment should consider some design requirements to ensure the reliable operation of UCC1710 through the load range. The design considerations include the peak source and sink current, power dissipation, overcurrent and short circuit protection, AIN-APWM function for analog signal sensing and etc.

A design example for a half bridge based on IGBT is given in this subsection. The design parameters are show in [Table 9-1](#).

Table 9-1. Design Parameters

Parameter	Value
Input Supply Voltage	5V
IN-OUT Configuration	Non-inverting
Positive Output Voltage VDD	15V
Negative Output Voltage VEE	-5V
DC Bus Voltage	800V
Peak Drain Current	300A
Switching Frequency	50kHz

Table 9-1. Design Parameters (continued)

Parameter	Value
Switch Type	IGBT Module

9.2.2 Detailed Design Procedure

9.2.2.1 Input filters for IN+, IN- and $\overline{RST/EN}$

In the applications of traction inverter or motor drive, the power semiconductors are in hard switching mode. With the strong drive strength of UCC21710, the dV/dt can be high, especially for SiC MOSFET. Noise can not only be coupled to the gate voltage due to the parasitic inductance, but also to the input side as the non-ideal PCB layout and coupled capacitance.

UCC21710 features a 40ns internal deglitch filter to IN+, IN- and $\overline{RST/EN}$ pin. Any signal less than 40ns can be filtered out from the input pins. For noisy systems, external low pass filter can be added externally to the input pins. Adding low pass filters to IN+, IN- and $\overline{RST/EN}$ pins can effectively increase the noise immunity and increase the signal integrity. When not in use, the IN+, IN- and $\overline{RST/EN}$ pins should not be floating. IN- should be tied to GND if only IN+ is used for non-inverting input to output configuration. The purpose of the low pass filter is to filter out the high frequency noise generated by the layout parasitics. While choosing the low pass filter resistors and capacitors, both the noise immunity effect and delay time should be considered according to the system requirements.

9.2.2.2 PWM Interlock of IN+ and IN-

UCC21710 features the PWM interlock for IN+ and IN- pins, which can be used to prevent the phase leg shoot through issue. As shown in Function Table, the output is logic low while both IN+ and IN- are logic high. To utilize the PWM interlock function, the PWM signal of the other switch in the phase leg can be sent to the IN- pin. As shown in PWM Interlock for a Half Bridge, the PWM_T is the PWM signal to top side switch, the PWM_B is the PWM signal to bottom side switch. For the top side gate driver, the PWM_T signal is given to the IN+ pin, while the PWM_B signal is given to the IN- pin; for the bottom side gate driver, the PWM_B signal is given to the IN+ pin, while PWM_T signal is given to the IN- pin. When both PWM_T and PWM_B signals are high, the outputs of both gate drivers are logic low to prevent the shoot through condition.

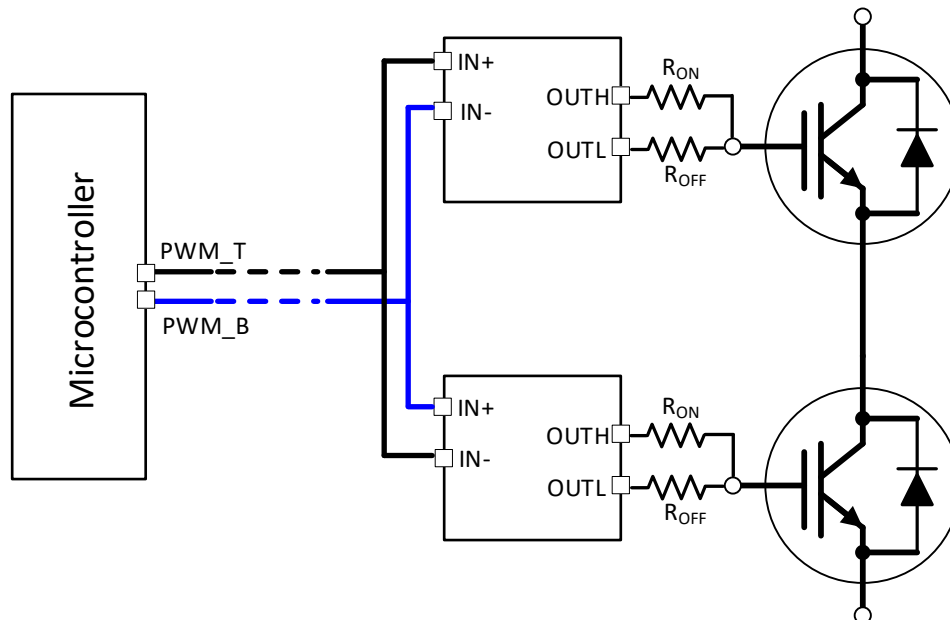
**Figure 9-2. PWM Interlock for a Half Bridge**

9.2.2.3 \overline{FLT} , RDY and $\overline{RST/EN}$ Pin Circuitry

Both \overline{FLT} and RDY pin are open-drain output. The $\overline{RST/EN}$ pin has 50k Ω internal pulldown resistor, so the driver is in OFF status if the $\overline{RST/EN}$ pin is not pulled up externally. A 5k Ω resistor can be used as pullup resistor for the \overline{FLT} , RDY and $\overline{RST/EN}$ pins.

To improve the noise immunity due to the parasitic coupling and common mode noise, low pass filters can be added between the \overline{FLT} , RDY and $\overline{RST/EN}$ pins and the microcontroller. A filter capacitor between 100pF to 300pF can be added.

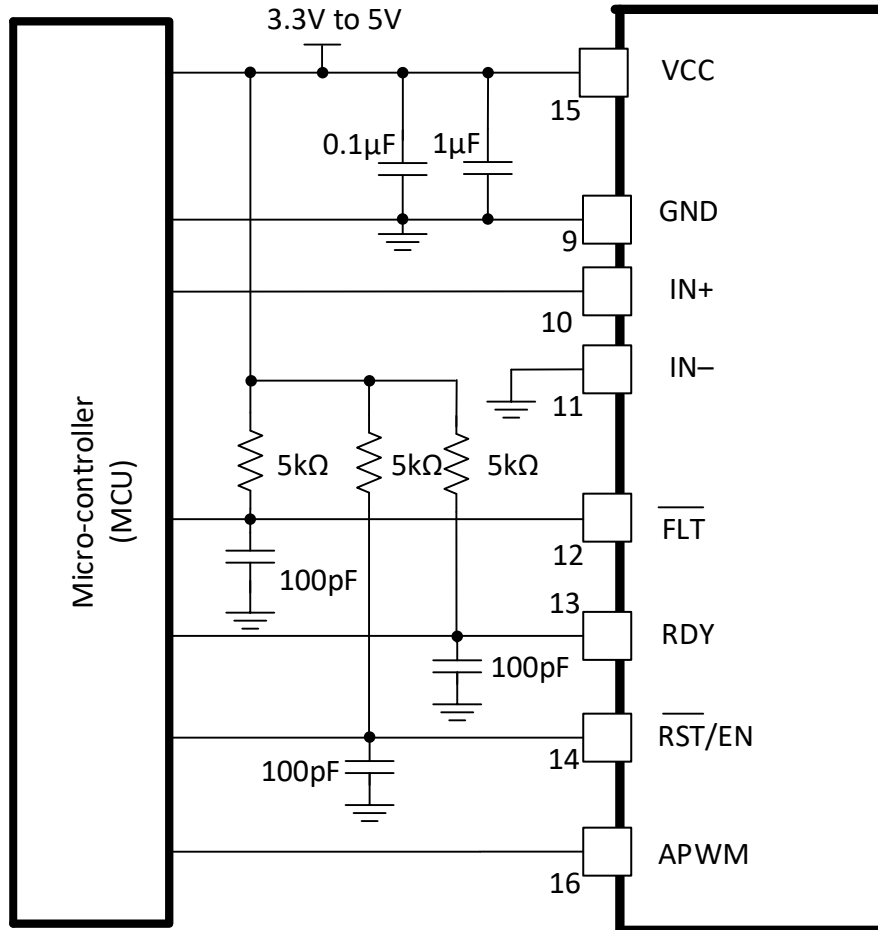

Figure 9-3. \overline{FLT} , RDY and $\overline{RST/EN}$ Pins Circuitry

9.2.2.4 $\overline{RST/EN}$ Pin Control

$\overline{RST/EN}$ pin has two functions. It is used to enable or shutdown the outputs of the driver and to reset the fault signaled on the \overline{FLT} pin after OC is detected. $\overline{RST/EN}$ pin needs to be pulled up to enable the device; when the pin is pulled down, the device is in disabled status. By default the driver is disabled with the internal 50k Ω pulldown resistor at this pin.

When the driver is latched after overcurrent or short circuit fault is detected, the \overline{FLT} pin and output are latched low and need to be reset by the $\overline{RST/EN}$ pin. The microcontroller must send a signal to $\overline{RST/EN}$ pin after the fault to reset the driver. The driver will not respond until after the mute time $t_{FLTMUTE}$. The reset signal must be held low for at least t_{RSTFIL} after the mute time.

This pin can also be used to automatically reset the driver. The continuous input signal IN+ or IN- can be applied to $\overline{RST/EN}$ pin. There is no separate reset signal from the microcontroller when configuring the driver this way. If the PWM is applied to the non-inverting input IN+, then IN+ can also be tied to $\overline{RST/EN}$ pin. If the PWM is applied to the inverting input IN-, then a NOT logic is needed between the PWM signal from the microcontroller

and the $\overline{\text{RST/EN}}$ pin. Using either configuration results in the driver being reset in every switching cycle without an extra control signal from microcontroller tied to $\overline{\text{RST/EN}}$ pin. One must ensure the PWM off-time is greater than t_{RSTFIL} in order to reset the driver in cause of a OC fault.

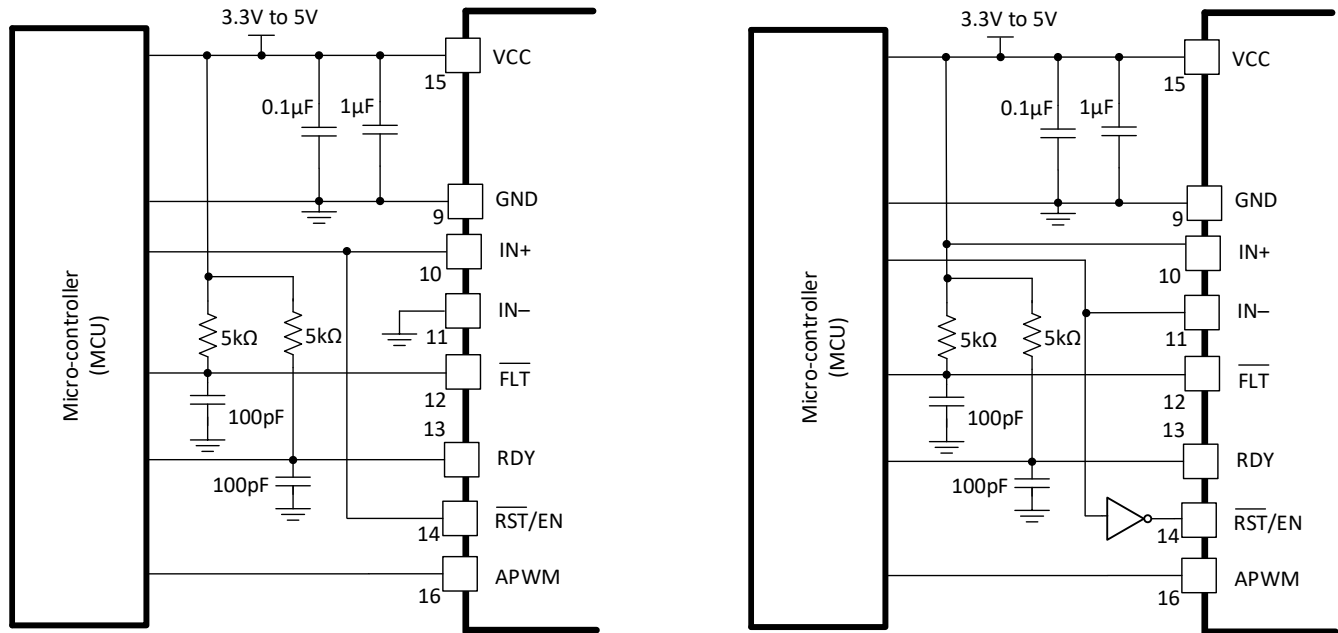

Figure 9-4. Automatic Reset Control

9.2.2.5 Turn on and turn off gate resistors

UCC21710 features split outputs OUTH and OUTL, which enables the independent control of the turn on and turn off switching speed. The turn on and turn off resistance determine the peak source and sink current, which controls the switching speed in turn. Meanwhile, the power dissipation in the gate driver should be considered to ensure the device is in the thermal limit. At first, the peak source and sink current are calculated as:

$$I_{\text{source_pk}} = \min\left(10\text{A}, \frac{\text{VDD} - \text{VEE}}{R_{\text{OH_EFF}} + R_{\text{ON}} + R_{\text{G_Int}}}\right)$$

$$I_{\text{sink_pk}} = \min\left(10\text{A}, \frac{\text{VDD} - \text{VEE}}{R_{\text{OL}} + R_{\text{OFF}} + R_{\text{G_Int}}}\right) \quad (1)$$

Where

- $R_{\text{OH_EFF}}$ is the effective internal pull up resistance of the hybrid pull-up structure, which is approximately $2 \times R_{\text{OL}}$, about 0.7Ω
- R_{OL} is the internal pulldown resistance, about 0.3Ω
- R_{ON} is the external turn on gate resistance
- R_{OFF} is the external turn off gate resistance
- $R_{\text{G_Int}}$ is the internal resistance of the SiC MOSFET or IGBT module

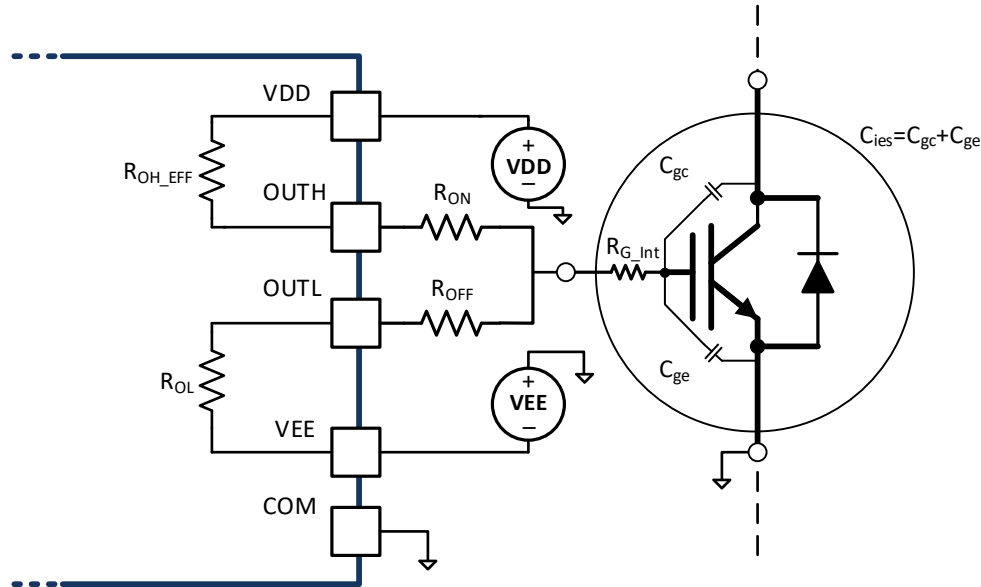

Figure 9-5. Output Model for Calculating Peak Gate Current

For example, for an IGBT module based system with the following parameters:

- $Q_g = 3300 \text{ nC}$
- $R_{G_Int} = 1.7 \Omega$
- $R_{ON}=R_{OFF}= 1 \Omega$

The peak source and sink current in this case are:

$$I_{\text{source_pk}} = \min\left(10\text{A}, \frac{V_{DD} - V_{EE}}{R_{OH_EFF} + R_{ON} + R_{G_Int}}\right) \approx 5.9\text{A}$$

$$I_{\text{sink_pk}} = \min\left(10\text{A}, \frac{V_{DD} - V_{EE}}{R_{OL} + R_{OFF} + R_{G_Int}}\right) \approx 6.7\text{A} \quad (2)$$

Thus by using 1Ω external gate resistance, the peak source current is 5.9A , the peak sink current is 6.7A . The collector-to-emitter dV/dt during the turn on switching transient is dominated by the gate current at the Miller plateau voltage. The hybrid pullup structure ensures the peak source current at the Miller plateau voltage, unless the turn on gate resistor is too high. The faster the collector-to-emitter, V_{ce} , voltage rises to V_{DC} , the smaller the turn on switching loss is. The dV/dt can be estimated as $Q_{gc}/I_{\text{source_pk}}$. For the turn off switching transient, the drain-to-source dV/dt is dominated by the load current, unless the turn off gate resistor is too high. After V_{ce} reaches the dc bus voltage, the power semiconductor is in saturation mode and the channel current is controlled by V_{ge} . The peak sink current determines the dI/dt , which dominates the V_{ce} voltage overshoot accordingly. If using relatively large turn off gate resistance, the V_{ce} overshoot can be limited. The overshoot can be estimated by:

$$\Delta V_{ce} = L_{\text{stray}} \cdot I_{\text{load}} / ((R_{OFF} + R_{OL} + R_{G_Int}) \cdot C_{ies} \cdot \ln(V_{\text{plat}} / V_{th})) \quad (3)$$

Where

- L_{stray} is the stray inductance in power switching loop, as shown in [Figure 9-6](#)
- I_{load} is the load current, which is the turn off current of the power semiconductor
- C_{ies} is the input capacitance of the power semiconductor
- V_{plat} is the plateau voltage of the power semiconductor
- V_{th} is the threshold voltage of the power semiconductor

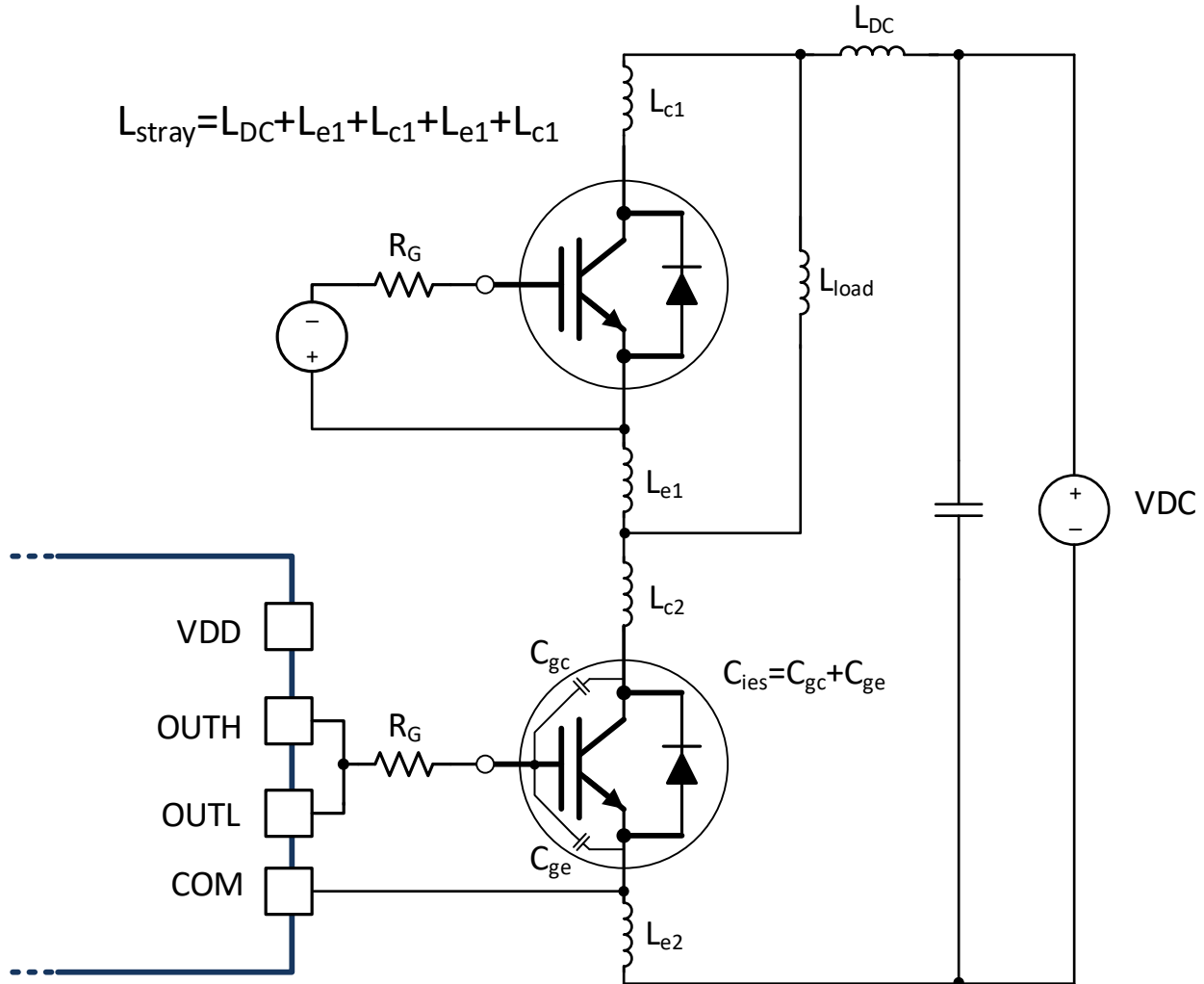

Figure 9-6. Stray Parasitic Inductance of IGBTs in a Half-Bridge Configuration

The power dissipation should be taken into account to maintain the gate driver within the thermal limit. The power loss of the gate driver includes the quiescent loss and the switching loss, which can be calculated as:

$$P_{DR} = P_Q + P_{SW} \tag{4}$$

P_Q is the quiescent power loss for the driver, which is $I_q \times (VDD - VEE) = 5\text{mA} \times 20\text{V} = 0.100\text{W}$. The quiescent power loss is the power consumed by the internal circuits such as the input stage, reference voltage, logic circuits, protection circuits when the driver is switching when the driver is biased with VDD and VEE, and also the charging and discharging current of the internal circuit when the driver is switching. The power dissipation when the driver is switching can be calculated as:

$$P_{SW} = \frac{1}{2} \cdot \left(\frac{R_{OH_EFF}}{R_{OH_EFF} + R_{ON} + R_{G_Int}} + \frac{R_{OL}}{R_{OL} + R_{OFF} + R_{G_Int}} \right) \cdot (VDD - VEE) \cdot f_{sw} \cdot Q_g \tag{5}$$

Where

- Q_g is the gate charge required at the operation point to fully charge the gate voltage from VEE to VDD
- f_{sw} is the switching frequency

In this example, the P_{SW} can be calculated as:

$$P_{SW} = \frac{1}{2} \cdot \left(\frac{R_{OH_EFF}}{R_{OH_EFF} + R_{ON} + R_{G_Int}} + \frac{R_{OL}}{R_{OL} + R_{OFF} + R_{G_Int}} \right) \cdot (VDD - VEE) \cdot f_{sw} \cdot Q_g = 0.505W \quad (6)$$

Thus, the total power loss is:

$$P_{DR} = P_Q + P_{SW} = 0.10W + 0.505W = 0.605W \quad (7)$$

When the board temperature is 125°C, the junction temperature can be estimated as:

$$T_j = T_b + \psi_{jb} \cdot P_{DR} \approx 150^\circ C \quad (8)$$

Therefore, for the application in this example, with 125°C board temperature, the maximum switching frequency is ~50kHz to keep the gate driver in the thermal limit. By using a lower switching frequency, or increasing external gate resistance, the gate driver can be operated at a higher switching frequency.

9.2.2.6 Overcurrent and Short Circuit Protection

Fast and reliable overcurrent and short circuit protection is important to protect the catastrophic break down of the SiC MOSFET and IGBT modules, and improve the system reliability. The UCC21710 features a state-of-art overcurrent and short circuit protection, which can be applied to both SiC MOSFET and IGBT modules with various detection circuits.

9.2.2.6.1 Protection Based on Power Modules with Integrated SenseFET

The overcurrent and short circuit protection function is suitable for the SiC MOSFET and IGBT modules with integrated SenseFET. The SenseFET scales down the main power loop current and outputs the current with a dedicated pin of the power module. With external high precision sensing resistor, the scaled down current can be measured and the main power loop current can be calculated. The value of the sensing resistor R_S sets the protection threshold of the main current. For example, with a ratio of 1:N = 1:50000 of the integrated current mirror, by using the R_S as 20Ω, the threshold protection current is:

$$I_{OC_TH} = \frac{V_{OCTH}}{R_S} \cdot N = 1750A \quad (9)$$

The overcurrent and short circuit protection based on integrated SenseFET has high precision, as it is sensing the current directly. The accuracy of the method is related to two factors: the scaling down ratio of the main power loop current and the SenseFET, and the precision of the sensing resistor. Since the current is sensed from the SenseFET, which is isolated from the main power loop, and the current is scaled down significantly with much less di/dt , the sensing loop has good noise immunity. To further improve the noise immunity, a low pass filter can be added. A 100pF to 10nF filter capacitor can be added. The delay time caused by the low pass filter should also be considered for the protection circuitry design.

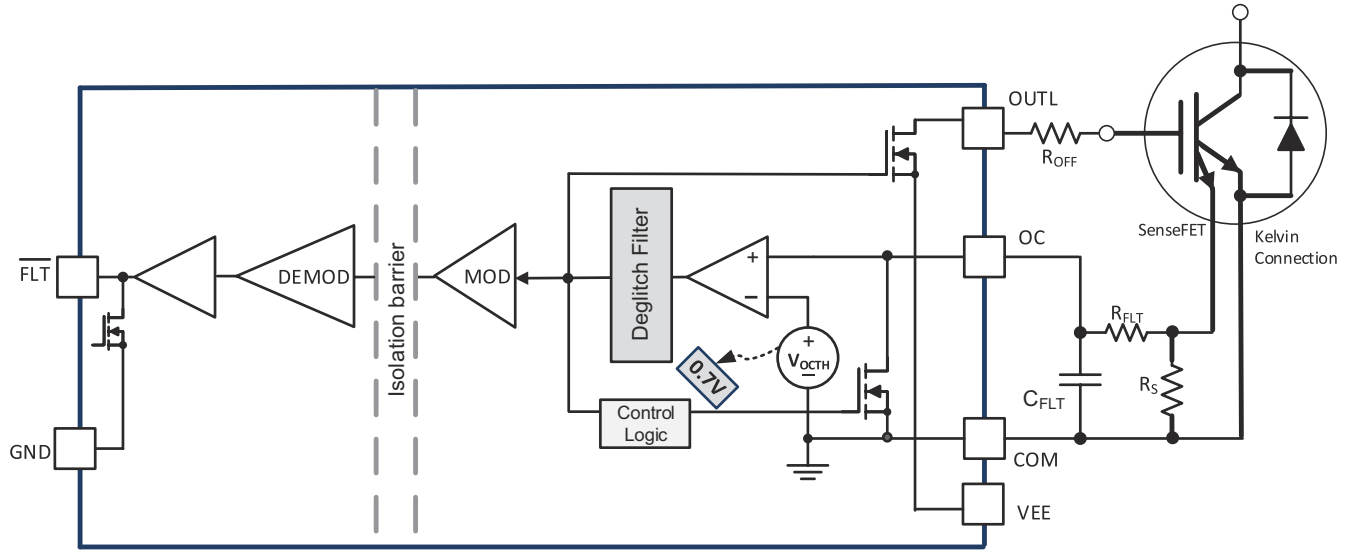

Figure 9-7. Overcurrent and Short Circuit Protection Based on IGBT Module with SenseFET

9.2.2.6.2 Protection Based on Desaturation Circuit

For SiC MOSFET and IGBT modules without SenseFET, desaturation (DESAT) circuit is the most popular circuit which is adopted for overcurrent and short circuit protection. The circuit consists of a current source, a resistor, a blanking capacitor and a diode. Normally the current source is provided from the gate driver, when the device turns on, a current source charges the blanking capacitor and the diode forward biased. During normal operation, the capacitor voltage is clamped by the switch V_{CE} voltage. When short circuit happens, the capacitor voltage is quickly charged to the threshold voltage which triggers the device shutdown. For the UCC21710, the OC pin does not feature an internal current source. The current source should be generated externally from the output power supply. When UCC21710 is in OFF state, the OC pin is pulled down by an internal MOSFET, which creates an offset voltage on OC pin. By choosing R_1 and R_2 significantly higher than the pulldown resistance of the internal MOSFET, the offset can be ignored. When UCC21710 is in ON state, the OC pin is high impedance. The current source is generated by the output power supply V_{DD} and the external resistor divider R_1 , R_2 and R_3 . The overcurrent detection threshold voltage of the IGBT is:

$$V_{DET} = V_{OCTH} \cdot \frac{R_2 + R_3}{R_3} - V_F \quad (10)$$

The blanking time of the detection circuit is:

$$t_{BLK} = -\frac{R_1 + R_2}{R_1 + R_2 + R_3} \cdot R_3 \cdot C_{BLK} \cdot \ln\left(1 - \frac{R_1 + R_2 + R_3}{R_3} \cdot \frac{V_{OCTH}}{V_{DD}}\right) \quad (11)$$

Where:

- V_{OCTH} is the detection threshold voltage of the gate driver
- R_1 , R_2 and R_3 are the resistance of the voltage divider
- C_{BLK} is the blanking capacitor
- V_F is the forward voltage of the high voltage diode D_{HV}

The modified desaturation circuit has all the benefits of the conventional desaturation circuit. The circuit has negligible power loss, and is easy to implement. The detection threshold voltage of IGBT and blanking time can be programmed by external components. Different with the conventional desaturation circuit, the overcurrent detection threshold voltage of the IGBT can be modified to any voltage level, either higher or lower than the detection threshold voltage of the driver. A parallel schottky diode can be connected between OC and COM pins to prevent the negative voltage on the OC pin in noisy system. Since the desaturation circuit measures the V_{CE}

of the IGBT or V_{DS} of the SiC MOSFET, not directly the current, the accuracy of the protection is not as high as the SenseFET based protection method. The current threshold cannot be accurately controlled in the protection.

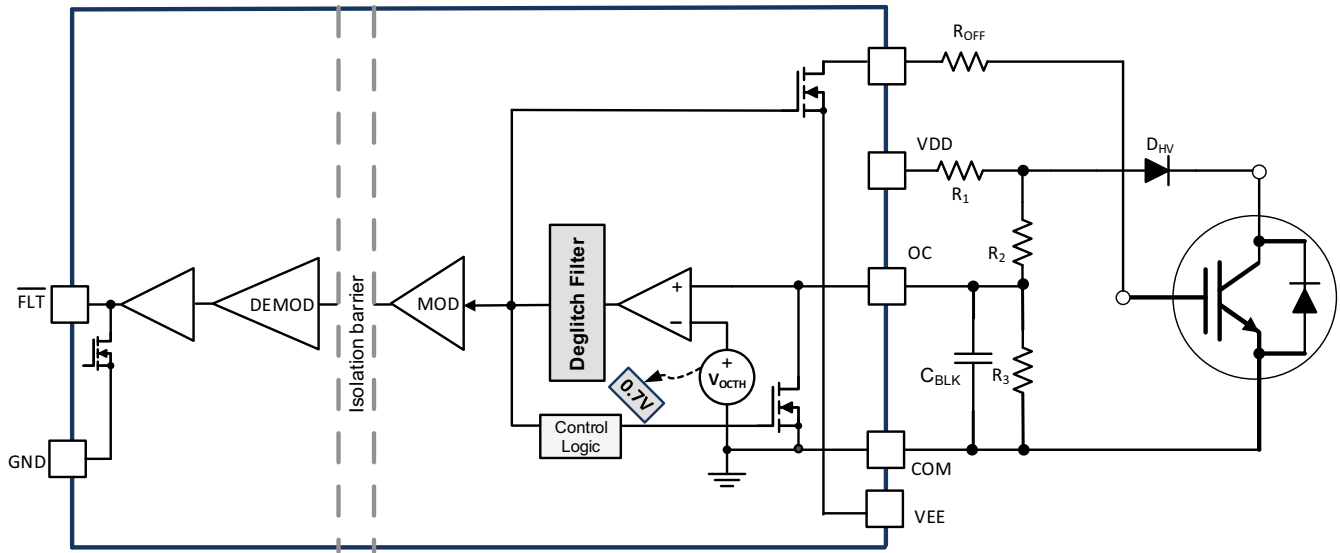

Figure 9-8. Overcurrent and Short Circuit Protection Based on Desaturation Circuit

9.2.2.6.3 Protection Based on Shunt Resistor in Power Loop

In lower power applications, to simplify the circuit and reduce the cost, a shunt resistor can be used in series in the power loop and measure the current directly. Since the resistor is in series in the power loop, it directly measures the current and can have high accuracy by using a high precision resistor. The resistance needs to be small to reduce the power loss, and should have large enough voltage resolution for the protection. Since the sensing resistor is also in series in the gate driver loop, the voltage drop on the sensing resistor can cause the voltage drop on the gate voltage of the IGBT or SiC MOSFET modules. The parasitic inductance of the sensing resistor and the PCB trace of the sensing loop will also cause a noise voltage source during switching transient, which makes the gate voltage oscillate. Thus, this method is not recommended for high power application, or when di/dt is high. To use it in low power application, the shunt resistor loop should be designed to have the optimal voltage drop and minimum noise injection to the gate loop.

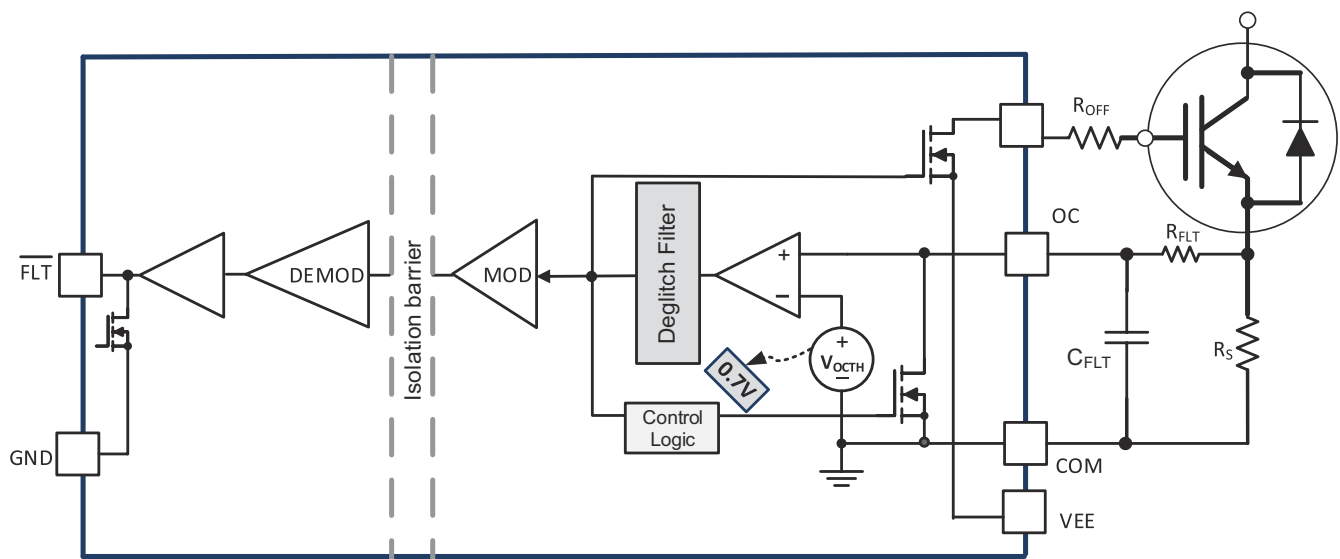

Figure 9-9. Overcurrent and Short Circuit Protection Based on Shunt Resistor

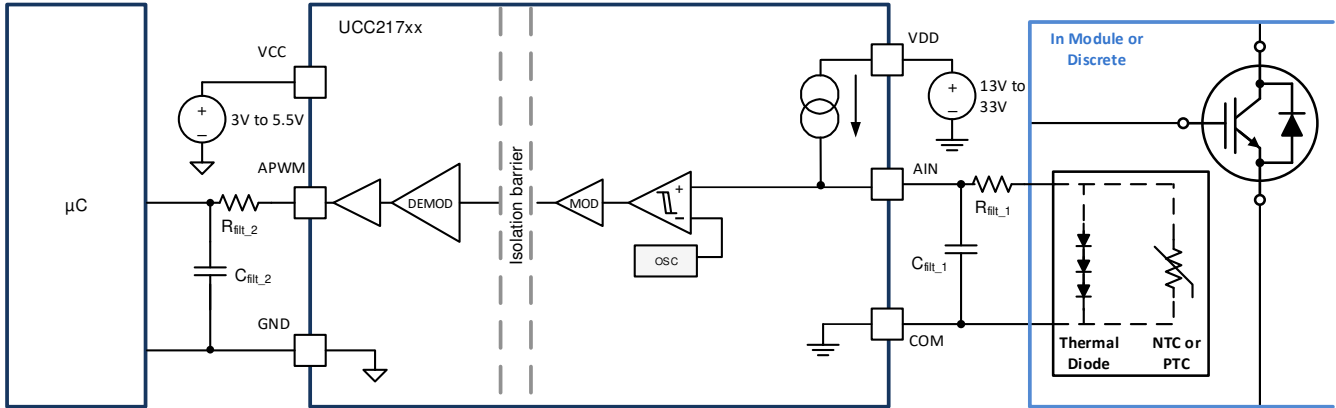

Figure 9-11. APWM Channel with Filtered Output

The example below shows the results using a 4.7kΩ NTC, NTCS0805E3472FMT, in series with a 3kΩ resistor and also the thermal diode using four diode-connected MMBT3904 NPN transistors. The sensed voltage of the 4 MMBT3904 thermal diodes connected in series ranges from about 2.5V to 1.6V from 25°C to 135°C, corresponding to 50% to 68% duty cycle. The sensed voltage of the NTC thermistor connected in series with the 3kΩ resistor ranges from about 1.5V to 0.6V from 25°C to 135°C, corresponding to 70% to 88% duty cycle. The voltage at VAIN of both sensors and the corresponding measured duty cycle at APWM is shown in Figure 9-12.

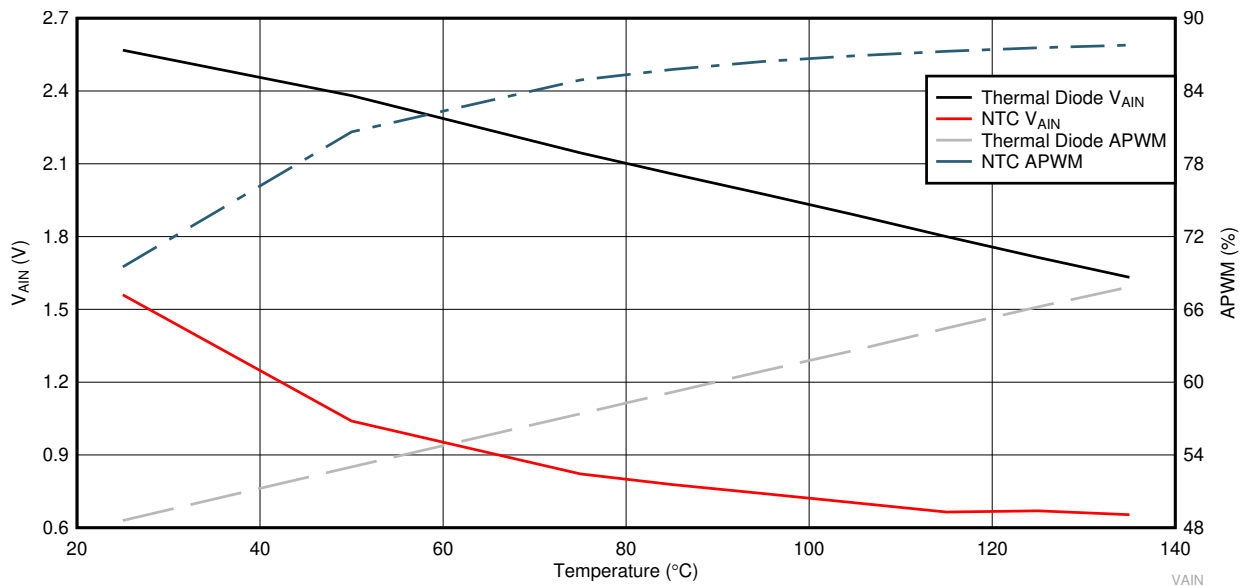

Figure 9-12. Thermal diode and NTC V_{AIN} and Corresponding Duty Cycle at APWM

The duty cycle output has an accuracy of $\pm 3\%$ throughout temperature without any calibration, as shown in Figure 9-13 but with single-point calibration at 25°C, the duty accuracy can be improved to $\pm 1\%$, as shown in Figure 9-14.

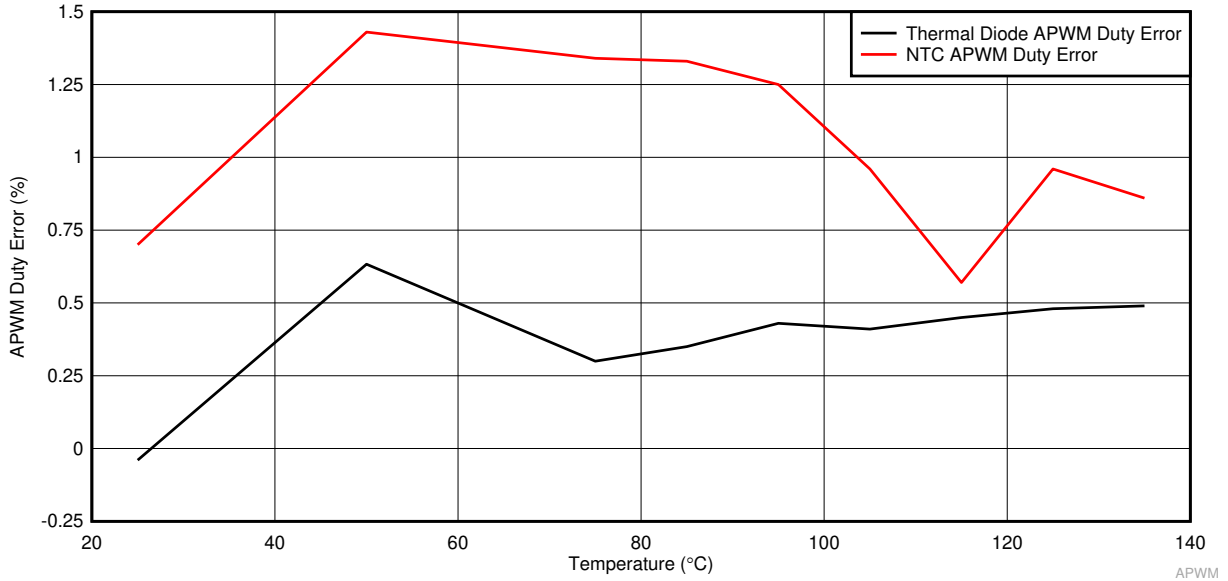

Figure 9-13. APWM Duty Error Without Calibration

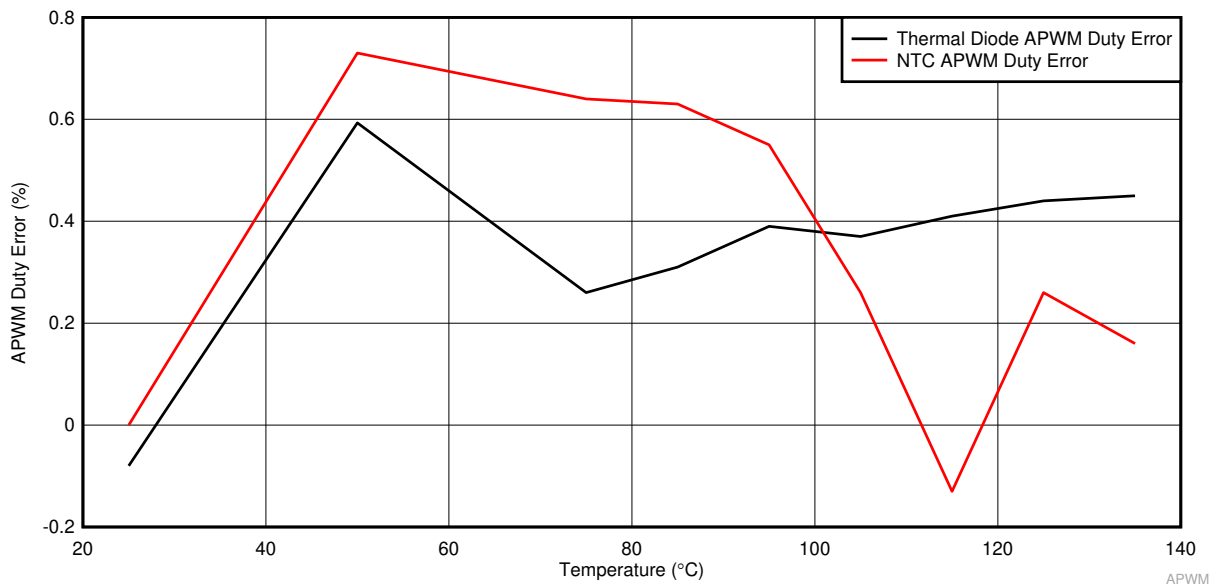

Figure 9-14. APWM Duty Error with Single-Point Calibration

9.2.2.7.2 Isolated DC Bus Voltage Sensing

The AIN to APWM channel may be used for other applications such as the DC-link voltage sensing, as shown in [Figure 9-15](#). The same filtering requirements as given above may be used in this case, as well. The number of attenuation resistors, R_{atten_1} through R_{atten_n} , is dependent on the voltage level and power rating of the resistor. The voltage is finally measured across R_{LV_DC} to monitor the stepped-down voltage of the HV DC-link which must fall within the voltage range of AIN from 0.6V to 4.5V. The driver should be referenced to the same point as the measurement reference, thus in the case shown below the UCC21710 is driving the lower IGBT in the half-bridge and the DC-link voltage measurement is referenced to COM. The internal current source I_{AIN} should be taken into account when designing the resistor divider. The AIN pin voltage is:

$$V_{AIN} = \frac{R_{LV_DC}}{R_{LV_DC} + \sum_{i=1}^n R_{atten_i}} \cdot V_{DC} + R_{LV_DC} \cdot I_{AIN} \quad (13)$$

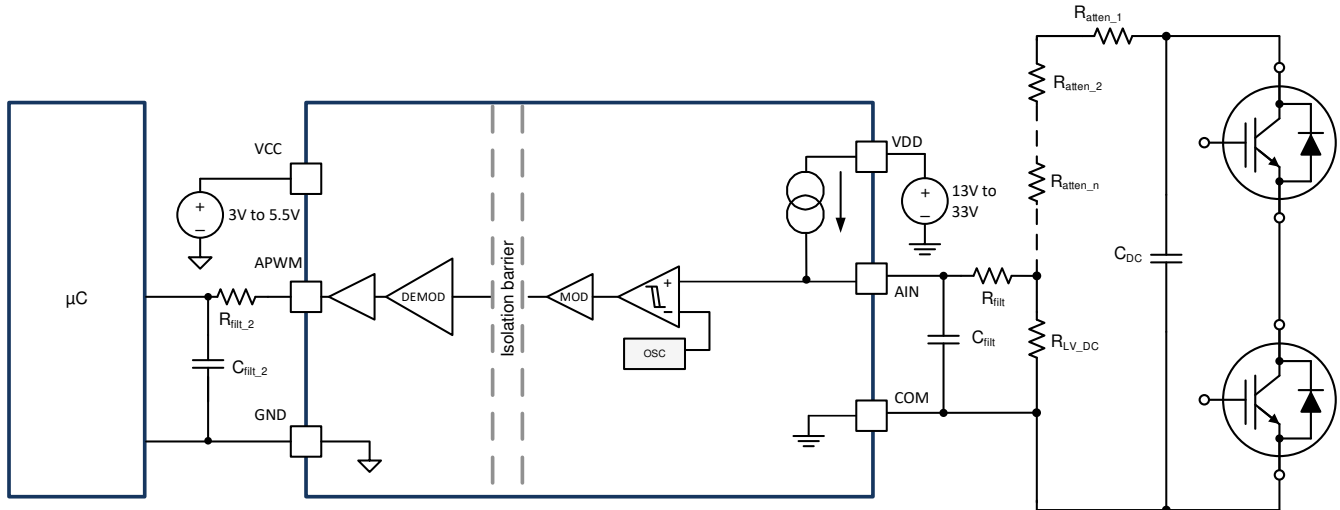

Figure 9-15. DC-link Voltage Sensing Configuration

9.2.2.8 Higher Output Current Using an External Current Buffer

To increase the IGBT gate drive current, a non-inverting current buffer (such as the NPN/PNP buffer shown in Figure 9-16) can be used. Inverting types are not compatible with the desaturation fault protection circuitry and must be avoided. The MJD44H11/MJD45H11 pair is appropriate for peak currents up to 15 A, the D44VH10/D45VH10 pair is up to 20 A peak.

In the case of a over-current detection, the soft turn off (STO) is activated. External components must be added to implement STO instead of normal turn off speed when an external buffer is used. C_{STO} sets the timing for soft turn off and R_{STO} limits the inrush current to below the current rating of the internal FET (10A). R_{STO} should be at least $(VDD-VEE)/10$. The soft turn off timing is determined by the internal current source of 400mA and the capacitor C_{STO} . C_{STO} is calculated using Equation 14.

$$C_{STO} = \frac{I_{STO} \cdot t_{STO}}{VDD - VEE} \quad (14)$$

- I_{STO} is the the internal STO current source, 400mA
- t_{STO} is the desired STO timing

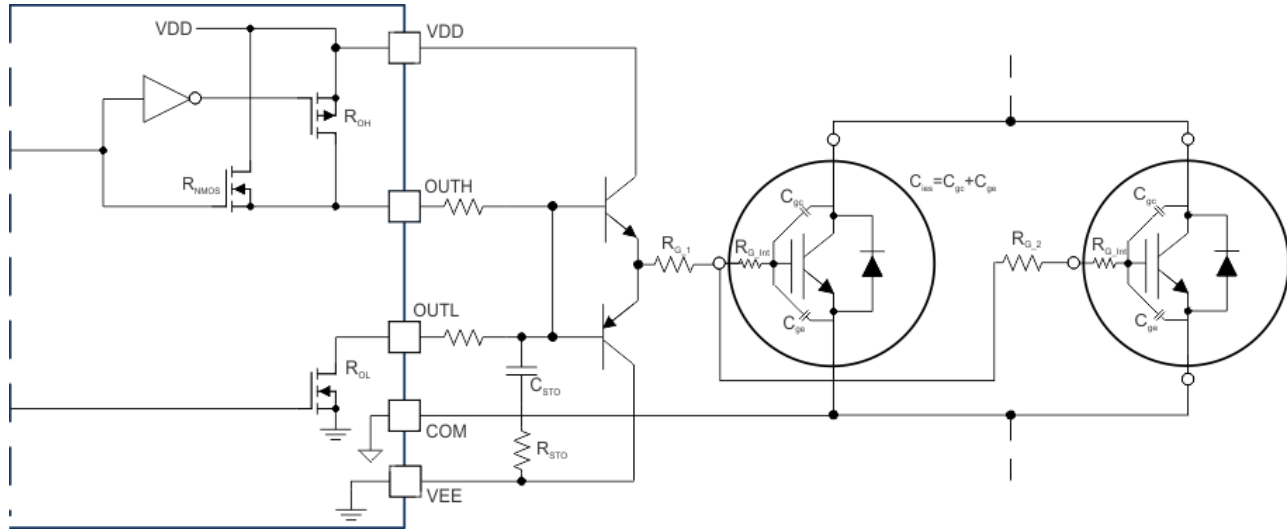

Figure 9-16. Current Buffer for Increased Drive Strength

10 Power Supply Recommendations

During the turn on and turn off switching transient, the peak source and sink current is provided by the VDD and VEE power supply. The large peak current is possible to drain the VDD and VEE voltage level and cause a voltage droop on the power supplies. To stabilize the power supply and ensure a reliable operation, a set of decoupling capacitors are recommended at the power supplies. Considering UCC21710 has $\pm 10\text{A}$ peak drive strength and can generate high dV/dt , a $10\mu\text{F}$ bypass cap is recommended between VDD and COM, VEE and COM. A $1\mu\text{F}$ bypass cap is recommended between VCC and GND due to less current comparing with output side power supplies. A $0.1\mu\text{F}$ decoupling cap is also recommended for each power supply to filter out high frequency noise. The decoupling capacitors must be low ESR and ESL to avoid high frequency noise, and should be placed as close as possible to the VCC, VDD and VEE pins to prevent noise coupling from the system parasitics of PCB layout.

11 Layout

11.1 Layout Guidelines

Due to the strong drive strength of UCC21710, careful considerations must be taken in PCB design. Below are some key points:

- The driver should be placed as close as possible to the power semiconductor to reduce the parasitic inductance of the gate loop on the PCB traces
- The decoupling capacitors of the input and output power supplies should be placed as close as possible to the power supply pins. The peak current generated at each switching transient can cause high di/dt and voltage spike on the parasitic inductance of PCB traces
- The driver COM pin should be connected to the Kelvin connection of SiC MOSFET source or IGBT emitter. If the power device does not have a split Kelvin source or emitter, the COM pin should be connected as close as possible to the source or emitter terminal of the power device package to separate the gate loop from the high power switching loop
- Use a ground plane on the input side to shield the input signals. The input signals can be distorted by the high frequency noise generated by the output side switching transients. The ground plane provides a low-inductance filter for the return current flow
- If the gate driver is used for the low side switch which the COM pin connected to the dc bus negative, use the ground plane on the output side to shield the output signals from the noise generated by the switch node; if the gate driver is used for the high side switch, which the COM pin is connected to the switch node, ground plane is not recommended
- If ground plane is not used on the output side, separate the return path of the OC and AIN ground loop from the gate loop ground which has large peak source and sink current
- No PCB trace or copper is allowed under the gate driver. A PCB cutout is recommended to avoid any noise coupling between the input and output side which can contaminate the isolation barrier

11.2 Layout Example

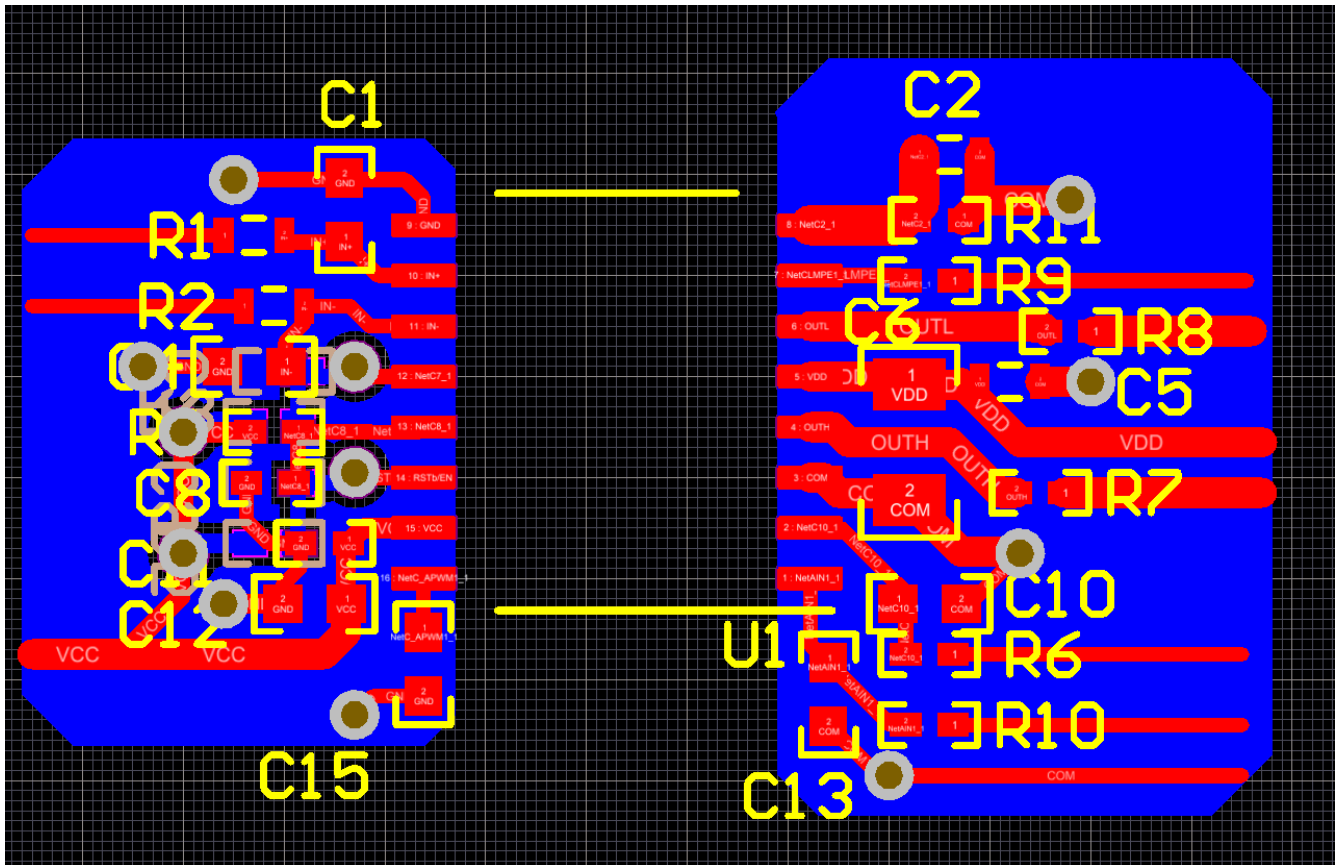

Figure 11-1. Layout Example

12 Device and Documentation Support

12.1 Device Support

12.1.1 Third-Party Products Disclaimer

TI'S PUBLICATION OF INFORMATION REGARDING THIRD-PARTY PRODUCTS OR SERVICES DOES NOT CONSTITUTE AN ENDORSEMENT REGARDING THE SUITABILITY OF SUCH PRODUCTS OR SERVICES OR A WARRANTY, REPRESENTATION OR ENDORSEMENT OF SUCH PRODUCTS OR SERVICES, EITHER ALONE OR IN COMBINATION WITH ANY TI PRODUCT OR SERVICE.

12.2 Documentation Support

12.2.1 Related Documentation

For related documentation see the following:

- [Isolation Glossary](#)

12.3 Receiving Notification of Documentation Updates

To receive notification of documentation updates, navigate to the device product folder on ti.com. In the upper right corner, click on *Alert me* to register and receive a weekly digest of any product information that has changed. For change details, review the revision history included in any revised document.

12.4 Support Resources

TI E2E™ [support forums](#) are an engineer's go-to source for fast, verified answers and design help — straight from the experts. Search existing answers or ask your own question to get the quick design help you need.

Linked content is provided "AS IS" by the respective contributors. They do not constitute TI specifications and do not necessarily reflect TI's views; see TI's [Terms of Use](#).

12.5 Trademarks

TI E2E™ is a trademark of Texas Instruments.

All trademarks are the property of their respective owners.

12.6 Electrostatic Discharge Caution



This integrated circuit can be damaged by ESD. Texas Instruments recommends that all integrated circuits be handled with appropriate precautions. Failure to observe proper handling and installation procedures can cause damage.

ESD damage can range from subtle performance degradation to complete device failure. Precision integrated circuits may be more susceptible to damage because very small parametric changes could cause the device not to meet its published specifications.

12.7 Glossary

[TI Glossary](#) This glossary lists and explains terms, acronyms, and definitions.

13 Mechanical, Packaging, and Orderable Information

The following pages include mechanical packaging and orderable information. This information is the most current data available for the designated devices. This data is subject to change without notice and revision of this document. For browser-based versions of this data sheet, refer to the left-hand navigation.

PACKAGING INFORMATION

Orderable Device	Status (1)	Package Type	Package Drawing	Pins	Package Qty	Eco Plan (2)	Lead finish/ Ball material (6)	MSL Peak Temp (3)	Op Temp (°C)	Device Marking (4/5)	Samples
UCC21710DW	LIFEBUY	SOIC	DW	16	40	RoHS & Green	NIPDAU	Level-2-260C-1 YEAR	-40 to 125	UCC21710	
UCC21710DWR	ACTIVE	SOIC	DW	16	2000	RoHS & Green	NIPDAU	Level-2-260C-1 YEAR	-40 to 125	UCC21710	Samples

(1) The marketing status values are defined as follows:

ACTIVE: Product device recommended for new designs.

LIFEBUY: TI has announced that the device will be discontinued, and a lifetime-buy period is in effect.

NRND: Not recommended for new designs. Device is in production to support existing customers, but TI does not recommend using this part in a new design.

PREVIEW: Device has been announced but is not in production. Samples may or may not be available.

OBSOLETE: TI has discontinued the production of the device.

(2) **RoHS:** TI defines "RoHS" to mean semiconductor products that are compliant with the current EU RoHS requirements for all 10 RoHS substances, including the requirement that RoHS substance do not exceed 0.1% by weight in homogeneous materials. Where designed to be soldered at high temperatures, "RoHS" products are suitable for use in specified lead-free processes. TI may reference these types of products as "Pb-Free".

RoHS Exempt: TI defines "RoHS Exempt" to mean products that contain lead but are compliant with EU RoHS pursuant to a specific EU RoHS exemption.

Green: TI defines "Green" to mean the content of Chlorine (Cl) and Bromine (Br) based flame retardants meet JS709B low halogen requirements of <=1000ppm threshold. Antimony trioxide based flame retardants must also meet the <=1000ppm threshold requirement.

(3) MSL, Peak Temp. - The Moisture Sensitivity Level rating according to the JEDEC industry standard classifications, and peak solder temperature.

(4) There may be additional marking, which relates to the logo, the lot trace code information, or the environmental category on the device.

(5) Multiple Device Markings will be inside parentheses. Only one Device Marking contained in parentheses and separated by a "~" will appear on a device. If a line is indented then it is a continuation of the previous line and the two combined represent the entire Device Marking for that device.

(6) Lead finish/Ball material - Orderable Devices may have multiple material finish options. Finish options are separated by a vertical ruled line. Lead finish/Ball material values may wrap to two lines if the finish value exceeds the maximum column width.

Important Information and Disclaimer: The information provided on this page represents TI's knowledge and belief as of the date that it is provided. TI bases its knowledge and belief on information provided by third parties, and makes no representation or warranty as to the accuracy of such information. Efforts are underway to better integrate information from third parties. TI has taken and continues to take reasonable steps to provide representative and accurate information but may not have conducted destructive testing or chemical analysis on incoming materials and chemicals. TI and TI suppliers consider certain information to be proprietary, and thus CAS numbers and other limited information may not be available for release.

In no event shall TI's liability arising out of such information exceed the total purchase price of the TI part(s) at issue in this document sold by TI to Customer on an annual basis.

OTHER QUALIFIED VERSIONS OF UCC21710 :

- Automotive : [UCC21710-Q1](#)

NOTE: Qualified Version Definitions:

- Automotive - Q100 devices qualified for high-reliability automotive applications targeting zero defects

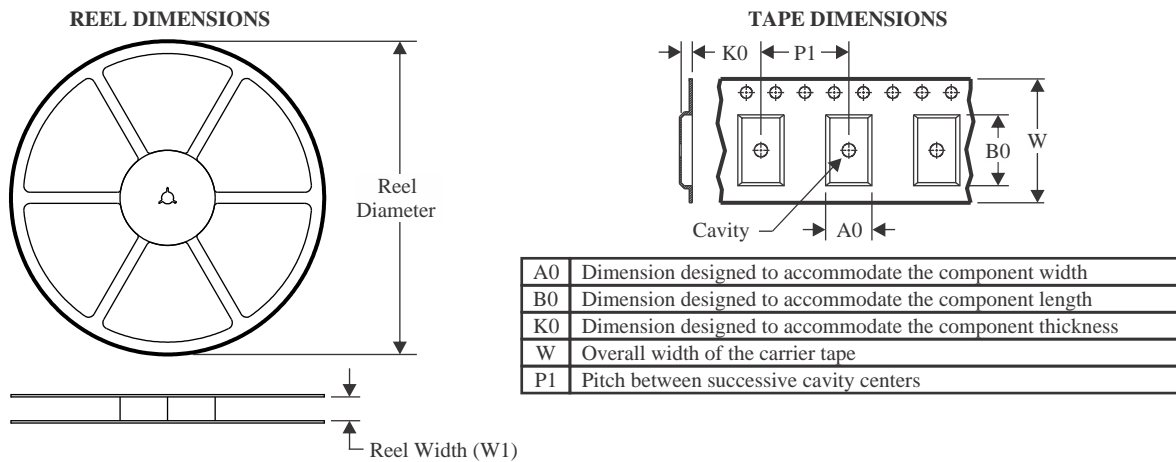
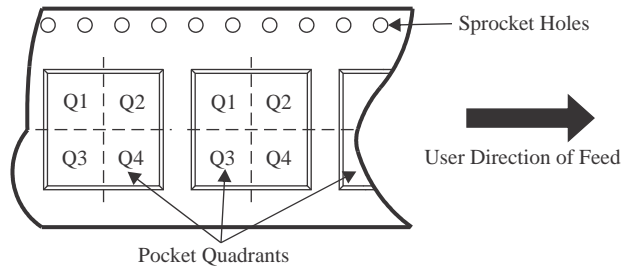
TAPE AND REEL INFORMATION

QUADRANT ASSIGNMENTS FOR PIN 1 ORIENTATION IN TAPE

*All dimensions are nominal

Device	Package Type	Package Drawing	Pins	SPQ	Reel Diameter (mm)	Reel Width W1 (mm)	A0 (mm)	B0 (mm)	K0 (mm)	P1 (mm)	W (mm)	Pin1 Quadrant
UCC21710DWR	SOIC	DW	16	2000	330.0	16.4	10.75	10.7	2.7	12.0	16.0	Q1

TAPE AND REEL BOX DIMENSIONS

*All dimensions are nominal

Device	Package Type	Package Drawing	Pins	SPQ	Length (mm)	Width (mm)	Height (mm)
UCC21710DWR	SOIC	DW	16	2000	356.0	356.0	35.0

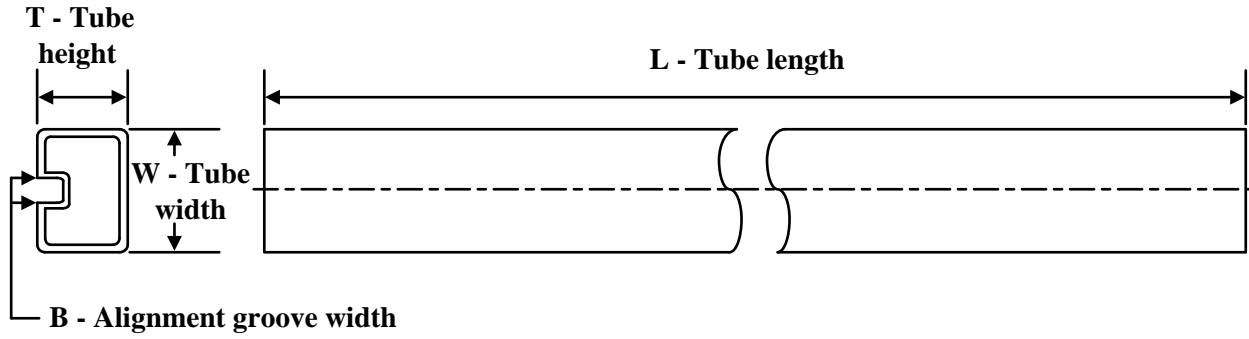
TUBE

*All dimensions are nominal

Device	Package Name	Package Type	Pins	SPQ	L (mm)	W (mm)	T (μm)	B (mm)
UCC21710DW	DW	SOIC	16	40	506.98	12.7	4826	6.6

GENERIC PACKAGE VIEW

DW 16

SOIC - 2.65 mm max height

7.5 x 10.3, 1.27 mm pitch

SMALL OUTLINE INTEGRATED CIRCUIT

This image is a representation of the package family, actual package may vary.
Refer to the product data sheet for package details.

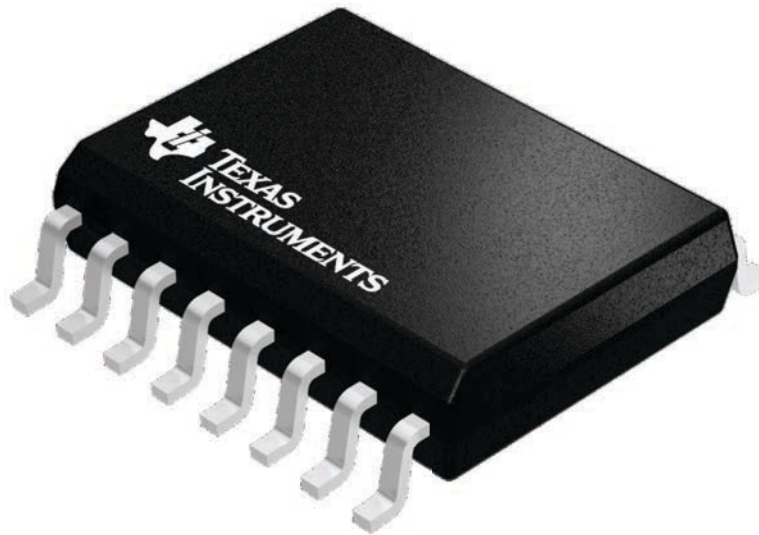

4224780/A

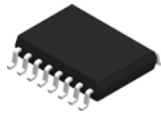

DW0016B

PACKAGE OUTLINE

SOIC - 2.65 mm max height

SOIC

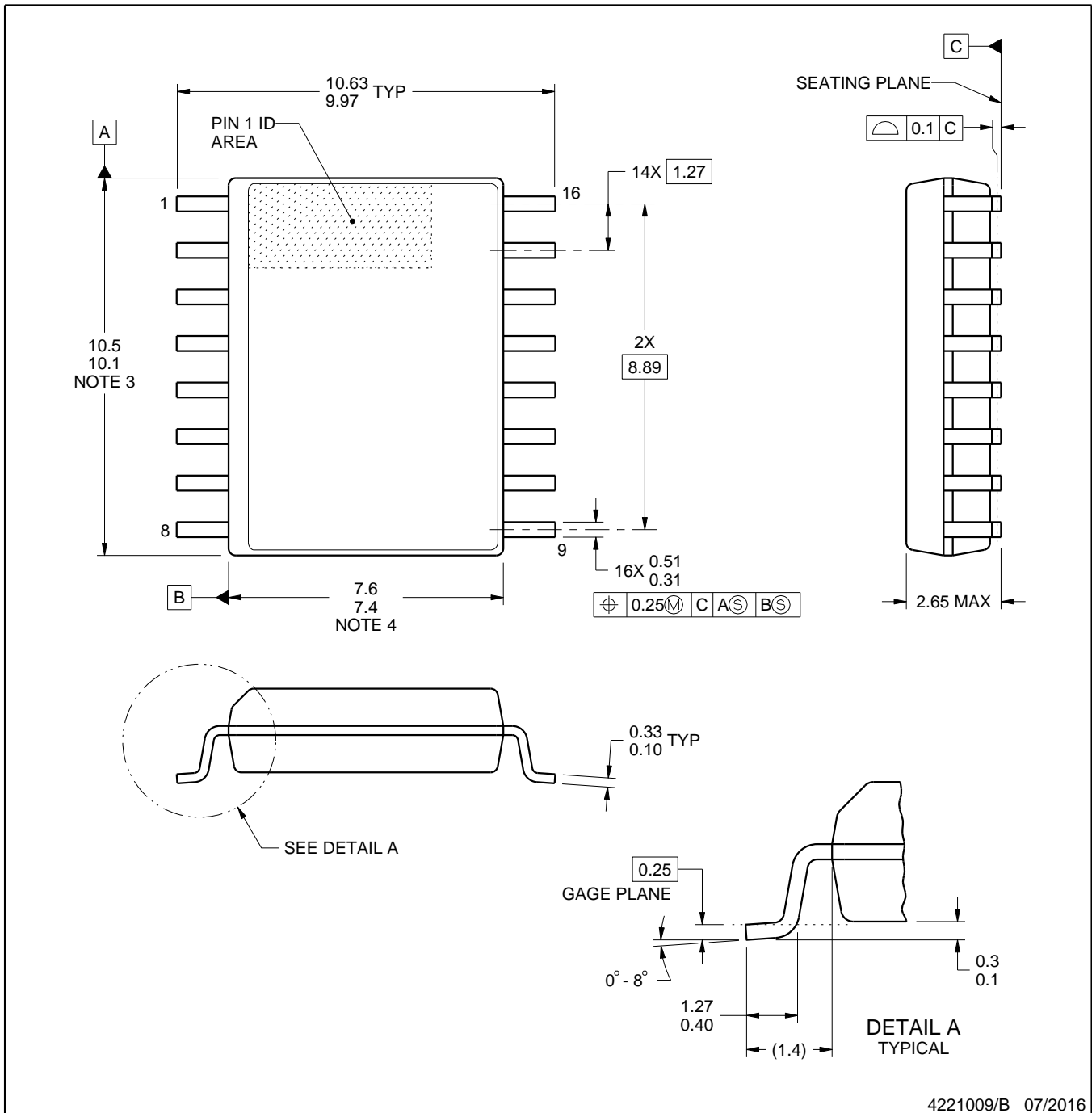

4221009/B 07/2016

NOTES:

1. All linear dimensions are in millimeters. Dimensions in parenthesis are for reference only. Dimensioning and tolerancing per ASME Y14.5M.
2. This drawing is subject to change without notice.
3. This dimension does not include mold flash, protrusions, or gate burrs. Mold flash, protrusions, or gate burrs shall not exceed 0.15 mm, per side.
4. This dimension does not include interlead flash. Interlead flash shall not exceed 0.25 mm, per side.
5. Reference JEDEC registration MS-013.

EXAMPLE BOARD LAYOUT

DW0016B

SOIC - 2.65 mm max height

SOIC

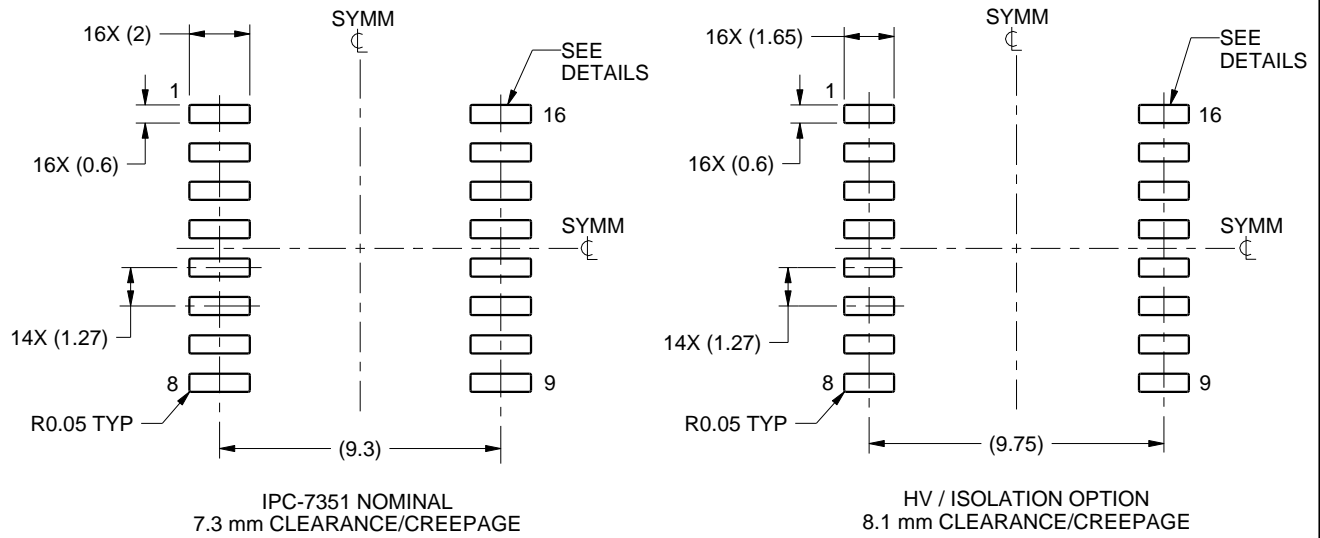

LAND PATTERN EXAMPLE
SCALE:4X

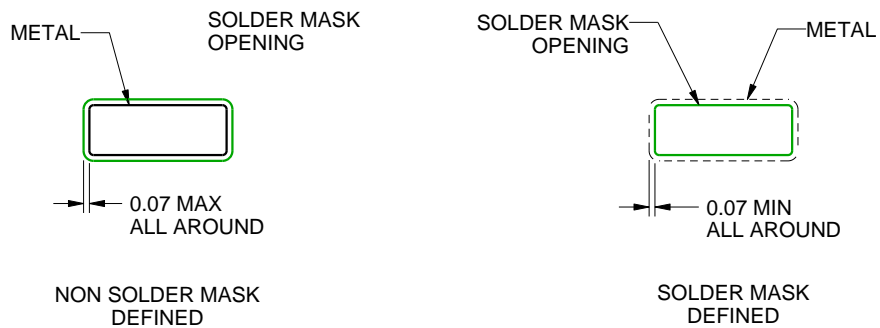

SOLDER MASK DETAILS

4221009/B 07/2016

NOTES: (continued)

- 6. Publication IPC-7351 may have alternate designs.
- 7. Solder mask tolerances between and around signal pads can vary based on board fabrication site.

EXAMPLE STENCIL DESIGN

DW0016B

SOIC - 2.65 mm max height

SOIC

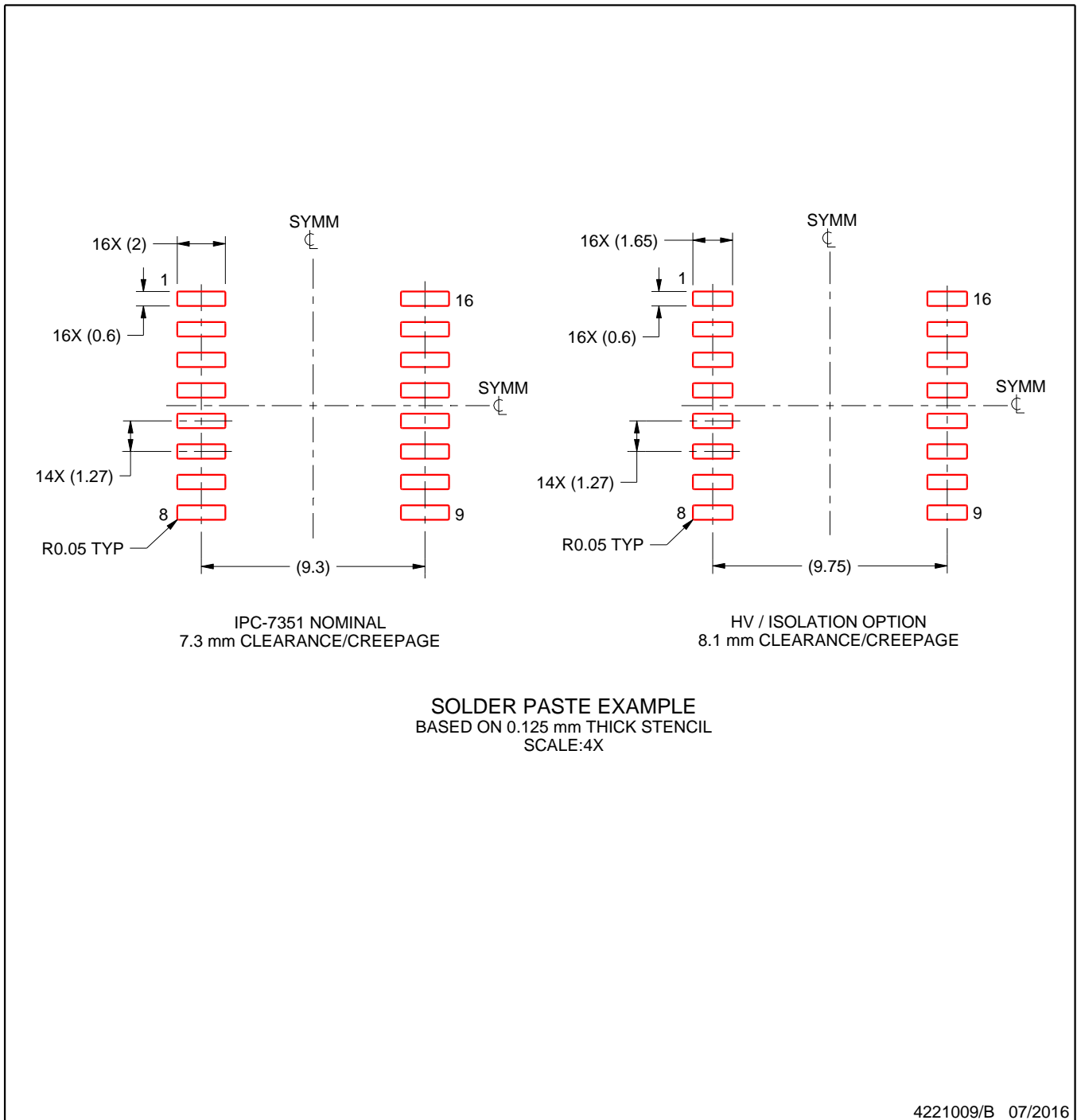

NOTES: (continued)

8. Laser cutting apertures with trapezoidal walls and rounded corners may offer better paste release. IPC-7525 may have alternate design recommendations.
9. Board assembly site may have different recommendations for stencil design.

IMPORTANT NOTICE AND DISCLAIMER

TI PROVIDES TECHNICAL AND RELIABILITY DATA (INCLUDING DATA SHEETS), DESIGN RESOURCES (INCLUDING REFERENCE DESIGNS), APPLICATION OR OTHER DESIGN ADVICE, WEB TOOLS, SAFETY INFORMATION, AND OTHER RESOURCES "AS IS" AND WITH ALL FAULTS, AND DISCLAIMS ALL WARRANTIES, EXPRESS AND IMPLIED, INCLUDING WITHOUT LIMITATION ANY IMPLIED WARRANTIES OF MERCHANTABILITY, FITNESS FOR A PARTICULAR PURPOSE OR NON-INFRINGEMENT OF THIRD PARTY INTELLECTUAL PROPERTY RIGHTS.

These resources are intended for skilled developers designing with TI products. You are solely responsible for (1) selecting the appropriate TI products for your application, (2) designing, validating and testing your application, and (3) ensuring your application meets applicable standards, and any other safety, security, regulatory or other requirements.

These resources are subject to change without notice. TI grants you permission to use these resources only for development of an application that uses the TI products described in the resource. Other reproduction and display of these resources is prohibited. No license is granted to any other TI intellectual property right or to any third party intellectual property right. TI disclaims responsibility for, and you will fully indemnify TI and its representatives against, any claims, damages, costs, losses, and liabilities arising out of your use of these resources.

TI's products are provided subject to [TI's Terms of Sale](#) or other applicable terms available either on [ti.com](https://www.ti.com) or provided in conjunction with such TI products. TI's provision of these resources does not expand or otherwise alter TI's applicable warranties or warranty disclaimers for TI products.

TI objects to and rejects any additional or different terms you may have proposed.

Mailing Address: Texas Instruments, Post Office Box 655303, Dallas, Texas 75265
Copyright © 2024, Texas Instruments Incorporated

Looking for pricing, stock, or lifecycle information?

Click below to explore more details on WIN SOURCE:

 [View UCC21710DW](#) on WIN SOURCE

 [Texas Instruments](#) Information

Optimize Your Supply Chain with WIN SOURCE Solutions

-  Global Sourcing Solution
-  Obsolete Management
-  Cost Control Management
-  Shortage Management
-  Alternative Solution
-  Excess Inventory Management