



THE DATASHEET OF ISO1640BDR



ISO164x Hot-Swappable Bidirectional I²C Isolators with Enhanced EMC and GPIOs

1 Features

- Robust Isolated Bidirectional, I²C Compatible, Communication
 - ISO1640: Bidirectional SDA and SCL communication
 - ISO1641: Bidirectional SDA and unidirectional SCL communication
 - ISO1642/3/4: Bidirectional SDA and SCL communication with either 2 or 3 unidirectional GPIO channels
 - Hot-Swappable SDA and SCL
- Bidirectional data transfer up to 1.7 MHz Operation
- Up to 3 additional unidirectional isolated GPIO channels supporting 50 Mbps speed
- Robust isolation barrier with enhanced EMC:
 - >100-year projected lifetime at 450 V_{RMS} working voltage (D-8) and 1500 V_{RMS} working voltage (DW-16)
 - Up to 5000 V_{RMS} isolation rating per UL1577
 - Up to 10 kV reinforced surge capability
 - ±100 kV/μs typical CMTI
 - ±8 kV IEC-ESD 61000-4-2 contact discharge protection across isolation barrier
 - Same side ±8 kV IEC-ESD unpowered contact discharge on SCL2 and SDA2 (Side 2)
- Supply range: 3 V to 5.5 V (Side 1) and 2.25 V to 5.5 V (Side 2)
- Open-drain outputs with 3.5-mA (Side 1) and 50-mA (Side 2) current-sink capability
- Max capacitive load: 80 pF (Side 1) and 400 pF (Side 2)
- 16-SOIC (DW-16) and 8-SOIC (D-8) Package Options
- –40°C to +125°C Operating Temperature
- Safety-Related Certifications (planned):
 - UL 1577 Component Recognition Program
 - DIN VDE V 0884-11
 - IEC 62368-1, IEC 61010-1, IEC 60601-1 and GB4943.1-2011 certifications

2 Applications

- Isolated I²C Buses
- Isolated I²C and SPI Buses
- SMBus and PMBus Interfaces
- Power Over Ethernet (PoE)
- Motor Control Systems
- Battery Management

3 Description

The ISO1640, ISO1641, ISO1642, ISO1643 and ISO1644 (ISO164x) devices are hot swappable, low-power, bidirectional isolators that are compatible with I²C interfaces. The ISO164x supports UL 1577 isolation ratings of 5000 V_{RMS} in the 16-DW package, and 3000 V_{RMS} in the 8-D package. Each I²C isolation channel in this low emissions device has a logic input and open drain output separated by a double capacitive silicon dioxide (SiO₂) insulation barrier. The ISO1642 and ISO1643 integrates 2 unidirectional CMOS isolation channels, while the ISO1644 integrates 3 unidirectional CMOS isolation channels which can be used for static GPIO isolation or to isolate a Serial Peripheral Interface (SPI) bus. This family includes basic and reinforced insulation devices certified by VDE, UL, CSA, TUV and CQC. The ISO1640/2/3/4 have two isolated bidirectional channels for clock and data lines and the ISO1641 has a bidirectional data and a unidirectional clock channel. The ISO164x family integrates logic required to support bidirectional channels, providing a much simpler design and smaller footprint when compared to optocoupler-based solutions.

Device Information⁽¹⁾

PART NUMBER	PACKAGE	BODY SIZE (NOM)
ISO1640BD ISO1641BD	SOIC (8)	4.90 mm × 3.91 mm
ISO1640DW ISO1641DW ISO1642DW ISO1643DW ISO1644DW	SOIC (16)	10.30 mm × 7.50 mm

(1) For all available packages, see the orderable addendum at the end of the data sheet.

Isolation Options

PART NUMBER	ISO164xBD	ISO164xDW
Protection Level	Basic	Reinforced
Surge Test Voltage	6500 V _{PK}	10000 V _{PK}
Isolation Rating	3000 V _{RMS}	5000 V _{RMS}
Working Voltage	450 V _{RMS} / 637 V _{PK}	1500 V _{RMS} / 2121 V _{PK}



Table of Contents

1 Features	1	8.1 Overview.....	30
2 Applications	1	8.2 Functional Block Diagrams.....	30
3 Description	1	8.3 Isolation Technology Overview.....	31
4 Revision History	2	8.4 Feature Description.....	31
5 Pin Configuration and Functions	3	8.5 Isolator Functional Principle.....	32
6 Specifications	8	8.6 Device Functional Modes.....	34
6.1 Absolute Maximum Ratings	8	9 Application and Implementation	35
6.2 ESD Ratings	8	9.1 Application Information.....	35
6.3 Recommended Operating Conditions	8	9.2 Typical Application.....	36
6.4 Thermal Information	9	9.3 <i>Insulation Lifetime</i>	42
6.5 Power Ratings	10	10 Power Supply Recommendations	44
6.6 Insulation Specifications	11	11 Layout	45
6.7 Safety-Related Certifications	13	11.1 Layout Guidelines.....	45
6.8 Safety Limiting Values	13	11.2 Layout Example.....	45
6.9 Electrical Characteristics	14	12 Device and Documentation Support	46
6.10 Supply Current Characteristics	15	12.1 Documentation Support.....	46
6.11 Timing Requirements	18	12.2 Receiving Notification of Documentation Updates.....	46
6.12 I2C Switching Characteristics	19	12.3 Support Resources.....	46
6.13 GPIO Switching Characteristics	21	12.4 Trademarks.....	46
6.14 Insulation Characteristics Curves.....	22	12.5 Electrostatic Discharge Caution.....	46
6.15 Typical Characteristics.....	23	12.6 Glossary.....	46
7 Parameter Measurement Information	27	13 Mechanical, Packaging, and Orderable Information	46
7.1 Parameter Measurement Information.....	27		
8 Detailed Description	30		

4 Revision History

NOTE: Page numbers for previous revisions may differ from page numbers in the current version.

Changes from Revision C (June 2021) to Revision D (September 2021)	Page
• Added ISO1641DW, ISO1642DW and ISO1643DW to the datasheet.....	1

Changes from Revision B (May 2021) to Revision C (June 2021)	Page
• Added ISO1644DW to the datasheet.....	1

Changes from Revision A (December 2020) to Revision B (May 2021)	Page
• Added ISO1641B to the datasheet.....	1
• Changed minimum input threshold low to 480 mV.....	14
• Changed t_{pLH1-2} , t_{pLH2-1} , t_{LOOP1} max to a lower value for all operating voltages.....	19

5 Pin Configuration and Functions

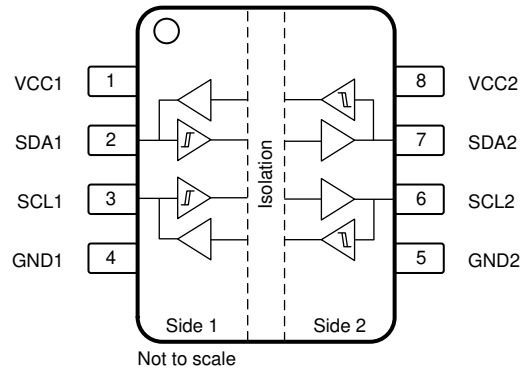

Figure 5-1. ISO1640B Package 8-Pin SOIC Top View

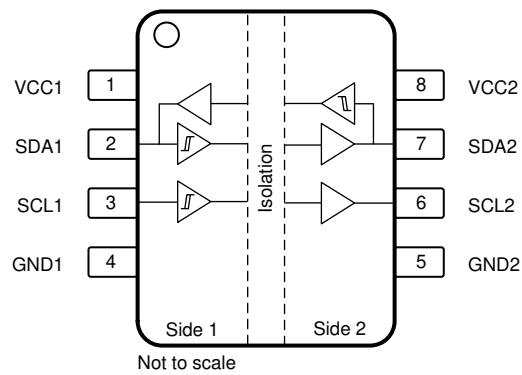

Figure 5-2. ISO1641B Package 8-Pin SOIC Top View

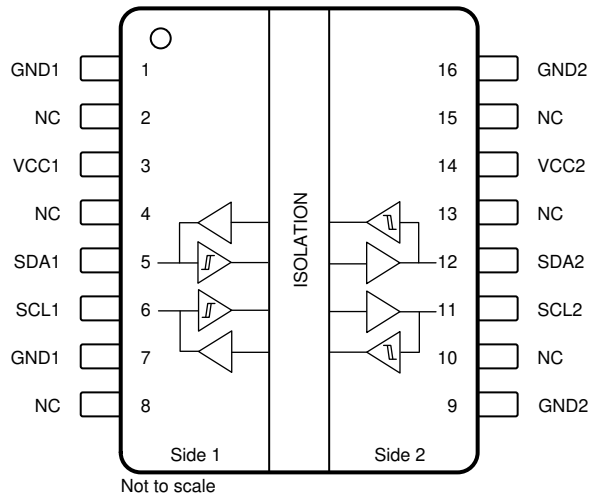

Figure 5-3. ISO1640 Package 16-Pin SOIC Top View

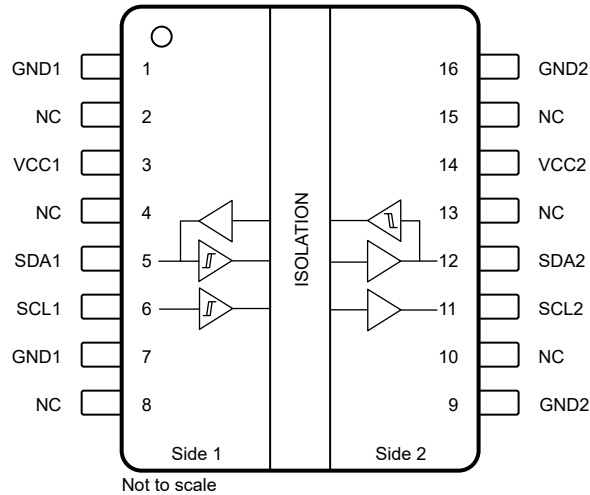

Figure 5-4. ISO1641 Package 16-Pin SOIC Top View

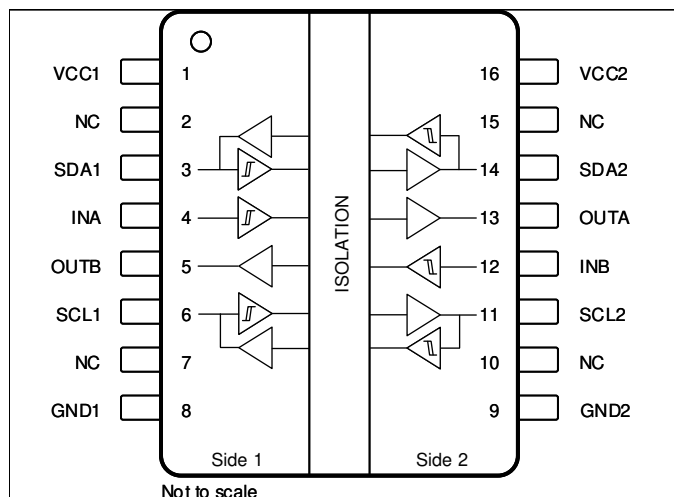

Figure 5-5. ISO1642 Package 16-Pin SOIC Top View

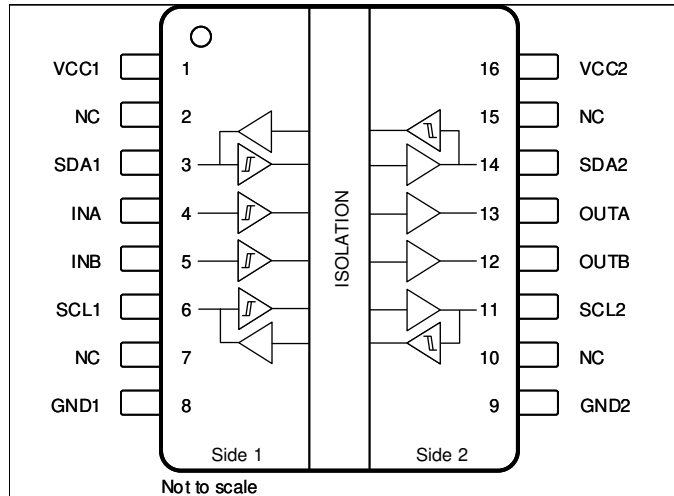

Figure 5-6. ISO1643 Package 16-Pin SOIC Top View

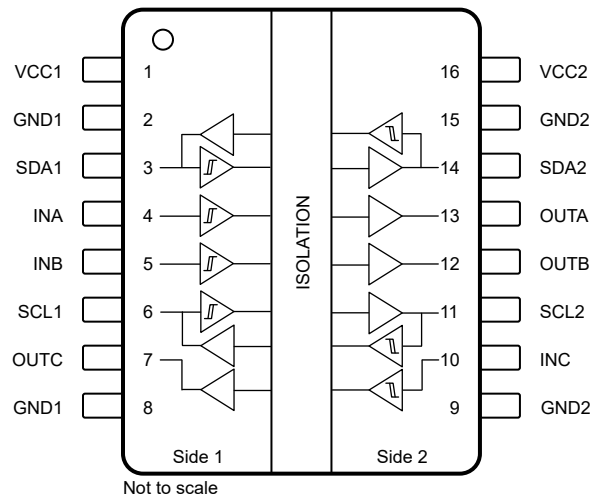

Figure 5-7. ISO1644 Package 16-Pin SOIC Top View

Table 5-1. Pin Functions — ISO1640 and ISO1641

PIN			I/O	DESCRIPTION
NAME	8-D NO.	16-DW NO.		
GND1	4	1, 7	—	Ground, side 1
GND2	5	9, 16	—	Ground, side 2
NC	—	2, 4, 8, 10, 13, 15	—	No Connection
SCL1	3	6	I/O	Serial clock input / output, side 1 (ISO1640 only) Serial clock input, side 1 (ISO1641 only)
SCL2	6	11	I/O	Serial clock input / output, side 2 (ISO1640 only) Serial clock output, side 2 (ISO1641 only)
SDA1	2	5	I/O	Serial data input / output, side 1
SDA2	7	12	I/O	Serial data input / output, side 2
VCC1	1	3	—	Supply voltage, side 1
VCC2	8	14	—	Supply voltage, side 2

Table 5-2. Pin Functions — ISO1642 and ISO1643

PIN		I/O	DESCRIPTION
NAME	16-DW NO.		
GND1	8	—	Ground, side 1
GND2	9	—	Ground, side 2
INA	4	I	Input, channel A
INB/OUTB	12	—	Input, channel B (ISO1642) Output, channel B (ISO1643)
NC	2, 7, 10, 15	—	No Connect
OUTA	13	O	Output, channel A
OUTB/INB	5	—	Output, channel B (ISO1642) Input, channel B (ISO1643)
SCL1	6	I/O	Serial clock input / output, side 1
SCL2	11	I/O	Serial clock input / output, side 2
SDA1	3	I/O	Serial data input / output, side 1
SDA2	14	I/O	Serial data input / output, side 2
VCC1	1	—	Supply voltage, side 1
VCC2	16	—	Supply voltage, side 2

Table 5-3. Pin Functions — ISO1644

PIN		I/O	DESCRIPTION
NAME	16-DW NO.		
GND1	2, 8	—	Ground, side 1
GND2	9, 15	—	Ground, side 2
INA	4	I	Input, channel A
INB	5	I	Input, channel B
INC	10	I	Input, channel C
OUTA	13	O	Output, channel A
OUTB	12	O	Output, channel B
OUTC	7	O	Output, channel C

Table 5-3. Pin Functions — ISO1644 (continued)

PIN		I/O	DESCRIPTION
NAME	16-DW NO.		
SCL1	6	I/O	Serial clock input / output, side 1
SCL2	11	I/O	Serial clock input / output, side 2
SDA1	3	I/O	Serial data input / output, side 1
SDA2	14	I/O	Serial data input / output, side 2
VCC1	1	—	Supply voltage, side 1
VCC2	16	—	Supply voltage, side 2

6 Specifications

6.1 Absolute Maximum Ratings

over operating free-air temperature range (unless otherwise noted)^{(1) (2)}

		MIN	MAX	UNIT
Supply Voltage	V _{CC1} , V _{CC2}	-0.5	6	V
Input/Output Voltage	SDA1, SCL1	-0.5	V _{CCX} + 0.5 ⁽³⁾	V
	SDA2, SCL2	-0.5	V _{CCX} + 0.5 ⁽³⁾	
	INx (ISO1642/3/4 only)	-0.5	V _{CCX} + 0.5	
Input/Output Current	SDA1, SCL1	0	20	mA
	SDA2, SCL2	0	100	
	I _O (ISO1642/3/4 only)	-15	15	
Temperature	Maximum junction temperature, T _J		150	°C
	Storage temperature, T _{stg}	-65	150	°C

- Stresses beyond those listed under *Absolute Maximum Ratings* may cause permanent damage to the device. These are stress ratings only, which do not imply functional operation of the device at these or any other conditions beyond those indicated under *Recommended Operating Conditions*. Exposure to absolute-maximum-rated conditions for extended periods may affect device reliability.
- All voltage values are with respect to the local ground pin (GND1 or GND2) and are peak voltage values.
- During powered off hotswap, the I²C bus pins can be 0 V < SDAx, SCLx < 6 V.

6.2 ESD Ratings

			VALUE	UNIT	
V _(ESD)	Electrostatic discharge	Human body model (HBM), per ANSI/ESDA/JEDEC JS-001 ⁽¹⁾	All pins	±6000	V
			ISO1640/1: Bus pins (SDA1, SCL1)	±10000	V
			ISO1640/1: Bus pins (SDA2, SCL2)	±14000	V
			ISO1642/3/4: Bus pins (SDA1, SCL1)	±8000	V
			ISO1642/3/4: Bus pins (SDA2, SCL2)	±8000	V
		Charged-device model (CDM), per ANSI/ESDA/JEDEC specification JS-002 ⁽²⁾	±1500	V	
		Contact discharge per IEC 61000-4-2; Isolation barrier withstand test ^{(3) (4)}	±8000	V	
		Same side unpowered IEC ESD contact discharge per IEC 61000-4-2; Side 2	ISO1640/1: SCL2, SDA2	±8000	V

- JEDEC document JEP155 states that 500-V HBM allows safe manufacturing with a standard ESD control process.
- JEDEC document JEP157 states that 250-V CDM allows safe manufacturing with a standard ESD control process.
- IEC ESD strike is applied across the barrier with all pins on each side tied together creating a two-terminal device.
- Testing is carried out in air or oil to determine the intrinsic contact discharge capability of the device.

6.3 Recommended Operating Conditions

		MIN	NOM	MAX	UNIT
V _{CC1(UVLO+)}	UVLO threshold when supply voltage is rising on Side 1		2.7	2.9	V
V _{CC1(UVLO-)}	UVLO threshold when supply voltage is falling on Side 1	2.3	2.6		V
V _{CC2(UVLO+)}	UVLO threshold when supply voltage is rising on Side 2		2	2.25	V
V _{CC2(UVLO-)}	UVLO threshold when supply voltage is falling on Side 2	1.7	1.8		V
V _{HYS1(UVLO)}	Supply voltage UVLO hysteresis, Side 1	100	150		mV
V _{HYS2(UVLO)}	Supply voltage UVLO hysteresis, Side 2	100	150		mV
V _{CC1}	Supply voltage, Side 1	3.0		5.5	V
V _{CC2}	Supply voltage, Side 2	2.25		5.5	V
V _{SDA1} , V _{SCL1}	I ² C Input and output signal voltages, Side 1	0		V _{CC1}	V

		MIN	NOM	MAX	UNIT
V_{SDA2} , V_{SCL2}	I2C Input and output signal voltages, Side 2	0		V_{CC2}	V
V_{IL1}	I2C Low-level input voltage, Side 1	0		480	mV
V_{IH1}	I2C High-level input voltage, Side 1	$0.7 \times V_{CC1}$		V_{CC1}	V
V_{IL2}	I2C Low-level input voltage, Side 2	0		$0.3 \times V_{CC2}$	V
V_{IH2}	I2C High-level input voltage, Side 2	$0.5 \times V_{CC2}$		V_{CC2}	V
I_{OL1}	I2C Output current, Side 1	0.5		3.5	mA
I_{OL2}	I2C Output current, Side 2	0.5		50	mA
C1	Capacitive load, Side 1			80	pF
C2	Capacitive load, Side 2			400	pF
f_{MAX}	I2C Operating frequency ⁽¹⁾			1.7	MHz
V_{LHIO}	Low-level input voltage, GPIO pins (ISO1642/3/4 only)	0		$0.3 \times V_{CC2}$	V
V_{HHIO}	High-level input voltage, GPIO pins (ISO1642/3/4 only)	$0.7 \times V_{CC1}$		V_{CC1}	V
I_{OHIO}	GPIO High-level output current, $V_{CCO} = 5$ V (ISO1642/3/4 only)	-4			mA
	GPIO High-level output current, $V_{CCO} = 3.3$ V (ISO1642/3/4 only)	-2			mA
	GPIO High-level output current, $V_{CCO} = 2.5$ V (ISO1642/3/4 only)	-1			mA
I_{OLIO}	GPIO Low-level output current, $V_{CCO} = 5$ V (ISO1642/3/4 only)			4	mA
	GPIO Low-level output current, $V_{CCO} = 3.3$ V (ISO1642/3/4 only)			2	mA
	GPIO Low-level output current, $V_{CCO} = 2.5$ V (ISO1642/3/4 only)			1	mA
f_{DR}	GPIO maximum data rate frequency (ISO1642/3/4 only)			50	Mbps
T_A	Ambient temperature	-40	25	125	°C

(1) Maximum frequency is a function of the RC time constant on the bus. If the system has less bus capacitance, then higher frequencies can be achieved.

6.4 Thermal Information

THERMAL METRIC ⁽¹⁾		ISO1640/1		ISO1642/3/4	UNIT
		D (SOIC)	DW (SOIC)	DW (SOIC)	
		8 PINS	16 PINS	16 PINS	
$R_{\theta JA}$	Junction-to-ambient thermal resistance	106.3	62.4	58.3	°C/W
$R_{\theta JC(top)}$	Junction-to-case (top) thermal resistance	38.5	29.5	25.5	°C/W
$R_{\theta JB}$	Junction-to-board thermal resistance	52.5	33.5	29.7	°C/W
ψ_{JT}	Junction-to-top characterization parameter	8.2	11.7	8.9	°C/W
ψ_{JB}	Junction-to-board characterization parameter	51.8	32.4	28.5	°C/W
$R_{\theta JC(bot)}$	Junction-to-case (bottom) thermal resistance	-	-	-	°C/W

(1) For more information about traditional and new thermal metrics, see the [Semiconductor and IC Package Thermal Metrics application report](#).

6.5 Power Ratings

PARAMETER		TEST CONDITIONS	MIN	TYP	MAX	UNIT
ISO1640						
P_D	Maximum power dissipation (both sides)	$V_{CC1} = V_{CC2} = 5.5\text{ V}$, $T_J = 150^\circ\text{C}$, $C1 = 20\text{ pF}$, $C2 = 400\text{ pF}$, $R1 = 1.4\text{ k}\Omega$, $R2 = 94\ \Omega$, Input a 1.7-MHz 50% duty-cycle clock signal			96	mW
P_{D1}	Maximum power dissipation (side-1)				43	mW
P_{D2}	Maximum power dissipation (side-2)				53	mW
ISO1641						
P_D	Maximum power dissipation (both sides)	$V_{CC1} = V_{CC2} = 5.5\text{ V}$, $T_J = 150^\circ\text{C}$, $C1 = 20\text{ pF}$, $C2 = 400\text{ pF}$, $R1 = 1.4\text{ k}\Omega$, $R2 = 94\ \Omega$, Input a 1.7-MHz 50% duty-cycle clock signal			87	mW
P_{D1}	Maximum power dissipation (side-1)	$V_{CC1} = V_{CC2} = 5.5\text{ V}$, $T_J = 150^\circ\text{C}$, $C1 = 20\text{ pF}$, $C2 = 400\text{ pF}$, $R1 = 1.4\text{ k}\Omega$, $R2 = 94\ \Omega$, Input a 1.7-MHz 50% duty-cycle clock signal			40	mW
P_{D2}	Maximum power dissipation (side-2)	$V_{CC1} = V_{CC2} = 5.5\text{ V}$, $T_J = 150^\circ\text{C}$, $C1 = 20\text{ pF}$, $C2 = 400\text{ pF}$, $R1 = 1.4\text{ k}\Omega$, $R2 = 94\ \Omega$, Input a 1.7-MHz 50% duty-cycle clock signal			47	mW
ISO1642						
P_D	Maximum power dissipation (both sides)	$V_{CC1} = V_{CC2} = 5.5\text{ V}$, $T_J = 150^\circ\text{C}$, $C1 = 20\text{ pF}$, $C2 = 400\text{ pF}$, $R1 = 1.4\text{ k}\Omega$, $R2 = 94\ \Omega$, Input a 1.7-MHz 50% duty-cycle clock signal INA = INB = Input at 25-MHz 50% duty cycle square wave, CL = 15pF			185	mW
P_{D1}	Maximum power dissipation (side-1)				83	mW
P_{D2}	Maximum power dissipation (side-2)				102	mW
ISO1643						
P_D	Maximum power dissipation (both sides)	$V_{CC1} = V_{CC2} = 5.5\text{ V}$, $T_J = 150^\circ\text{C}$, $C1 = 20\text{ pF}$, $C2 = 400\text{ pF}$, $R1 = 1.4\text{ k}\Omega$, $R2 = 94\ \Omega$, Input a 1.7-MHz 50% duty-cycle clock signal INA = INB = Input at 25-MHz 50% duty cycle square wave, CL = 15pF			185	mW
P_{D1}	Maximum power dissipation (side-1)				67	mW
P_{D2}	Maximum power dissipation (side-2)				118	mW
ISO1644						
P_D	Maximum power dissipation (both sides)	$V_{CC1} = V_{CC2} = 5.5\text{ V}$, $T_J = 150^\circ\text{C}$, $C1 = 20\text{ pF}$, $C2 = 400\text{ pF}$, $R1 = 1.4\text{ k}\Omega$, $R2 = 94\ \Omega$, Input a 1.7-MHz 50% duty-cycle clock signal INA = INB = INC = Input at 25-MHz 50% duty cycle square wave, CL = 15pF			210	mW
P_{D1}	Maximum power dissipation (side-1)				88	mW
P_{D2}	Maximum power dissipation (side-2)				122	mW

6.6 Insulation Specifications

PARAMETER		TEST CONDITIONS	SPECIFICATIONS		UNIT
			DW	D	
IEC 60664-1					
CLR	External clearance ⁽¹⁾	Side 1 to side 2 distance through air	>8	4	mm
CPG	External Creepage ⁽¹⁾	Side 1 to side 2 distance across package surface	>8	4	mm
DTI	Distance through the insulation	Minimum internal gap (internal clearance)	>17	>17	µm
CTI	Comparative tracking index	IEC 60112; UL 746A	>600	>400	V
	Material Group	According to IEC 60664-1	I	II	
	Overvoltage category	Rated mains voltage ≤ 150 V _{RMS}	I-IV	I-IV	
		Rated mains voltage ≤ 300 V _{RMS}	I-IV	I-III	
		Rated mains voltage ≤ 600 V _{RMS}	I-IV	n/a	
		Rated mains voltage ≤ 1000 V _{RMS}	I-III	n/a	
DIN V VDE V 0884-11:2017-01⁽²⁾					
V _{IORM}	Maximum repetitive peak isolation voltage	AC voltage (bipolar)	2121	637	V _{PK}
V _{IOWM}	Maximum isolation working voltage	AC voltage (sine wave); time-dependent dielectric breakdown (TDDb) test;	1500	450	V _{RMS}
		DC voltage	2121	637	V _{DC}
V _{IOTM}	Maximum transient isolation voltage	V _{TEST} = V _{IOTM} , t = 60 s (qualification); V _{TEST} = 1.2 × V _{IOTM} , t = 1 s (100% production)	7071	4242	V _{PK}
V _{IOSM}	Maximum surge isolation voltage ⁽³⁾	Test method per IEC 62368-1, 1.2/50 µs waveform, V _{TEST} = 1.3 × V _{IOSM} = 6,500 V _{PK} (Basic qualification) Test method per IEC 62368-1, 1.2/50 µs waveform, V _{TEST} = 1.6 × V _{IOSM} = 10,000 V _{PK} (Reinforced qualification)	6250	5000	V _{PK}
q _{pd}	Apparent charge ⁽⁴⁾	Method a: After I/O safety test subgroup 2/3, V _{ini} = V _{IOTM} , t _{ini} = 60 s; V _{pd(m)} = 1.2 × V _{IORM} , t _m = 10 s	≤ 5	≤ 5	pC
		Method a: After environmental tests subgroup 1, V _{ini} = V _{IOTM} , t _{ini} = 60 s; V _{pd(m)} = 1.6 × V _{IORM} , t _m = 10 s	≤ 5	≤ 5	
		Method b1: At routine test (100% production) and preconditioning (type test), V _{ini} = V _{IOTM} , t _{ini} = 1 s; V _{pd(m)} = 1.875 × V _{IORM} , t _m = 1 s	≤ 5	≤ 5	
C _{IO}	Barrier capacitance, input to output ⁽⁵⁾	V _{IO} = 0.4 × sin (2 πft), f = 1 MHz	1	1	pF
R _{IO}	Insulation resistance, input to output ⁽⁵⁾	V _{IO} = 500 V, T _A = 25°C	> 10 ¹²	> 10 ¹²	Ω
		V _{IO} = 500 V, 100°C ≤ T _A ≤ 150°C	> 10 ¹¹	> 10 ¹¹	
		V _{IO} = 500 V at T _S = 150°C	> 10 ⁹	> 10 ⁹	
	Pollution degree		2	2	
	Climatic category		40/125/21	40/125/21	
UL 1577					
V _{ISO}	Withstand isolation voltage	V _{TEST} = V _{ISO} , t = 60 s (qualification); V _{TEST} = 1.2 × V _{ISO} , t = 1 s (100% production)	5000	3000	V _{RMS}

- (1) Creepage and clearance requirements should be applied according to the specific equipment isolation standards of an application. Care should be taken to maintain the creepage and clearance distance of a board design to ensure that the mounting pads of the isolator on the printed-circuit board do not reduce this distance. Creepage and clearance on a printed-circuit board become equal in certain cases. Techniques such as inserting grooves, ribs, or both on a printed circuit board are used to help increase these specifications.
- (2) ISO164xDW is suitable for *safe electrical insulation* and ISO164xBD is suitable for *basic electrical insulation* only within the safety ratings. Compliance with the safety ratings shall be ensured by means of suitable protective circuits.
- (3) Testing is carried out in air or oil to determine the intrinsic surge immunity of the isolation barrier.

- (4) Apparent charge is electrical discharge caused by a partial discharge (pd).
- (5) All pins on each side of the barrier tied together creating a two-pin device.

6.7 Safety-Related Certifications

VDE	CSA	UL	CQC	TUV
Certified according to DIN VDE V 0884-11:2017-01	Certified according to IEC 61010-1, IEC 62368-1 and IEC 60601-1	Recognized under UL 1577 Component Recognition Program	Certified according to GB4943.1-2011	Certified according to EN 61010-1:2010/A1:2019, and EN 62368-1:2014
Maximum transient isolation voltage, 7071 V _{PK} (DW-16), and 4242 V _{PK} (D-8); Maximum repetitive peak isolation voltage, 1500 V _{PK} (DW-16), and 637 V _{PK} (D-8); Maximum surge isolation voltage, 6250 V _{PK} (DW-16), and 5000 V _{PK} (D-8)	DW-16: 600 V _{RMS} reinforced insulation per CSA 62368-1:19 and IEC 62368-1:2018, (pollution degree 2, material group I) D-8: 400 V _{RMS} basic insulation per CSA 62368-1:19 and IEC 62368-1:2018, (pollution degree 2, material group III)	DW-16: Single protection, 5000 V _{RMS} ; D-8: Single protection, 3000 V _{RMS}	DW-16: Reinforced Insulation, Altitude ≤ 5000 m, Tropical Climate, 700 V _{RMS} maximum working voltage; D-8: Basic Insulation, Altitude ≤ 5000 m, Tropical Climate, 250 V _{RMS} maximum working voltage	5000 V _{RMS} (DW-16) and 3000 V _{RMS} (D-8) Reinforced insulation per EN 61010-1:2010/A1:2019 up to working voltage of 600 V _{RMS} (DW-16) and 300 V _{RMS} (D-8) 5000 V _{RMS} (DW-16) and 3000 V _{RMS} (D-8) Reinforced insulation per EN 62368-1:2014 up to working voltage of 600 V _{RMS} (DW-16) and 400 V _{RMS} (D-8)
Certification planned	Master contract number (ISO164xBD): 220991 Certification planned (All others)	File number (ISO164xBD): E181974 Certification planned (All others)	Certification planned	Certification planned

6.8 Safety Limiting Values

Safety limiting intends to minimize potential damage to the isolation barrier upon failure of input or output circuitry.

PARAMETER		TEST CONDITIONS	MIN	TYP	MAX	UNIT
ISO1640/1 D-8 PACKAGE						
I _S	Safety input, output, or supply current ⁽¹⁾	R _{θJA} = 106.3 °C/W, V _I = 5.5 V, T _J = 150°C, T _A = 25°C			214	mA
		R _{θJA} = 106.3 °C/W, V _I = 3.6 V, T _J = 150°C, T _A = 25°C			327	
P _S	Safety input, output, or total power ⁽¹⁾	R _{θJA} = 106.3 °C/W, T _J = 150°C, T _A = 25°C			1176	mW
T _S	Safety temperature ⁽¹⁾				150	°C
ISO1640/1 DW-16 PACKAGE						
I _S	Safety input, output, or supply current ⁽¹⁾	R _{θJA} = 62.4 °C/W, V _I = 5.5 V, T _J = 150°C, T _A = 25°C			365	mA
		R _{θJA} = 62.4 °C/W, V _I = 3.6 V, T _J = 150°C, T _A = 25°C			557	
P _S	Safety input, output, or total power ⁽¹⁾	R _{θJA} = 62.4 °C/W, T _J = 150°C, T _A = 25°C,			2004	mW
T _S	Safety temperature ⁽¹⁾				150	°C
ISO1642/3/4 DW-16 Package						
I _S	Safety input, output, or supply current ⁽¹⁾	R _{θJA} = 58.3 °C/W, V _I = 5.5 V, T _J = 150°C, T _A = 25°C			390	mA
		R _{θJA} = 58.3 °C/W, V _I = 3.6 V, T _J = 150°C, T _A = 25°C			596	
P _S	Safety input, output, or total power ⁽¹⁾	R _{θJA} = 58.3 °C/W, T _J = 150°C, T _A = 25°C			2145	mW
T _S	Safety temperature ⁽¹⁾				150	°C

- (1) The maximum safety temperature, T_S, has the same value as the maximum junction temperature, T_J, specified for the device. The I_S and P_S parameters represent the safety current and safety power respectively. The maximum limits of I_S and P_S should not be exceeded. These limits vary with the ambient temperature, T_A. The junction-to-air thermal resistance, R_{θJA}, in the table is that of a device installed on a high-K test board for leaded surface-mount packages. Use these equations to calculate the value for each parameter:
 $T_J = T_A + R_{\theta JA} \times P$, where P is the power dissipated in the device.
 $T_{J(max)} = T_S = T_A + R_{\theta JA} \times P_S$, where T_{J(max)} is the maximum allowed junction temperature.
 $P_S = I_S \times V_I$, where V_I is the maximum input voltage.

6.9 Electrical Characteristics

over recommended operating conditions, unless otherwise noted

PARAMETER		TEST CONDITIONS	MIN	TYP	MAX	UNIT
SIDE 1						
V _{ILT1}	Voltage input threshold low (SDA1 and SCL1)		480		560	mV
V _{IHT1}	Voltage input threshold high (SDA1 and SCL1)		520		620	mV
V _{HYST1}	Voltage input hysteresis	V _{IHT1} – V _{ILT1}	50	60		mV
V _{OL1}	Low-level output voltage ⁽¹⁾ (SDA1 and SCL1)	0.5 mA ≤ (I _{SDA1} and I _{SCL1}) ≤ 3.5 mA	570	650	710	mV
ΔV _{OIT1}	Low-level output voltage to high-level input voltage threshold difference, SDA1 and SCL1 ^{(2) (3)}	0.5 mA ≤ (I _{SDA1} and I _{SCL1}) ≤ 3.5 mA	50			mV
SIDE 2						
V _{ILT2}	Voltage input threshold low (SDA2 and SCL2)		0.3 × V _{CC2}		0.4 × V _{CC2}	V
V _{IHT2}	Voltage input threshold high (SDA2 and SCL2)		0.4 × V _{CC2}		0.5 × V _{CC2}	V
V _{HYST2}	Voltage input hysteresis	V _{IHT2} – V _{ILT2}	0.05 × V _{CC2}			V
V _{OL2}	Low-level output voltage (SDA2 and SCL2)	0.5 mA ≤ (I _{SDA2} and I _{SCL2}) ≤ 50 mA			0.4	V
BOTH SIDES						
I _{il}	Input leakage currents (SDA1, SCL1, SDA2, and SCL2)	V _{SDA1} , V _{SCL1} = V _{CC1} , V _{SDA2} , V _{SCL2} = V _{CC2}		0.01	10	μA
C _i	Input capacitance to local ground (SDA1, SCL1, SDA2, and SCL2)	V _i = 0.4 × sin(2e6*πt) + V _{DDX} / 2		10		pF
CMTI	Common-mode transient immunity	V _{CM} = 1000 V, see Common-Mode Transient Immunity Test Circuit	50	100		kV/μs
GPIO Channels						
V _{IOOH}	High-level output voltage	VCCx = 5 V, I _{OH} = -4 mA; ISO1642/3/4 only	V _{CCO} - 0.4			V
		VCCx = 3.3 V, I _{OH} = -2 mA; ISO1642/3/4 only	V _{CCO} - 0.3			V
		VCC1 = 2.5 V, I _{OH} = -1 mA; ISO1642/3/4 only	V _{CCO} - 0.2			V
V _{IOOL}	Low-level output voltage	VCCx = 5 V, I _{OH} = 4 mA; ISO1642/3/4 only			0.4	V
		VCCx = 3.3 V, I _{OH} = 2 mA; ISO1642/3/4 only			0.3	V
		VCC1 = 2.5 V, I _{OH} = 1 mA; ISO1642/3/4 only			0.2	V
V _{IT+(IN)}	Rising input switching threshold	ISO1642/3/4 only		0.7 × V _{CCI} ⁽¹⁾		V
V _{IT-(IN)}	Falling input switching threshold	ISO1642/3/4 only	0.3 × V _{CCI}			V
V _{I(HYS)}	Input threshold voltage hysteresis	ISO1642/3/4 only	0.1 × V _{CCI}			V
I _{IH}	High-level input current	V _{IH} = V _{CCI} ⁽¹⁾ at INx. ISO1642/3/4 only			10	μA
I _{IL}	Low-level input current	V _{IL} = 0 V at INx. ISO1642/3/4 only	-10			μA

- (1) This parameter does not apply to the SCL1 line of the ISO1641 device because it is unidirectional.
- (2) ΔV_{OIT1} = V_{OL1} – V_{IHT1}. This value represents the minimum difference between a threshold for the low-level output voltage and a threshold for the high-level input voltage to prevent a permanent latch condition that would otherwise occur with bidirectional communication.
- (3) Any supply voltages on either side that are less than the minimum value make sure that the device does a lockout. Both supply voltages that are greater than the maximum value keep the device from a lockout.

6.10 Supply Current Characteristics

over recommended operating conditions, unless otherwise noted. See [Test Diagram](#) for more information.

PARAMETER		TEST CONDITIONS		MIN	TYP	MAX	UNIT
2.25 V ≤ V_{CC2} ≤ 2.75 V							
I _{CC2}	Supply current, Side 2	ISO1640	V _{SDA1} , V _{SCL1} = GND1, V _{SDA2} , V _{SCL2} = GND2, R1 and R2 = Open, C1 and C2 = Open		4.9	6.6	mA
			V _{SDA1} , V _{SCL1} = VCC1, V _{SDA2} , V _{SCL2} = VCC2, R1 and R2 = Open, C1 and C2 = Open		2.7	3.5	mA
I _{CC2}	Supply current, Side 2	ISO1641	V _{SDA1} , V _{SCL1} = GND1, V _{SDA2} , V _{SCL2} = GND2, R1 and R2 = Open, C1 and C2 = Open		3.8	5.2	mA
			V _{SDA1} , V _{SCL1} = VCC1, V _{SDA2} , V _{SCL2} = VCC2, R1 and R2 = Open, C1 and C2 = Open		2.7	3.5	mA
I _{CC2}	Supply current, Side 2	ISO1642	V _{SDA1} , V _{SCL1} = GND1, V _{SDA2} , V _{SCL2} = GND2, R1 and R2 = Open, C1 and C2 = Open GPIOs = 0		6.3	9.2	mA
			V _{SDA1} , V _{SCL1} = VCC1, V _{SDA2} , V _{SCL2} = VCC2, R1 and R2 = Open, C1 and C2 = Open GPIOs = 1		5.5	7.8	mA
			V _{SDA1} , V _{SCL1} = VCC1, V _{SDA2} , V _{SCL2} = VCC2, R1 and R2 = Open, C1 and C2 = Open GPIOs = 0		4.3	6.0	mA
			V _{SDA1} , V _{SCL1} = GND1, V _{SDA2} , V _{SCL2} = GND2, R1 and R2 = Open, C1 and C2 = Open GPIOs = 1		7.5	10.5	mA
I _{CC2}	Supply current, Side 2	ISO1643	V _{SDA1} , V _{SCL1} = GND1, V _{SDA2} , V _{SCL2} = GND2, R1 and R2 = Open, C1 and C2 = Open GPIOs = 0		6.8	9.9	mA
			V _{SDA1} , V _{SCL1} = VCC1, V _{SDA2} , V _{SCL2} = VCC2, R1 and R2 = Open, C1 and C2 = Open GPIOs = 1		4.9	7.3	mA
			V _{SDA1} , V _{SCL1} = VCC1, V _{SDA2} , V _{SCL2} = VCC2, R1 and R2 = Open, C1 and C2 = Open GPIOs = 0		4.8	6.7	mA
			V _{SDA1} , V _{SCL1} = GND1, V _{SDA2} , V _{SCL2} = GND2, R1 and R2 = Open, C1 and C2 = Open GPIOs = 1		6.9	9.8	mA
I _{CC2}	Supply current, Side 2	ISO1644	V _{SDA1} , V _{SCL1} = GND1, V _{SDA2} , V _{SCL2} = GND2, R1 and R2 = Open, C1 and C2 = Open GPIOs = 0		6.8	10	mA
			V _{SDA1} , V _{SCL1} = VCC1, V _{SDA2} , V _{SCL2} = VCC2, R1 and R2 = Open, C1 and C2 = Open GPIOs = 1		6	8.7	mA
			V _{SDA1} , V _{SCL1} = VCC1, V _{SDA2} , V _{SCL2} = VCC2, R1 and R2 = Open, C1 and C2 = Open GPIOs = 0		4.8	6.7	mA
			V _{SDA1} , V _{SCL1} = GND1, V _{SDA2} , V _{SCL2} = GND2, R1 and R2 = Open, C1 and C2 = Open GPIOs = 1		7.9	11.2	mA
3 V ≤ V_{CC1}, V_{CC2} ≤ 3.6 V							
I _{CC1}	Supply current, Side 1	ISO1640	V _{SDA1} , V _{SCL1} = GND1, V _{SDA2} , V _{SCL2} = GND2, R1 and R2 = Open, C1 and C2 = Open		5.2	7.1	mA
			V _{SDA1} , V _{SCL1} = VCC1, V _{SDA2} , V _{SCL2} = VCC2, R1 and R2 = Open, C1 and C2 = Open		3	4	mA
I _{CC1}	Supply current, Side 1	ISO1641	V _{SDA1} , V _{SCL1} = GND1, V _{SDA2} , V _{SCL2} = GND2, R1 and R2 = Open, C1 and C2 = Open		4.6	6.1	mA
			V _{SDA1} , V _{SCL1} = VCC1, V _{SDA2} , V _{SCL2} = VCC2, R1 and R2 = Open, C1 and C2 = Open		2.4	3.2	mA

over recommended operating conditions, unless otherwise noted. See [Test Diagram](#) for more information.

PARAMETER			TEST CONDITIONS	MIN	TYP	MAX	UNIT
I _{CC1}	Supply current, Side 1	ISO1642	V _{SDA1} , V _{SCL1} = GND1, V _{SDA2} , V _{SCL2} = GND2, R1 and R2 = Open, C1 and C2 = Open GPIOs = 0		7.3	9.6	mA
			V _{SDA1} , V _{SCL1} = VCC1, V _{SDA2} , V _{SCL2} = VCC2, R1 and R2 = Open, C1 and C2 = Open GPIOs = 1		5.8	8.3	mA
			V _{SDA1} , V _{SCL1} = VCC1, V _{SDA2} , V _{SCL2} = VCC2, R1 and R2 = Open, C1 and C2 = Open GPIOs = 0		4.7	6.6	mA
			V _{SDA1} , V _{SCL1} = GND1, V _{SDA2} , V _{SCL2} = GND2, R1 and R2 = Open, C1 and C2 = Open GPIOs = 1		8.4	11.6	mA
I _{CC1}	Supply current, Side 1	ISO1643	V _{SDA1} , V _{SCL1} = GND1, V _{SDA2} , V _{SCL2} = GND2, R1 and R2 = Open, C1 and C2 = Open GPIOs = 0		6.9	8.9	mA
			V _{SDA1} , V _{SCL1} = VCC1, V _{SDA2} , V _{SCL2} = VCC2, R1 and R2 = Open, C1 and C2 = Open GPIOs = 1		6.5	8.9	mA
			V _{SDA1} , V _{SCL1} = VCC1, V _{SDA2} , V _{SCL2} = VCC2, R1 and R2 = Open, C1 and C2 = Open GPIOs = 0		4.3	5.9	mA
			V _{SDA1} , V _{SCL1} = GND1, V _{SDA2} , V _{SCL2} = GND2, R1 and R2 = Open, C1 and C2 = Open GPIOs = 1		9	12.3	mA
I _{CC1}	Supply current, Side 1	ISO1644	V _{SDA1} , V _{SCL1} = GND1, V _{SDA2} , V _{SCL2} = GND2, R1 and R2 = Open, C1 and C2 = Open GPIOs = 0		7.3	10.1	mA
			V _{SDA1} , V _{SCL1} = VCC1, V _{SDA2} , V _{SCL2} = VCC2, R1 and R2 = Open, C1 and C2 = Open GPIOs = 1		6.9	9.6	mA
			V _{SDA1} , V _{SCL1} = VCC1, V _{SDA2} , V _{SCL2} = VCC2, R1 and R2 = Open, C1 and C2 = Open GPIOs = 0		4.7	6.6	mA
			V _{SDA1} , V _{SCL1} = GND1, V _{SDA2} , V _{SCL2} = GND2, R1 and R2 = Open, C1 and C2 = Open GPIOs = 1		9.5	13.1	mA
I _{CC2}	Supply current, Side 2	ISO1640	V _{SDA1} , V _{SCL1} = GND1, V _{SDA2} , V _{SCL2} = GND2, R1 and R2 = Open, C1 and C2 = Open		4.9	6.7	mA
			V _{SDA1} , V _{SCL1} = VCC1, V _{SDA2} , V _{SCL2} = VCC2, R1 and R2 = Open, C1 and C2 = Open		2.8	3.5	mA
I _{CC2}	Supply current, Side 2	ISO1641	V _{SDA1} , V _{SCL1} = GND1, V _{SDA2} , V _{SCL2} = GND2, R1 and R2 = Open, C1 and C2 = Open		3.9	5.2	mA
			V _{SDA1} , V _{SCL1} = VCC1, V _{SDA2} , V _{SCL2} = VCC2, R1 and R2 = Open, C1 and C2 = Open		2.8	3.5	mA
I _{CC2}	Supply current, Side 2	ISO1642	V _{SDA1} , V _{SCL1} = GND1, V _{SDA2} , V _{SCL2} = GND2, R1 and R2 = Open, C1 and C2 = Open GPIOs = 0		6.4	9.2	mA
			V _{SDA1} , V _{SCL1} = VCC1, V _{SDA2} , V _{SCL2} = VCC2, R1 and R2 = Open, C1 and C2 = Open GPIOs = 1		5.6	7.8	mA
			V _{SDA1} , V _{SCL1} = VCC1, V _{SDA2} , V _{SCL2} = VCC2, R1 and R2 = Open, C1 and C2 = Open GPIOs = 0		4.4	6.0	mA
			V _{SDA1} , V _{SCL1} = GND1, V _{SDA2} , V _{SCL2} = GND2, R1 and R2 = Open, C1 and C2 = Open GPIOs = 1		7.6	10.5	mA

over recommended operating conditions, unless otherwise noted. See [Test Diagram](#) for more information.

PARAMETER			TEST CONDITIONS	MIN	TYP	MAX	UNIT
I _{CC2}	Supply current, Side 2	ISO1643	V _{SDA1} , V _{SCL1} = GND1, V _{SDA2} , V _{SCL2} = GND2, R1 and R2 = Open, C1 and C2 = Open GPIOs = 0		6.8	9.9	mA
			V _{SDA1} , V _{SCL1} = VCC1, V _{SDA2} , V _{SCL2} = VCC2, R1 and R2 = Open, C1 and C2 = Open GPIOs = 1		4.9	7.3	mA
			V _{SDA1} , V _{SCL1} = VCC1, V _{SDA2} , V _{SCL2} = VCC2, R1 and R2 = Open, C1 and C2 = Open GPIOs = 0		4.8	6.7	mA
			V _{SDA1} , V _{SCL1} = GND1, V _{SDA2} , V _{SCL2} = GND2, R1 and R2 = Open, C1 and C2 = Open GPIOs = 1		6.9	9.8	mA
I _{CC2}	Supply current, Side 2	ISO1644	V _{SDA1} , V _{SCL1} = GND1, V _{SDA2} , V _{SCL2} = GND2, R1 and R2 = Open, C1 and C2 = Open GPIOs = 0		6.8	10	mA
			V _{SDA1} , V _{SCL1} = VCC1, V _{SDA2} , V _{SCL2} = VCC2, R1 and R2 = Open, C1 and C2 = Open GPIOs = 1		6	8.4	mA
			V _{SDA1} , V _{SCL1} = VCC1, V _{SDA2} , V _{SCL2} = VCC2, R1 and R2 = Open, C1 and C2 = Open GPIOs = 0		4.8	6.7	mA
			V _{SDA1} , V _{SCL1} = GND1, V _{SDA2} , V _{SCL2} = GND2, R1 and R2 = Open, C1 and C2 = Open GPIOs = 1		8	11.3	mA
4.5 V ≤ V_{CC1}, V_{CC2} ≤ 5.5 V							
I _{CC1}	Supply current, Side 1	ISO1640	V _{SDA1} , V _{SCL1} = GND1, V _{SDA2} , V _{SCL2} = GND2, R1 and R2 = Open, C1 and C2 = Open		5.3	7.2	mA
			V _{SDA1} , V _{SCL1} = VCC1, V _{SDA2} , V _{SCL2} = VCC2, R1 and R2 = Open, C1 and C2 = Open		3	4.1	mA
I _{CC1}	Supply current, Side 1	ISO1641	V _{SDA1} , V _{SCL1} = GND1, V _{SDA2} , V _{SCL2} = GND2, R1 and R2 = Open, C1 and C2 = Open		4.7	6.2	mA
			V _{SDA1} , V _{SCL1} = VCC1, V _{SDA2} , V _{SCL2} = VCC2, R1 and R2 = Open, C1 and C2 = Open		2.5	3.2	mA
I _{CC1}	Supply current, Side 1	ISO1642	V _{SDA1} , V _{SCL1} = GND1, V _{SDA2} , V _{SCL2} = GND2, R1 and R2 = Open, C1 and C2 = Open GPIOs = 0		7.6	10.4	mA
			V _{SDA1} , V _{SCL1} = VCC1, V _{SDA2} , V _{SCL2} = VCC2, R1 and R2 = Open, C1 and C2 = Open GPIOs = 1		5.9	8.2	mA
			V _{SDA1} , V _{SCL1} = VCC1, V _{SDA2} , V _{SCL2} = VCC2, R1 and R2 = Open, C1 and C2 = Open GPIOs = 0		4.7	6.7	mA
			V _{SDA1} , V _{SCL1} = GND1, V _{SDA2} , V _{SCL2} = GND2, R1 and R2 = Open, C1 and C2 = Open GPIOs = 1		8.7	12	mA
I _{CC1}	Supply current, Side 1	ISO1643	V _{SDA1} , V _{SCL1} = GND1, V _{SDA2} , V _{SCL2} = GND2, R1 and R2 = Open, C1 and C2 = Open GPIOs = 0		7.2	9.7	mA
			V _{SDA1} , V _{SCL1} = VCC1, V _{SDA2} , V _{SCL2} = VCC2, R1 and R2 = Open, C1 and C2 = Open GPIOs = 1		6.5	8.9	mA
			V _{SDA1} , V _{SCL1} = VCC1, V _{SDA2} , V _{SCL2} = VCC2, R1 and R2 = Open, C1 and C2 = Open GPIOs = 0		4.3	6	mA
			V _{SDA1} , V _{SCL1} = GND1, V _{SDA2} , V _{SCL2} = GND2, R1 and R2 = Open, C1 and C2 = Open GPIOs = 1		9.3	12.7	mA

over recommended operating conditions, unless otherwise noted. See [Test Diagram](#) for more information.

PARAMETER			TEST CONDITIONS	MIN	TYP	MAX	UNIT
I _{CC1}	Supply current, Side 1	ISO1644	V _{SDA1} , V _{SCL1} = GND1, V _{SDA2} , V _{SCL2} = GND2, R1 and R2 = Open, C1 and C2 = Open GPIOs = 0		7.6	10.4	mA
			V _{SDA1} , V _{SCL1} = VCC1, V _{SDA2} , V _{SCL2} = VCC2, R1 and R2 = Open, C1 and C2 = Open GPIOs = 1		7	9.7	mA
			V _{SDA1} , V _{SCL1} = VCC1, V _{SDA2} , V _{SCL2} = VCC2, R1 and R2 = Open, C1 and C2 = Open GPIOs = 0		4.7	6.7	mA
			V _{SDA1} , V _{SCL1} = GND1, V _{SDA2} , V _{SCL2} = GND2, R1 and R2 = Open, C1 and C2 = Open GPIOs = 1		9.6	13.5	mA
I _{CC2}	Supply current, Side 2	ISO1640	V _{SDA1} , V _{SCL1} = GND1, V _{SDA2} , V _{SCL2} = GND2, R1 and R2 = Open, C1 and C2 = Open		5	6.8	mA
			V _{SDA1} , V _{SCL1} = VCC1, V _{SDA2} , V _{SCL2} = VCC2, R1 and R2 = Open, C1 and C2 = Open		2.8	3.6	mA
I _{CC2}	Supply current, Side 2	ISO1641	V _{SDA1} , V _{SCL1} = GND1, V _{SDA2} , V _{SCL2} = GND2, R1 and R2 = Open, C1 and C2 = Open		3.9	5.3	mA
			V _{SDA1} , V _{SCL1} = VCC1, V _{SDA2} , V _{SCL2} = VCC2, R1 and R2 = Open, C1 and C2 = Open		2.8	3.6	mA
I _{CC2}	Supply current, Side 2	ISO1642	V _{SDA1} , V _{SCL1} = GND1, V _{SDA2} , V _{SCL2} = GND2, R1 and R2 = Open, C1 and C2 = Open GPIOs = 0		6.5	9.1	mA
			V _{SDA1} , V _{SCL1} = VCC1, V _{SDA2} , V _{SCL2} = VCC2, R1 and R2 = Open, C1 and C2 = Open GPIOs = 1		5.6	7.7	mA
			V _{SDA1} , V _{SCL1} = VCC1, V _{SDA2} , V _{SCL2} = VCC2, R1 and R2 = Open, C1 and C2 = Open GPIOs = 0		4.5	6.1	mA
			V _{SDA1} , V _{SCL1} = GND1, V _{SDA2} , V _{SCL2} = GND2, R1 and R2 = Open, C1 and C2 = Open GPIOs = 1		7.7	10.7	mA
I _{CC2}	Supply current, Side 2	ISO1643	V _{SDA1} , V _{SCL1} = GND1, V _{SDA2} , V _{SCL2} = GND2, R1 and R2 = Open, C1 and C2 = Open GPIOs = 0		6.9	9.8	mA
			V _{SDA1} , V _{SCL1} = VCC1, V _{SDA2} , V _{SCL2} = VCC2, R1 and R2 = Open, C1 and C2 = Open GPIOs = 1		5	7	mA
			V _{SDA1} , V _{SCL1} = VCC1, V _{SDA2} , V _{SCL2} = VCC2, R1 and R2 = Open, C1 and C2 = Open GPIOs = 0		4.9	6.8	mA
			V _{SDA1} , V _{SCL1} = GND1, V _{SDA2} , V _{SCL2} = GND2, R1 and R2 = Open, C1 and C2 = Open GPIOs = 1		7	10	mA
I _{CC2}	Supply current, Side 2	ISO1644	V _{SDA1} , V _{SCL1} = GND1, V _{SDA2} , V _{SCL2} = GND2, R1 and R2 = Open, C1 and C2 = Open GPIOs = 0		6.9	9.8	mA
			V _{SDA1} , V _{SCL1} = VCC1, V _{SDA2} , V _{SCL2} = VCC2, R1 and R2 = Open, C1 and C2 = Open GPIOs = 1		6.1	8.5	mA
			V _{SDA1} , V _{SCL1} = VCC1, V _{SDA2} , V _{SCL2} = VCC2, R1 and R2 = Open, C1 and C2 = Open GPIOs = 0		4.9	6.8	mA
			V _{SDA1} , V _{SCL1} = GND1, V _{SDA2} , V _{SCL2} = GND2, R1 and R2 = Open, C1 and C2 = Open GPIOs = 1		8.1	11.5	mA

6.11 Timing Requirements

			MIN	NOM	MAX	UNIT
t _{UVLO}	Time to recover from UVLO	VCC1 > V _{CC1(UVLO+)} or VCC2 > V _{CC2(UVLO+)} , I2C bus Idle. see t_{UVLO} Test Circuit and Timing Diagrams	36	95	151	μs

6.12 I2C Switching Characteristics

over recommended operating conditions, unless otherwise noted

PARAMETER		TEST CONDITIONS	MIN	TYP	MAX	UNIT
2.25 V ≤ V_{CC2} ≤ 2.75 V, 3 V ≤ V_{CC1} ≤ 3.6 V						
t _{f2}	Output signal fall time (SDA2 and SCL2)	0.7 × V _{CC2} ≥ V _O ≥ 0.3 × V _{CC2} , R2 = 72 Ω, C2 = 400 pF, see Test Diagram	16	26.5	40	ns
		0.9 × V _{CC2} ≥ V _O ≥ 400 mV, R2 = 72 Ω, C2 = 400 pF, see Test Diagram	38	53.3	78	
t _{pLH1-2}	Low-to-high propagation delay, side 1 to side 2	V _I = 535 mV, V _O = 0.7 × V _{CC2} , R1 = 953 Ω, R2 = 72 Ω, C1 and C2 = 10 pF, V _{CC1} = 3.3 V, see Test Diagram		20	30	ns
t _{pHL1-2}	High-to-low propagation delay, side 1 to side 2	V _I = 550 mV, V _O = 0.3 × V _{CC2} , R1 = 953 Ω, R2 = 72 Ω, C1 and C2 = 10 pF, V _{CC1} = 3.3 V, see Test Diagram		80	130	ns
t _{pLH2-1}	Low-to-high propagation delay, side 2 to side 1 ⁽¹⁾	V _I = 0.4 × V _{CC2} , V _O = 0.7 × V _{CC1} , R1 = 953 Ω, R2 = 72 Ω, C1 and C2 = 10 pF, V _{CC1} = 3.3 V, see Test Diagram		40	48	ns
t _{pHL2-1}	High-to-low propagation delay, side 2 to side 1 ⁽¹⁾	V _I = 0.4 × V _{CC2} , V _O = 0.3 × V _{CC1} , R1 = 953 Ω, R2 = 72 Ω, C1 and C2 = 10 pF, V _{CC1} = 3.3 V, see Test Diagram		70	100	ns
PWD ₁₋₂	Pulse width distortion t _{pHL1-2} - t _{pLH1-2}	R1 = 953 Ω, R2 = 72 Ω, C1 and C2 = 10 pF, V _{CC1} = 3.3 V see Test Diagram		60	104	ns
PWD ₂₋₁	Pulse width distortion ⁽¹⁾ t _{pHL2-1} - t _{pLH2-1}	R1 = 953 Ω, R2 = 72 Ω, C1 and C2 = 10 pF, V _{CC1} = 3.3 V see Test Diagram		25	55	ns
t _{LOOP1}	Round-trip propagation delay on side 1 ⁽¹⁾	0.4 V ≤ V _I ≤ 0.3 × V _{CC1} , R1 = 953 Ω, C1 = 40 pF, R2 = 72 Ω, C2 = 400 pF, see Test Diagram		62	74	ns
3 V ≤ V_{CC1}, V_{CC2} ≤ 3.6 V						
t _{f1}	Output signal fall time (SDA1 and SCL1)	0.7 × V _{CC1} ≥ V _O ≥ 0.3 × V _{CC1} , R1 = 953 Ω, C1 = 40 pF, R2 = 95.3 Ω, C2 = 400 pF, see Test Diagram	8	17	29	ns
		0.9 × V _{CC1} ≥ V _O ≥ 900 mV, R1 = 953 Ω, C1 = 40 pF, see Test Diagram	15	25	48	
t _{f2}	Output signal fall time (SDA2 and SCL2)	0.7 × V _{CC2} ≥ V _O ≥ 0.3 × V _{CC2} , R2 = 95.3 Ω, C2 = 400 pF, see Test Diagram	14	23	47	ns
		0.9 × V _{CC2} ≥ V _O ≥ 400 mV, R2 = 95.3 Ω, C2 = 400 pF, see Test Diagram	30	50	100	
t _{pLH1-2}	Low-to-high propagation delay, side 1 to side 2	V _I = 535 mV, V _O = 0.7 × V _{CC2} , R1 = 953 Ω, R2 = 95.3 Ω, C1 and C2 = 10 pF, see Test Diagram		21	29	ns
t _{pHL1-2}	High-to-low propagation delay, side 1 to side 2	V _I = 550 mV, V _O = 0.3 × V _{CC2} , R1 = 953 Ω, R2 = 95.3 Ω, C1 and C2 = 10 pF, see Test Diagram		59	88	ns
t _{pLH2-1}	Low-to-high propagation delay, side 2 to side 1 ⁽¹⁾	V _I = 0.4 × V _{CC2} , V _O = 0.7 × V _{CC1} , R1 = 953 Ω, R2 = 95.3 Ω, C1 and C2 = 10 pF, see Test Diagram		40	47	ns
t _{pHL2-1}	High-to-low propagation delay, side 2 to side 1 ⁽¹⁾	V _I = 0.4 × V _{CC2} , V _O = 0.3 × V _{CC1} , R1 = 953 Ω, R2 = 95.3 Ω, C1 and C2 = 10 pF, see Test Diagram		70	100	ns
PWD ₁₋₂	Pulse width distortion t _{pHL1-2} - t _{pLH1-2}	R1 = 953 Ω, R2 = 95.3 Ω, C1 and C2 = 10 pF, see Test Diagram		39	61	ns
PWD ₂₋₁	Pulse width distortion ⁽¹⁾ t _{pHL2-1} - t _{pLH2-1}	R1 = 953 Ω, R2 = 95.3 Ω, C1 and C2 = 10 pF, see Test Diagram		25	48	ns
t _{LOOP1}	Round-trip propagation delay on side 1 ⁽¹⁾	0.4 V ≤ V _I ≤ 0.3 × V _{CC1} , R1 = 953 Ω, C1 = 40 pF, R2 = 95.3 Ω, C2 = 400 pF, see Test Diagram		65	78	ns

over recommended operating conditions, unless otherwise noted

PARAMETER		TEST CONDITIONS	MIN	TYP	MAX	UNIT
4.5 V ≤ V_{CC1}, V_{CC2} ≤ 5.5 V						
t _{fr1}	Output signal fall time (SDA1 and SCL1)	0.7 × V _{CC1} ≥ V _O ≥ 0.3 × V _{CC1} , R1 = 1430 Ω, C1 = 40 pF, R2 = 95.3 Ω, C2 = 400 pF, see Test Diagram	6	16	22	ns
		0.9 × V _{CC1} ≥ V _O ≥ 900 mV, R1 = 1430 Ω, C1 = 40 pF, see Test Diagram	13	32	48	
t _{fr2}	Output signal fall time (SDA2 and SCL2)	0.7 × V _{CC2} ≥ V _O ≥ 0.3 × V _{CC2} , R2 = 143 Ω, C2 = 400 pF, see Test Diagram	10	24	30	ns
		0.9 × V _{CC2} ≥ V _O ≥ 400 mV, R2 = 143 Ω, C2 = 400 pF, see Test Diagram	28	48	76	
t _{pLH1-2}	Low-to-high propagation delay, side 1 to side 2	V _I = 535 mV, V _O = 0.7 × V _{CC2} , R1 = 1430 Ω, R2 = 143 Ω, C1 and C2 = 10 pF, see Test Diagram		21	28	ns
t _{pHL1-2}	High-to-low propagation delay, side 1 to side 2	V _I = 550 mV, V _O = 0.3 × V _{CC2} , R1 = 1430 Ω, R2 = 143 Ω, C1 and C2 = 10 pF, see Test Diagram		51	70	ns
t _{pLH2-1}	Low-to-high propagation delay, side 2 to side 1 ⁽¹⁾	V _I = 0.4 × V _{CC2} , V _O = 0.7 × V _{CC1} , R1 = 1430 Ω, R2 = 143 Ω, C1 and C2 = 10 pF, see Test Diagram		51	57	ns
t _{pHL2-1}	High-to-low propagation delay, side 2 to side 1 ⁽¹⁾	V _I = 0.4 × V _{CC2} , V _O = 0.3 × V _{CC1} , R1 = 1430 Ω, R2 = 143 Ω, C1 and C2 = 10 pF, see Test Diagram		60	88	ns
PWD ₁₋₂	Pulse width distortion t _{pHL1-2} – t _{pLH1-2}	R1 = 1430 Ω, R2 = 143 Ω, C1 and C2 = 10 pF, see Test Diagram		30	45	ns
PWD ₂₋₁	Pulse width distortion ⁽¹⁾ t _{pHL2-1} – t _{pLH2-1}	R1 = 1430 Ω, R2 = 143 Ω, C1 and C2 = 10 pF, see Test Diagram		10	34	ns
t _{LOOP1}	Round-trip propagation delay on side 1 ⁽¹⁾	0.4 V ≤ V _I ≤ 0.3 × V _{CC1} , R1 = 1430 Ω, C1 = 40 pF, R2 = 143 Ω, C2 = 400 pF, see Test Diagram		84	96	ns

(1) This parameter does not apply to the SCL1 line of the ISO1641 device because it is unidirectional.

6.13 GPIO Switching Characteristics

over recommended operating conditions, unless otherwise noted. ISO1644 only.

PARAMETER		TEST CONDITIONS	MIN	TYP	MAX	UNIT
3 V ≤ V_{CC1}, V_{CC2} ≤ 3.6 V						
t _{PLH} , t _{PHL}	Propagation delay time	See Test Diagram		11	20	ns
t _{P(dft)}	Propagation delay drift			9.2		ps/°C
t _{UI}	Minimum pulse width		20			ns
PWD	Pulse width distortion	See Test Diagram			7	ns
t _{sk(o)}	Channel to channel output skew time	Same direction channels			6	ns
t _{sk(p-p)}	Part to part skew time				6	ns
t _r	Output signal rise time	See Test Diagram			6.5	ns
t _f	Output signal fall time	See Test Diagram			6.5	ns
t _{DO}	Default output delay time from input power loss	Measured from the time VCC goes below 1.2V. See Test Diagram		0.1	0.3	us
t _{ie}	Time interval error			0.8		ns
4.5 V ≤ V_{CC1}, V_{CC2} ≤ 5.5 V						
t _{PLH} , t _{PHL}	Propagation delay time	See Test Diagram		11	18	ns
t _{P(dft)}	Propagation delay drift			8		ps/°C
t _{UI}	Minimum pulse width		20			ns
PWD	Pulse width distortion	See Test Diagram			7	ns
t _{sk(o)}	Channel to channel output skew time	Same direction channels			6	ns
t _{sk(p-p)}	Part to part skew time				6	ns
t _r	Output signal rise time	See Test Diagram			6	ns
t _f	Output signal fall time	See Test Diagram			6	ns
t _{DO}	Default output delay time from input power loss	Measured from the time VCC goes below 1.2V. See Test Diagram		0.1	0.3	us
t _{ie}	Time interval error			0.8		ns

6.14 Insulation Characteristics Curves

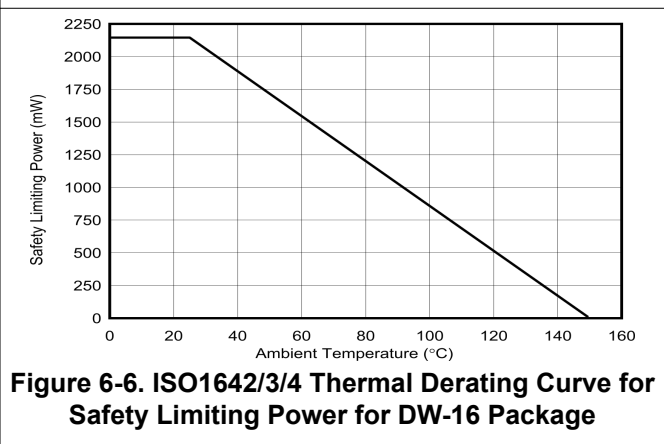
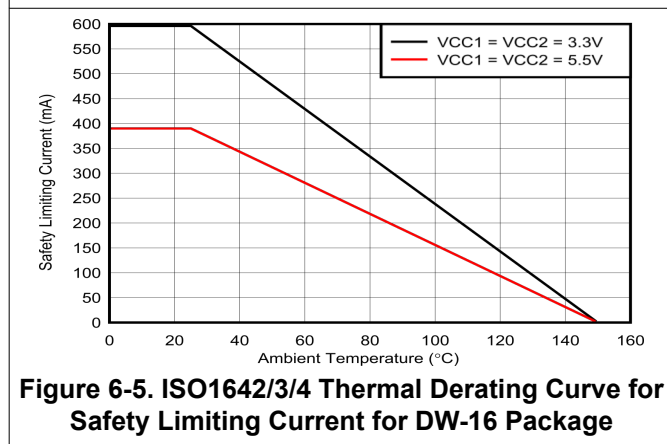
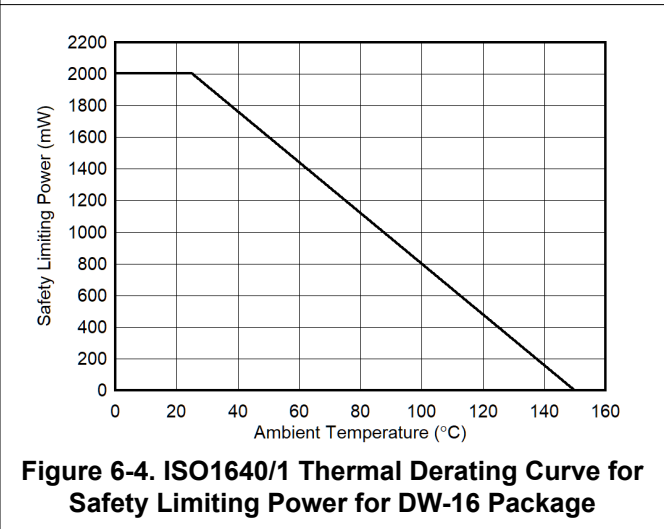
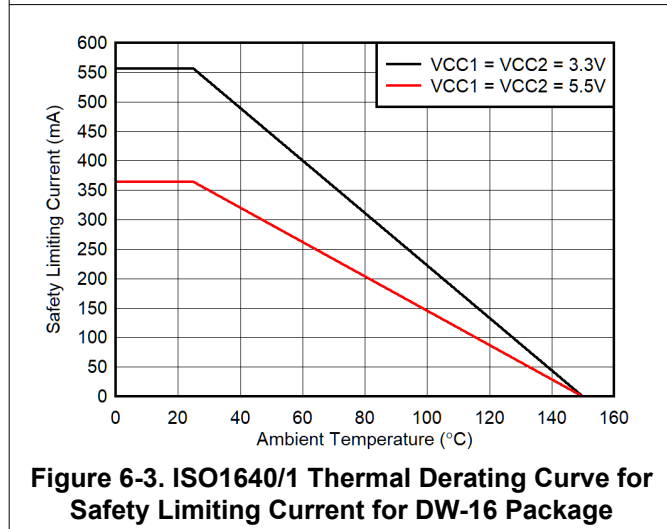
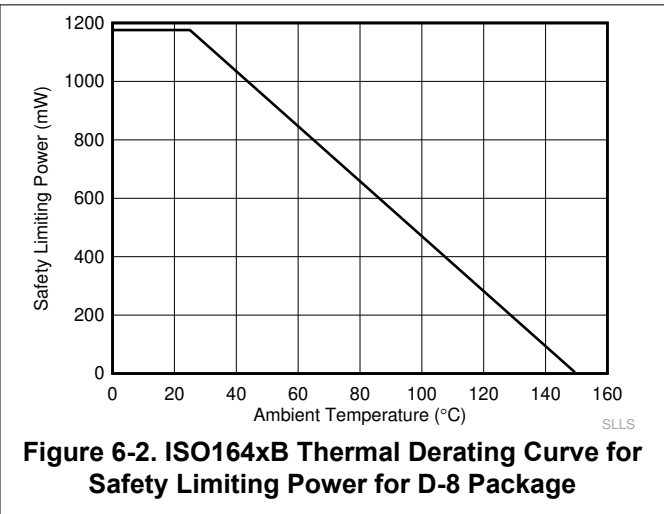
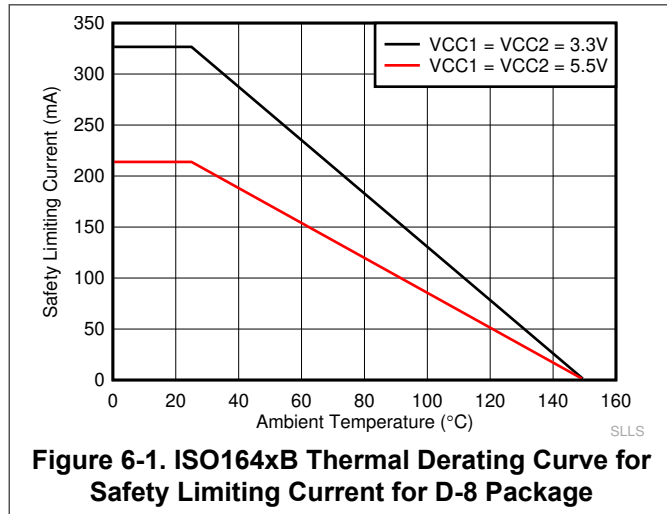

6.15 Typical Characteristics

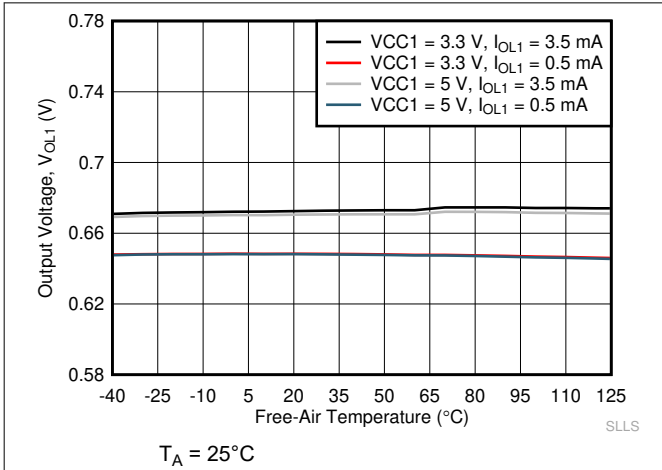

Figure 6-7. Side 1: Output Low Voltage vs Free-Air Temperature

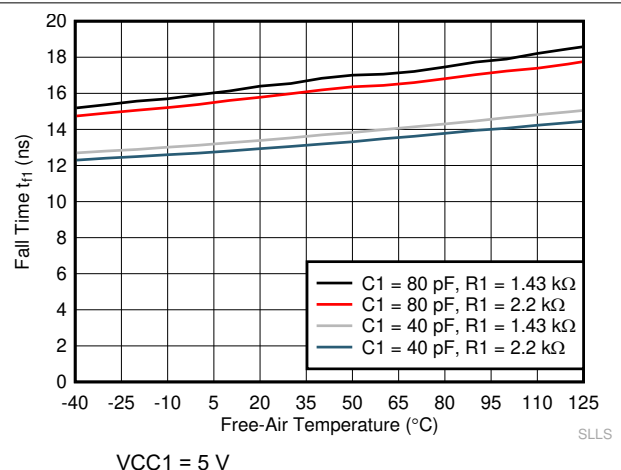

Figure 6-8. Side 1: Output Fall Time vs Free-Air Temperature

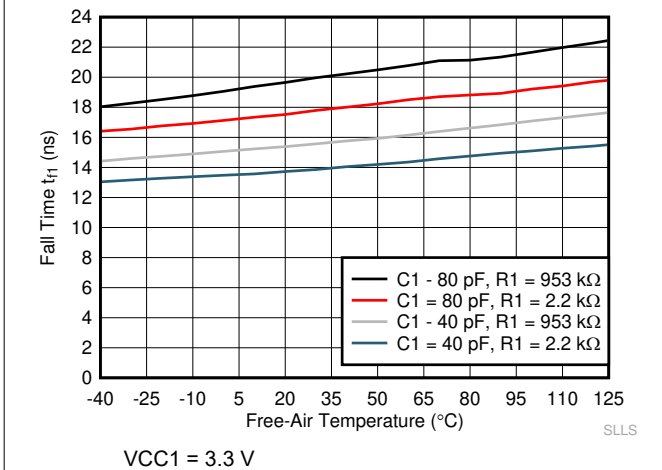

Figure 6-9. Side 1: Output Fall Time vs Free-Air Temperature

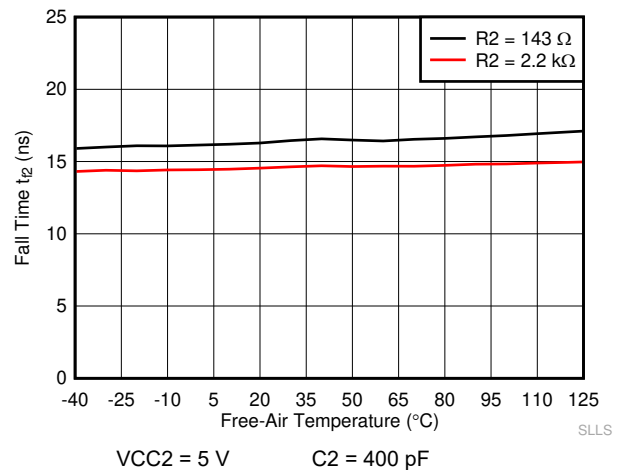

Figure 6-10. Side 2: Output Fall Time vs Free-Air Temperature

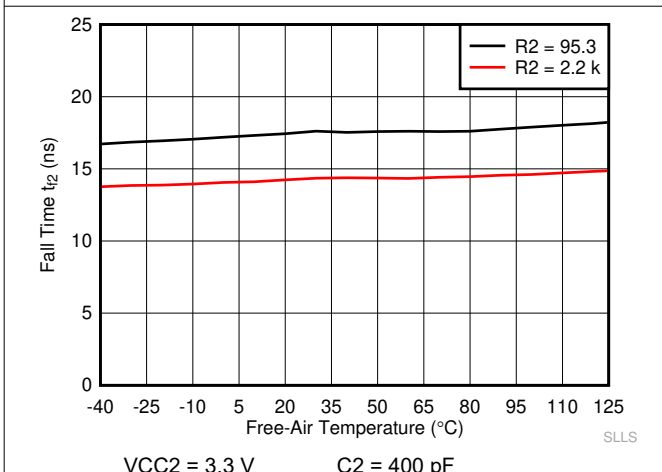

Figure 6-11. Side 2: Output Fall Time vs Free-Air Temperature

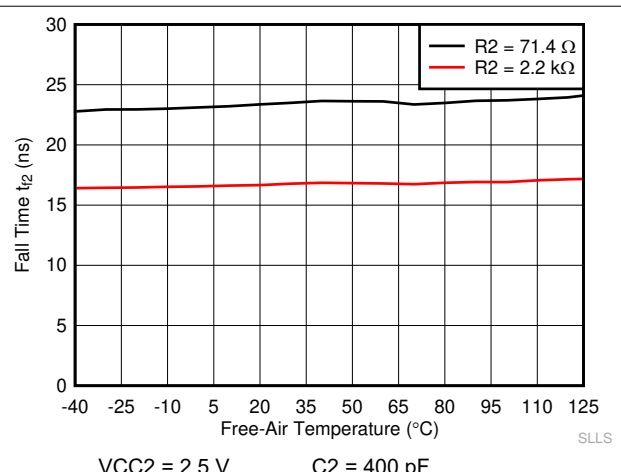

Figure 6-12. Side 2: Output Fall Time vs Free-Air Temperature

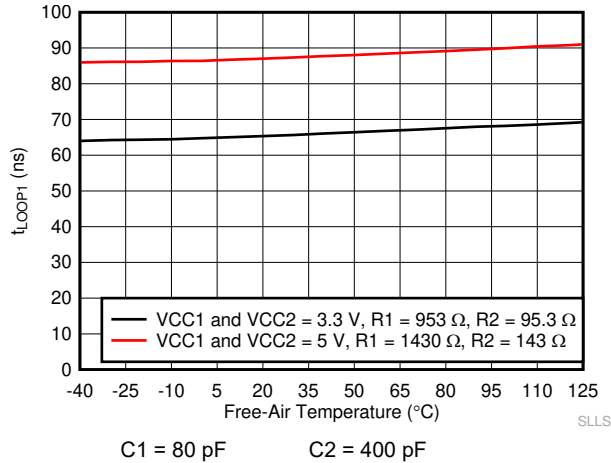

Figure 6-13. t_{LOOP1} vs Free-Air Temperature

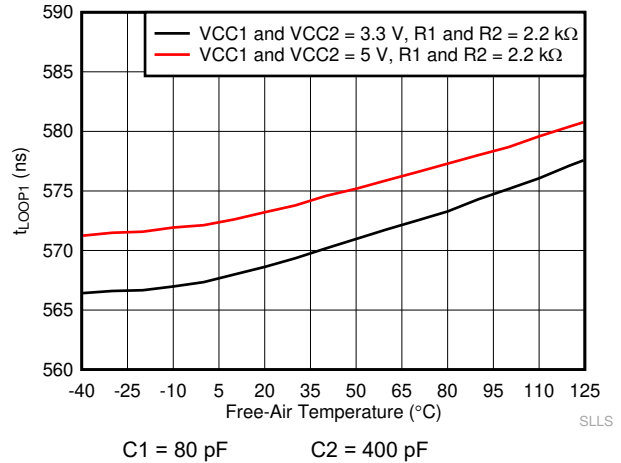

Figure 6-14. t_{LOOP1} vs Free-Air Temperature

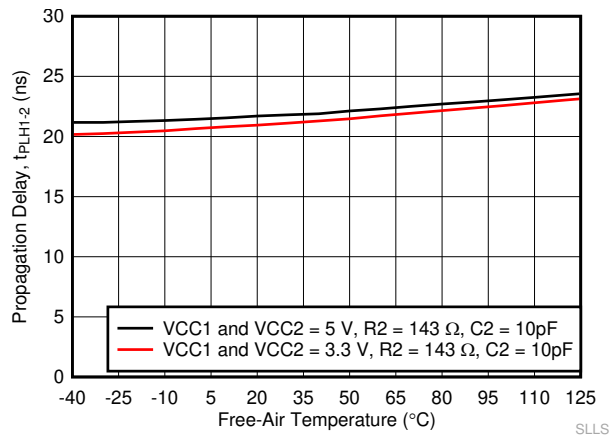

Figure 6-15. t_{PLH1-2} Propagation Delay vs Free-Air Temperature

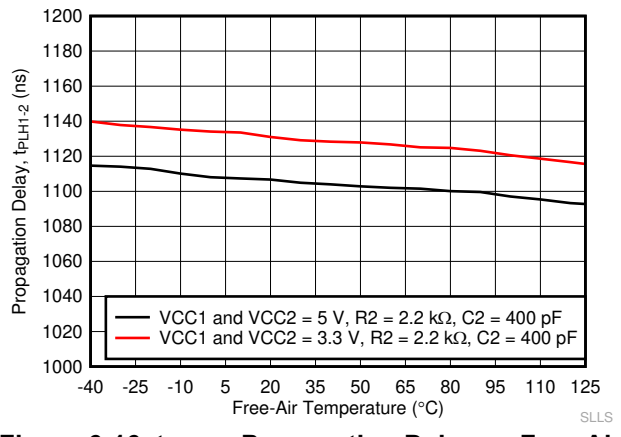

Figure 6-16. t_{PLH1-2} Propagation Delay vs Free-Air Temperature

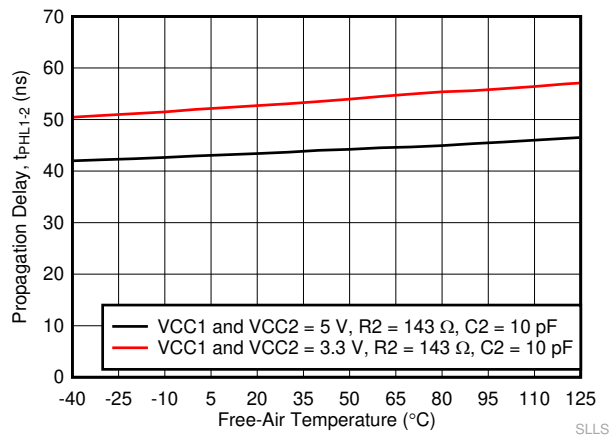

Figure 6-17. t_{PHL1-2} Propagation Delay vs Free-Air Temperature

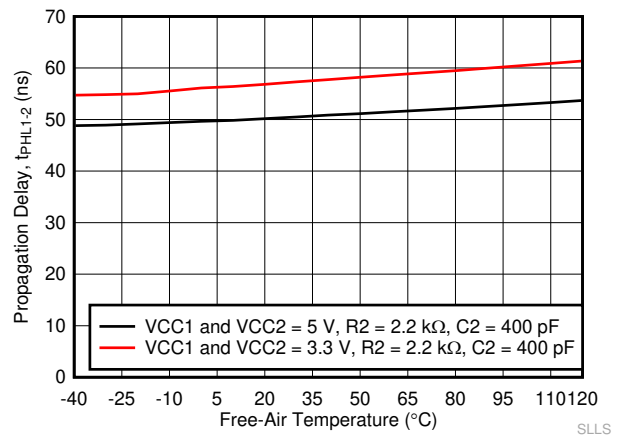

Figure 6-18. t_{PHL1-2} Propagation Delay vs Free-Air Temperature

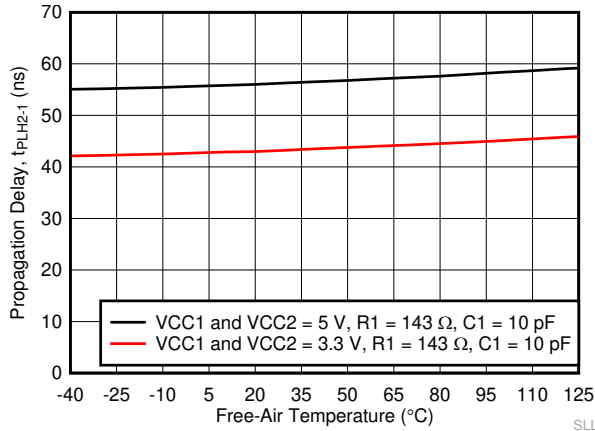

Figure 6-19. t_{PLH2-1} Propagation Delay vs Free-Air Temperature

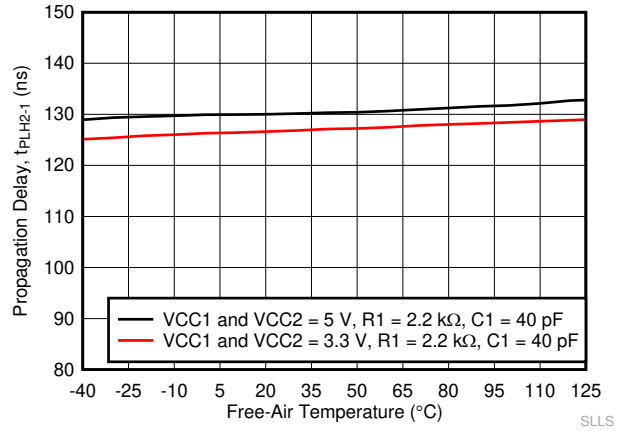

Figure 6-20. t_{PLH2-1} Propagation Delay vs Free-Air Temperature

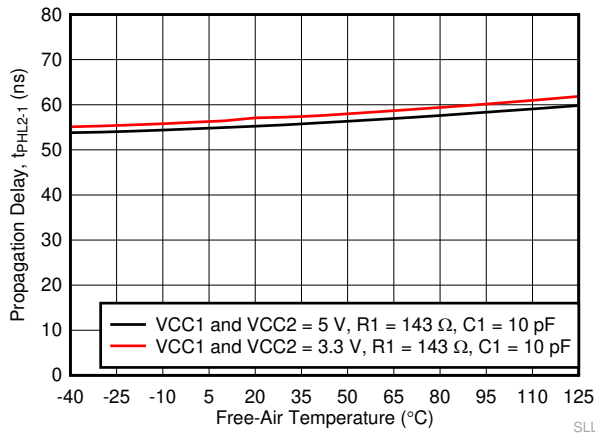

Figure 6-21. t_{PHL2-1} Propagation Delay vs Free-Air Temperature

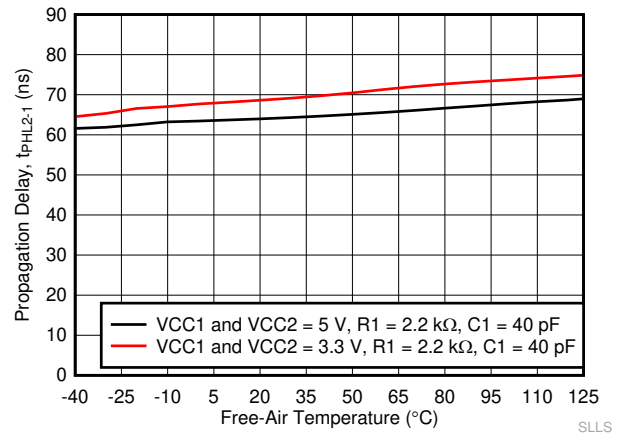

Figure 6-22. t_{PHL2-1} Propagation Delay vs Free-Air Temperature

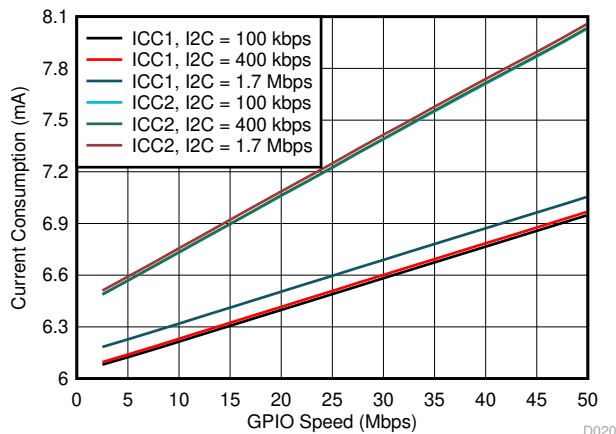

Figure 6-23. ISO1642: ICC vs GPIO Speed at 3.3V

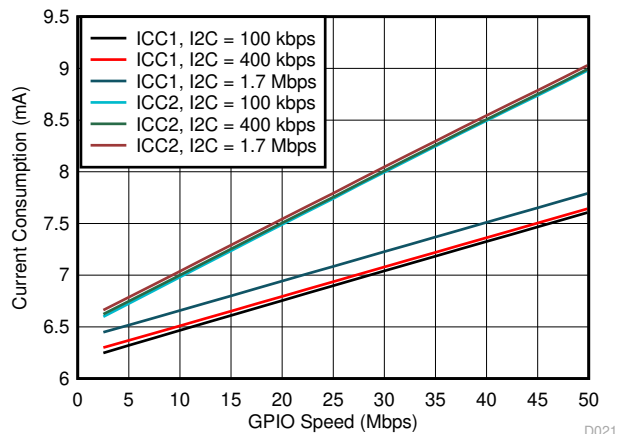

Figure 6-24. ISO1642: ICC vs GPIO Speed at 5V

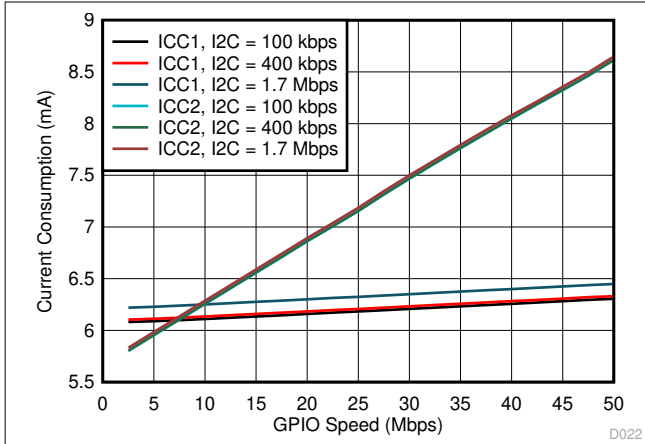

Figure 6-25. ISO1643: ICC vs GPIO Speed at 3.3V

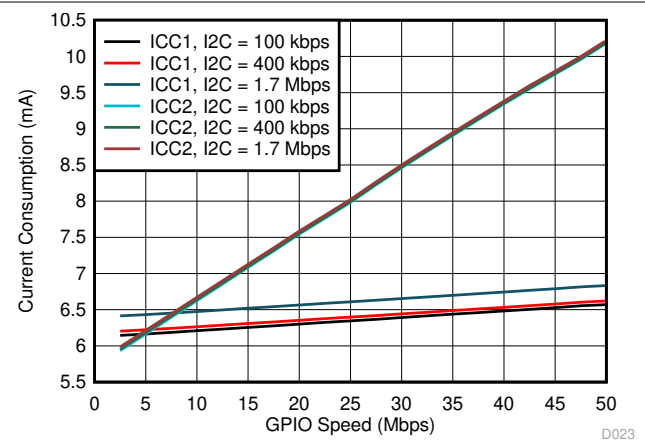

Figure 6-26. ISO1643: ICC vs GPIO Speed at 5V

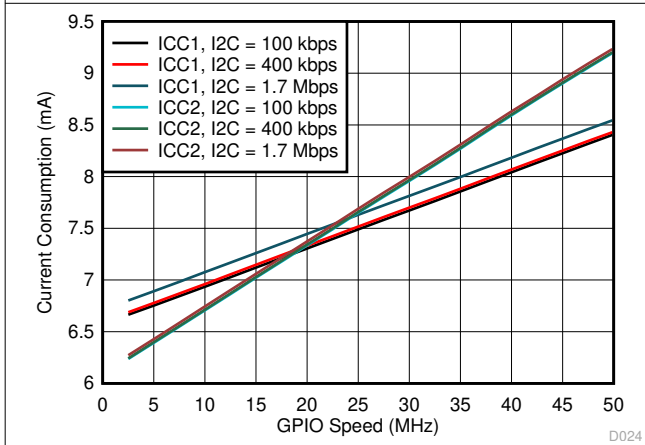

Figure 6-27. ISO1644: ICC vs GPIO Speed at 3.3V

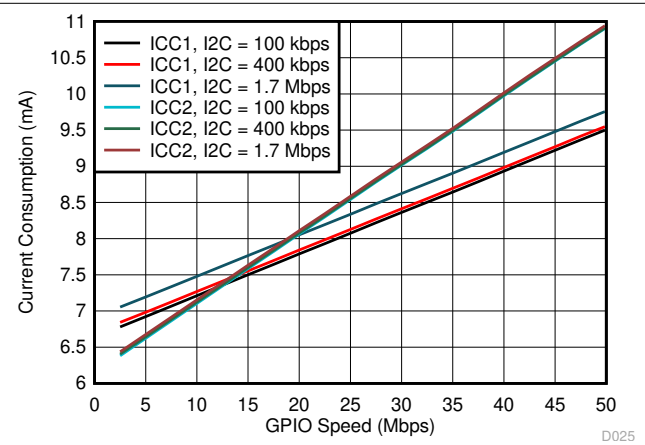

Figure 6-28. ISO1644: ICC vs GPIO Speed at 5V

7 Parameter Measurement Information

7.1 Parameter Measurement Information

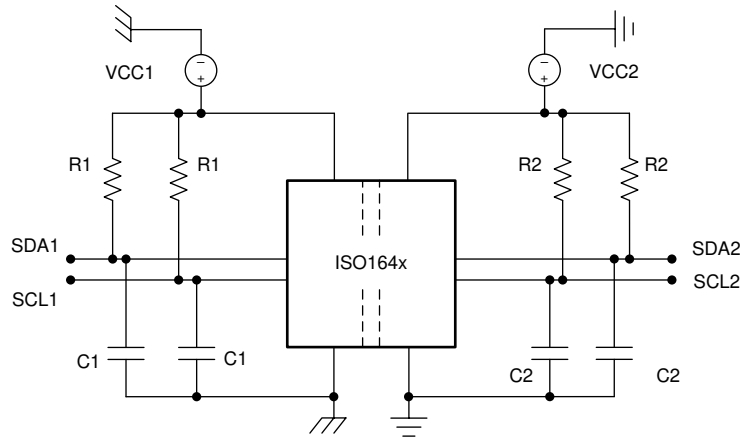

Figure 7-1. Test Diagram

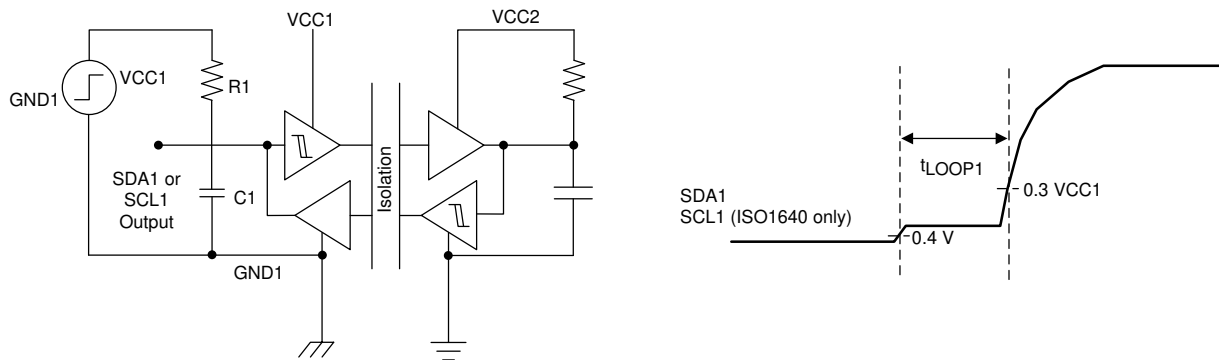

Figure 7-2. t_{Loop1} Setup and Timing Diagram

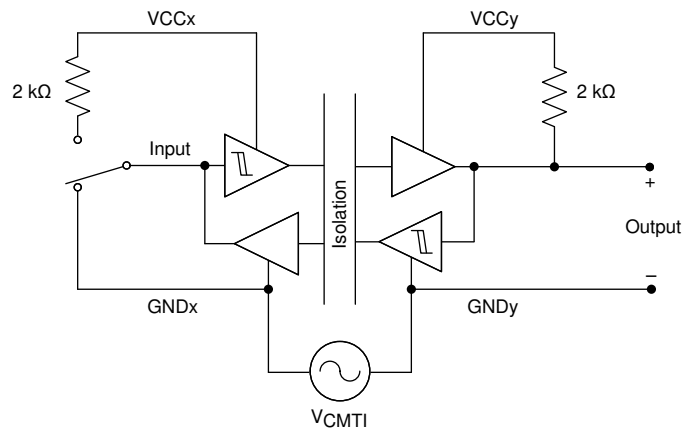
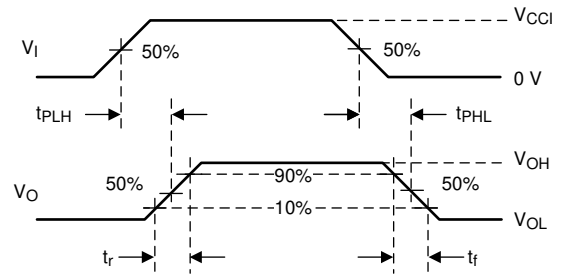
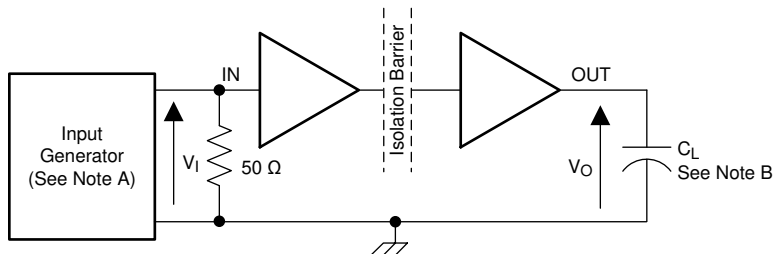
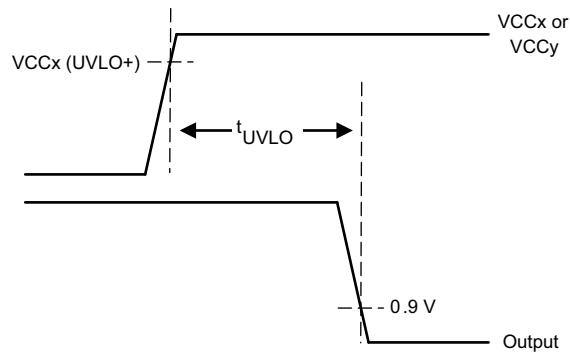
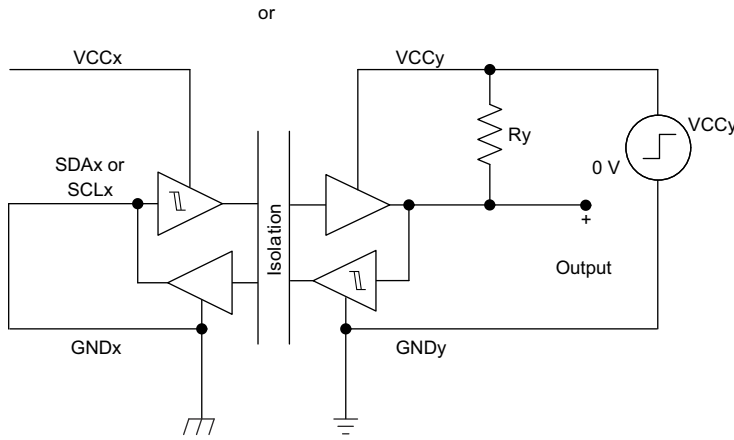
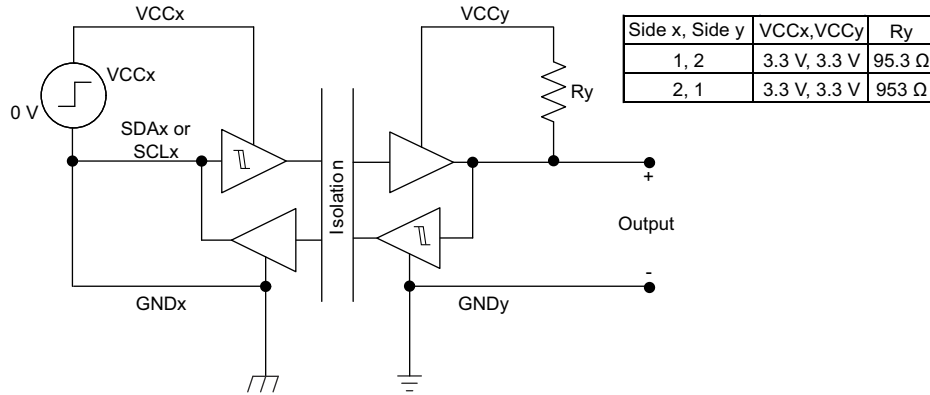

Figure 7-3. Common-Mode Transient Immunity Test Circuit



Copyright © 2016, Texas Instruments Incorporated

- A. The input pulse is supplied by a generator having the following characteristics: PRR \leq 50 kHz, 50% duty cycle, $t_r \leq$ 3 ns, $t_f \leq$ 3 ns, $Z_0 = 50 \Omega$. At the input, 50Ω resistor is required to terminate Input Generator signal. It is not needed in actual application.

- B. $C_L = 15$ pF and includes instrumentation and fixture capacitance within $\pm 20\%$.

Figure 7-4. GPIO Channel Switching Characteristics Test Circuit and Voltage Waveforms

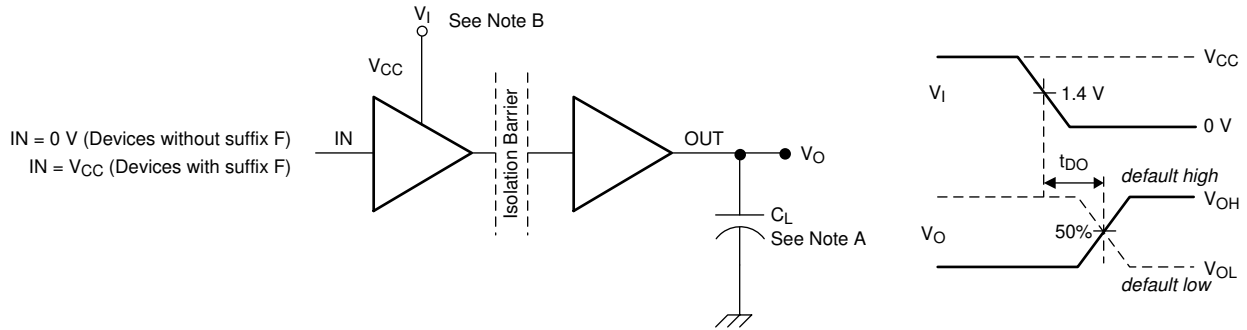

- A. $C_L = 15$ pF and includes instrumentation and fixture capacitance within $\pm 20\%$.
- B. Power Supply Ramp Rate = 10 mV/ns

Figure 7-5. GPIO Channel Default Output Delay Time Test Circuit and Voltage Waveforms

Figure 7-4. t_{UVLO} Test Circuit and Timing Diagrams

8 Detailed Description

8.1 Overview

The I²C bus consists of a two-wire communication bus that supports bidirectional data transfer between a master device and several slave devices. The master, or processor, controls the bus, specifically the serial clock (SCL) line. Data is transferred between the master and slave through a serial data (SDA) line. This data can be transferred in four speeds: standard mode (0 to 100 kbps), fast mode (0 to 400 kbps), fast-mode plus (0 to 1 Mbps), and high-speed mode (0 to 3.4 Mbps).

The I²C bus operates in bidirectional, half-duplex mode, using open collector outputs to allow for multiple devices to share the bus. When a specific device is ready to communicate on the bus, it can take control pulling the lines low accordingly in order to transmit data. A standard digital isolator or optocoupler is designed to transfer data in a single direction. In order to support an I²C bus, external circuitry is required to separate the bidirectional bus into two unidirectional signal paths. The ISO164x devices internally handle the separation and partitioning of the transmit and receive signals, integrating the external circuitry needed and provide the open-collector signals. They provide high electromagnetic immunity and low emissions at low power consumption. Each isolation channel has a logic input and output buffer separated by TI's double capacitive silicon dioxide (SiO₂) insulation barrier. When used in conjunction with isolated power supplies, these devices block high voltages, isolate grounds, and prevent noise currents from entering the local ground and interfering with or damaging sensitive circuitry.

8.2 Functional Block Diagrams

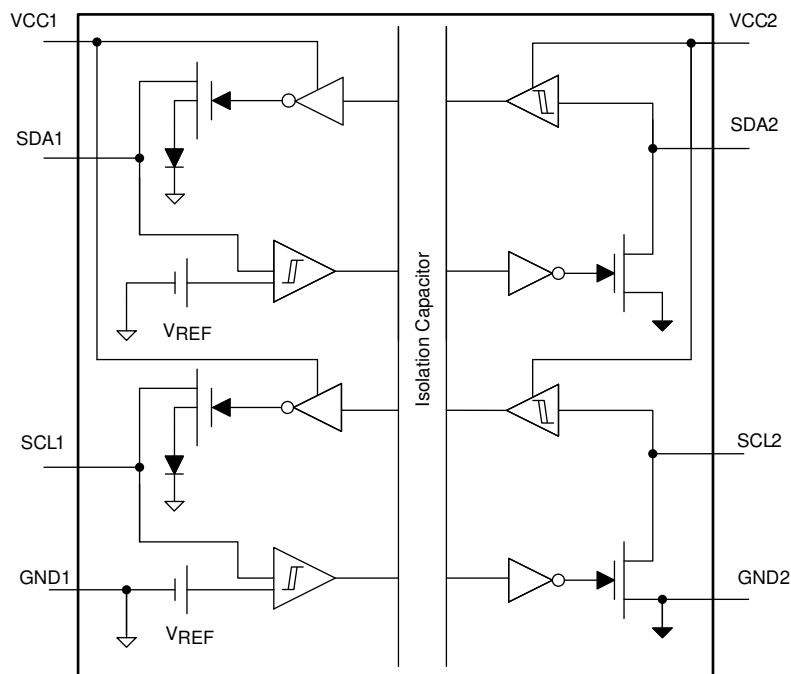

Figure 8-1. ISO1640 Block Diagram

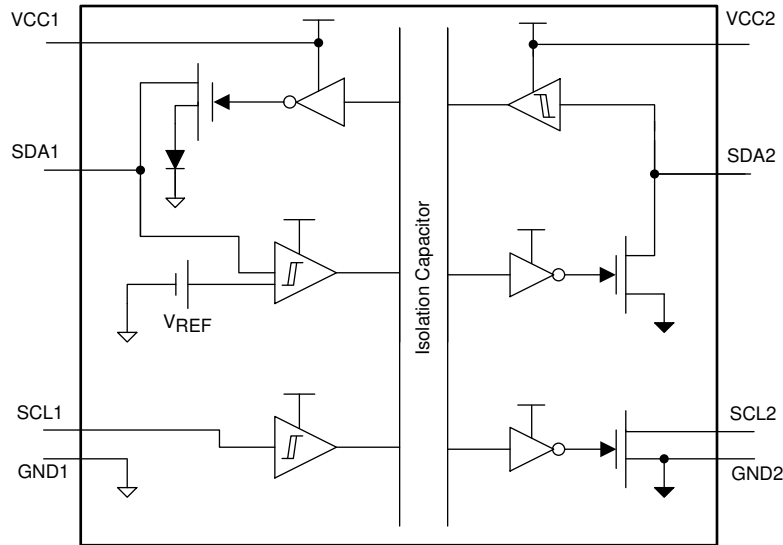

Figure 8-2. ISO1641 Block Diagram

8.3 Isolation Technology Overview

The ISO164x family of devices has an ON-OFF keying (OOK) modulation scheme to transmit the digital data across a silicon dioxide based isolation barrier. The transmitter sends a high frequency carrier across the barrier to represent one digital state and sends no signal to represent the other digital state. The receiver demodulates the signal after advanced signal conditioning and produces the output through a buffer stage. These devices also incorporate advanced circuit techniques to maximize the CMTI performance and minimize the radiated emissions due the high frequency carrier and switching.

8.4 Feature Description

The device enables a complete isolated I²C interface to be implemented within a small form factor having the features listed in [Table 8-1](#).

Table 8-1. Features List

PART NUMBER	CHANNEL DIRECTION	RATED ISOLATION ⁽¹⁾	I ² C MAXIMUM FREQUENCY	GPIO MAXIMUM FREQUENCY
ISO1640	Bidirectional SCL Bidirectional SDA	5000 V _{RMS} (16DW) 7071 V _{PK} (16DW) 3000 V _{RMS} (8D) 4242 V _{PK} (8D)	1.7 MHz	NA
ISO1641	Unidirectional (SCL) Bidirectional (SDA)	5000 V _{RMS} (16DW) 7071 V _{PK} (16DW) 3000 V _{RMS} (8D) 4242 V _{PK} (8D)		
ISO1642 ISO1643 ISO1644	Bidirectional SCL Bidirectional SDA	5000 V _{RMS} (16DW) 7071 V _{PK} (16DW)	1.7 MHz	50 Mbps

(1) See for detailed Isolation specifications.

8.4.1 Hot Swap

The ISO164x includes Hot Swap circuitry on Side 2 of the isolator to prevent loading on the I²C bus lines while VCC2 is either unpowered or in the process of being powered on. While VCC2 is below the UVLO threshold, the ISO164x bus lines will not load the bus to avoid disrupting or corrupting an active I²C bus. If the isolator is plugged into a live backplane using a staggered connector, where VCC2 and GND2 make connection first followed by the bus lines, the SDA and SCL lines are pre-charged to VCC2 / 2 to minimize the current required to charge the parasitic capacitance of the device. Once the device is fully powered on, the device bus pins become active providing bidirectional, isolated, SCL and SDA lines.

8.4.2 Protection Features

Features are integrated in the ISO164x to help protect the device from high current events. Enhanced ESD protection cells are designed on the I²C bus pins to support 10 kV HBM ESD on side 1 and 14 kV HBM ESD on side 2. The I²C bus pins on side 2 are designed to withstand an unpowered IEC-ESD strike of 8 kV, improving robustness and system reliability in hot swap applications. In addition to the improved ESD performance, a short circuit protection circuit is included on side 2 to protect the bus pins (SDA2 and SCL2) against strong short circuits of 5 ohms or less to VCC2.

Thermal shutdown is integrated in the ISO164x to protect the device from high current events. If the junction temperature of the device exceeds the thermal shutdown threshold of 190°C (typical), the device turns off, disabling the I²C circuits and releasing the bus. The shutdown condition is cleared when the junction temperature drops at least the thermal shutdown hysteresis temperature of 10°C (typical) below the thermal shutdown temperature of the device.

8.4.3 GPIO Channels

The ISO1642, ISO1643 and ISO1644 integrate unidirectional isolation channels, in addition to the bidirectional isolated I²C lines, to support system signals. The ISO1642 includes two channels in opposing directions (1/1 configuration) and the ISO1643 include two channels in the same direction (2/0 configuration). The ISO1644 includes three GPIO channels, two in one direction and one in the opposite direction (2/1 configuration) making it possible to use with a Serial Peripheral Interface (SPI). The conceptual block diagram of a unidirectional digital capacitive isolator channel is shown in [Figure 8-3](#).

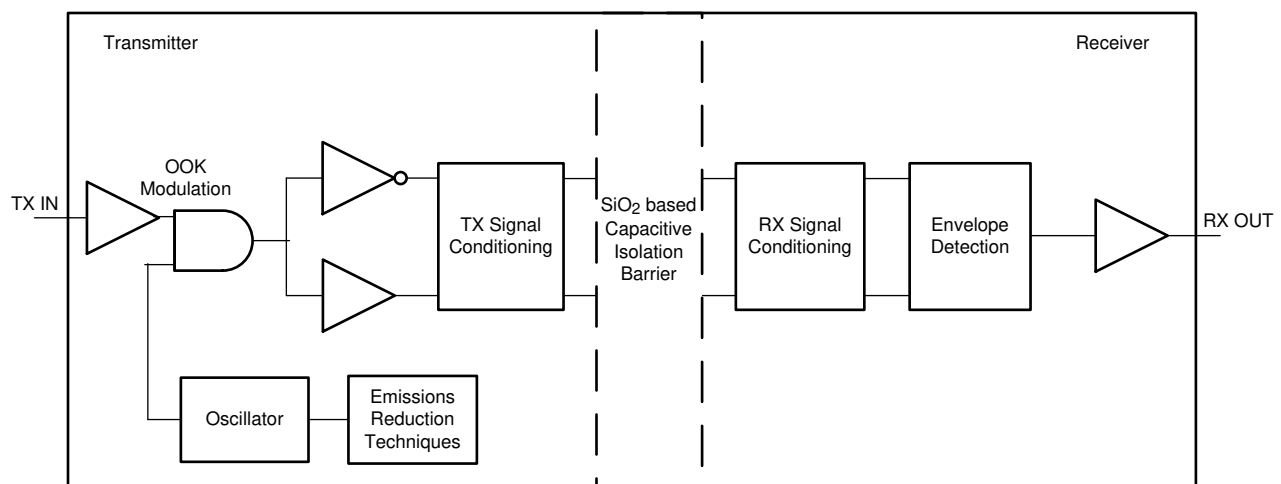

Figure 8-3. Conceptual Block Diagram of the GPIO Channels

8.5 Isolator Functional Principle

To isolate a bidirectional signal path (SDA or SCL), the ISO1640 internally splits a bidirectional line into two unidirectional signal lines, each of which is isolated through a single-channel digital isolator. Each channel output is made open-drain to comply with the open-drain technology of I²C. Side 1 of the ISO1640 connects to a low-capacitance I²C node (up to 80 pF), while side 2 is designed for connecting to a fully loaded I²C bus with up to 400 pF of capacitance.

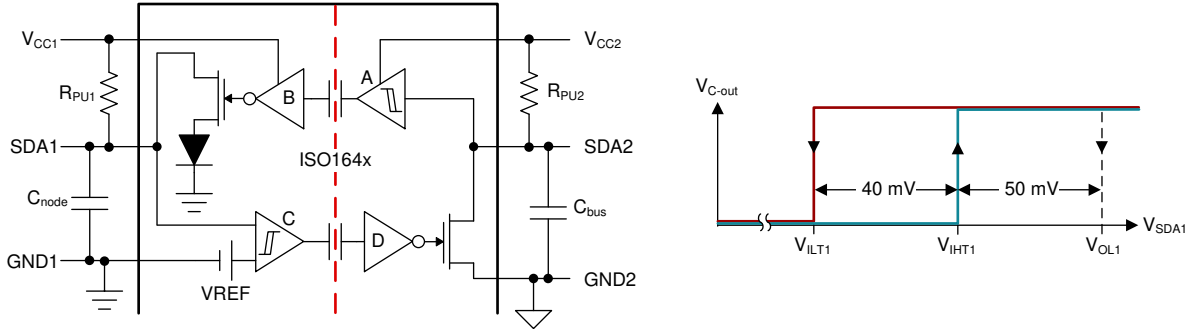

Figure 8-4. SDA Channel Design and Voltage Levels at SDA1

At first sight, the arrangement of the internal buffers suggests a closed signal loop that is prone to latch-up. However, this loop is broken by implementing an output buffer (B) whose output low-level is raised by a diode drop to approximately 0.65 V, and the input buffer (C) that consists of a comparator with defined hysteresis. The comparator's upper and lower input thresholds then distinguish between the proper low-potential of 0.4 V (maximum) driven directly by SDA1 and the buffered output low-level of B.

Figure 8-5 demonstrate the switching behavior of the I²C isolator, ISO164x, between a master node at SDA1 and a heavy loaded bus at SDA2.

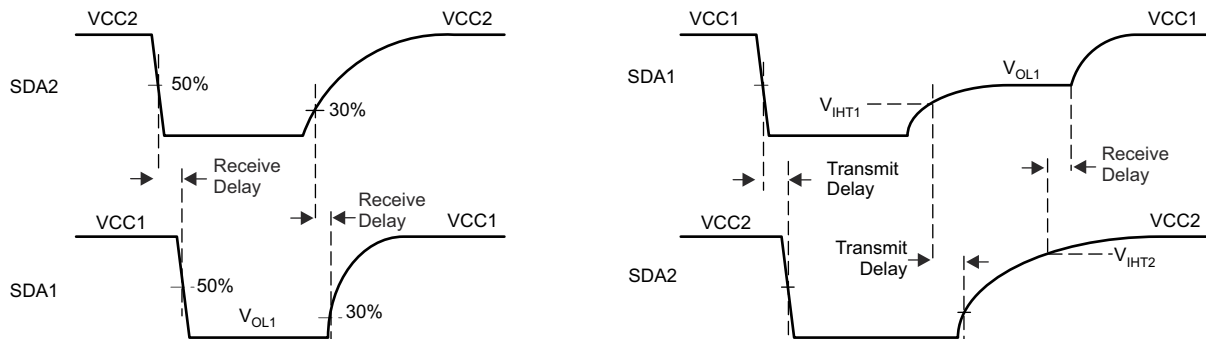

Figure 8-5. SDA Channel Timing in Receive and Transmit Directions

8.5.1 Receive Direction (Left Diagram of Figure 8-5)

When the I²C bus drives SDA2 low, SDA1 follows after a certain delay in the receive path. The output low is the buffered output of $V_{OL1} = 0.65\text{ V}$, which is sufficiently low to be detected by Schmitt-trigger inputs with a minimum input-low voltage of $V_{IL} = 0.9\text{ V}$ at 3 V supply levels.

When SDA2 is released, its voltage potential increases towards V_{CC2} following the time-constant formed by R_{PU2} and C_{bus} . After the receive delay, SDA1 is released and also rises towards V_{CC1} , following the time-constant $R_{PU1} \times C_{node}$. Because of the significant lower time-constant, SDA1 may reach V_{CC1} before SDA2 reaches V_{CC2} potential.

8.5.2 Transmit Direction (Right Diagram of Figure 8-5)

When a master drives SDA1 low, SDA2 follows after a certain delay in the transmit direction. When SDA2 turns low it also causes the output of buffer B to turn low but at a higher 0.65 V level. This level cannot be observed immediately as it is overwritten by the lower low-level of the master.

However, when the master releases SDA1, the voltage potential increases and first must pass the upper input threshold of the comparator, V_{IHT1} , to release SDA2. SDA1 then increases further until it reaches the buffered output level of $V_{OL1} = 0.65\text{ V}$, maintained by the receive path. When comparator C turns high, SDA2 is released after the delay in transmit direction. It takes another receive delay until B's output turns high and fully releases SDA1 to move toward V_{CC1} potential.

8.6 Device Functional Modes

Table 8-2 lists the ISO164x functional modes.

Table 8-2. I2C Function Table⁽¹⁾

POWER STATE	I2C INPUT	I2C OUTPUT
$V_{CC1} < 2.3\text{ V}$ or $V_{CC2} < 1.7\text{ V}$	X	Z
$V_{CC1} > 2.9\text{ V}$ and $V_{CC2} > 2.25\text{ V}$	L	L
$V_{CC1} > 2.9\text{ V}$ and $V_{CC2} > 2.25\text{ V}$	H	Z
$V_{CC1} > 2.9\text{ V}$ and $V_{CC2} > 2.25\text{ V}$	Z ⁽²⁾	Undetermined

- (1) H = High Level; L = Low Level; Z = High Impedance or Float; X = Irrelevant
 (2) Invalid input condition as an I²C system requires that a pullup resistor to VCC is connected.

Table 8-3. GPIO Function Table (ISO1642, ISO1643 and ISO1644 only)⁽¹⁾

V _{CCI}	V _{CCO}	GPIO INPUT (IN _x)	GPIO OUTPUT (OUT _x)	COMMENTS
PU	PU	H	H	Normal Operation: A channel output assumes the logic state of the input.
		L	L	
		Open	L	Default mode: When IN _x is open, the corresponding channel output goes to the default low logic state.
PD	PU	X	L	Default mode: When V _{CCI} is unpowered, a channel output assumes the low default logic state. When V _{CCI} transitions from unpowered to powered-up, a channel output assumes the logic state of the input. When V _{CCI} transitions from powered-up to unpowered, channel output assumes the low default state.
X	PD	X	Undetermined ⁽²⁾	When V _{CCO} is unpowered, a channel output is undetermined. When V _{CCO} transitions from unpowered to powered-up, a channel output assumes the logic state of the input

- (1) V_{CCI} = Input-side V_{CC}; V_{CCO} = Output-side V_{CC}; PU = Powered up ($V_{CC1} \geq 2.9\text{ V}$ or $V_{CC2} \geq 2.25\text{ V}$); PD = Powered down ($V_{CC1} \leq 2.3\text{ V}$ or $V_{CC2} \leq 1.7\text{ V}$); X = Irrelevant; H = High level; L = Low level
 (2) A strongly driven input signal can weakly power the floating V_{CC} via an internal protection diode and cause undetermined output.

9 Application and Implementation

Note

Information in the following applications sections is not part of the TI component specification, and TI does not warrant its accuracy or completeness. TI's customers are responsible for determining suitability of components for their purposes. Customers should validate and test their design implementation to confirm system functionality.

9.1 Application Information

9.1.1 I²C Bus Overview

The inter-integrated circuit (I²C) bus is a single-ended, multi-master, 2-wire bus for efficient inter-IC communication in half-duplex mode.

I²C uses open-drain technology, requiring two lines, serial data (SDA) and serial clock (SCL), to be connected to VDD by resistors (see Figure 9-1). Pulling the line to ground is considered a logic zero while letting the line float is a logic one. This logic is used as a channel access method. Transitions of logic states must occur while the SCL pin is low. Transitions while the SCL pin is high indicate START and STOP conditions. Typical supply voltages are 3.3 V and 5 V, although systems with higher or lower voltages are allowed.

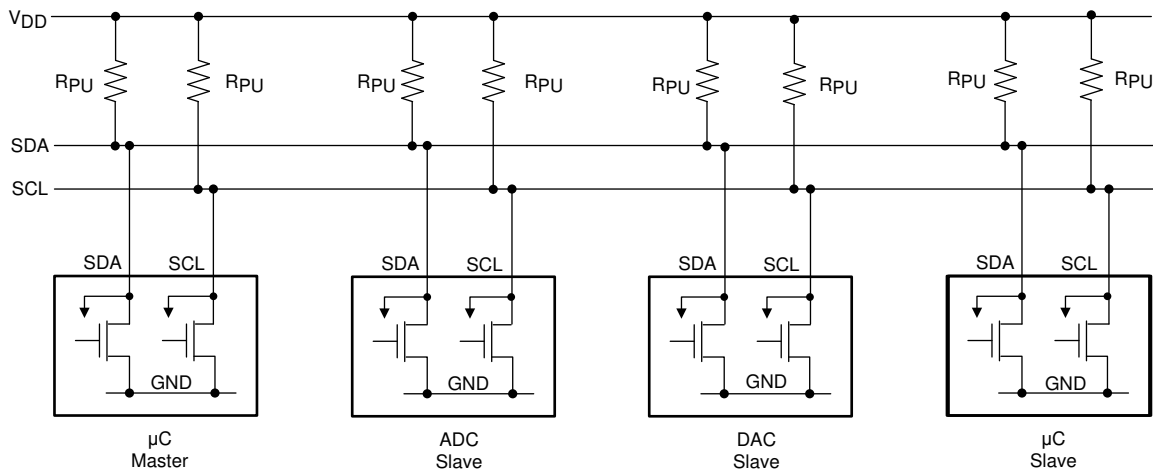

Figure 9-1. Example I²C Bus

I²C communication uses a 7-bit address space with 16 reserved addresses, so a theoretical maximum of 112 nodes can communicate on the same bus. In practice, however, the number of nodes is limited by the specified, total bus capacitance of 400 pF, which also restricts communication distances to a few meters.

The specified signaling rates for the ISO164x devices are 100 kbps (standard mode), 400 kbps (fast mode), 1.7 Mbps (fast mode plus).

The bus has two roles for nodes: master and slave. A master node issues the clock and slave addresses, and also initiates and ends data transactions. A slave node receives the clock and addresses and responds to requests from the master. Figure 9-2 shows a typical data transfer between master and slave.

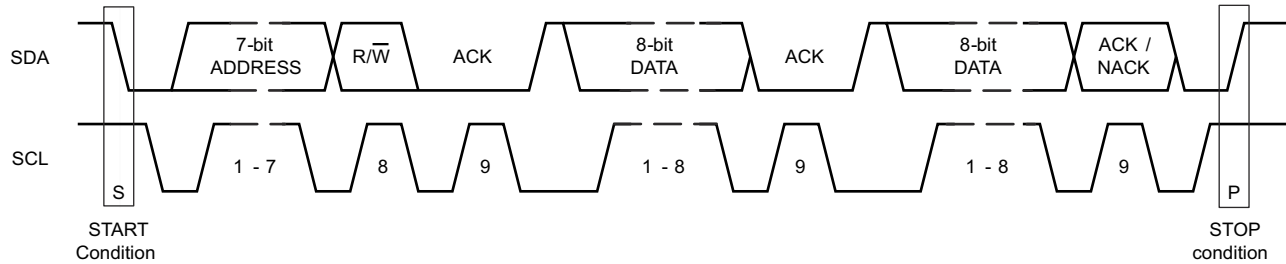

Figure 9-2. Timing Diagram of a Complete Data Transfer

The master initiates a transaction by creating a START condition, following by the 7-bit address of the slave it wishes to communicate with. This is followed by a single read and write (R/W) bit, representing whether the master wishes to write to (0), or to read from (1) the slave. The master then releases the SDA line to allow the slave to acknowledge the receipt of data.

The slave responds with an acknowledge bit (ACK) by pulling the SDA pin low during the entire high time of the 9th clock pulse on the SCL signal, after which the master continues in either transmit or receive mode (according to the R/W bit sent), while the slave continues in the complementary mode (receive or transmit, respectively).

The address and the 8-bit data bytes are sent most significant bit (MSB) first. The START bit is indicated by a high-to-low transition of SDA while SCL is high. The STOP condition is created by a low-to-high transition of SDA while SCL is high.

If the master writes to a slave, it repeatedly sends a byte with the slave sending an ACK bit. In this case, the master is in master-transmit mode and the slave is in slave-receive mode.

If the master reads from a slave, it repeatedly receives a byte from the slave, while acknowledging (ACK) the receipt of every byte but the last one (see [Figure 9-3](#)). In this situation, the master is in master-receive mode and the slave is in slave-transmit mode.

The master ends the transmission with a STOP bit, or may send another START bit to maintain bus control for further transfers.

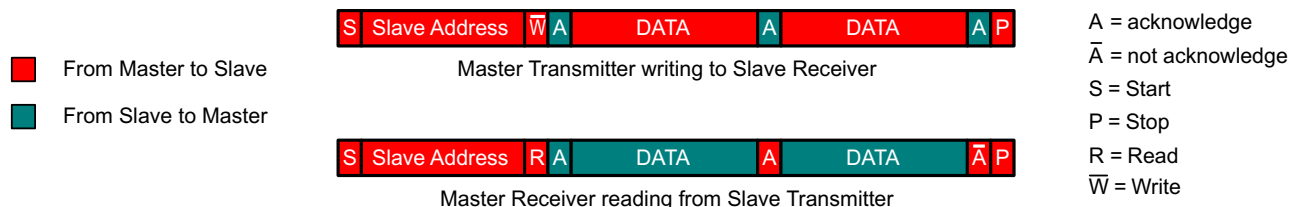

Figure 9-3. Transmit or Receive Mode Changes During a Data Transfer

When writing to a slave, a master mainly operates in transmit-mode and only changes to receive-mode when receiving acknowledgment from the slave.

When reading from a slave, the master starts in transmit-mode and then changes to receive-mode after sending a READ request (R/W bit = 1) to the slave. The slave continues in the complementary mode until the end of a transaction.

Note

The master ends a reading sequence by not acknowledging (NACK) the last byte received. This procedure resets the slave state machine and allows the master to send the STOP command.

9.2 Typical Application

In [Figure 9-4](#), the ultra low-power microcontroller, MSP430G2132, controls the I²C data traffic of configuration data and conversion results for the analog inputs and outputs. In [Figure 9-5](#), the TMS320F28035 controls both

the I²C interface, for communication to a DAC for analog outputs, and a SPI interface, for communication to an ADC for analog inputs.

Low-power data converters build the analog interface to sensors and actuators. The ISO164x device provides the required isolation between different ground potentials of the system controller, remote sensor, and actuator circuitry to prevent ground loop currents that otherwise may falsify the acquired data.

The entire circuit operates from a single 3.3-V supply. A low-power push-pull converter, SN6501, drives a center-tapped transformer with an output that is rectified and linearly regulated to provide a stable 5-V supply for the data converters.

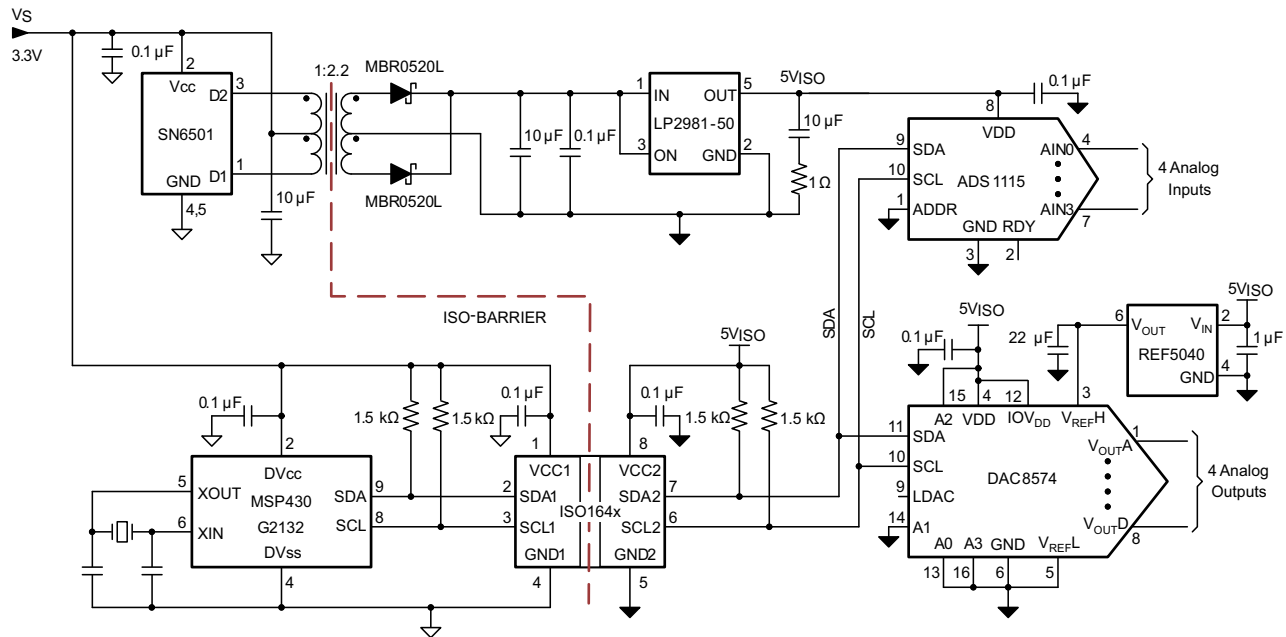

Figure 9-4. Isolated I²C Data Acquisition System

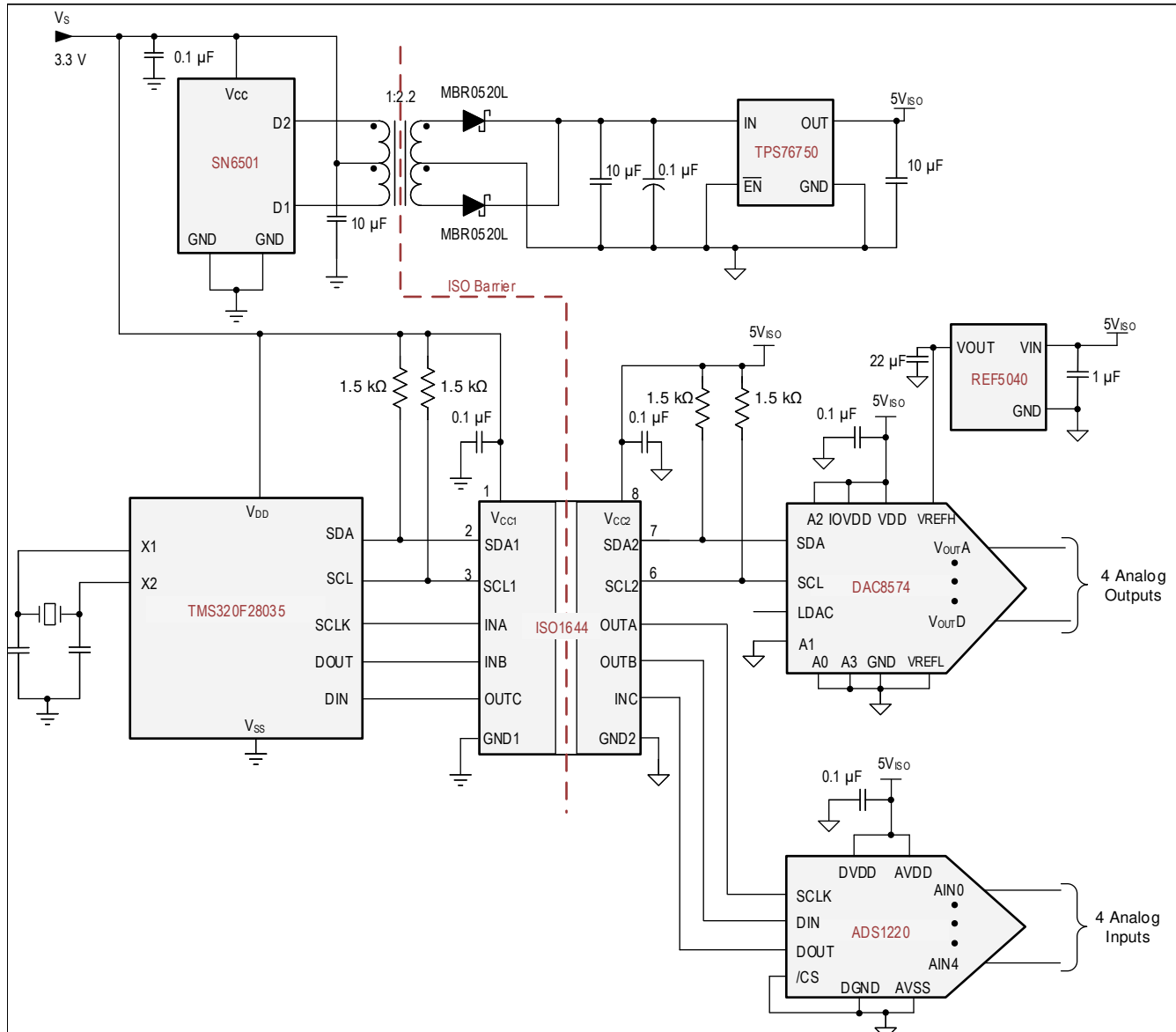

Figure 9-5. Isolated I²C and SPI Data Acquisition System

9.2.1 Design Requirements

The recommended power supply voltages must be from 3 V to 5.5 V for VCC1 and 2.25 V to 5.5 V for VCC2. A recommended decoupling capacitor with a value of 0.1 μ F is required between both the VCC1 and GND1 pins, and the VCC2 and GND2 pins to support of power supply voltage transients and to ensure reliable operation at all data rates.

9.2.2 Detailed Design Procedure

Although the ISO1640 features bidirectional data channels, the device performs optimally when side 1 (SDA1 and SCL1) is connected to a single controller or node of an I²C network while side 2 (SDA2 and SCL2) is connected to the I²C bus. The maximum load permissible on the input lines, SDA1 and SCL1, is ≤ 80 pF and on the output lines, SDA2 and SCL2, is ≤ 400 pF. In addition to the bidirectional data and clock channels for the I²C network, the ISO1644 includes 3 GPIOs which can be used for static I/O lines or for a 3 wire SPI interface. These lines are designed to support up to 50 Mbps data transfer rate.

The power-supply capacitor with a value of 0.1- μF must be placed as close to the power supply pins as possible. The recommended placement of the capacitors must be 2-mm maximum from input and output power supply pins (VCC1 and VCC2).

The minimum pullup resistors on the input lines, SDA1 and SCL1 to VCC1 must be selected in such a way that input current drawn is ≤ 3.5 mA. The minimum pullup resistors on the input lines, SDA2 and SCL2, to VCC2 must be selected in such a way that output current drawn is ≤ 50 mA. The maximum pullup resistors on the bus lines (SDA1 and SCL1) to VCC1 and on bus lines (SDA2 and SCL2) to VCC2, depends on the load and rise time requirements on the respective lines to comply with I2C protocols. For more information, see [I2C Bus Pullup Resistor Calculation](#).

The output waveforms for SDA1 and SCL1 are captured on the oscilloscope focusing on the low V_{OL1} voltage offset offered with the ISO164x. This voltage offset is due to the output low level on side 1 designed to prevent a latch-up state mentioned in [Section 8.5](#).

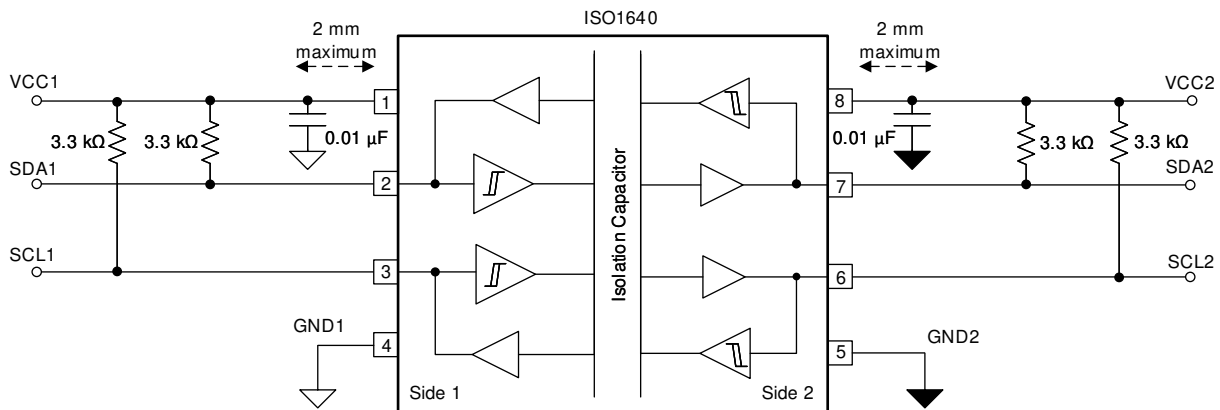

Figure 9-6. Typical ISO1640 Circuit Hookup

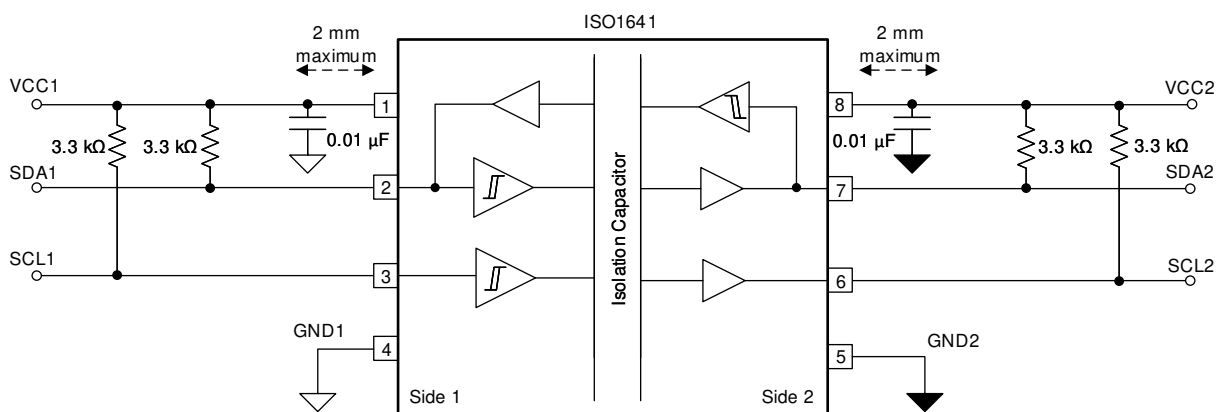

Figure 9-7. Typical ISO1641 Circuit Hookup

9.2.3 Application Curve

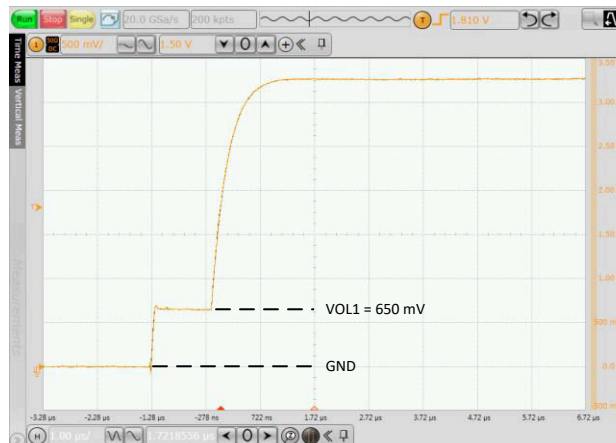

Figure 9-8. Side 1 ISO1640: Low-to-High Transition



Figure 9-9. Side 1 ISO1644: Low-to-High Transition With Toggling GPIO lines

9.3 Insulation Lifetime

Insulation lifetime projection data is collected by using the industry-standard Time Dependent Dielectric Breakdown (TDDB) test method. In this test, all pins on each side of the barrier are tied together creating a two-terminal device and high voltage is applied between the two sides; see [Figure 9-10](#) for TDDB test setup. The insulation breakdown data is collected at various high voltages switching at 60 Hz over temperature. For basic insulation, VDE standard requires the use of a TDDB projection line with failure rate of less than 1000 part per million (ppm). For reinforced insulation, VDE standard requires the use of a TDDB projection line with failure rate of less than 1 part per million (ppm).

Even though the expected minimum insulation lifetime is 20 years, at the specified working isolation voltage, VDE basic and reinforced certifications require additional safety margin of 20% for working voltage. For basic certification, device lifetime requires a safety margin of 30% translating to a minimum required insulation lifetime of 26 years at a working voltage that is 20% higher than the specified value. For reinforced insulation, device lifetime requires a safety margin of 87.5% translating to a minimum required insulation lifetime of 37.5 years at a working voltage that is 20% higher than the specified value.

[Insulation Lifetime Projection Data for ISO164x in 8-D Package](#) and [Insulation Lifetime Projection Data for ISO164x in 16-DW Package](#) show the intrinsic capability of the isolation barrier to withstand high voltage stress over its lifetime. Based on the TDDB data, the intrinsic capability of the insulation is 450 V_{RMS} with a lifetime in excess of 100 years in the 8-D package and 1500 V_{RMS} with a lifetime in excess of 135 years in the 16-DW package. Other factors, such as package size, pollution degree, material group, etc. can further limit the working voltage of the component. At the lower working voltages, the corresponding insulation lifetime is much longer than 100 years in the 8-D package and 135 years in the 16-DW package.

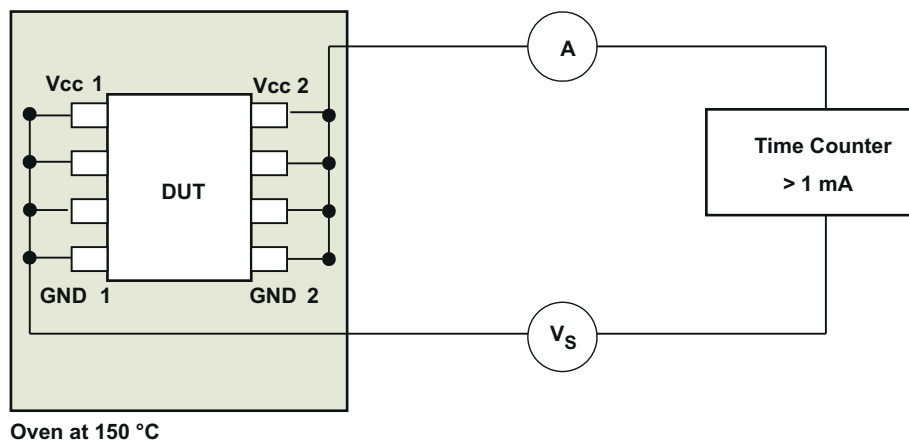

Figure 9-10. Test Setup for Insulation Lifetime Measurement

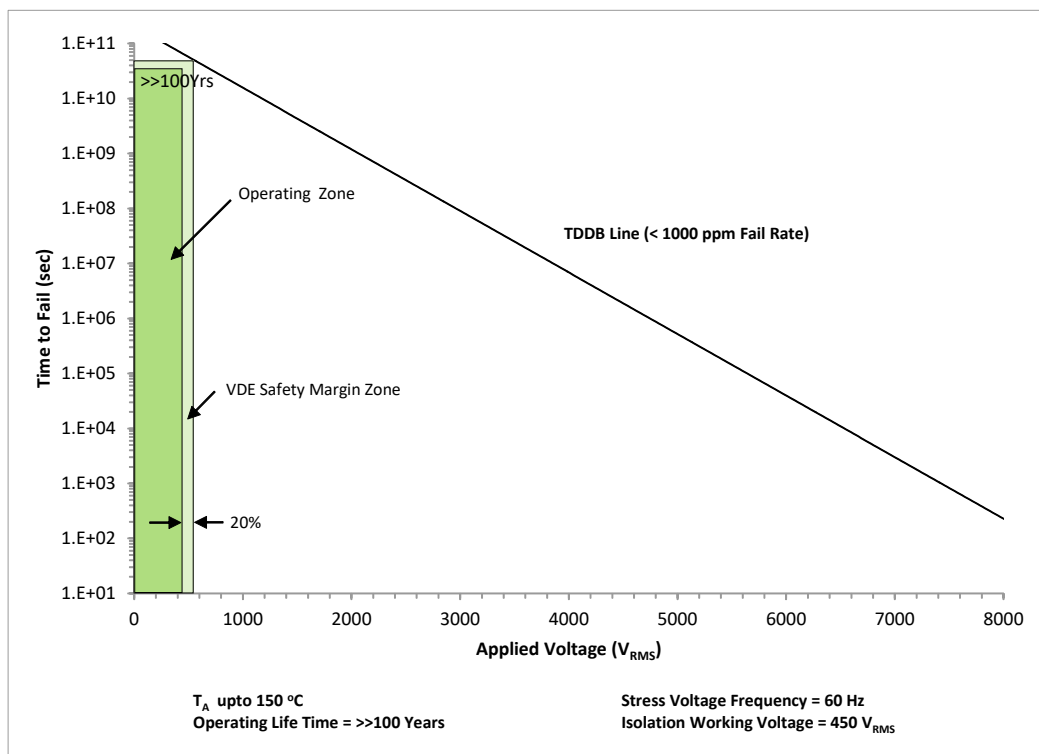

Figure 9-11. Insulation Lifetime Projection Data for ISO164x in 8-D Package

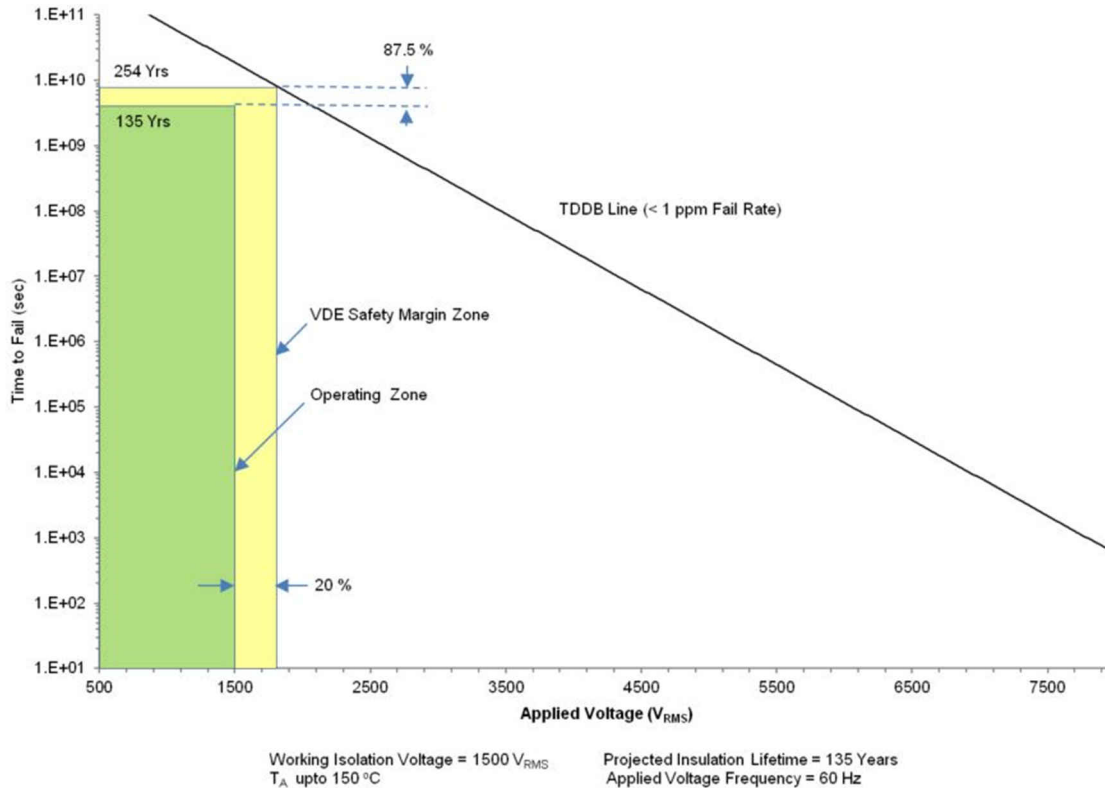

Figure 9-12. Insulation Lifetime Projection Data for ISO164x in 16-DW Package

10 Power Supply Recommendations

To help ensure reliable operation at data rates and supply voltages, TI recommends connecting a 0.1- μ F bypass capacitor at the input and output supply pins (VCC1 and VCC2). The capacitors should be placed as close to the supply pins as possible. If only a single, primary-side power supply is available in an application, isolated power can be generated for the secondary-side with the help of a transformer driver such as TI's [SN6501](#) device. For such applications, detailed power supply design and transformer selection recommendations are available in [SN6501 Transformer Driver for Isolated Power Supplies](#). (SLLSEA0).

11 Layout

11.1 Layout Guidelines

A minimum of four layers is required to accomplish a low EMI PCB design (see [Figure 11-1](#)). Layer stacking should be in the following order (top-to-bottom): high-speed signal layer, ground plane, power plane and low-frequency signal layer.

- Routing the high-speed traces on the top layer avoids the use of vias (and the introduction of their inductances) and allows for clean interconnects between the isolator and the transmitter and receiver circuits of the data link.
- Placing a solid ground plane next to the high-speed signal layer establishes controlled impedance for transmission line interconnects and provides an excellent low-inductance path for the return current flow.
- Placing the power plane next to the ground plane creates additional high-frequency bypass capacitance of approximately 100 pF/in².
- Routing the slower speed control signals on the bottom layer allows for greater flexibility as these signal links usually have margin to tolerate discontinuities such as vias.

If an additional supply voltage plane or signal layer is needed, add a second power or ground plane system to the stack to keep it symmetrical. This makes the stack mechanically stable and prevents it from warping. Also the power and ground plane of each power system can be placed closer together, thus increasing the high-frequency bypass capacitance significantly.

For detailed layout recommendations, see the [Digital Isolator Design Guide](#) (SLLA284)

11.1.1 PCB Material

For digital circuit boards operating at less than 150 Mbps, (or rise and fall times greater than 1 ns), and trace lengths of up to 10 inches, use standard FR-4 UL94V-0 printed circuit board. This PCB is preferred over cheaper alternatives because of lower dielectric losses at high frequencies, less moisture absorption, greater strength and stiffness, and the self-extinguishing flammability-characteristics.

11.2 Layout Example

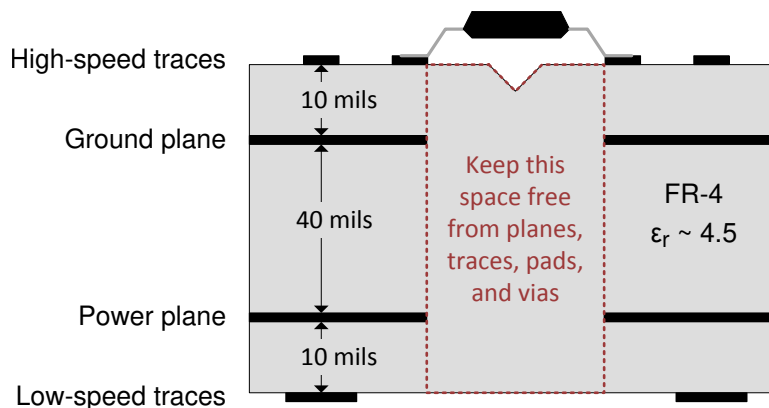

Figure 11-1. Recommended Layer Stack

12 Device and Documentation Support

12.1 Documentation Support

12.1.1 Related Documentation

For related documentation see the following:

- Texas Instruments, [How Do Isolated I2C Buffers with Hot-Swap Capability and IEC ESD Improve Isolated I2C?](#)
- Texas Instruments, [Digital Isolator Design Guide](#)
- Texas Instruments, [How to use isolation to improve ESD, EFT and Surge immunity in industrial systems application report](#)
- Texas Instruments, [Isolation Glossary](#)
- Texas Instruments, [What is EMC? 4 questions about EMI, radiated emissions, ESD and EFT in isolated systems](#)
- Texas Instruments, [SN6501 Transformer Driver for Isolated Power Supplies data sheet](#)
- Texas Instruments, [SN6505x Transformer Driver for Isolated Power Supplies data sheet](#)
- Texas Instruments, [I2C Bus Pullup Resistor Calculation](#)
- Texas Instruments, [ISO1640DEVM Evaluation Module Users Guide](#)

12.2 Receiving Notification of Documentation Updates

To receive notification of documentation updates, navigate to the device product folder on [ti.com](#). Click on *Subscribe to updates* to register and receive a weekly digest of any product information that has changed. For change details, review the revision history included in any revised document.

12.3 Support Resources

[TI E2E™ support forums](#) are an engineer's go-to source for fast, verified answers and design help — straight from the experts. Search existing answers or ask your own question to get the quick design help you need.

Linked content is provided "AS IS" by the respective contributors. They do not constitute TI specifications and do not necessarily reflect TI's views; see TI's [Terms of Use](#).

12.4 Trademarks

TI E2E™ is a trademark of Texas Instruments.
All trademarks are the property of their respective owners.

12.5 Electrostatic Discharge Caution



This integrated circuit can be damaged by ESD. Texas Instruments recommends that all integrated circuits be handled with appropriate precautions. Failure to observe proper handling and installation procedures can cause damage.

ESD damage can range from subtle performance degradation to complete device failure. Precision integrated circuits may be more susceptible to damage because very small parametric changes could cause the device not to meet its published specifications.

12.6 Glossary

[TI Glossary](#) This glossary lists and explains terms, acronyms, and definitions.

13 Mechanical, Packaging, and Orderable Information

The following pages include mechanical packaging and orderable information. This information is the most current data available for the designated devices. This data is subject to change without notice and revision of this document. For browser-based versions of this data sheet, refer to the left-hand navigation.

PACKAGING INFORMATION

Orderable Device	Status (1)	Package Type	Package Drawing	Pins	Package Qty	Eco Plan (2)	Lead finish/ Ball material (6)	MSL Peak Temp (3)	Op Temp (°C)	Device Marking (4/5)	Samples
ISO1640BDR	ACTIVE	SOIC	D	8	3000	RoHS & Green	NIPDAU	Level-2-260C-1 YEAR	-40 to 125	1640B	Samples
ISO1640DWR	ACTIVE	SOIC	DW	16	2000	RoHS & Green	NIPDAU	Level-2-260C-1 YEAR	-40 to 125	ISO1640	Samples
ISO1641BDR	ACTIVE	SOIC	D	8	3000	RoHS & Green	NIPDAU	Level-2-260C-1 YEAR	-40 to 125	1641B	Samples
ISO1641DWR	ACTIVE	SOIC	DW	16	2000	RoHS & Green	NIPDAU	Level-2-260C-1 YEAR	-40 to 125	ISO1641	Samples
ISO1642DWR	ACTIVE	SOIC	DW	16	2000	RoHS & Green	NIPDAU	Level-2-260C-1 YEAR	-40 to 125	ISO1642	Samples
ISO1643DWR	ACTIVE	SOIC	DW	16	2000	RoHS & Green	NIPDAU	Level-2-260C-1 YEAR	-40 to 125	ISO1643	Samples
ISO1644DWR	ACTIVE	SOIC	DW	16	2000	RoHS & Green	NIPDAU	Level-2-260C-1 YEAR	-40 to 125	ISO1644	Samples

(1) The marketing status values are defined as follows:

ACTIVE: Product device recommended for new designs.

LIFEBUY: TI has announced that the device will be discontinued, and a lifetime-buy period is in effect.

NRND: Not recommended for new designs. Device is in production to support existing customers, but TI does not recommend using this part in a new design.

PREVIEW: Device has been announced but is not in production. Samples may or may not be available.

OBSOLETE: TI has discontinued the production of the device.

(2) **RoHS:** TI defines "RoHS" to mean semiconductor products that are compliant with the current EU RoHS requirements for all 10 RoHS substances, including the requirement that RoHS substance do not exceed 0.1% by weight in homogeneous materials. Where designed to be soldered at high temperatures, "RoHS" products are suitable for use in specified lead-free processes. TI may reference these types of products as "Pb-Free".

RoHS Exempt: TI defines "RoHS Exempt" to mean products that contain lead but are compliant with EU RoHS pursuant to a specific EU RoHS exemption.

Green: TI defines "Green" to mean the content of Chlorine (Cl) and Bromine (Br) based flame retardants meet JS709B low halogen requirements of <=1000ppm threshold. Antimony trioxide based flame retardants must also meet the <=1000ppm threshold requirement.

(3) MSL, Peak Temp. - The Moisture Sensitivity Level rating according to the JEDEC industry standard classifications, and peak solder temperature.

(4) There may be additional marking, which relates to the logo, the lot trace code information, or the environmental category on the device.

(5) Multiple Device Markings will be inside parentheses. Only one Device Marking contained in parentheses and separated by a "~" will appear on a device. If a line is indented then it is a continuation of the previous line and the two combined represent the entire Device Marking for that device.

⁽⁶⁾ Lead finish/Ball material - Orderable Devices may have multiple material finish options. Finish options are separated by a vertical ruled line. Lead finish/Ball material values may wrap to two lines if the finish value exceeds the maximum column width.

Important Information and Disclaimer:The information provided on this page represents TI's knowledge and belief as of the date that it is provided. TI bases its knowledge and belief on information provided by third parties, and makes no representation or warranty as to the accuracy of such information. Efforts are underway to better integrate information from third parties. TI has taken and continues to take reasonable steps to provide representative and accurate information but may not have conducted destructive testing or chemical analysis on incoming materials and chemicals. TI and TI suppliers consider certain information to be proprietary, and thus CAS numbers and other limited information may not be available for release.

In no event shall TI's liability arising out of such information exceed the total purchase price of the TI part(s) at issue in this document sold by TI to Customer on an annual basis.

OTHER QUALIFIED VERSIONS OF ISO1640 :

- Automotive : [ISO1640-Q1](#)

NOTE: Qualified Version Definitions:

- Automotive - Q100 devices qualified for high-reliability automotive applications targeting zero defects

TAPE AND REEL INFORMATION

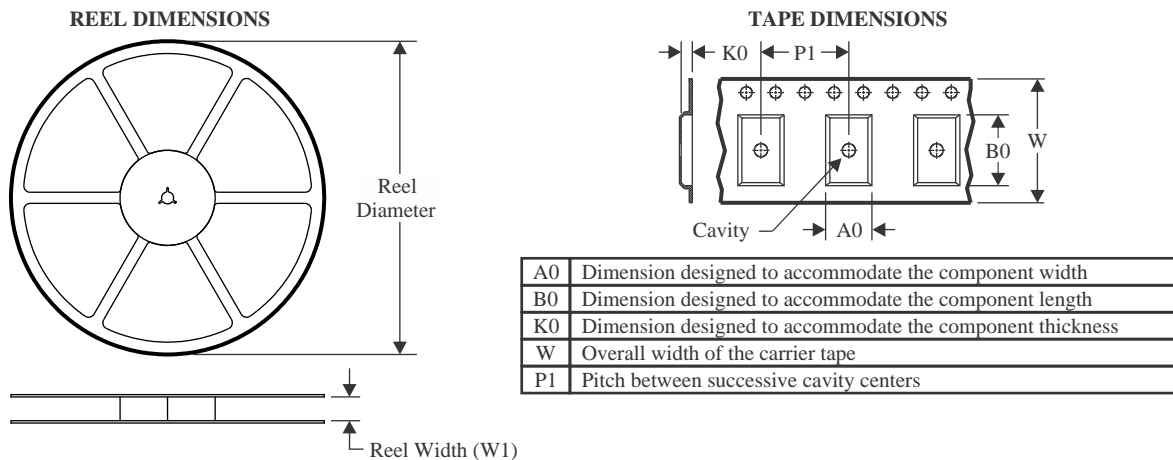

QUADRANT ASSIGNMENTS FOR PIN 1 ORIENTATION IN TAPE

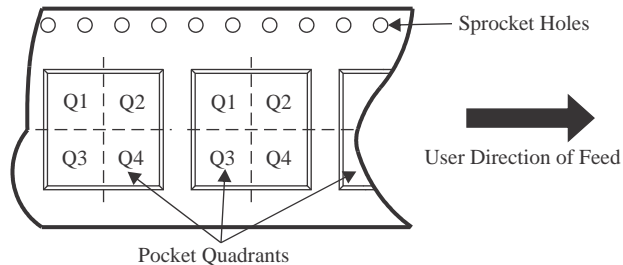

*All dimensions are nominal

Device	Package Type	Package Drawing	Pins	SPQ	Reel Diameter (mm)	Reel Width W1 (mm)	A0 (mm)	B0 (mm)	K0 (mm)	P1 (mm)	W (mm)	Pin1 Quadrant
ISO1640BDR	SOIC	D	8	3000	330.0	12.4	6.4	5.2	2.1	8.0	12.0	Q1
ISO1640DWR	SOIC	DW	16	2000	330.0	16.4	10.75	10.7	2.7	12.0	16.0	Q1
ISO1640DWR	SOIC	DW	16	2000	330.0	16.4	10.75	10.7	2.7	12.0	16.0	Q1
ISO1641BDR	SOIC	D	8	3000	330.0	12.4	6.4	5.2	2.1	8.0	12.0	Q1
ISO1641BDR	SOIC	D	8	3000	330.0	12.4	6.4	5.2	2.1	8.0	12.0	Q1
ISO1641DWR	SOIC	DW	16	2000	330.0	16.4	10.75	10.7	2.7	12.0	16.0	Q1
ISO1642DWR	SOIC	DW	16	2000	330.0	16.4	10.75	10.7	2.7	12.0	16.0	Q1
ISO1642DWR	SOIC	DW	16	2000	330.0	16.4	10.75	10.7	2.7	12.0	16.0	Q1
ISO1642DWR	SOIC	DW	16	2000	330.0	16.4	10.75	10.7	2.7	12.0	16.0	Q1
ISO1643DWR	SOIC	DW	16	2000	330.0	16.4	10.75	10.7	2.7	12.0	16.0	Q1
ISO1644DWR	SOIC	DW	16	2000	330.0	16.4	10.75	10.7	2.7	12.0	16.0	Q1
ISO1644DWR	SOIC	DW	16	2000	330.0	16.4	10.75	10.7	2.7	12.0	16.0	Q1

TAPE AND REEL BOX DIMENSIONS

*All dimensions are nominal

Device	Package Type	Package Drawing	Pins	SPQ	Length (mm)	Width (mm)	Height (mm)
ISO1640BDR	SOIC	D	8	3000	356.0	356.0	35.0
ISO1640DWR	SOIC	DW	16	2000	356.0	356.0	35.0
ISO1640DWR	SOIC	DW	16	2000	353.0	353.0	32.0
ISO1641BDR	SOIC	D	8	3000	356.0	356.0	35.0
ISO1641BDR	SOIC	D	8	3000	356.0	356.0	35.0
ISO1641DWR	SOIC	DW	16	2000	356.0	356.0	35.0
ISO1642DWR	SOIC	DW	16	2000	356.0	356.0	35.0
ISO1642DWR	SOIC	DW	16	2000	356.0	356.0	35.0
ISO1643DWR	SOIC	DW	16	2000	356.0	356.0	35.0
ISO1644DWR	SOIC	DW	16	2000	356.0	356.0	35.0
ISO1644DWR	SOIC	DW	16	2000	356.0	356.0	35.0

GENERIC PACKAGE VIEW

DW 16

SOIC - 2.65 mm max height

7.5 x 10.3, 1.27 mm pitch

SMALL OUTLINE INTEGRATED CIRCUIT

This image is a representation of the package family, actual package may vary.
Refer to the product data sheet for package details.

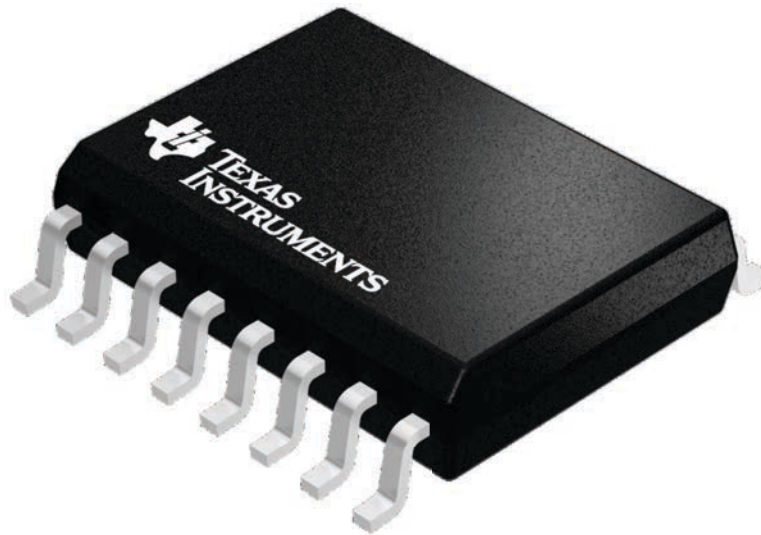

4224780/A

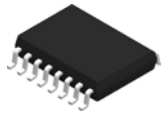

DW0016B

PACKAGE OUTLINE SOIC - 2.65 mm max height

SOIC

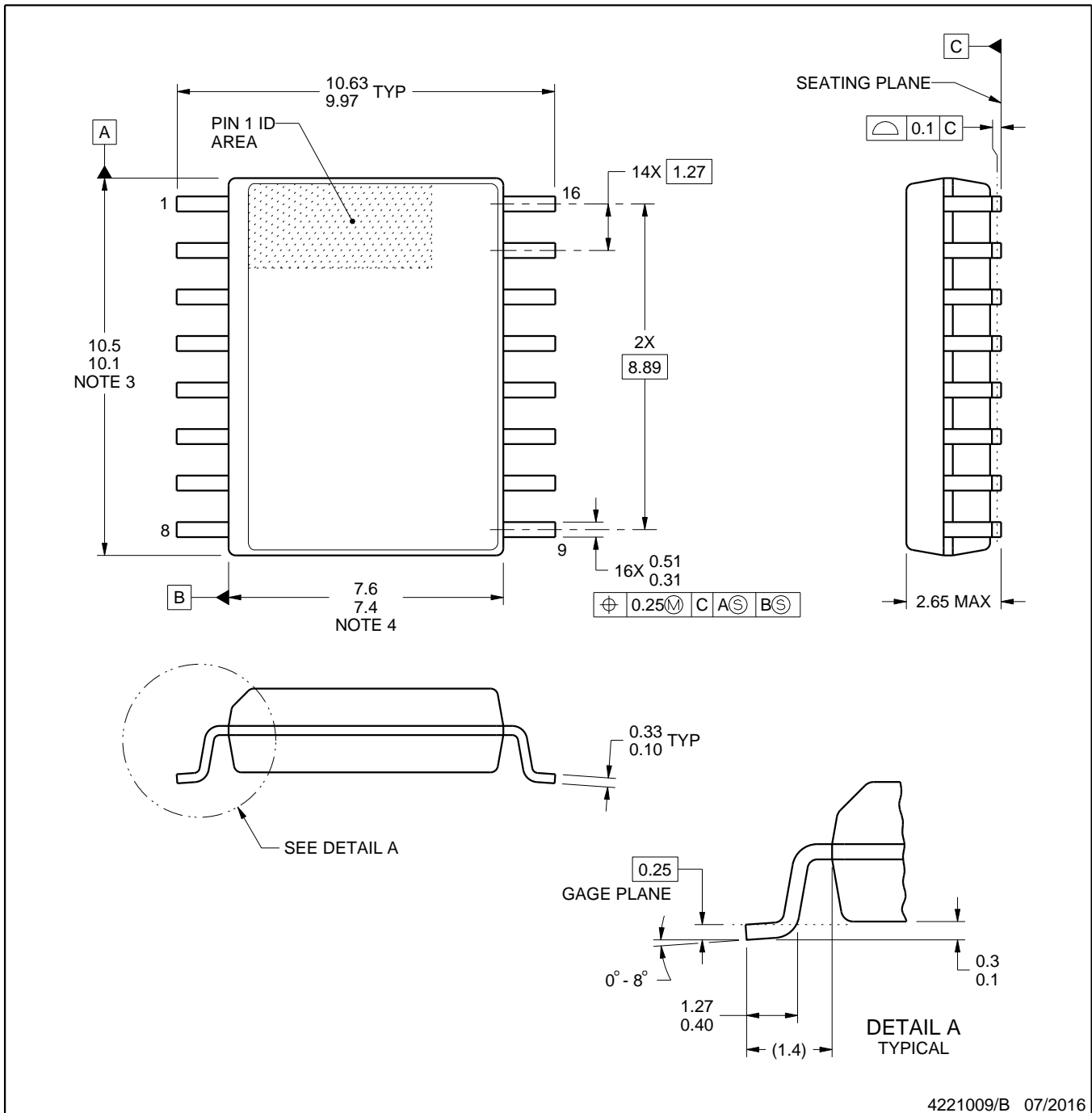

4221009/B 07/2016

NOTES:

1. All linear dimensions are in millimeters. Dimensions in parenthesis are for reference only. Dimensioning and tolerancing per ASME Y14.5M.
2. This drawing is subject to change without notice.
3. This dimension does not include mold flash, protrusions, or gate burrs. Mold flash, protrusions, or gate burrs shall not exceed 0.15 mm, per side.
4. This dimension does not include interlead flash. Interlead flash shall not exceed 0.25 mm, per side.
5. Reference JEDEC registration MS-013.

EXAMPLE BOARD LAYOUT

DW0016B

SOIC - 2.65 mm max height

SOIC

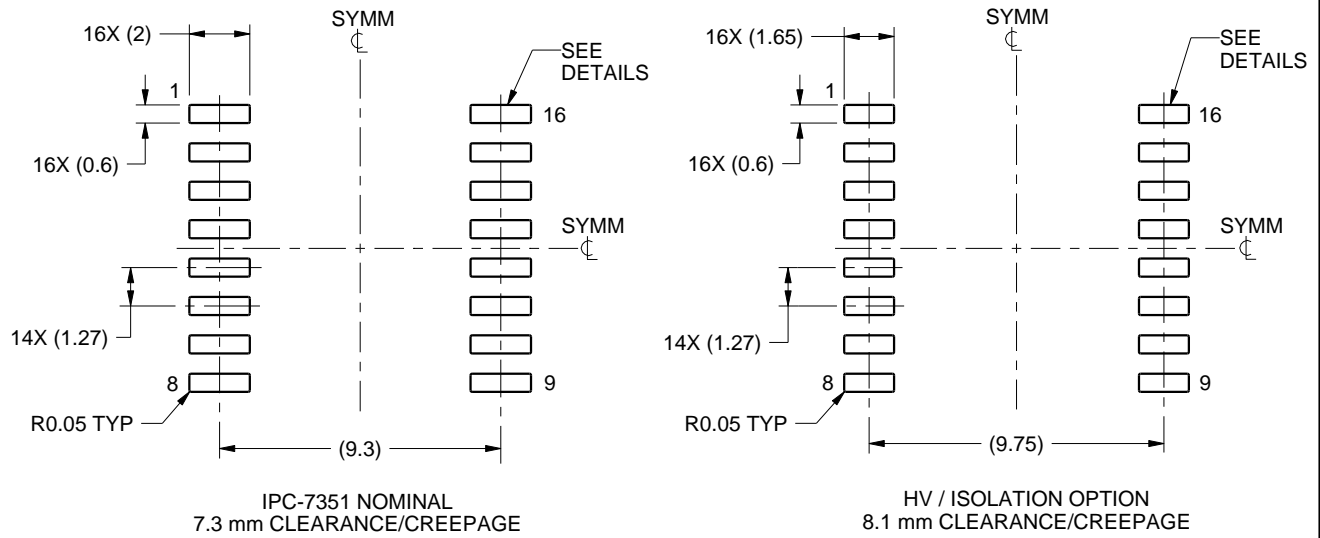

LAND PATTERN EXAMPLE
SCALE:4X

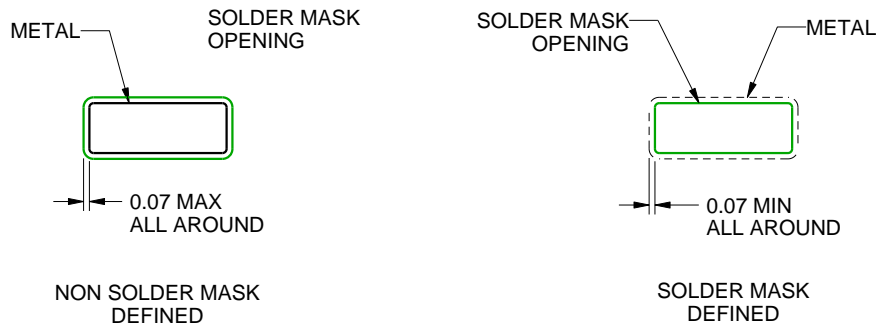

SOLDER MASK DETAILS

4221009/B 07/2016

NOTES: (continued)

- 6. Publication IPC-7351 may have alternate designs.
- 7. Solder mask tolerances between and around signal pads can vary based on board fabrication site.

EXAMPLE STENCIL DESIGN

DW0016B

SOIC - 2.65 mm max height

SOIC

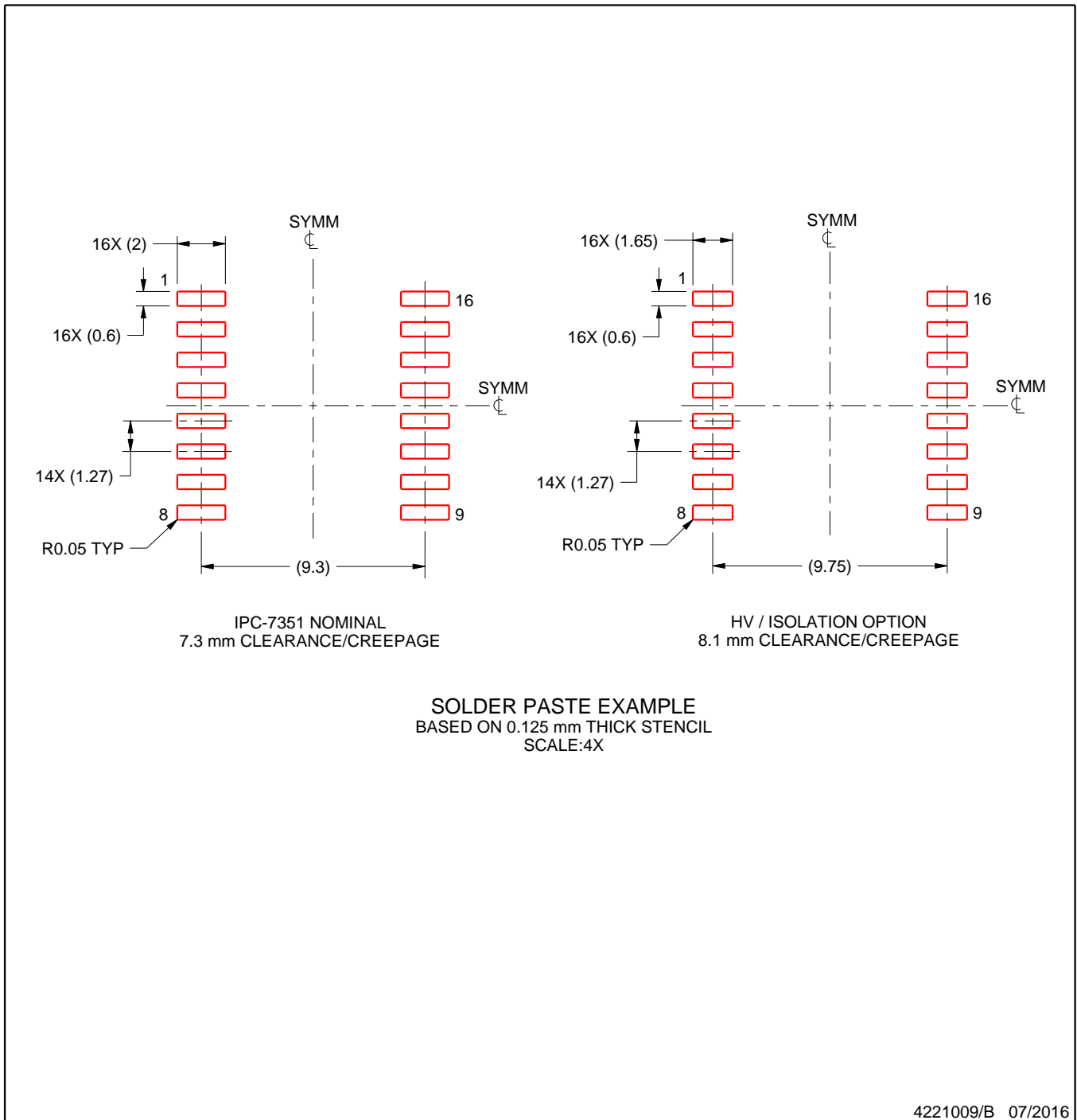

NOTES: (continued)

8. Laser cutting apertures with trapezoidal walls and rounded corners may offer better paste release. IPC-7525 may have alternate design recommendations.
9. Board assembly site may have different recommendations for stencil design.



D0008A

PACKAGE OUTLINE

SOIC - 1.75 mm max height

SMALL OUTLINE INTEGRATED CIRCUIT



4214825/C 02/2019

NOTES:

- Linear dimensions are in inches [millimeters]. Dimensions in parenthesis are for reference only. Controlling dimensions are in inches. Dimensioning and tolerancing per ASME Y14.5M.
- This drawing is subject to change without notice.
- This dimension does not include mold flash, protrusions, or gate burrs. Mold flash, protrusions, or gate burrs shall not exceed .006 [0.15] per side.
- This dimension does not include interlead flash.
- Reference JEDEC registration MS-012, variation AA.

EXAMPLE BOARD LAYOUT

D0008A

SOIC - 1.75 mm max height

SMALL OUTLINE INTEGRATED CIRCUIT



LAND PATTERN EXAMPLE
EXPOSED METAL SHOWN
SCALE:8X



SOLDER MASK DETAILS

4214825/C 02/2019

NOTES: (continued)

6. Publication IPC-7351 may have alternate designs.

7. Solder mask tolerances between and around signal pads can vary based on board fabrication site.

EXAMPLE STENCIL DESIGN

D0008A

SOIC - 1.75 mm max height

SMALL OUTLINE INTEGRATED CIRCUIT



SOLDER PASTE EXAMPLE
BASED ON .005 INCH [0.125 MM] THICK STENCIL
SCALE:8X

4214825/C 02/2019

NOTES: (continued)

8. Laser cutting apertures with trapezoidal walls and rounded corners may offer better paste release. IPC-7525 may have alternate design recommendations.
9. Board assembly site may have different recommendations for stencil design.

IMPORTANT NOTICE AND DISCLAIMER

TI PROVIDES TECHNICAL AND RELIABILITY DATA (INCLUDING DATA SHEETS), DESIGN RESOURCES (INCLUDING REFERENCE DESIGNS), APPLICATION OR OTHER DESIGN ADVICE, WEB TOOLS, SAFETY INFORMATION, AND OTHER RESOURCES "AS IS" AND WITH ALL FAULTS, AND DISCLAIMS ALL WARRANTIES, EXPRESS AND IMPLIED, INCLUDING WITHOUT LIMITATION ANY IMPLIED WARRANTIES OF MERCHANTABILITY, FITNESS FOR A PARTICULAR PURPOSE OR NON-INFRINGEMENT OF THIRD PARTY INTELLECTUAL PROPERTY RIGHTS.

These resources are intended for skilled developers designing with TI products. You are solely responsible for (1) selecting the appropriate TI products for your application, (2) designing, validating and testing your application, and (3) ensuring your application meets applicable standards, and any other safety, security, regulatory or other requirements.

These resources are subject to change without notice. TI grants you permission to use these resources only for development of an application that uses the TI products described in the resource. Other reproduction and display of these resources is prohibited. No license is granted to any other TI intellectual property right or to any third party intellectual property right. TI disclaims responsibility for, and you will fully indemnify TI and its representatives against, any claims, damages, costs, losses, and liabilities arising out of your use of these resources.

TI's products are provided subject to [TI's Terms of Sale](#) or other applicable terms available either on [ti.com](https://www.ti.com) or provided in conjunction with such TI products. TI's provision of these resources does not expand or otherwise alter TI's applicable warranties or warranty disclaimers for TI products.

TI objects to and rejects any additional or different terms you may have proposed.

Mailing Address: Texas Instruments, Post Office Box 655303, Dallas, Texas 75265
Copyright © 2023, Texas Instruments Incorporated

Looking for pricing, stock, or lifecycle information?

Click below to explore more details on WIN SOURCE:

 [View ISO1640BDR](#) on WIN SOURCE

 [Texas Instruments](#) Information

Optimize Your Supply Chain with WIN SOURCE Solutions

-  Global Sourcing Solution
-  Obsolete Management
-  Cost Control Management
-  Shortage Management
-  Alternative Solution
-  Excess Inventory Management