



THE DATASHEET OF MAXNANOPWRBD#



Click [here](#) for production status of specific part numbers.

MAXNANOPWRBD# Evaluation Kit

Evaluates: MAX32660, MAX11615,
MAX40007, MAX9119,
MAX9634, MAX17222

General Description

The MAXNANOPWRBD evaluation kit brings together Maxim's Nanopower technology with the ultra-low power, low pin count, MAX32660 Arm® Cortex®-M4 processor with FPU to create a simple digital multimeter application example running on a single 1.5V alkaline button cell.

The kit includes the following items:

- MAXNANOPWRBD# circuit board
- MAX326325PICO JTAG debugger/programmer

Benefits and Features

- Ultra-Low Power MAX32660 Arm Cortex M4F
- MAX11615 Low Power 8-Channel 12-Bit ADC
- MAX40007 Nanopower Op-Amp
- MAX9119 Nanopower Comparator
- MAX9634 Current Sense Amplifier
- MAX17222 Boost Converter
- PCB mounted Coin Cell Power Source

Ordering Information appears at end of data sheet.

MAXNANOPWRBD# Evaluation Kit Top View

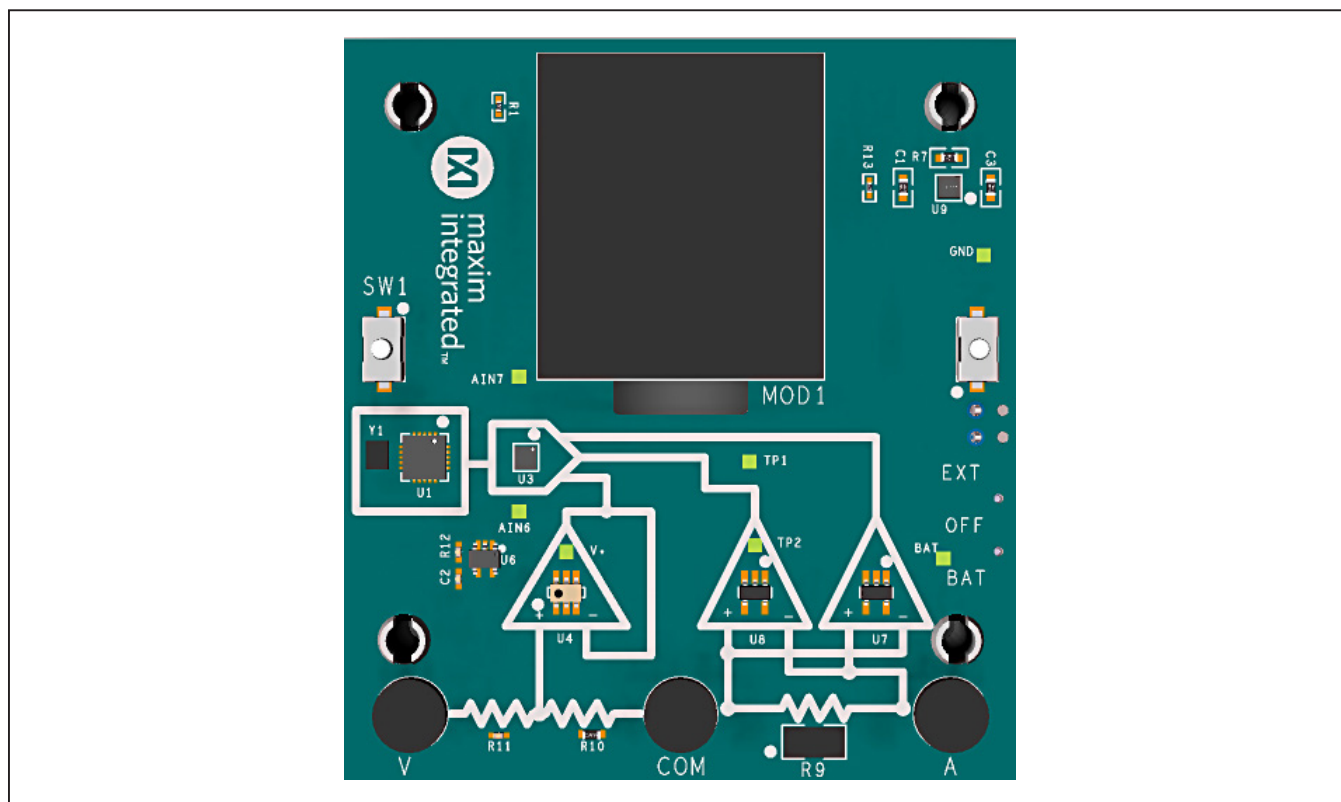

Arm and Cortex are registered trademarks of Arm Limited (or its subsidiaries) in the US and/or elsewhere.

MAXNANOPWRBD# Evaluation Kit

Evaluates: MAX32660, MAX11615, MAX40007, MAX9119, MAX9634, MAX17222

Quick Start

The kit comes preprogrammed with multimeter example firmware. Simply apply power to the board with a 1.5V button cell battery or with an external 1.5V voltage source. SW1 can be used to cycle through the three operational modes: voltage measurement, current measurement, and frequency measurement.

Voltage and frequency measurement is relative to the V and COM terminals. Current measurement uses the A and COM terminals.

Detailed Description

The MAXNANOPWRBD kit implements a simple battery-powered multimeter to demonstrate several low power Maxim analog and digital technologies. Application functionality is provided by firmware that runs on the MAX32660 Arm Cortex-M4 processor with FPU. The analog front-end is implemented with nanopower comparators and operational amplifiers that present measurement signals to the MAX11615 12-bit ADC. The ADC is connected to the MCU through an I²C bus.

The 128x128 pixel LCD is connected to the MCU through a SPI bus and two buttons are provided to complete the multimeter user interface.

The example firmware provided with the kit enables voltage, current, and frequency measurements through the V, A, and COM terminals. Limit voltage measurements to ±10V and current measurements to ±100mA. Kit design does not provide protection and safety circuitry required by commercial multimeter designs. Therefore,

the kit should not be connected to high-voltage sources. Exceeding the specified input ranges will damage the PCB and the components.

The kit can be powered by a single LR44, or similar, 1.5V button cell. The board can optionally be powered externally by a benchtop supply through J2. Maximum input voltage applied to J2 should be limited to 1.5V. SW4 specifies between external power (EXT) and battery power (BAT).

The kit features two connectors for external interfacing. J7 provides a JTAG SWD interface that can be used with the included MAX32635PICO debugger module to program and debug the MAX32660 Arm Cortex M4 processor with FPU. J1 provides access to the I²C bus to interface with the MCU and the ADC. This interface is compatible with Sparkfun's QWIIC system.

Power conversion is provided by the MAX17222, which converts the 1.5V nominal battery voltage to 3.3V for use by the rest of the board.

Firmware

A source code package for the kit can be obtained from Maxim website. Simply use the search tool on Maxim's website and search for "MAXNANOPWRBD". The package is found on the [Design Resources](#) tab.

Information about the source code and how to build, program, and debug it can be found in the source code package.

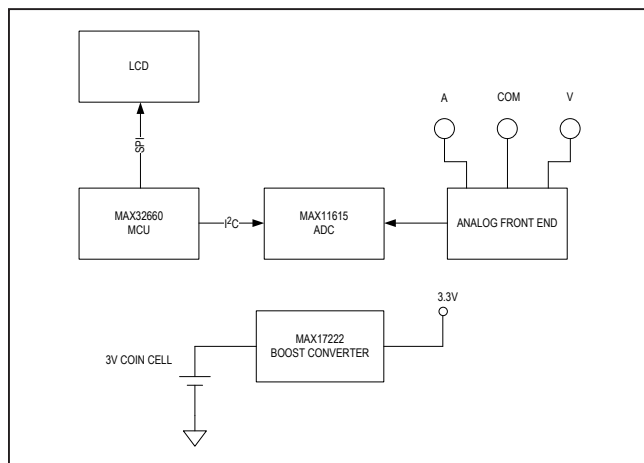

Figure 1. MAXNANOPWRBD# EV Block Diagram

Ordering Information

PART	TYPE
MAXNANOPWRBD#	Evaluation Kit

#Denotes RoHS compliance.

MAXNANOPWRBD# Evaluation Kit

Evaluates: MAX32660, MAX11615,
MAX40007, MAX9119,
MAX9634, MAX17222

MAXNANOPWRBD# EV Bill of Materials

REFDES	QTY	MANUFACTURER	PART NUMBER	DESCRIPTION
BT1	1	KEystone	2996	BATTERY HOLDER; SMT; 11.6MM BUTTON CELL RETAINER; 0.25MM PHOSPHOR BRONZE; TIN NICKEL PLATED
C1, C3	2	TDK	C1608X5R1A106K080AC	CAPACITOR; SMT (0603); CERAMIC CHIP; 10µF; 10V; TOL = 10%; TG = -55°C TO +85°C; TC = X5R
C2, C10, C12	3	MURATA; TDK; TAIYO YUDEN; TDK	GRM155R71E104KE14; C1005X7R1E104K050BB; TMK105B7104KVH; CGJ2B3X7R1E104K050BB	CAPACITOR; SMT (0402); CERAMIC CHIP; 0.1µF; 25V; TOL = 10%; TG = -55°C TO +125°C; TC = X7R
C4-C7, C11, C14	8	KEMET; YAGEO	C0402C105K8PAC; CC0402KRX5R6BB105	CAPACITOR; SMT (0402); CERAMIC CHIP; 1µF; 10V; TOL = 10%; TG = -55°C TO +85°C; TC = X5R
J1	1	JST MANUFACTURING	SM04B-SRSS-TB(LF)(SN)	CONNECTOR; MALE; SMT; DISCONNECTABLE CRIMP STYLE; RIGHT ANGLE; 4PINS
J2	1	PHOENIX CONTACT	1725656	CONNECTOR; FEMALE; THROUGH HOLE; PCB TERMINAL BLOCK; RIGHT ANGLE; 2PINS
J3	1	MOLEX	51441-1093	CONNECTOR; FEMALE; SMT; 0.5MM FPC CONNECTOR; RIGHT ANGLE; 10PINS
J7	1	SAMTEC	FTSH-105-01-L-DV-K	CONNECTOR; MALE; SMT; 0.05 (1.27MM) SMT MICRO HEADER; STRAIGHT; 10PINS
L1	1	WURTH ELECTRONICS INC.	74479276222	INDUCTOR; SMT (0806); MOLDED CHIP; 2.2µH; 30%; 1.40A
MH1-MH4	4	KEystone	9032	ROUND-THRU HOLE SPACER; NO THREAD; M3.5; 5/8IN; NYLON
MOD1	1	SHARP	LS013B7DH03	LCD MODULE; 30.3MM X 26.6MM X 0.851MM; SMT;
R1, R4, R12	3	VISHAY DALE; YAGEO PHICOMP	CRCW040210K0FK; RC0402FR-0710KL	RESISTOR; 0402; 10K; 1%; 100PPM; 0.0625W; THICK FILM
R2, R3	2	VENKEL LTD.; PANASONIC	CR0402-16W-3091FT; ERJ-2RKF309	RESISTOR; 0402; 3.09KΩ; 1%; 100PPM; 0.063W; THICK FILM
R7	1	VISHAY; PANASONIC	CRCW060380K6FK; ERJ-3EKF8062	RESISTOR; 0603; 80.6KΩ; 1%; 100PPM; 0.10W; METAL FILM
R9	1	KOA SPEER	SR732BTDR390F	RES; SMT (1206); 0.390; 1%; ±100PPM/°C; 0.33W
R10	1	PANASONIC	ERJ-3EKF1133	RES; SMT (0603); 113K; 1%; ±100PPM/°C; 0.1W

MAXNANOPWRBD# Evaluation Kit

Evaluates: MAX32660, MAX11615,
MAX40007, MAX9119,
MAX9634, MAX17222

MAXNANOPWRBD# EV Bill of Materials (continued)

REFDES	QTY	MANUFACTURER	PART NUMBER	DESCRIPTION
R11	1	PANASONIC	ERJ-2RKF1004	RESISTOR; 0402; 1MΩ; 1%; 100PPM; 0.10W; THICK FILM
R13	1	STACKPOLE ELECTRONICS INC	HMC0402JT33M0	RESISTOR; 0402; 33MΩ; 5%; 400PPM; 0.063W; THICK FILM
SW1–SW3	3	C&K COMPONENTS	KSR231GLFS	SWITCH; SPST; SMT; 32V; 0.05A; KSR SERIES; SUBMINIATURE TACT SWITCH; RCOIL = 0.1Ω; RINSULATION = 10GΩ; C&K COMPONENTS
SW4	1	ALPS	SSSS211900	SWITCH; SP3T; THROUGH HOLE; 6V; 0.3A
U1	1	MAXIM	MAX32660GTP+	IC; UCON; ULTRA-LOW POWER ARM CORTEX-M4 WITH FPU-BASED MICROCONTROLLER FOR WEARABLE AND IOT SENSORS; TQFN20-EP
U3	1	MAXIM	MAX11615EWE+	IC; ADC; LOW-POWER; 8-CHANNEL; I ² C; 12-BIT ADC; WLP16
U4	1	MAXIM	MAX40007AUT+	IC; OPAMP; NANOPOWER OP AMP; GAIN = 1; SOT23-6
U6	1	MAXIM	MAX9119EXK+	IC; COMP; NANOPOWER; BEYOND-THE-RAILS COMPARATORS WITH/WITHOUT REFERENCE; SC70-5
U7, U8	2	MAXIM	MAX9634TEUK+	IC; AMP; PRECISION CURRENT-SENSE AMPLIFIER; SOT23-5
U9	1	MAXIM	MAX17222ELT+	IC; VCON; 0.4V TO 5.5V INPUT; NANOPOWER SYNCHRONOUS; BOOST CONVERTER WITH TRUE SHUTDOWN; UDFN6
Y1	1	CITIZEN	CM1610H32768DZB	CRYSTAL; SMT 1.6MMX1MM; 6PF; 32.7680KHZ; ±20PPM

MAXNANOPWRBD# EV Schematic

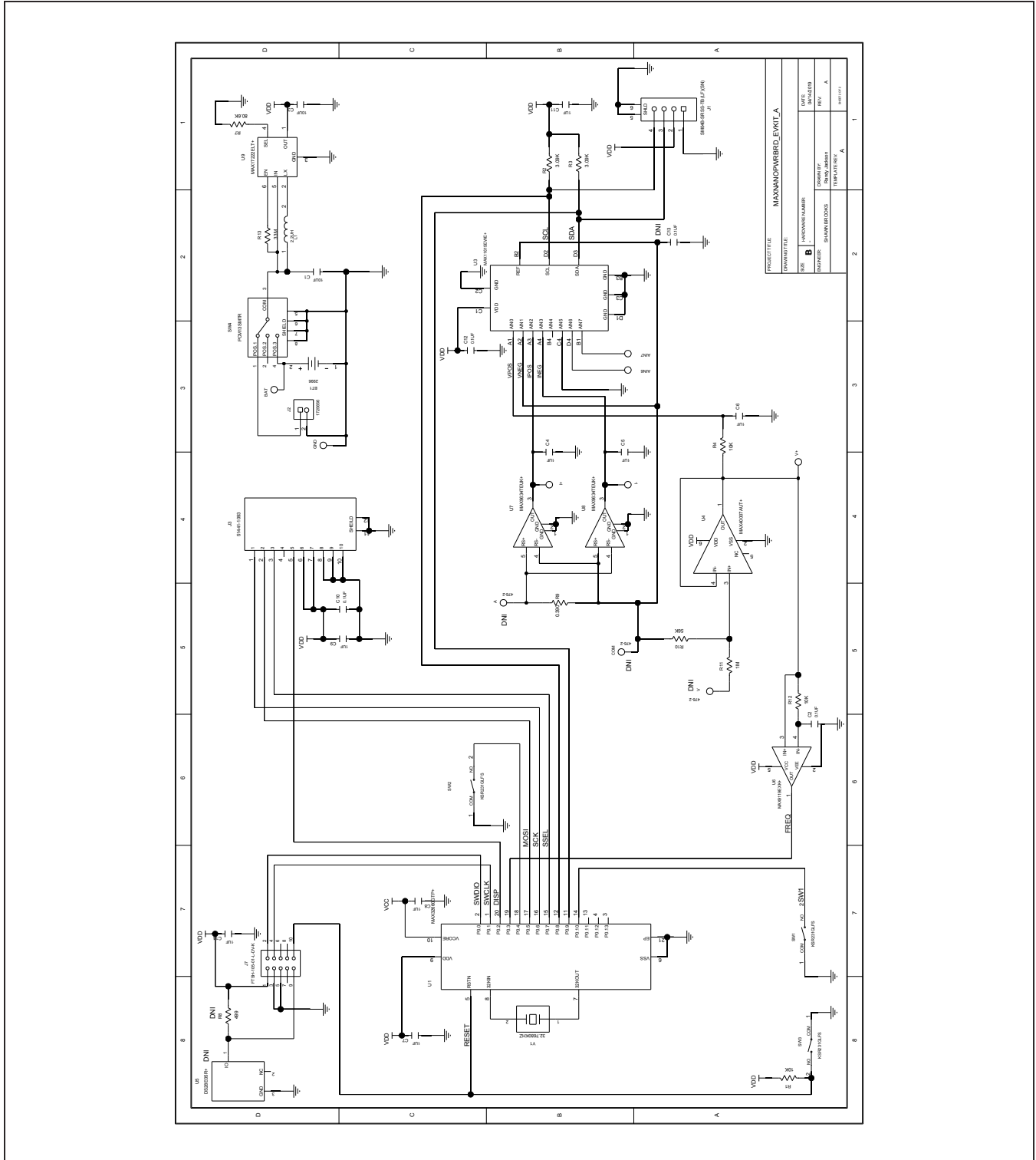

MAXNANOPWRBD# Evaluation Kit

Evaluates: MAX32660, MAX11615,
MAX40007, MAX9119,
MAX9634, MAX17222

MAXNANOPWRBD# EV PCB Layout Diagrams

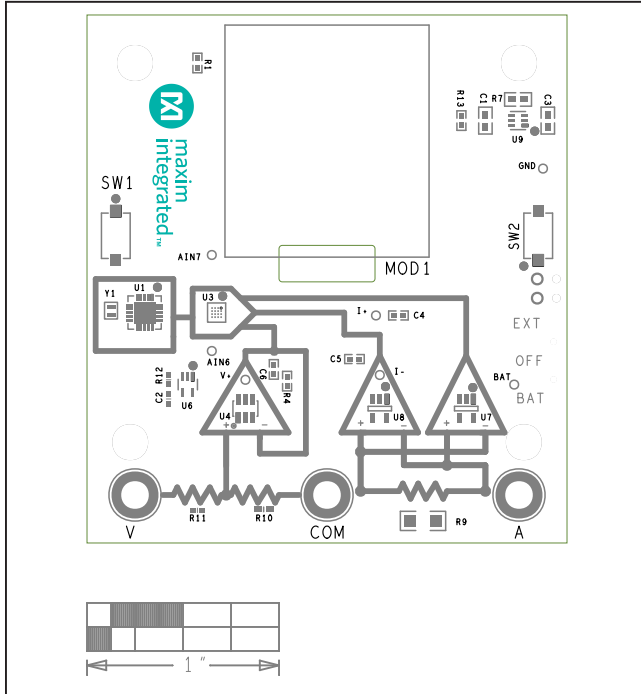

MAXNANOPWRBD# EV PCB Layout—Silk Top

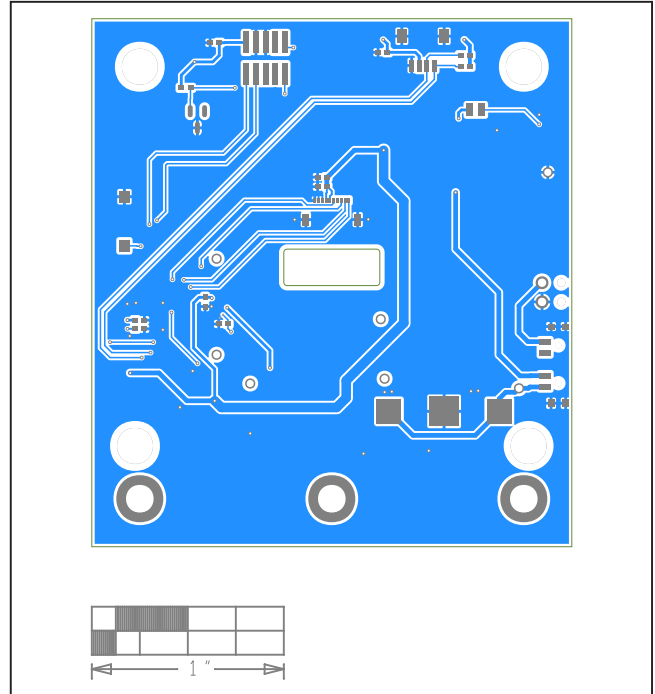

MAXNANOPWRBD# EV PCB Layout—Bottom View

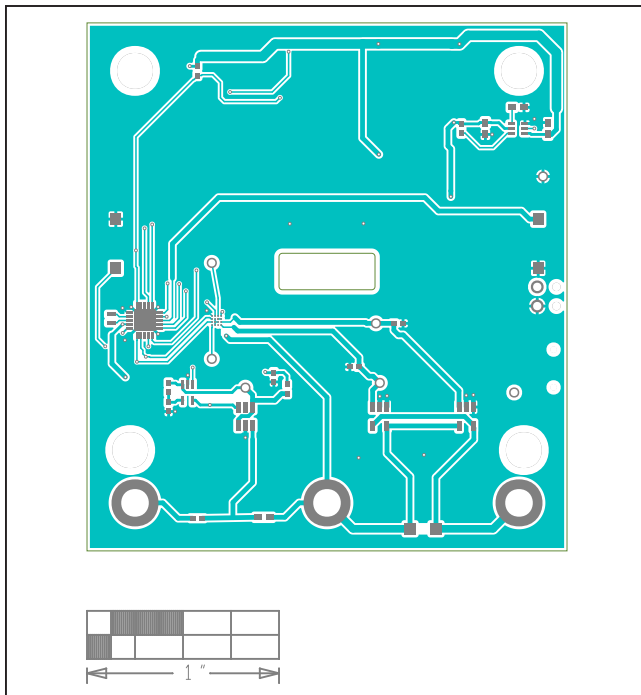

MAXNANOPWRBD# EV PCB Layout—Top View

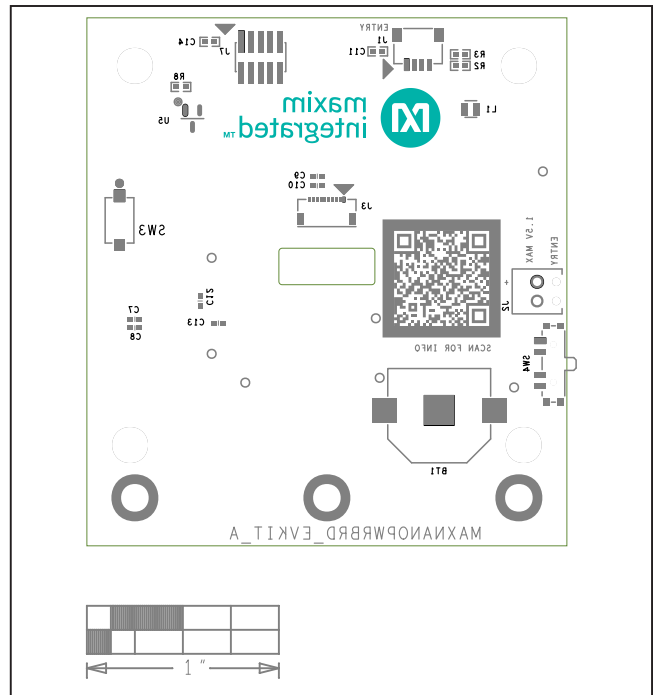

MAXNANOPWRBD# EV PCB Layout—Silk Bottom

Revision History

REVISION NUMBER	REVISION DATE	DESCRIPTION	PAGES CHANGED
0	8/19	Initial release	—
1	10/19	Updated part number, <i>Firmware</i> section, <i>MAXNANOPWRBD# EV Bill of Materials</i> , <i>MAXNANOPWRBD# EV Schematic</i> , and <i>MAXNANOPWRBD# EV PCB Layout Diagrams</i>	1–7
2	10/19	Updated <i>Benefits and Features</i> , <i>Detailed Description</i> , Figure 1, and <i>MAXNANOPWRBD# EV Bill of Materials</i>	1–4
3	12/19	Updated <i>Detailed Description</i> section	2

For pricing, delivery, and ordering information, please visit Maxim Integrated's online storefront at <https://www.maximintegrated.com/en/storefront/storefront.html>.

Maxim Integrated cannot assume responsibility for use of any circuitry other than circuitry entirely embodied in a Maxim Integrated product. No circuit patent licenses are implied. Maxim Integrated reserves the right to change the circuitry and specifications without notice at any time.

Looking for pricing, stock, or lifecycle information?

Click below to explore more details on WIN SOURCE:

- ⊖ [View MAXNANOPWRBD# on WIN SOURCE](#)
- ⊖ [Maxim Integrated Information](#)

Optimize Your Supply Chain with WIN SOURCE Solutions

- ✓ Global Sourcing Solution
- ✓ Obsolete Management
- ✓ Cost Control Management
- ✓ Shortage Management
- ✓ Alternative Solution
- ✓ Excess Inventory Management