



**THE DATASHEET OF  
DS2485EVKIT#**



## Evaluates: DS2485

## DS2485 Evaluation Kit

### General Description

The DS2485 evaluation (EV) kit provides the hardware and software necessary to exercise the features of the DS2485. The EV kit's main hardware consists of a DS9481P-300 USB-to-1-Wire® adapter, DS2485 EV kit peripheral module, and DS9121BQ socket board. Both the DS2485 and DS28E07 devices are included for evaluation. The software runs on Windows® 10, Windows 8, and Windows 7 operating systems and provides a graphical user interface (GUI) to exercise the features of the DS2485.

### Features

- Provides the Ability to Exercise All Functional Commands
- Quickly Create, Save, and Load Custom 1-Wire Scripts
- Customizable Timings Allow for Various 1-Wire Configurations such as Long Lines
- Flexible Timings Ensure Support for Existing and Future Devices
- Alterable I<sup>2</sup>C Address Ensures a Conflict-Free Environment
- Easily Discover Connected 1-Wire Devices with Built-in Search ROM Accelerator
- GPIO Allows External Control or Signaling
- Fully Compliant with USB Specification v2.0

### DS2485 EV Kit Contents

QTY	DESCRIPTION
1	DS2485 EV Kit Peripheral Module
1	DS9481P-300 USB-to-1-Wire Adapter
2	DS9121BQ Socket Board
5	DS2485Q+U
5	DS28E07Q+U
1	USB Type-A to Micro-USB Type-B Cable

**Ordering Information** appears at end of data sheet.

1-Wire is a registered trademark of Maxim Integrated Products, Inc.  
Windows is a registered trademark of Microsoft Corporation.

### Quick Start

#### Required Equipment

- DS2485 EV kit with accompanying software and USB driver
- PC with Windows 10, Windows 8, or Windows 7 operating systems
- System with spare USB 2.0 or higher port

#### Software and Hardware Installation and Setup

- 1) Ensure that there are no other USB devices plugged in before installing the software (keyboard, mouse, USB drives, and printers do not apply).
- 2) Navigate to the DS2485 product page and download the EV kit software zip file.
- 3) Fully unzip the EV kit software.  
**NOTE:** Running the setup from within the zip window without fully extracting it may cause installation issues. Make sure that the files are unzipped to a folder before proceeding.
- 4) Navigate to the USB driver folder.
- 5) Right-click on install.bat and then choose **Run as administrator**.
- 6) Click **Install** when prompted to install the USB device driver.
- 7) Install the jumpers for the DS28E07 IC as described in [Table 1](#), and reference [Figure 1](#) for their locations.
- 8) Insert a DS28E07 IC into the DS9121BQ board and connect it to J2 of the DS2485 EV kit peripheral module, as shown in [Figure 2](#).  
**IMPORTANT:** The pin 1 indicator is on the PCB's silkscreen and is located on the lower left-hand corner. Do not use the dimple inside the socket as the pin 1 indicator.
- 9) Connect J1 of the DS2485 EV kit peripheral module to the DS9481P-300 for the system to work properly.
- 10) Connect the USB cable to the DS9481P-300 adapter and plug it into a USB port.

Table 1. DS9121BQ Socket Board Jumper Settings

REFERENCE DESIGNATOR	JUMPER SETTING	NOTES
JB1, JB2, JB3, and JB4	Not installed	DS28E07Q+ inserted in the socket
JB5	Installed	

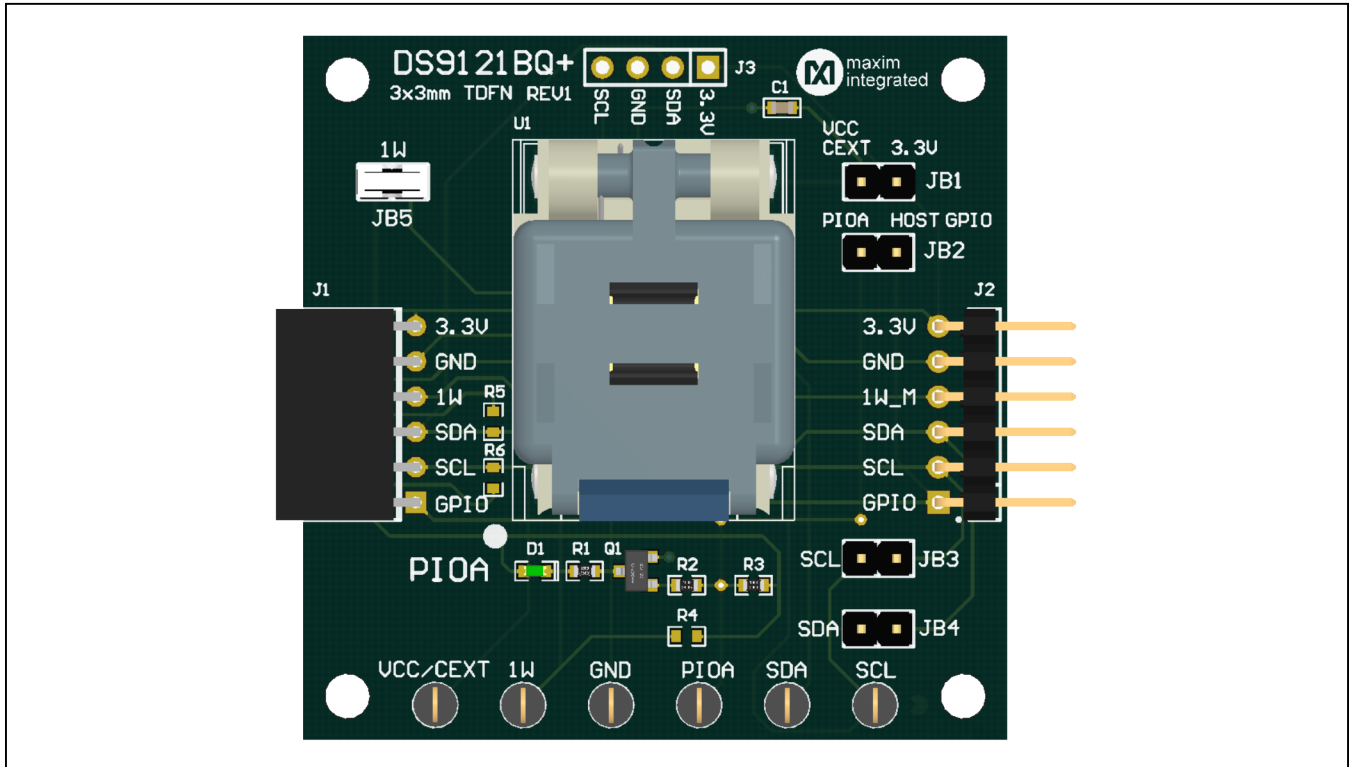

Figure 1. DS9121BQ Socket Board

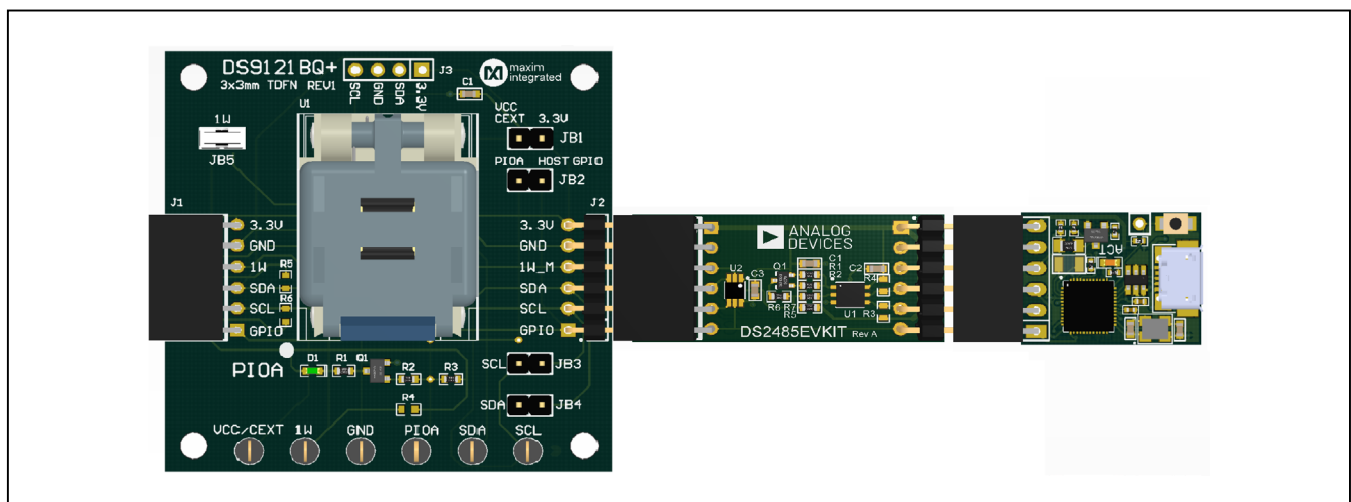

Figure 2. Board Connectivity

- 11) Windows detects the hardware and automatically installs the USB driver.
- 12) Double-click on the Setup.exe file to install the DS2485 EV kit software.
- 13) The EV kit software will automatically start after installation completes (Figure 3).
- 14) Do not run setup.exe to launch the program because it will install a second copy. Instead, use the DS2485 EV kit shortcut from the Windows' Start menu for subsequent launches.

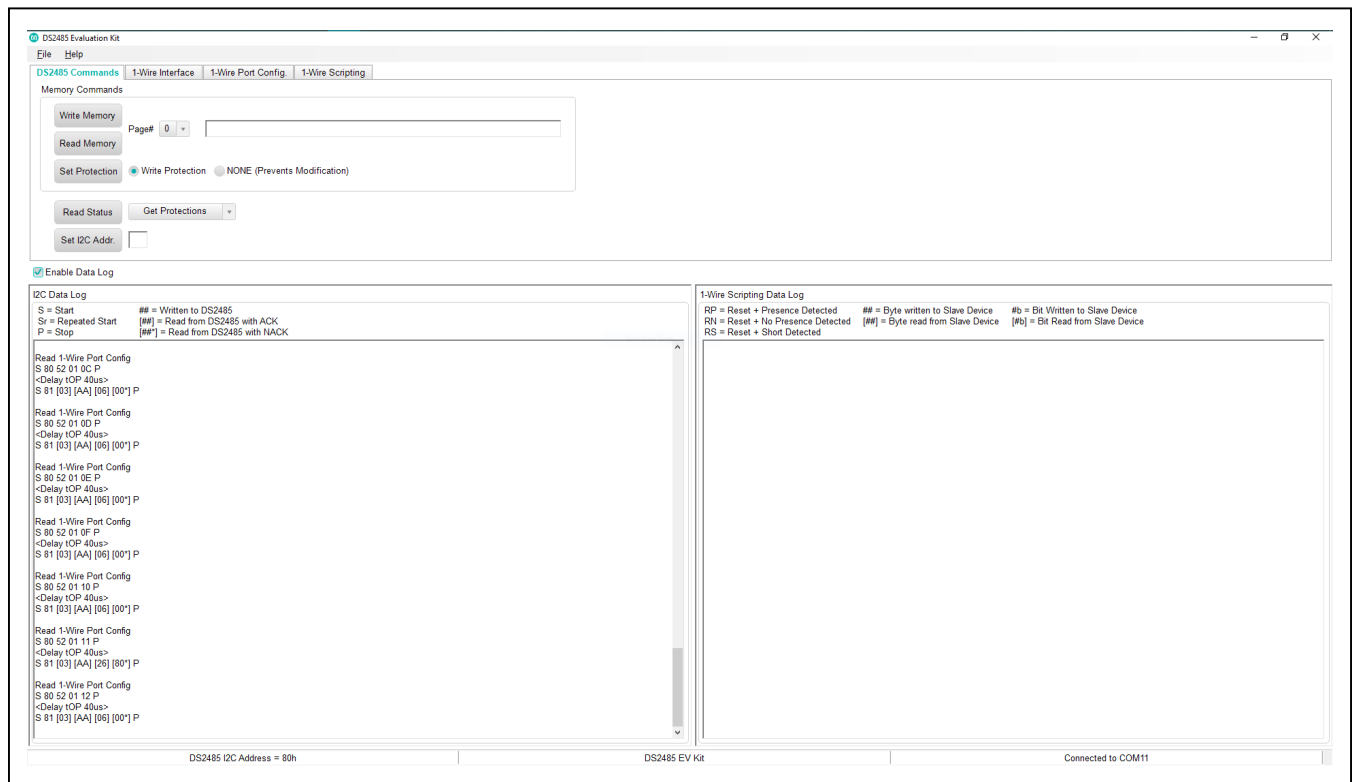

Figure 3. DS2485 Evaluation Kit Software

**DS2485 EV Kit Supported Functions**

The DS2485 EV kit program supports every command outlined in the device’s data sheet with functionality

divided across the various tabs in the application. [Table 2](#) provides a brief description for the operations found on each tab.

**Table 2. Menu Tabs**

TAB NAME	DESCRIPTION
DS2485 Commands	Provides read and write access to the DS2485’s memory pages, protection settings, and Read Status command, and allows customization of its I <sup>2</sup> C address.
1-Wire Interface	Showcases the use of the integrated Search ROM accelerator, Write/Read Block functions, and Full Command Sequence used for authenticator devices.
1-Wire Port Config	Allows for customized 1-Wire timings for standard and overdrive speeds and provides access to the various registers for configuring 1-Wire pullup, thresholds, slew rate, and other registers. This tab also contains the CRC-16 computation engine, as well as the ability to perform a Master Reset.
1-Wire Scripting	Supports the sequencing of all fundamental 1-Wire commands to develop communication sequences for any device. Script commands can easily be constructed, executed, and saved for later use.

**Ordering Information**

PART	TYPE
DS2485EVKIT#	EV Kit

#Denotes RoHS compliant

DS2485 EV Kit Peripheral Module Bill of Materials

DESIGNATOR	QTY	DESCRIPTION	MANUFACTURER	PART NUMBER
C1	1	CAP CER 1UF 35V X5R 0603	Taiyo Yuden	GMK107BJ105KA
C2, C3	2	CAP+,0.1uF,10%,50V,X7R,0603	Murata Electronics	GRM188R71H104KA93
J1	1	CONN HEADER R/A 6POS 2.54MM	Wurth Electronics	61300611021
J2	1	CONN+,FEMALE,6POS,.100",R/A,GOLD	Sullins Connector	PPPC061LGBN-RC
Q1	1	MOSFET P-CH 20V 630MA SOT323-3	Infineon	BSS209PWH6327XTSA1
R1	1	RES#,100K OHM,1%,1/10W,0603,AUTO	Vishay Dale	CRCW0603100KFK
R2	1	RES#,1K OHM,1%,1/10W,0603,AUTO	Vishay Dale	CRCW06031K00FK
R6	1	RES#,4.99 OHM,1%,0603	Vishay Dale	CRCW06034R99FK
R7	1	RES#,1 OHM,1%,0603	Vishay Dale	CRCW06031R00FK
U1	1	ADVANCED 1-Wire CONTROLLER	Analog Devices	DS2485Q+U
U2	1	ESD PROTECTORS IN UDFN	Analog Devices	MAX13204EALT+

DS2485 EV Kit Peripheral Module Schematic Diagram

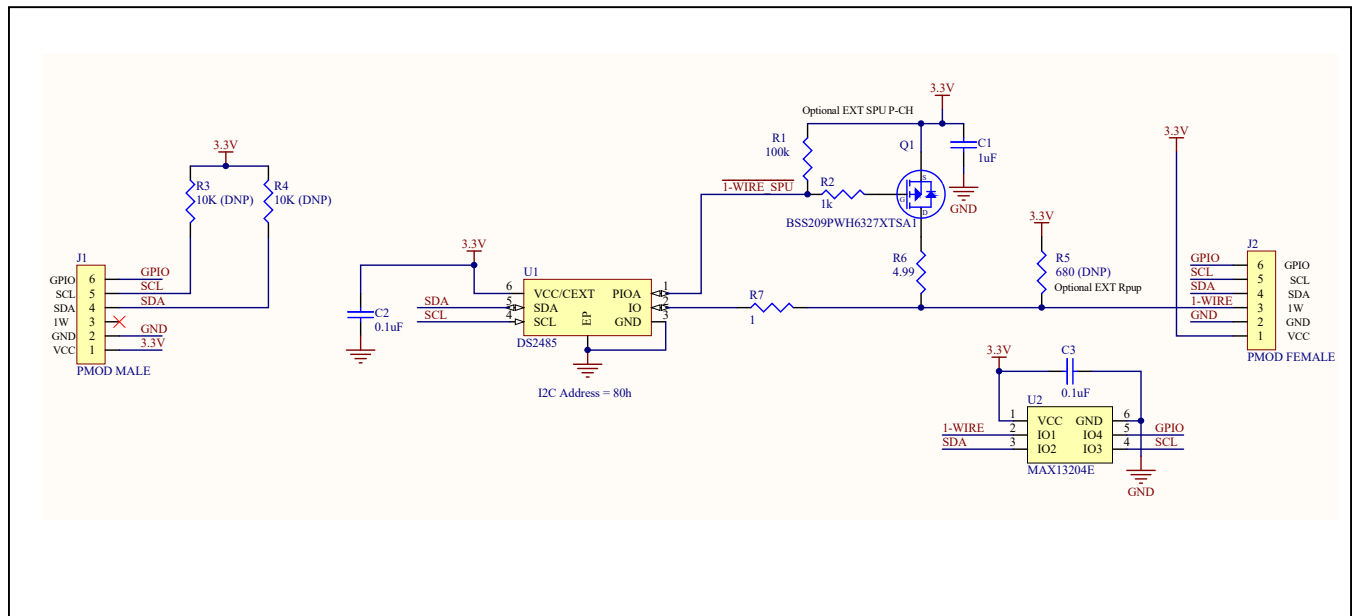

DS2485BQ Socket Board Bill of Materials

DESIGNATOR	QTY	DESCRIPTION	MANUFACTURER	PART NUMBER
J1	1	CONN FEMALE 6POS .100" R/A GOLD	Sullins Connector Solutions	PPPC061LGBN-RC
J2	1	CONN HEADER 6 POS RA 2.54	Würth Electronics Inc.	61300611021
TP1-TP6	6	TEST POINT PC MULTI PURPOSE BLK	Keystone Electronics	5011
U1	1	SOCKET+, IC TDFN, 3mm, 3x2, CLAMSHELL	PLASTRONICS	06QN10T23030
C1	1	CAP CER 0.47µF 16V X7R 0603	KEMET	C0603C474K4RACTU
D1	1	LED GREEN CLEAR 0603 SMD	Dialight	5988081107F
JB1-JB5	5	CONN HEADER 2 POS 2.54	Würth Electronics Inc.	61300211121
Q1	1	MOSFET N-CH 50V 200MA SOT23	ON Semiconductor	BSS138LT1G
R1, R3	2	RES SMD, 10kΩ, 0.1%, 1/10W 0603	Bourns Inc.	CRT0603-BY-10R0ELF
R2	1	RES SMD, 3.3kΩ, 1%, 0603	Yageo	RC0402JR-071K5L
R4, R5, R6	3	DNP (do not populate)	—	—

DS2485BQ Socket Board Schematic Diagram

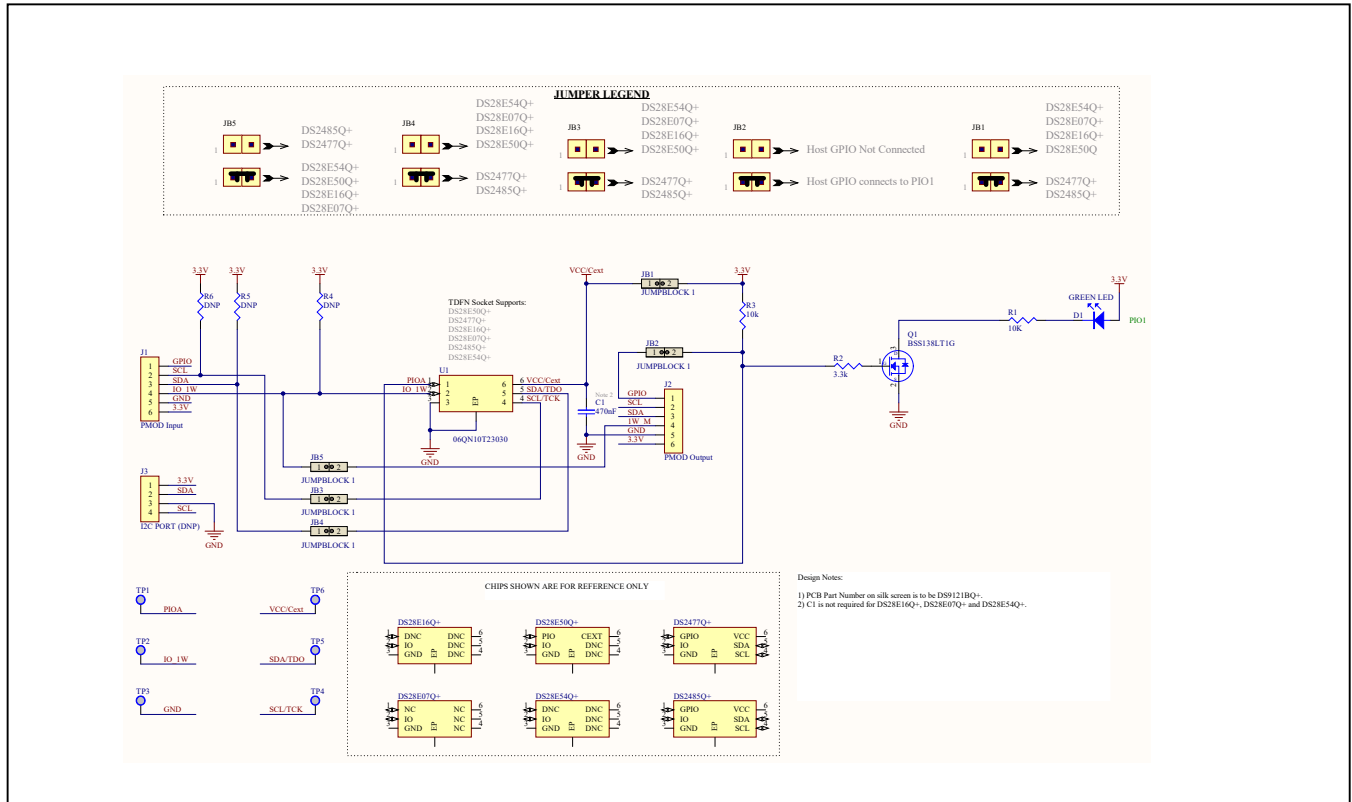

DS9121 EV Kit Peripheral Module PCB Layout Diagrams

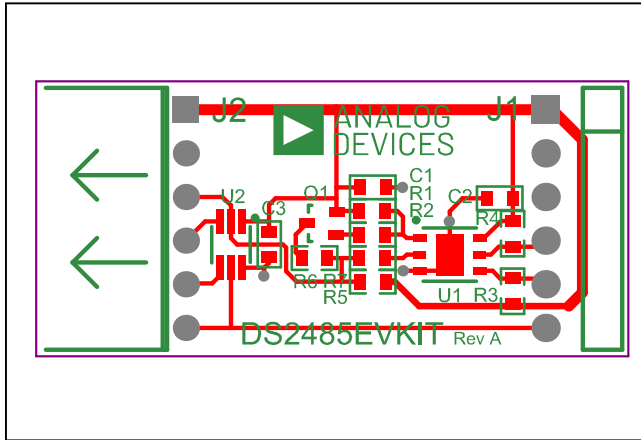

DS9121BQ Socket Board Layout Diagram—Top

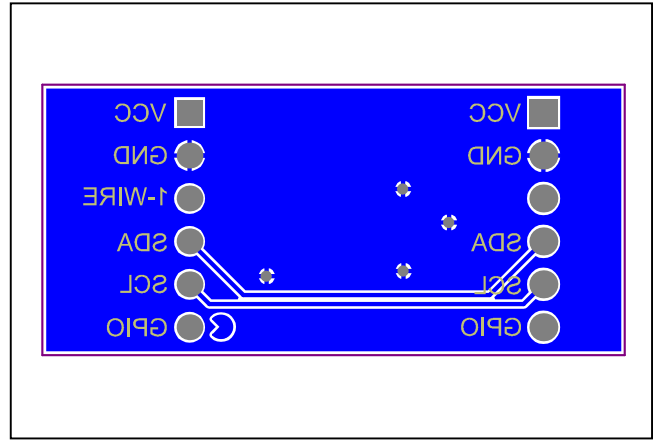

DS9121BQ Socket Board Layout Diagram—Bottom

DS9121BQ Socket Board PCB Layout Diagrams

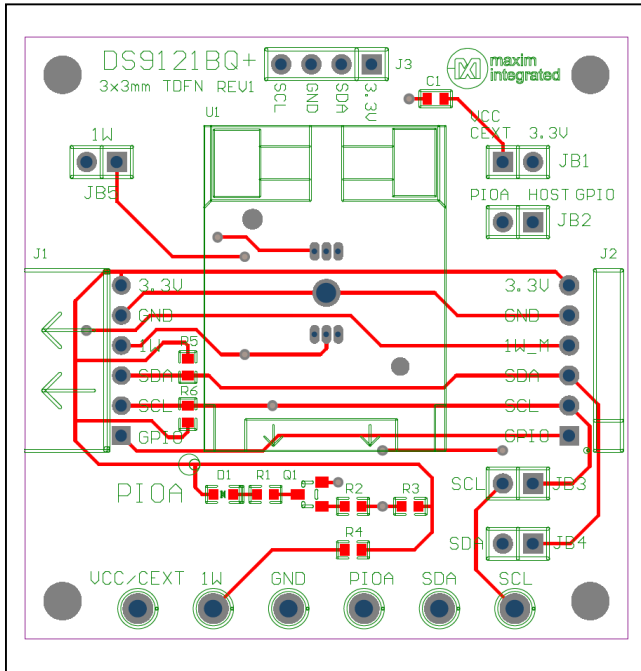

DS9121 EV Kit Peripheral Module Layout Diagram—Top

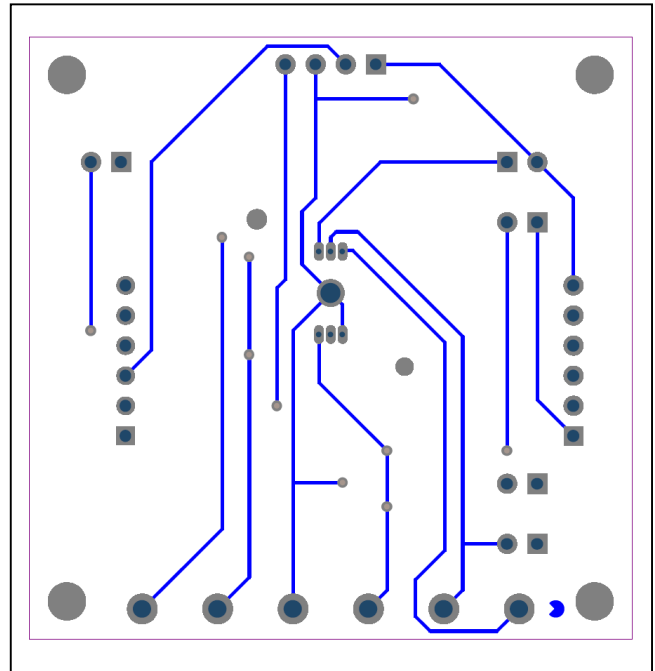

DS9121 EV Kit Peripheral Module Layout Diagram—Bottom

**Revision History**

<b>REVISION NUMBER</b>	<b>REVISION DATE</b>	<b>DESCRIPTION</b>	<b>PAGES CHANGED</b>
0	5/21	Initial release	—
1	12/23	Removed 1 of 2 DS9121BQ boards; added DS2485 EV kit board	1–3, 5–7



## Looking for pricing, stock, or lifecycle information?

Click below to explore more details on WIN SOURCE:

- ⊖ [View DS2485EVKIT#](#) on WIN SOURCE
- ⊖ [Maxim Integrated](#) Information

## Optimize Your Supply Chain with WIN SOURCE Solutions

- ✓ Global Sourcing Solution
- ✓ Obsolete Management
- ✓ Cost Control Management
- ✓ Shortage Management
- ✓ Alternative Solution
- ✓ Excess Inventory Management