





**Please note that Cypress is an Infineon Technologies Company.**

The document following this cover page is marked as “Cypress” document as this is the company that originally developed the product. Please note that Infineon will continue to offer the product to new and existing customers as part of the Infineon product portfolio.

**Continuity of document content**

The fact that Infineon offers the following product as part of the Infineon product portfolio does not lead to any changes to this document. Future revisions will occur when appropriate, and any changes will be set out on the document history page.

**Continuity of ordering part numbers**

Infineon continues to support existing part numbers. Please continue to use the ordering part numbers listed in the datasheet for ordering.

# System Hardware Manager (SHM)

## General Description

SHM 35-Series is a scalable and reconfigurable platform architecture for a family of full programmable embedded system controllers with an ARM® Cortex™-M0 CPU. It combines programmable and reconfigurable analog and digital blocks with flexible automatic routing. The SHM35920-M product family, based on this platform architecture, is a combination of a microcontroller with digital programmable logic, programmable analog, programmable interconnect, high-performance analog-to-digital conversion, opamps with comparator mode, and standard communication and timing peripherals. The programmable analog and digital subsystems allow flexibility and in-field tuning of the design.

## Features

### 32-bit MCU Subsystem

- 24-MHz ARM Cortex-M0 CPU with single-cycle multiply
- Up to 128 kB of flash with Read Accelerator
- Up to 16 kB of SRAM
- DMA engine with 8 channels

### Programmable Analog

- Four opamps that operate in Deep Sleep mode at very low current levels
- All opamps have reconfigurable high current pin-drive, high-bandwidth internal drive, ADC input buffering, and Comparator modes with flexible connectivity allowing input connections to any pin
- Two current DACs (IDACs) for general-purpose applications on any pin
- Two low-power comparators that operate in Deep Sleep mode
- 12-bit SAR ADC with 806-Ksps conversion rate

### Low Power 1.71 to 5.5 V Operation

- 20-nA Stop Mode with GPIO pin wakeup
- Hibernate and Deep Sleep modes allow wakeup-time versus power trade-offs

### Segment LCD Drive

- LCD drive supported on all pins (common or segment)
- Operates in Deep Sleep mode with 4 bits per pin memory

### Serial Communication

- Four independent run-time reconfigurable serial communication blocks (SCBs) with reconfigurable I<sup>2</sup>C, SPI, or UART functionality

### Timing and Pulse-Width Modulation

- Eight 16-bit timer/counter pulse-width modulator (TCPWM) blocks
- Center-aligned, Edge, and Pseudo-random modes
- Comparator-based triggering of Kill signals for motor drive and other high-reliability digital logic applications

### Package Options

- 68-pin QFN package
- Up to 55 programmable GPIOs
- GPIO pins can be LCD, analog, or digital
- Drive modes, strengths, and slew rates are programmable
- Pin compatible with select PSoC 4 devices
- Packages assembled with Ultra Low Alpha (ULA) mold compounds and materials to reduce rate of alpha particle related failures

### PSoC Creator Design Environment

- Integrated Development Environment (IDE) provides schematic design entry and build (with analog and digital automatic routing)
- Applications Programming Interface (API component) for all fixed-function and programmable peripherals

### Industry-Standard Tool Compatibility

- After schematic entry, development can be done with ARM-based industry-standard development tools

### Contents

<b>Functional Definition</b> .....	<b>4</b>	Device Level Specifications .....	13
CPU and Memory Subsystem .....	4	Analog Peripherals .....	18
System Resources .....	4	Digital Peripherals .....	23
Analog Blocks .....	5	Memory .....	25
Fixed Function Digital .....	6	System Resources .....	26
GPIO .....	7	<b>Ordering Information</b> .....	<b>29</b>
Special Function Peripherals .....	7	<b>Packaging</b> .....	<b>30</b>
<b>Pinouts</b> .....	<b>8</b>	<b>Acronyms</b> .....	<b>31</b>
<b>Power</b> .....	<b>11</b>	<b>Document Conventions</b> .....	<b>33</b>
Unregulated External Supply .....	11	Units of Measure .....	33
Regulated External Supply .....	11	<b>Revision History</b> .....	<b>34</b>
<b>Development Support</b> .....	<b>12</b>	<b>Sales, Solutions, and Legal Information</b> .....	<b>35</b>
Documentation .....	12	Worldwide Sales and Design Support .....	35
Online .....	12	Products .....	35
Tools .....	12	PSoC® Solutions .....	35
<b>Electrical Specifications</b> .....	<b>13</b>	Cypress Developer Community .....	35
Absolute Maximum Ratings .....	13	Technical Support .....	35

## SHM 35920-M Block Diagram

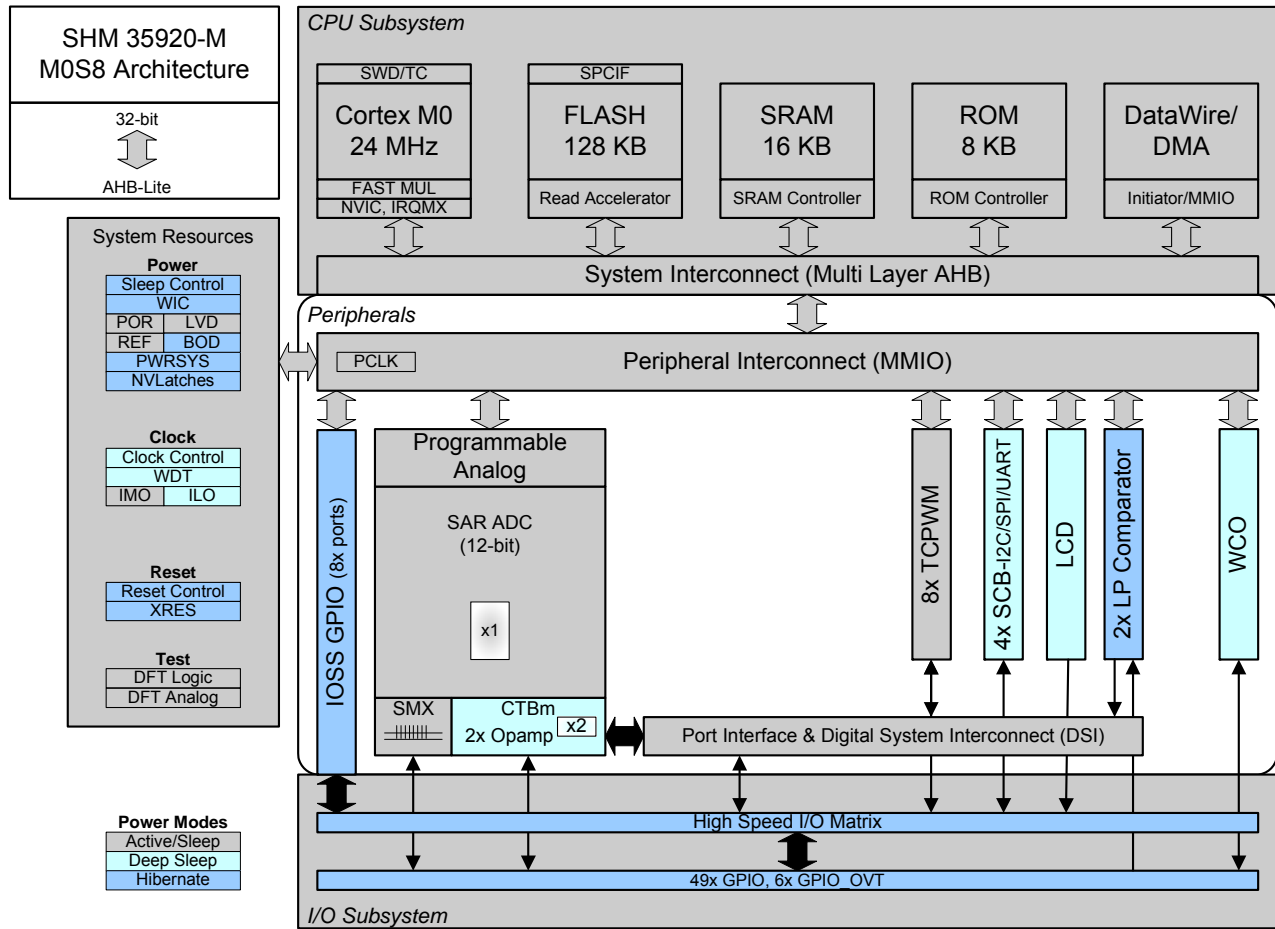

The SHM35920-M devices include extensive support for programming, testing, debugging, and tracing both hardware and firmware.

The ARM Serial Wire Debug (SWD) interface supports all programming and debug features of the device.

Complete debug-on-chip functionality enables full-device debugging in the final system using the standard production device. It does not require special interfaces, debugging pods, simulators, or emulators. Only the standard programming connections are required to fully support debug.

The PSoC Creator Integrated Development Environment (IDE) provides fully integrated programming and debug support for SHM35920-M devices. The SWD interface is fully compatible with industry-standard third-party tools. The SHM35920-M family provides a level of security not possible with multi-chip application solutions or with microcontrollers. This is due to its ability to disable debug features, robust flash protection, and because

it allows customer-proprietary functionality to be implemented in on-chip programmable blocks.

The debug circuits are enabled by default and can only be disabled in firmware. If not enabled, the only way to re-enable them is to erase the entire device, clear flash protection, and reprogram the device with new firmware that enables debugging.

Additionally, all device interfaces can be permanently disabled (device security) for applications concerned about phishing attacks due to a maliciously reprogrammed device or attempts to defeat security by starting and interrupting flash programming sequences. Because all programming, debug, and test interfaces are disabled when maximum device security is enabled, SHM35920-M with device security enabled may not be returned for failure analysis. This is a trade-off the SHM35920-M allows the customer to make.

## Functional Definition

### CPU and Memory Subsystem

#### CPU

The Cortex-M0 CPU in SHM35920-M is part of the 32-bit MCU subsystem, which is optimized for low-power operation with extensive clock gating. Most instructions are 16 bits in length and execute a subset of the Thumb-2 instruction set. The Cypress implementation includes a hardware multiplier that provides a 32-bit result in one cycle. It includes a nested vectored interrupt controller (NVIC) block with 32 interrupt inputs and also includes a Wakeup Interrupt Controller (WIC), which can wake the processor up from the Deep Sleep mode allowing power to be switched off to the main processor when the chip is in the Deep Sleep mode. The Cortex-M0 CPU provides a Non-Maskable Interrupt (NMI) input, which is made available to the user when it is not in use for system functions requested by the user.

The CPU also includes a debug interface, the serial wire debug (SWD) interface, which is a 2-wire form of JTAG; the debug configuration used for SHM35920-M has four break-point (address) comparators and two watchpoint (data) comparators.

#### Flash

The SHM35920-M has a flash module with a flash accelerator, tightly coupled to the CPU to improve average access times from the flash block. The flash accelerator delivers 85% of single-cycle SRAM access performance on average. Part of the flash module can be used to emulate EEPROM operation if required.

#### SRAM

SRAM memory is retained during Hibernate.

#### SROM

A supervisory ROM that contains boot and configuration routines is provided.

#### DMA

ADMA engine, with eight channels, is provided that can do 32-bit transfers and has chainable ping-pong descriptors.

### System Resources

#### Power System

The power system is described in detail in the section [Power on page 11](#). It provides assurance that voltage levels are as required for each respective mode and either delay mode entry (on power-on reset (POR), for example) until voltage levels are as required for proper function or generate resets (brown-out detect (BOD)) or interrupts (low voltage detect (LVD)). SHM35920-M operates with a single external supply over the range of 1.71 to 5.5 V and has five different power modes, transitions between which are managed by the power system. SHM35920-M provides Sleep, Deep Sleep, Hibernate, and Stop low-power modes.

#### Clock System

The SHM35920-M clock system is responsible for providing clocks to all subsystems that require clocks and for switching between different clock sources without glitching. In addition, the clock system ensures that no meta-stable conditions occur.

The SHM35920-M clock system consists of a Watch Crystal Oscillator (WCO) running at 32 kHz, the IMO (3 to 48 MHz) and the ILO (32-kHz nominal) internal oscillators, and provision for an external clock.

**Figure 1. SHM35920-M MCU Clocking Architecture**

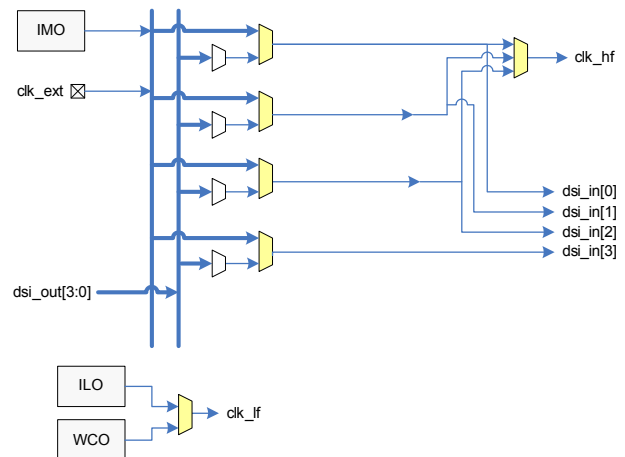

The clk\_hf signal can be divided down to generate synchronous clocks for the analog and digital peripherals. There are a total of 16 clock dividers for the SHM35920-M devices, each with 16-bit divide capability. The analog clock leads the digital clocks to allow analog events to occur before digital clock-related noise is generated. The 16-bit capability allows a lot of flexibility in generating fine-grained frequency values and is fully supported in PSoC Creator.

#### IMO Clock Source

The IMO is the primary source of internal clocking in SHM35920-M. It is trimmed during testing to achieve the specified accuracy. Trim values are stored in nonvolatile memory. Trimming can also be done on the fly to allow in-field calibration. The IMO default frequency is 24 MHz and it can be adjusted between 3 to 48 MHz in steps of 1 MHz. IMO tolerance with Cypress-provided calibration settings is  $\pm 2\%$ .

#### ILO Clock Source

The ILO is a very low power oscillator, nominally 32 kHz, which is primarily used to generate clocks for peripheral operation in Deep Sleep mode. ILO-driven counters can be calibrated to the IMO to improve accuracy. Cypress provides a software component, which does the calibration.

#### Crystal Oscillator

The SHM35920-M clock subsystem also includes a low-frequency crystal oscillator (32-kHz WCO) that is available during the Deep Sleep mode and can be used for Real-Time Clock (RTC) and Watchdog Timer applications.

### Watchdog Timer

A watchdog timer is implemented in the clock block running from the low-frequency clock; this allows watchdog operation during Deep Sleep and generates a watchdog reset or an interrupt if not serviced before the timeout occurs. The watchdog reset is recorded in the Reset Cause register.

### Reset

SHM35920-M can be reset from a variety of sources including a software reset. Reset events are asynchronous and guarantee reversion to a known state. The reset cause is recorded in a register, which is sticky through reset and allows software to determine the cause of the reset. An XRES pin is reserved for external reset to avoid complications with configuration and multiple pin functions during power-on or reconfiguration.

### Voltage Reference

The SHM35920-M reference system generates all internally required references. A 1% voltage reference spec is provided for the 12-bit ADC. To allow better signal-to-noise ratios (SNR) and better absolute accuracy, it is possible to add an external bypass capacitor to the internal reference using a GPIO pin or to use an external reference for the SAR.

## Analog Blocks

### 12-bit SAR ADC

The 12-bit SAR ADC can operate at a maximum sample rate of 806 ksp/s.

The block functionality is augmented for the user by adding a reference buffer to it (trimmable to  $\pm 1\%$ ) and by providing the choice of three internal voltage references:  $V_{DD}$ ,  $V_{DD}/2$ , and  $V_{REF}$  (nominally 1.024 V) as well as an external reference

through a GPIO pin. The Sample-and-Hold (S/H) aperture is programmable allowing the gain bandwidth requirements of the amplifier driving the SAR inputs, which determine its settling time, to be relaxed if required. The system performance will be 65 dB for true 12-bit precision if appropriate references are used and system noise levels permit. To improve performance in noisy conditions, it is possible to provide an external bypass (through a fixed pin location) for the internal reference amplifier.

The SAR is connected to a fixed set of pins through an 8-input sequencer (expandable to 16 inputs). The sequencer cycles through selected channels autonomously (sequencer scan) and does so with zero switching overhead (that is, the aggregate sampling bandwidth is equal to 1 Msps, whether it is for a single channel or distributed over several channels). The sequencer switching is effected through a state machine or through firmware-driven switching. A feature provided by the sequencer is buffering of each channel to reduce CPU interrupt service requirements. To accommodate signals with varying source impedance and frequency, it is possible to have different sample times programmable for each channel. In addition, the signal range specification through a pair of range registers (low and high range values) is implemented with a corresponding out-of-range interrupt if the digitized value exceeds the programmed range; this allows fast detection of out-of-range values without the necessity of having to wait for a sequencer scan to be completed and the CPU to read the values and check for out-of-range values in software.

The SAR is able to digitize the output of the on-board temperature sensor for calibration and other temperature-dependent functions. The SAR is not available in Deep Sleep and Hibernate modes as it requires a high-speed clock. The SAR operating range is 1.71 to 5.5 V.

Figure 2. SAR ADC System Diagram

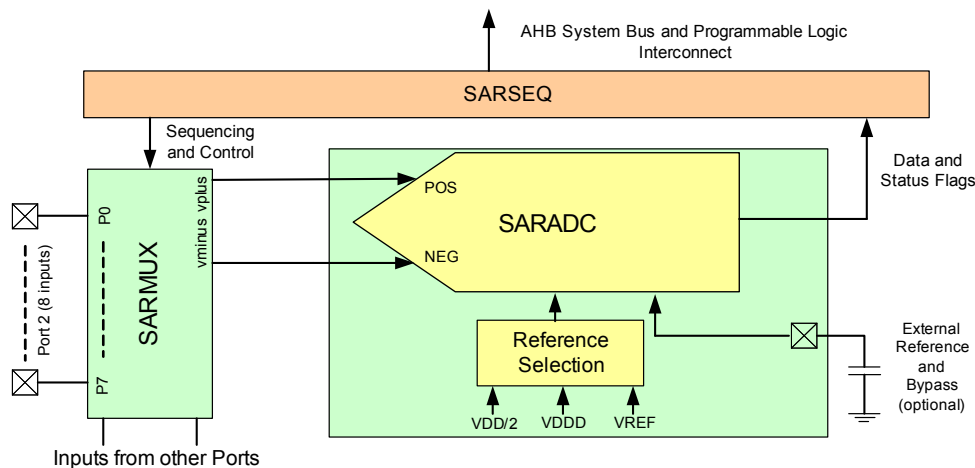

## Analog Multiplex Bus

The SHM35920-M consists of two concentric analog buses (Analog Mux Bus A and Analog Mux Bus B) that circumnavigate the periphery of the chip. These buses can transport analog signals from any pin to various analog blocks (including the opamps) allowing, for example, the ADC to monitor any pin on the chip. These buses are independent and can also be split into three independent sections. This allows one section to be used for general analog signal processing, and another for general-purpose digital peripherals and GPIO.

## Four Opamps

The SHM35920-M devices have four opamps with comparator modes, which allow most common analog functions to be performed on-chip eliminating external components; PGAs, voltage buffers, filters, trans-impedance amplifiers, and other functions can be realized with external passives saving power, cost, and space. The on-chip opamps are designed with enough bandwidth to drive the Sample-and-Hold circuit of the ADC without requiring external buffering. The opamps can operate in the Deep Sleep mode at very low power levels. The following diagram shows one of two identical opamp pairs of the opamp subsystem.

**Figure 3. Identical Opamp Pairs in Opamp Subsystem**

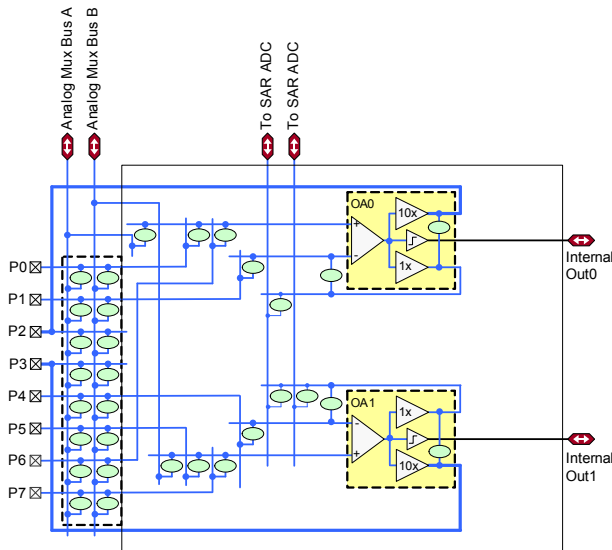

The ovals in Figure 3 represent analog switches, which may be controlled via user firmware, the SAR sequencer, or user-defined programmable logic. The opamps (OA0 and OA1) are configurable via these switches to perform all standard opamp functions with appropriate feedback components.

The opamps (OA0 and OA1) are programmable and reconfigurable to provide standard opamp functionality via switchable feedback components, unity gain functionality for driving pins directly, or for internal use (such as buffering SAR ADC inputs as indicated in the diagram), or as true comparators.

The opamp inputs provide highly flexible connectivity and can connect directly to dedicated pins or, via the analog mux buses, to any pin on the chip. Analog switch connectivity is controllable by user firmware.

The opamps operate in Deep Sleep mode at very low currents allowing analog circuits to remain operational during Deep Sleep.

## Temperature Sensor

All SHM35920-M devices have one on-chip temperature sensor. This consists of a diode, which is biased by a current source that can be disabled to save power. The temperature sensor is connected to the ADC, which digitizes the reading and produces a temperature value using Cypress-supplied software that includes calibration and linearization.

## Low-power Comparators

The SHM35920-M devices have a pair of low-power comparators, which can also operate in the Deep Sleep and Hibernate modes. This allows the analog system blocks to be disabled while retaining the ability to monitor external voltage levels during low-power modes. The comparator outputs are normally synchronized to avoid meta-stability unless operating in an asynchronous power mode (Hibernate) where the system wake-up circuit is activated by a comparator switch event.

## Fixed Function Digital

### Timer/Counter/PWM (TCPWM) Block

The TCPWM block uses a 16-bit counter with user-programmable period length. There is a Capture register to record the count value at the time of an event (which may be an I/O event), a period register which is used to either stop or auto-reload the counter when its count is equal to the period register, and compare registers to generate compare value signals, which are used as PWM duty cycle outputs. The block also provides true and complementary outputs with programmable offset between them to allow use as deadband programmable complementary PWM outputs. It also has a Kill input to force outputs to a predetermined state; for example, this is used in motor drive systems when an overcurrent state is indicated and the PWMs driving the FETs need to be shut off immediately with no time for software intervention. The SHM35920-M has eight TCPWM blocks.

### Serial Communication Blocks (SCB)

The SHM35920-M has four SCBs, which can each implement an I<sup>2</sup>C, UART, or SPI interface.

**I<sup>2</sup>C Mode:** The hardware I<sup>2</sup>C block implements a full multi-master and slave interface (it is capable of multimaster arbitration). This block is capable of operating at speeds of up to 1 Mbps (Fast Mode Plus) and has flexible buffering options to reduce interrupt overhead and latency for the CPU. The I<sup>2</sup>C peripheral is also capable of supporting SMBus or PMBus interfaces. In addition, the block supports an 8-deep FIFO for receive and transmit which, by increasing the time given for the CPU to read data, greatly reduces the need for clock stretching caused by the CPU not having read data on time. The FIFO mode is available in all channels and is very useful in the absence of DMA.

The I<sup>2</sup>C peripheral is compatible with the I<sup>2</sup>C Standard-mode, Fast-mode, and Fast-mode Plus devices as defined in the NXP I<sup>2</sup>C-bus specification and user manual (UM10204). The I<sup>2</sup>C bus I/O is implemented with GPIO in open-drain modes.

**UART Mode:** This is a full-feature UART operating at up to 1 Mbps. It supports automotive single-wire interface (LIN), infrared interface (IrDA), and SmartCard (ISO7816) protocols, all of which are minor variants of the basic UART protocol. In addition, it supports the 9-bit multiprocessor mode that allows addressing of peripherals connected over common RX and TX lines. Common UART functions such as parity error, break detect, and frame error are supported. An 8-deep FIFO allows much greater CPU service latencies to be tolerated.

**SPI Mode:** The SPI mode supports full Motorola SPI, TI SSP (essentially adds a start pulse used to synchronize SPI Codex), and National Microwire (half-duplex form of SPI). The SPI block can use the FIFO and also supports an EzSPI mode in which data interchange is reduced to reading and writing an array in memory.

## GPIO

The SHM35920-M has 55 GPIOs in the 68-pin QFN package. The GPIO block implements the following:

- Eight drive strength modes including strong push-pull, resistive pull-up and pull-down, weak (resistive) pull-up and pull-down, open drain and open source, input only, and disabled
- Input threshold select (CMOS or LVTTTL)
- Individual control of input and output disables
- Hold mode for latching previous state (used for retaining I/O state in Deep Sleep mode and Hibernate modes)
- Selectable slew rates for dV/dt related noise control to improve EMI

The pins are organized in logical entities called ports, which are 8-bit in width. During power-on and reset, the blocks are forced to the disable state so as not to crowbar any inputs and/or cause excess turn-on current. A multiplexing network known as a high-speed I/O matrix is used to multiplex between various signals that may connect to an I/O pin. Pin locations for fixed-function peripherals are also fixed to reduce internal multiplexing complexity.

Data output and pin state registers store, respectively, the values to be driven on the pins and the states of the pins themselves.

Every I/O pin can generate an interrupt if so enabled and each I/O port has an interrupt request (IRQ) and interrupt service routine (ISR) vector associated with it (8 for SHM35920-M).

The Pins of Port 6 (up to 6 depending on the package) are overvoltage tolerant ( $V_{IN}$  can exceed  $V_{DD}$ ). The overvoltage cells will not sink more than 10  $\mu$ A when their inputs exceed  $V_{DDIO}$  in compliance with I<sup>2</sup>C specifications.

## Special Function Peripherals

### LCD Segment Drive

SHM35920-M has an LCD controller, which can drive up to four commons and up to 51 segments. Any pin can be either a common or a segment pin. It uses full digital methods to drive the LCD segments requiring no generation of internal LCD voltages. The two methods used are referred to as digital correlation and PWM.

Digital correlation pertains to modulating the frequency and levels of the common and segment signals to generate the highest RMS voltage across a segment to light it up or to keep the RMS signal zero. This method is good for STN displays but may result in reduced contrast with TN (cheaper) displays.

PWM pertains to driving the panel with PWM signals to effectively use the capacitance of the panel to provide the integration of the modulated pulse-width to generate the desired LCD voltage. This method results in higher power consumption but can result in better results when driving TN displays. LCD operation is supported during Deep Sleep refreshing a small display buffer (4 bits; 1 32-bit register per port).

### Pinouts

The following is the pin list for the SHM35920-M. This shows the power supply and port pins (for example, P0.0 is Pin 0 of Port 0).

68-QFN		68-QFN	
Pin	Name	Pin	Name
42	P0.0	7	P2.5
43	P0.1	8	P2.6
44	P0.2	9	P2.7
45	P0.3	10	VSSA
46	P0.4	11	VDDA
47	P0.5	12	P6.0
48	P0.6	13	P6.1
49	P0.7	14	P6.2
50	XRES	15	P6.3
51	VCCD	16	P6.4
52	VSSD	17	P6.5
53	VDDD	18	VSSIO
54	P5.0	19	P3.0
55	P5.1	20	P3.1
56	P5.2	21	P3.2
57	P5.3	22	P3.3
58	P5.4	23	P3.4
59	P5.5	24	P3.5
60	VDDA	25	P3.6
61	VSSA	26	P3.7
62	P1.0	27	VDDIO
63	P1.1	28	P4.0
64	P1.2	29	P4.1
65	P1.3	30	P4.2
66	P1.4	31	P4.3
67	P1.5	32	P4.4
68	P1.6	33	P4.5
1	P1.7/VREF	34	P4.6
2	P2.0	35	P4.7
3	P2.1	39	P7.0
4	P2.2	40	P7.1
5	P2.3	41	P7.2
6	P2.4		

The pins of Port 6 are overvoltage-tolerant. Pins 36, 37, and 38 are No-Connects on the 68-pin QFN. All VSS pins must be tied together.

The output drivers of I/O Ports P0 and P7 are connected to VDDD. Output drivers of I/O Ports 1, 2, and 5 are connected to VDDA. Output drivers of I/O Ports 3, 4, and 6 are connected to VDDIO.

Each of the pins shown in the previous table can have multiple programmable functions as shown in the following table. Column headings are functions:

Port/Pin	Analog	Alt. Function 1	Alt. Function 2	Alt. Function 3	Alt. Function 4
P0.0	lpcomp.in_p[0]				
P0.1	lpcomp.in_n[0]				
P0.2	lpcomp.in_p[1]				
P0.3	lpcomp.in_n[1]				
P0.4	wco_in		scb[1].uart_rx:0		scb[1].i2c_scl:0
P0.5	wco_out		scb[1].uart_tx:0		scb[1].i2c_sda:0
P0.6		ext_clk:0	scb[1].uart_cts:0		
P0.7			scb[1].uart_rts:0		wakeup
P5.0	ctb1.oa0.inp	tcpwm.line[4]:2	scb[2].uart_rx:0		scb[2].i2c_scl:0
P5.1	ctb1.oa0.inm	tcpwm.line_comp[4]:2	scb[2].uart_tx:0		scb[2].i2c_sda:0
P5.2	ctb1.oa0.out	tcpwm.line[5]:2	scb[2].uart_cts:0		lpcomp.comp[0]:1
P5.3	ctb1.oa1.out	tcpwm.line_comp[5]:2	scb[2].uart_rts:0		lpcomp.comp[1]:1
P5.4	ctb1.oa1.inm	tcpwm.line[6]:2			
P5.5	ctb1.oa1.inp	tcpwm.line_comp[6]:2			
P1.0	ctb0.oa0.inp	tcpwm.line[2]:1	scb[0].uart_rx:1		scb[0].i2c_scl:0
P1.1	ctb0.oa0.inm	tcpwm.line_comp[2]:1	scb[0].uart_tx:1		scb[0].i2c_sda:0
P1.2	ctb0.oa0.out	tcpwm.line[3]:1	scb[0].uart_cts:1		
P1.3	ctb0.oa1.out	tcpwm.line_comp[3]:1	scb[0].uart_rts:1		
P1.4	ctb0.oa1.inm	tcpwm.line[6]:1			
P1.5	ctb0.oa1.inp	tcpwm.line_comp[6]:1			
P1.6	ctb0.oa0.inp_alt	tcpwm.line[7]:1			
P1.7	ctb0.oa1.inp_alt	tcpwm.line_comp[7]:1			
P2.0	sarmux.0	tcpwm.line[4]:1			scb[1].i2c_scl:1
P2.1	sarmux.1	tcpwm.line_comp[4]:1			scb[1].i2c_sda:1
P2.2	sarmux.2	tcpwm.line[5]:1			
P2.3	sarmux.3	tcpwm.line_comp[5]:1			
P2.4	sarmux.4	tcpwm.line[0]:1			
P2.5	sarmux.5	tcpwm.line_comp[0]:1			
P2.6	sarmux.6	tcpwm.line[1]:1			
P2.7	sarmux.7	tcpwm.line_comp[1]:1			
P6.0		tcpwm.line[4]:0	scb[3].uart_rx:0		scb[3].i2c_scl:0
P6.1		tcpwm.line_comp[4]:0	scb[3].uart_tx:0		scb[3].i2c_sda:0

Port/Pin	Analog	Alt. Function 1	Alt. Function 2	Alt. Function 3	Alt. Function 4
P6.2		tcpwm.line[5]:0	scb[3].uart_cts:0		
P6.3		tcpwm.line_comp[5]:0	scb[3].uart_rts:0		
P6.4		tcpwm.line[6]:0			
P6.5		tcpwm.line_comp[6]:0			
P3.0		tcpwm.line[0]:0	scb[1].uart_rx:1		scb[1].i2c_scl:2
P3.1		tcpwm.line_comp[0]:0	scb[1].uart_tx:1		scb[1].i2c_sda:2
P3.2		tcpwm.line[1]:0	scb[1].uart_cts:1		swd_data
P3.3		tcpwm.line_comp[1]:0	scb[1].uart_rts:1		swd_clk
P3.4		tcpwm.line[2]:0			
P3.5		tcpwm.line_comp[2]:0			
P3.6		tcpwm.line[3]:0			
P3.7		tcpwm.line_comp[3]:0			
P4.0			scb[0].uart_rx:0		scb[0].i2c_scl:1
P4.1			scb[0].uart_tx:0		scb[0].i2c_sda:1
P4.2	csd[0].c_mod		scb[0].uart_cts:0		lpcmp.comp[0]:0
P4.3	csd[0].c_sh_tank		scb[0].uart_rts:0		lpcmp.comp[1]:0
P4.4					
P4.5					
P4.6					
P4.7					
P7.0		tcpwm.line[0]:2	scb[3].uart_rx:1		scb[3].i2c_scl:1
P7.1		tcpwm.line_comp[0]:2	scb[3].uart_tx:1		scb[3].i2c_sda:1
P7.2		tcpwm.line[1]:2	scb[3].uart_cts:1		

**Descriptions of the power pin functions are as follows:**

**VDDD**: Power supply for both analog and digital sections (where there is no  $V_{DDA}$  pin).

**VDDA**: Analog  $V_{DD}$  pin where package pins allow; shorted to  $V_{DDD}$  otherwise.

**VDDIO**: I/O pin power domain.

**VSSA**: Analog ground pin where package pins allow.

**VSS**: Ground pin.

**VCCD**: Regulated Digital supply (1.8 V  $\pm$ 5%).

Port Pins can all be used as LCD Commons, LCD S and shield pins can be connected to AMUXBUS A and pins that can be driven by firmware or DSI signals.

## Power

The supply voltage range is 1.71 to 5.5 V with all functions and circuits operating over that range.

The SHM35920-M family allows two distinct modes of power supply operation: Unregulated External Supply and Regulated External Supply modes.

### Unregulated External Supply

In this mode, the SHM35920-M is powered by an External Power Supply that can be anywhere in the range of 1.8 to 5.5 V. This range is also designed for battery-powered operation, for instance, the chip can be powered from a battery system that starts at 3.5V and works down to 1.8 V. In this mode, the internal regulator of the SHM35920-M supplies the internal logic and the VCCD output of the SHM35920-M must be bypassed to ground via an external Capacitor (in the range of 1 to 1.6  $\mu\text{F}$ ; X5R ceramic or better).

The grounds, VSSA and VSS, must be shorted together. Bypass capacitors must be used from VDDD and VDPA to ground, typical practice for systems in this frequency range is to use a capacitor in the 1  $\mu\text{F}$  range in parallel with a smaller capacitor (0.1  $\mu\text{F}$ , for example). Note that these are simply rules of thumb and that, for critical applications, the PCB layout, lead inductance, and the Bypass capacitor parasitic should be simulated to design and obtain optimal bypassing.

Power Supply	Bypass Capacitors
VDDD-VSS and VDDIO-VSS	0.1 $\mu\text{F}$ ceramic at each pin plus bulk capacitor 1 to 10 $\mu\text{F}$ .
VDPA-VSSA	0.1 $\mu\text{F}$ ceramic at pin. Additional 1 $\mu\text{F}$ to 10 $\mu\text{F}$ bulk capacitor
VCCD-VSS	1 $\mu\text{F}$ ceramic capacitor at the VCCD pin
VREF-VSSA (optional)	The internal bandgap may be bypassed with a 1 $\mu\text{F}$ to 10 $\mu\text{F}$ capacitor for better ADC performance.

### Regulated External Supply

In this mode, the SHM35920-M is powered by an external power supply that must be within the range of 1.71 to 1.89 V ( $1.8 \pm 5\%$ ); note that this range needs to include power supply ripple. VCCD and VDDD pins are shorted together and bypassed. The internal regulator is disabled in firmware.

## Development Support

The SHM35920-M family has a rich set of documentation, development tools, and online resources to assist you during your development process.

### Documentation

A suite of documentation supports the SHM35920-M family to ensure that you can find answers to your questions quickly. This section contains a list of some of the key documents.

**Software User Guide:** A step-by-step guide for using PSoC Creator. The software user guide shows you how the PSoC Creator build process works in detail, how to use source control with PSoC Creator, and much more.

**Component Datasheets:** The flexibility of PSoC allows the creation of new peripherals (components) long after the device has gone into production. Component data sheets provide all of the information needed to select and use a particular component, including a functional description, API documentation, example code, and AC/DC specifications.

**Application Notes:** PSoC application notes discuss a particular application of PSoC in depth; examples include temperature monitoring and on-chip filtering. Application notes often include example projects in addition to the application note document.

**Technical Reference Manual:** The Technical Reference Manual (TRM) contains all the technical detail you need to use a PSoC device, including a complete description of all PSoC registers.

### Online

In addition to print documentation, the Cypress PSoC forums connect you with fellow PSoC users and experts in PSoC from around the world, 24 hours a day, 7 days a week.

### Tools

With industry standard cores, programming, and debugging interfaces, the SHM35920-M family is part of a development tool ecosystem. Visit us at [www.cypress.com/go/psoccreator](http://www.cypress.com/go/psoccreator) for the latest information on the revolutionary, easy to use PSoC Creator IDE, supported third party compilers, programmers, debuggers, and development kits.

## Electrical Specifications

### Absolute Maximum Ratings

**Table 1. Absolute Maximum Ratings<sup>[1]</sup>**

Spec ID#	Parameter	Description	Min	Typ	Max	Units	Details/Conditions
SID1	V <sub>DD_ABS</sub>	Analog or digital supply relative to V <sub>SS</sub> (V <sub>SSD</sub> = V <sub>SSA</sub> )	-0.5	-	6	V	Absolute maximum
SID2	V <sub>CCD_ABS</sub>	Direct digital core voltage input relative to V <sub>SSD</sub>	-0.5	-	1.95	V	Absolute maximum
SID3	V <sub>GPIO_ABS</sub>	GPIO voltage; V <sub>DDD</sub> or V <sub>DDA</sub>	-0.5	-	V <sub>DD</sub> +0.5	V	Absolute maximum
SID4	I <sub>GPIO_ABS</sub>	Current per GPIO	-25	-	25	mA	Absolute maximum
SID5	I <sub>G-PIO_injection</sub>	GPIO injection current per pin	-0.5	-	0.5	mA	Absolute maximum
BID44	ESD_HBM	Electrostatic discharge human body model	2200	-	-	V	
BID45	ESD_CDM	Electrostatic discharge charged device model	500	-	-	V	
BID46	LU	Pin current for latch-up	-140	-	140	mA	

### Device Level Specifications

All specifications are valid for -40 °C ≤ TA ≤ 105 °C and TJ ≤ 125 °C, except where noted. Specifications are valid for 1.71 V to 5.5 V, except where noted.

**Table 2. DC Specifications**

Spec ID#	Parameter	Description	Min	Typ	Max	Units	Details / Conditions
SID53	V <sub>DD</sub>	Power Supply Input Voltage (V <sub>DDA</sub> = V <sub>DDD</sub> = V <sub>DD</sub> )	1.8	-	5.5	V	With regulator enabled
SID255	V <sub>DDD</sub>	Power Supply Input Voltage unregulated	1.71	1.8	1.89	V	Internally unregulated Supply
SID54	V <sub>CCD</sub>	Output voltage (for core logic)	-	1.8	-	V	
SID55	C <sub>EFC</sub>	External Regulator voltage bypass	1	1.3	1.6	μF	X5R ceramic or better
SID56	C <sub>EXC</sub>	Power supply decoupling capacitor	-	1	-	μF	X5R ceramic or better
<b>Active Mode, V<sub>DD</sub> = 1.71 V to 5.5 V, -40 °C to +105 °C</b>							
SID6	I <sub>DD1</sub>	Execute from Flash; CPU at 6 MHz	-	2.2	2.8	mA	
SID7	I <sub>DD2</sub>	Execute from Flash; CPU at 12 MHz	-	3.7	4.2	mA	
SID8	I <sub>DD3</sub>	Execute from Flash; CPU at 24 MHz	-	6.7	7.2	mA	
<b>Sleep Mode, -40 °C to +105 °C</b>							
SID21	I <sub>DD16</sub>	I <sup>2</sup> C wakeup, WDT, and Comparators on. Regulator Off.	-	1.75	2.1	mA	V <sub>DD</sub> = 1.71 to 1.89, 6 MHz
SID22	I <sub>DD17</sub>	I <sup>2</sup> C wakeup, WDT, and Comparators on.	-	1.7	2.1	mA	V <sub>DD</sub> = 1.8 to 5.5, 6 MHz
SID23	I <sub>DD18</sub>	I <sup>2</sup> C wakeup, WDT, and Comparators on. Regulator Off.	-	2.35	2.8	mA	V <sub>DD</sub> = 1.71 to 1.89, 12 MHz
SID24	I <sub>DD19</sub>	I <sup>2</sup> C wakeup, WDT, and Comparators on.	-	2.25	2.8	mA	V <sub>DD</sub> = 1.8 to 5.5, 12 MHz

**Note**

- Usage above the absolute maximum conditions listed in Table 1 may cause permanent damage to the device. Exposure to absolute maximum conditions for extended periods of time may affect device reliability. The maximum storage temperature is 150 °C in compliance with JEDEC Standard JESD22-A103, High Temperature Storage Life. When used below absolute maximum conditions but above normal operating conditions, the device may not operate to specification.

**Table 2. DC Specifications** (continued)

Spec ID#	Parameter	Description	Min	Typ	Max	Units	Details / Conditions
<b>Deep Sleep Mode, -40 °C to + 60 °C</b>							
SID30	I <sub>DD25</sub>	I <sup>2</sup> C wakeup and WDT on. Regulator Off.	–	1.55	20	μA	V <sub>DD</sub> = 1.71 to 1.89
SID31	I <sub>DD26</sub>	I <sup>2</sup> C wakeup and WDT on.	–	1.35	15	μA	V <sub>DD</sub> = 1.8 to 3.6
SID32	I <sub>DD27</sub>	I <sup>2</sup> C wakeup and WDT on.	–	1.5	15	μA	V <sub>DD</sub> = 3.6 to 5.5
<b>Deep Sleep Mode, +85 °C</b>							
SID33	I <sub>DD28</sub>	I <sup>2</sup> C wakeup and WDT on. Regulator Off.	–	–	60	μA	V <sub>DD</sub> = 1.71 to 1.89
SID34	I <sub>DD29</sub>	I <sup>2</sup> C wakeup and WDT on.	–	–	45	μA	V <sub>DD</sub> = 1.8 to 3.6
SID35	I <sub>DD30</sub>	I <sup>2</sup> C wakeup and WDT on.	–	–	30	μA	V <sub>DD</sub> = 3.6 to 5.5
<b>Deep Sleep Mode, +105 °C</b>							
SID33Q	I <sub>DD28Q</sub>	I <sup>2</sup> C wakeup and WDT on. Regulator Off.	–	–	135	μA	V <sub>DD</sub> = 1.71 to 1.89
SID34Q	I <sub>DD29Q</sub>	I <sup>2</sup> C wakeup and WDT on.	–	–	180	μA	V <sub>DD</sub> = 1.8 to 3.6
SID35Q	I <sub>DD30Q</sub>	I <sup>2</sup> C wakeup and WDT on.	–	–	140	μA	V <sub>DD</sub> = 3.6 to 5.5
<b>Hibernate Mode, -40 °C to + 60 °C</b>							
SID39	I <sub>DD34</sub>	Regulator Off.	–	150	3000	nA	V <sub>DD</sub> = 1.71 to 1.89
SID40	I <sub>DD35</sub>		–	150	1000	nA	V <sub>DD</sub> = 1.8 to 3.6
SID41	I <sub>DD36</sub>		–	150	1100	nA	V <sub>DD</sub> = 3.6 to 5.5
<b>Hibernate Mode, +85 °C</b>							
SID42	I <sub>DD37</sub>	Regulator Off.	–	–	4500	nA	V <sub>DD</sub> = 1.71 to 1.89
SID43	I <sub>DD38</sub>		–	–	3500	nA	V <sub>DD</sub> = 1.8 to 3.6
SID44	I <sub>DD39</sub>		–	–	3500	nA	V <sub>DD</sub> = 3.6 to 5.5
<b>Hibernate Mode, +105 °C</b>							
SID42Q	I <sub>DD37Q</sub>	Regulator Off.	–	–	19.4	μA	V <sub>DD</sub> = 1.71 to 1.89
SID43Q	I <sub>DD38Q</sub>		–	–	17	μA	V <sub>DD</sub> = 1.8 to 3.6
SID44Q	I <sub>DD39Q</sub>		–	–	16	μA	V <sub>DD</sub> = 3.6 to 5.5
<b>Stop Mode, +85 °C</b>							
SID304	I <sub>DD43A</sub>	Stop Mode current; V <sub>DD</sub> = 3.6 V	–	35	85	nA	T = -40 °C to +60 °C
SID304A	I <sub>DD43B</sub>	Stop Mode current; V <sub>DD</sub> = 3.6 V	–	–	1450	nA	T = +85 °C
<b>Stop Mode, +105 °C</b>							
SID304Q	I <sub>DD43AQ</sub>	Stop Mode current; V <sub>DD</sub> = 3.6 V	–	–	5645	nA	
<b>XRES current</b>							
SID307	I <sub>DD_XR</sub>	Supply current while XRES asserted	–	2	5	mA	

**Table 3. AC Specifications**

Spec ID#	Parameter	Description	Min	Typ	Max	Units	Details/ Conditions
SID48	F <sub>CPU</sub>	CPU frequency	DC	–	24	MHz	1.71 ≤ V <sub>DD</sub> ≤ 5.5
SID49	T <sub>SLEEP</sub>	Wakeup from sleep mode	–	0	–	μs	Guaranteed by characterization
SID50	T <sub>DEEPSLEEP</sub>	Wakeup from Deep Sleep mode	–	–	25	μs	24 MHz IMO. Guaranteed by characterization
SID51	T <sub>HIBERNATE</sub>	Wakeup from Hibernate mode	–	–	0.7	ms	Guaranteed by characterization
SID51A	T <sub>STOP</sub>	Wakeup from Stop mode	–	–	2	ms	Guaranteed by characterization
SID52	T <sub>RESETWIDTH</sub>	External reset pulse width	1	–	–	μs	Guaranteed by characterization

**GPIO**
**Table 4. GPIO DC Specifications**

Spec ID#	Parameter	Description	Min	Typ	Max	Units	Details/ Conditions
SID57	V <sub>IH</sub> <sup>[2]</sup>	Input voltage high threshold	0.7 × V <sub>DDD</sub>	–	–	V	CMOS Input
SID57A	I <sub>IHS</sub>	Input current when Pad > V <sub>DDIO</sub> for OVT inputs	–	–	10	μA	Per I <sup>2</sup> C Spec
SID58	V <sub>IL</sub>	Input voltage low threshold	–	–	0.3 × V <sub>DDD</sub>	V	CMOS Input
SID241	V <sub>IH</sub> <sup>[2]</sup>	LVTTL input, V <sub>DDD</sub> < 2.7 V	0.7 × V <sub>DDD</sub>	–	–	V	
SID242	V <sub>IL</sub>	LVTTL input, V <sub>DDD</sub> < 2.7 V	–	–	0.3 × V <sub>DDD</sub>	V	
SID243	V <sub>IH</sub> <sup>[2]</sup>	LVTTL input, V <sub>DDD</sub> ≥ 2.7 V	2.0	–	–	V	
SID244	V <sub>IL</sub>	LVTTL input, V <sub>DDD</sub> ≥ 2.7 V	–	–	0.8	V	
SID59	V <sub>OH</sub>	Output voltage high level	V <sub>DDD</sub> – 0.6	–	–	V	I <sub>OH</sub> = 4 mA at 3 V V <sub>DDD</sub>
SID60	V <sub>OH</sub>	Output voltage high level	V <sub>DDD</sub> – 0.5	–	–	V	I <sub>OH</sub> = 1 mA at 1.8 V V <sub>DDD</sub>
SID61	V <sub>OL</sub>	Output voltage low level	–	–	0.6	V	I <sub>OL</sub> = 4 mA at 1.8 V V <sub>DDD</sub>
SID62	V <sub>OL</sub>	Output voltage low level	–	–	0.6	V	I <sub>OL</sub> = 8 mA at 3 V V <sub>DDD</sub>
SID62A	V <sub>OL</sub>	Output voltage low level	–	–	0.4	V	I <sub>OL</sub> = 3 mA at 3 V V <sub>DDD</sub>
SID63	R <sub>PULLUP</sub>	Pull-up resistor	3.5	5.6	8.5	kΩ	
SID64	R <sub>PULLDOWN</sub>	Pull-down resistor	3.5	5.6	8.5	kΩ	
SID65	I <sub>IL</sub>	Input leakage current (absolute value)	–	–	2	nA	25 °C, V <sub>DDD</sub> = 3.0 V. Guaranteed by characterization

**Note**

 2. V<sub>IH</sub> must not exceed V<sub>DDD</sub> + 0.2 V.

**Table 4. GPIO DC Specifications** (continued)

Spec ID#	Parameter	Description	Min	Typ	Max	Units	Details/ Conditions
SID65A	$I_{IL\_CTBM}$	Input leakage current (absolute value) for CTBM pins	–	–	4	nA	Guaranteed by characterization
SID66	$C_{IN}$	Input capacitance	–	–	7	pF	
SID67	$V_{HYSTTL}$	Input hysteresis LVTTTL	25	40	–	mV	$V_{DDD} \geq 2.7\text{ V}$
SID68	$V_{HYSCMOS}$	Input hysteresis CMOS	$0.05 \times V_{DDD}$	–	–	mV	
SID69	$I_{DIODE}$	Current through protection diode to $V_{DD}/V_{SS}$	–	–	100	$\mu\text{A}$	Guaranteed by characterization
SID69A	$I_{TOT\_GPIO}$	Maximum Total Source or Sink Chip Current	–	–	200	mA	Guaranteed by characterization

**Table 5. GPIO AC Specifications**  
(Guaranteed by Characterization)<sup>[3]</sup>

Spec ID#	Parameter	Description	Min	Typ	Max	Units	Details/ Conditions
SID70	$T_{RISEF}$	Rise time in fast strong mode	2	–	12	ns	3.3 V $V_{DDD}$ , Load = 25 pF
SID71	$T_{FALLF}$	Fall time in fast strong mode	2	–	12	ns	3.3 V $V_{DDD}$ , Load = 25 pF
SID72	$T_{RISES}$	Rise time in slow strong mode	10	–	60	ns	3.3 V $V_{DDD}$ , Load = 25 pF
SID73	$T_{FALLS}$	Fall time in slow strong mode	10	–	60	ns	3.3 V $V_{DDD}$ , Load = 25 pF
SID74	$F_{GPIOUT1}$	GPIO Fout; 3.3 V $\leq V_{DDD} \leq 5.5\text{ V}$ . Fast strong mode.	–	–	24	MHz	90/10%, 25 pF load, 60/40 duty cycle
SID75	$F_{GPIOUT2}$	GPIO Fout; 1.7 V $\leq V_{DDD} \leq 3.3\text{ V}$ . Fast strong mode.	–	–	16.7	MHz	90/10%, 25 pF load, 60/40 duty cycle
SID76	$F_{GPIOUT3}$	GPIO Fout; 3.3 V $\leq V_{DDD} \leq 5.5\text{ V}$ . Slow strong mode.	–	–	7	MHz	90/10%, 25 pF load, 60/40 duty cycle
SID245	$F_{GPIOUT4}$	GPIO Fout; 1.7 V $\leq V_{DDD} \leq 3.3\text{ V}$ . Slow strong mode.	–	–	3.5	MHz	90/10%, 25 pF load, 60/40 duty cycle
SID246	$F_{GPIOIN}$	GPIO input operating frequency; 1.71 V $\leq V_{DDD} \leq 5.5\text{ V}$	–	–	48	MHz	90/10% $V_{IO}$

**Note**

3. Simultaneous switching transitions on many fully-loaded GPIO pins may cause ground perturbations depending on several factors including PCB and decoupling capacitor design. For applications that are very sensitive to ground perturbations, the slower GPIO slew rate setting may be used.

XRES

**Table 6. XRES DC Specifications**

Spec ID#	Parameter	Description	Min	Typ	Max	Units	Details/ Conditions
SID77	$V_{IH}$	Input voltage high threshold	$0.7 \times V_{DD}$	–	–	V	CMOS Input
SID78	$V_{IL}$	Input voltage low threshold	–	–	$0.3 \times V_{DD}$	V	CMOS Input
SID79	$R_{PULLUP}$	Pull-up resistor	3.5	5.6	8.5	k $\Omega$	
SID80	$C_{IN}$	Input capacitance	–	3	–	pF	
SID81	$V_{HYSXRES}$	Input voltage hysteresis	–	100	–	mV	Guaranteed by characterization
SID82	$I_{DIODE}$	Current through protection diode to $V_{DD}/V_{SS}$	–	–	100	$\mu$ A	Guaranteed by characterization

**Table 7. XRES AC Specifications**

Spec ID#	Parameter	Description	Min	Typ	Max	Units	Details/ Conditions
SID83	$T_{RESETWIDTH}$	Reset pulse width	1	–	–	$\mu$ s	Guaranteed by characterization

**Analog Peripherals**
*Opamp*
**Table 8. Opamp Specifications**

(Guaranteed by Characterization)

Spec ID#	Parameter	Description	Min	Typ	Max	Units	Details/ Conditions
	I <sub>DD</sub>	Opamp block current. No load.	–	–	–	–	
SID269	I <sub>DD_HI</sub>	Power = high	–	1100	1850	μA	
SID270	I <sub>DD_MED</sub>	Power = medium	–	550	950	μA	
SID271	I <sub>DD_LOW</sub>	Power = low	–	150	350	μA	
	GBW	Load = 20 pF, 0.1 mA. V <sub>DDA</sub> = 2.7 V	–	–	–	–	
SID272	GBW_HI	Power = high	6	–	–	MHz	
SID273	GBW_MED	Power = medium	4	–	–	MHz	
SID274	GBW_LO	Power = low	–	1	–	MHz	
	I <sub>OUT_MAX</sub>	V <sub>DDA</sub> ≥ 2.7 V, 500 mV from rail	–	–	–	–	
SID275	I <sub>OUT_MAX_HI</sub>	Power = high	10	–	–	mA	
SID276	I <sub>OUT_MAX_MID</sub>	Power = medium	10	–	–	mA	
SID277	I <sub>OUT_MAX_LO</sub>	Power = low	–	5	–	mA	
	I <sub>OUT</sub>	V <sub>DDA</sub> = 1.71 V, 500 mV from rail	–	–	–	–	
SID278	I <sub>OUT_MAX_HI</sub>	Power = high	4	–	–	mA	
SID279	I <sub>OUT_MAX_MID</sub>	Power = medium	4	–	–	mA	
SID280	I <sub>OUT_MAX_LO</sub>	Power = low	–	2	–	mA	
SID281	V <sub>IN</sub>	Input voltage range	–0.05	–	V <sub>DDA</sub> – 0.2	V	Charge-pump on, V <sub>DDA</sub> ≥ 2.7 V
SID282	V <sub>CM</sub>	Input common mode voltage	–0.05	–	V <sub>DDA</sub> – 0.2	V	Charge-pump on, V <sub>DDA</sub> ≥ 2.7 V
	V <sub>OUT</sub>	V <sub>DDA</sub> ≥ 2.7 V	–	–	–		
SID283	V <sub>OUT_1</sub>	Power = high, I <sub>load</sub> =10 mA	0.5	–	V <sub>DDA</sub> – 0.5	V	
SID284	V <sub>OUT_2</sub>	Power = high, I <sub>load</sub> =1 mA	0.2	–	V <sub>DDA</sub> – 0.2	V	
SID285	V <sub>OUT_3</sub>	Power = medium, I <sub>load</sub> =1 mA	0.2	–	V <sub>DDA</sub> – 0.2	V	
SID286	V <sub>OUT_4</sub>	Power = low, I <sub>load</sub> =0.1 mA	0.2	–	V <sub>DDA</sub> – 0.2	V	
SID288	V <sub>OS_TR</sub>	Offset voltage, trimmed	1	±0.5	1	mV	High mode
SID288A	V <sub>OS_TR</sub>	Offset voltage, trimmed	–	±1	–	mV	Medium mode
SID288B	V <sub>OS_TR</sub>	Offset voltage, trimmed	–	±2	–	mV	Low mode
SID290	V <sub>OS_DR_TR</sub>	Offset voltage drift, trimmed	–10	±3	10	μV/°C	High mode. T <sub>A</sub> ≤ 85 °C.
SID290Q	V <sub>OS_DR_TR</sub>	Offset voltage drift, trimmed	15	±3	15	μV/°C	High mode. T <sub>A</sub> ≤ 105 °C
SID290A	V <sub>OS_DR_TR</sub>	Offset voltage drift, trimmed	–	±10	–	μV/°C	Medium mode
SID290B	V <sub>OS_DR_TR</sub>	Offset voltage drift, trimmed	–	±10	–	μV/°C	Low mode
SID291	CMRR	DC Common mode rejection ratio. High-power mode. Common Mode voltage range from 0.5 V to V <sub>DDA</sub> – 0.5 V.	60	70	–	dB	V <sub>DD</sub> = 3.6 V
SID292	PSRR	At 1 kHz, 100-mV ripple	70	85	–	dB	V <sub>DD</sub> = 3.6 V
	Noise		–	–	–	–	

**Table 8. Opamp Specifications**

(Guaranteed by Characterization) (continued)

Spec ID#	Parameter	Description	Min	Typ	Max	Units	Details/ Conditions
SID293	V <sub>N1</sub>	Input referred, 1 Hz - 1GHz, power = high	–	94	–	μVrms	
SID294	V <sub>N2</sub>	Input referred, 1 kHz, power = high	–	72	–	nV/rtHz	
SID295	V <sub>N3</sub>	Input referred, 10kHz, power = high	–	28	–	nV/rtHz	
SID296	V <sub>N4</sub>	Input referred, 100kHz, power = high	–	15	–	nV/rtHz	
SID297	Cl <sub>oad</sub>	Stable up to maximum load. Performance specs at 50 pF.	–	–	125	pF	
SID298	Slew <sub>rate</sub>	Cl <sub>oad</sub> = 50 pF, Power = High, V <sub>D<sub>DA</sub></sub> ≥ 2.7 V	6	–	–	V/μs	
SID299	T <sub>op_wake</sub>	From disable to enable, no external RC dominating	–	25	–	μs	
SID299A	OL <sub>GAIN</sub>	Open Loop Gain	–	90	–	dB	
	Comp <sub>mode</sub>	Comparator mode; 50 mV drive, Trise = Tfall (approx.)	–	–	–		
SID300	T <sub>PD1</sub>	Response time; power = high	–	150	–	ns	
SID301	T <sub>PD2</sub>	Response time; power = medium	–	400	–	ns	
SID302	T <sub>PD3</sub>	Response time; power = low	–	2000	–	ns	
SID303	V <sub>hyst_op</sub>	Hysteresis	–	10	–	mV	
<b>Deep Sleep Mode</b>		Mode 2 is lowest current range. Mode 1 has higher GBW.					Deep Sleep mode. V <sub>D<sub>DA</sub></sub> ≥ 2.7 V.
SID_DS_1	ID <sub>D_HI_M1</sub>	Mode 1, High current	–	1400	–	uA	25 °C
SID_DS_2	ID <sub>D_MED_M1</sub>	Mode 1, Medium current	–	700	–	uA	25 °C
SID_DS_3	ID <sub>D_LOW_M1</sub>	Mode 1, Low current	–	200	–	uA	25 °C
SID_DS_4	ID <sub>D_HI_M2</sub>	Mode 2, High current	–	120	–	uA	25 °C
SID_DS_5	ID <sub>D_MED_M2</sub>	Mode 2, Medium current	–	60	–	uA	25 °C
SID_DS_6	ID <sub>D_LOW_M2</sub>	Mode 2, Low current	–	15	–	uA	25 °C
SID_DS_7	GBW <sub>HI_M1</sub>	Mode 1, High current	–	4	–	MHz	25 °C
SID_DS_8	GBW <sub>MED_M1</sub>	Mode 1, Medium current	–	2	–	MHz	25 °C
SID_DS_9	GBW <sub>LOW_M1</sub>	Mode 1, Low current	–	0.5	–	MHz	25 °C
SID_DS_10	GBW <sub>HI_M2</sub>	Mode 2, High current	–	0.5	–	MHz	20-pF load, no DC load 0.2 V to V <sub>D<sub>DA</sub></sub> -1.5 V
SID_DS_11	GBW <sub>MED_M2</sub>	Mode 2, Medium current	–	0.2	–	MHz	20-pF load, no DC load 0.2 V to V <sub>D<sub>DA</sub></sub> -1.5 V
SID_DS_12	GBW <sub>LOW_M2</sub>	Mode 2, Low current	–	0.1	–	MHz	20-pF load, no DC load 0.2 V to V <sub>D<sub>DA</sub></sub> -1.5 V
SID_DS_13	VOS <sub>HI_M1</sub>	Mode 1, High current	–	5	–	mV	With trim 25 °C, 0.2 V to V <sub>D<sub>DA</sub></sub> -1.5 V
SID_DS_14	VOS <sub>MED_M1</sub>	Mode 1, Medium current	–	5	–	mV	With trim 25 °C, 0.2 V to V <sub>D<sub>DA</sub></sub> -1.5 V
SID_DS_15	VOS <sub>LOW_M1</sub>	Mode 1, Low current	–	5	–	mV	With trim 25 °C, 0.2 V to V <sub>D<sub>DA</sub></sub> -1.5 V
SID_DS_16	VOS <sub>HI_M2</sub>	Mode 2, High current	–	5	–	mV	With trim 25 °C, 0.2 V to V <sub>D<sub>DA</sub></sub> -1.5 V
SID_DS_17	VOS <sub>MED_M2</sub>	Mode 2, Medium current	–	5	–	mV	With trim 25 °C, 0.2 V to V <sub>D<sub>DA</sub></sub> -1.5 V

**Table 8. Opamp Specifications**

(Guaranteed by Characterization) (continued)

Spec ID#	Parameter	Description	Min	Typ	Max	Units	Details/ Conditions
SID_DS_18	VOS_LOW_M2	Mode 2, Low current	–	5	–	mV	With trim 25 °C, 0.2 V to $V_{DDA}-1.5$ V
SID_DS_19	IOUT_HI_M1	Mode 1, High current	–	10	–	mA	Output is 0.5 V to $V_{DDA}-0.5$ V
SID_DS_20	IOUT_MED_M1	Mode 1, Medium current	–	10	–	mA	Output is 0.5 V to $V_{DDA}-0.5$ V
SID_DS_21	IOUT_LOW_M1	Mode 1, Low current	–	4	–	mA	Output is 0.5 V to $V_{DDA}-0.5$ V
SID_DS_22	IOUT_HI_M2	Mode 2, High current	–	1	–	mA	Output is 0.5 V to $V_{DDA}-0.5$ V
SID_DS_23	IOUT_MED_M2	Mode 2, Medium current	–	1	–	mA	Output is 0.5 V to $V_{DDA}-0.5$ V
SID_DS_24	IOUT_LOW_M2	Mode 2, Low current	–	0.5	–	mA	Output is 0.5 V to $V_{DDA}-0.5$ V

### Comparator

**Table 9. Comparator DC Specifications**

Spec ID#	Parameter	Description	Min	Typ	Max	Units	Details/ Conditions
SID85	$V_{\text{OFFSET}2}$	Input offset voltage, Common Mode voltage range from 0 to $V_{DD}-1$	–	–	$\pm 4$	mV	
SID85A	$V_{\text{OFFSET}3}$	Input offset voltage. Ultra low-power mode ( $V_{DD} \geq 2.2$ V for Temp < 0 °C, $V_{DD} \geq 1.8$ V for Temp > 0 °C).	–	$\pm 12$	–	mV	
SID86	$V_{\text{HYST}}$	Hysteresis when enabled, Common Mode voltage range from 0 to $V_{DD}-1$ .	–	10	35	mV	Guaranteed by characterization
SID87	$V_{\text{ICM}1}$	Input common mode voltage in normal mode	0	–	$V_{DD}-0.1$	V	Modes 1 and 2.
SID247	$V_{\text{ICM}2}$	Input common mode voltage in low power mode	0	–	$V_{DD}$	V	
SID247A	$V_{\text{ICM}3}$	Input common mode voltage in ultra low power mode ( $V_{DD} \geq 2.2$ V for Temp < 0 °C, $V_{DD} \geq 1.8$ V for Temp > 0 °C)	0	–	$V_{DD}-1.15$	V	
SID88	CMRR	Common mode rejection ratio	50	–	–	dB	$V_{DD} \geq 2.7$ V. Guaranteed by characterization
SID88A	CMRR	Common mode rejection ratio	42	–	–	dB	$V_{DD} < 2.7$ V. Guaranteed by characterization
SID89	$I_{\text{CMP}1}$	Block current, normal mode	–	–	400	$\mu\text{A}$	Guaranteed by characterization
SID248	$I_{\text{CMP}2}$	Block current, low power mode	–	–	100	$\mu\text{A}$	Guaranteed by characterization
SID259	$I_{\text{CMP}3}$	Block current, ultra low power mode ( $V_{DD} \geq 2.2$ V for Temp < 0 °C, $V_{DD} \geq 1.8$ V for Temp > 0 °C)	–	6	28	$\mu\text{A}$	Guaranteed by characterization
SID90	$Z_{\text{CMP}}$	DC input impedance of comparator	35	–	–	M $\Omega$	Guaranteed by characterization

**Table 10. Comparator AC Specifications**

(Guaranteed by Characterization)

Spec ID#	Parameter	Description	Min	Typ	Max	Units	Details/Conditions
SID91	T <sub>RESP1</sub>	Response time, normal mode	–	–	110	ns	50-mV overdrive
SID258	T <sub>RESP2</sub>	Response time, low power mode	–	–	200	ns	50-mV overdrive
SID92	T <sub>RESP3</sub>	Response time, ultra low power mode (V <sub>DDD</sub> ≥ 2.2 V for Temp < 0 °C, V <sub>DDD</sub> ≥ 1.8 V for Temp > 0 °C)	–	–	15	µs	200-mV overdrive

*Temperature Sensor*
**Table 11. Temperature Sensor Specifications**

Spec ID#	Parameter	Description	Min	Typ	Max	Units	Details/Conditions
SID93	T <sub>SENSACC</sub>	Temperature sensor accuracy	–5	±1	+5	°C	–40 to +85 °C

*SAR ADC*
**Table 12. SAR ADC DC Specifications**

Spec ID#	Parameter	Description	Min	Typ	Max	Units	Details/Conditions
SID94	A_RES	Resolution	–	–	12	bits	
SID95	A_CHNIS_S	Number of channels - single ended	–	–	16		8 full speed
SID96	A-CHNKS_D	Number of channels - differential	–	–	8		Diff inputs use neighboring I/O
SID97	A-MONO	Monotonicity	–	–	–		Yes. Based on characterization
SID98	A_GAINERR	Gain error	–	–	±0.1	%	With external reference.
SID99	A_OFFSET	Input offset voltage	–	–	2	mV	Measured with 1-V V <sub>REF</sub> .
SID100	A_ISAR	Current consumption	–	–	1	mA	
SID101	A_VINS	Input voltage range - single ended	V <sub>SS</sub>	–	V <sub>DDA</sub>	V	Based on device characterization
SID102	A_VIND	Input voltage range - differential	V <sub>SS</sub>	–	V <sub>DDA</sub>	V	Based on device characterization
SID103	A_INRES	Input resistance	–	–	2.2	KΩ	Based on device characterization
SID104	A_INCAP	Input capacitance	–	–	10	pF	Based on device characterization

**Table 13. SAR ADC AC Specifications**

(Guaranteed by Characterization)

Spec ID#	Parameter	Description	Min	Typ	Max	Units	Details/Conditions
SID106	A_PSR	Power supply rejection ratio	70	–	–	dB	
SID107	A_CMRR	Common mode rejection ratio	66	–	–	dB	Measured at 1 V
SID108	A_SAMP_1	Sample rate with external reference bypass cap	–	–	806	ksps	

**Table 13. SAR ADC AC Specifications**

(Guaranteed by Characterization) (continued)

Spec ID#	Parameter	Description	Min	Typ	Max	Units	Details/Conditions
SID108A	A_SAMP_2	Sample rate with no bypass cap. Reference = $V_{DD}$	–	–	500	ksps	
SID108B	A_SAMP_3	Sample rate with no bypass cap. Internal reference	–	–	100	ksps	
SID109	A_SNDR	Signal-to-noise and distortion ratio (SINAD)	66	–	–	dB	$F_{IN} = 10 \text{ kHz}$
SID111	A_INL	Integral non linearity	–1.4	–	+1.4	LSB	$V_{DD} = 1.71 \text{ to } 5.5$ , 806 Ksps, $V_{ref} = 1 \text{ to } 5.5$ .
SID111A	A_INL	Integral non linearity	–1.4	–	+1.4	LSB	$V_{DDD} = 1.71 \text{ to } 3.6$ , 806 Ksps, $V_{ref} = 1.71 \text{ to } V_{DDD}$ .
SID111B	A_INL	Integral non linearity	–1.4	–	+1.4	LSB	$V_{DDD} = 1.71 \text{ to } 5.5$ , 500 Ksps, $V_{ref} = 1 \text{ to } 5.5$ .
SID112	A_DNL	Differential non linearity	–0.9	–	+1.35	LSB	$V_{DDD} = 1.71 \text{ to } 5.5$ , 806 Ksps, $V_{ref} = 1 \text{ to } 5.5$ .
SID112A	A_DNL	Differential non linearity	–0.9	–	+1.35	LSB	$V_{DDD} = 1.71 \text{ to } 3.6$ , 806 Ksps, $V_{ref} = 1.71 \text{ to } V_{DDD}$ .
SID112B	A_DNL	Differential non linearity	–0.9	–	+1.35	LSB	$V_{DDD} = 1.71 \text{ to } 5.5$ , 500 Ksps, $V_{ref} = 1 \text{ to } 5.5$ .
SID113	A_THD	Total harmonic distortion	–	–	–65	dB	$F_{IN} = 10 \text{ kHz}$ .

CSD

**Table 14. IDAC Specification**

Spec ID#	Parameter	Description	Min	Typ	Max	Units	Details/Conditions
<b>CSD Specification</b>							
SID309	IDAC1	DNL for 8-bit resolution	–1	–	1	LSB	
SID310	IDAC1	INL for 8-bit resolution	–3	–	3	LSB	
SID311	IDAC2	DNL for 7-bit resolution	–1	–	1	LSB	
SID312	IDAC2	INL for 7-bit resolution	–3	–	3	LSB	
SID314	IDAC1_CRT1	Output current of Idac1 (8-bits) in High range	–	612	–	$\mu\text{A}$	
SID314A	IDAC1_CRT2	Output current of Idac1(8-bits) in Low range	–	306	–	$\mu\text{A}$	
SID315	IDAC2_CRT1	Output current of Idac2 (7-bits) in High range	–	304.8	–	$\mu\text{A}$	
SID315A	IDAC2_CRT2	Output current of Idac2 (7-bits) in Low range	–	152.4	–	$\mu\text{A}$	

## Digital Peripherals

The following specifications apply to the Timer/Counter/PWM peripheral in timer mode.

*Timer/Counter/PWM*

**Table 15. TCPWM Specifications**

(Guaranteed by Characterization)

Spec ID#	Parameter	Description	Min	Typ	Max	Units	Details/Conditions
SID.TCPWM.1	ITCPWM1	Block current consumption at 3 MHz	–	–	45	μA	All modes (Timer/Counter/PWM)
SID.TCPWM.2	ITCPWM2	Block current consumption at 12 MHz	–	–	155	μA	All modes (Timer/Counter/PWM)
SID.TCPWM.2A	ITCPWM3	Block current consumption at 48 MHz	–	–	650	μA	All modes (Timer/Counter/PWM)
SID.TCPWM.3	TCPWMFREQ	Operating frequency	–	–	F <sub>c</sub>	MHz	F <sub>c</sub> max = F <sub>cpu</sub> . Maximum = 24 MHz
SID.TCPWM.4	TPWMENEXT	Input Trigger Pulse Width for all Trigger Events	2/F <sub>c</sub>	–	–	ns	Trigger Events can be Stop, Start, Reload, Count, Capture, or Kill depending on which mode of operation is selected.
SID.TCPWM.5	TPWMEXT	Output Trigger Pulse widths	2/F <sub>c</sub>	–	–	ns	Minimum possible width of Overflow, Underflow, and CC (Counter equals Compare value) trigger outputs
SID.TCPWM.5A	TCRES	Resolution of Counter	1/F <sub>c</sub>	–	–	ns	Minimum time between successive counts
SID.TCPWM.5B	PWMRES	PWM Resolution	1/F <sub>c</sub>	–	–	ns	Minimum pulse width of PWM Output
SID.TCPWM.5C	QRES	Quadrature inputs resolution	1/F <sub>c</sub>	–	–	ns	Minimum pulse width between Quadrature phase inputs.

<sup>2</sup>C

**Table 16. Fixed I<sup>2</sup>C DC Specifications**

(Guaranteed by Characterization)

Spec ID#	Parameter	Description	Min	Typ	Max	Units	Details/Conditions
SID149	I <sub>I2C1</sub>	Block current consumption at 100 kHz	–	–	50	μA	
SID150	I <sub>I2C2</sub>	Block current consumption at 400 kHz	–	–	135	μA	
SID151	I <sub>I2C3</sub>	Block current consumption at 1 Mbps	–	–	310	μA	
SID152	I <sub>I2C4</sub>	I <sup>2</sup> C enabled in Deep Sleep mode	–	–	1.4	μA	

**Table 17. Fixed I<sup>2</sup>C AC Specifications**

(Guaranteed by Characterization)

Spec ID#	Parameter	Description	Min	Typ	Max	Units	Details/Conditions
SID153	F <sub>I2C1</sub>	Bit rate	–	–	1	Mbps	

*LCD Direct Drive*
**Table 18. LCD Direct Drive DC Specifications**

(Guaranteed by Characterization)

Spec ID#	Parameter	Description	Min	Typ	Max	Units	Details/Conditions
SID154	I <sub>LCDLOW</sub>	Operating current in low power mode	–	5	–	μA	16 × 4 small segment disp. at 50 Hz
SID155	C <sub>LCDCAP</sub>	LCD capacitance per segment/common driver	–	500	5000	pF	Guaranteed by Design
SID156	LCD <sub>OFFSET</sub>	Long-term segment offset	–	20	–	mV	
SID157	I <sub>LCDOP1</sub>	PWM Mode current. 5-V bias. 24-MHz IMO	–	0.6	–	mA	32 × 4 segments. 50 Hz, 25 °C
SID158	I <sub>LCDOP2</sub>	PWM Mode current. 3.3-V bias. 24-MHz IMO.	–	0.5	–	mA	32 × 4 segments. 50 Hz, 25 °C

**Table 19. LCD Direct Drive AC Specifications**

(Guaranteed by Characterization)

Spec ID#	Parameter	Description	Min	Typ	Max	Units	Details/Conditions
SID159	F <sub>LCD</sub>	LCD frame rate	10	50	150	Hz	

**Table 20. Fixed UART DC Specifications**

(Guaranteed by Characterization)

Spec ID#	Parameter	Description	Min	Typ	Max	Units	Details/Conditions
SID160	I <sub>UART1</sub>	Block current consumption at 100 Kbits/sec	–	–	55	μA	
SID161	I <sub>UART2</sub>	Block current consumption at 1000 Kbits/sec	–	–	312	μA	

**Table 21. Fixed UART AC Specifications**

(Guaranteed by Characterization)

Spec ID#	Parameter	Description	Min	Typ	Max	Units	Details/Conditions
SID162	F <sub>UART</sub>	Bit rate	–	–	1	Mbps	

*SPI Specifications*
**Table 22. Fixed SPI DC Specifications**

(Guaranteed by Characterization)

Spec ID#	Parameter	Description	Min	Typ	Max	Units	Details/Conditions
SID163	I <sub>SPI1</sub>	Block current consumption at 1 Mbits/sec	–	–	360	μA	
SID164	I <sub>SPI2</sub>	Block current consumption at 4 Mbits/sec	–	–	560	μA	
SID165	I <sub>SPI3</sub>	Block current consumption at 8 Mbits/sec	–	–	600	μA	

**Table 23. Fixed SPI AC Specifications**

(Guaranteed by Characterization)

Spec ID#	Parameter	Description	Min	Typ	Max	Units	Details/Conditions
SID166	F <sub>SPI</sub>	SPI operating frequency (master; 6X oversampling)	–	–	8	MHz	

**Table 24. Fixed SPI Master mode AC Specifications**

(Guaranteed by Characterization)

Spec ID#	Parameter	Description	Min	Typ	Max	Units	Details/Conditions
SID167	T <sub>DMO</sub>	MOSI valid after Sclock driving edge	–	–	15	ns	
SID168	T <sub>DSI</sub>	MISO valid before Sclock capturing edge. Full clock, late MISO Sampling used	20	–	–	ns	
SID169	T <sub>HMO</sub>	Previous MOSI data hold time with respect to capturing edge at Slave	0	–	–	ns	

**Table 25. Fixed SPI Slave mode AC Specifications**

(Guaranteed by Characterization)

Spec ID#	Parameter	Description	Min	Typ	Max	Units	Details/Conditions
SID170	T <sub>DMI</sub>	MOSI valid before Sclock capturing edge	40	–	–	ns	
SID171	T <sub>DSO</sub>	MISO valid after Sclock driving edge	–	–	42 + 3 × (1/FCPU)	ns	
SID171A	T <sub>DSO_ext</sub>	MISO valid after Sclock driving edge in Ext. Clock mode	–	–	48	ns	
SID172	T <sub>HSO</sub>	Previous MISO data hold time	0	–	–	ns	
SID172A	T <sub>SSELSCK</sub>	SSEL Valid to first SCK Valid edge	100	–	–	ns	

## Memory

**Table 26. Flash DC Specifications**

Spec ID#	Parameter	Description	Min	Typ	Max	Units	Details/Conditions
SID173	V <sub>PE</sub>	Erase and program voltage	1.71	–	5.5	V	

**Table 27. Flash AC Specifications**

Spec ID#	Parameter	Description	Min	Typ	Max	Units	Details/Conditions
SID174	T <sub>ROWWRITE</sub>	Row (block) write time (erase and program)	–	–	20	ms	Row (block) = 128 bytes
SID175	T <sub>ROWERASE</sub>	Row erase time	–	–	13	ms	
SID176	T <sub>ROWPROGRAM</sub>	Row program time after erase	–	–	7	ms	
SID178	T <sub>BULKERASE</sub>	Bulk erase time (128 KB)	–	–	35	ms	
SID179	T <sub>SECTORERASE</sub>	Sector erase time (8 KB)	–	–	15	ms	
SID180	T <sub>DEVPROG</sub>	Total device program time	–	–	15	seconds	Guaranteed by characterization
SID181	F <sub>END</sub>	Flash endurance	100 K	–	–	cycles	Guaranteed by characterization
SID182	F <sub>RET</sub>	Flash retention. T <sub>A</sub> ≤ 55 °C, 100 K P/E cycles	20	–	–	years	Guaranteed by characterization
SID182A		Flash retention. T <sub>A</sub> ≤ 85 °C, 10 K P/E cycles	10	–	–	years	Guaranteed by characterization
SID182B	F <sub>RETQ</sub>	Flash retention. T <sub>A</sub> ≤ 105 °C, 10K P/E cycles, ≤ three years at T <sub>A</sub> ≥ 85 °C	10	20	–	years	Guaranteed by characterization.

**System Resources**
*Power-on-Reset (POR) with Brown Out*
**Table 28. Imprecise Power On Reset (PRES)**

Spec ID#	Parameter	Description	Min	Typ	Max	Units	Details/Conditions
SID185	V <sub>RISEIPOR</sub>	Rising trip voltage	0.80	–	1.45	V	Guaranteed by characterization
SID186	V <sub>FALLIPOR</sub>	Falling trip voltage	0.75	–	1.4	V	Guaranteed by characterization
SID187	V <sub>IPOHYST</sub>	Hysteresis	15	–	200	mV	Guaranteed by characterization

**Table 29. Precise Power On Reset (POR)**

Spec ID#	Parameter	Description	Min	Typ	Max	Units	Details/Conditions
SID190	V <sub>FALLPPOR</sub>	BOD trip voltage in active and sleep modes	1.64	–	–	V	Guaranteed by characterization
SID192	V <sub>FALLDPSLP</sub>	BOD trip voltage in Deep Sleep	1.4	–	–	V	Guaranteed by characterization

*Voltage Monitors*
**Table 30. Voltage Monitors DC Specifications**

Spec ID#	Parameter	Description	Min	Typ	Max	Units	Details/Conditions
SID195	V <sub>LVI1</sub>	LVI_A/D_SEL[3:0] = 0000b	1.71	1.75	1.79	V	
SID196	V <sub>LVI2</sub>	LVI_A/D_SEL[3:0] = 0001b	1.76	1.80	1.85	V	
SID197	V <sub>LVI3</sub>	LVI_A/D_SEL[3:0] = 0010b	1.85	1.90	1.95	V	
SID198	V <sub>LVI4</sub>	LVI_A/D_SEL[3:0] = 0011b	1.95	2.00	2.05	V	
SID199	V <sub>LVI5</sub>	LVI_A/D_SEL[3:0] = 0100b	2.05	2.10	2.15	V	
SID200	V <sub>LVI6</sub>	LVI_A/D_SEL[3:0] = 0101b	2.15	2.20	2.26	V	
SID201	V <sub>LVI7</sub>	LVI_A/D_SEL[3:0] = 0110b	2.24	2.30	2.36	V	
SID202	V <sub>LVI8</sub>	LVI_A/D_SEL[3:0] = 0111b	2.34	2.40	2.46	V	
SID203	V <sub>LVI9</sub>	LVI_A/D_SEL[3:0] = 1000b	2.44	2.50	2.56	V	
SID204	V <sub>LVI10</sub>	LVI_A/D_SEL[3:0] = 1001b	2.54	2.60	2.67	V	
SID205	V <sub>LVI11</sub>	LVI_A/D_SEL[3:0] = 1010b	2.63	2.70	2.77	V	
SID206	V <sub>LVI12</sub>	LVI_A/D_SEL[3:0] = 1011b	2.73	2.80	2.87	V	
SID207	V <sub>LVI13</sub>	LVI_A/D_SEL[3:0] = 1100b	2.83	2.90	2.97	V	
SID208	V <sub>LVI14</sub>	LVI_A/D_SEL[3:0] = 1101b	2.93	3.00	3.08	V	
SID209	V <sub>LVI15</sub>	LVI_A/D_SEL[3:0] = 1110b	3.12	3.20	3.28	V	
SID210	V <sub>LVI16</sub>	LVI_A/D_SEL[3:0] = 1111b	4.39	4.50	4.61	V	
SID211	LVI_IDD	Block current	–	–	100	μA	Guaranteed by characterization

**Table 31. Voltage Monitors AC Specifications**

Spec ID#	Parameter	Description	Min	Typ	Max	Units	Details/Conditions
SID212	T <sub>MONTRIP</sub>	Voltage monitor trip time	–	–	1	μs	Guaranteed by characterization

*SWD Interface*
**Table 32. SWD Interface Specifications**

Spec ID#	Parameter	Description	Min	Typ	Max	Units	Details/Conditions
SID213	F_SWCLK1	$3.3\text{ V} \leq V_{DD} \leq 5.5\text{ V}$	–	–	14	MHz	SWDCLK $\leq$ 1/3 CPU clock frequency
SID214	F_SWCLK2	$1.71\text{ V} \leq V_{DD} \leq 3.3\text{ V}$	–	–	7	MHz	SWDCLK $\leq$ 1/3 CPU clock frequency
SID215	T_SWDI_SETUP	$T = 1/f\text{ SWDCLK}$	0.25*T	–	–	ns	Guaranteed by characterization
SID216	T_SWDI_HOLD	$T = 1/f\text{ SWDCLK}$	0.25*T	–	–	ns	Guaranteed by characterization
SID217	T_SWDO_VALID	$T = 1/f\text{ SWDCLK}$	–	–	0.5*T	ns	Guaranteed by characterization
SID217A	T_SWDO_HOLD	$T = 1/f\text{ SWDCLK}$	1	–	–	ns	Guaranteed by characterization

*Internal Main Oscillator*
**Table 33. IMO DC Specifications**

(Guaranteed by Design)

Spec ID#	Parameter	Description	Min	Typ	Max	Units	Details/Conditions
SID218	I <sub>IMO1</sub>	IMO operating current at 48 MHz	–	–	1000	μA	
SID219	I <sub>IMO2</sub>	IMO operating current at 24 MHz	–	–	325	μA	
SID220	I <sub>IMO3</sub>	IMO operating current at 12 MHz	–	–	225	μA	
SID221	I <sub>IMO4</sub>	IMO operating current at 6 MHz	–	–	180	μA	
SID222	I <sub>IMO5</sub>	IMO operating current at 3 MHz	–	–	150	μA	

**Table 34. IMO AC Specifications**

Spec ID#	Parameter	Description	Min	Typ	Max	Units	Details/Conditions
SID223	F <sub>IMOTOL1</sub>	Frequency variation from 3 to 48 MHz	–	–	±2	%	±3% if T <sub>A</sub> > 85 °C and IMO frequency < 24 MHz
SID226	T <sub>STARTIMO</sub>	IMO startup time	–	–	12	μs	
SID227	T <sub>JITRMSIMO1</sub>	RMS Jitter at 3 MHz	–	156	–	ps	
SID228	T <sub>JITRMSIMO2</sub>	RMS Jitter at 24 MHz	–	145	–	ps	
SID229	T <sub>JITRMSIMO3</sub>	RMS Jitter at 48 MHz	–	139	–	ps	

*Internal Low-Speed Oscillator*
**Table 35. ILO DC Specifications**

(Guaranteed by Design)

Spec ID#	Parameter	Description	Min	Typ	Max	Units	Details/Conditions
SID231	I <sub>ILO1</sub>	ILO operating current at 32 kHz	–	0.3	1.05	μA	Guaranteed by Characterization
SID233	I <sub>ILOLEAK</sub>	ILO leakage current	–	2	15	nA	Guaranteed by Design

**Table 36. ILO AC Specifications**

Spec ID#	Parameter	Description	Min	Typ	Max	Units	Details/Conditions
SID234	T <sub>STARTILO1</sub>	ILO startup time	–	–	2	ms	Guaranteed by characterization
SID236	T <sub>ILODUTY</sub>	ILO duty cycle	40	50	60	%	Guaranteed by characterization
SID237	F <sub>ILOTRIM1</sub>	32 kHz trimmed frequency	15	32	50	kHz	Max ILO frequency is 70 kHz if T <sub>A</sub> > 85 °C

**Table 37. External Clock Specifications**

Spec ID#	Parameter	Description	Min	Typ	Max	Units	Details/Conditions
SID305	ExtClkFreq	External Clock input Frequency	0	–	48	MHz	Guaranteed by characterization
SID306	ExtClkDuty	Duty cycle; Measured at V <sub>DD/2</sub>	45	–	55	%	Guaranteed by characterization

**Table 38. Watch Crystal Oscillator (WCO) Specifications**

Spec ID#	Parameter	Description	Min	Typ	Max	Units	Details / Conditions
<b>IMO WCO-PLL calibrated mode</b>							
SID330	IMO <sub>WCO1</sub>	Frequency variation with IMO set to 3 MHz	–0.6	–	0.6	%	Does not include WCO tolerance
SID331	IMO <sub>WCO2</sub>	Frequency variation with IMO set to 5 MHz	–0.4	–	0.4	%	Does not include WCO tolerance
SID332	IMO <sub>WCO3</sub>	Frequency variation with IMO set to 7 MHz or 9 MHz	–0.3	–	0.3	%	Does not include WCO tolerance
SID333	IMO <sub>WCO4</sub>	All other IMO frequency settings	–0.2	–	0.2	%	Does not include WCO tolerance
<b>WCO Specifications</b>							
SID398	F <sub>WCO</sub>	Crystal frequency	–	32.768		kHz	
SID399	F <sub>TOL</sub>	Frequency tolerance	–	50	250	ppm	With 20-ppm crystal.
SID400	ESR	Equivalent series resistance	–	50	–	kΩ	
SID401	PD	Drive level	–	–	1	μW	
SID402	T <sub>START</sub>	Startup time	–	–	500	ms	
SID403	C <sub>L</sub>	Crystal load capacitance	6	–	12.5	pF	
SID404	C <sub>0</sub>	Crystal shunt capacitance	–	1.35	–	pF	
SID405	I <sub>WCO1</sub>	Operating current (high power mode)	–	–	8	uA	

**Table 39. Block Specs**

Spec ID#	Parameter	Description	Min	Typ	Max	Units	Details/Conditions
SID257	T <sub>WS24</sub> *	Number of wait states at 24 MHz	1	–	–		CPU execution from Flash
SID260	V <sub>REFSAR</sub>	Trimmed internal reference to SAR	–1	–	+1	%	Percentage of V <sub>bg</sub> (1.024 V). Guaranteed by characterization
SID261	F <sub>SARINTREF</sub>	SAR operating speed without external reference bypass	–	–	100	ksps	12-bit resolution. Guaranteed by characterization
SID262	T <sub>CLKSWITCH</sub>	Clock switching from clk1 to clk2 in clk1 periods	3	–	4	Periods	Guaranteed by design

\* T<sub>WS24</sub> is guaranteed by design

## Ordering Information

The SHM35920-M family part numbers and features are listed in the following table.

Part Number	MCU Core								Digital			I/O		Package
	Max CPU Speed (MHz)	Flash (KB)	SRAM (KB)	ADC	IDAC	Opamp	LP Comparator	CSD	Direct LCD Drive	UDBs	TCPWM Blocks	SCB Blocks	GPIO	
CYSHM35924I-M068LTI	24	64	8	806 ksp/s	1× 7-bit 1× 8-bit	2	2	–	✓	–	8	4	55	68-QFN
CYSHM35925I-M068LTI	24	128	16	806 ksp/s	1× 7-bit 1× 8-bit	2	2	–	✓	–	8	4	55	68-QFN

The nomenclature used in the preceding table is based on the following part numbering convention:

Field	Description	Values	Meaning
CY	Company ID	CY	Cypress
SHM	Marketing Code	SHM	System Hardware Manager
3	Architecture	3	Third Generation
A	Product Family	5	Full Programmable
B	Analog Channels	9	Programmable (Limited by IO)
C	Signal Processing Engine: Processing Core	2	ARM Cortex M0
D	Signal Processing Engine: Flash Size	2	16 KB
		3	32 KB
		4	64 KB
		5	128 KB
		6	256 KB
E	Product Type	I	Intelligent Analog
		P	Programmable Analog
F	Device Class	S	SHM 35000 S-Class
		M	SHM 35000 M-Class
		L	SHM 35000 L-Class
GHI	Package Pins	000-999	Number of Pins on Package
JK	Package Type	BZ	BGA
		AX	TQFP
		LT	QFN
		PV	SSOP
		FN	CSP
L	Temperature Grade	I	Industrial
M	Tape and Reel	T	Tape and Reel N/A for other packages

## Packaging

The description of the SHM35920-M package dimensions follows.

**Table 40. Packaging Dimensions**

Spec ID#	Package	Description	Package Dwg #
PKG_1	68-pin QFN	68 QFN, 8 mm x 8 mm x 1.0 mm height	001-09618

**Table 41. Package Characteristics**

Parameter	Description	Conditions	Min	Typ	Max	Units
T <sub>A</sub>	Operating ambient temperature		-40	25	85	°C
T <sub>J</sub>	Operating junction temperature		-40	-	100	°C
T <sub>JA</sub>	Package θ <sub>JA</sub> (68-pin QFN)		-	16.8	-	°C/Watt
T <sub>JC</sub>	Package θ <sub>JC</sub> (68-pin QFN)		-	2.9	-	°C/Watt

**Table 42. Solder Reflow Peak Temperature**

Package	Maximum Peak Temperature	Maximum Time at Peak Temperature
All packages	260 °C	30 seconds

**Table 43. Package Moisture Sensitivity Level (MSL), IPC/JEDEC J-STD-2**

Package	MSL
All packages	MSL 3

**Figure 4. 68-Pin 8 x 8 x 1.0 mm QFN Package Outline**

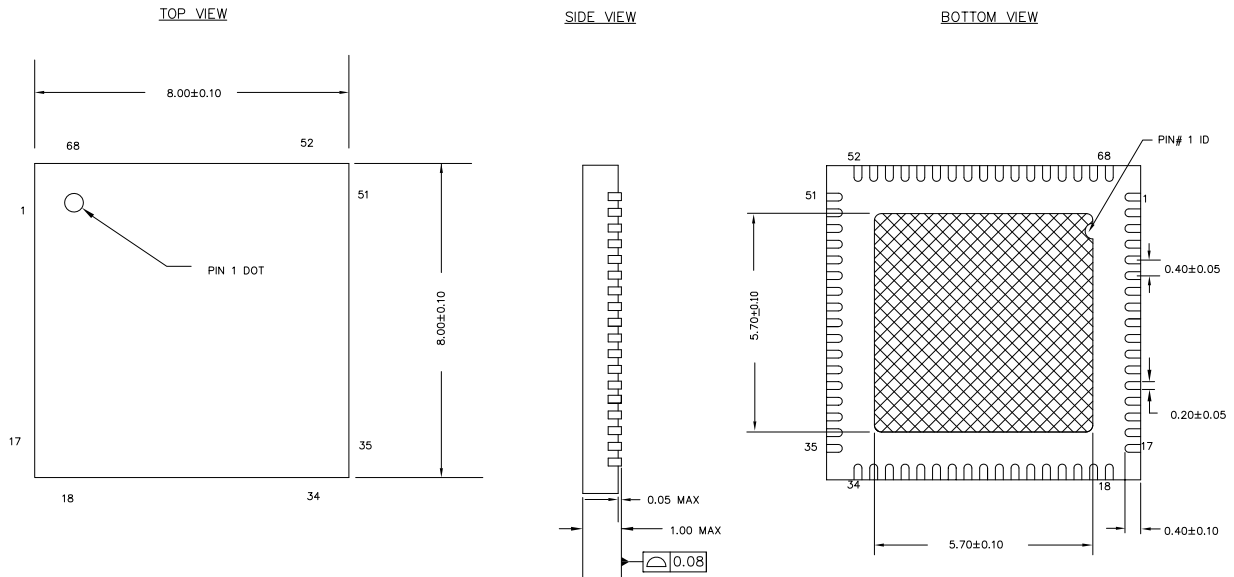

**NOTES:**

1. HATCH AREA IS SOLDERABLE EXPOSED METAL.
2. REFERENCE JEDEC#: MO-220
3. PACKAGE WEIGHT: 17 ± 2mg
4. ALL DIMENSIONS ARE IN MILLIMETERS

001-09618 \*E

## Acronyms

**Table 44. Acronyms Used in this Document**

Acronym	Description
abus	analog local bus
ADC	analog-to-digital converter
AG	analog global
AHB	AMBA (advanced microcontroller bus architecture) high-performance bus, an ARM data transfer bus
ALU	arithmetic logic unit
AMUXBUS	analog multiplexer bus
API	application programming interface
APSR	application program status register
ARM®	advanced RISC machine, a CPU architecture
ATM	automatic thump mode
BW	bandwidth
CAN	Controller Area Network, a communications protocol
CMRR	common-mode rejection ratio
CPU	central processing unit
CRC	cyclic redundancy check, an error-checking protocol
DAC	digital-to-analog converter, see also IDAC, VDAC
DFB	digital filter block
DIO	digital input/output, GPIO with only digital capabilities, no analog. See GPIO.
DMIPS	Dhrystone million instructions per second
DMA	direct memory access, see also TD
DNL	differential nonlinearity, see also INL
DNU	do not use
DR	port write data registers
DSI	digital system interconnect
DWT	data watchpoint and trace
ECC	error correcting code
ECO	external crystal oscillator
EEPROM	electrically erasable programmable read-only memory
EMI	electromagnetic interference
EMIF	external memory interface
EOC	end of conversion
EOF	end of frame
EPSR	execution program status register
ESD	electrostatic discharge

**Table 44. Acronyms Used in this Document (continued)**

Acronym	Description
ETM	embedded trace macrocell
FIR	finite impulse response, see also IIR
FPB	flash patch and breakpoint
FS	full-speed
GPIO	general-purpose input/output, applies to a PSoC pin
HVI	high-voltage interrupt, see also LVI, LVD
IC	integrated circuit
IDAC	current DAC, see also DAC, VDAC
IDE	integrated development environment
I <sup>2</sup> C, or IIC	Inter-Integrated Circuit, a communications protocol
IIR	infinite impulse response, see also FIR
ILO	internal low-speed oscillator, see also IMO
IMO	internal main oscillator, see also ILO
INL	integral nonlinearity, see also DNL
I/O	input/output, see also GPIO, DIO, SIO, USBIO
IPOR	initial power-on reset
IPSR	interrupt program status register
IRQ	interrupt request
ITM	instrumentation trace macrocell
LCD	liquid crystal display
LIN	Local Interconnect Network, a communications protocol.
LR	link register
LUT	lookup table
LVD	low-voltage detect, see also LVI
LVI	low-voltage interrupt, see also HVI
LVTTTL	low-voltage transistor-transistor logic
MAC	multiply-accumulate
MCU	microcontroller unit
MISO	master-in slave-out
NC	no connect
NMI	nonmaskable interrupt
NRZ	non-return-to-zero
NVIC	nested vectored interrupt controller
NVL	nonvolatile latch, see also WOL
opamp	operational amplifier
PAL	programmable array logic, see also PLD
PC	program counter
PCB	printed circuit board

**Table 44. Acronyms Used in this Document** *(continued)*

Acronym	Description
PGA	programmable gain amplifier
PHUB	peripheral hub
PHY	physical layer
PICU	port interrupt control unit
PLA	programmable logic array
PLD	programmable logic device, see also PAL
PLL	phase-locked loop
PMDD	package material declaration data sheet
POR	power-on reset
PRES	precise power-on reset
PRS	pseudo random sequence
PS	port read data register
PSoC®	Programmable System-on-Chip™
PSRR	power supply rejection ratio
PWM	pulse-width modulator
RAM	random-access memory
RISC	reduced-instruction-set computing
RMS	root-mean-square
RTC	real-time clock
RTL	register transfer language
RTR	remote transmission request
RX	receive
SAR	successive approximation register
SC/CT	switched capacitor/continuous time
SCL	I <sup>2</sup> C serial clock
SDA	I <sup>2</sup> C serial data
S/H	sample and hold
SINAD	signal to noise and distortion ratio
SIO	special input/output, GPIO with advanced features. See GPIO.
SOC	start of conversion
SOF	start of frame
SPI	Serial Peripheral Interface, a communications protocol
SR	slew rate
SRAM	static random access memory
SRES	software reset
SWD	serial wire debug, a test protocol
SWV	single-wire viewer
TD	transaction descriptor, see also DMA

**Table 44. Acronyms Used in this Document** *(continued)*

Acronym	Description
THD	total harmonic distortion
TIA	transimpedance amplifier
TRM	technical reference manual
TTL	transistor-transistor logic
TX	transmit
UART	Universal Asynchronous Transmitter Receiver, a communications protocol
UDB	universal digital block
USB	Universal Serial Bus
USBIO	USB input/output, PSoC pins used to connect to a USB port
VDAC	voltage DAC, see also DAC, IDAC
WDT	watchdog timer
WOL	write once latch, see also NVL
WRES	watchdog timer reset
XRES	external reset I/O pin
XTAL	crystal

## Document Conventions

### Units of Measure

**Table 45. Units of Measure**

Symbol	Unit of Measure
°C	degrees Celsius
dB	decibel
fF	femto farad
Hz	hertz
KB	1024 bytes
kbps	kilobits per second
Khr	kilohour
kHz	kilohertz
kΩ	kilo ohm
ksps	kilosamples per second
LSB	least significant bit
Mbps	megabits per second
MHz	megahertz
MΩ	mega-ohm
Msps	megasamples per second
μA	microampere
μF	microfarad
μH	microhenry
μs	microsecond
μV	microvolt
μW	microwatt
mA	milliampere
ms	millisecond
mV	millivolt
nA	nanoampere
ns	nanosecond
nV	nanovolt
Ω	ohm
pF	picofarad
ppm	parts per million
ps	picosecond
s	second
sps	samples per second
sqrtHz	square root of hertz
V	volt

## Revision History

Description Title: SHM 35-Series: SHM35920-M Family Datasheet System Hardware Manager (SHM) Document Number: 002-13261				
Revision	ECN	Orig. of Change	Submission Date	Description of Change
**	5324831	WKA/RLRM	06/28/2016	New datasheet.
*A	5378004	RLRM	07/28/2016	Corrected the MPNs in <a href="#">Ordering Information</a> .
*B	5981775	AESATP12	12/04/2017	Updated logo and copyright.

## Sales, Solutions, and Legal Information

### Worldwide Sales and Design Support

Cypress maintains a worldwide network of offices, solution centers, manufacturer's representatives, and distributors. To find the office closest to you, visit us at [Cypress Locations](#).

### Products

ARM <sup>®</sup> Cortex <sup>®</sup> Microcontrollers	<a href="http://cypress.com/arm">cypress.com/arm</a>
Automotive	<a href="http://cypress.com/automotive">cypress.com/automotive</a>
Clocks & Buffers	<a href="http://cypress.com/clocks">cypress.com/clocks</a>
Interface	<a href="http://cypress.com/interface">cypress.com/interface</a>
Internet of Things	<a href="http://cypress.com/iot">cypress.com/iot</a>
Memory	<a href="http://cypress.com/memory">cypress.com/memory</a>
Microcontrollers	<a href="http://cypress.com/mcu">cypress.com/mcu</a>
PSoC	<a href="http://cypress.com/psoc">cypress.com/psoc</a>
Power Management ICs	<a href="http://cypress.com/pmic">cypress.com/pmic</a>
Touch Sensing	<a href="http://cypress.com/touch">cypress.com/touch</a>
USB Controllers	<a href="http://cypress.com/usb">cypress.com/usb</a>
Wireless Connectivity	<a href="http://cypress.com/wireless">cypress.com/wireless</a>

### PSoC<sup>®</sup> Solutions

[PSoC 1](#) | [PSoC 3](#) | [PSoC 4](#) | [PSoC 5LP](#) | [PSoC 6](#)

### Cypress Developer Community

[Forums](#) | [WICED IOT Forums](#) | [Projects](#) | [Video](#) | [Blogs](#) | [Training](#) | [Components](#)

### Technical Support

[cypress.com/support](http://cypress.com/support)

© Cypress Semiconductor Corporation, 2016-2017. This document is the property of Cypress Semiconductor Corporation and its subsidiaries, including Spansion LLC ("Cypress"). This document, including any software or firmware included or referenced in this document ("Software"), is owned by Cypress under the intellectual property laws and treaties of the United States and other countries worldwide. Cypress reserves all rights under such laws and treaties and does not, except as specifically stated in this paragraph, grant any license under its patents, copyrights, trademarks, or other intellectual property rights. If the Software is not accompanied by a license agreement and you do not otherwise have a written agreement with Cypress governing the use of the Software, then Cypress hereby grants you a personal, non-exclusive, nontransferable license (without the right to sublicense) (1) under its copyright rights in the Software (a) for Software provided in source code form, to modify and reproduce the Software solely for use with Cypress hardware products, only internally within your organization, and (b) to distribute the Software in binary code form externally to end users (either directly or indirectly through resellers and distributors), solely for use on Cypress hardware product units, and (2) under those claims of Cypress's patents that are infringed by the Software (as provided by Cypress, unmodified) to make, use, distribute, and import the Software solely for use with Cypress hardware products. Any other use, reproduction, modification, translation, or compilation of the Software is prohibited.

TO THE EXTENT PERMITTED BY APPLICABLE LAW, CYPRESS MAKES NO WARRANTY OF ANY KIND, EXPRESS OR IMPLIED, WITH REGARD TO THIS DOCUMENT OR ANY SOFTWARE OR ACCOMPANYING HARDWARE, INCLUDING, BUT NOT LIMITED TO, THE IMPLIED WARRANTIES OF MERCHANTABILITY AND FITNESS FOR A PARTICULAR PURPOSE. To the extent permitted by applicable law, Cypress reserves the right to make changes to this document without further notice. Cypress does not assume any liability arising out of the application or use of any product or circuit described in this document. Any information provided in this document, including any sample design information or programming code, is provided only for reference purposes. It is the responsibility of the user of this document to properly design, program, and test the functionality and safety of any application made of this information and any resulting product. Cypress products are not designed, intended, or authorized for use as critical components in systems designed or intended for the operation of weapons, weapons systems, nuclear installations, life-support devices or systems, other medical devices or systems (including resuscitation equipment and surgical implants), pollution control or hazardous substances management, or other uses where the failure of the device or system could cause personal injury, death, or property damage ("Unintended Uses"). A critical component is any component of a device or system whose failure to perform can be reasonably expected to cause the failure of the device or system, or to affect its safety or effectiveness. Cypress is not liable, in whole or in part, and you shall and hereby do release Cypress from any claim, damage, or other liability arising from or related to all Unintended Uses of Cypress products. You shall indemnify and hold Cypress harmless from and against all claims, costs, damages, and other liabilities, including claims for personal injury or death, arising from or related to any Unintended Uses of Cypress products.

Cypress, the Cypress logo, Spansion, the Spansion logo, and combinations thereof, WICED, PSoC, CapSense, EZ-USB, F-RAM, and Traveo are trademarks or registered trademarks of Cypress in the United States and other countries. For a more complete list of Cypress trademarks, visit [cypress.com](http://cypress.com). Other names and brands may be claimed as property of their respective owners.

## Looking for pricing, stock, or lifecycle information?

Click below to explore more details on WIN SOURCE:

 [View CYSHM35925I-M068LTI on WIN SOURCE](#)

 [Infineon Technologies](#) Information

## Optimize Your Supply Chain with WIN SOURCE Solutions

-  Global Sourcing Solution
-  Obsolete Management
-  Cost Control Management
-  Shortage Management
-  Alternative Solution
-  Excess Inventory Management