



THE DATASHEET OF CY3236A-PIRMOTION





CY3236A

Pyroelectric Infrared (PIR) Motion Sensor Evaluation Kit Guide

Doc. # 001-68617 Rev. *A

Cypress Semiconductor
198 Champion Court
San Jose, CA 95134-1709
Phone (USA): 800.858.1810
Phone (Intl): 408.943.2600
<http://www.cypress.com>

Copyrights

© Cypress Semiconductor Corporation, 2011. The information contained herein is subject to change without notice. Cypress Semiconductor Corporation assumes no responsibility for the use of any circuitry other than circuitry embodied in a Cypress product. Nor does it convey or imply any license under patent or other rights. Cypress products are not warranted nor intended to be used for medical, life support, life saving, critical control or safety applications, unless pursuant to an express written agreement with Cypress. Furthermore, Cypress does not authorize its products for use as critical components in life-support systems where a malfunction or failure may reasonably be expected to result in significant injury to the user. The inclusion of Cypress products in life-support systems application implies that the manufacturer assumes all risk of such use and in doing so indemnifies Cypress against all charges.

Any Source Code (software and/or firmware) is owned by Cypress Semiconductor Corporation (Cypress) and is protected by and subject to worldwide patent protection (United States and foreign), United States copyright laws and international treaty provisions. Cypress hereby grants to licensee a personal, non-exclusive, non-transferable license to copy, use, modify, create derivative works of, and compile the Cypress Source Code and derivative works for the sole purpose of creating custom software and or firmware in support of licensee product to be used only in conjunction with a Cypress integrated circuit as specified in the applicable agreement. Any reproduction, modification, translation, compilation, or representation of this Source Code except as specified above is prohibited without the express written permission of Cypress.

Disclaimer: CYPRESS MAKES NO WARRANTY OF ANY KIND, EXPRESS OR IMPLIED, WITH REGARD TO THIS MATERIAL, INCLUDING, BUT NOT LIMITED TO, THE IMPLIED WARRANTIES OF MERCHANTABILITY AND FITNESS FOR A PARTICULAR PURPOSE. Cypress reserves the right to make changes without further notice to the materials described herein. Cypress does not assume any liability arising out of the application or use of any product or circuit described herein. Cypress does not authorize its products for use as critical components in life-support systems where a malfunction or failure may reasonably be expected to result in significant injury to the user. The inclusion of Cypress' product in a life-support systems application implies that the manufacturer assumes all risk of such use and in doing so indemnifies Cypress against all charges.

Use may be limited by and subject to the applicable Cypress software license agreement.

PSoC Designer™ and Programmable System-on-Chip™ are trademarks and PSoC® is a registered trademark of Cypress Semiconductor Corp. All other trademarks or registered trademarks referenced herein are property of the respective corporations.

Flash Code Protection

Cypress products meet the specifications contained in their particular Cypress PSoC Data Sheets. Cypress believes that its family of PSoC products is one of the most secure families of its kind on the market today, regardless of how they are used. There may be methods, unknown to Cypress, that can breach the code protection features. Any of these methods, to our knowledge, would be dishonest and possibly illegal. Neither Cypress nor any other semiconductor manufacturer can guarantee the security of their code. Code protection does not mean that we are guaranteeing the product as "unbreakable."

Cypress is willing to work with the customer who is concerned about the integrity of their code. Code protection is constantly evolving. We at Cypress are committed to continuously improving the code protection features of our products.

Contents



1. Introduction	5
1.1 Kit Contents	5
1.2 Prerequisites	6
1.3 Reference Documents	6
1.4 Document Revision History	7
1.5 Documentation Conventions	7
2. Getting Started	9
2.1 Kit Installation	9
2.2 PSoC Designer	13
2.3 PSoC Programmer	14
3. Kit Operations	15
3.1 Introduction	15
3.2 Evaluating the PSoC Device.....	15
3.2.1 Programming Specifications and Connections.....	16
4. Hardware	19
4.1 System Block Diagram	19
4.2 Functional Description	21
5. Code Examples	27
5.1 Project Description.....	27
5.2 Device Configuration	27
5.2.1 Flowchart.....	29
5.3 Verify Output - PIR Sensing.....	30
5.4 Ambient Light Sensing.....	31
A. Appendix	33
A.1 PIR Motion Sensor Board Schematic	33
A.2 Board Images	34
A.3 Bill of Materials	34

1. Introduction



This wavelength kit demonstrates the use of Cypress's PSoC[®] device to control a pyroelectric Infrared (PIR) sensor. The human body radiates a certain wavelength of infrared light – about 10 μm at normal body temperature. The concept behind PIR sensing is to capture this radiated light, filter the analog signals, convert those signals to digital, and then use those digital signals to control hardware. In the PIR Motion Sensor Evaluation kit, the conversion of these infrared rays to digital signals controls a relay and some LEDs.

The CY3236A-PIRMOTION EVK includes all of the software, hardware, code examples, and documentation you need to implement all of these PIR sensing control functions in one flexible and powerful PSoC device, the CY8C27443. An application note, AN2414, "*Proximity Sensing Using PIR*" is available on the Cypress website at <http://www.cypress.com/?rID=2794>.

Chapter 2 of this document describes the installation and configuration of the kit software. Chapter 3 explains the programming of a PSoC 1 device with PSoC Programmer. Chapter 4 describes the hardware operation. Chapter 5 provides instructions on how to use the kit with the help of a code example. The Appendix provides the schematics, layout, and bill of materials (BOM) for the kit.

1.1 Kit Contents

The PIR Motion Sensor Evaluation Kit includes the following:

- PIR sensor evaluation board
- 12-V power adapter
- CY8C27443-24PVXI sample silicon
- Quick start guide
- CY3236A-PIRMOTION kit DVD
 - PSoC Designer installation file
 - PSoC Programmer installation file
 - Bridge Control Panel installation file (packaged along with PSoC Programmer)
 - Code examples
 - Hardware files
 - Kit guide
 - Quick start guide
 - Release notes

Inspect the contents of the kit. If any parts are missing, contact your nearest Cypress sales office for further assistance.

1.2 Prerequisites

The following are required for the programming of the kit:

- CY3217-MiniProg1 is a programming tool that can be used to program all PSoC1 devices. This kit can be purchase separately at <http://www.cypress.com/go/CY3217-Minipro1>.

1.3 Reference Documents

The following documents are included in the documentation folder (<drive>:\Documentation\Datasheets):

- Datasheet – Glolab PIR325 Infrared Motion Detector
- Datasheet – Rohm PRM-075PT Phototransistor

Visit www.cypress.com for additional learning resources in the form of datasheets, technical reference manual, and application notes.

- For more information regarding PSoC Designer functionality and releases, go to: www.cypress.com/go/psocdesigner
- For more information regarding PSoC Programmer, supported hardware, and COM layer, go to: www.cypress.com/go/psocprogrammer
- For a list of PSoC Designer-related trainings, go to: <http://www.cypress.com/?rID=40543>
- Application note, AN2414 – Proximity Sensing Using PIR <http://www.cypress.com/?rID=279>
- Datasheet – CY8C27443 Cypress PSoC device <http://www.cypress.com/?rID=3324>

1.4 Document Revision History

Table 1-1. Revision History

Revision	PDF Creation Date	Origin of Change	Description of Change
**	04/18/2011	OWEN	Initial version of kit guide
*A	09/19/2011	RKPM	Added Kit Operations, Hardware, and Code Examples chapters. Added BOM and board images in Appendix. Content updates throughout the document. Changed title to "CY3236A Pyroelectric Infrared (PIR) Motion Sensor Evaluation Kit Guide".

1.5 Documentation Conventions

Table 1-2. Document Conventions for Guides

Convention	Usage
Courier New	Displays file locations, user entered text, and source code: C:\ ...cd\icc\
<i>Italics</i>	Displays file names and reference documentation: Read about the <i>sourcefile.hex</i> file in the <i>PSoC Designer User Guide</i> .
[Bracketed, Bold]	Displays keyboard commands in procedures: [Enter] or [Ctrl] [C]
File > Open	Represents menu paths: File > Open > New Project
Bold	Displays commands, menu paths, and icon names in procedures: Click the File icon and then click Open .
Times New Roman	Displays an equation: $2 + 2 = 4$
Text in gray boxes	Describes Cautions or unique functionality of the product.

2. Getting Started



This chapter describes how to install and configure the CY3236A-PIRMOTION kit.

2.1 Kit Installation

To install the kit software, follow these steps:

1. Insert the kit DVD into the DVD drive of your PC. The DVD is designed to auto-run and the kit installer startup screen appears.

Note You can also download the latest installer from <http://www.cypress.com/go/CY3236>.

Three different types of installers are available for download:

- CY3236A-PIRMOTION_ISO: This file (ISO image) is an archive file of the optical disc provided with the kit. You can use this to create an installer DVD or extract information using WinRar or similar tools.
- CY3236A-PIRMOTION_Single Package: This executable file installs the DVD contents, which includes PSoC Programmer, PSoC Designer, code examples, kit hardware files, and user documents.
- CY3236A-PIRMOTION_Single Package (without prerequisites): This executable file installs only the kit contents, which includes kit code examples, hardware files, and user documents.

2. Click 'Install CY3236A-PIRMOTION Kit' to start the installation.

Figure 2-1. Kit Installer Startup Screen



Note If auto-run does not execute, double-click *cyautorun.exe* file on the root directory of the DVD.

Figure 2-2. Root Directory of DVD

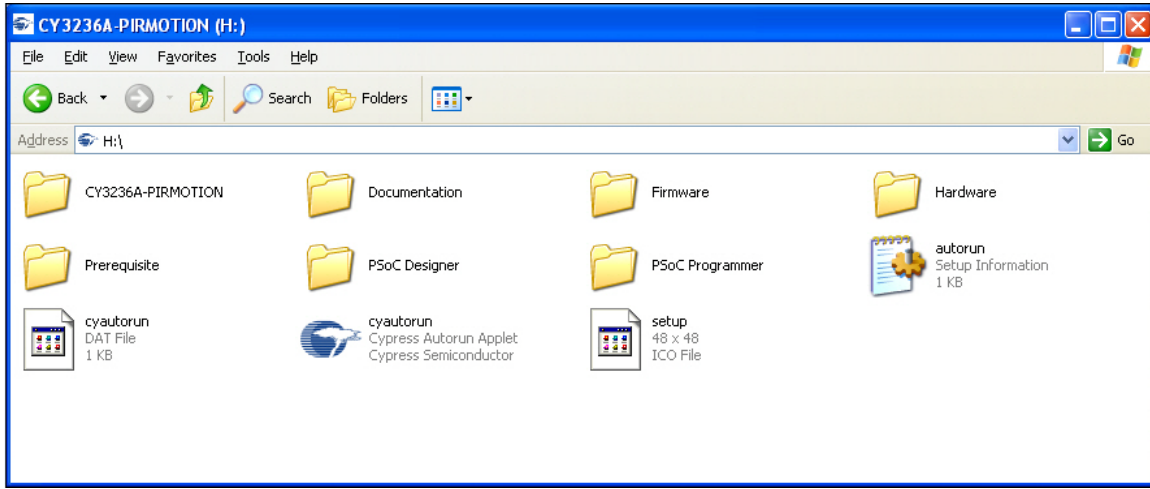

3. The InstallShield Wizard screen appears. On this screen, choose the folder location to install the setup files. You can change the location of the folder for the setup files using **Change** (see [Figure 2-3](#)).
4. Click Next to launch the kit installer.

Figure 2-3. InstallShield Wizard

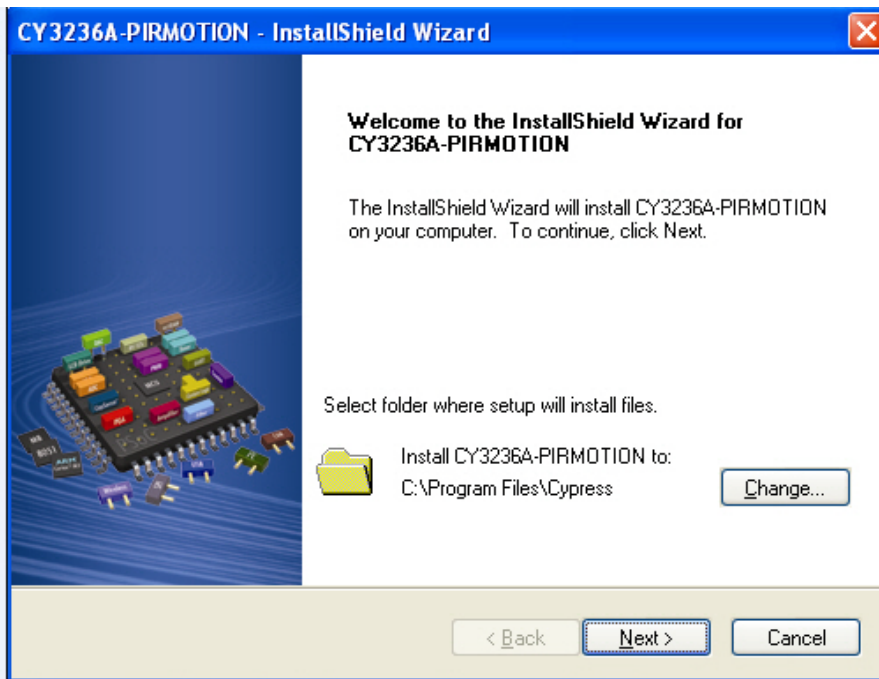

5. On the Product Installation Overview screen, select the installation type that best suits your requirement. The drop-down menu has three options - Typical, Custom, and Complete (see [Figure 2-4](#)).
6. Click Next to start the installation

Figure 2-4. Installation Type Options

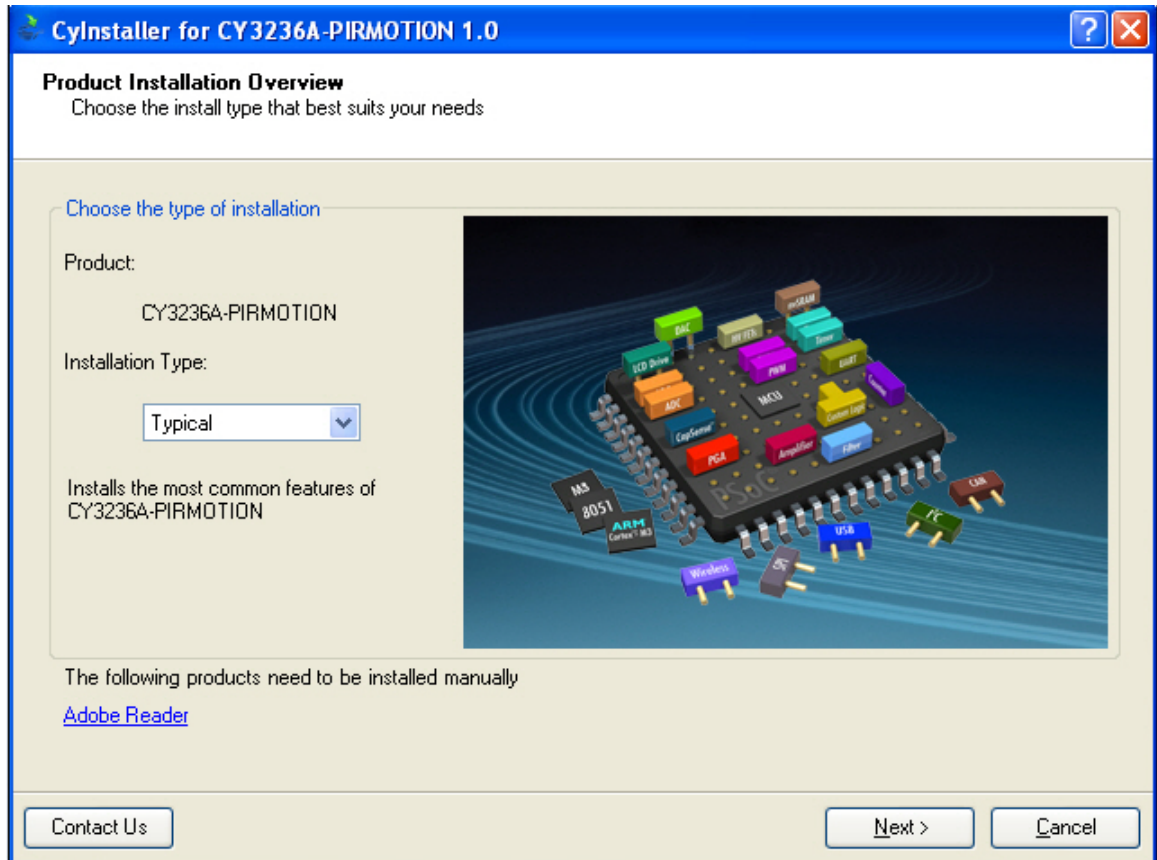

7. When the installation begins, a list of packages appears on the Installation Page. A green check mark appears adjacent to every package that is downloaded and installed (see Figure 2-5).
8. Wait until all the packages are downloaded and installed successfully.

Note Advanced users can go to [Code Examples on page 27](#).

2.2 PSoC Designer

1. Click **Start > All Programs > Cypress > PSoC Designer <version> > PSoC Designer <version>**.
2. Click **File > New Project**, to create a new project; click **File > Open Project** to work with an existing project.

Figure 2-7. PSoC Designer Interconnect View

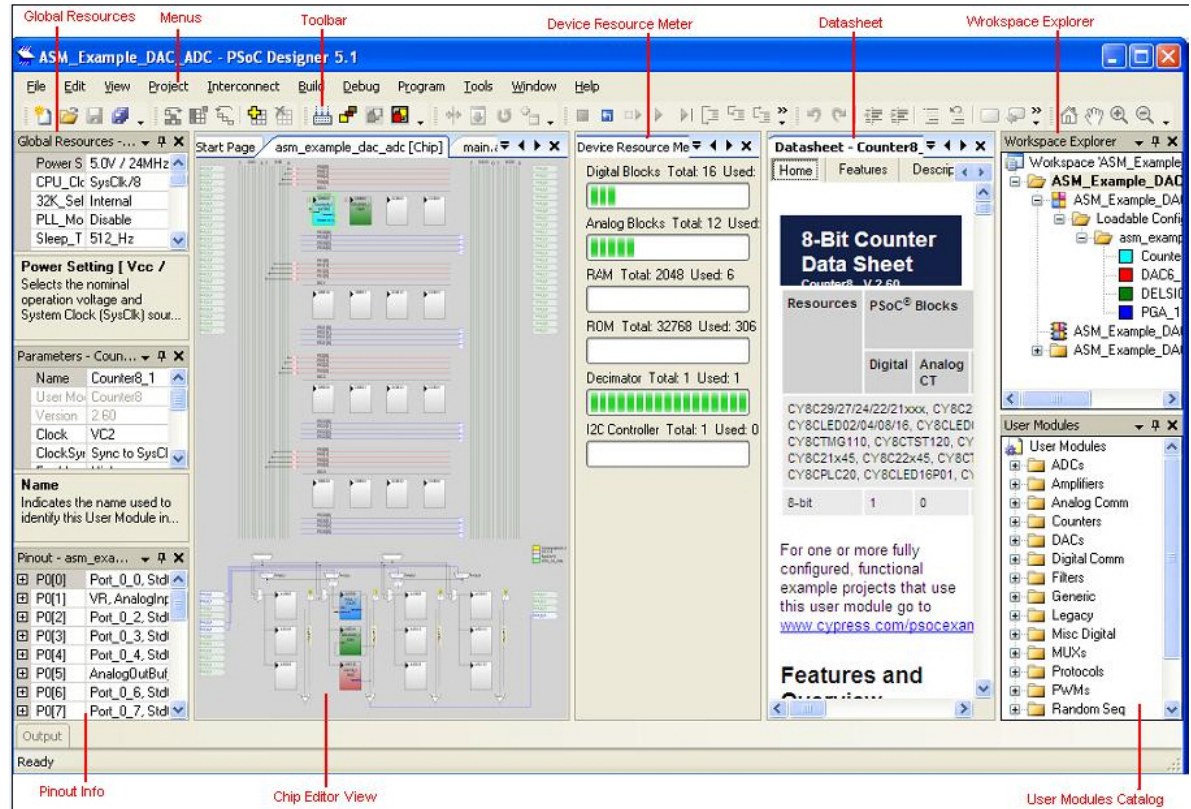

3. To experiment with the code examples, go to [Code Examples on page 27](#).

Note For more details on PSoC Designer, see the PSoC Designer IDE Guide located at: `<Install_Directory>\Cypress\PSoC Designer\<version>\Documentation`.

See [Reference Documents on page 6](#) for links to PSoC Designer training. The PSoC Designer quick start guide is available at: <http://www.cypress.com/?rID=47954>.

2.3 PSoC Programmer

1. Click **Start > All Programs > Cypress > PSoC Programmer <version> > PSoC Programmer <version>**.
2. Select the MiniProg from **Port Selection**.

Figure 2-8. PSoC Programmer Window

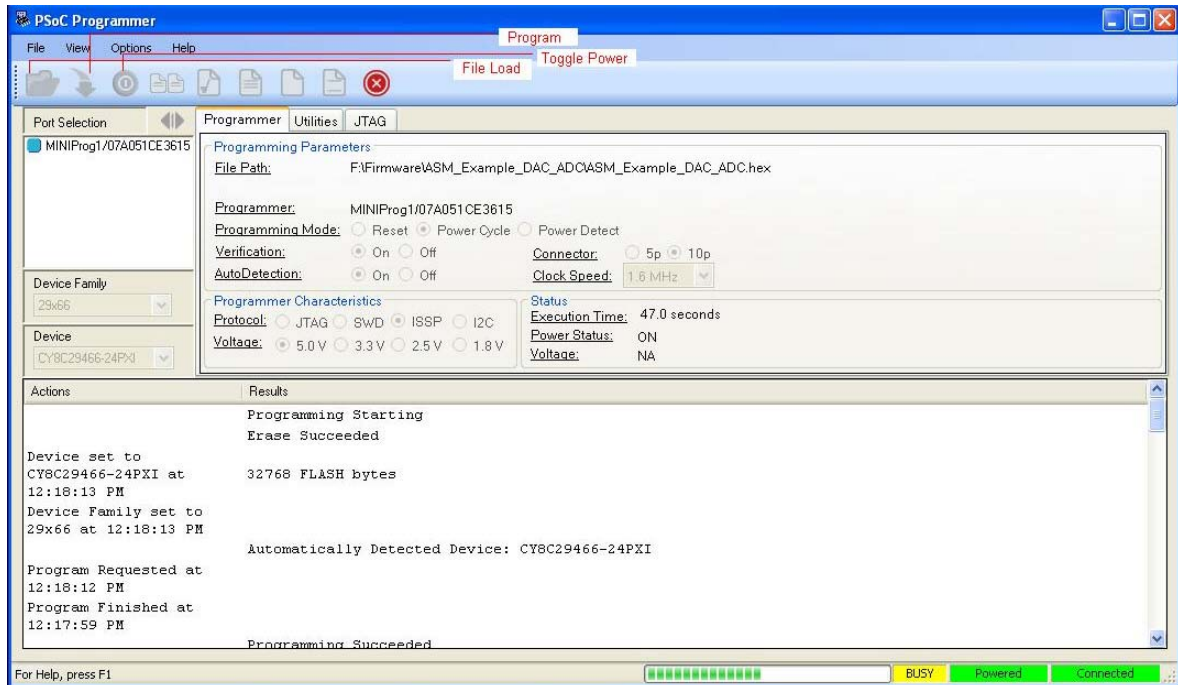

3. Click **File Load** to load the hex file.
4. Use the **Program** button to program the hex file on to the chip.
5. When programming is successful, **Programming Succeeded** appears in the Actions pane.
6. Close PSoC Programmer.

Note For more details on PSoC Programmer, see the user guide at the following location:
 <Install_Directory>\Program Files\Cypress\Programmer\<version>\Documents.

3. Kit Operations



3.1 Introduction

The CY3236A-PIRMOTION EVK allows you to evaluate Cypress's' PSoC (Programmable System-on-Chip™) device's ability to control a PIR sensor to implement motion sensing applications such as automatic lighting controls, automatic door openers, security systems, kiosk wakeup, and activating wireless cameras.

3.2 Evaluating the PSoC Device

To evaluate the default project programmed on the CY3236A-PIRMOTION board. Ensure that the jumper (shunt) is not connected on J4. Power the board using the 12-V adapter at the power jack, J1. Stimulate the infrared sensor by moving your hand over as shown in [Figure 3-1](#). The sensor status is indicated by D7. This LED (D7) turns on when hand is brought near the sensor. The Fresnel lens is used to direct infrared rays from various angles toward the PIR sensor. The AC terminal block can be used to connect an external hardware device.

Figure 3-1. Infrared Radiation Detected by Human Body

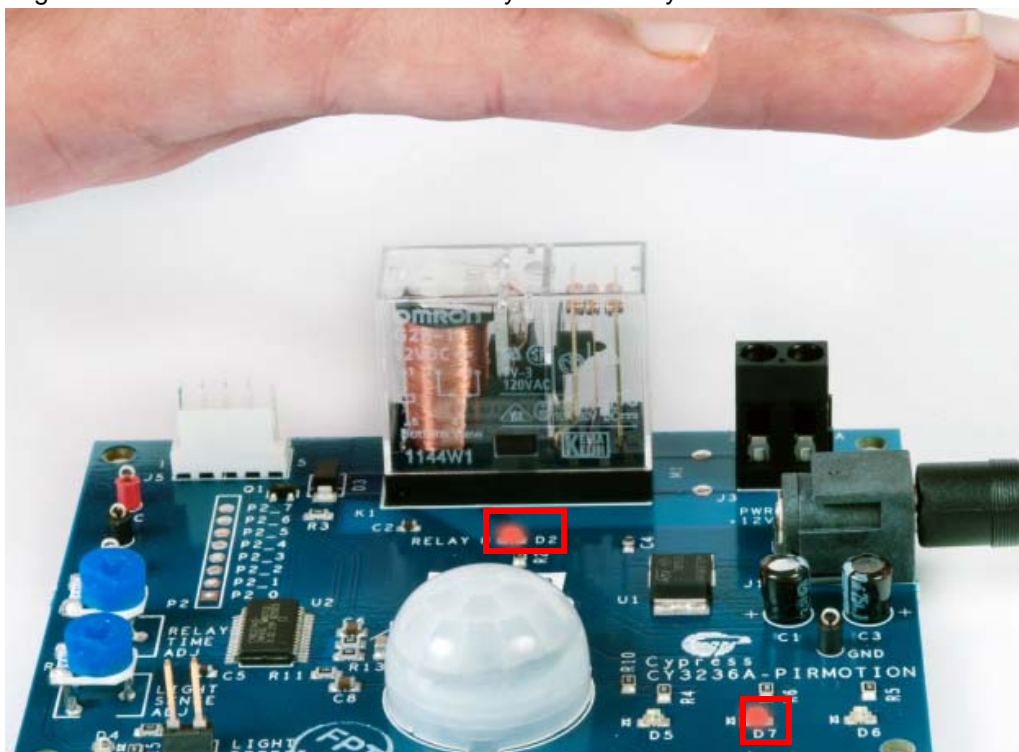

To adjust the length of time during which the relay is active, use the potentiometer, R7. Turn it counter-clockwise to increase the relay-on time and vice versa. Relay on is indicated by the LED, D2.

To enable the ambient light detector, shunt header J4. After enabling this feature, adjust the responsiveness of the board to light, using the potentiometer, R8.

If the PSoC on the board has been reprogrammed or erased, follow the steps in the section [3.2.1 Programming Specifications and Connections](#) to program the board with the hex file provided in the kit CD or installed directory

```
<Install_Directory>:\Cypress\CY3236A-PIRMOTION\<version>\Firmware\
```

3.2.1 Programming Specifications and Connections

When the MiniProg is connected, you can use PSoC Programmer to program the CY3236A-PIRMOTION Evaluation kit. Plug in the USB cable into the MiniProg before attaching it to the ISSP header on the board. When using MiniProg, the LEDs blink at a variable rate to track connection status. The green LED near the USB connector turns on after MiniProg is plugged into the computer and is configured by the operating system. If MiniProg cannot find the correct driver in the system, this LED does not turn on. After the device is configured, the LED stays on at about a 4-Hz blink rate. This changes during programming, when the blink duty cycle increases. The red LED (see [Figure 3-2](#)) at the bottom turns on when the MiniProg powers the part. The LED is off when power is provided by the target board.

Figure 3-2. Hardware Connections for Programming

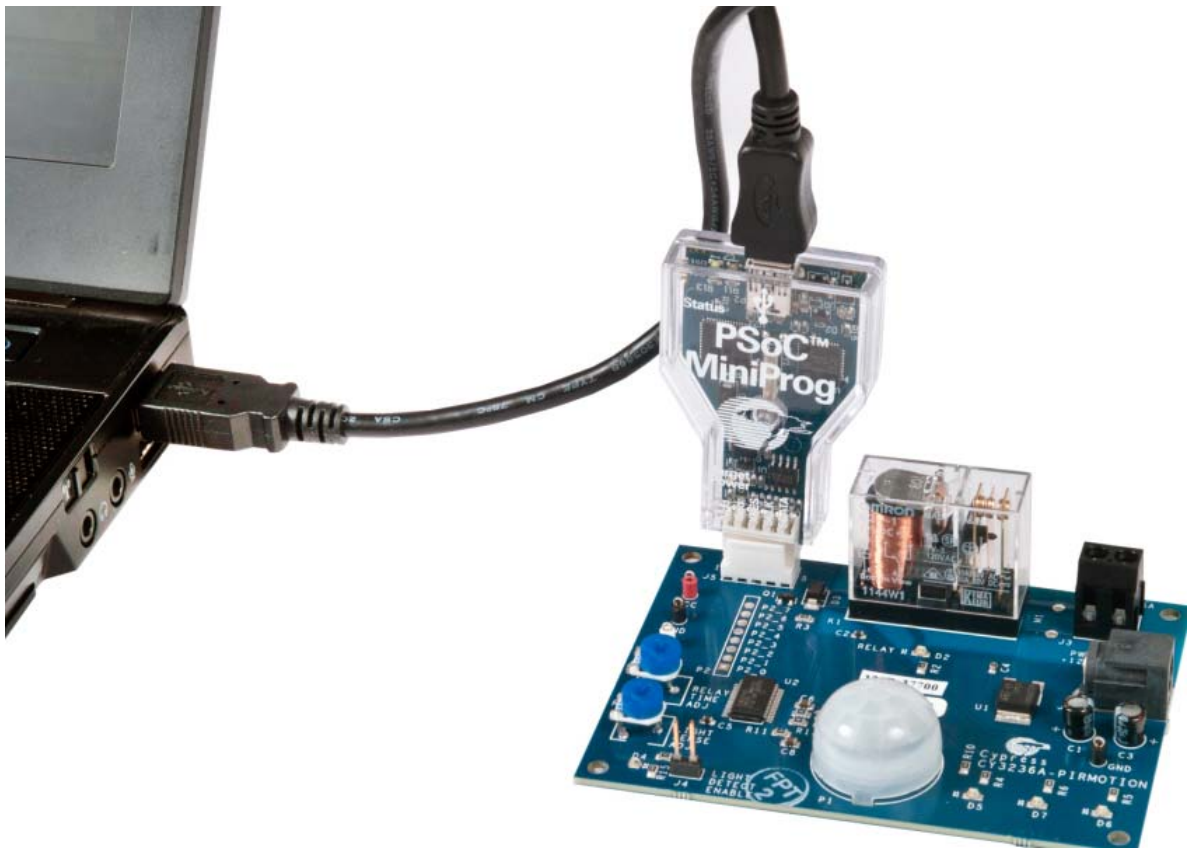
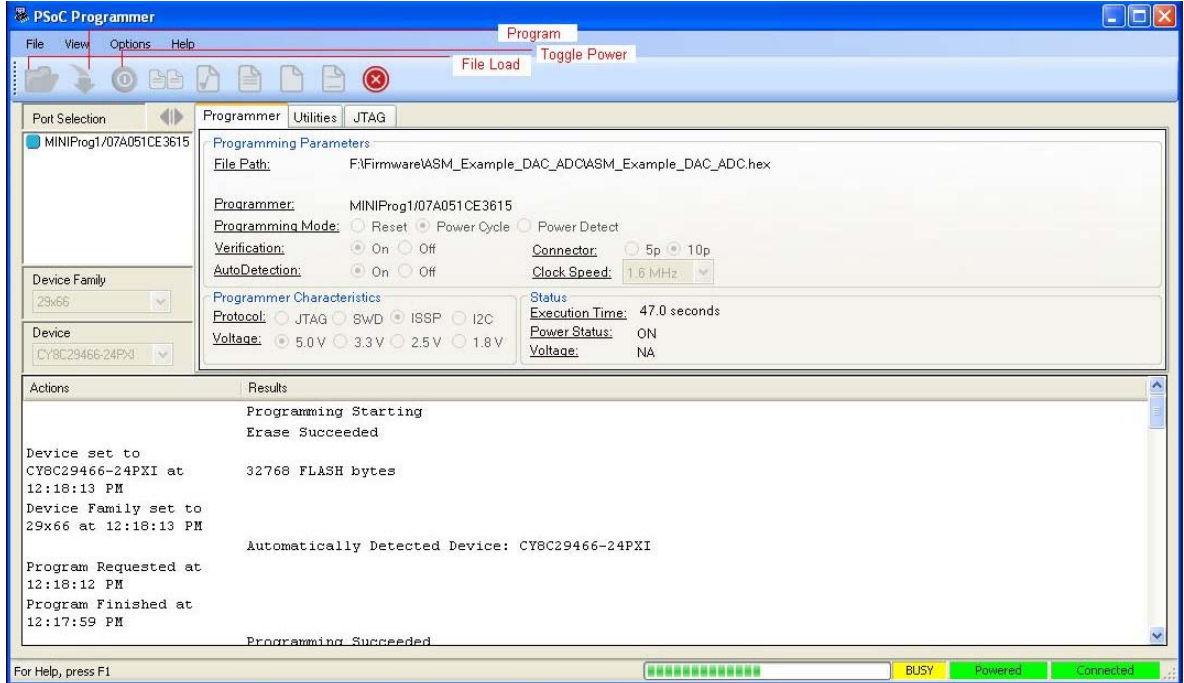

Figure 3-3. PSoC Programmer Window



Follow these steps to program using MiniProg1:

1. Connect the USB cable to the PC and MiniProg1 (Figure 3-2)
2. Plug in the MiniProg1 to the ISSP header on the CY3236A-PIRMOTION board
3. When USB is connected to the MiniProg1, LED (green) glows in the MiniProg1
4. Open PSoC Programmer
5. Click the **Load File** button and browse to the hex file location. Select the hex file and click **Open**
6. Click **Connect** or double click on the respective MiniProg under Port Selection to select or connect to MiniProg (in case not connected)
7. Click **Program** or press [F5] to initiate programming
8. The green LED on the MiniProg1 blinks to indicate the progress of programming
9. After successful programming, the red LED on MiniProg1 is powered off.

4. Hardware



This chapter provides an overview of the hardware, including power system, jumper setting, and programming interface. To start using the board, go to [Code Examples on page 27](#).

4.1 System Block Diagram

The CY3236A-PIRMOTION board has the following sections:

- PSoC CY88C27443 silicon
- Power supply and regulator
- Ambient light sensor
- PIR sensor
- ISSP programming header
- Test points
- Status LEDs
- Potentiometer to adjust relay time and light sensitivity
- Relay and AC terminal block
- GPIO expansion port

Figure 4-1. Hardware Block Diagram

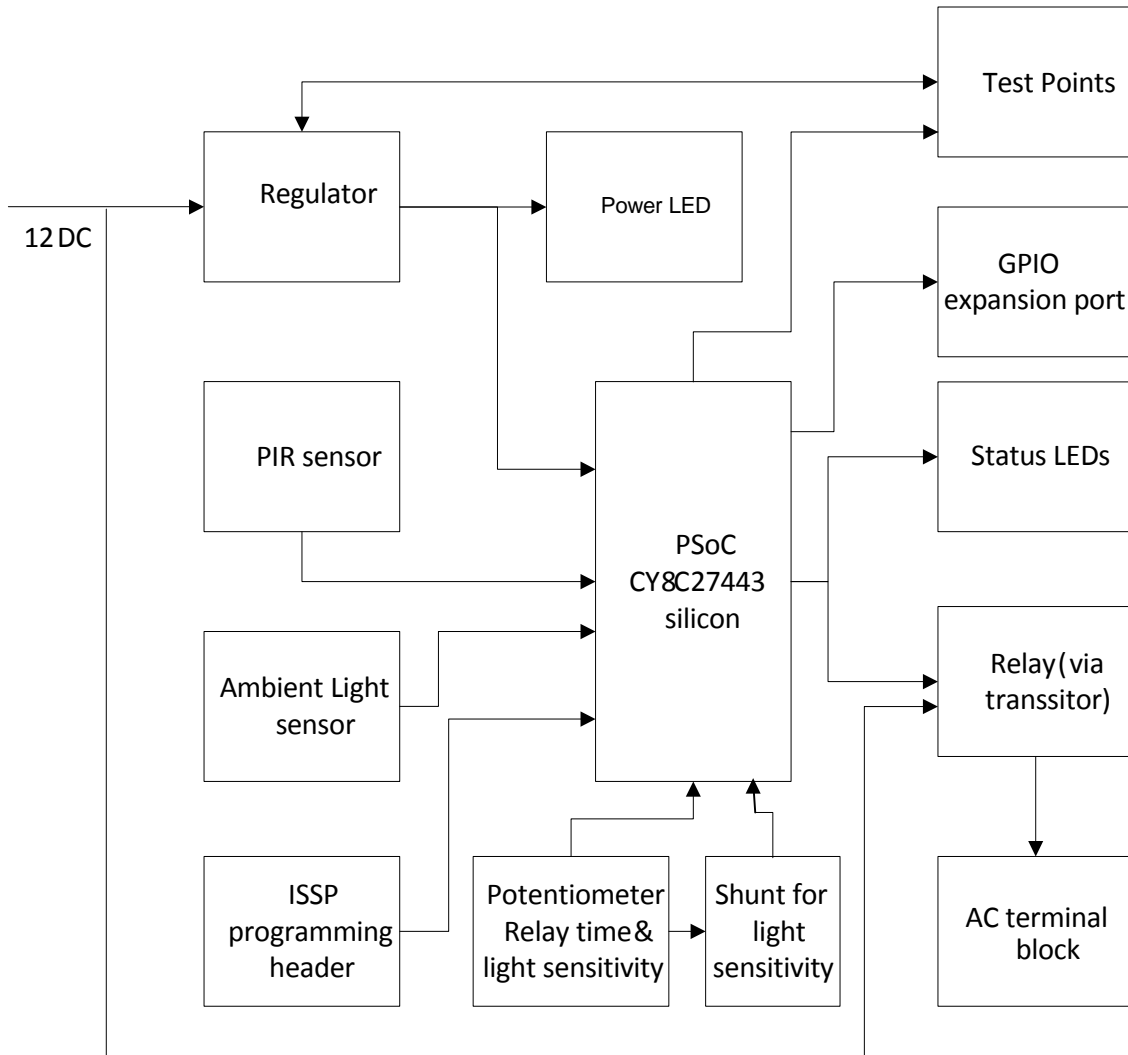
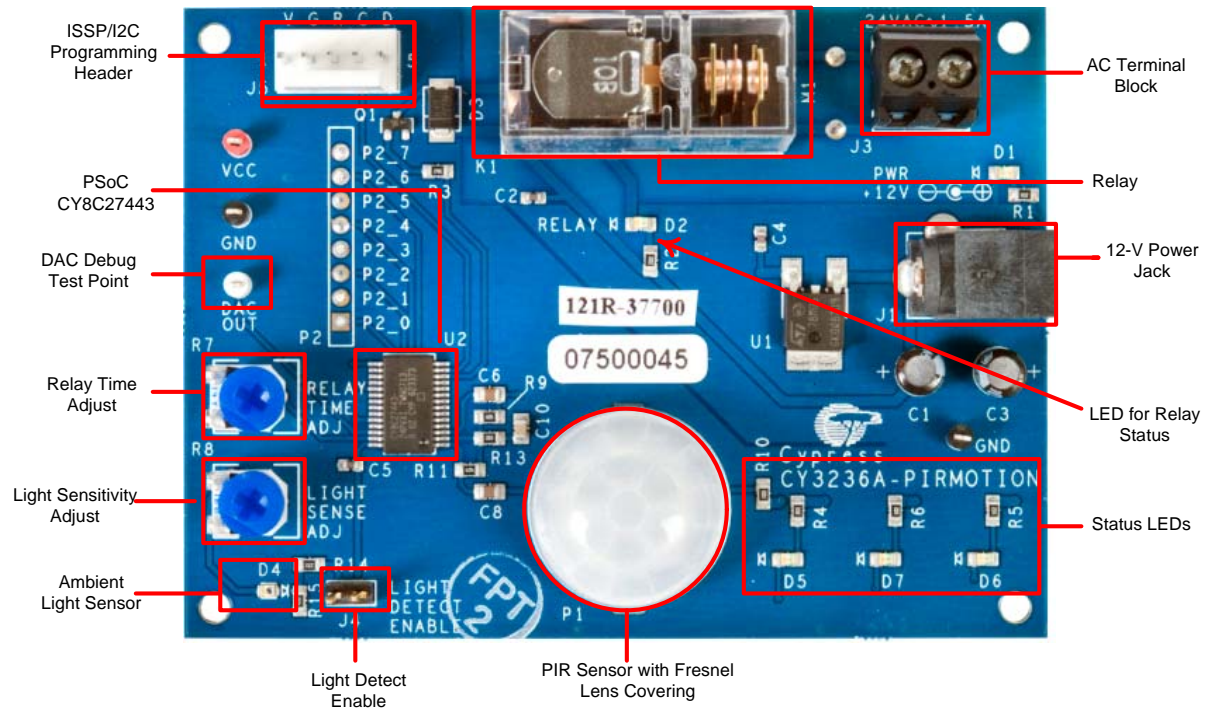

Figure 4-2. CY3236A-PIRMOTION Board



4.2 Functional Description

1. PSoC CY8C27443 Silicon

This PSoC device is configured to filter the analog signals from sensors, convert those signals to digital, and then use the digital signals to control hardware via a relay.

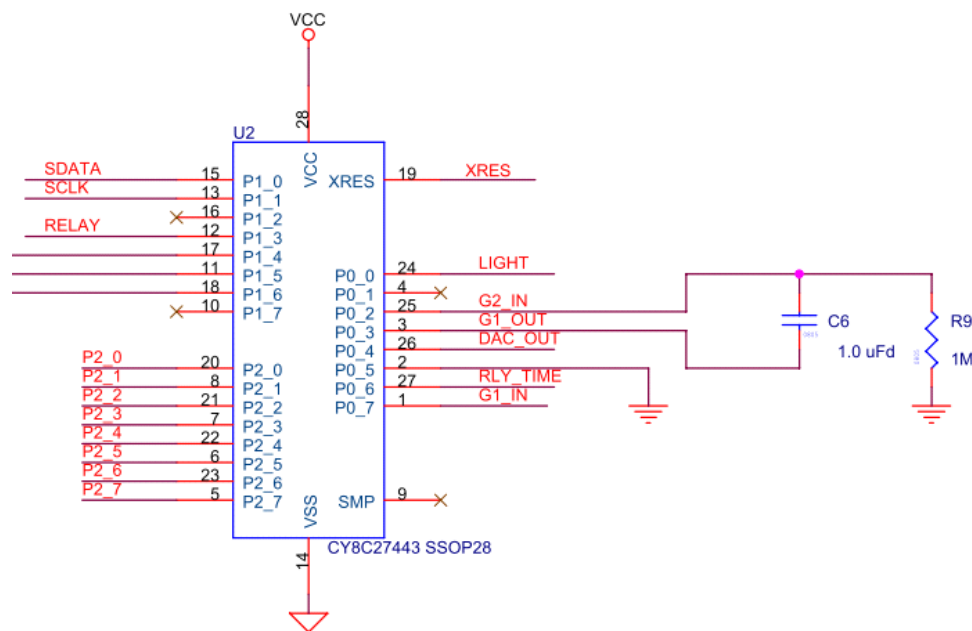

2. Power supply and Regulator

The kit can be powered by a 9 V to 12 V DC wall transformer with a positive tip barrel plug and 1 A current rating. The onboard regulator converts the input voltage to a regulated 5 V required by PSoC and other passive components. The relay unit is directly powered by the wall transformer.

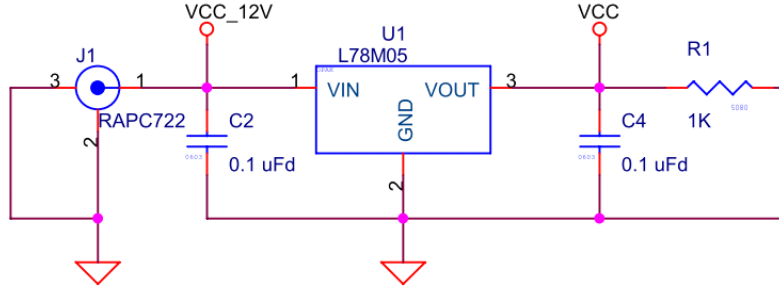

3. Ambient Light Sensor

The ambient light sensor consists of a phototransistor. This sensor data is used to detect the presence of ambient light and can override the function of the PIR sensor and keep the relay from turning on. In other words, the relay activation is now controlled by how much ambient light is present. The PIR signal can be ignored by the firmware, allowing the ambient light sensor to control the relay.

Refer to the Rohm PRM-075PT Phototransistor datasheet on the kit CD (<drive>:\Documentation\Datasheets) for additional information on the sensor..

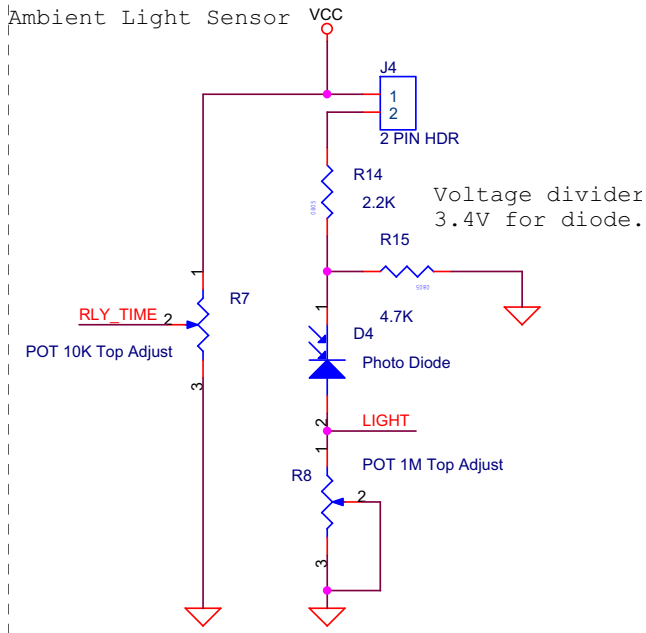

4. PIR Sensor

The CY3236A-PIRMOTION board consists of a Glolab's PIR325 PIR sensor. Humans, at normal body temperature, radiate infrared light waves at an approximate wavelength of 10 μm . A PIR sensor can detect this infrared radiation and convert it to an electric charge. This charge is buffered through a FET and can be converted to voltage variations using a load resistor. This analog data is filtered and converted to digital by PSoC. Refer to the Glolab PIR325 Infrared Motion Detector data-sheet on the kit CD for additional information on the sensor (<drive>:\Documentation\Data-sheets).

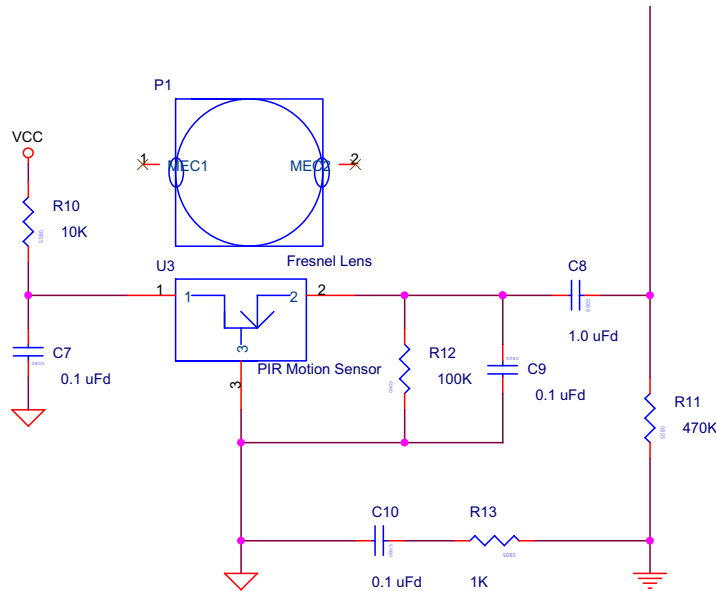

5. ISSP Programming Header

This header is used to program the device using the MiniProg programmer.

ISSP Programming Header

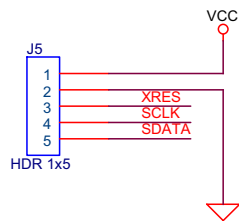

6. Test Points

The DAC Debug Test Point is used to view the output of the processed PIR signal. Connect a scope to the test point to view the sensor performance after the PSoC has filtered, amplified, and digitized the analog signal from the PIR sensor. Additional voltage test points are also provided to monitor the output voltage of the regulator.

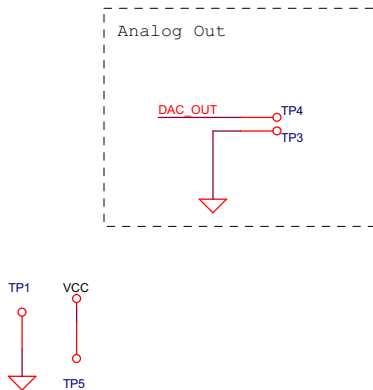

7. Status LEDs

There are four status LEDs to indicate the sensor and power status. D1 indicates the power status, D2 indicates the status of relay (lights up when relay is on), and D7 indicates the status of the PIR sensor. LEDs D5 and D6 are not used with the firmware included with this kit. However, they can be configured to perform other functions, such as sensing directional movement.

8. Potentiometer to Adjust Relay Time and Light Sensitivity

Potentiometer R7 is used to control the amount of time the relay is active. Adjust the relay ON time by turning the potentiometer so that the relay remains on for longer periods. To increase the relay ON time, turn the potentiometer counterclockwise. Turn it clockwise to decrease the 'On' time. R8 is used to adjust the circuit's sensitivity to ambient light. To make the board more sensitive to ambient light, turn the potentiometer clockwise. For less sensitivity, turn it counterclockwise. R8 is only active if the shunt J4 is connected. When the shunt is removed, ambient light detection is disabled.

9. Relay and AC Terminal Block

The on board really is a 12 V relay that is controlled by PSoC via a transistor as shown in the following circuit diagram. The normally open and common pins of Relay are connected to an AC terminal block. This unit allows you to connect a small AC powered device (the device is controlled by the relay). Such a device should include a small, low watt incandescent light bulb.

CAUTION Due to exposed pins on the back side of the board, connect no more than a 24 V AC to this terminal block.

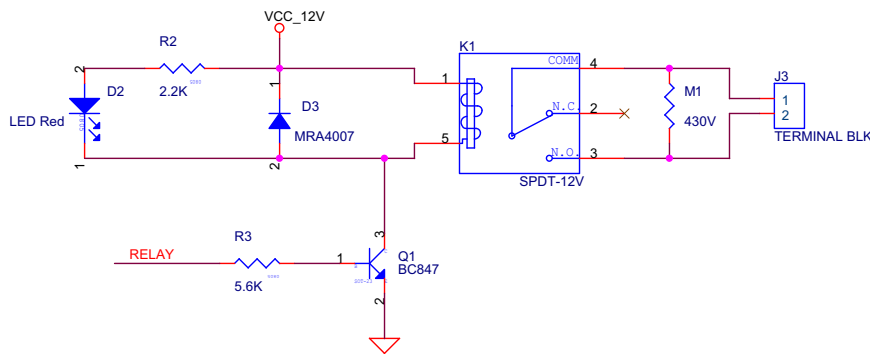

10.GPIO Expansion Port

The unused pins, Port 2 of the PSoC device, are brought out to an 8-pin, 0.100" pitch footprint, allowing access to this port.

5. Code Examples



All code examples are available on the CY3236A-PIRMOTION kit DVD or at this location:
<Install_directory>:\Cypress\CY3236A-PIRMOTION\<version>\Firmware

5.1 Project Description

This code example demonstrates Cypress's PSoC device's ability to control a PIR sensor to implement motion sensing applications such as automatic lighting controls, automatic door openers, security systems, kiosk wakeup, and activating wireless cameras.

The human body radiates a certain wavelength of infrared light in the realm of about 10 μm at normal body temperature. PIR sensing captures this radiated light. The PSoC filters the analog signals from the PIR sensor, converts those signals to digital, and then uses the digital signals to control the hardware depending on the application.

Additionally, PSoC processes the signal from the PIR, based on the inputs from the light sensor, and the Relay Time Preset controls the relay. The light sensor senses the ambient light and feeds the PSoC with an analog signal proportional to the ambient light. The Relay Time Preset control is a preset that provides a 0- to 5-V signal to the PSoC. The ambient light sensor can be used in applications such as automatic porch light control, where the load need not be switched on during daylight. Similarly, the relay time preset can be used to control the duration for which the relay remains on when infrared wavelengths are detected.

5.2 Device Configuration

The analog and digital user module placement within PSoC Designer are shown in [Figure 5-1](#). The project uses three analog blocks and two digital blocks for the actual PIR implementation. Two more analog blocks are used for a 9-bit DAC. The DAC9 is purely for debugging purposes.

- Analog-to-digital converter (ADCINCVR): This user module measures the signal generated by the PIR sensor. It also determines the voltage from the relay time preset and the voltage from the ambient light photo transistor.
- Digital-to-analog converter (DAC): This user module outputs the processed PIR signal and is intended for debugging purposes only.
- Programmable gain amplifier (PGA): Two of these user modules are used in this design. The first amplifies the PIR signal as it leaves the PIR sensor. The second performs three functions. It amplifies the PIR signal as a second stage following the first amplifier. It then buffers the voltage from the relay time preset to the ADC. Lastly, it amplifies the voltage signal generated by the ambient light photo transistor.
- 8-Bit Counter: The 8-bit counter is a time-based generator for sampling the PIR signal.

Figure 5-1. PSoC Designer Analog and Digital User Module Placement

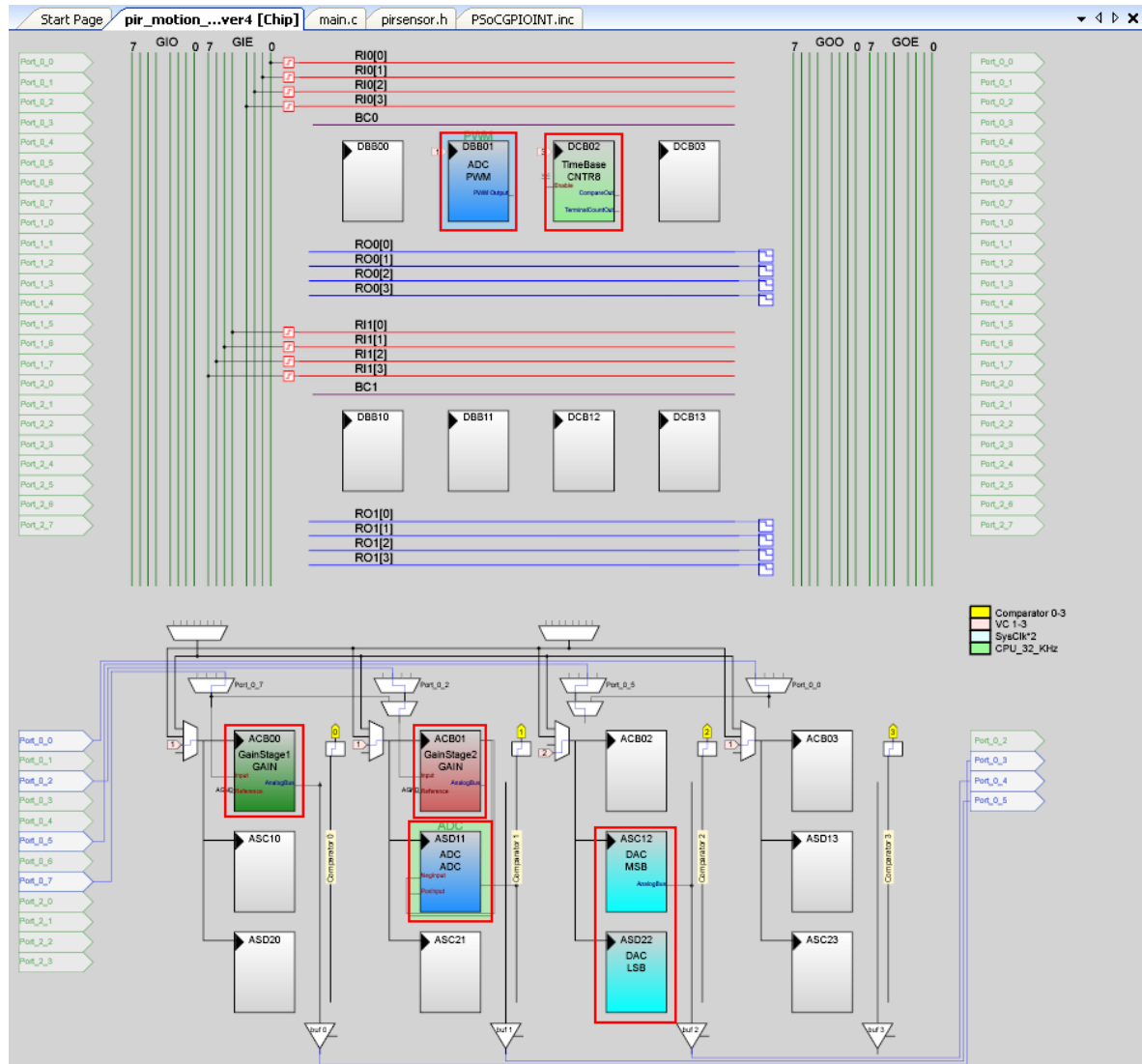

The firmware uses an infinite loop during which the PIR signal, relay-on time, and the output voltage of the ambient light sensor are sampled. Activation of the relay and motion LEDs are then determined by the values acquired from sampling.

5.2.1 Flowchart

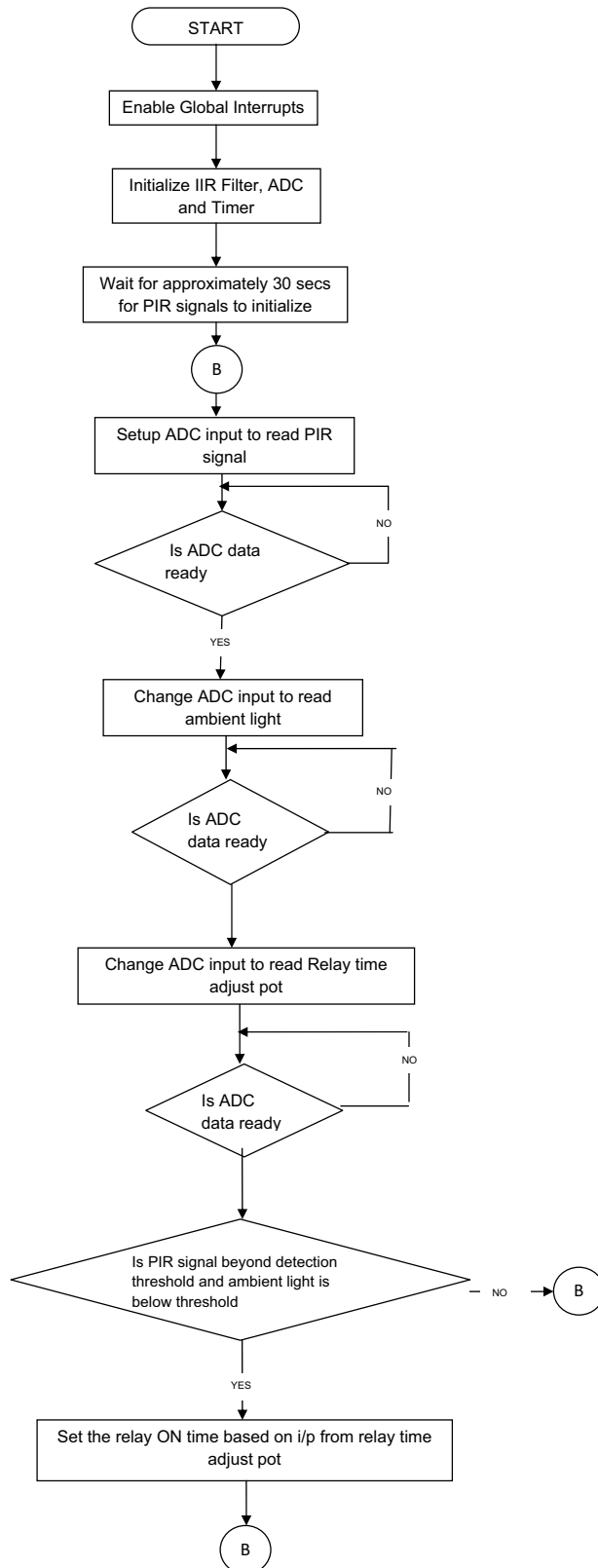

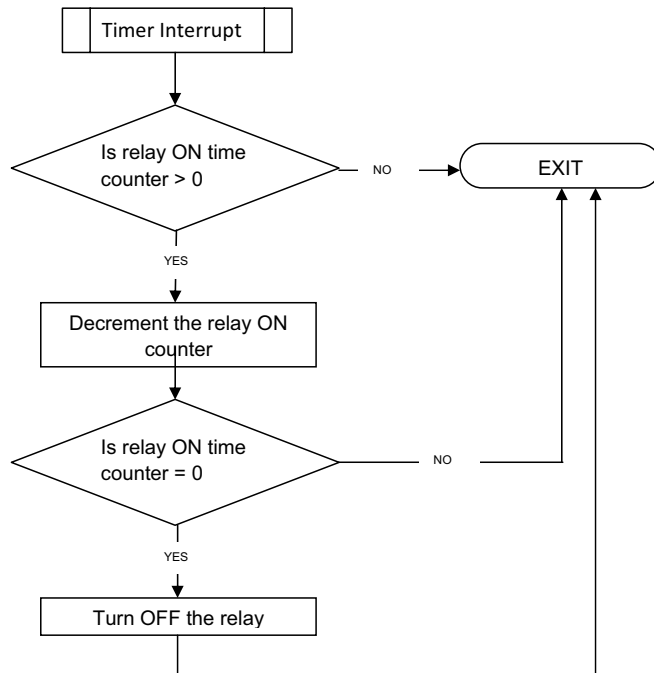

5.3 Verify Output - PIR Sensing

1. Ensure that jumper (shunt) is not placed on J4.
2. Power the board using the 12-V power adapter provided with the kit. After powering the board, wait for approximately 30 seconds for the firmware to initialize.
3. Upon initializing, move your hand over the PIR sensor; the relay K1 switches on. The LED D2 is also turned 'On' to indicate that relay is on. The relay remains in 'On' state as long as there is infrared motion detected. LED D7 lights up when the PIR device senses infrared radiation from the human body (hand).

Figure 5-2. Infrared Radiation Detection from Human Body

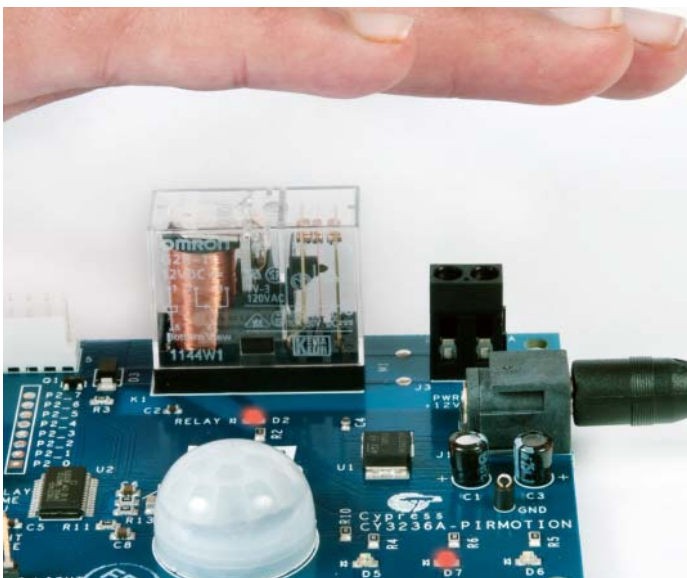

The amount of time the relay is active can be changed. Adjust the relay 'On' time by turning the potentiometer, R7, so that the relay remains on for longer periods. To increase the relay 'on' time, turn the potentiometer counterclockwise. Turn it clockwise to decrease the 'on' time.

5.4 Ambient Light Sensing

Figure 5-3. Ambient Light Sensing

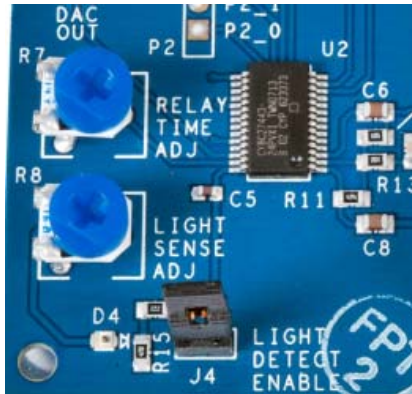

The evaluation board is also equipped with an ambient light sensor in the form of a photo transistor, DR. To use this feature, header J4 must be shunted. When this feature is enabled, the presence of ambient light can override the function of the PIR sensor and keep the relay from turning on. In other words, the relay activation can now be enabled depending on by how much ambient light is present. Based on how much light is present, the PIR signal can be ignored by the firmware, allowing the ambient light sensor to control the relay. To adjust the circuit's sensitivity to ambient light, tune the potentiometer, R8. To make the board more sensitive to ambient light, turn the potentiometer clockwise. For less sensitivity, turn it counterclockwise.

The board also contains a test point for the digital-to-analog conversion output of the PIR signal. Connect a scope to this test point to view the PIR signal that the PSoC has processed.

LEDs D5 and D6 are not used with the firmware included with this kit. However, they can be configured to perform other functions, such as sensing directional movement.

A. Appendix



The schematic, board layouts, and BOM are available on the kit CD or at:
 <Install_directory>:\Cypress\CY3236A-PIRMOTION\<version>\Hardware.

A.1 PIR Motion Sensor Board Schematic

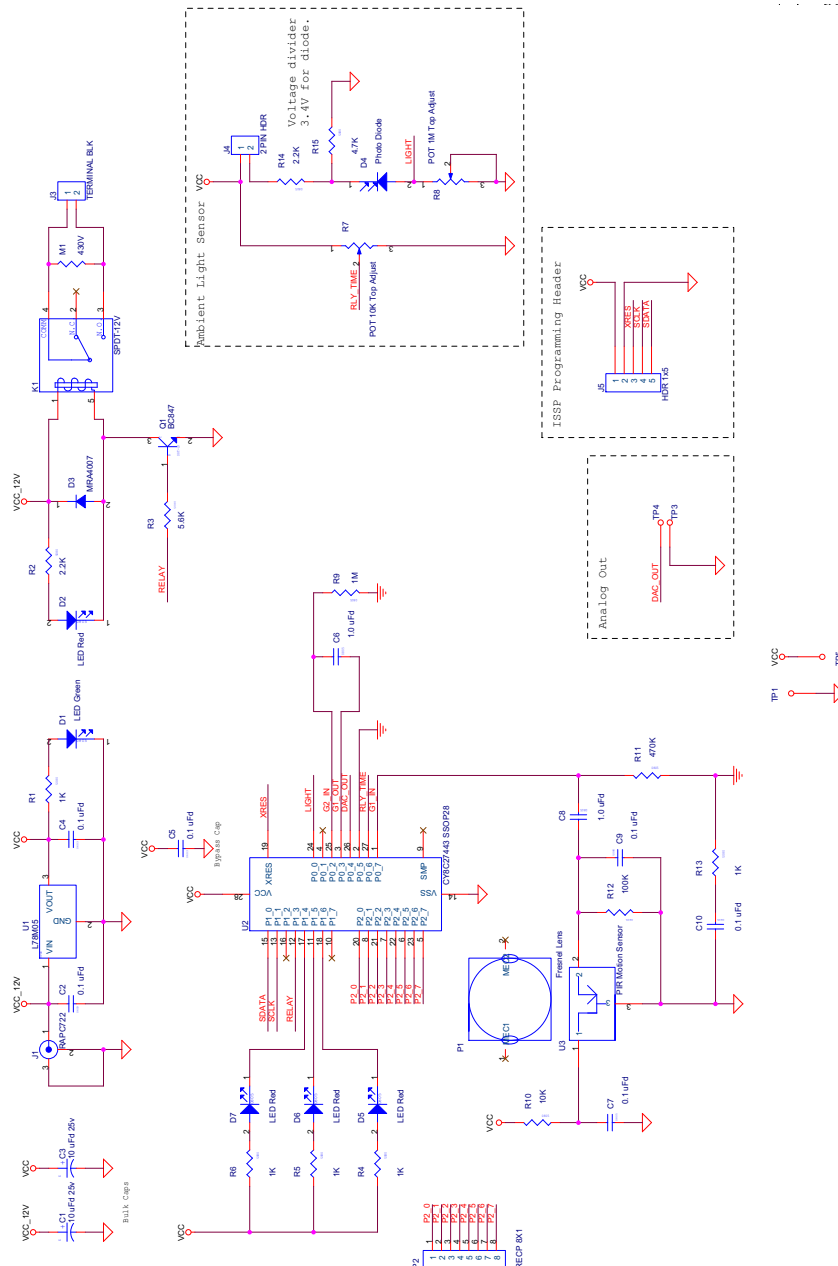

A.2 Board Images

Figure A-1. Layout Primary Side

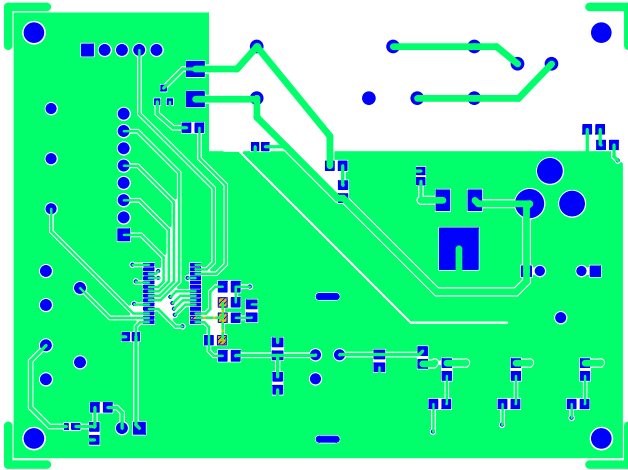
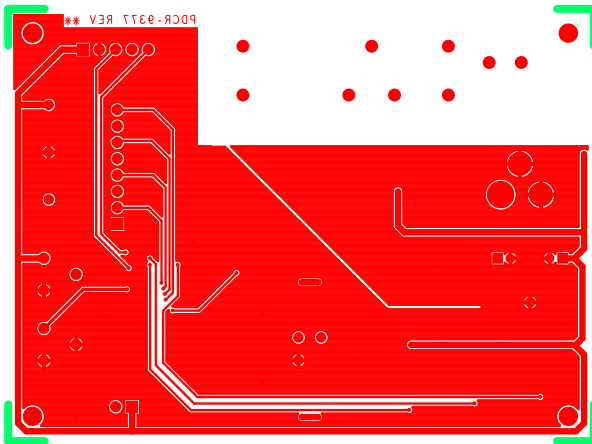

Figure A-2. Layout Secondary Side



A.3 Bill of Materials

Table A-1. BiOM

Item	Qty	CY Part Number	Reference	Description	Manufacturer	Mfr Part Number
1	2	710R-13952	C3,C1	CAP ELECT 10UF 25V KS RADIAL	Panasonic - ECG	ECE-A1EKS100
2	3	730R-11026	C2,C4,C5	CAP .1UF 50V CERAMIC Y5V 0603	Panasonic - ECG	ECJ-1VF1H104Z
3	2	730R-10963	C6,C8	CAP 1.0UF 16V CERAMIC Y5V 0805	Panasonic - ECG	ECJ-2VF1C105Z
4	3	730R-10074	C7,C9,C10	CAP .1UF 50V CERAMIC X7R 0805	Panasonic - ECG	ECJ-2YB1H104K
5	1	860R-13830	D1	LED GREEN CLEAR 0805 SMD	LITE-ON	LTST-C170GKT

Table A-1. BiOM (continued)

Item	Qty	CY Part Number	Reference	Description	Manufacturer	Mfr Part Number
6	4	860R-13823	D2,D5,D6,D7	LED RED Clear 0805 SMD	LITE-ON Inc	LTST-C170CKT
7	1	810R-13953	D3	DIODE GPP 1A 1000V DO41	Fairchild Semiconductor	1N4007
8	1	810R-13827	D4	PHOTOSENSOR MINI 3.3V 550NM 2QFN	Avago Technologies US Inc.	HSDL-9001
9	1	420R-11051	J1	CONN 2.1MM PWRJACK RT ANGLE PCB	Switchcraft Inc.	RAPC722
10	2	420R-13590	J4,J2	CONN HEADER VERT 2POS .100 30AU	AMP Division of TYCO	1-87215-0
11	1	420R-13954	J3	CONN TERM BLOCK PCB 5.0MM 2POS	Weidmuller	1715250000
12	1	420R-10516	J5	CONN HEADER 5POS 0.1 VERT KEYED	Molex	22-23-2051
13	1	800R-13955	K1	RELAY PCB SPDT 10A 12VDC	Omron	G2R-1-DC12
14	1	800R-13958	P1	FRESNEL LENS, ROUND, 21mm	3Dlens	5114
15	1	830R-13956	Q1	TRANS NPN LP 100MA 30V SOT23	ON Semiconductor	BC847
16	5	630R-10733	R1,R4,R5,R6,R13	RES 1K OHM 1/10W 5% 0805 SMD	Panasonic - ECG	ERJ-6GEYJ102V
17	1	630R-10534	R2	RES 2.2K OHM 1/10W 5% 0805 SMD	Panasonic - ECG	ERJ-6GEYJ222V
18	2	630R-10246	R10,R3	RES 10K OHM 1/10W 5% 0805 SMD	Panasonic - ECG	ERJ-6GEYJ103V
19	1	670R-13826	R7	POT 10K OHM 6MM CER-MET HORZ	CTS Corporation Resistor/ Electrocomponents	307UC103ER
20	1	670R-13828	R8	POT 1.0M OHM 6MM CERMET HORZ	CTS Corporation Resistor/ Electrocomponents	307UC105ER
21	1	630R-10347	R9	RES 1M OHM 1/10W 5% 0805 SMD	Panasonic - ECG	ERJ-6GEYJ105V
22	1	640R-13825	R11	RES 470K OHM 1/8W 5% 0805 SMD	Panasonic - ECG	ERJ-6GEYJ474V
23	1	630R-10197	R12	RES 100K OHM 1/16W 5% 0805 SMD	Panasonic - ECG	ERJ-6GEYJ104V
24	1	500R-13829	U1	IC REG VOLT POS 500MA 5V DPAK	STMicroelectronics	L78M05CDT-TR
25	1	CY8C27443-24PXI	U2	IC PROGRAMMABLE SOC DIP28	Cypress Semiconductor	CY8C27443-24PXI
26	1	870R-13824	U3	PIR Motion Sensor, 3POS	GloLab Corp.	PIR325
27	1	PDCR-9377 **	PCB	PRINTED CIRCUIT BOARD	Cypress Semiconductor	PDCR-9377 **
28	1		LABEL1	PCA #		121R-37700 **
DO NOT INSTALL						
29	1	840R-13957	M1	VARISTOR 430V 1.7J 3MM AXIAL T/R	Littlefuse	V430MT7B

Looking for pricing, stock, or lifecycle information?

Click below to explore more details on WIN SOURCE:

-  [View CY3236A-PIRMOTION on WIN SOURCE](#)
-  [Infineon Technologies](#) Information

Optimize Your Supply Chain with WIN SOURCE Solutions

-  Global Sourcing Solution
-  Obsolete Management
-  Cost Control Management
-  Shortage Management
-  Alternative Solution
-  Excess Inventory Management