



**THE DATASHEET OF
CY7S1061GE30-10BVXI**





Please note that Cypress is an Infineon Technologies Company.

The document following this cover page is marked as “Cypress” document as this is the company that originally developed the product. Please note that Infineon will continue to offer the product to new and existing customers as part of the Infineon product portfolio.

Continuity of document content

The fact that Infineon offers the following product as part of the Infineon product portfolio does not lead to any changes to this document. Future revisions will occur when appropriate, and any changes will be set out on the document history page.

Continuity of ordering part numbers

Infineon continues to support existing part numbers. Please continue to use the ordering part numbers listed in the datasheet for ordering.

16-Mbit (1 M words × 16 bit) Static RAM with PowerSnooze™ and ECC

Features

- High speed
 - $t_{AA} = 10$ ns
- Ultra-low power PowerSnooze™^[1] device
 - Deep Sleep (DS) current $I_{DS} = 22$ - μ A maximum
- Low active and standby currents
 - $I_{CC} = 90$ -mA typical
 - $I_{SB2} = 20$ -mA typical
- Wide operating voltage range: 1.65 V to 2.2 V, 2.2 V to 3.6 V, and 4.5 V to 5.5 V
- Embedded error-correcting code (ECC) for single-bit error correction
- 1.0-V data retention
- Transistor-transistor logic (TTL) compatible inputs and outputs
- Error indication (ERR) pin to indicate 1-bit error detection and correction
- Available in Pb-free 48-pin TSOP I, 54-pin TSOP II, and 48-ball VFBGA packages

Functional Description

The CY7S1061G/CY7S1061GE is a high-performance CMOS fast static RAM organized as 1,048,576 words by 16 bits. This device features fast access times (10 ns) and a unique ultra-low power Deep Sleep mode. With Sleep mode currents as low as 22 μ A, the CY7S1061G device combines the best features of fast and low-power SRAM in industry-standard package options. The device also features embedded ECC^[2]. ECC logic can detect and correct single-bit error in the accessed location. The CY7S1061GE device includes an ERR pin that signals an error-detection and correction event during a read cycle.

To access devices with a single-chip enable input, assert the chip enable input (CE) LOW. To access dual chip enable devices, assert both chip enable inputs – CE₁ as LOW and CE₂ as HIGH.

To perform data writes, assert the Write Enable (\overline{WE}) input LOW, and provide the data and address on device data pins (I/O₀ through I/O₁₅) and address pins (A₀ through A₁₉) respectively. The Byte High Enable (BHE) and Byte Low Enable (BLE) inputs control byte writes, and write data on the corresponding I/O lines to the memory location specified. BHE controls I/O₈ through I/O₁₅ and BLE controls I/O₀ through I/O₇.

To perform data reads, assert the Output Enable (\overline{OE}) input and provide the required address on the address lines. Read data is accessible on the I/O lines (I/O₀ through I/O₁₅). You can perform byte accesses by asserting the required byte enable signal (BHE or BLE) to read either the upper byte or the lower byte of data from the specified address location.

All I/Os (I/O₀ through I/O₁₅) are placed in a high-impedance state when the device is deselected (CE HIGH for single chip enable devices and CE₁ HIGH and CE₂ LOW for dual chip enable devices), or the control signals (\overline{OE} , BLE, BHE) are de-asserted.

The device is placed in a low power Deep Sleep mode when the Deep Sleep pin (DS) is LOW. In this state, the device is disabled for normal operation and is placed in a data retention mode. The device can be activated by de-asserting the Deep Sleep pin (\overline{DS} HIGH).

The CY7S1061G/CY7S1061G is available in 48-pin TSOP I, 54-pin TSOP II, and 48-ball VFBGA packages.

For a complete list of related resources, [click here](#).

Product Portfolio

Product	Range	V _{CC} Range (V)	Speed (ns)	Current Consumption					
				Operating I _{CC} (mA)		Standby, I _{SB2} (mA)		Deep-Sleep Current (μ A)	
				f = f _{max}		Typ ^[3]	Max	Typ ^[1]	Max
				Typ ^[3]	Max				
CY7S1061G18	Industrial	1.65 V–2.2 V	15	70	80	20	30	8	22
CY7S1061G(E)30		2.2 V–3.6 V	10	90	110				
CY7S1061G		4.5–5.5 V	10	90	110				

Notes

1. Refer to AN89371 for details on PowerSnooze™ feature of this device.
2. This device does not support automatic write-back on error detection.
3. Typical values are included only for reference and are not guaranteed or tested. Typical values are measured at V_{CC} = 1.8 V (for a V_{CC} range of 1.65 V–2.2 V), V_{CC} = 3 V (for a V_{CC} range of 2.2 V–3.6 V), and V_{CC} = 5 V (for a V_{CC} range of 4.5 V–5.5 V), T_A = 25 °C.

Logic Block Diagram – CY7S1061G

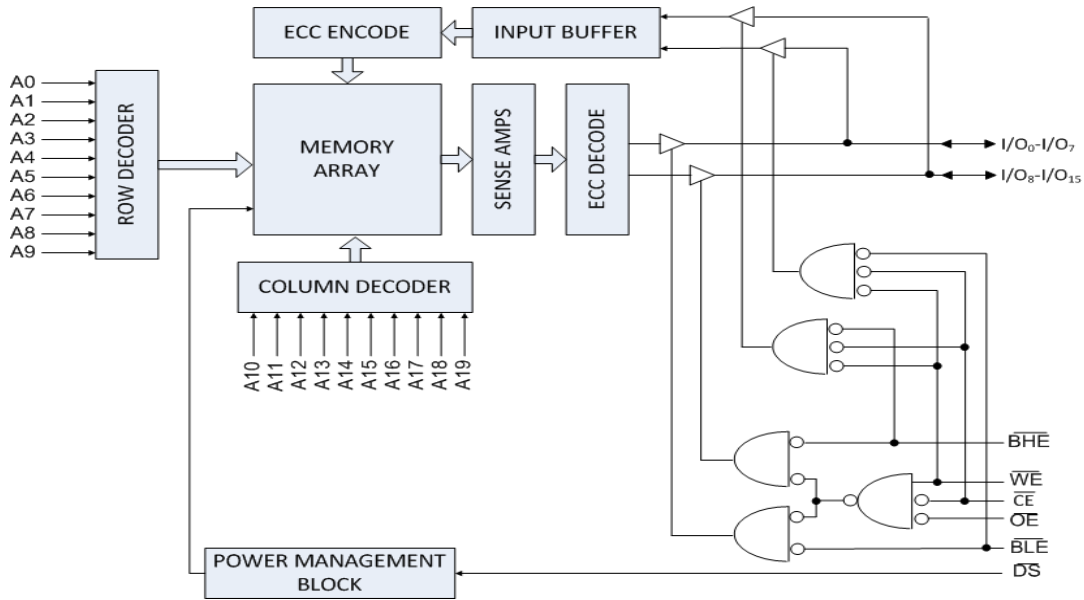

Logic Block Diagram – CY7S1061GE

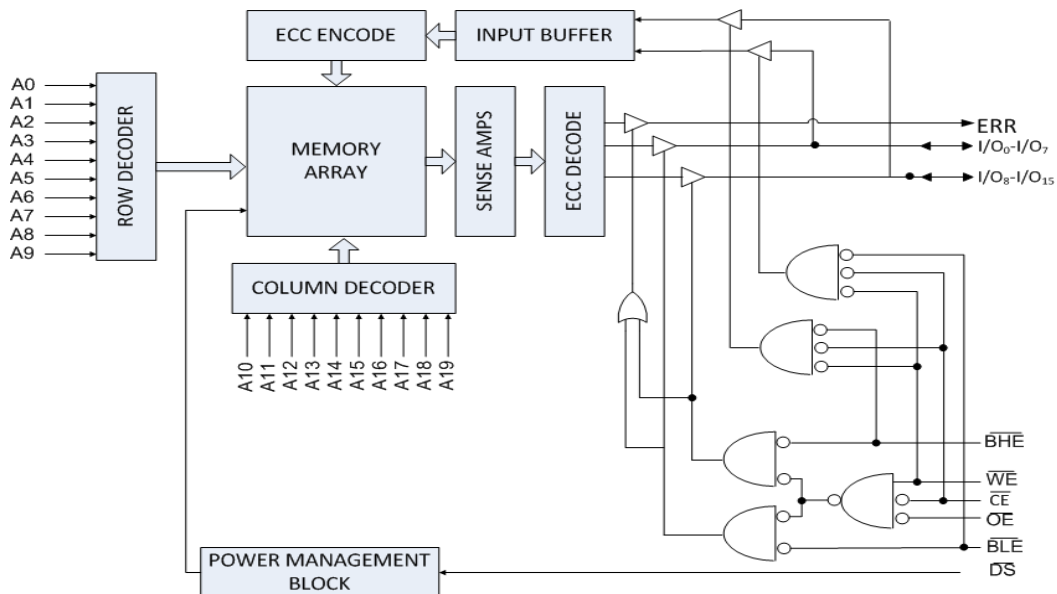

Contents

Pin Configurations	4	Ordering Information	17
Maximum Ratings	7	Ordering Code Definitions	17
Operating Range	7	Package Diagrams	18
DC Electrical Characteristics	7	Acronyms	21
Capacitance	8	Document Conventions	21
Thermal Resistance	8	Units of Measure	21
AC Test Loads and Waveforms	8	Document History Page	22
Data Retention Characteristics	9	Sales, Solutions, and Legal Information	23
Data Retention Waveform	9	Worldwide Sales and Design Support	23
Deep-Sleep Mode Characteristics	10	Products	23
AC Switching Characteristics	11	PSoC® Solutions	23
Switching Waveforms	12	Cypress Developer Community	23
Truth Table	16	Technical Support	23
ERR Output – CY7S1061GE	16		

Pin Configurations

Figure 1. 48-ball VFBGA (6 × 8 × 1.0 mm) Pinout (Top View) ^[4]

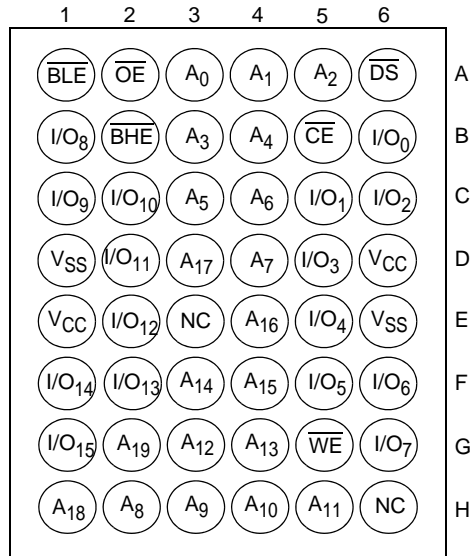
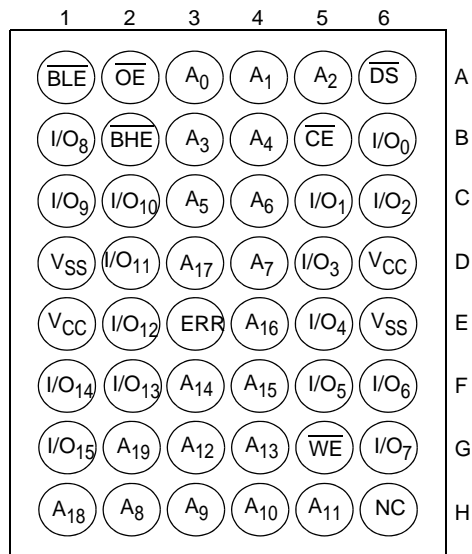

Figure 2. 48-ball VFBGA (6 × 8 × 1.0 mm) Pinout with ERR (Top View) ^[4]



Note

- 4. NC pins are not connected internally to the die.

Pin Configurations (continued)

Figure 3. 54-pin TSOP II (22.4 × 11.84 × 1.0 mm) Pinout ^[5]

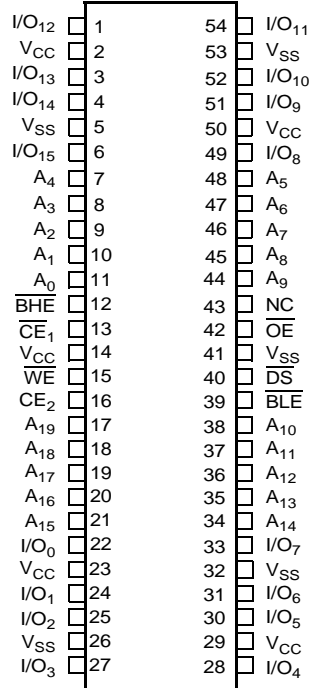

Note

- NC pins are not connected internally to the die.

Pin Configurations (continued)

Figure 4. 48-pin TSOP I (12 x 18.4 x 1 mm) Pinout (Top View) [6]



Figure 5. 48-pin TSOP I (12 x 18.4 x 1 mm) Pinout, ERR Output at Pin 6 (Top View)

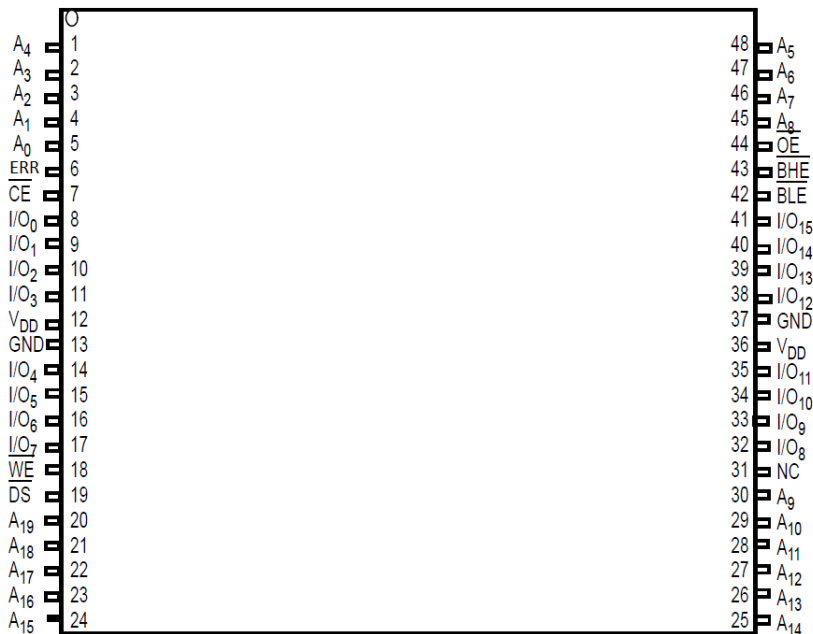

Note

6. NC pins are not connected internally to the die.

Maximum Ratings

Exceeding maximum ratings may impair the useful life of the device. These user guidelines are not tested.

- Storage temperature -65 °C to +150 °C
- Ambient temperature with power applied -55 °C to +125 °C
- Supply voltage on V_{CC} relative to GND ^[7] -0.5 V to V_{CC} + 0.5 V
- DC voltage applied to outputs in High Z State ^[7] -0.5 V to V_{CC} + 0.5 V

- DC input voltage ^[7] -0.5 V to V_{CC} + 0.5 V
- Current into outputs (LOW) 20 mA
- Static discharge voltage (MIL-STD-883, Method 3015) > 2001 V
- Latch-up current > 140 mA

Operating Range

Range	Ambient Temperature	V _{CC}
Industrial	-40 °C to +85 °C	1.65 V to 2.2 V, 2.2 V to 3.6 V, 4.5 V to 5.5 V

DC Electrical Characteristics

Over the operating range of -40 °C to +85 °C

Parameter	Description	Test Conditions	10 ns / 15 ns			Unit	
			Min	Typ ^[8]	Max		
V _{OH}	Output HIGH voltage	1.65 V to 2.2 V	V _{CC} = Min, I _{OH} = -0.1 mA	1.4	-	-	V
		2.2 V to 2.7 V	V _{CC} = Min, I _{OH} = -1.0 mA	2.0	-	-	
		2.7 V to 3.0 V	V _{CC} = Min, I _{OH} = -4.0 mA	2.2	-	-	
		3.0 V to 3.6 V	V _{CC} = Min, I _{OH} = -4.0 mA	2.4	-	-	
		4.5 V to 5.5 V	V _{CC} = Min, I _{OH} = -4.0 mA	2.4	-	-	
		4.5 V to 5.5 V	V _{CC} = Min, I _{OH} = -0.1 mA	V _{CC} - 0.4 ^[9]	-	-	
V _{OL}	Output LOW voltage	1.65 V to 2.2 V	V _{CC} = Min, I _{OL} = 0.1 mA	-	-	0.2	V
		2.2 V to 2.7 V	V _{CC} = Min, I _{OL} = 2 mA	-	-	0.4	
		2.7 V to 3.6 V	V _{CC} = Min, I _{OL} = 8 mA	-	-	0.4	
		4.5 V to 5.5 V	V _{CC} = Min, I _{OL} = 8 mA	-	-	0.4	
V _{IH} ^[7, 10]	Input HIGH voltage	1.65 V to 2.2 V	-	1.4	-	V _{CC} + 0.2	V
		2.2 V to 2.7 V	-	2.0	-	V _{CC} + 0.3	
		2.7 V to 3.6 V	-	2.0	-	V _{CC} + 0.3	
		4.5 V to 5.5 V	-	2.2	-	V _{CC} + 0.5	
V _{IL} ^[7, 10]	Input LOW voltage	1.65 V to 2.2 V	-	-0.2	-	0.4	V
		2.2 V to 2.7 V	-	-0.3	-	0.6	
		2.7 V to 3.6 V	-	-0.3	-	0.8	
		4.5 V to 5.5 V	-	-0.5	-	0.8	
I _{IX}	Input leakage current	GND ≤ V _{IN} ≤ V _{CC} (for all pins except \overline{DS}) V _{IN} = GND (or) V _{IN} ≥ V _{IH} (for DS pin only)	-1.0	-	+1.0	μA	
I _{OZ}	Output leakage current	GND ≤ V _{OUT} ≤ V _{CC} , Output disabled	-1.0	-	+1.0	μA	
I _{CC}	V _{CC} operating supply current	V _{CC} = Max, I _{OUT} = 0 mA, CMOS levels	f = 100 MHz f = 66.7 MHz	- -	90.0 70.0	110.0 80.0	mA
I _{SB1}	Standby current – TTL inputs	Max V _{CC} , $\overline{CE}^{[11]}$ ≥ V _{IH} , V _{IN} ≥ V _{IH} or V _{IN} ≤ V _{IL} , f = f _{MAX}	-	-	-	40.0	mA
I _{SB2}	Standby current – CMOS inputs	Max V _{CC} , $\overline{CE}^{[11]}$ ≥ V _{CC} - 0.2 V, \overline{DS} ≥ V _{CC} - 0.2 V, V _{IN} ≥ V _{CC} - 0.2 V or V _{IN} ≤ 0.2 V, f = 0	-	-	20.0	30.0	mA
I _{DS}	Deep-Sleep current	Max V _{CC} , $\overline{CE}^{[11]}$ ≥ V _{CC} - 0.2 V, \overline{DS} ≤ 0.2 V, V _{IN} ≥ V _{CC} - 0.2 V or V _{IN} ≤ 0.2 V, f = 0	-	-	8.0	22.0	μA

Notes

7. V_{IL} (min) = -2.0 V and V_{IH} (max) = V_{CC} + 2 V for pulse durations of less than 20 ns.
8. Indicates the value for the center of distribution at 3.0 V, 25 °C and not 100% tested. Typical values are measured at V_{CC} = 1.8 V (for a V_{CC} range of 1.65 V–2.2 V), V_{CC} = 3 V (for a V_{CC} range of 2.2 V–3.6 V), and V_{CC} = 5 V (for a V_{CC} range of 4.5 V–5.5 V), T_A = 25 °C.
9. This parameter is guaranteed by design and is not tested.
10. For \overline{DS} pin, V_{IH} (min) is V_{CC} - 0.2 V and V_{IL} (max) is 0.2 V.
11. For all dual chip enable devices, \overline{CE} is the logical combination of \overline{CE}_1 and CE₂. When \overline{CE}_1 is LOW and CE₂ is HIGH, \overline{CE} is LOW; when \overline{CE}_1 is HIGH or CE₂ is LOW, \overline{CE} is HIGH.

Capacitance

Parameter ^[12]	Description	Test Conditions	All packages	Unit
C _{IN}	Input capacitance	T _A = 25 °C, f = 1 MHz, V _{CC} (typ)	10	pF
C _{OUT}	I/O capacitance		10	pF

Thermal Resistance

Parameter ^[12]	Description	Test Conditions	48-ball VFBGA	54-pin TSOP II	48-pin TSOP I	Unit
Θ _{JA}	Thermal resistance (junction to ambient)	Still air, soldered on a 3 × 4.5 inch, four layer printed circuit board	31.50	93.63	57.99	°C/W
Θ _{JC}	Thermal resistance (junction to case)		15.75	21.58	13.42	°C/W

AC Test Loads and Waveforms

Figure 6. AC Test Loads and Waveforms^[13]

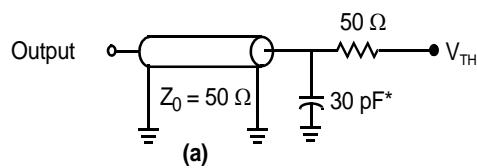

* Capacitive Load Consists of all Components of the Test Environment

High-Z Characteristics:

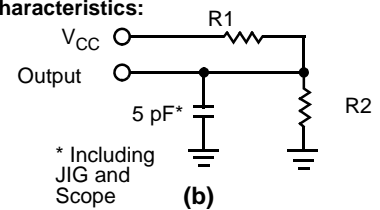

* Including JIG and Scope

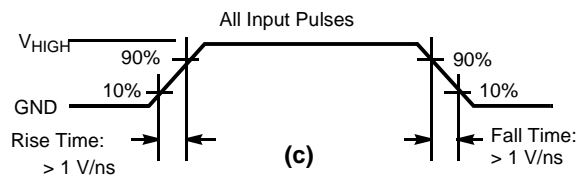

Parameters	1.8 V	3.0 V	5.0 V	Unit
R1	1667	317	317	Ω
R2	1538	351	351	Ω
V _{TH}	V _{CC} /2	1.5	1.5	V
V _{HIGH}	1.8	3.0	3.0	V

Data Retention Characteristics

Over the Operating Range of $-40\text{ }^{\circ}\text{C}$ to $+85\text{ }^{\circ}\text{C}$

Parameter	Description	Conditions	Min	Max	Unit
V_{DR}	V_{CC} for data retention		1.0	–	V
I_{CCDR}	Data retention current	$V_{CC} = V_{DR}$, $\overline{CE} \geq V_{CC} - 0.2\text{ V}$, $\overline{DS} \geq V_{CC} - 0.2\text{ V}$, $V_{IN} \geq V_{CC} - 0.2\text{ V}$ or $V_{IN} \leq 0.2\text{ V}$	–	30.0	mA
$t_{CDR}^{[14]}$	Chip deselect to data retention time		0	–	ns
$t_R^{[14]}$	Operation recovery time	$2.2\text{ V} < V_{CC} \leq 5.5\text{ V}$	10.0	–	ns
		$V_{CC} \leq 2.2\text{ V}$	15.0	–	ns

Data Retention Waveform

Figure 7. Data Retention Waveform^[15, 16]

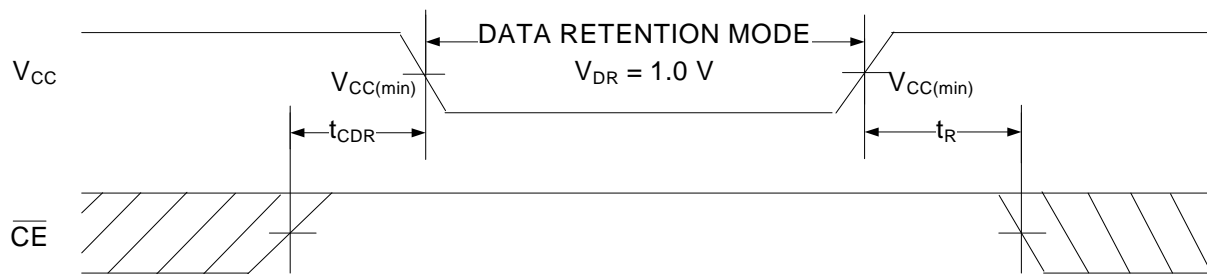

Notes

14. These parameters are guaranteed by design and are not tested.

15. Full device operation requires linear V_{CC} ramp from V_{DR} to $V_{CC}(\text{min}) \geq 100\text{ }\mu\text{s}$ or stable at $V_{CC}(\text{min}) \geq 100\text{ }\mu\text{s}$.

16. For all dual chip enable devices, \overline{CE} is the logical combination of \overline{CE}_1 and CE_2 . When \overline{CE}_1 is LOW and CE_2 is HIGH, \overline{CE} is LOW; when \overline{CE}_1 is HIGH or CE_2 is LOW, \overline{CE} is HIGH.

Deep-Sleep Mode Characteristics

Over the Operating Range of -40 °C to +85 °C

Parameter	Description	Conditions	Min	Max	Unit
I_{DS}	Deep Sleep Mode current	$V_{CC} = V_{CC}(\text{max}), \overline{CE}^{[17]} \geq V_{CC} - 0.2 \text{ V}, \overline{DS} \leq 0.2 \text{ V}, V_{IN} \geq V_{CC} - 0.2 \text{ V}$ or $V_{IN} \leq 0.2 \text{ V}$	-	22	μA
$t_{CEDS}^{[17, 18]}$	Time between de-assertion of $\overline{CE}^{[17]}$ and assertion of \overline{DS}		100	-	ns
$t_{DS}^{[17, 18]}$	\overline{DS} assertion to Deep Sleep mode transition time		-	1	ms
$t_{DSCE}^{[17, 18]}$	Time between de-assertion of \overline{DS} and assertion of $\overline{CE}^{[17]}$		1	-	ms

Figure 8. Active, Standby, and Deep-Sleep Operation Modes ^[19]

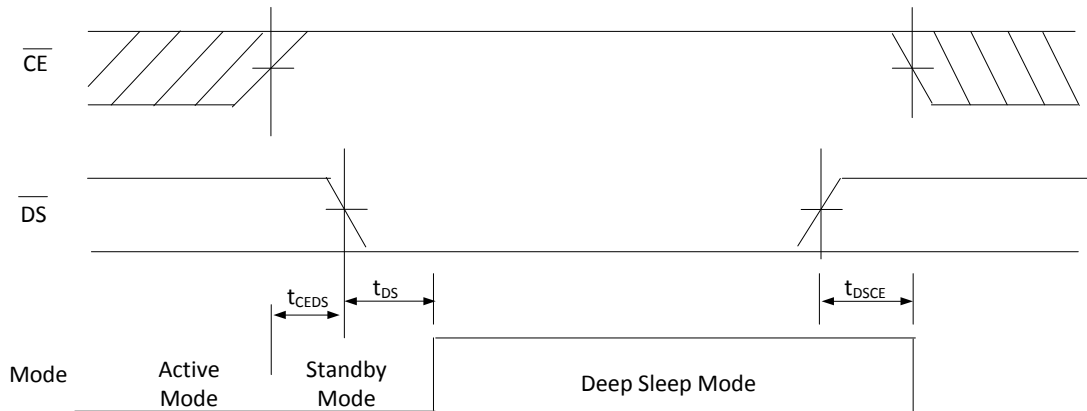

Notes

17. Address, data, and control lines should not toggle within t_{DS} . They should be fixed to one of the logic levels - V_{IH} or V_{IL} .

18. These parameters are guaranteed by design and are not tested.

19. For all dual chip enable devices, \overline{CE} is the logical combination of \overline{CE}_1 and CE_2 . When \overline{CE}_1 is LOW and CE_2 is HIGH, \overline{CE} is LOW; when \overline{CE}_1 is HIGH or CE_2 is LOW, \overline{CE} is HIGH.

AC Switching Characteristics

Over the operating range of $-40\text{ }^{\circ}\text{C}$ to $+85\text{ }^{\circ}\text{C}$

Parameter [20, 21]	Description	10 ns		15 ns		Unit
		Min	Max	Min	Max	
Read Cycle						
t_{power}	V_{CC} (stable) to the first access [22, 23]	100.0	–	100.0	–	μs
t_{RC}	Read cycle time	10.0	–	15.0	–	ns
t_{AA}	Address to data valid / ERR valid	–	10.0	–	15.0	ns
t_{OHA}	Data / ERR hold from address change	3.0	–	3.0	–	ns
t_{ACE}	$\overline{\text{CE}}$ LOW to data valid / ERR valid	–	10.0	–	15.0	ns
t_{DOE}	$\overline{\text{OE}}$ LOW to data valid / ERR valid	–	5.0	–	8.0	ns
t_{LZOE}	$\overline{\text{OE}}$ LOW to low Z [24, 25, 26]	0	–	1.0	–	ns
t_{HZOE}	$\overline{\text{OE}}$ HIGH to high Z [24, 25, 26]	–	5.0	–	8.0	ns
t_{LZCE}	$\overline{\text{CE}}$ LOW to low Z [24, 25, 26, 27]	3.0	–	3.0	–	ns
t_{HZCE}	$\overline{\text{CE}}$ HIGH to high Z [24, 25, 26, 27]	–	5.0	–	8.0	ns
t_{PU}	$\overline{\text{CE}}$ LOW to power-up [23]	0	–	0	–	ns
t_{PD}	$\overline{\text{CE}}$ HIGH to power-down [23]	–	10.0	–	15.0	ns
t_{DBE}	Byte enable to data valid	–	5.0	–	8.0	ns
t_{LZBE}	Byte enable to low Z [24, 25]	0	–	1.0	–	ns
t_{HZBE}	Byte disable to high Z [24, 25]	–	5.0	–	8.0	ns
Write Cycle [28, 29]						
t_{WC}	Write cycle time	10.0	–	15.0	–	ns
t_{SCE}	$\overline{\text{CE}}$ LOW to write end [27]	7.0	–	12.0	–	ns
t_{AW}	Address setup to write end	7.0	–	12.0	–	ns
t_{HA}	Address hold from write end	0	–	0	–	ns
t_{SA}	Address setup to write start	0	–	0	–	ns
t_{PWE}	$\overline{\text{WE}}$ pulse width	7.0	–	12.0	–	ns
t_{SD}	Data setup to write end	5.0	–	8.0	–	ns
t_{HD}	Data hold from write end	0	–	0	–	ns
t_{LZWE}	$\overline{\text{WE}}$ HIGH to low Z [24, 25, 26]	3.0	–	3.0	–	ns
t_{HZWE}	$\overline{\text{WE}}$ LOW to high Z [24, 25, 26]	–	5.0	–	8.0	ns
t_{BW}	Byte Enable to End of Write	7.0	–	12.0	–	ns

Notes

20. Test conditions assume signal transition time (rise/fall) of 3 ns or less, timing reference levels of 1.5 V (for $V_{\text{CC}} \geq 3\text{ V}$) and $V_{\text{CC}}/2$ (for $V_{\text{CC}} < 3\text{ V}$), and input pulse levels of 0 to 3 V (for $V_{\text{CC}} \geq 3\text{ V}$), and 0 to V_{CC} (for $V_{\text{CC}} < 3\text{ V}$). Test conditions for the read cycle use the output loading shown in part (a) of Figure 6 on page 8, unless specified otherwise.
21. DS must be HIGH for chip access. Refer to AN89371 for details.
22. t_{POWER} gives the minimum amount of time that the power supply is at stable V_{CC} until the first memory access is performed.
23. These parameters are guaranteed by design and are not tested.
24. t_{HZOE} , t_{HZCE} , t_{HZWE} , and t_{HZBE} are specified with a load capacitance of 5 pF, as shown in part (b) of Figure 6 on page 8. Hi-Z, Lo-Z transition is measured $\pm 200\text{ mV}$ from steady state voltage.
25. At any temperature and voltage condition, t_{HZCE} is less than t_{LZCE} , t_{HZBE} is less than t_{LZBE} , t_{HZOE} is less than t_{LZOE} , and t_{HZWE} is less than t_{LZWE} for any device.
26. Tested initially and after any design or process changes that may affect these parameters.
27. For all dual chip enable devices, $\overline{\text{CE}}$ is the logical combination of $\overline{\text{CE}}_1$ and $\overline{\text{CE}}_2$. When $\overline{\text{CE}}_1$ is LOW and $\overline{\text{CE}}_2$ is HIGH, $\overline{\text{CE}}$ is LOW; when $\overline{\text{CE}}_1$ is HIGH or $\overline{\text{CE}}_2$ is LOW, $\overline{\text{CE}}$ is HIGH.
28. The internal write time of the memory is defined by the overlap of $\overline{\text{WE}} = V_{\text{IL}}$, $\overline{\text{CE}} = V_{\text{IL}}$, and $\overline{\text{BHE}}$ or $\overline{\text{BLE}} = V_{\text{IL}}$. These signals must be LOW to initiate a write, and the HIGH transition of any of these signals can terminate the operation. The input data setup and hold timing should be referenced to the edge of the signal that terminates the write.
29. The minimum write pulse width for Write Cycle No. 2 ($\overline{\text{WE}}$ controlled, $\overline{\text{OE}}$ LOW) should be the sum of t_{HZWE} and t_{SD} .

Switching Waveforms

Figure 9. Read Cycle No. 1 of CY7S1061G (Address Transition Controlled) [30, 31]

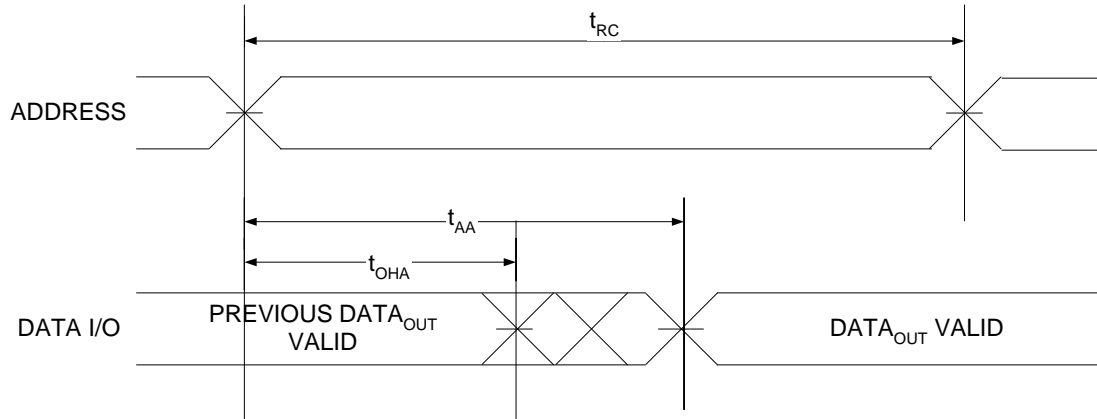
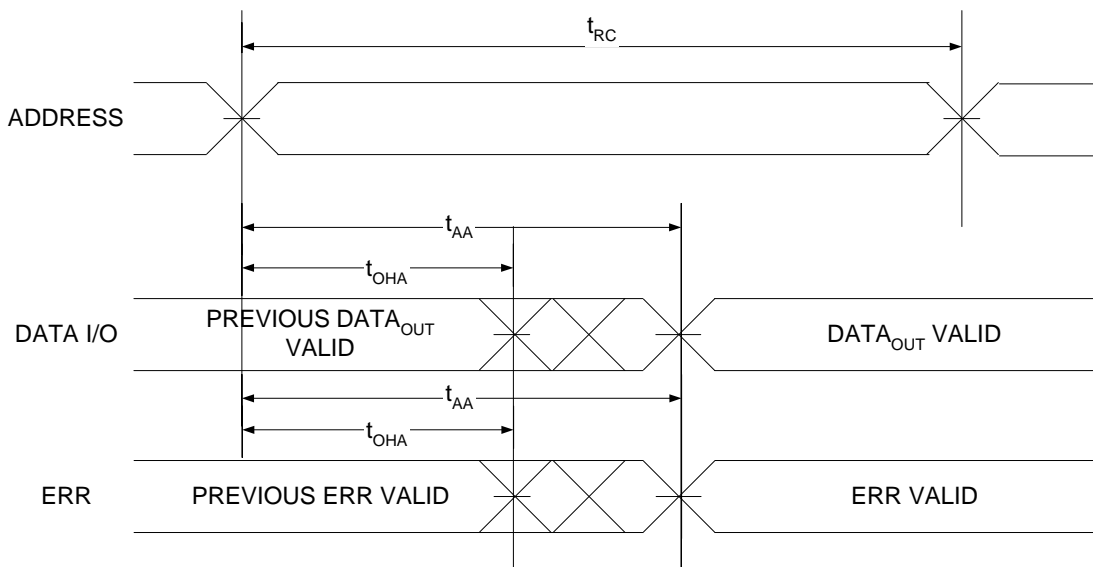

Figure 10. Read Cycle No. 2 of CY7S1061GE (Address Transition Controlled) [30, 31]



Notes

- 30. The device is continuously selected. $\overline{OE} = V_{IL}$, $\overline{CE} = V_{IL}$, \overline{BHE} or \overline{BLE} or both = V_{IL} .
- 31. \overline{WE} is HIGH for read cycle.

Switching Waveforms (continued)

Figure 11. Read Cycle No. 3 (OE Controlled) [32, 33, 34]

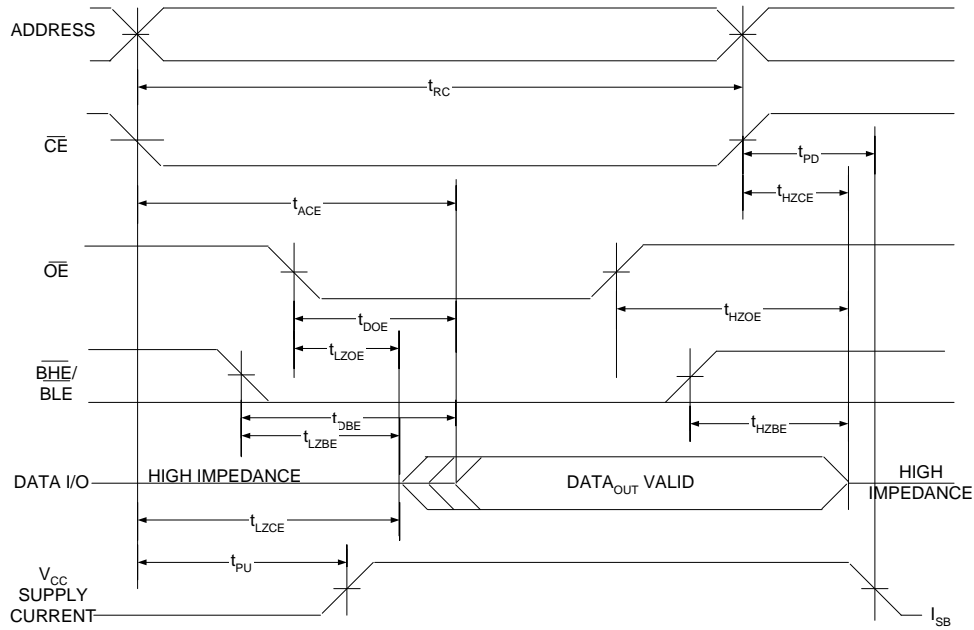
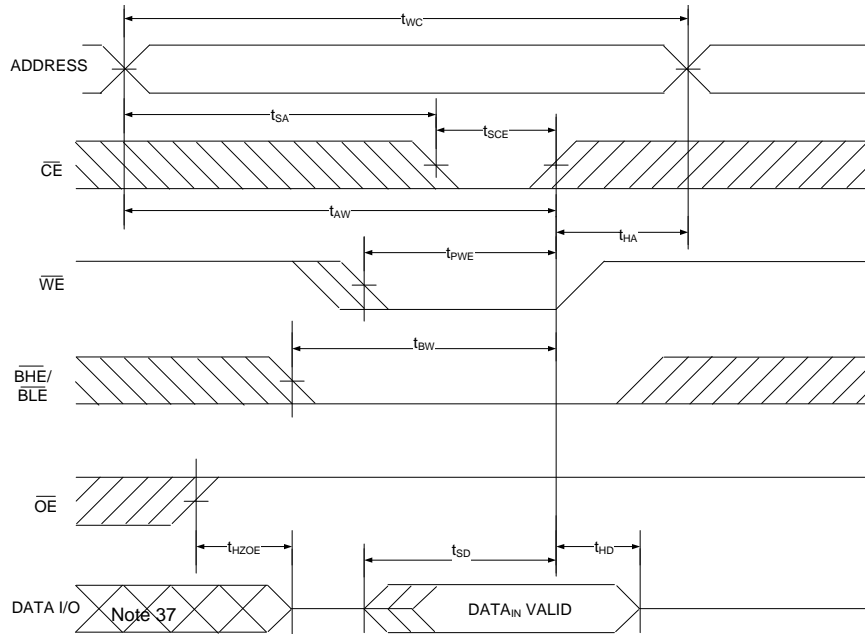

Figure 12. Write Cycle No. 1 (CE Controlled) [33, 35, 36]



Notes

- 32. \overline{WE} is HIGH for read cycle.
- 33. For all dual chip enable devices, \overline{CE} is the logical combination of \overline{CE}_1 and CE_2 . When \overline{CE}_1 is LOW and CE_2 is HIGH, \overline{CE} is LOW; when \overline{CE}_1 is HIGH or CE_2 is LOW, \overline{CE} is HIGH.
- 34. Address valid prior to or coincident with \overline{CE} LOW transition.
- 35. The internal write time of the memory is defined by the overlap of $\overline{WE} = V_{IL}$, $\overline{CE} = V_{IL}$ and \overline{BHE} or $\overline{BLE} = V_{IL}$. These signals must be LOW to initiate a write, and the HIGH transition of any of these signals can terminate the operation. The input data setup and hold timing should be referenced to the edge of the signal that terminates the write.
- 36. Data I/O is in high-impedance state if $\overline{CE} = V_{IH}$, or $\overline{OE} = V_{IH}$ or \overline{BHE} , and/or $\overline{BLE} = V_{IH}$.
- 37. During this period, the I/Os are in output state. Do not apply input signals.

Switching Waveforms (continued)

Figure 15. Write Cycle No. 3 ($\overline{\text{BLE}}$ or $\overline{\text{BHE}}$ Controlled) [43, 44, 45]

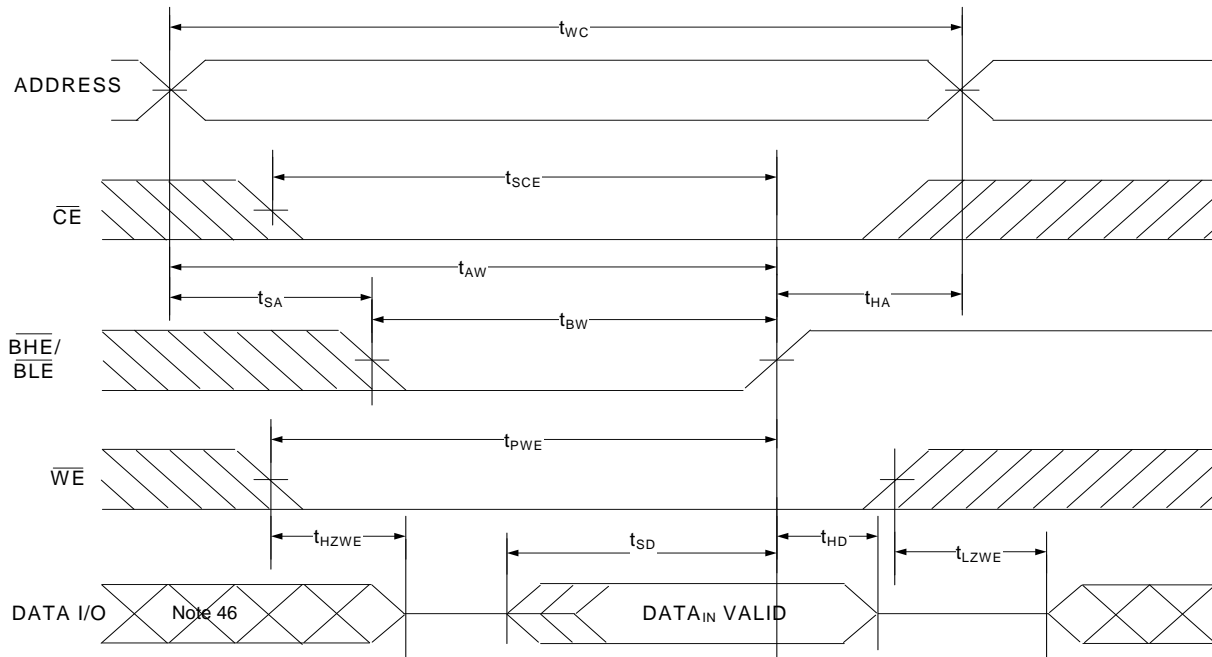

Notes

- 43. For all dual chip enable devices, $\overline{\text{CE}}$ is the logical combination of $\overline{\text{CE}}_1$ and CE_2 . When $\overline{\text{CE}}_1$ is LOW and CE_2 is HIGH, $\overline{\text{CE}}$ is LOW; when $\overline{\text{CE}}_1$ is HIGH or CE_2 is LOW, $\overline{\text{CE}}$ is HIGH.
- 44. The internal write time of the memory is defined by the overlap of $\overline{\text{WE}} = V_{\text{IL}}$, $\overline{\text{CE}} = V_{\text{IL}}$ and $\overline{\text{BHE}}$ or $\overline{\text{BLE}} = V_{\text{IL}}$. These signals must be LOW to initiate a write, and the HIGH transition of any of these signals can terminate the operation. The input data setup and hold timing should be referenced to the edge of the signal that terminates the write.
- 45. Data I/O is in high-impedance state if $\overline{\text{CE}} = V_{\text{IH}}$, or $\overline{\text{OE}} = V_{\text{IH}}$, or $\overline{\text{BHE}}$, and/or $\overline{\text{BLE}} = V_{\text{IH}}$.
- 46. During this period, the I/Os are in output state. Do not apply input signals.

Truth Table

\overline{DS}	\overline{CE}	\overline{OE}	\overline{WE}	\overline{BLE}	\overline{BHE}	I/O ₀ -I/O ₇	I/O ₈ -I/O ₁₅	Mode	Power
H	H	X ^[47]	X ^[47]	X ^[47]	X ^[47]	High-Z	High-Z	Standby	Standby (I _{SB})
H	L	L	H	L	L	Data out	Data out	Read all bits	Active (I _{CC})
H	L	L	H	L	H	Data out	High-Z	Read lower bits only	Active (I _{CC})
H	L	L	H	H	L	High-Z	Data out	Read upper bits only	Active (I _{CC})
H	L	X	L	L	L	Data in	Data in	Write all bits	Active (I _{CC})
H	L	X	L	L	H	Data in	High-Z	Write lower bits only	Active (I _{CC})
H	L	X	L	H	L	High-Z	Data in	Write upper bits only	Active (I _{CC})
H	L	H	H	X	X	High-Z	High-Z	Selected, outputs disabled	Active (I _{CC})
L ^[48]	H	X	X	X	X	High-Z	High-Z	Deep Sleep	Deep-Sleep Ultra Low Power (I _{DS})
L	L	X	X	X	X	–	–	Invalid mode ^[49]	–
H	L	X	X	H	H	High-Z	High-Z	Selected, outputs disabled	Active (I _{CC})

ERR Output – CY7S1061GE

Output ^[50]	Mode
0	Read operation, no single-bit error in the stored data.
1	Read operation, single-bit error detected and corrected.
High-Z	Device deselected or outputs disabled or Write operation

Notes

47. The input voltage levels on these pins should be either at V_{IH} or V_{IL}.

48. V_{IL} on \overline{DS} must be ≤ 0.2 V.

49. This mode does not guarantee data retention. Power cycling needs to be performed for the device to return to normal operation.

50. ERR is an Output pin. If not used, this pin should be left floating.

Ordering Information

Speed (ns)	Voltage Range	Ordering Code	Package Diagram	Package Type All (Pb-free)	ERR Pin/Ball	Operating Range
15	1.65 V–2.2 V	CY7S1061G18-15ZSXI	51-85160	54-pin TSOP II	No	Industrial
		CY7S1061G18-15ZSXIT				
10	2.2 V–3.6 V	CY7S1061G30-10ZSXI	51-85160	54-pin TSOP II	No	
		CY7S1061G30-10ZSXIT				
		CY7S1061G30-10BVXI	51-85150	48-ball VFBGA	No	
		CY7S1061G30-10BVXIT				
		CY7S1061GE30-10BVXI			Yes	
		CY7S1061GE30-10BVXIT				
	CY7S1061G30-10ZXI	51-85183	48-pin TSOP I	No		
	CY7S1061G30-10ZXIT					
	CY7S1061GE30-10ZXI			Yes		
	CY7S1061GE30-10ZXIT					
4.5 V–5.5 V	CY7S1061GE-10ZXI	51-85183	48-pin TSOP I	Yes		
	CY7S1061GE-10ZXIT					

Ordering Code Definitions

CY 7 S 1 06 1 G E 30 - 10 XX X I X

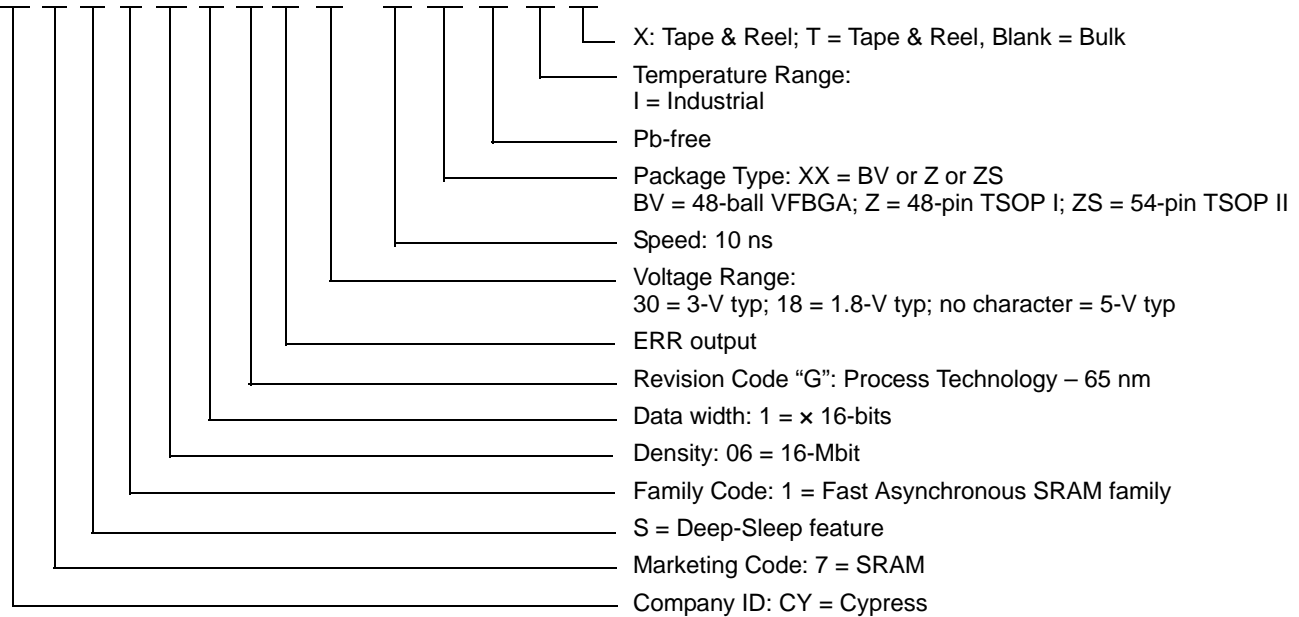

Package Diagrams

Figure 16. 48-ball VFBGA (6 x 8 x 1.0 mm) BV48/BZ48 Package Outline

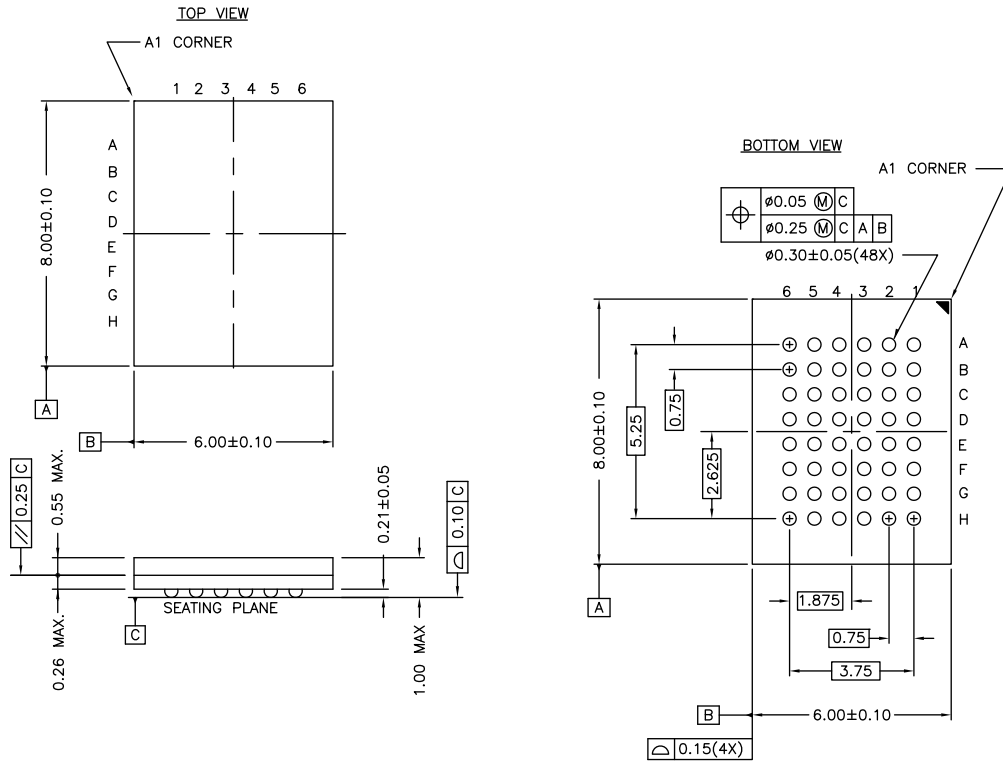

NOTE:
 PACKAGE WEIGHT: See Cypress Package Material Declaration Datasheet (PMDD)
 posted on the Cypress web.

51-85150 *H

Package Diagrams (continued)

Figure 17. 48-pin TSOP I (12 x 18.4 x 1.0 mm) Z48A Package Outline

DIMENSIONS IN INCHES[MM] MIN.
MAX.
JEDEC # MO-142

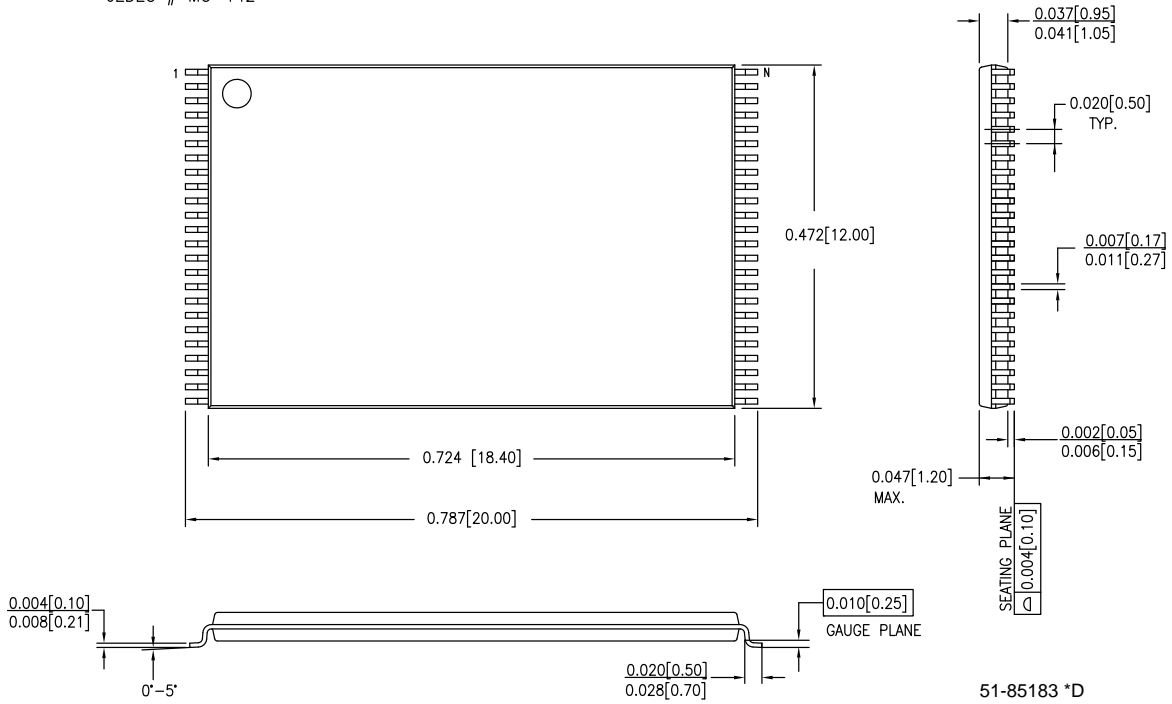

Package Diagrams (continued)

Figure 18. 54-pin TSOP II (22.4 x 11.84 x 1.0 mm) Z54-II Package Outline

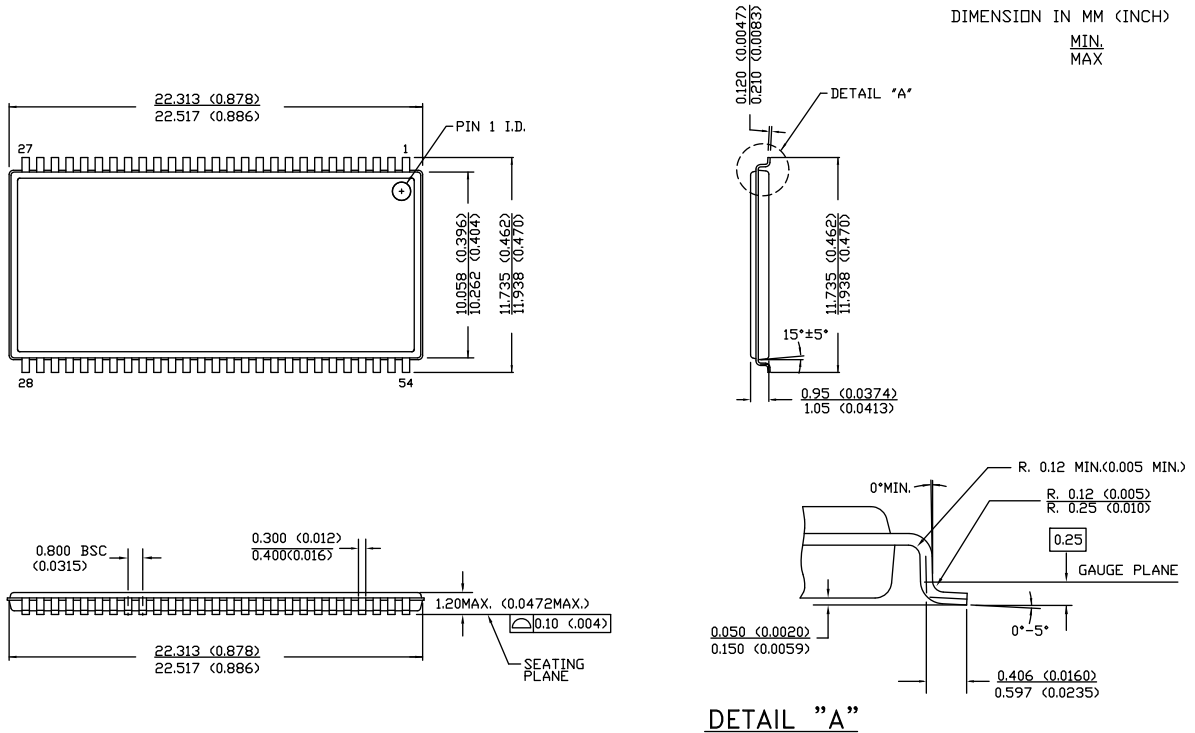

51-85160 *E

Acronyms

Acronym	Description
$\overline{\text{BHE}}$	Byte High Enable
$\overline{\text{BLE}}$	Byte Low Enable
$\overline{\text{CE}}$	Chip Enable
CMOS	Complementary Metal Oxide Semiconductor
I/O	Input/output
$\overline{\text{OE}}$	Output Enable
SRAM	Static random access memory
TTL	Transistor-transistor logic
VFBGA	Very fine-pitch ball grid array
$\overline{\text{WE}}$	Write Enable

Document Conventions

Units of Measure

Symbol	Unit of Measure
°C	degree Celsius
MHz	megahertz
μA	microampere
μs	microsecond
mA	milliampere
mm	millimeter
ns	nanosecond
Ω	ohm
%	percent
pF	picofarad
V	volt
W	watt

Document History Page

Document Title: CY7S1061G/CY7S1061GE, 16-Mbit (1 M words x 16 bit) Static RAM with PowerSnooze™ and ECC				
Document Number: 001-79707				
Rev.	ECN No.	Orig. of Change	Submission Date	Description of Change
*M	4791835	NILE	06/10/2015	Changed datasheet status to Final
*N	5436633	VINI	09/15/2016	Updated DC Electrical Characteristics : Updated VOH values for the voltage range V _{CC} = 2.7V to 3.6V. Updated Note 7 . Updated Ordering Code Definitions : Added Tape and Reel parts. Updated Copyright and Disclaimer.

Sales, Solutions, and Legal Information

Worldwide Sales and Design Support

Cypress maintains a worldwide network of offices, solution centers, manufacturer's representatives, and distributors. To find the office closest to you, visit us at [Cypress Locations](#).

Products

ARM® Cortex® Microcontrollers	cypress.com/arm
Automotive	cypress.com/automotive
Clocks & Buffers	cypress.com/clocks
Interface	cypress.com/interface
Internet of Things	cypress.com/iot
Lighting & Power Control	cypress.com/powerpsoc
Memory	cypress.com/memory
PSoC	cypress.com/psoc
Touch Sensing	cypress.com/touch
USB Controllers	cypress.com/usb
Wireless/RF	cypress.com/wireless

PSoC® Solutions

[PSoC 1](#) | [PSoC 3](#) | [PSoC 4](#) | [PSoC 5LP](#)

Cypress Developer Community

[Forums](#) | [Projects](#) | [Video](#) | [Blogs](#) | [Training](#) | [Components](#)

Technical Support

cypress.com/support

© Cypress Semiconductor Corporation, 2012-2016. This document is the property of Cypress Semiconductor Corporation and its subsidiaries, including Spansion LLC ("Cypress"). This document, including any software or firmware included or referenced in this document ("Software"), is owned by Cypress under the intellectual property laws and treaties of the United States and other countries worldwide. Cypress reserves all rights under such laws and treaties and does not, except as specifically stated in this paragraph, grant any license under its patents, copyrights, trademarks, or other intellectual property rights. If the Software is not accompanied by a license agreement and you do not otherwise have a written agreement with Cypress governing the use of the Software, then Cypress hereby grants you a personal, non-exclusive, nontransferable license (without the right to sublicense) (1) under its copyright rights in the Software (a) for Software provided in source code form, to modify and reproduce the Software solely for use with Cypress hardware products, only internally within your organization, and (b) to distribute the Software in binary code form externally to end users (either directly or indirectly through resellers and distributors), solely for use on Cypress hardware product units, and (2) under those claims of Cypress's patents that are infringed by the Software (as provided by Cypress, unmodified) to make, use, distribute, and import the Software solely for use with Cypress hardware products. Any other use, reproduction, modification, translation, or compilation of the Software is prohibited.

TO THE EXTENT PERMITTED BY APPLICABLE LAW, CYPRESS MAKES NO WARRANTY OF ANY KIND, EXPRESS OR IMPLIED, WITH REGARD TO THIS DOCUMENT OR ANY SOFTWARE OR ACCOMPANYING HARDWARE, INCLUDING, BUT NOT LIMITED TO, THE IMPLIED WARRANTIES OF MERCHANTABILITY AND FITNESS FOR A PARTICULAR PURPOSE. To the extent permitted by applicable law, Cypress reserves the right to make changes to this document without further notice. Cypress does not assume any liability arising out of the application or use of any product or circuit described in this document. Any information provided in this document, including any sample design information or programming code, is provided only for reference purposes. It is the responsibility of the user of this document to properly design, program, and test the functionality and safety of any application made of this information and any resulting product. Cypress products are not designed, intended, or authorized for use as critical components in systems designed or intended for the operation of weapons, weapons systems, nuclear installations, life-support devices or systems, other medical devices or systems (including resuscitation equipment and surgical implants), pollution control or hazardous substances management, or other uses where the failure of the device or system could cause personal injury, death, or property damage ("Unintended Uses"). A critical component is any component of a device or system whose failure to perform can be reasonably expected to cause the failure of the device or system, or to affect its safety or effectiveness. Cypress is not liable, in whole or in part, and you shall and hereby do release Cypress from any claim, damage, or other liability arising from or related to all Unintended Uses of Cypress products. You shall indemnify and hold Cypress harmless from and against all claims, costs, damages, and other liabilities, including claims for personal injury or death, arising from or related to any Unintended Uses of Cypress products.

Cypress, the Cypress logo, Spansion, the Spansion logo, and combinations thereof, WICED, PSoC, CapSense, EZ-USB, F-RAM, and Traveo are trademarks or registered trademarks of Cypress in the United States and other countries. For a more complete list of Cypress trademarks, visit cypress.com. Other names and brands may be claimed as property of their respective owners.

Looking for pricing, stock, or lifecycle information?

Click below to explore more details on WIN SOURCE:

 [View CY7S1061GE30-10BVXI on WIN SOURCE](#)

 [Infineon Technologies](#) Information

Optimize Your Supply Chain with WIN SOURCE Solutions

-  Global Sourcing Solution
-  Obsolete Management
-  Cost Control Management
-  Shortage Management
-  Alternative Solution
-  Excess Inventory Management