



**THE DATASHEET OF
CY91F465PAPMC-GS-UJE1**





Please note that Cypress is an Infineon Technologies Company.

The document following this cover page is marked as “Cypress” document as this is the company that originally developed the product. Please note that Infineon will continue to offer the product to new and existing customers as part of the Infineon product portfolio.

Continuity of document content

The fact that Infineon offers the following product as part of the Infineon product portfolio does not lead to any changes to this document. Future revisions will occur when appropriate, and any changes will be set out on the document history page.

Continuity of ordering part numbers

Infineon continues to support existing part numbers. Please continue to use the ordering part numbers listed in the datasheet for ordering.

CY91460P series is a line of general-purpose 32-bit RISC microcontrollers designed for embedded control applications which require high-speed real-time processing, such as consumer devices and on-board vehicle systems. This series uses the FR60 CPU, which is compatible with the FR family of CPUs.

This series contains the LIN-USART and CAN controllers.

Features

FR60 CPU core

- 32-bit RISC, load/store architecture, five-stage pipeline
- 16-bit fixed-length instructions (basic instructions)
- Instruction execution speed: 1 instruction per cycle
- Instructions including memory-to-memory transfer, bit manipulation, and barrel shift instructions: Instructions suitable for embedded applications
- Function entry/exit instructions and register data multi-load store instructions : Instructions supporting C language
- Register interlock function: Facilitating assembly-language coding
- Built-in multiplier with instruction-level support
 - Signed 32-bit multiplication: 5 cycles
 - Signed 16-bit multiplication: 3 cycles
- Interrupts (save PC/PS) : 6 cycles (16 priority levels)
- Harvard architecture enabling program access and data access to be performed simultaneously
- Instructions compatible with the FR family

Internal peripheral resources

- General-purpose ports : Maximum 141 ports
- DMAC (DMA Controller)
 - Maximum of 5 channels able to operate simultaneously
 - 2 transfer sources (internal peripheral/software)
 - Activation source can be selected using software
 - Addressing mode specifies full 32-bit addresses (increment/decrement/fixe)
 - Transfer mode (demand transfer/burst transfer/step transfer/block transfer)
 - Transfer data size selectable from 8/16/32-bit
 - Multi-byte transfer enabled (by software)
 - DMAC descriptor in I/O areas (200_H to 240_H, 1000_H to 1024_H)
- A/D converter (successive approximation type)
 - 10-bit resolution: maximum 41 channels *
 - Conversion time: minimum 1 μs
- External interrupt inputs : 16 channels *
 - 9 channels shared with CAN RX or I²C pins

- Bit search module (for REALOS)
 - Function to search the first bit position of "1", "0", "changed" from the MSB (most significant bit) within one word
- LIN-USART (full duplex double buffer): 12 channels, 4 channels with FIFO *
 - Clock synchronous/asynchronous selectable
 - Sync-break detection
 - Internal dedicated baud rate generator
- I²C bus interface (supports 400 kbps): 4 channels
 - Master/slave transmission and reception
 - Arbitration function, clock synchronization function
- CAN controller (C-CAN): up to 4 channels
 - Maximum transfer speed: 1 Mbps
 - 32 transmission/reception message buffers
- Sound generator : 1 channel
 - Tone frequency : PWM frequency divide-by-two (reload value + 1)
- 16-bit PPG timer : 32 channels *
- 16-bit PFM timer : 1 channel
- 16-bit reload timer: 16 channels
 - 8 reload timers can be used as up to 4 32-bit reload timers (by cascading 2 reload timers each).
- 16-bit free-run timer: 8 channels (1 channel each for ICU and OCU)
- Input capture: 8 channels (operates in conjunction with the free-run timer)
- Output compare: 8 channels (operates in conjunction with the free-run timer)
- Up/Down counter: 4 channels (4*8-bit or 2*16-bit) *
- Watchdog timer
- Real-time clock
- Low-power consumption modes : Sleep/stop mode function
- Low voltage detection circuit
- Clock supervisor
 - Monitors the sub-clock (32 kHz) and the main clock (4 MHz) , and switches to a recovery clock (CR oscillator, etc.) when the oscillations stop.

Note: * The maximum channel count is given; the real number depends on port multiplexing.

- Clock modulator
- Clock monitor
- Sub-clock calibration
 - Corrects the real-time clock timer when operating with the 32 kHz or CR oscillator
- Main oscillator stabilization timer
 - Generates an interrupt in sub-clock mode after the stabilization wait time has elapsed on the 23-bit stabilization wait time counter

- Sub-oscillator stabilization timer
 - Generates an interrupt in main clock mode after the stabilization wait time has elapsed on the 15-bit stabilization wait time counter

Package and technology

- Package : QFP-176
- CMOS 0.18 μm technology
- Power supply range 3 V to 5 V (1.8 V internal logic provided by a step-down voltage converter)
- Operating temperature range: between -40°C and $+125^{\circ}\text{C}$

Contents

Product Lineup	4	Block Diagram	67
Pin Assignment	7	CY91F465PA, CY91F467PA	67
CY91F465PA	7	CPU and Control Unit	68
CY91F467PA	8	Features	68
Pin Description	9	Internal architecture	68
CY91F465PA, CY91F467PA	9	Programming model	69
I/O Circuit Types	23	Registers	70
Port Multiplexing	29	Embedded Program/Data Memory (Flash)	73
PPMUX Register	29	Flash features	73
PPMUX2 Register (CY91F467PA)	29	Operation modes:	73
Multiplex Pinout CY91F465PA	30	Flash access in CPU mode	74
Multiplex Pinout CY91F467PA	31	Parallel Flash programming mode	78
Reload Timer / New Features	32	Poweron Sequence in parallel programming mode ..	79
Overview	32	Flash Security	80
Features	32	Notes About Flash Memory CRC Calculation	82
Registers	33	Embedded Data Flash (CY91F467PA)	83
Cascading Operation	35	Data Flash Features	83
Additional PPGs	36	Data Flash Block Diagram	83
Register	36	Data Flash Operation Modes	84
A/D Converter / New Features (CY91F467PA)	38	Data Flash access in CPU mode	85
A/D Converter Features	38	Data Flash Registers	88
Analog Input Connections	38	Data Flash Interrupts and DMA Access	94
A/D Converter / Range Comparator (CY91F467PA)	40	Data Flash parallel programming mode	95
Overview of A/D Converter and		Data Flash Security	97
A/D Range Comparator	40	Memory Space	101
A/D Converter Input Impedance	41	Memory Maps	102
Block Diagram of A/D Converter	42	CY91F465PA, CY91F467PA	102
Registers of the A/D Converter	43	I/O Map	103
Range Comparator	53	CY91F465PA, CY91F467PA	103
Operation of A/D Converter	60	Flash Memory, Data Flash and External Bus Area ..	138
ADC Interrupt Generation and DMA Access	63	Data Flash memory sector organisation	140
Handling Devices	64	Interrupt Vector Table	141
Preventing Latch-up	64	Recommended Settings	146
Handling of unused input pins	64	PLL and Clockgear settings	146
Power supply pins	64	Clock Modulator settings	147
Crystal oscillator circuit	64	Electrical Characteristics	152
Notes on using external clock	64	Absolute maximum ratings	152
Mode pins (MD_x)	65	Recommended operating conditions	155
Notes on operating in PLL clock mode	65	DC characteristics	156
Pull-up control	65	A/D converter characteristics	160
Notes on Debugger	66	FLASH memory program/erase characteristics	164
Execution of the RETI Command	66	AC characteristics	166
Break function	66	Ordering Information	188
Operand break	66	Package Dimension	189
Notes on PS register	66	Revision History	190
		Major Changes	191
		Document History	192

1. Product Lineup

Feature	Emulation Devices		CY91F465PA	CY91F467PA
	CY91V460A	CY91FV460B		
Max. core frequency (CLKB)	80 MHz	100 MHz	100 MHz	100 MHz
Max. resource frequency (CLKP)	40 MHz	50 MHz	50 MHz	50 MHz
Max. external bus frequency (CLKT)	40 MHz	50 MHz	50 MHz	50 MHz
Max. CAN frequency (CLKCAN)	20 MHz	50 MHz	50 MHz	50 MHz
Max. FlexRay frequency (SCLK)	-	-	-	-
Technology	0.35µm	0.18µm	0.18µm	0.18µm
Watchdog timer	yes	yes	yes	yes
Watchdog timer (RC osc. based)	yes (disengageable)	yes	yes	yes
Bit Search	yes	yes	yes	yes
Reset input (INITX)	yes	yes	yes	yes
Hardware standby input (HSTX)	yes	no	no	no
Clock Modulator	yes	yes	yes	yes
Clock Monitor	yes	yes	yes	yes
Low Power Mode	yes	yes	yes	yes
DMA	5 ch	5 ch	5 ch	5 ch
MMU/MPU	MPU (16 ch) ^{*1}	MPU (16 ch) ^{*1}	MPU (8 ch) ^{*1}	MPU (8 ch) ^{*1}
Flash memory	Emulation SRAM 32bit read data	Internal Flash memory 2112KB + external emulation SRAM with 64bit read data	544 KByte	1088 KByte
Satellite Flash memory	-	Data Flash 64 KByte	-	Data Flash 64 KByte
Flash Protection	-	yes	yes	yes
D-RAM	64 KByte	64 KByte	24 KByte	48 KByte
ID-RAM	64 KByte	64 KByte	16 KByte	32 KByte
Flash-Cache (Instruction cache)	16 KByte	16 KByte	8 KByte	8 KByte
Boot-ROM / BI-ROM	4 KByte fixed	16 KByte Boot Flash	4 KByte	4 KByte
RTC	1 ch	1 ch	1 ch	1 ch
Free Running Timer	8 ch	12 ch	8 ch ^{*2}	8 ch ^{*2}
ICU	8 ch	10 ch	8 ch ^{*2}	8 ch ^{*2}
OCU	8 ch	8 ch	8 ch ^{*2}	8 ch ^{*2}
Reload Timer	8 ch	16 ch	16 ch	16 ch
PPG 16-bit	16 ch	32 ch	32 ch ^{*2}	32 ch ^{*2}
PFM 16-bit	1 ch	1 ch	1 ch	1 ch
Sound Generator	1 ch	1 ch	1 ch	1 ch

Feature	Emulation Devices		CY91F465PA	CY91F467PA
	CY91V460A	CY91FV460B		
Up/Down Counter (8/16 bit)	4 ch (8-bit) / 2 ch (16-bit)	4 ch (8-bit) / 2 ch (16-bit)	4 ch (8-bit) / 2 ch (16-bit)* ²	4 ch (8-bit) / 2 ch (16-bit)* ²
C_CAN	6 ch (128msg)	6 ch (128msg)	3 ch (32msg)	4 ch (32msg)
LIN-USART	4 ch + 4 ch FIFO + 8 ch	16 ch FIFO	8 ch + 4 ch FIFO* ²	8 ch + 4 ch FIFO* ² (2 more pin relocations)
I ² C (400K)	4 ch	8 ch	4 ch* ²	4 ch* ²
FR external bus	yes (32bit addr, 32bit data)	yes (32bit addr, 32bit data)	yes (24bit addr, 16bit data)	yes (24bit addr, 16bit data)
External Interrupts	16 ch	16 ch	16 ch* ²	16 ch* ²
NMI Interrupts	1 ch	1 ch	1 ch	1 ch
General I/O ports	288	328 (24 non-multiplexed)	141	141
SMC	6 ch	328 (24 non-multiplexed)	-	-
LCD controller (40x4)	1 ch	1 ch	-	-
ADC (10-bit)	32 ch	32 ch + 22 ch (2 ADC macros)	32 ch* ²	32 ch * ² + 9 ch (2 ADC macros)
Alarm Comparator	2 ch	2 ch	-	-
Supply Supervisor (low voltage detection)	yes	yes	yes	yes
Clock Supervisor	yes	yes	yes	yes
Main clock oscillator	4 MHz	4 MHz	4 MHz	4 MHz
Sub clock oscillator	32kHz	32kHz	32kHz	32kHz
RC oscillator	100kHz	100kHz / 2MHz	100kHz / 2MHz	100kHz / 2MHz
PLL	x 20	x 25	x 25	x 25
DSU4	yes	yes	no	no
EDSU	yes (32 BP)* ¹	yes (32 BP)* ¹	yes (16 BP)* ¹	yes (16 BP)* ¹
Supply voltage	3V/5V	3V/5V	3V/5V	3V/5V
Regulator	yes	yes	yes	yes
Power consumption	n.a.	n.a.	< 1.4 W	< 1.4 W
Temperature Range (Ta)	0..70 C	0..70 C	-40..125 C	-40..125 C

Feature	Emulation Devices		CY91F465PA	CY91F467PA
	CY91V460A	CY91FV460B		
Package	BGA660	BGA896	LQFP-176	LQFP-176
Power on to PLL run	< 20 ms	< 20 ms	< 20 ms	< 20 ms
Flash Download Time	n.a.	< 8 sec. typical	< 5 sec. typical	< 6 sec. typical

*1: MPU channels use EDSU breakpoint registers (shared operation between MPU and EDSU).

*2: Maximum channel count is shown; function is multiplexed with external bus addresses.

2. Pin Assignment

2.1 CY91F465PA

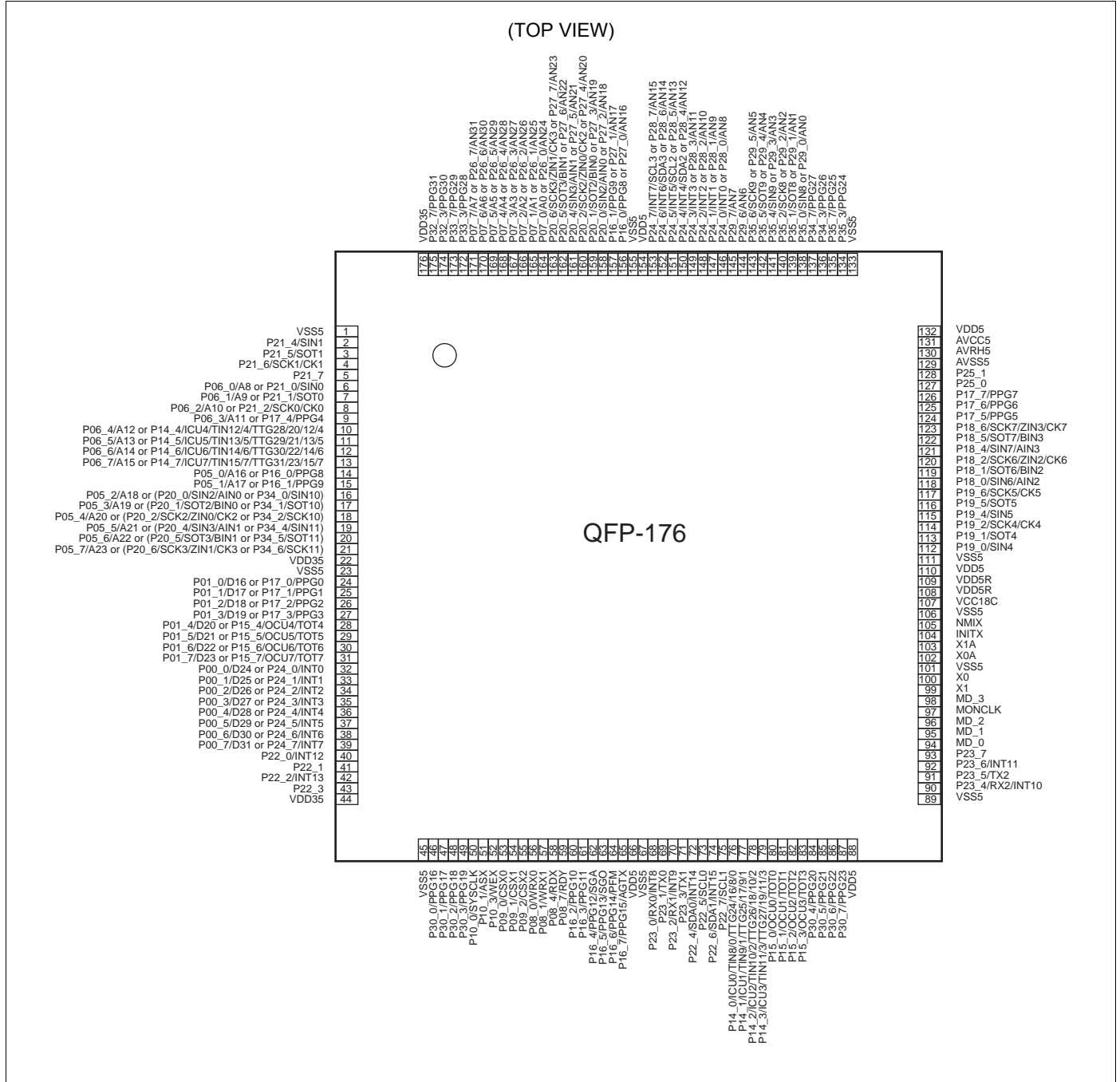

2.2 CY91F467PA

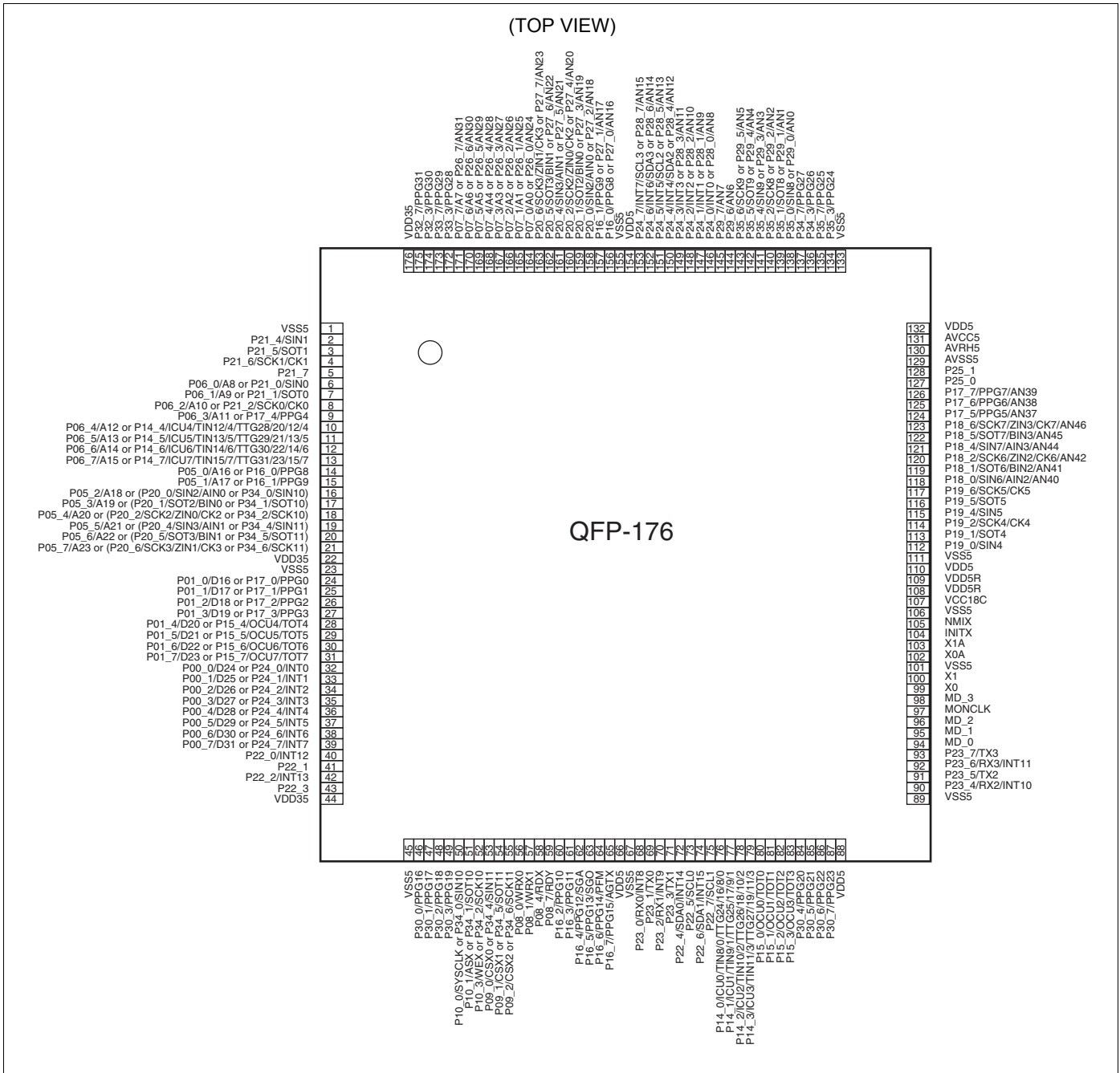

The pinout of CY91F467PA differs versus CY91F465PA at the following pins:

- Pins 50-55: Added re-located LIN-USART10/11
- Pins 92-93: Added CAN3 RX3, TX3
- Pins 118-126: Added ADC channels AN37-42, AN44-46
- Pins 99-100: X0/X1 are mirrored

3. Pin Description

3.1 CY91F465PA, CY91F467PA

Pin no.	Pin name	I/O	I/O circuit type*1	Mux	Function	
2	P21_4	I/O	A	—	General-purpose input/output port	
	SIN1				Data input pin of USART1	
3	P21_5	I/O	A	—	General-purpose input/output port	
	SOT1				Data output pin of USART1	
4	P21_6	I/O	A	—	General-purpose input/output port	
	SCK1				Clock input/output pin of USART1	
	CK1				External clock input pin of free-run timer 1	
5	P21_7	I/O	A	—	General-purpose input/output port	
6	P06_0	I/O	A	PPMUX.PS4=0	General-purpose input/output port	
	A8				Signal pin of external address bus (bit8)	
	OR					
	P21_0	I/O	A	PPMUX.PS4=1	General-purpose input/output port	
SIN0	Data input pin of USART0					
7	P06_1	I/O	A	PPMUX.PS4=0	General-purpose input/output port	
	A9				Signal pin of external address bus (bit9)	
	OR					
	P21_1	I/O	A	PPMUX.PS4=1	General-purpose input/output port	
SOT0	Data output pin of USART0					
8	P06_2	I/O	A	PPMUX.PS4=0	General-purpose input/output port	
	A10				Signal pin of external address bus (bit10)	
	OR					
	P21_2	I/O	A	PPMUX.PS4=1	General-purpose input/output port	
SCK0	Clock input/output pin of USART0					
CK0	External clock input pin of free-run timer 0					
9	P06_3	I/O	A	PPMUX.PS4=0	General-purpose input/output port	
	A11				Signal pin of external address bus (bit11)	
	OR					
	P17_4	I/O	A	PPMUX.PS4=1	General-purpose input/output port	
PPG4	Output pin of PPG timer					

Pin no.	Pin name	I/O	I/O circuit type*1	Mux	Function	
10 to 13	P06_4 to P06_7	I/O	A	PPMUX.PS4=0	General-purpose input/output ports	
	A12 to A15				Signal pins of external address bus (bit12 to bit15)	
	OR					
	P14_4 to P14_7	I/O	A	PPMUX.PS4=1	General-purpose input/output ports	
	ICU4 to ICU7				Input capture input pins	
	TIN12/4 to TIN15/7				External trigger input pins of reload timer	
	TTG28/20/12/4 to TTG31/23/15/7				External trigger input pins of PPG timer	
14	P05_0	I/O	A	PPMUX.PR10=0	General-purpose input/output port	
	A16				Signal pin of external address bus (bit16 to bit17)	
	OR					
	P16_0	I/O	A	PPMUX.PR10=1	General-purpose input/output port	
	PPG8				Output pin of PPG timer	
15	P05_1	I/O	A	PPMUX.PR11=0	General-purpose input/output port	
	A17				Signal pin of external address bus (bit16 to bit17)	
	OR					
	P16_1	I/O	A	PPMUX.PR11=1	General-purpose input/output port	
	PPG9				Output pin of PPG timer	
16	P05_2	I/O	A	PPMUX.PR12=0	General-purpose input/output port	
	A18				Signal pin of external address bus (bit18)	
	OR					
	P20_0	I/O	A	PPMUX.PR12=1 and PPMUX.PRPS0=1	General-purpose input/output port	
	SIN2				Data input pin of USART2	
	AIN0				Up/down counter input pin	
	OR					
P34_0	I/O	A	PPMUX.PR12=1 and PPMUX.PRPS0=0	General-purpose input/output port		
SIN10				Data input pin of USART10		
17	P05_3	I/O	A	PPMUX.PR13=0	General-purpose input/output port	
	A19				Signal pin of external address bus (bit19)	
	OR					
	P20_1	I/O	A	PPMUX.PR13=1 and PPMUX.PRPS0=1	General-purpose input/output port	
	SOT2				Data output pin of USART2	
	BIN0				Up/down counter input pin	
	OR					
P34_1	I/O	A	PPMUX.PR13=1 and PPMUX.PRPS0=0	General-purpose input/output port		
SOT10				Data output pin of USART10		

Pin no.	Pin name	I/O	I/O circuit type*1	Mux	Function	
18	P05_4	I/O	A	PPMUX.PR14=0	General-purpose input/output port	
	A20				Signal pin of external address bus (bit20)	
	OR					
	P20_2	I/O	A	PPMUX.PR14=1 and PPMUX.PRPS0=1	General-purpose input/output port	
	SCK2				Clock input/output pin of USART2	
	ZIN0				Up/down counter input pin	
	CK2				External clock input pin of free-run timer 2	
	OR					
	P34_2	I/O	A	PPMUX.PR14=1 and PPMUX.PRPS0=0	General-purpose input/output port	
	SCK10				Clock input/output pin of USART10	
19	P05_5	I/O	A	PPMUX.PR15=0	General-purpose input/output port	
	A21				Signal pin of external address bus (bit21)	
	OR					
	P20_4	I/O	A	PPMUX.PR15=1 and PPMUX.PRPS0=1	General-purpose input/output port	
	SIN3				Data input pin of USART3	
	AIN1				Up/down counter input pin	
	OR					
	P34_4	I/O	A	PPMUX.PR15=1 and PPMUX.PRPS0=0	General-purpose input/output port	
	SIN11				Data input pin of USART11	
	20	P05_6	I/O	A	PPMUX.PR16=0	General-purpose input/output port
A22		Signal pin of external address bus (bit22)				
OR						
P20_5		I/O	A	PPMUX.PR16=1 and PPMUX.PRPS0=1	General-purpose input/output port	
SOT3					Data output pin of USART3	
BIN1					Up/down counter input pin	
OR						
P34_5		I/O	A	PPMUX.PR16=1 and PPMUX.PRPS0=0	General-purpose input/output port	
SOT11					Data output pin of USART11	
21		P05_7	I/O	A	PPMUX.PR17=0	General-purpose input/output port
	A23	Signal pin of external address bus (bit23)				
	OR					
	P20_6	I/O	A	PPMUX.PR17=1 and PPMUX.PRPS0=1	General-purpose input/output port	
	SCK3				Clock input/output pin of USART3	
	ZIN1				Up/down counter input pin	
	CK3				External clock input pin of free-run timer 3	
	OR					
	P34_6	I/O	A	PPMUX.PR17=1 and PPMUX.PRPS0=0	General-purpose input/output port	
	SCK11				Clock input/output pin of USART11	

Pin no.	Pin name	I/O	I/O circuit type*1	Mux	Function	
24 to 27	P01_0 to P01_3	I/O	A	PPMUX.PS3=0	General-purpose input/output ports	
	D16 to D19				Signal pins of external data bus (bit16 to bit19)	
	OR					
	P17_0 to P17_3	I/O	A	PPMUX.PS3=1	General-purpose input/output ports	
PPG0 to PPG3	Output pins of PPG timer					
28 to 31	P01_4 to P01_7	I/O	A	PPMUX.PS3=0	General-purpose input/output ports	
	D20 to D23				Signal pins of external data bus (bit20 to bit23)	
	OR					
	P15_4 to P15_7	I/O	A	PPMUX.PS3=1	General-purpose input/output ports	
	OCU4 to OCU7				Output compare output pins	
TOT4 to TOT7	Reload timer output pins					
32 to 39	P00_0 to P00_7	I/O	A	PPMUX.PR0=0	General-purpose input/output ports	
	D24 to D31				Signal pins of external data bus (bit24 to bit31)	
	OR					
	P24_0 to P24_7	I/O	A	PPMUX.PR0=1	General-purpose input/output ports	
INT0 to INT7	External interrupt input pins					
40	P22_0	I/O	A	—	General-purpose input/output port	
	INT12				External interrupt input pin	
41	P22_1	I/O	A	—	General-purpose input/output port	
42	P22_2	I/O	A	—	General-purpose input/output port	
	INT13				External interrupt input pin	
43	P22_3	I/O	A	—	General-purpose input/output port	
46 to 49	P30_0 to P30_3	I/O	A	—	General-purpose input/output ports	
	PPG16 to PPG19				Output pins of PPG timer	
50	P10_0	I/O	A	—	General-purpose input/output port	
	SYCLK				External bus clock output pin	
	OR (CY91F467PA only)					
	P34_0	I/O	A	PPMUX2.PR0=1	General-purpose input/output port	
SIN10	Data input pin of USART10					
51	P10_1	I/O	A	—	General-purpose input/output port	
	ASX				Address strobe output pin	
	OR (CY91F467PA only)					
	P34_1	I/O	A	PPMUX2.PR1=1	General-purpose input/output port	
SOT10	Data output pin of USART10					
52	P10_3	I/O	A	—	General-purpose input/output port	
	WEX				Write enable output pin	
	OR (CY91F467PA only)					
	P34_2	I/O	A	PPMUX2.PR2=1	General-purpose input/output port	
SCK10	Clock input/output pin of USART10					

Pin no.	Pin name	I/O	I/O circuit type*1	Mux	Function	
53	P09_0	I/O	A	—	General-purpose input/output port	
	CSX0				Chip select output pin	
	OR (CY91F467PA only)					
	P34_4	I/O	A	PPMUX2.PR3=1	General-purpose input/output port	
SIN11	Data input pin of USART11					
54	P09_1	I/O	A	—	General-purpose input/output port	
	CSX1				Chip select output pin	
	OR (CY91F467PA only)					
	P34_5	I/O	A	PPMUX2.PR4=1	General-purpose input/output port	
SOT11	Data output pin of USART11					
55	P09_2	I/O	A	—	General-purpose input/output port	
	CSX2				Chip select output pin	
	OR (CY91F467PA only)					
	P34_6	I/O	A	PPMUX2.PR5=1	General-purpose input/output port	
SCK11	Clock input/output pin of USART11					
56, 57	P08_0, P08_1	I/O	A	—	General-purpose input/output ports	
	WRX0, WRX1				External write strobe output pins	
58	P08_4	I/O	A	—	General-purpose input/output port	
	RDX				External read strobe output pin	
59	P08_7	I/O	A	—	General-purpose input/output port	
	RDY				External ready input pin	
60, 61	P16_2, P16_3	I/O	A	—	General-purpose input/output ports	
	PPG10, PPG11				Output pins of PPG timer	
62	P16_4	I/O	A	—	General-purpose input/output port	
	PPG12				Output pin of PPG timer	
	SGA				SGA output pin of sound generator	
63	P16_5	I/O	A	—	General-purpose input/output port	
	PPG13				Output pin of PPG timer	
	SGO				SGO output pin of sound generator	
64	P16_6	I/O	A	—	General-purpose input/output port	
	PPG14				Output pin of PPG timer	
	PFM				Pulse frequency modulator output pin	
65	P16_7	I/O	A	—	General-purpose input/output port	
	PPG15				Output pin of PPG timer	
	ATGX				A/D converter external trigger input pin	
68	P23_0	I/O	A	—	General-purpose input/output port	
	RX0				RX input pin of CAN0	
	INT8				External interrupt input pin	
69	P23_1	I/O	A	—	General-purpose input/output port	
	TX0				TX output pin of CAN0	

Pin no.	Pin name	I/O	I/O circuit type*1	Mux	Function
70	P23_2	I/O	A	—	General-purpose input/output port
	RX1				RX input pin of CAN1
	INT9				External interrupt input pin
71	P23_3	I/O	A	—	General-purpose input/output port
	TX1				TX output pin of CAN1
72	P22_4	I/O	C	—	General-purpose input/output port
	SDA0				I ² C bus DATA input/output pin (open drain)
	INT14				External interrupt input pin
73	P22_5	I/O	C	—	General-purpose input/output port
	SCL0				I ² C bus clock input/output pin (open drain)
74	P22_6	I/O	C	—	General-purpose input/output port
	SDA1				I ² C bus DATA input/output pin (open drain)
	INT15				External interrupt input pin
75	P22_7	I/O	C	—	General-purpose input/output port
	SCL1				I ² C bus clock input/output pin (open drain)
76 to 79	P14_0 to P14_3	I/O	A	—	General-purpose input/output ports
	ICU0 to ICU3				Input capture input pins
	TIN8/0 to TIN11/3				External trigger input pins of reload timer
	TTG24/16/8/0 to TTG27/19/11/3				External trigger input pins of PPG timer
80 to 83	P15_0 to P15_3	I/O	A	—	General-purpose input/output ports
	OCU0 to OCU3				Output compare output pins
	TOT0 to TOT3				Reload timer output pins
84 to 87	P30_4 to P30_7	I/O	A	—	General-purpose input/output ports
	PPG20 to PPG23				Output pins of PPG timer
90	P23_4	I/O	A	—	General-purpose input/output port
	RX2				RX input pin of CAN2
	INT10				External interrupt input pin
91	P23_5	I/O	A	—	General-purpose input/output port
	TX2				TX output pin of CAN2
92	P23_6	I/O	A	—	General-purpose input/output ports
	RX3				RX input pin of CAN3 *4
	INT11				External interrupt input pin
93	P23_7	I/O	A	—	General-purpose input/output port
	TX3				TX output pin of CAN3 *4
94	MD_0	I	G	—	Mode setting pin
95	MD_1	I	G	—	Mode setting pin
96	MD_2	I	G	—	Mode setting pin
97	MONCLK	O	M	—	Clock Monitor pin
98	MD_3	I	G	—	Fast clock input pin

Pin no.	Pin name	I/O	I/O circuit type*1	Mux	Function
99	X1	—	J1	—	Clock (oscillation) output, F465PA
	X0				Clock (oscillation) input, F467PA
100	X0	—	J1	—	Clock (oscillation) input, F465PA
	X1				Clock (oscillation) output, F467PA
102	X0A	—	J2	—	Sub clock (oscillation) input
103	X1A	—	J2	—	Sub clock (oscillation) output
104	INITX	I	H	—	External reset input pin
105	NMIX	I	H	—	Non-maskable interrupt input pin
112	P19_0	I/O	A	—	General-purpose input/output port
	SIN4				Data input pin of USART4
113	P19_1	I/O	A	—	General-purpose input/output port
	SOT4				Data output pin of USART4
114	P19_2	I/O	A	—	General-purpose input/output port
	SCK4				Clock input/output pin of USART4
	CK4				External clock input pin of free-run timer 4
115	P19_4	I/O	A	—	General-purpose input/output port
	SIN5				Data input pin of USART5
116	P19_5	I/O	A	—	General-purpose input/output port
	SOT5				Data output pin of USART5
117	P19_6	I/O	A	—	General-purpose input/output port
	SCK5				Clock input/output pin of USART5
	CK5				External clock input pin of free-run timer 5
118	P18_0	I/O	A or B *2	—	General-purpose input/output port
	SIN6				Data input pin of USART6
	AIN2				Up/down counter input pin
	AN40				Analog input pin of A/D converter 2 *3
119	P18_1	I/O	A or B *2	—	General-purpose input/output port
	SOT6				Data output pin of USART6
	BIN2				Up/down counter input pin
	AN41				Analog input pin of A/D converter 2 *3
120	P18_2	I/O	A or B *2	—	General-purpose input/output port
	SCK6				Clock input/output pin of USART6
	ZIN2				Up/down counter input pin
	CK6				External clock input pin of free-run timer 6
	AN42				Analog input pin of A/D converter 2 *3
121	P18_4	I/O	A or B *2	—	General-purpose input/output port
	SIN7				Data input pin of USART7
	AIN3				Up/down counter input pin
	AN44				Analog input pin of A/D converter 2 *3

Pin no.	Pin name	I/O	I/O circuit type*1	Mux	Function	
122	P18_5	I/O	A or B *2	—	General-purpose input/output port	
	SOT7				Data output pin of USART7	
	BIN3				Up/down counter input pin	
	AN45				Analog input pin of A/D converter 2 *3	
123	P18_6	I/O	A or B *2	—	General-purpose input/output port	
	SCK7				Clock input/output pin of USART7	
	ZIN3				Up/down counter input pin	
	CK7				External clock input pin of free-run timer 7	
	AN46				Analog input pin of A/D converter 2 *3	
124 to 126	P17_5 to P17_7	I/O	A or B *2	—	General-purpose input/output ports	
	PPG5 to PPG7				Output pin of PPG timer	
	AN37 to AN39				Analog input pins of A/D converter 2 *3	
127, 128	P25_0, P25_1	I/O	A	—	General-purpose input/output ports	
134	P35_3	I/O	A	—	General-purpose input/output port	
	PPG24				Output pin of PPG timer	
135	P35_7	I/O	A	—	General-purpose input/output port	
	PPG25				Output pin of PPG timer	
136	P34_3	I/O	A	—	General-purpose input/output port	
	PPG26				Output pin of PPG timer	
137	P34_7	I/O	A	—	General-purpose input/output port	
	PPG27				Output pin of PPG timer	
138	P35_0	I/O	B	PPMUX.PS5=0	General-purpose input/output port	
	SIN8				Data input pin of USART8	
	OR					
		P29_0	I/O	B	PPMUX.PS5=1	General-purpose input/output port
	AN0	Analog input pin of A/D converter				
139	P35_1	I/O	B	PPMUX.PS5=0	General-purpose input/output port	
	SOT8				Data output pin of USART8	
	OR					
		P29_1	I/O	B	PPMUX.PS5=1	General-purpose input/output port
	AN1	Analog input pin of A/D converter				
140	P35_2	I/O	B	PPMUX.PS5=0	General-purpose input/output port	
	SCK8				Clock input/output pin of USART8	
	OR					
		P29_2	I/O	B	PPMUX.PS5=1	General-purpose input/output port
	AN2	Analog input pin of A/D converter				

Pin no.	Pin name	I/O	I/O circuit type*1	Mux	Function	
141	P35_4	I/O	B	PPMUX.PS5=0	General-purpose input/output port	
	SIN9				Data input pin of USART9	
	OR					
	P29_3	I/O	B	PPMUX.PS5=1	General-purpose input/output port	
AN3	Analog input pin of A/D converter					
142	P35_5	I/O	B	PPMUX.PS5=0	General-purpose input/output port	
	SOT9				Data output pin of USART9	
	OR					
	P29_4	I/O	B	PPMUX.PS5=1	General-purpose input/output port	
AN4	Analog input pin of A/D converter					
143	P35_6	I/O	B	PPMUX.PS5=0	General-purpose input/output port	
	SCK9				Clock input/output pin of USART9	
	OR					
	P29_5	I/O	B	PPMUX.PS5=1	General-purpose input/output port	
AN5	Analog input pin of A/D converter					
144, 145	P29_6, P29_7	I/O	B	—	General-purpose input/output ports	
	AN6, AN7				Analog input pins of A/D converter	
146 to 149	P24_0 to P24_3	I/O	B	PPMUX.PS2=0 and PPMUX.PR0=0	General-purpose input/output ports	
	INT0 to INT3				External interrupt input pins	
	OR					
	P28_0 to P28_3	I/O	B	PPMUX.PS2=1 or PPMUX.PR0=1	General-purpose input/output ports	
AN8 to AN11	Analog input pins of A/D converter					
150	P24_4	I/O	D	PPMUX.PS2=0 and PPMUX.PR0=0	General-purpose input/output port	
	INT4				External interrupt input pin	
	SDA2	I/O	D		I ² C bus DATA input/output pin (open drain)	
	OR					
P28_4	I/O	D	PPMUX.PS2=1 or PPMUX.PR0=1	General-purpose input/output port		
AN12				Analog input pin of A/D converter		
151	P24_5	I/O	D	PPMUX.PS2=0 and PPMUX.PR0=0	General-purpose input/output port	
	INT5				External interrupt input pin	
	SCL2	I/O	D		I ² C bus clock input/output pin (open drain)	
	OR					
P28_5	I/O	D	PPMUX.PS2=1 or PPMUX.PR0=1	General-purpose input/output port		
AN13				Analog input pin of A/D converter		
152	P24_6	I/O	D	PPMUX.PS2=0 and PPMUX.PR0=0	General-purpose input/output port	
	INT6				External interrupt input pin	
	SDA3				I ² C bus DATA input/output pin (open drain)	
	OR					
P28_6	I/O	D	PPMUX.PS2=1 or PPMUX.PR0=1	General-purpose input/output port		
AN14				Analog input pin of A/D converter		

Pin no.	Pin name	I/O	I/O circuit type*1	Mux	Function	
153	P24_7	I/O	C	PPMUX.PS2=0 and PPMUX.PR0=0	General-purpose input/output port	
	INT7				External interrupt input pin	
	SCL3				I ² C bus clock input/output pin (open drain)	
	OR					
	P28_7	I/O	B	PPMUX.PS2=1 or PPMUX.PR0=1	General-purpose input/output port	
	AN15				Analog input pin of A/D converter	
156	P16_0	I/O	A	PPMUX.PS1=0 and PPMUX.PR10=0	General-purpose input/output port	
	PPG8				Output pin of PPG timer	
	OR					
	P27_0	I/O	A	PPMUX.PS1=1 or PPMUX.PR10=1	General-purpose input/output port	
	AN16				Analog input pin of A/D converter	
	157	P16_1	I/O	A	PPMUX.PS1=0 and PPMUX.PR11=0	General-purpose input/output port
PPG9		Output pin of PPG timer				
OR						
P27_1		I/O	A	PPMUX.PS1=1 or PPMUX.PR11=1	General-purpose input/output port	
AN17					Analog input pin of A/D converter	
158		P20_0	I/O	A	PPMUX.PS1=0 and_not (PPMUX.PR12=1 and PPMUX.PRPS0=1)	General-purpose input/output port
	SIN2	Data input pin of USART2				
	AIN0	Up/down counter input pin				
	OR					
	P27_2	I/O	A	PPMUX.PS1=1 or (PPMUX.PR12=1 and PPMUX.PRPS0=1)	General-purpose input/output port	
	AN18				Analog input pin of A/D converter	
159	P20_1	I/O	A	PPMUX.PS1=0 and_not (PPMUX.PR13=1 and PPMUX.PRPS0=1)	General-purpose input/output port	
	SOT2				Data output pin of USART2	
	BIN0				Up/down counter input pin	
	OR					
	P27_3	I/O	A	PPMUX.PS1=1 or (PPMUX.PR13=1 and PPMUX.PRPS0=1)	General-purpose input/output port	
	AN19				Analog input pin of A/D converter	

Pin no.	Pin name	I/O	I/O circuit type*1	Mux	Function	
160	P20_2	I/O	A	PPMUX.PS1=0 and_not (PPMUX.PR14=1 and PPMUX.PRPS0=1)	General-purpose input/output port	
	SCK2				Clock input/output pin of USART2	
	ZIN0				Up/down counter input pin	
	CK2				External clock input pin of free-run timer 2	
	OR					
	P27_4	I/O	A	PPMUX.PS1=1 or (PPMUX.PR14=1 and PPMUX.PRPS0=1)	General-purpose input/output port	
AN20	Analog input pin of A/D converter					
161	P20_4	I/O	A	PPMUX.PS1=0 and_not (PPMUX.PR15=1 and PPMUX.PRPS0=1)	General-purpose input/output port	
	SIN3				Data input pin of USART3	
	AIN1				Up/down counter input pin	
	OR					
	P27_5	I/O	A	PPMUX.PS1=1 or (PPMUX.PR15=1 and PPMUX.PRPS0=1)	General-purpose input/output port	
	AN21				Analog input pin of A/D converter	
162	P20_5	I/O	A	PPMUX.PS1=0 and_not (PPMUX.PR16=1 and PPMUX.PRPS0=1)	General-purpose input/output port	
	SOT3				Data output pin of USART3	
	BIN1				Up/down counter input pin	
	OR					
	P27_6	I/O	A	PPMUX.PS1=1 or (PPMUX.PR16=1 and PPMUX.PRPS0=1)	General-purpose input/output port	
	AN22				Analog input pin of A/D converter	
163	P20_6	I/O	A	PPMUX.PS1=0 and_not (PPMUX.PR17=1 and PPMUX.PRPS0=1)	General-purpose input/output port	
	SCK3				Clock input/output pin of USART3	
	ZIN1				Up/down counter input pin	
	CK3				External clock input pin of free-run timer 3	
	OR					
	P27_7	I/O	A	PPMUX.PS1=1 or (PPMUX.PR17=1 and PPMUX.PRPS0=1)	General-purpose input/output port	
AN23	Analog input pin of A/D converter					
164	P07_0	I/O	A	PPMUX.PS0=0	General-purpose input/output port	
	A0				Signal pin of external address bus (bit0)	
	OR					
	P26_0	I/O	A	PPMUX.PS0=1	General-purpose input/output port	
AN24	Analog input pin of A/D converter					

Pin no.	Pin name	I/O	I/O circuit type*1	Mux	Function	
165	P07_1	I/O	A	PPMUX.PS0=0	General-purpose input/output port	
	A1				Signal pin of external address bus (bit1)	
	OR					
	P26_1	I/O	A	PPMUX.PS0=1	General-purpose input/output port	
AN25	Analog input pin of A/D converter					
166	P07_2	I/O	A	PPMUX.PS0=0	General-purpose input/output port	
	A2				Signal pin of external address bus (bit2)	
	OR					
	P26_2	I/O	A	PPMUX.PS0=1	General-purpose input/output port	
AN26	Analog input pin of A/D converter					
167	P07_3	I/O	A	PPMUX.PS0=0	General-purpose input/output port	
	A3				Signal pin of external address bus (bit3)	
	OR					
	P26_3	I/O	A	PPMUX.PS0=1	General-purpose input/output port	
AN27	Analog input pin of A/D converter					
168	P07_4	I/O	A	PPMUX.PS0=0	General-purpose input/output port	
	A4				Signal pin of external address bus (bit4)	
	OR					
	P26_4	I/O	A	PPMUX.PS0=1	General-purpose input/output port	
AN28	Analog input pin of A/D converter					
169	P07_5	I/O	A	PPMUX.PS0=0	General-purpose input/output port	
	A5				Signal pin of external address bus (bit5)	
	OR					
	P26_5	I/O	A	PPMUX.PS0=1	General-purpose input/output port	
AN29	Analog input pin of A/D converter					
170	P07_6	I/O	A	PPMUX.PS0=0	General-purpose input/output port	
	A6				Signal pin of external address bus (bit6)	
	OR					
	P26_6	I/O	A	PPMUX.PS0=1	General-purpose input/output port	
AN30	Analog input pin of A/D converter					
171	P07_7	I/O	A	PPMUX.PS0=0	General-purpose input/output port	
	A7				Signal pin of external address bus (bit7)	
	OR					
	P26_7	I/O	A	PPMUX.PS0=1	General-purpose input/output port	
AN31	Analog input pin of A/D converter					
172	P33_3	I/O	A	—	General-purpose input/output port	
	PPG28				Output pin of PPG timer	
173	P33_7	I/O	A	—	General-purpose input/output port	
	PPG29				Output pin of PPG timer	

Pin no.	Pin name	I/O	I/O circuit type*1	Mux	Function
174	P32_3	I/O	A	—	General-purpose input/output port
	PPG30				Output pin of PPG timer
175	P32_7	I/O	A	—	General-purpose input/output port
	PPG31				Output pin of PPG timer

*1: For information about the I/O circuit type, refer to “4. I/O Circuit Types”.

*2: CY91F465PA has type A, CY91F467PA has type B

*3: A/D converter channels 37-42, 44-46 only available on CY91F467PA.

*4: CAN3 only available on CY91F467PA.

[Power supply/Ground pins]

Pin no.	Pin name	I/O	Function
1, 23, 45, 67, 89, 101, 106, 111, 133, 155	VSS5	Supply	Ground pins
66, 88, 110, 132, 154	VDD5		Power supply pins
108, 109	VDD5R		Power supply pins for internal regulator
129	AVSS5		Analog ground pin for A/D converter
131	AVCC5		Power supply pin for A/D converter
130	AVRH5		Reference power supply pin for A/D converter
107	VCC18C		Capacitor connection pin for internal regulator
22, 44, 176	VDD35		Power supply pins for external bus part of I/O ring

4. I/O Circuit Types

Type	Circuit	Remarks
A		<p>CMOS level output (programmable $I_{OL} = 5\text{mA}$, $I_{OH} = -5\text{mA}$ and $I_{OL} = 2\text{mA}$, $I_{OH} = -2\text{mA}$)</p> <p>2 different CMOS hysteresis inputs with input shutdown function Automotive input with input shutdown function TTL input with input shutdown function Programmable pull-up resistor: 50kΩ approx.</p>
B		<p>CMOS level output (programmable $I_{OL} = 5\text{mA}$, $I_{OH} = -5\text{mA}$ and $I_{OL} = 2\text{mA}$, $I_{OH} = -2\text{mA}$)</p> <p>2 different CMOS hysteresis inputs with input shutdown function Automotive input with input shutdown function TTL input with input shutdown function Programmable pull-up resistor: 50kΩ approx. Analog input</p>

Type	Circuit	Remarks
C	<p>pull-up control</p> <p>data line</p> <p>pull-down control</p> <p>R</p> <p>CMOS hysteresis type1</p> <p>CMOS hysteresis type2</p> <p>Automotive inputs</p> <p>TTL input</p> <p>standby control for input shutdown</p>	<p>CMOS level output ($I_{OL} = 3mA$, $I_{OH} = -3mA$)</p> <p>2 different CMOS hysteresis inputs with input shutdown function</p> <p>Automotive input with input shutdown function</p> <p>TTL input with input shutdown function</p> <p>Programmable pull-up resistor: 50kΩ approx.</p>
D	<p>pull-up control</p> <p>data line</p> <p>pull-down control</p> <p>R</p> <p>CMOS hysteresis type1</p> <p>CMOS hysteresis type2</p> <p>Automotive inputs</p> <p>TTL input</p> <p>standby control for input shutdown</p> <p>analog input</p>	<p>CMOS level output ($I_{OL} = 3mA$, $I_{OH} = -3mA$)</p> <p>2 different CMOS hysteresis inputs with input shutdown function</p> <p>Automotive input with input shutdown function</p> <p>TTL input with input shutdown function</p> <p>Programmable pull-up resistor: 50kΩ approx.</p> <p>Analog input</p>

Type	Circuit	Remarks
E	<p>pull-up control</p> <p>driver strength control</p> <p>data line</p> <p>pull-down control</p> <p>R</p> <p>CMOS hysteresis type1</p> <p>CMOS hysteresis type2</p> <p>Automotive inputs</p> <p>TTL input</p> <p>standby control for input shutdown</p>	<p>CMOS level output (programmable $I_{OL} = 5\text{mA}$, $I_{OH} = -5\text{mA}$ and $I_{OL} = 2\text{mA}$, $I_{OH} = -2\text{mA}$, and $I_{OL} = 30\text{mA}$, $I_{OH} = -30\text{mA}$)</p> <p>2 different CMOS hysteresis inputs with input shutdown function</p> <p>Automotive input with input shutdown function</p> <p>TTL input with input shutdown function</p> <p>Programmable pull-up resistor: 50kΩ approx.</p>
F	<p>pull-up control</p> <p>driver strength control</p> <p>data line</p> <p>pull-down control</p> <p>R</p> <p>CMOS hysteresis type1</p> <p>CMOS hysteresis type2</p> <p>Automotive inputs</p> <p>TTL input</p> <p>standby control for input shutdown</p> <p>analog input</p>	<p>CMOS level output (programmable $I_{OL} = 5\text{mA}$, $I_{OH} = -5\text{mA}$ and $I_{OL} = 2\text{mA}$, $I_{OH} = -2\text{mA}$, and $I_{OL} = 30\text{mA}$, $I_{OH} = -30\text{mA}$)</p> <p>2 different CMOS hysteresis inputs with input shutdown function</p> <p>Automotive input with input shutdown function</p> <p>TTL input with input shutdown function</p> <p>Programmable pull-up resistor: 50kΩ approx.</p> <p>Analog input</p>

Type	Circuit	Remarks
G		Mask ROM and EVA device: CMOS Hysteresis input pin Flash device: CMOS input pin 12 V withstand (for MD [2:0])
H		CMOS Hysteresis input pin Pull-up resistor value: 50 kΩ approx.
J1		High-speed oscillation circuit: <ul style="list-style-type: none"> • Programmable between oscillation mode (external crystal or resonator connected to X0/X1 pins) and Fast external Clock Input (FCI) mode (external clock connected to X0 pin) • Feedback resistor = approx. $2 * 0.5 \text{ M}\Omega$. Feedback resistor is grounded in the center when the oscillator is disabled or in FCI mode.
J2		Low-speed oscillation circuit: <ul style="list-style-type: none"> • Feedback resistor = approx. $2 * 5 \text{ M}\Omega$. Feedback resistor is grounded in the center when the oscillator is disabled.

Type	Circuit	Remarks
K	<p>pull-up control</p> <p>driver strength control</p> <p>data line</p> <p>pull-down control</p> <p>R</p> <p>CMOS hysteresis type1</p> <p>CMOS hysteresis type2</p> <p>Automotive inputs</p> <p>TTL input</p> <p>standby control for input shutdown</p> <p>LCD SEG/COM</p>	<p>CMOS level output (programmable $I_{OL} = 5\text{mA}$, $I_{OH} = -5\text{mA}$ and $I_{OL} = 2\text{mA}$, $I_{OH} = -2\text{mA}$)</p> <p>2 different CMOS hysteresis inputs with input shutdown function</p> <p>Automotive input with input shutdown function</p> <p>TTL input with input shutdown function</p> <p>Programmable pull-up resistor: 50kΩ approx.</p> <p>LCD SEG/COM output</p>
L	<p>pull-up control</p> <p>driver strength control</p> <p>data line</p> <p>pull-down control</p> <p>R</p> <p>CMOS hysteresis type1</p> <p>CMOS hysteresis type2</p> <p>Automotive inputs</p> <p>TTL input</p> <p>standby control for input shutdown</p> <p>VLCD</p>	<p>CMOS level output (programmable $I_{OL} = 5\text{mA}$, $I_{OH} = -5\text{mA}$ and $I_{OL} = 2\text{mA}$, $I_{OH} = -2\text{mA}$)</p> <p>2 different CMOS hysteresis inputs with input shutdown function</p> <p>Automotive input with input shutdown function)</p> <p>TTL input with input shutdown function</p> <p>Programmable pull-up resistor: 50kΩ approx.</p> <p>Analog input</p> <p>LCD Voltage input</p>

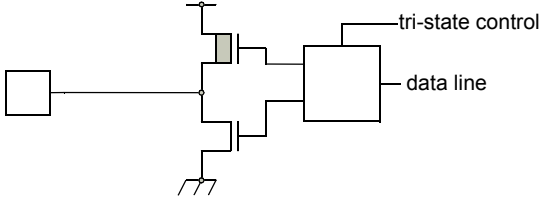
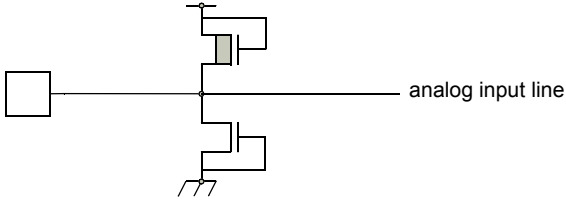
Type	Circuit	Remarks
M		<p>CMOS level tri-state output $(I_{OL} = 5\text{mA}, I_{OH} = -5\text{mA})$</p>
N		<p>Analog input pin with protection</p>

5. Port Multiplexing

5.1 PPMUX Register

CY91460P series uses port multiplexing. This means that there are more implemented resources than actual pins. Which ports/resources are multiplexed to which pin depends on the PPMUX register setting.

	15	14	13	12	11	10	9	8
0x049A	PR17	PR16	PR15	PR14	PR13	PR12	PR11	PR10

	7	6	5	4	3	2	1	0
0x049B	PRPS0	PR0	PS5	PS4	PS3	PS2	PS1	PS0

The PPMUX register can only be written as a half-word. It is writable only once.

The PPMUX register is reset by INIT or by a soft reset (the initial value is 0x0000 then).

Note: Port relocation (via PRx) always has higher priority than Port Switching (via PSx).

5.2 PPMUX2 Register (CY91F467PA)

CY91F467PA has a second port multiplexing register, PPMUX2, for multiplexing of LIN-USART10,11.

The settings of PPMUX2 have priority over the settings of PPMUX.

	15	14	13	12	11	10	9	8
0x049C	-	-	PR5	PR4	PR3	PR2	PR1	PR0

	7	6	5	4	3	2	1	0
0x049D	-	-	-	-	-	-	-	-

The PPMUX2 register can only be written as a half-word. It is writable only once.

The PPMUX2 register is reset by INIT or by a soft reset (the initial value is 0x00 then).

5.3 Multiplex Pinout CY91F465PA

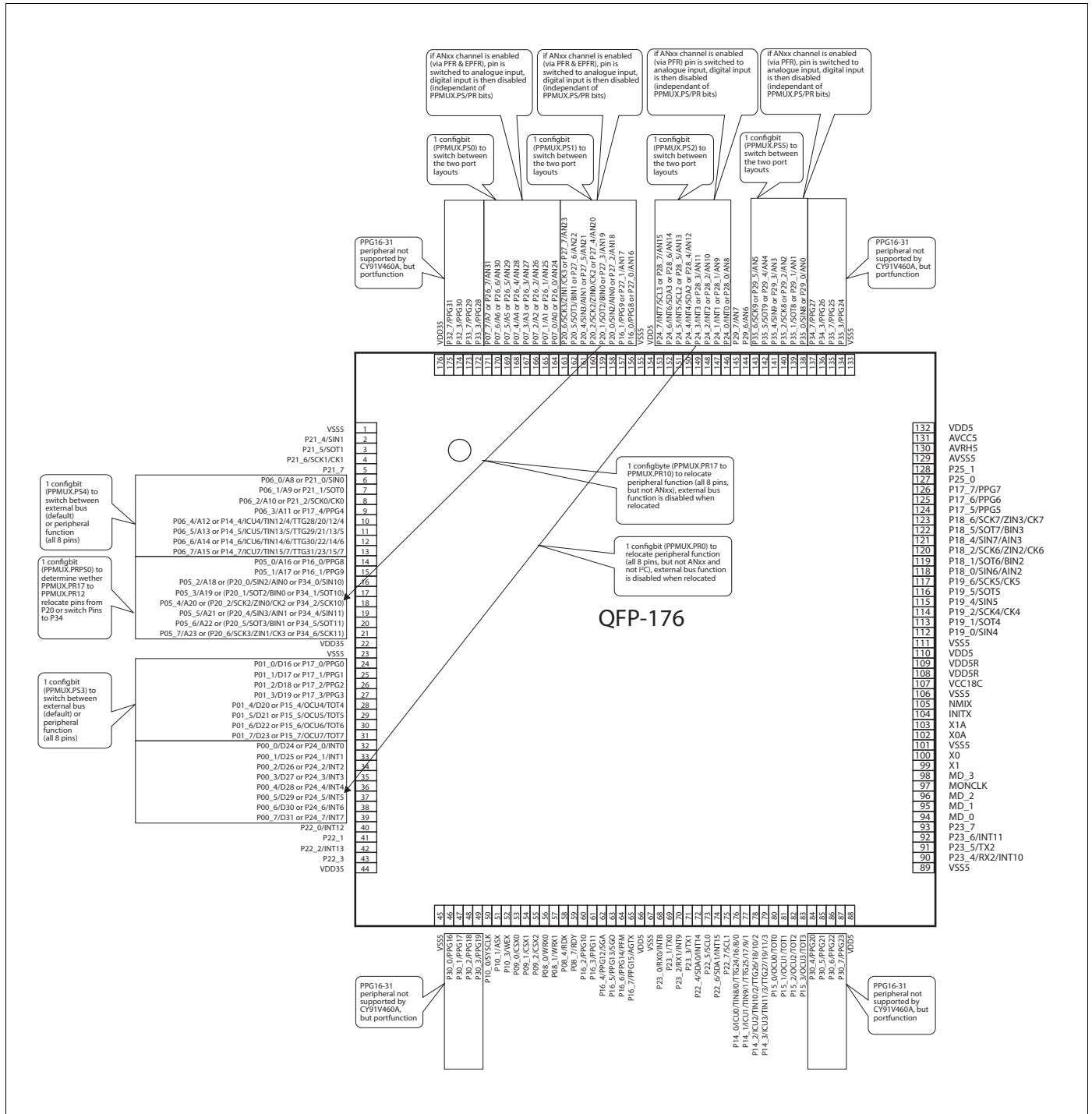

5.4 Multiplex Pinout CY91F467PA

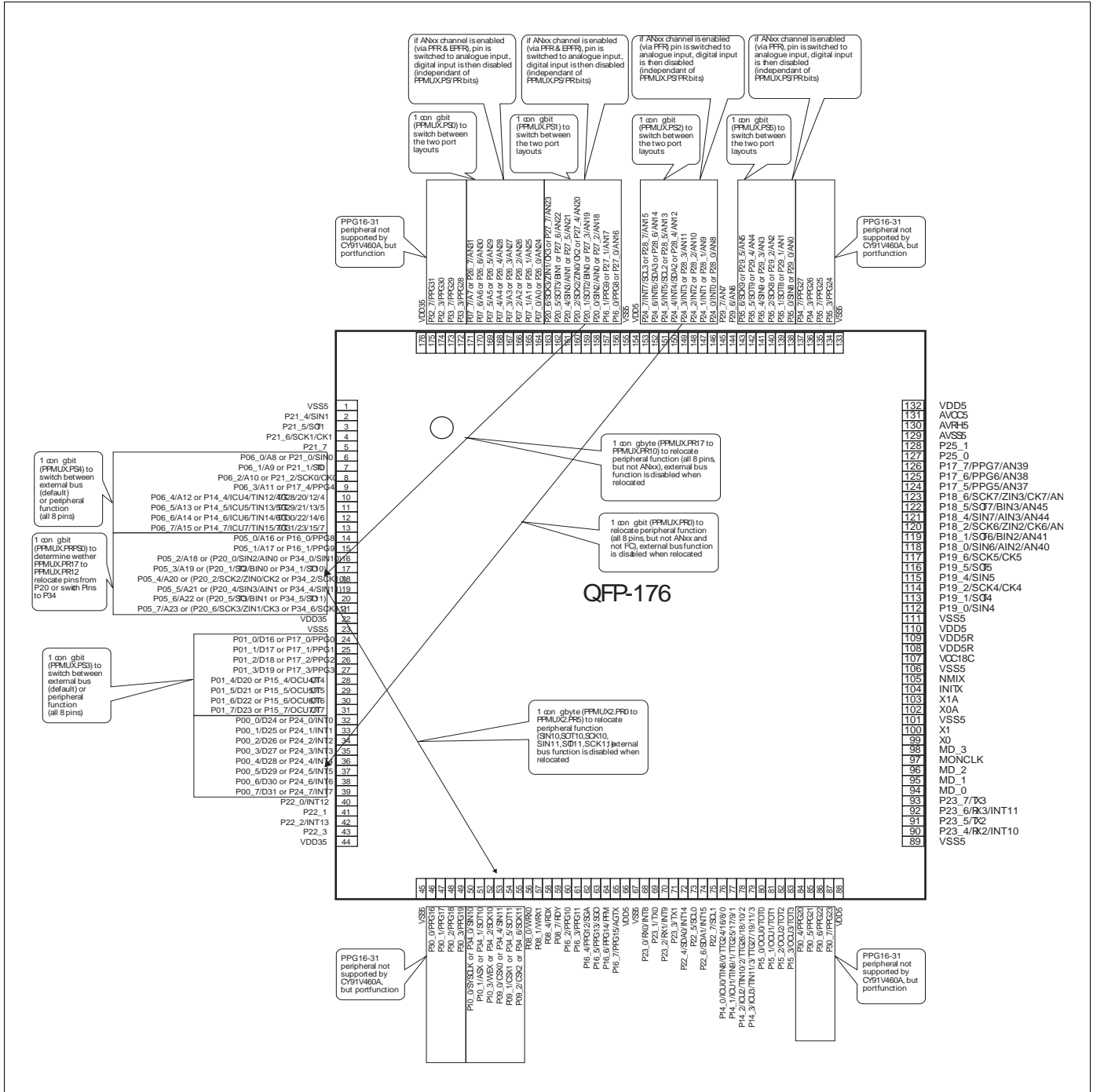

6. Reload Timer / New Features

6.1 Overview

The reload timer uses a 16 bit down counter to detect the input signal trigger and perform a count down.

The count length is 16 bits.

6.2 Features

Format: 16 bit down counter with reload register

Quantity: 16 (Output: 8 channels TOT[0 to 7])

Cascading clock mode: (only available for Reload timers 8,10,12,14)

- Count clock for Reload timer 8: Output of Reload timer 9
- Count clock for Reload timer 10: Output of Reload timer 11
- Count clock for Reload timer 12: Output of Reload timer 13
- Count clock for Reload timer 14: Output of Reload timer 15

Count active edge: When in external event mode, choose from 3 types.

- External trigger (rising /falling/both edges)
Interrupt: Request generated by underflow
Other 1: Counter stop in software/can be reopened
Other 2: Control of other peripheral functions possible
- PPG activation trigger source:
Reload timer 8 : PPG16, PPG17
Reload timer 9 : PPG18, PPG19
Reload timer 10 : PPG20, PPG21
Reload timer 11 : PPG22, PPG23
Reload timer 12 : PPG24, PPG25
Reload timer 13 : PPG26, PPG27
Reload timer 14 : PPG28, PPG29
Reload timer 15 : PPG30, PPG31
- A/D converter activation trigger source (Reload timer 7 : A/D)

6.3 Registers

6.3.1 TMCSR: Reload Timer Control Status Register

The control status register controls the operation mode of the reload timer and interrupts.

- TMCSR8 (Reload timer 8): Address: 00596H (Access: Byte, Half-word)
- TMCSR9 (Reload timer 9): Address: 0059EEH (Access: Byte, Half-word)
- TMCSR10 (Reload timer 10): Address: 005A6H (Access: Byte, Half-word)
- TMCSR11 (Reload timer 11): Address: 005AEH (Access: Byte, Half-word)
- TMCSR12 (Reload timer 12): Address: 005B6H (Access: Byte, Half-word)
- TMCSR13 (Reload timer 13): Address: 005BEH (Access: Byte, Half-word)
- TMCSR14 (Reload timer 14): Address: 005C6H (Access: Byte, Half-word)
- TMCSR15 (Reload timer 15): Address: 005CEH (Access: Byte, Half-word)

15	14	13	12	11	10	9	8	bit
			CSL2	CSL1	CSL0	MOD2	MOD1	
-	-	-	0	0	0	0	0	Initial Value
RX/WX	RX/WX	RX/WX	R/W	R/W	R/W	R/W0	R/W	Attribute
								Rewrite during operation

7	6	5	4	3	2	1	0	bit
MOD0		OULT	RELD	INTE	UF	CNTE	TRG	
0	-	0	0	0	0	0	0	Initial Value
R/W	RX/WX	R/W	R/W	R/W	R(RM1),W	R/W	R0/W	Attribute
					O	O	O	Rewrite during operation

(O: can be rewritten, x: cannot be rewritten)

bit12-10: Count clock selection

CLKP: peripheral clock

CSL2	CSL1	CSL0	Count clock	Remarks
0	0	0	Internal clock CLKP/2	
0	0	1	Internal clock CLKP/8	
0	1	0	Internal clock CLKP/32	
0	1	1	External event (external clock)	
1	0	1	Internal clock CLKP/64	
1	1	0	Internal clock CLKP/128	
1	1	1	RLT n+1 output	only allowed for RLT 8, 10, 12, 14

6.3.2 TMR: Timer Register

- TMR8 (Reload timer 8): Address: 0592H (Access: Half-word)
- TMR9 (Reload timer 9): Address: 059AH (Access: Half-word)
- TMR10 (Reload timer 10): Address: 05A2H (Access: Half-word)
- TMR11 (Reload timer 11): Address: 05AAH (Access: Half-word)
- TMR12 (Reload timer 12): Address: 05B2H (Access: Half-word)
- TMR13 (Reload timer 13): Address: 05BAH (Access: Half-word)
- TMR14 (Reload timer 14): Address: 05C2H (Access: Half-word)
- TMR15 (Reload timer 15): Address: 05CAH (Access: Half-word)

6.3.3 TMRC: Consistent Timer Register

- TMR89 (Reload timer 8, 9): Address: 05D0H (Access: Word)
- TMR1011 (Reload timer 10, 11): Address: 05D4H (Access: Word)
- TMR1213 (Reload timer 12, 13): Address: 05D8H (Access: Word)
- TMR1415 (Reload timer 14, 15): Address: 05DCH (Access: Word)

31	30	29	28	27	26	25	24	bit
D31	D30	D29	D28	D27	D26	D25	D24	
X	X	X	X	X	X	X	X	Initial Value
R/WX	R/WX	R/WX	R/WX	R/WX	R/WX	R/WX	R/WX	Attribute
23	22	21	20	19	18	17	16	bit
D23	D22	D21	D20	D19	D18	D17	D16	
X	X	X	X	X	X	X	X	Initial Value
R/WX	R/WX	R/WX	R/WX	R/WX	R/WX	R/WX	R/WX	Attribute
15	14	13	12	11	10	9	8	bit
D15	D14	D13	D12	D11	D10	D9	D8	
X	X	X	X	X	X	X	X	Initial Value
R/WX	R/WX	R/WX	R/WX	R/WX	R/WX	R/WX	R/WX	Attribute
7	6	5	4	3	2	1	0	bit
D7	D6	D5	D4	D3	D2	D1	D0	
X	X	X	X	X	X	X	X	Initial Value
R/WX	R/WX	R/WX	R/WX	R/WX	R/WX	R/WX	R/WX	Attribute

The count values of cascaded reload timers can be read out through the timer register TMRC at the same time. Upper halfword contain TMRn, lower halfword TMRn+1.
Please perform the read out using word access.

6.3.4 TMRLR: Reload register

- TMRLR8 (Reload timer 8): Address: 0590H (Access: Half-word)
- TMRLR9 (Reload timer 9): Address: 0598H (Access: Half-word)
- TMRLR10 (Reload timer 10): Address: 05A0H (Access: Half-word)
- TMRLR11 (Reload timer 11): Address: 05A8H (Access: Half-word)
- TMRLR12 (Reload timer 12): Address: 05B0H (Access: Half-word)
- TMRLR13 (Reload timer 13): Address: 05B8H (Access: Half-word)
- TMRLR14 (Reload timer 14): Address: 05C0H (Access: Half-word)
- TMRLR15 (Reload timer 15): Address: 05C8H (Access: Half-word)

6.4 Cascading Operation

In reload mode Reload timer 9 Output is set as Count event for Reload timer 8, both edge modes.

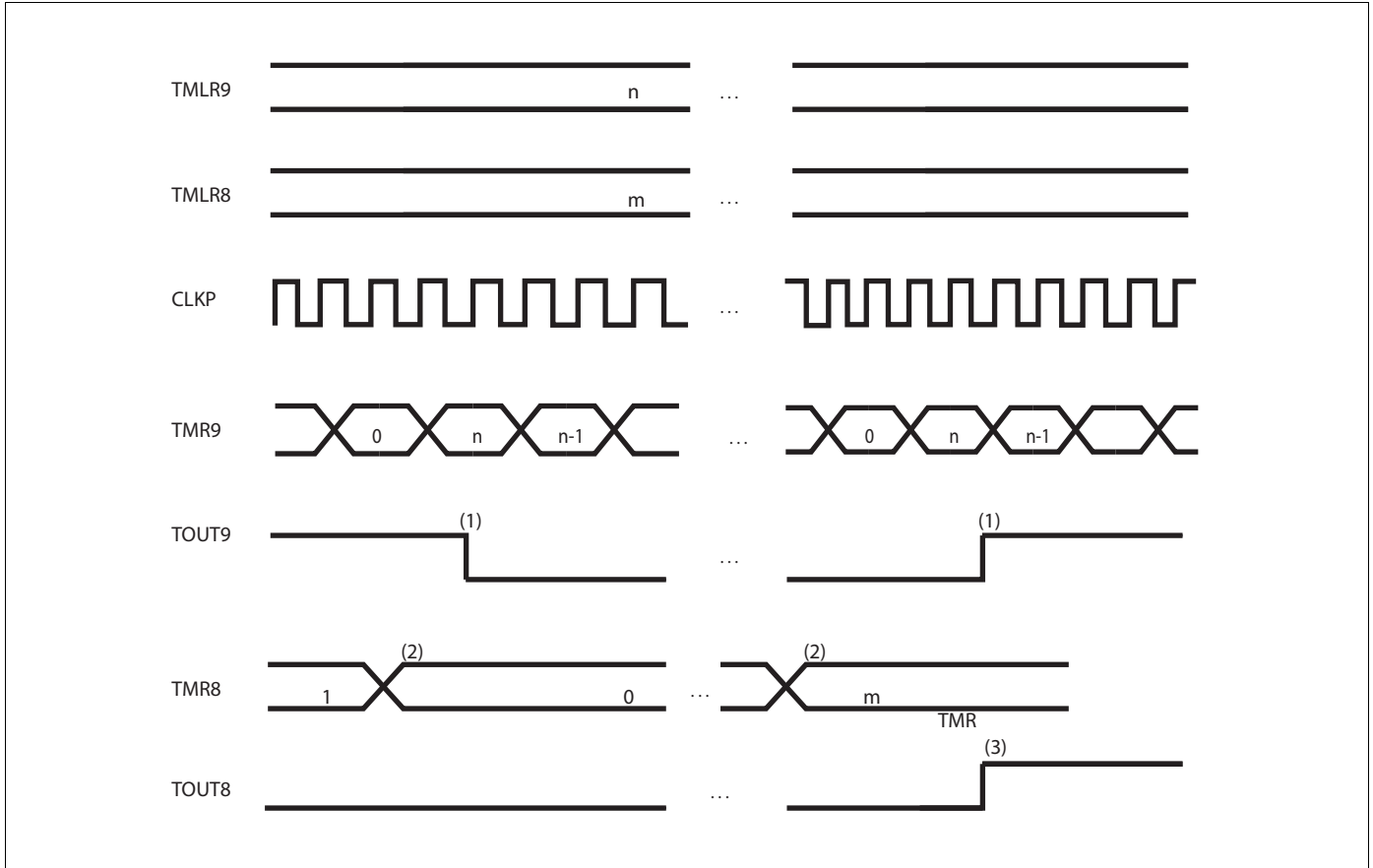

- (1) TOUT9 signal change caused by underflow TMR9
- (2) TMR8 decreased by TOUT9
- (3) TOUT8 signal change caused by underflow of TMR8

7. Additional PPGs

7.1 Register

7.1.1 PCSR: PPG Cycle Setting Register

Controls the cycle of the PPG.

- PCSR16 (PPG16): Address 0512h (Access: Half-word)
- PCSR17 (PPG17): Address 0518h (Access: Half-word)
- PCSR18 (PPG18): Address 0522h (Access: Half-word)
- PCSR19 (PPG19): Address 0528h (Access: Half-word)
- PCSR20 (PPG20): Address 0532h (Access: Half-word)
- PCSR21 (PPG21): Address 0538h (Access: Half-word)
- PCSR22 (PPG22): Address 0542h (Access: Half-word)
- PCSR23 (PPG23): Address 0548h (Access: Half-word)
- PCSR24 (PPG24): Address 0552h (Access: Half-word)
- PCSR25 (PPG25): Address 0558h (Access: Half-word)
- PCSR26 (PPG26): Address 0562h (Access: Half-word)
- PCSR27 (PPG27): Address 0568h (Access: Half-word)
- PCSR28 (PPG28): Address 0572h (Access: Half-word)
- PCSR29 (PPG29): Address 0578h (Access: Half-word)
- PCSR30 (PPG30): Address 0582h (Access: Half-word)
- PCSR31 (PPG31): Address 0588h (Access: Half-word)

7.1.2 PDUT: PPG Duty Setting Register

Sets the duty of the PPG output waveform.

- PDUT16 (PPG16): Address 0514h (Access: Half-word)
- PDUT17 (PPG17): Address 051Ch (Access: Half-word)
- PDUT18 (PPG18): Address 0524h (Access: Half-word)
- PDUT19 (PPG19): Address 052Ch (Access: Half-word)
- PDUT20 (PPG20): Address 0534h (Access: Half-word)
- PDUT21 (PPG21): Address 053Ch (Access: Half-word)
- PDUT22 (PPG22): Address 0544h (Access: Half-word)
- PDUT23 (PPG23): Address 054Ch (Access: Half-word)
- PDUT24 (PPG24): Address 0554h (Access: Half-word)
- PDUT25 (PPG25): Address 055Ch (Access: Half-word)
- PDUT26 (PPG26): Address 0564h (Access: Half-word)
- PDUT27 (PPG27): Address 056Ch (Access: Half-word)
- PDUT28 (PPG28): Address 0574h (Access: Half-word)
- PDUT29 (PPG29): Address 057Ch (Access: Half-word)
- PDUT30 (PPG30): Address 0584h (Access: Half-word)
- PDUT31 (PPG31): Address 058Ch (Access: Half-word)

7.1.3 PCN: PPG Control Status register

Controls the operations and status of PPGs.

- PCN16 (PPG16): Address 0516h (Access: Byte, Half-word)
- PCN17 (PPG17): Address 051Eh (Access: Byte, Half-word)
- PCN18 (PPG18): Address 0526h (Access: Byte, Half-word)
- PCN19 (PPG19): Address 052Eh (Access: Byte, Half-word)
- PCN20 (PPG20): Address 0536h (Access: Byte, Half-word)
- PCN21 (PPG21): Address 053Eh (Access: Byte, Half-word)
- PCN22 (PPG22): Address 0546h (Access: Byte, Half-word)
- PCN23 (PPG23): Address 054Eh (Access: Byte, Half-word)
- PCN24 (PPG24): Address 0556h (Access: Byte, Half-word)
- PCN25 (PPG25): Address 055Eh (Access: Byte, Half-word)
- PCN26 (PPG26): Address 0566h (Access: Byte, Half-word)
- PCN27 (PPG27): Address 056Eh (Access: Byte, Half-word)
- PCN28 (PPG28): Address 0576h (Access: Byte, Half-word)
- PCN29 (PPG29): Address 057Eh (Access: Byte, Half-word)
- PCN30 (PPG30): Address 0586h (Access: Byte, Half-word)
- PCN31 (PPG31): Address 058Eh (Access: Byte, Half-word)

7.1.4 GCN1: General Control register 1

Selects a trigger input to PPG0 PPG16-PPG19, PPG20-PPG23, PPG24-PPG27 and PPG28-PPG31.

- GCN14 (PPG16-PPG19): Address 0500h (Access: Half-word)
- GCN15 (PPG20-PPG23): Address 0504h (Access: Half-word)
- GCN16 (PPG24-PPG27): Address 0505h (Access: Half-word)
- GCN17 (PPG28-PPG31): Address 050Ch (Access: Half-word)

7.1.5 GCN2: General Control register 2

Generates PPG16-PPG19, PPG20-PPG23, PPG24-PPG27 and PPG28-PPG31 internal trigger levels using software.

- GCN24 (PPG16-PPG19): Address 0503h (Access: Byte)
- GCN25 (PPG20-PPG23): Address 0507h (Access: Byte)
- GCN26 (PPG24-PPG27): Address 050Bh (Access: Byte)
- GCN27 (PPG28-PPG31): Address 050Fh (Access: Byte)

7.1.6 PTMR: PPG Timer Register

Reads the counts of PPGs.

- PTMR16 (PPG16): Address 0510h (Access: Half-word)
- PTMR17 (PPG17): Address 0518h (Access: Half-word)
- PTMR18 (PPG18): Address 0520h (Access: Half-word)
- PTMR19 (PPG19): Address 0528h (Access: Half-word)
- PTMR20 (PPG20): Address 0530h (Access: Half-word)
- PTMR21 (PPG21): Address 0538h (Access: Half-word)
- PTMR22 (PPG22): Address 0540h (Access: Half-word)
- PTMR23 (PPG23): Address 0548h (Access: Half-word)
- PTMR24 (PPG24): Address 0550h (Access: Half-word)
- PTMR25 (PPG25): Address 0558h (Access: Half-word)
- PTMR26 (PPG26): Address 0560h (Access: Half-word)
- PTMR27 (PPG27): Address 0568h (Access: Half-word)
- PTMR28 (PPG28): Address 0570h (Access: Half-word)
- PTMR29 (PPG29): Address 0578h (Access: Half-word)
- PTMR30 (PPG30): Address 0581h (Access: Half-word)
- PTMR31 (PPG31): Address 0588h (Access: Half-word)

8. A/D Converter / New Features (CY91F467PA)

CY91F467PA has two 10-bit A/D Converter macros. The original ADC, which is available on all CY91460 series devices, is now called “ADC 0”, the second macro is called “ADC 1”.

8.1 A/D Converter Features

- Both ADC 0 and ADC 1 are 10-bit / 1 μ s macros used on other CY91460 series devices.
- Both ADCs have the new digital part with separated A/D Result registers and 4-channel Range Comparator, see chapter 9: “A/D Converter / Range Comparator (CY91F467PA)”.
- Both ADCs can be triggered from Reload Timer RLT7.
- Both ADCs can be triggered from the same external ATGX pin (GP16_7).
- On CY91F467PA, ADC0 and ADC1 share the same analog power and reference supply (AV_{CC5},AVRH5,AV_{SS}).

8.2 Analog Input Connections

8.2.1 Global ADC Analog Channel Enable

The global ADC channel enable feature makes the ADC analog inputs independent of PFR/EPFR settings. It was introduced for 2 reasons:

- Some new ADC channels are assigned to ports whose PFR/EPFR combinations are already used completely for other resources.
- Customers may measure digital output signals with the ADC to check for external shortages. PFR/EPFR settings for ADC always switch the digital port to HiZ mode.

The global ADC channel enable is controlled by bit ADCHE in PORTEN register:

PORTEN Register Address: 0x0498 Access: Byte

7	6	5	4	3	2	1	0	Bit
-	-	-	-	-	ADCHE	CPORTEN	GPORTEN	
X	X	X	X	X	0	0	0	Initial value
RX, W0	RX, W0	RX, W0	RX, W0	RX, W0	R, W	R, W	R, W	Attribute

Bit7-3: Reserved bits. Always write 0 to these bits.

Bit2: ADCHE Global A/D Channel Enable.

ADCHE	Function
0 [initial]	Global A/D Channel Enable is OFF. The ADC analog lines of channels 0-31 are enabled by setting of the ADC enable bits (ADEn) in the ADERH,ADERL register and PFR/EPFR. PFR/EPFR will set the digital output to HiZ mode and disable the digital input lines of the port.
1	Global A/D Channel Enable is ON. The ADC analog lines of channels 6-7 are enabled by setting of the ADC enable bits (ADEn) in the ADERH,ADERL register only. ADEn will disable the digital input lines of the port, but the digital outputs are not changed. For analog measurement, the user has to switch the port to input direction.

This bit is cleared by software reset (RST) and can be written and read by CPU.

Note: For new ADC channels (AN32 to AN53, device depending), the ADCHE feature is always ON.
For old ADC channels (AN0 to AN31), the ADCHE feature is always OFF if the channels are re-located to other pins. On CY91F467PA, the ADCHE feature is only available on the non-relocated ADC channels 6-7 on ports P29[6,7].

Bit1:0: CPORTEN,GPORTEN Global Port Input Enable

CPORTEN	GPORTEN	Function
0 [initial]	0 [initial]	All port input lines are disabled.
1	0	The Port Input for LIN-USART 4 is enabled. This functionality is used by the Boot ROM to establish a serial communication with Softune for flash programming.
X	1	All port input lines are enabled.

- These bits are cleared by software reset (RST) and can be written and read by CPU.
- After execution of the Boot ROM the bits are in initial state.

8.2.2 ADC 0 Analog Inputs

ADC 0 serves the analog inputs AN0 to AN31. There are 2 methods for enabling the analog inputs:

- For all channels: Set ADC channel enable bits (ADEn) in the ADERH,ADERL register and set PFR/EPFR of the attached I/O port
- For channels 6-7: Set ADC channel enable bits (ADEn) in the ADERH,ADERL register and set global ADC channel enable, see 8.2.1“Global ADC Analog Channel Enable”.

Note : To use the channels AN0 to AN5 and AN8 to AN31, port multiplexing must be set. See chapter 5.“Port Multiplexing” and chapter 3.“Pin Description” for details. The ADC channel enable feature ADCHE is not available on the re-located channels.

8.2.3 ADC 1 Analog Inputs

ADC 1 serves the analog inputs AN37 to AN42, AN44 to AN46.

The analog inputs are enabled just by setting the ADC channel enable bits ADEn in the AD1ERH, AD1ERL registers. The Global ADC Analog Channel Enable feature is fixed ON here.

9. A/D Converter / Range Comparator (CY91F467PA)

The new A/D Converter with Range Comparator is available on CY91FV460B and CY91F467PA and is backward compatible to the A/D converter used on older devices.

This chapter provides an overview of the A/D converter, describes the register structure and functions, and describes the operation of the A/D converter.

9.1 Overview of A/D Converter and A/D Range Comparator

The A/D converter converts analog input voltages into digital values and provides the following features. Any ADC channel can be assigned to one of 4 Range Comparators.

9.1.1 Features of the A/D converter:

- Conversion time: minimum 1 μ s per channel.
- RC type successive approximation conversion with sample & hold circuit
- 10-bit or 8-bit resolution
- Program section analog input from 32 channels
- 1 common result data register and 32 dedicated channel result data registers
- Single conversion mode: Convert the specified channel(s) only once.
- Continuous mode: Repeatedly convert the specified channels.
- Scan conversion mode: Continuous conversion of multiple channels, programmable for up to 32 channels
- Stop mode: Convert one channel, then temporarily halt until the next activation.
(Enables synchronization of the conversion start timing.)
- A/D conversion can be followed by an A/D conversion interrupt request to CPU. This interrupt, an option that is ideal for continuous processing can be used to start a DMA transfer of the results of A/D conversion to memory.
- A/D conversion of all enabled channels (scan conversion) can be followed by an A/D End of Scan interrupt request to CPU. The data is stored into dedicated channel result registers, which can be read out using DMA transfer.
- Conversion startup may be by software, external trigger (falling edge) or timer (rising edge).

9.1.2 Features of the A/D Range Comparator (RCO):

- 4 conversion result Range Comparator channels, comparing the upper 8 bit of the conversion result with an upper and a lower threshold. The thresholds are programmable for the 4 comparators independently.
- Any ADC channel can be assigned to one of the 4 range comparators.
- The comparison results will set “overflow” and “interrupt” flags per ADC channel, depending on the configuration. It is possible to configure the comparison for:
 - “out of range”: The flags are set if the A/D result is below the lower OR above the upper threshold.
 - “inside range”: The flags are set if the A/D result is above the lower AND below the upper threshold.
- The configuration can be set individually per ADC channel.
- Range comparison can be followed by an A/D Range Comparator interrupt request to CPU.

9.2 A/D Converter Input Impedance

The following figure shows the sampling circuit of the A/D converter:

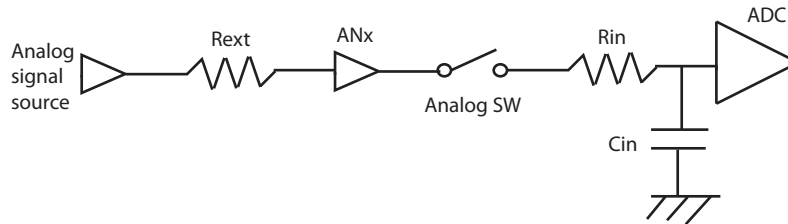

Do not set Rext over maximum sampling time (Tsamp).
 $R_{ext} = T_{smp} / (7 * C_{in}) - R_{in}$

9.3 Block Diagram of A/D Converter

The following figure shows block diagram of A/D converter.

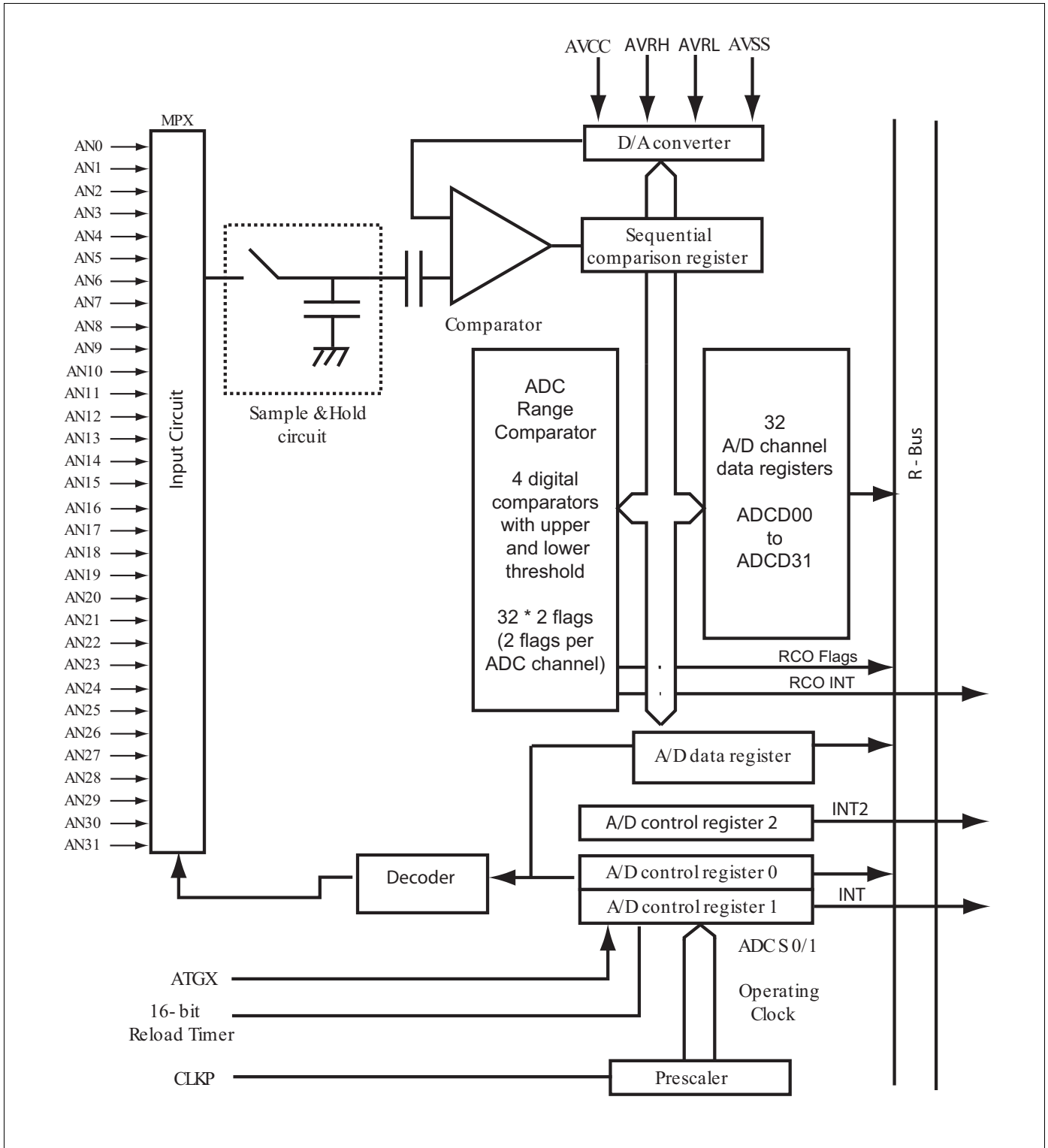

9.4 Registers of the A/D Converter

The A/D converter with Range Comparator has the following registers:

Address (ADC 0)	Address (ADC 1)	x=0 or 1 for ADC0, ADC1 respectively				Register
		+0	+1	+2	+3	
0001A0 _H	0005E0 _H	ADxERH		ADxERL		A/D channel Enable register
0001A4 _H	0005E4 _H	ADxCS1	ADxCS0	ADxCR1	ADxCR0	A/D Control / Status register 0 + 1, A/D Conversion Result register
0001A8 _H	0005E8 _H	ADxCT1	ADxCT0	ADxSCH	ADxECH	Sampling timer setting register, Start Channel setting register, End Channel setting register
0006B0 _H	0006DC _H	ADxCS2	-	-	-	A/D Control / Status register 2
000688 _H	0006B4 _H	RCOxH0	RCOxL0	RCOxH1	RCOxL1	Range Comparator 0,1 High/Low threshold registers
00068C _H	0006B8 _H	RCOxH2	RCOxL2	RCOxH3	RCOxL3	Range Comparator 2,3 High/Low threshold registers
000690 _H	0006BC _H	RCOxIRS				Range Comparator Inverted Range Select control
000694 _H	0006C0 _H	RCOxOF				Range Comparator Overflow flags
000698 _H	0006C4 _H	RCOxINT				Range Comparator Interrupt flags
0006A0 _H	0006CC _H	ADxCC0	ADxCC1	ADxCC2	ADxCC3	Channel control for ch 0 to 7
0006A4 _H	0006D0 _H	ADxCC4	ADxCC5	ADxCC6	ADxCC7	Channel control for ch 8 to 16
0006A8 _H	0006D4 _H	ADxCC8	ADxCC9	ADxCC10	ADxCC11	Channel control for ch 16 to 23
0006AC _H	0006D8 _H	ADxCC12	ADxCC13	ADxCC14	ADxCC15	Channel control for ch 24 to 31
0006E0 _H	000720 _H	ADCxD0		ADCxD1		ADC Channel Data register, channel 0,1
0006E4 _H	000724 _H	ADCxD2		ADCxD3		ADC Channel Data register, channel 2,3
0006E8 _H	000728 _H	ADCxD4		ADCxD5		ADC Channel Data register, channel 4,5
0006EC _H	00072C _H	ADCxD6		ADCxD7		ADC Channel Data register, channel 6,7
0006F0 _H	000730 _H	ADCxD8		ADCxD9		ADC Channel Data register, channel 8,9
0006F4 _H	000734 _H	ADCxD10		ADCxD11		ADC Channel Data register, channel 10,11
0006F8 _H	000738 _H	ADCxD12		ADCxD13		ADC Channel Data register, channel 12,13
0006FC _H	00073C _H	ADCxD14		ADCxD15		ADC Channel Data register, channel 14,15
000700 _H	000740 _H	ADCxD16		ADCxD17		ADC Channel Data register, channel 16,17
000704 _H	000744 _H	ADCxD18		ADCxD19		ADC Channel Data register, channel 18,19
000708 _H	000748 _H	ADCxD20		ADCxD21		ADC Channel Data register, channel 20,21
00070C _H	00074C _H	ADCxD22		ADCxD23		ADC Channel Data register, channel 22,23
000710 _H	000750 _H	ADCxD24		ADCxD25		ADC Channel Data register, channel 24,25
000714 _H	000754 _H	ADCxD26		ADCxD27		ADC Channel Data register, channel 26,27
000718 _H	000758 _H	ADCxD28		ADCxD29		ADC Channel Data register, channel 28,29
00071C _H	00075C _H	ADCxD30		ADCxD31		ADC Channel Data register, channel 30,31

9.4.1 A/D Input Enable Register (ADER)

This register enables the analog input functions of the A/D converter. On CY91F467PA, additionally the bit **ADCHE** in PORTEN register influences the enabling of analog input.

ADERH : Access: Word, Half-word, Byte

31	30	29	28	27	26	25	24	Bit
ADE31	ADE30	ADE29	ADE28	ADE27	ADE26	ADE25	ADE24	
0	0	0	0	0	0	0	0	Initial value
R/W	R/W	R/W	R/W	R/W	R/W	R/W	R/W	Attribute
23	22	21	20	19	18	17	16	Bit
ADE23	ADE22	ADE21	ADE20	ADE19	ADE18	ADE17	ADE16	
0	0	0	0	0	0	0	0	Initial value
R/W	R/W	R/W	R/W	R/W	R/W	R/W	R/W	Attribute

ADERL : Access: Word, Half-word, Byte

15	14	13	12	11	10	9	8	Bit
ADE15	ADE14	ADE13	ADE12	ADE11	ADE10	ADE9	ADE8	
0	0	0	0	0	0	0	0	Initial value
R/W	R/W	R/W	R/W	R/W	R/W	R/W	R/W	Attribute
7	6	5	4	3	2	1	0	Bit
ADE7	ADE6	ADE5	ADE4	ADE3	ADE2	ADE1	ADE0	
0	0	0	0	0	0	0	0	Initial value
R/W	R/W	R/W	R/W	R/W	R/W	R/W	R/W	Attribute

[ADE31-0]: A/D Input Enable

ADEn	PORTEN.ADCHE	Function
0 [initial]	X	Analog input of A/D channel n is disabled. The ADC will not sample/convert this channel.
1	0 [initial]	Analog input of the channel n is enabled. Additionally, the port function register (PFR,EPFR) of the corresponding port must be set . The PFR/EPFR will switch the port to input direction (output driver = HiZ) and disable the digital input lines.
	1	Analog input of the channel n is enabled. Setting the port function register(s) is not necessary. ADEn will disable the digital input lines of the ports, but it does not change the port's direction.

- Software reset (RST) clears ADEn and PORTEN.ADCHE to 0.
- Be sure to set start channel and end channel to cover all enabled channels.

9.4.2 A/D Control Status Registers (ADCS2, ADCS1, ADCS0)

The A/D control status registers control and show the status of A/D converter. Do not overwrite ADCS0 register during A/D converting.

ADCS2 : Access: Byte

15	14	13	12	11	10	9	8	Bit
BUSY	INT	INTE	PAUS	-	-	INT2	INTE2	
0	0	0	0	0	0	0	0	Initial value
R	R	R	R	R0	R0	R/W	R/W	Attribute

[bits 15:12] BUSY, INT, INTE, PAUS

These bits are a mirror of the corresponding bits in ADCS1, intended to quickly read out all status and interrupt information using only one register access. To write the bits, access them via ADCS1.

[bits 11:10] -

These bits do not exist. Read operation returns 0.

[bit 9] INT2 (End of Scan Flag)

The End of Scan flag is set when conversion data of the last channel is stored in ADCR, whereas the last channel is defined by ADECH register setting.

- If bit 8 (INTE2) is "1" when this bit is set, and the ADC runs in continuous conversion mode, an End of Scan interrupt request is generated or, if activation of DMA is enabled, DMA is activated.
- Only clear this bit by writing "0" when A/D conversion is halted.
- Initialized to "0" by a reset.
- If DMA is used, this bit is cleared at the end of DMA transfer.
- Read-modify-write operations read this bit as "1".

[bit 8] INTE2 (Enable End of Scan Interrupt)

INTE2 enables the End of Scan interrupt in continuous conversion mode. In the other conversion modi, this bit has no effect. Additionally, setting INTE2 changes the protect function of converted data (see description of ADCS1.PAUS).

INTE2	Function
0 [initial]	Disable End of Scan interrupt, ADC result protection protects the ADCR register data.
1	Enable End of Scan interrupt, ADC result protection protects the ADCD0...ADCD31 register data (in continuous conversion mode only)

ADCS1 : Access: Half-word, Byte

15	14	13	12	11	10	9	8	Bit
BUSY	INT	INTE	PAUS	STS1	STS0	STRT	reserved	
0	0	0	0	0	0	0	0	Initial value
R/W	R/W	R/W	R/W	R/W	R/W	R/W	R/W	Attribute

[bit 15] BUSY (busy flag and stop)

BUSY	Function
Reading	A/D converter operation indication bit. Set on activation of A/D conversion and cleared on completion.
Writing	Writing "0" to this bit during A/D conversion forcibly terminates conversion. Use to forcibly terminate in continuous and stop modes.

- Read-modify-write instructions read the bit as "1".
- Cleared on the completion of A/D conversion in single conversion mode.
- In continuous and stop mode, the flag is not cleared until conversion is terminated by writing "0".
- Initialized to "0" by a software reset (RST).
- Do not specify forcible termination and software activation (BUSY="0" and STRT="1") at the same time.

[bit 14] INT (End of Conversion Interrupt flag)

This bit is set when conversion data is stored in ADCR.

- If bit 5 (INTE) is "1" when this bit is set, an interrupt request is generated or, if activation of DMA is enabled, DMA is activated.
- Only clear this bit by writing "0" when A/D conversion is halted.
- Initialized to "0" by a software reset (RST).
- If DMA is used, this bit is cleared at the end of DMA transfer.

[bit 13] INTE (End of Conversion Interrupt enable)

This bit is enables or disables the conversion completion interrupt.

INTE	Function
0	Disable interrupt [Initial value]
1	Enable interrupt

- Cleared by a software reset (RST).

[bit 12] PAUS (A/D converter pause)

This bit is set when A/D conversion temporarily halts.

The A/D converter has one register to store the conversion result (ADCR) and additionally 32 ADC channel data registers. If a conversion is finished and the data of the previous conversion has not been read out before, previous data would be overwritten.

To avoid this problem, the next conversion data is not stored in the data registers until the previous value has been read out (e.g. by DMA). A/D conversion halts during this time. A/D conversion resumes when the ADC interrupt flag ADCR1.INT is cleared.

The register protection function depends on the conversion mode and the setting of ADCR2.INTE2:

Mode	INTE2	Function
Single, Stop	X	Protect ADCR (the common result register)
Continuous	0	Protect ADCR (the common result register)
	1	Protect ADCD0...ADCD31 (the dedicated channel data registers)

- In continuous mode with INTE2==1, PAUS is set when data of the start channel (set by ADSCH) is ready for writing to the registers, but IRQ2 (End of Scan interrupt) is active.
- In the other modes or if INTE2==0, PAUS is set when data of any channel is ready for writing to the registers, but IRQ (End of Conversion) is active.
- PAUS is cleared by writing "0" or by a reset. (Not cleared at the end of DMA transfer.) However when waiting condition of DMA transfer, this bit cannot be cleared.
- Regarding protect function of converted data, see Section 9.6 "Operation of A/D Converter".

[bit 11, 10] STS1, STS0 (Start source select)

These bits select the A/D activation source.

STS1	STS0	Function
0	0	Software activation [Initial value]
0	1	External trigger pin activation and software activation
1	0	Timer activation and software activation
1	1	External trigger pin activation, timer activation and software activation

- These bits are initialized "00" by software reset (RST).
- In multiple-activation modes, the first activation to occur starts A/D conversion.
- The activation source changes immediately on writing to the register. Therefore care is required when switching activation mode during A/D operation.
- The A/D converter detects falling edges on the external trigger pin. When external trigger level is "L" and if these bits are changed to external trigger activation mode, A/D converting may start.
- Selecting the timer selects the 16-bit reload timer 7.

[bit 9] STRT (Start)

Writing "1" to this bit starts A/D conversion (software activation).

- Write "1" again to restart conversion.
- Initialized to "0" by a software reset (RST).
- In continuous and stop mode, restarting is not occurred. Check BUSY bit before writing "1". (Activate conversion after clearing.)
- Do not specify forcible termination and software activation (BUSY="0" and STRT="1") at the same time.

[bit 8] reserved bit

Always write "0" to this bit.

ADCS0 : Access: Half-word, Byte

7	6	5	4	3	2	1	0	Bit
MD1	MD0	S10	ACH4	ACH3	ACH2	ACH1	ACH0 / ACHMD	
0	0	0	0	0	0	0	0	Initial value
R/W	R/W	R/W	R	R	R	R	R,W	Attribute

[bit 7, 6] MD1, MD0 (A/D converter mode set)

These bits the operation mode.

MD1	MD0	Operating mode
0	0	Single mode 1 (Reactivation during A/D conversion is allowed)
0	1	Single mode 2 (Reactivation during A/D conversion is not allowed)
1	0	Continuous mode (Reactivation during A/D conversion is not allowed)
1	1	Stop mode (Reactivation during A/D conversion is not allowed)

- Single mode: A/D conversion is continuous performed from the selected start channel (ADSCH) to the selected end channel (ADECH). The conversion stops once it has been done for all these channels.
- Continuous mode: A/D conversion is repeatedly performed from the selected start channel (ADSCH) to the selected end channel (ADECH) in a row.
- Stop mode: A/D conversion is performed from the selected start channel (ADSCH) to the selected end channel (ADECH), followed by a pause after each channel. The conversion is resumed upon activation.

When A/D conversion is started in continuous mode or stop mode, conversion operation continued until stopped by the BUSY bit. Conversion is stopped by writing "0" to the BUSY bit.

On activation after forcibly stopping, conversion starts from the start channel, selected by ADSCH register.

Reactivation during A/D conversion is disabled for any of the timer, external trigger and software start sources in single mode 2, continuous and stop mode.

[bit 5] S10

This bit defines resolution of A/D conversion. If this bit set "0", the resolution is 10-bit. In the other case, resolution is 8-bit and the conversion result is stored to ADCR0 and in the lower 8 bits of the dedicated ADC result registers.

Initialized to "0" by a reset.

[bit 4 to 0] ACH4-0 (Analog convert select channel, read-only)

These bits show the number of the currently or previously converted analog channel, depending on bit ACHMD (see below).

ACH4	ACH3	ACH2	ACH1	ACH0	Converted channel
0	0	0	0	0	AN0
0	0	0	0	1	AN1
...					...
1	1	1	1	0	AN30
1	1	1	1	1	AN31

- Writing these bits has no effect (bit 0 is writable with special function ADCHMD).
- Initialized to "0000" by software reset (RST).

[bit 0] ACHMD (ACH register mode, write-only)

For reading out the ACH4-0 register bits (see below), there is a *direct* mode and a *latched* mode.

In direct mode, ACH4-0 shows the number of the ADC channel which is *currently in conversion*, e.g. the internal conversion channel pointer. This pointer is incremented immediately after a conversion is finished.

In latched mode, ACH4-0 shows the number of the ADC channel whose conversion was *finished previously*. After a conversion is finished, the conversion channel pointer is latched and the latched data can be read in this mode. At the end of the next conversion, the latch is overwritten if no PAUSE condition exists.

ACHMD	Function
0	Direct ACH register mode [Initial value]
1	Latched ACH register mode

- ACHMD is a write-only bit.
- Read- or read-modify-write access returns the value of bit ACH0, see below.
- Initial value is 0.

9.4.3 Common Data Register (ADCR1, ADCR0)

These registers store the conversion results of the A/D converter. ADCR0 stores lower 8-bit. ADCR1 stores upper 2-bit. The register values are updated at the completion of each conversion. The registers normally store the results of the previous conversion.

ADCR1 : Access: Word, Half-word, Byte

15	14	13	12	11	10	9	8	Bit
-	-	-	-	-	-	D9	D8	
0	0	0	0	0	0	X	X	Initial value
R0, W0	R0, W0	R0, W0	R0, W0	R0, W0	R0, W0	R	R	Attribute

ADCR0 : Access: Word, Half-word, Byte

7	6	5	4	3	2	1	0	Bit
D7	D6	D5	D4	D3	D2	D1	D0	
X	X	X	X	X	X	X	X	Initial value
R	R	R	R	R	R	R	R	Attribute

- Bit 15 to 10 of ADCR1 are read as "0".
- The A/D converter has a conversion data protection function. See the "Operation" section for further information.

9.4.4 Dedicated A/D Channel Data Register (ADCD0 to ADCD31)

There are 32 ADC result data registers, one per channel. The registers are written by hardware at the end of conversion of the attached channel. ADCD0 is attached to channel 0, ADCD31 is attached to channel 31.

ADCD0 ... ADCD31 : Access: Word, Half-word, Byte

15	14	13	12	11	10	9	8	Bit
-	-	-	-	-	-	D9	D8	
0	0	0	0	0	0	X	X	Initial value
R0	R0	R0	R0	R0	R0	R	R	Attribute
7	6	5	4	3	2	1	0	Bit
D7	D6	D5	D4	D3	D2	D1	D0	
X	X	X	X	X	X	X	X	Initial value
R	R	R	R	R	R	R	R	Attribute

- Bit 15 to 10 of the ADCD registers are read as "0".
- The A/D converter has a conversion data protection function. In continuous conversion mode, the protection function can be changed to protect the A/D Channel Data registers rather than the A/D Data Register (ADCR1). See section 9.6.6 "Protection of the ADC Channel Data Registers" for further information.

9.4.5 Sampling Timer Setting Register (ADCT)

ADCT register controls the sampling time and comparison time of analog input. This register sets A/D conversion time. Do not update value of this register during A/D conversion operation.

ADCT1: Access: **Word, Half-word, Byte**

15	14	13	12	11	10	9	8	Bit
CT5	CT4	CT3	CT2	CT1	CT0	ST9	ST8	
0	0	0	1	0	0	0	0	Initial value
R/W	R/W	R/W	R/W	R/W	R/W	R/W	R/W	Attribute

ADCT0: Access: **Word, Half-word, Byte**

7	6	5	4	3	2	1	0	Bit
ST7	ST6	ST5	ST4	ST3	ST2	ST1	ST0	
0	0	1	0	1	1	0	0	Initial value
R/W	R/W	R/W	R/W	R/W	R/W	R/W	R/W	Attribute

[bit 15 to 10] CT5-0 (A/D comparison time set)

These bits specify clock division of comparison time.

- Setting "000001" means one division (=CLKP).
- Do not set these bits "000000".
- Initialized these bits to "000100" by software reset (RST).
- Comparison time = CT value * CLKP cycle * 10 + (4 * CLKP)
- Do not set comparison time over 500 μ s.

[bit 9 to 0] ST9-0 (Analog input sampling time set)

These bits specify sampling time of analog input.

- Initialized these bits to "0000101100" by software reset (RST).
- Sampling time = ST value * CLKP cycle
- Do not set sampling time below 1.2 μ s when AVCC is below 4.5 V.

Necessary sampling time and ST value are calculated by following.

- Necessary sampling time (Tsamp) = (Rext + Rin) * Cin * 7
- ST9 to ST0 = Tsamp / CLKP cycle

ST has to be set that sampling time is over Tsamp.

Example: CLKP = 32MHz, AVCC \geq 4.5V, Rext = 200K Ω

$$Tsamp = (200 * 10^3 + 2.52 * 10^3) * 10.7 * 10^{-12} * 7 = 15.17 [\mu s]$$

$$ST = 15.17^{-6} / 31.25^{-9} = 485.44$$

ST has to be set over 486_D (111100110_B).

Tsamp is decided by Rext. Thus conversion time should be considered together with Rext.

9.4.6 A/D Channel Setting Register (ADSCH, ADECH)

These registers specify the channels for the A/D converter to convert. Do not update these registers while the A/D converting is operating.

ADSCH: Access: Word, Half-word, Byte

15	14	13	12	11	10	9	8	Bit
-	-	-	ANS4	ANS3	ANS2	ANS1	ANS0	
-	-	-	0	0	0	0	0	Initial value
RX, W0	RX, W0	RX, W0	R/W	R/W	R/W	R/W	R/W	Attribute

ADECH : Access: Word, Half-word, Byte

7	6	5	4	3	2	1	0	Bit
-	-	-	ANE4	ANE3	ANE2	ANE1	ANE0	
-	-	-	0	0	0	0	0	Initial value
RX, W0	RX, W0	RX, W0	R/W	R/W	R/W	R/W	R/W	Attribute

These bits set the start and end channel for A/D converter.

- Setting of ANE4 to ANE0 the same channel as in ANS4 to ANS0 specifies conversion for that channel only. (Single conversion)
- In continuous or stop mode, conversion is performed up to the channel specified by ANE4 to ANE0. Conversion then starts again from the start channel specified by ANS4 to ANS0.
- If ANS > ANE, conversion starts with the channel specified by ANS, continuous up to channel 31, starts again from channel 0, and ends with the channel specified by ANE.
- Initialized to ANS="00000", ANE="00000" by a software reset (RST).

Example: Channel Setting ANS=30ch, ANE=3ch, single conversion mode

Operation : Conversion channel 30ch -> 31ch -> 0ch -> 1ch -> 2ch -> 3ch end

[bit 12 to 8] ANS4-0 (Analog start channel set)

[bit 4 to 0] ANE4-0 (Analog end channel set)

ANS4 ANE4	ANS3 ANE3	ANS2 ANE2	ANS1 ANE1	ANS0 ANE0	Start / End Channel
0	0	0	0	0	AN0
0	0	0	0	1	AN1
0	0	0	1	0	AN2
0	0	0	1	1	AN3
...					...
1	1	1	0	1	AN29
1	1	1	1	0	AN30
1	1	1	1	1	AN31

9.5 Range Comparator

9.5.1 Range Comparator Structure

The Range Comparator has 4 comparison groups with an upper and a lower threshold register each. The 32 ADC channels can be enabled for range comparison and assigned to one of the 4 comparators individually. If enabled, the comparison will set up to 2 flags for this ADC channel:

- An interrupt flag RCOINT, signalling that the ADC result is outside the range or, by “inverted” configuration, inside the range.
- An overflow flag RCOOF, showing that the range violation was an overflow and no underflow.

Furthermore, each ADC channel can be enabled to send an interrupt request to the CPU, if the RCOINT flag is set.

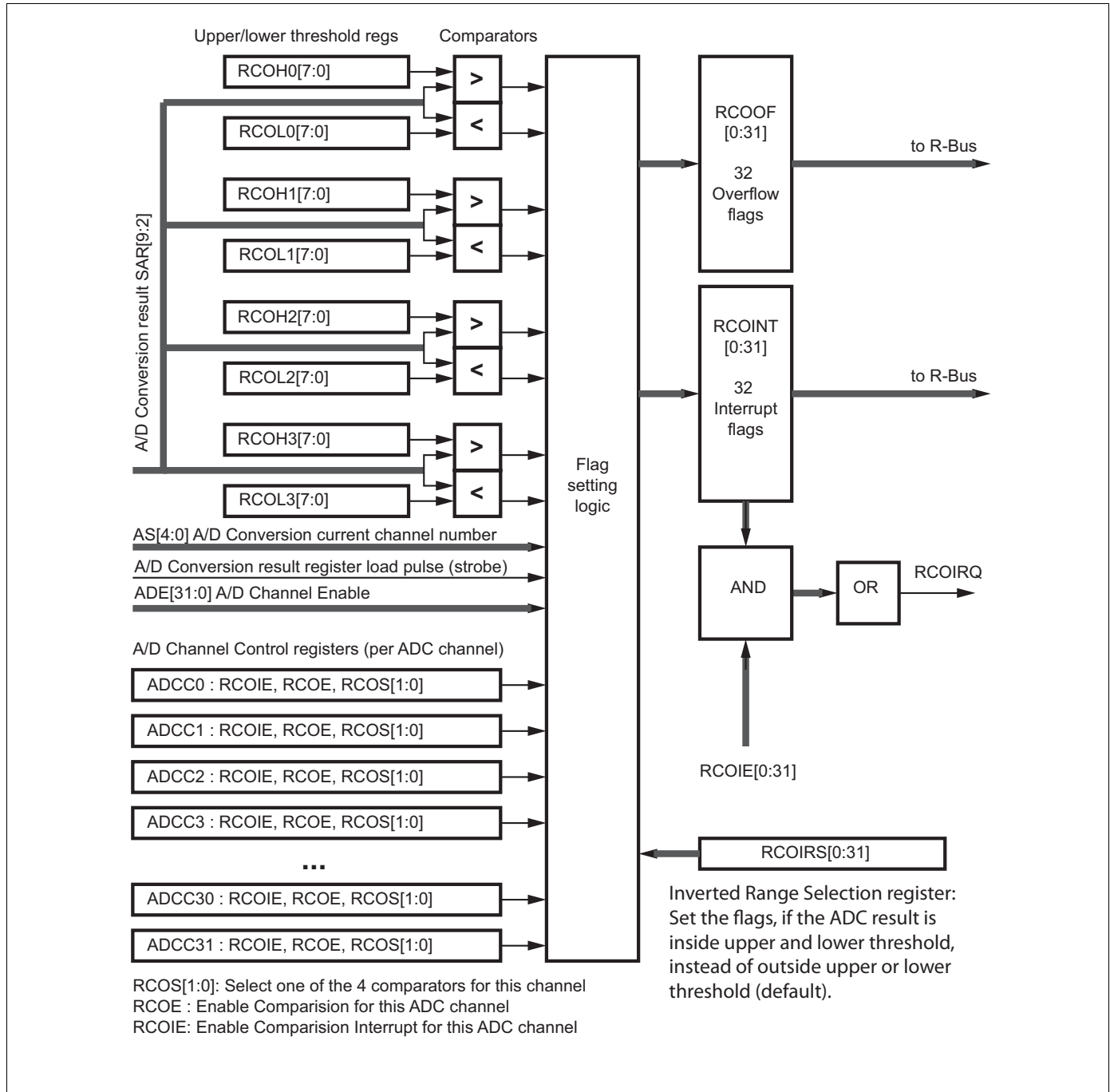

9.5.2 Range Comparator Registers

The Range Comparator (RCO) has the following registers:

- RCOHx[7:0] : Upper threshold register, one register per comparator block (x = 0...3)
- RCOLx[7:0] : Lower threshold register, one register per comparator block (x = 0...3)
- ADCCm[7:0] : ADC channel control, one register per 2 ADC channels (m = 0...15)
- RCOIRS[0:31] : RCO Inverted Range Selection, one bit per ADC channel
- RCOOF[0:31] : RCO Overflow Flags, one bit per ADC channel, read-only
- RCOINT[0:31] : RCO Interrupt Flags, one bit per ADC channel

Range Comparator Threshold registers (RCOH0/L0 to RCOH3/L3)

RCOH0-3 : Higher threshold, access: **Word, Half-word, Byte**

15	14	13	12	11	10	9	8	Bit
RCOH7	RCOH6	RCOH5	RCOH4	RCOH3	RCOH2	RCOH1	RCOH0	
1	1	1	1	1	1	1	1	Initial value
R/W	R/W	R/W	R/W	R/W	R/W	R/W	R/W	Attribute

[bit 7:0] RCOH[7:0] (Range Comparator High threshold)

The RCOH bits define the higher comparison threshold of the Range Comparator channel.

The upper Range Comparator compares that the upper 8 bits of the ADC conversion result are higher then RCOH[7:0] .

RCOL0-3 : Lower threshold, access: **Word, Half-word, Byte**

7	6	5	4	3	2	1	0	Bit
RCOL7	RCOL6	RCOL5	RCOL4	RCOL3	RCOL2	RCOL1	RCOL0	
0	0	0	0	0	0	0	0	Initial value
R/W	R/W	R/W	R/W	R/W	R/W	R/W	R/W	Attribute

[bit 7:0] RCOL[7:0] (Range Comparator Low threshold)

The RCOL bits define the lower comparison threshold of the Range Comparator channel.

The lower Range Comparator compares that the upper 8 bits of the ADC conversion result are lower then RCOL[7:0] .

A/D Converter Channel Control registers (ADCC0 to ADCC15)

The A/D channel control registers serve 2 ADC channels per register and control the range comparison for these channels.

- ADCC0 register controls A/D channels 0 + 1,
- ADCC1 register controls A/D channels 2 + 3,
- ...
- ADCC15 register controls A/D channels 30 + 31

ADCC0-15: Access: Word, Half-word, Byte

7	6	5	4	3	2	1	0	Bit
RCOIE1	RCOE1	RCOS11	RCOS10	RCOIE0	RCOE0	RCOS01	RCOS00	
0	0	0	0	0	0	0	0	Initial value
R/W	R/W	R/W	R/W	R/W	R/W	R/W	R/W	Attribute
Bits 7:4 control A/D channels 1,3,5,7,...31				Bits 3:0 control A/D channels 0,2,4,6,...,30				

[bit 7,3] RCOIE1, RCOIE0 (Range Comparator Interrupt enable)

The RCOIE bits enable the Range Comparator interrupt for the corresponding ADC channel.

RCOIE	Function
0	RCO interrupt for this ADC channel is disabled [default]
1	RCO interrupt for this ADC channel is enabled

[bit 6,2] RCOE1, RCOE0 (Range Comparator operation enable)

The RCOE bits enable the Range Comparison for the corresponding ADC channel:

RCOE	Function
0	RCO disabled, RCO flags for this ADC channel will not be set [default]
1	RCO enabled for this ADC channel

[bits 5:4,1:0] RCOS1[1:0], RCOS0[1:0] (converter channel select)

These bits select the A/D converter channel to be assigned to the Range Comparator channel:

RCOS[1:0]	Function
00	Select range comparator channel 0 for this ADC channel [default]
01	Select range comparator channel 1 for this ADC channel
10	Select range comparator channel 2 for this ADC channel
11	Select range comparator channel 3 for this ADC channel

Inverted Range Selection register

The RCOIRS register controls that the comparison should check for “out of range” or “inside range”. The 32 bits of RCOIRS is organized “per ADC channel”. ADC channel 0 is located on the MSB of the register and ADC channel 31 is on the LSB.

RCOIRS : Access: Word, Half-word, Byte

31	30	29	28	27	26	25	24	Bit
RCOIRS0	RCOIRS1	RCOIRS2	RCOIRS3	RCOIRS4	RCOIRS5	RCOIRS6	RCOIRS7	
0	0	0	0	0	0	0	0	Initial value
R/W	R/W	R/W	R/W	R/W	R/W	R/W	R/W	Attribute
23	22	21	20	19	18	17	16	Bit
RCOIRS8	RCOIRS9	RCOIRS10	RCOIRS11	RCOIRS12	RCOIRS13	RCOIRS14	RCOIRS15	
0	0	0	0	0	0	0	0	Initial value
R/W	R/W	R/W	R/W	R/W	R/W	R/W	R/W	Attribute
15	14	13	12	11	10	9	8	Bit
RCOIRS16	RCOIRS17	RCOIRS18	RCOIRS19	RCOIRS20	RCOIRS21	RCOIRS22	RCOIRS23	
0	0	0	0	0	0	0	0	Initial value
R/W	R/W	R/W	R/W	R/W	R/W	R/W	R/W	Attribute
7	6	5	4	3	2	1	0	Bit
RCOIRS24	RCOIRS25	RCOIRS26	RCOIRS27	RCOIRS28	RCOIRS29	RCOIRS30	RCOIRS31	
0	0	0	0	0	0	0	0	Initial value
R/W	R/W	R/W	R/W	R/W	R/W	R/W	R/W	Attribute

Note that bit[31] is assigned to ADC channel 0, bit[30] is assigned to ADC channel one and so on.

[bits 31:0] RCOIRS[0:31] (Inverted Range Select)

The RCOIRS bits control how the Range Comparator result flags are set.

- If the RCOIRS[n] is 0, the flags are set when the ADC result is above the upper threshold OR below the lower threshold. That is called “**out of range**” mode.
- If the RCOIRS[n] is 1, the flags are set when the ADC result is below or equal the upper threshold AND above or equal the lower threshold. That is called “**inside range**” mode.

RCOIRSn	Function
0	Range comparison for this ADC channel checks for “out of range” (default)
1	Range comparison for this ADC channel checks for “inside range”

Range Comparator Result Flags

The result of range comparison is stored in 2 flag registers:

- RCOINT[0:31]: Range comparison interrupt flags
- RCOOF[0:31]: Range comparison overflow flags

The Range Comparator Result flags are organized “per ADC channel”. There are 32 Range Comparator overflow flags and 32 interrupt flags. In case of a RCO interrupt, all interrupt flags can be read out by one 32-bit read operation and analyzed using the Bit Search Unit. The Bit Search Unit will return the number of the interrupting channel. Since bit search works from MSB to LSB (from left to right), ADC channel 0 is located on the MSB of the registers and ADC channel 31 is on LSB.

RCOINT : Access: Word, Half-word, Byte

31	30	29	28	27	26	25	24	Bit
RCOINT0	RCOINT1	RCOINT2	RCOINT3	RCOINT4	RCOINT5	RCOINT6	RCOINT7	
0	0	0	0	0	0	0	0	Initial value
R/W0	R/W0	R/W0	R/W0	R/W0	R/W0	R/W0	R/W0	Attribute
23	22	21	20	19	18	17	16	Bit
RCOINT8	RCOINT9	RCOINT10	RCOINT11	RCOINT12	RCOINT13	RCOINT14	RCOINT15	
0	0	0	0	0	0	0	0	Initial value
R/W0	R/W0	R/W0	R/W0	R/W0	R/W0	R/W0	R/W0	Attribute
15	14	13	12	11	10	9	8	Bit
RCOINT16	RCOINT17	RCOINT18	RCOINT19	RCOINT20	RCOINT21	RCOINT22	RCOINT23	
0	0	0	0	0	0	0	0	Initial value
R/W0	R/W0	R/W0	R/W0	R/W0	R/W0	R/W0	R/W0	Attribute
7	6	5	4	3	2	1	0	Bit
RCOINT24	RCOINT25	RCOINT26	RCOINT27	RCOINT28	RCOINT29	RCOINT30	RCOINT31	
0	0	0	0	0	0	0	0	Initial value
R/W0	R/W0	R/W0	R/W0	R/W0	R/W0	R/W0	R/W0	Attribute

Note that bit[31] is assigned to ADC channel 0, bit[30] is assigned to ADC channel one and so on.

[bits 31:0] RCOINT[0:31] (Range Comparator Interrupt flags)

The RCOINT flags show that a “out of range” or “inside range” condition has been found on the ADC channel.

The bits are set under the following condition:

- the ADC channel is enabled ADER.ADE[i] is set and
- the range comparison for this channel is enabled ADCCn.RCOE[i] is set and
- the conversion of the ADC channel is just finished and
- an interrupt condition was found (see the table on next page).

- The bits are cleared by writing 0 or by software reset (RST). Writing 1 has no effect.
- Read-modify-write operations read 1.

The interrupt condition depends on the comparison results and the RCOIRS setting for this channel:

Mode	RCOIRS	Upper threshold comparator	Lower threshold comparator	Interrupt condition
out of range	0	1	x	INT condition: above range, RCOOF is set
		0	0	-
		x	1	INT condition: below range, RCOOF is cleared
inside range	1	1	x	-
		0	0	INT condition: inside range
		x	1	-

Note: The upper threshold comparator returns 1 if the upper 8 bits of the ADC result are greater than the threshold value in RCOH[7:0]. The lower threshold comparator returns 1 if the upper 8 bits of the ADC result are smaller than the threshold value in RCOL[7:0].

RCOnOF : Access: Read-only, Word, Half-word, Byte

31	30	29	28	27	26	25	24	Bit
RCOOF0	RCOOF1	RCOOF2	RCOOF3	RCOOF4	RCOOF5	RCOOF6	RCOOF7	
0	0	0	0	0	0	0	0	Initial value
R	R	R	R	R	R	R	R	Attribute
23	22	21	20	19	18	17	16	Bit
RCOOF8	RCOOF9	RCOOF10	RCOOF11	RCOOF12	RCOOF13	RCOOF14	RCOOF15	
0	0	0	0	0	0	0	0	Initial value
R	R	R	R	R	R	R	R	Attribute
15	14	13	12	11	10	9	8	Bit
RCOOF16	RCOOF17	RCOOF18	RCOOF19	RCOOF20	RCOOF21	RCOOF22	RCOOF23	
0	0	0	0	0	0	0	0	Initial value
R	R	R	R	R	R	R	R	Attribute
7	6	5	4	3	2	1	0	Bit
RCOOF24	RCOOF25	RCOOF26	RCOOF27	RCOOF28	RCOOF29	RCOOF30	RCOOF31	
0	0	0	0	0	0	0	0	Initial value
R	R	R	R	R	R	R	R	Attribute

Note that bit[31] is assigned to ADC channel 0, bit[30] is assigned to ADC channel one and so on.

[bits 31:0] RCOOF[0:31] (Range Comparator Overflow flag)

The RCOOF read-only flags store the output signal of the upper threshold comparator at the time when an interrupt condition (see above) appeared and the corresponding RCOINT flag was **not** set. So the RCOOF flags indicate the upper comparator state when the RCOINT flag had the last rising edge.

The RCOOF flag for a ADC channel is loaded with the upper threshold comparator output signal under the following condition:

- the corresponding RCOINT flag is not yet set and
- the corresponding RCOINT flag has a set condition in this cycle.

The flags are initialized by software reset (RST).

RCOOFn	Function
0	The output of the upper threshold comparator was 0 [default]
1	The output of the upper threshold comparator was 1

9.5.3 Range Comparator Interrupt request

The Range Comparator has one interrupt output line RCOIRQ. The interrupt output line becomes active if at least one of the Range Comparator interrupt flags RCOINT[31:0] is set and the corresponding interrupt enable bit in the ADCC registers is set.

It is not possible to activate a DMA request from the range comparator interrupts.

9.6 Operation of A/D Converter

The A/D converter operates using the successive approximation method with 10-bit or 8-bit resolution. There is one 16-bit register provided to store conversion results (ADCR), which is updated each time conversion completes. Additionally, there is one ADC Channel Data register per channel (ADCD0...31), which is updated each time the assigned channel is converted. The Channel Data registers especially improve the continuous conversion mode.

It is recommended to use the DMA service. The following describes the operation modes.

9.6.1 Single Mode

In single conversion mode, the analog input signals selected by the ANS bits and ANE bits are converted in order until the completion of conversion on the end channel determined by the ANE bits. A/D conversion then ends. If the start channel and end channel are the same (ANS=ANE), only a single channel conversion is performed.

Examples:

- ANS=00000b, ANE=00011b
Start -> AN0 -> AN1 -> AN2 -> AN3 -> End
- ANS=00010b, ANE=00010b
Start -> AN2 -> End

9.6.2 Continuous Mode

In continuous mode the analog input signals selected by the ANS bits and ANE bits are converted in order until the completion of conversion on the end channel determined by the ANE bits, then the converter returns to the ANS channel for analog input and repeats the process continuously. When the start and end channels are the same (ANS=ANE), conversion is performed continuously for that channel.

Examples:

- ANS=00000b, ANE=00011b
Start -> AN0 -> AN1 -> AN2 -> AN3 -> AN0 ... -> repeat
- ANS=00010b, ANE=00010b
Start -> AN2 -> AN2 -> AN2 ... -> repeat

In continuous mode, conversion is repeated until '0' is written to the BUSY bit. (Writing '0' to the BUSY bit forcibly stops the conversion operation.) Note that forcibly terminating operation halts the current conversion during mid-conversion. (If operation is forcibly terminated, the value in the conversion register is the result of the most recently completed conversion.)

9.6.3 Stop Mode

In stop mode the analog input signal selected by the ANS bits and ANE bits are converted in order, but conversion operation pauses after each channel. The pause is released by applying another start signal.

At the completion of conversion on the end channel determined by the ANE bits, the converter returns to the ANS channel for analog input signal and repeats the conversion process continuously. When the start and end channel are the same (ANS=ANE), only a signal channel conversion is performed.

Examples:

- ANS=00000b, ANE=00011b
Start -> AN0 -> stop -> start -> AN1 -> stop -> start -> AN2 -> stop -> start -> AN3 -> stop -> start -> AN0 ... -> repeat
- ANS=00010b, ANE=00010b
Start -> AN2 -> stop -> start -> AN2 -> stop -> start -> AN2 ... -> repeat

In stop mode the startup source is the source determined by the STS1, STS0 bits. This mode enables synchronization of the conversion start signal.

9.6.4 Single-shot Conversion

The following figure shows the operation of A/D converter in Single-shot conversion mode

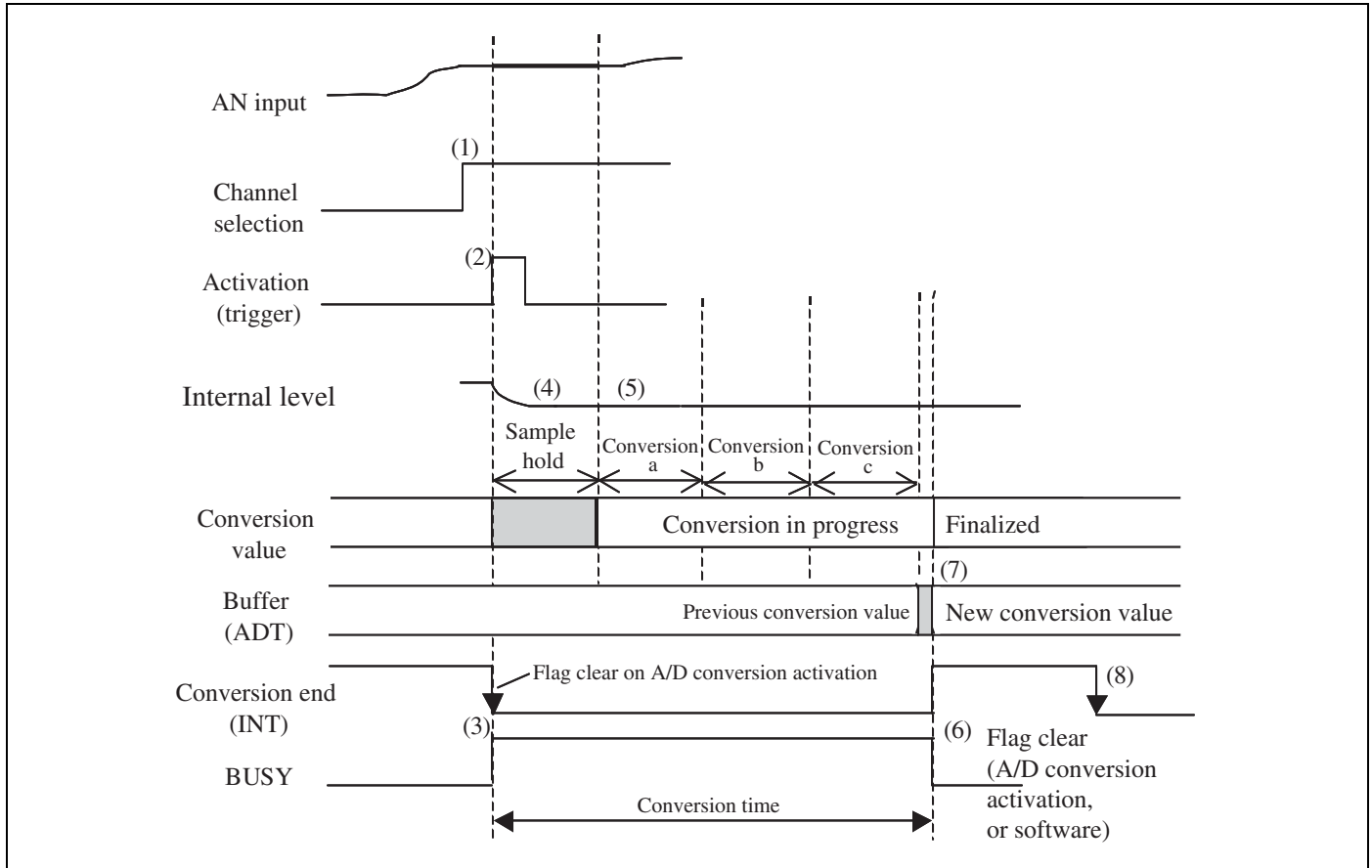

- (1) Channel selection
- (2) A/D conversion activation (Trigger input: Software trigger/Reload timer/External trigger)
- (3) INT flag clear, BUSY flag set
- (4) Sample hold
- (5) Conversion (Conversion a + Conversion b + Conversion c)
- (6) Conversion end, INT flag set, BUSY flag clear
- (7) Buffers the conversion value. Buffered data storage
- (8) Software-based INT flag clear

9.6.5 Scan Conversion

The following figure shows the operation of A/D converter in Scan conversion mode

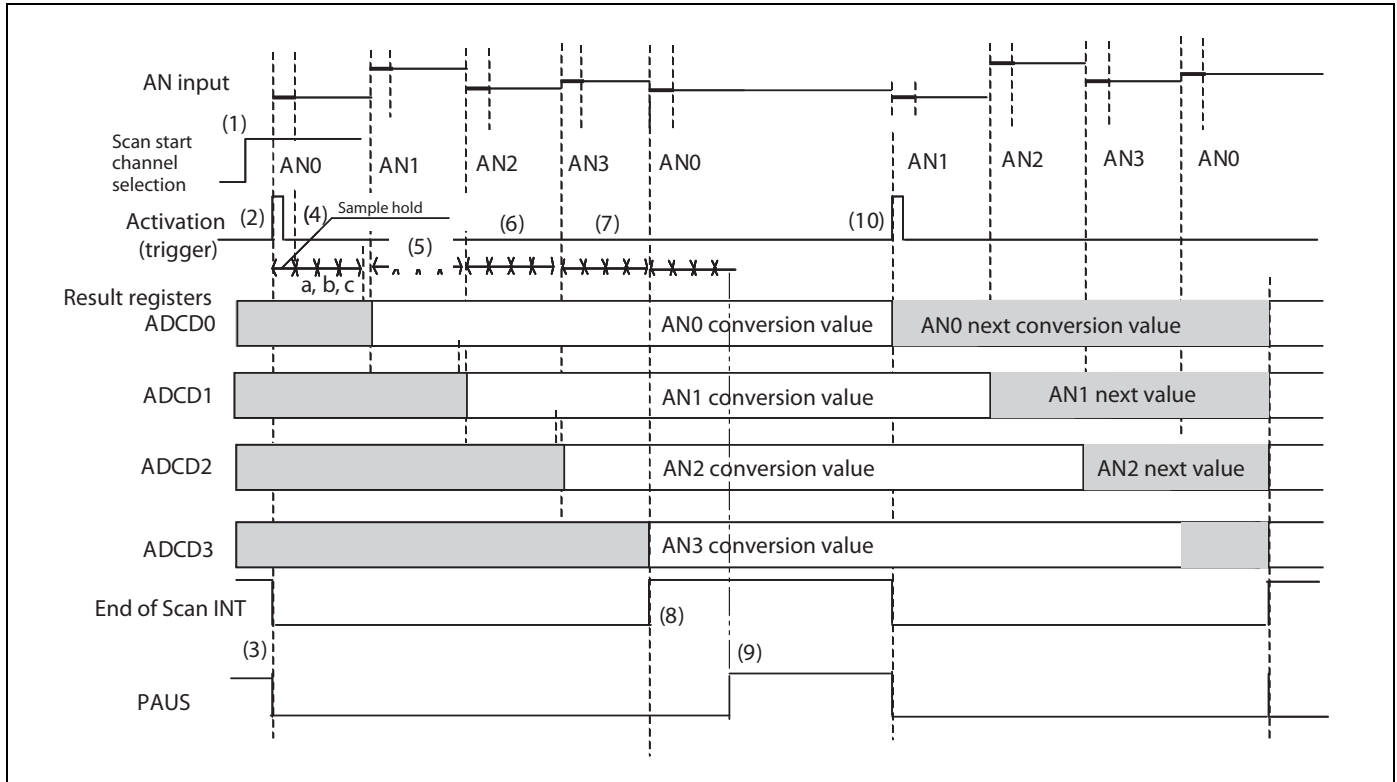

- (1) Activation channel selection
- (2) A/D activation (Trigger: Software trigger/Reload timer/External trigger)
- (3) INT flag clear, PAUS flag clear
- (4) AN0 conversion
 - a. Sample hold, conversion (conversion a + conversion b + conversion c)
 - b. Conversion end
 - c. Buffers the conversion value.
- (5) AN1 conversion
- (6) AN2 conversion
- (7) AN3 conversion
- (8) INT2 (End of Scan) flag is set, AN0 conversion starts
- (9) Because INT2 has not been cleared yet, the ADC protects the result register of AN0 against overwriting and enters PAUSE state.
- (10) INT2 flag cleared by DMA or by software, the ADC stores the result of AN0 and continues sampling AN1.

9.6.6 Protection of the ADC Channel Data Registers

There are 32 ADC result data registers, one register per channel. The registers are written by hardware at the end of conversion of the attached channel. ADCD0 is attached to channel 0, ADCD31 is attached to channel 31.

The CPU can read the data registers any time.

If a conversion is finished and the data of the previous conversion has not been read out before, previous data would be overwritten. To avoid this problem, the next conversion data is not stored in the data registers until the previous value has been read out (e.g. by DMA). A/D conversion halts during this time and the PAUS flag is set. A/D conversion restarts when the ADC interrupt flag ADCR1.INT is cleared.

The register protection function depends on the conversion mode and the setting of ADCR2.INTE2:

Mode	INTE2	Function
Single, Stop	X	Protection of ADCR
Continuous	0	Protection of ADCR
	1	Protection of ADCD0...ADCD31

Protection of ADCD0...31

In continuous mode with INTE2==1, PAUS is set when data of the **start channel (set by ADSCH)** is ready for writing to the registers, but IRQ2 (End of Scan interrupt) is already active.

Example: Start channel =4, end channel=7, continuous mode, ADCS1.INTE=0, ADCS2.INTE2=1

Start by CPU --> convert channel 4 + save data to ADCD4,
 convert channel 5 + save data to ADCD5,
 convert channel 6 + save data to ADCD6,
 convert channel 7 + save data to ADCD7 ----> End of Scan interrupt (IRQ2),
 convert channel 4 + set PAUS (protect ADCD4...7).

After the CPU or DMA have read the data registers and cleared IRQ2, the scan conversion continues.

Protection of ADCR

In the other modes or if INTE2==0, PAUS is set when data of any channel is ready for writing to the registers, but IRQ (End of Conversion) is active. Because in this mode the protection function is active after each single conversion, the ADCR register is protected.

9.7 ADC Interrupt Generation and DMA Access

There are 2 ADC interrupt sources: End of Conversion and End of Scan.

9.7.1 End of Conversion

The End of Conversion (EoC) interrupt is enabled by ADCS1.INTE bit and is compatible to the A/D converts in old devices of CY91460 series. If EoC is enabled, it appears after any conversion cycle. It is recommended to use DMA transfer to read out the data from ADCR.

9.7.2 End of Scan

The End of Scan (EoS) interrupt is enabled by ADCS2.INTE2 bit. If EoS is enabled, it appears after the conversion of the end channel, which is defined by the setting of ADECH register.

If the End of Conversion interrupt is enabled in parallel, both interrupt bits are set. In this case it is recommended that the interrupt routine reads out ADCS2 register (containing mirrored bits of ADCS1[7:4]) to check where the interrupt comes from.

9.7.3 DMA Transfer

DMA transfer can be triggered by End of Conversion interrupt or by End of Scan interrupt. The interrupts are assigned to separate DMA resource numbers (please refer to the Interrupt Vector Table).

The automatic interrupt clear after DMA transfer works for End of Conversion and for End of Scan separately.

10. Handling Devices

10.1 Preventing Latch-up

Latch-up may occur in a CMOS IC if a voltage higher than (V_{DD5} , V_{DD35} or HV_{DD5}^{*1}) or less than (V_{SS5} or HV_{SS5}^{*1}) is applied to an input or output pin or if a voltage exceeding the rating is applied between the power supply pins and ground pins. If latch-up occurs, the power supply current increases rapidly, sometimes resulting in thermal breakdown of the device. Therefore, be very careful not to apply voltages in excess of the absolute maximum ratings.

Note *1: HV_{DD5} , HV_{SS5} are available only on devices having Stepper Motor Controller.

10.2 Handling of unused input pins

If unused input pins are left open, abnormal operation may result. Any unused input pins should be connected to pull-up or pull-down resistor (2K Ω to 10K Ω) or enable internal pullup or pulldown resistors (PPER/PPCR) before the input enable (PORTEN) is activated by software. The mode pins MD_x can be connected to V_{SS5} or V_{DD5} directly. Unused ALARM input pins can be connected to AV_{SS5} directly.

10.3 Power supply pins

In CY91460 series, devices including multiple power supply pins and ground pins are designed as follows; pins necessary to be at the same potential are interconnected internally to prevent malfunctions such as latch-up. All of the power supply pins and ground pins must be externally connected to the power supply and ground respectively in order to reduce unnecessary radiation, to prevent strobe signal malfunctions due to the ground level rising and to follow the total output current ratings. Furthermore, the power supply pins and ground pins of the CY91460 series must be connected to the current supply source via a low impedance.

It is also recommended to connect a ceramic capacitor of approximately 0.1 μ F as a bypass capacitor between power supply pin and ground pin near this device.

This series has a built-in step-down regulator. Connect a bypass capacitor of 4.7 μ F (use a X7R ceramic capacitor) to VCC18C pin for the regulator.

10.4 Crystal oscillator circuit

Noise in proximity to the X0 (X0A) and X1 (X1A) pins can cause the device to operate abnormally. Printed circuit boards should be designed so that the X0 (X0A) and X1 (X1A) pins, and crystal oscillator, as well as bypass capacitors connected to ground, are located near the device and ground.

It is recommended that the printed circuit board layout be designed such that the X0 and X1 pins or X0A and X1A pins are surrounded by ground plane for the stable operation.

Please request the oscillator manufacturer to evaluate the oscillational characteristics of the crystal and this device.

10.5 Notes on using external clock

When using the external clock, it is necessary to simultaneously supply the X0 (X0A) and the X1 (X1A) pins. In the described combination, X1 (X1A) should be supplied with a clock signal which has the opposite phase to the X0 (X0A) pins. At X0 and X1, a frequency up to 16 MHz is possible.

Example of using opposite phase supply

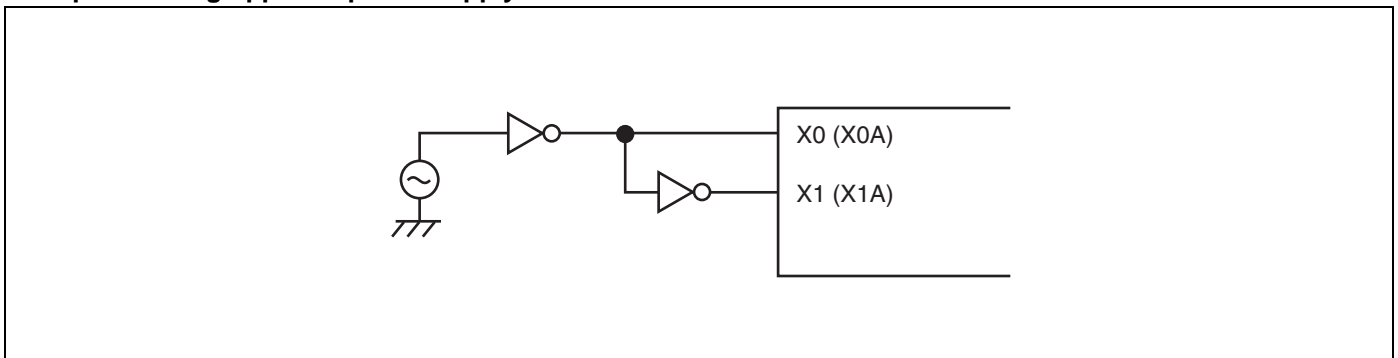

10.6 Mode pins (MD_x)

These pins should be connected directly to the power supply or ground pins. To prevent the device from entering test mode accidentally due to noise, minimize the lengths of the patterns between each mode pin and power supply pin or ground pin on the printed circuit board as possible and connect them with low impedance.

10.7 Notes on operating in PLL clock mode

If the oscillator is disconnected or the clock input stops when the PLL clock is selected, the microcontroller may continue to operate at the free-running frequency of the self-oscillating circuit of the PLL. However, this self-running operation cannot be guaranteed.

10.8 Pull-up control

The AC standard is not guaranteed in case a pull-up resistor is connected to the pin serving as an external bus pin.

11. Notes on Debugger

11.1 Execution of the RETI Command

If single-step execution is used in an environment where an interrupt occurs frequently, the corresponding interrupt handling routine will be executed repeatedly to the exclusion of other processing. This will prevent the main routine and the handlers for low priority level interrupts from being executed (For example, if the time-base timer interrupt is enabled, stepping over the RETI instruction will always break on the first line of the time-base timer interrupt handler).

Disable the corresponding interrupts when the corresponding interrupt handling routine no longer needs debugging.

11.2 Break function

If the range of addresses that cause a hardware break (including event breaks) is set to the address of the current system stack pointer or to an area that contains the stack pointer, execution will break after each instruction regardless of whether the user program actually contains data access instructions.

To prevent this, do not set (word) access to the area containing the address of the system stack pointer as the target of the hardware break (including an event breaks).

11.3 Operand break

It may cause malfunctions if a stack pointer exists in the area which is set as the DSU operand break. Do not set the access to the areas containing the address of system stack pointer as a target of data event break.

11.4 Notes on PS register

As the PS register is processed in advance by some instructions, when the debugger is being used, the exception handling may result in execution breaking in an interrupt handling routine or the displayed values of the flags in the PS register being updated.

As the microcontroller is designed to carry out reprocessing correctly upon returning from such an EIT event, the operation before and after the EIT always proceeds according to specification.

The following behavior may occur if any of the following occurs in the instruction immediately after a DIV0U/DIV0S instruction:

- (a) a user interrupt or NMI is accepted;
- (b) single-step execution is performed;
- (c) execution breaks due to a data event or from the emulator menu.
 - 1. D0 and D1 flags are updated in advance.
 - 2. An EIT handling routine (user interrupt/NMI or emulator) is executed.
 - 3. Upon returning from the EIT, the DIV0U/DIV0S instruction is executed and the D0 and D1 flags are updated to the same values as those in 1.

The following behavior occurs when an ORCCR, STILM, MOV Ri,PS instruction is executed to enable a user interrupt or NMI source while that interrupt is in the active state.

- 1. The PS register is updated in advance.
- 2. An EIT handling routine (user interrupt/NMI or emulator) is executed.
- 3. Upon returning from the EIT, the above instructions are executed and the PS register is updated to the same value as in 1.

12. Block Diagram

12.1 CY91F465PA, CY91F467PA

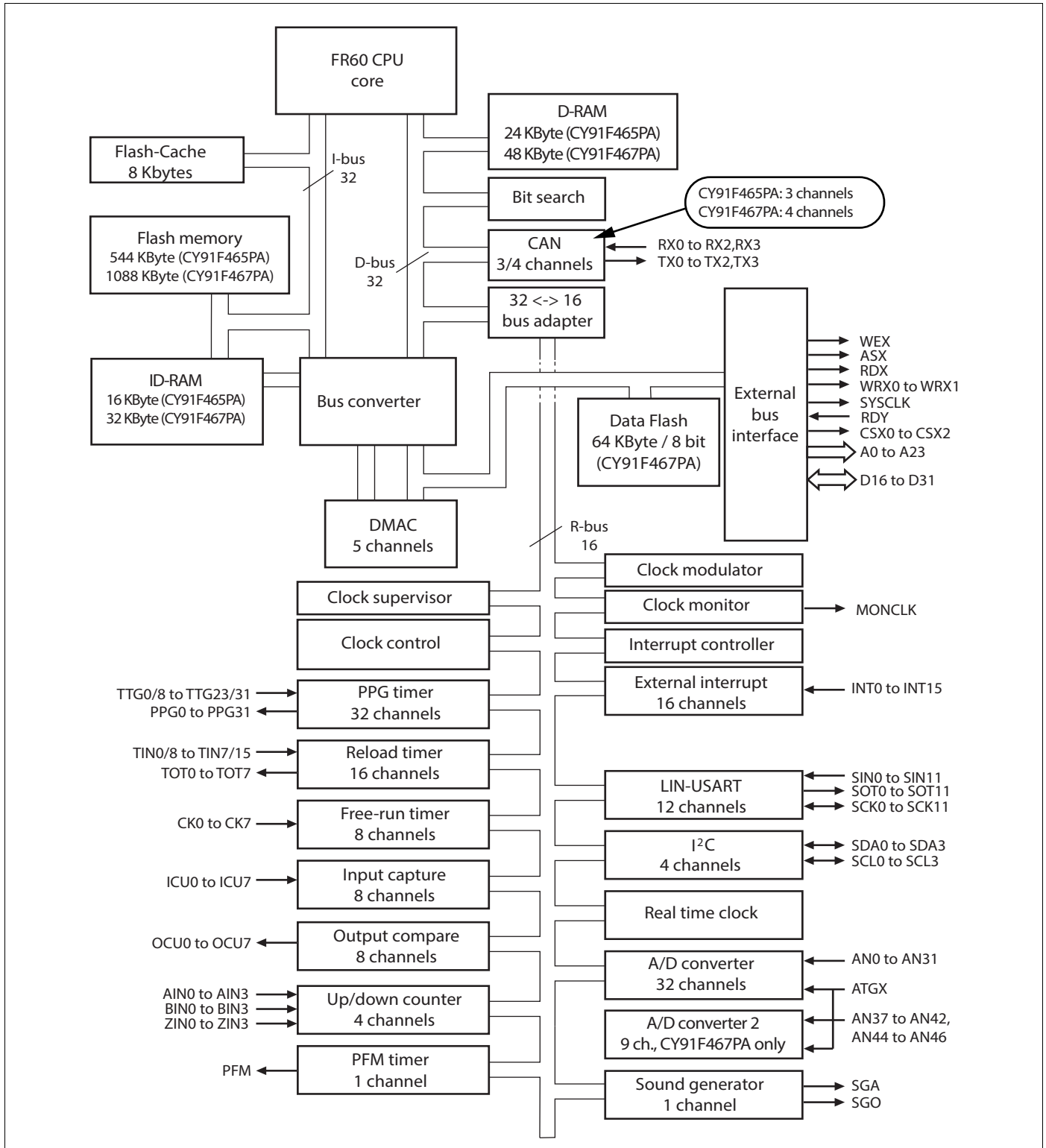

13. CPU and Control Unit

The FR family CPU is a high performance core that is designed based on the RISC architecture with advanced instructions for embedded applications.

13.1 Features

- Adoption of RISC architecture
Basic instruction: 1 instruction per cycle
- General-purpose registers: 32-bit × 16 registers
- 4 Gbytes linear memory space
- Multiplier installed
32-bit × 32-bit multiplication: 5 cycles
16-bit × 16-bit multiplication: 3 cycles
- Enhanced interrupt processing function
Quick response speed (6 cycles)
Multiple-interrupt support
Level mask function (16 levels)
- Enhanced instructions for I/O operation
Memory-to-memory transfer instruction
Bit processing instruction
Basic instruction word length: 16 bits
- Low-power consumption
Sleep mode/stop mode

13.2 Internal architecture

- The FR family CPU uses the Harvard architecture in which the instruction bus and data bus are independent of each other.
- A 32-bit ↔ 16-bit buffer is connected to the 32-bit bus (D-bus) to provide an interface between the CPU and peripheral resources.
- A Harvard ↔ Princeton bus converter is connected to both the I-bus and D-bus to provide an interface between the CPU and the bus controller.

13.3 Programming model

13.3.1 Basic programming model

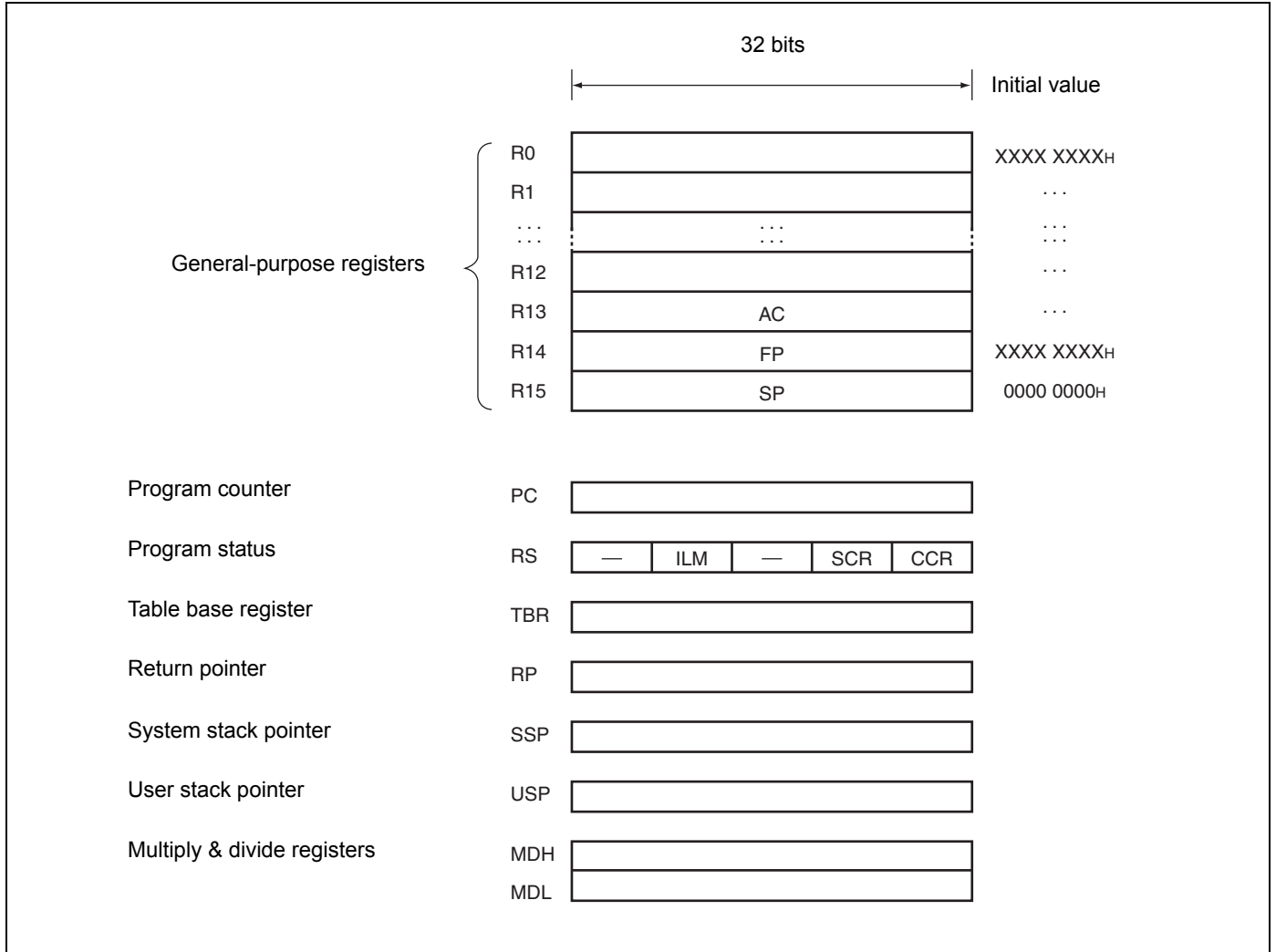

13.4.3 CCR (Condition Code Register)

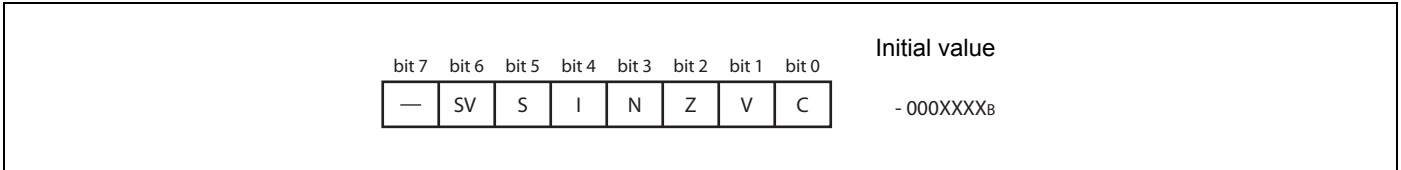

- SV : Supervisor flag
- S : Stack flag
- I : Interrupt enable flag
- N : Negative enable flag
- Z : Zero flag
- V : Overflow flag
- C : Carry flag

13.4.4 SCR (System Condition Register)

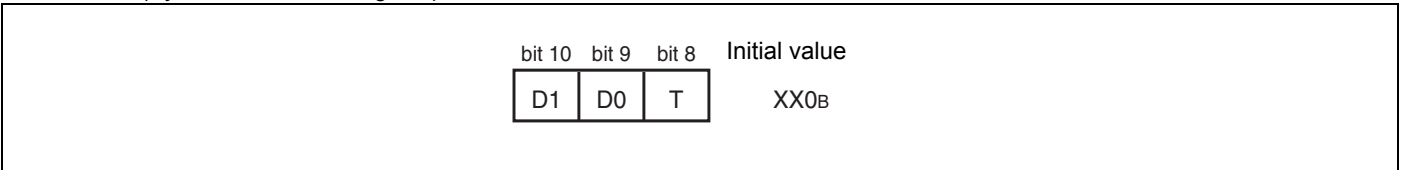

- Flag for step division (D1, D0)
This flag stores interim data during execution of step division.
- Step trace trap flag (T)
This flag indicates whether the step trace trap is enabled or disabled.
The step trace trap function is used by emulators. When an emulator is in use, it cannot be used in execution of user programs.

13.4.5 ILM (Interrupt Level Mask register)

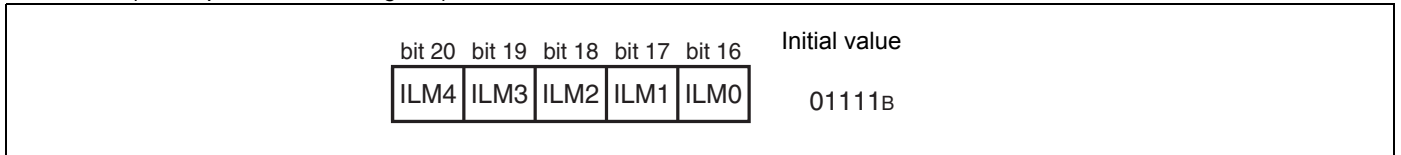

This register stores interrupt level mask values, and the values stored in ILM4 to ILM0 are used for level masking. The register is initialized to value “01111_B” at reset.

13.4.6 PC (Program Counter)

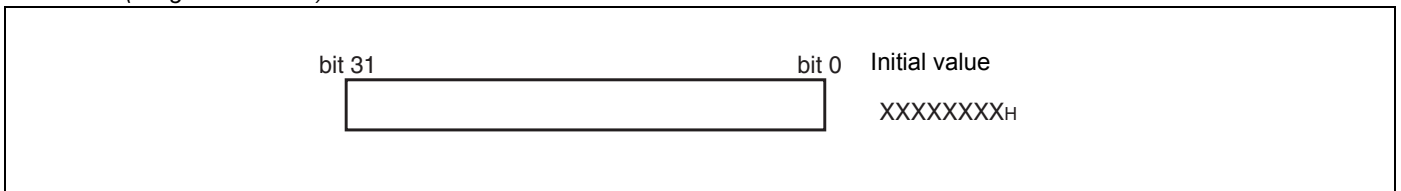

The program counter indicates the address of the instruction that is being executed. The initial value at reset is undefined.

13.4.7 TBR (Table Base Register)

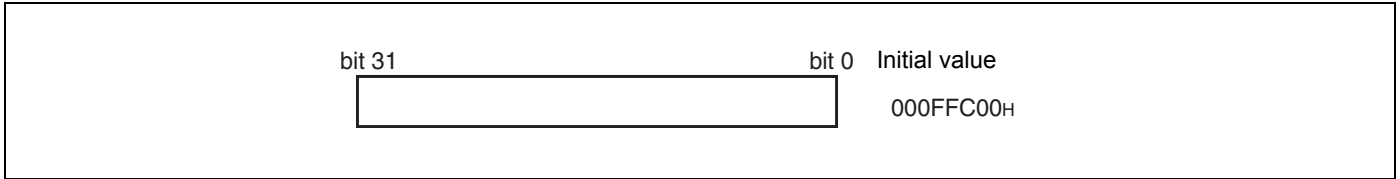

The table base register stores the starting address of the vector table used in EIT processing. The initial value at reset is 000FFC00_H.

13.4.8 RP (Return Pointer)

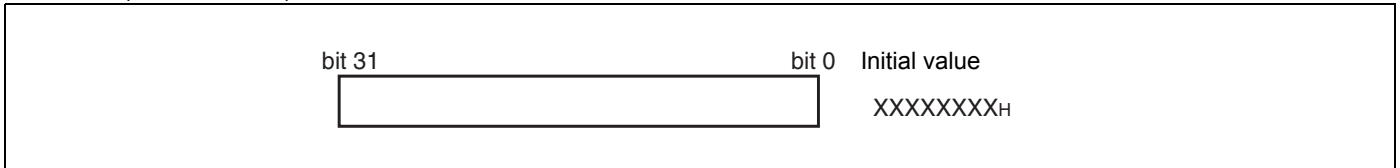

The return pointer stores the address for return from subroutines. During execution of a CALL instruction, the PC value is transferred to this RP register. During execution of a RET instruction, the contents of the RP register are transferred to PC. The initial value at reset is undefined.

13.4.9 USP (User Stack Pointer)

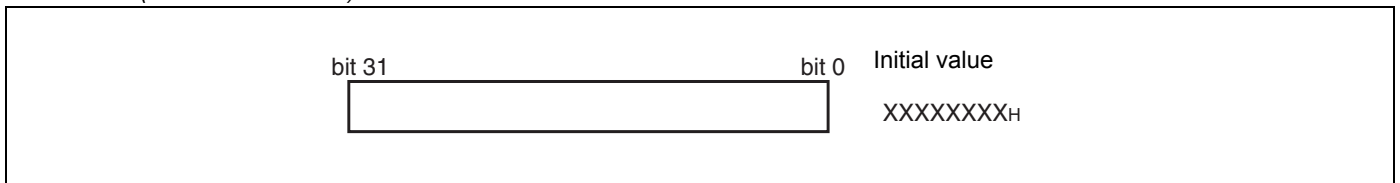

The user stack pointer, when the S flag is “1”, this register functions as the R15 register.

- The USP register can also be explicitly specified. The initial value at reset is undefined.
- This register cannot be used with RETI instructions.

13.4.10 Multiply & divide registers

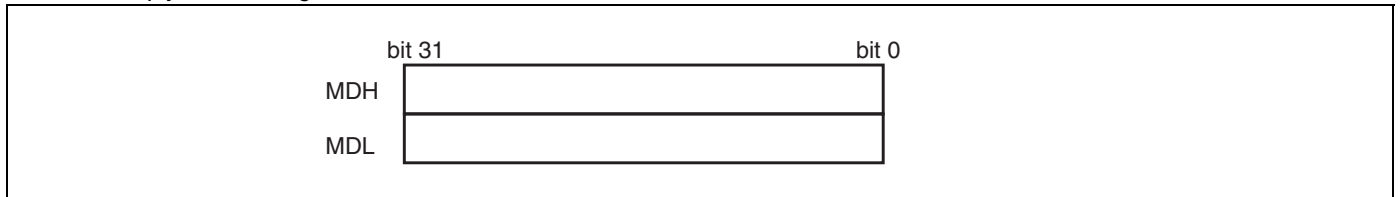

These registers are for multiplication and division, and are each 32 bits in length. The initial value at reset is undefined.

14. Embedded Program/Data Memory (Flash)

14.1 Flash features

- CY91F465PA: 544 KBytes (8×64 Kbytes + 4×8 KBytes = 4.25 Mbits)
- CY91F467PA: 1088 KBytes (16×64 Kbytes + 8×8 KBytes = 8.5 Mbits)
- Programmable wait states for read/write access
- Flash and Boot security with security vector at 0x0014:8000 - 0x0014:800F
- Boot security
- Basic specification: Same as MBM29LV400TC (except size and part of sector configuration)

14.2 Operation modes:

1. 64-bit CPU mode (available on CY91F467PA only) :
 - CPU reads and executes programs in word (32-bit) length units.
 - Flash writing is not possible.
 - Actual Flash Memory access is performed in d-word (64-bit) length units.
2. 32-bit CPU mode:
 - CPU reads and executes programs in word (32-bit) length units.
 - Actual Flash Memory access is performed in word (32-bit) length units.
3. 16-bit CPU mode:
 - CPU reads and writes in half-word (16-bit) length units.
 - Program execution from the Flash is not possible.
 - Actual Flash Memory access is performed in word (16-bit) length units.

Note: The operation mode of the flash memory can be selected using a Boot-ROM function. The function start address is 0xBF60. The parameter description is given in the Hardware Manual in chapter 54.6 "Flash Access Mode Switching".

14.3 Flash access in CPU mode

14.3.1 Flash configuration

Flash memory map CY91F465PA

Addr									
0014:FFFFh 0014:C000h	SA6 (8KB)				SA7 (8KB)				ROMS7
0014:BFFFh 0014:8000h	SA4 (8KB)				SA5 (8KB)				
0014:7FFFh 0014:4000h	SA2 (8KB)				SA3 (8KB)				
0014:3FFFh 0014:0000h	SA0 (8KB)				SA1 (8KB)				
0013:FFFFh 0012:0000h	SA22 (64KB)				SA23 (64KB)				ROMS6
0011:FFFFh 0010:0000h	SA20 (64KB)				SA21 (64KB)				
000F:FFFFh 000E:0000h	SA18 (64KB)				SA19 (64KB)				ROMS5
000D:FFFFh 000C:0000h	SA16 (64KB)				SA17 (64KB)				ROMS4
000B:FFFFh 000A:0000h	SA14 (64KB)				SA15 (64KB)				ROMS3
0009:FFFFh 0008:0000h	SA12 (64KB)				SA13 (64KB)				ROMS2
0007:FFFFh 0006:0000h	SA10 (64KB)				SA11 (64KB)				ROMS1
0005:FFFFh 0004:0000h	SA8 (64KB)				SA9 (64KB)				ROMS0
	addr+0	addr+1	addr+2	addr+3	addr+4	addr+5	addr+6	addr+7	
16bit read/write	dat[31:16]		dat[15:0]		dat[31:16]		dat[15:0]		
32bit read	dat[31:0]				dat[31:0]				
Legend	Memory not available in this area				Memory available in this area				

Flash memory map CY91F467PA

Address									
0014:FFFFh 0014:C000h	SA6 (8KB)				SA7 (8KB)				ROMS7
0014:BFFFh 0014:8000h	SA4 (8KB)				SA5 (8KB)				
0014:7FFFh 0014:4000h	SA2 (8KB)				SA3 (8KB)				
0014:3FFFh 0014:0000h	SA0 (8KB)				SA1 (8KB)				
0013:FFFFh 0012:0000h	SA22 (64KB)				SA23 (64KB)				ROMS6
0011:FFFFh 0010:0000h	SA20 (64KB)				SA21 (64KB)				
000F:FFFFh 000E:0000h	SA18 (64KB)				SA19 (64KB)				ROMS5
000D:FFFFh 000C:0000h	SA16 (64KB)				SA17 (64KB)				ROMS4
000B:FFFFh 000A:0000h	SA14 (64KB)				SA15 (64KB)				ROMS3
0009:FFFFh 0008:0000h	SA12 (64KB)				SA13 (64KB)				ROMS2
0007:FFFFh 0006:0000h	SA10 (64KB)				SA11 (64KB)				ROMS1
0005:FFFFh 0004:0000h	SA8 (64KB)				SA9 (64KB)				ROMS0
	addr+0	addr+1	addr+2	addr+3	addr+4	addr+5	addr+6	addr+7	
16bit read/write	dat[31:16]		dat[15:0]		dat[31:16]		dat[15:0]		
32bit read/write	dat[31:0]				dat[31:0]				
64bit read	dat[63:0]								

14.3.2 Flash access timing settings in CPU mode

The following tables list all settings for a given maximum Core Frequency (through the setting of CLKB or maximum clock modulation) for Flash read and write access.

Flash read timing settings (synchronous read)

Core clock (CLKB)	ATD	ALEH	EQ	WEXH	WTC	Remark
to 24 MHz	0	0	0	-	1	
to 48 MHz	0	0	1	-	2	
to 100 MHz	1	1	3	-	4	

Flash write timing settings (synchronous write)

Core clock (CLKB)	ATD	ALEH	EQ	WEXH	WTC	Remark
to 16 MHz	0	-	-	0	3	
to 32 MHz	0	-	-	0	4	
to 48 MHz	0	-	-	0	5	
to 64 MHz	1	-	-	0	6	
to 96 MHz	1	-	-	0	7	
to 100 MHz	1	-	-	1	8	

14.3.3 Address mapping from CPU to parallel programming mode

The following tables show the calculation from CPU addresses to flash macro addresses which are used in parallel programming.

Address mapping CY91F465PA

CPU Address (addr)	Condition	Flash sectors	FA (flash address) Calculation
14:8000h to 14:FFFFh	addr[2]==0	SA4, SA6 (8 Kbyte)	$FA := addr - addr\%00:4000h + (addr\%00:4000h)/2 - (addr/2)\%4 + addr\%4 - 0D:0000h$
14:8000h to 14:FFFFh	addr[2]==1	SA5, SA7 (8 Kbyte)	$FA := addr - addr\%00:4000h + (addr\%00:4000h)/2 + 00:2000h - (addr/2)\%4 + addr\%4 - 0D:0000h$
08:0000h to 13:FFFFh	addr[2]==0	SA12, SA14, SA16, SA18 (64 Kbyte)	$FA := addr - addr\%02:0000 + (addr\%02:0000h)/2 - (addr/2)\%4 + addr\%4$
08:0000h to 13:FFFFh	addr[2]==1	SA13, SA15, SA17, SA19 (64 Kbyte)	$FA := addr - addr\%02:0000h + (addr\%02:0000h)/2 + 01:0000h - (addr/2)\%4 + addr\%4$

Note: FA result is without 10:0000h offset for parallel Flash programming.

Set offset by keeping FA[20] = 1 as described in section "Parallel Flash programming mode".

Address mapping CY91F467PA

CPU Address (addr)	Condition	Flash sectors	FA (flash address) Calculation
14:0000h to 14:FFFFh	addr[2]==0	SA0, SA2, SA4, SA6 (8 Kbyte)	$FA := addr - addr\%00:4000h + (addr\%00:4000h)/2 - (addr/2)\%4 + addr\%4 - 05:0000h$
14:0000h to 14:FFFFh	addr[2]==1	SA1, SA3, SA5, SA7 (8 Kbyte)	$FA := addr - addr\%00:4000h + (addr\%00:4000h)/2 - (addr/2)\%4 + addr\%4 - 05:0000h + 00:2000h$
04:0000h to 13:FFFFh	addr[2]==0	SA8, SA10, SA12, SA14, SA16, SA18, SA20, SA22 (64 Kbyte)	$FA := addr - addr\%02:0000 + (addr\%02:0000h)/2 - (addr/2)\%4 + addr\%4 + 0C:0000h$
04:0000h to 13:FFFFh	addr[2]==1	SA9, SA11, SA13, SA15, SA17, SA19, SA21, SA23 (64 Kbyte)	$FA := addr - addr\%02:0000h + (addr\%02:0000h)/2 - (addr/2)\%4 + addr\%4 + 0C:0000h + 01:0000h$

Note: FA result is without 20:0000h offset for parallel Flash programming.

Set offset by keeping FA[21] = 1 as described in section "Parallel Flash programming mode".

14.4 Parallel Flash programming mode

14.4.1 Flash configuration in parallel Flash programming mode

Parallel Flash programming mode (MD[2:0] = 111):

CY91F465PA		CY91F467PA	
FA[20:0]		FA[21:0]	
001F:FFFh 001F:0000h	SA19 (64KB)	003F:FFFh 003F:0000h	SA23 (64KB)
001E:FFFh 001E:0000h	SA18 (64KB)	003E:FFFh 003E:0000h	SA22 (64KB)
001D:FFFh 001D:0000h	SA17 (64KB)	003D:FFFh 003D:0000h	SA21 (64KB)
001C:FFFh 001C:0000h	SA16 (64KB)	003C:FFFh 003C:0000h	SA20 (64KB)
001B:FFFh 001B:0000h	SA15 (64KB)	003B:FFFh 003B:0000h	SA19 (64KB)
001A:FFFh 001A:0000h	SA14 (64KB)	003A:FFFh 003A:0000h	SA18 (64KB)
0019:FFFh 0019:0000h	SA13 (64KB)	0039:FFFh 0039:0000h	SA17 (64KB)
0018:FFFh 0018:0000h	SA12 (64KB)	0038:FFFh 0038:0000h	SA16 (64KB)
	SA11 (64KB)	0037:FFFh 0037:0000h	SA15 (64KB)
	SA10 (64KB)	0036:FFFh 0036:0000h	SA14 (64KB)
	SA9 (64KB)	0035:FFFh 0035:0000h	SA13 (64KB)
	SA8 (64KB)	0034:FFFh 0034:0000h	SA12 (64KB)
0017:FFFh 0017:E000h	SA7 (8KB)	0033:FFFh 0033:0000h	SA11 (64KB)
0017:DFFFh 0017:C000h	SA6 (8KB)	0032:FFFh 0032:0000h	SA10 (64KB)
0017:BFFFh 0017:A000h	SA5 (8KB)	0031:FFFh 0031:0000h	SA9 (64KB)
0017:9FFFh 0017:8000h	SA4 (8KB)	0030:FFFh 0030:0000h	SA8 (64KB)
	SA3 (8KB)	002F:FFFh 002F:E000h	SA7 (8KB)
	SA2 (8KB)	002F:DFFFh 002F:C000h	SA6 (8KB)
	SA1 (8KB)	002F:BFFFh 002F:A000h	SA5 (8KB)
	SA0 (8KB)	002F:9FFFh 002F:8000h	SA4 (8KB)
		002F:7FFFh 002F:6000h	SA3 (8KB)
		002F:5FFFh 002F:4000h	SA2 (8KB)
16bit write mode	FA[1:0]=00 FA[1:0]=10 DQ[15:0] DQ[15:0]	002F:3FFFh 002F:2000h	SA1 (8KB)
		002F:1FFFh 002F:0000h	SA0 (8KB)
		16bit write mode	FA[1:0]=00 FA[1:0]=10 DQ[15:0] DQ[15:0]
	Remark: Always keep FA[0] = 0 and FA[20] = 1		
Legend	Memory available in this area		
	Memory not available in this area		
	Remark: Always keep FA[0] = 0 and FA[21] = 1		

14.4.2 Pin connections in parallel programming mode

Resetting after setting the MD[2:0] pins to [111] will halt CPU functioning. At this time, the Flash memory's interface circuit enables direct control of the Flash memory unit from external pins by directly linking some of the signals to GP-Ports. Please see table below for signal mapping.

In this mode, the Flash memory appears to the external pins as a stand-alone unit. This mode is generally set when writing/erasing using the parallel Flash programmer. In this mode, all operations of the 8.5 Mbits Flash memory's Auto Algorithms are available.

Correspondence between MBM29LV400TC and Flash Memory Control Signals

MBM29LV400TC external pins	FR-CPU mode	CY91F465PA, CY91F467PA external pins			Comment
		Flash memory mode	Normal function	Pin number	
-	INITX	-	INITX	104	
RESET	-	FRSTX	NMIX	105	
-	-	MD_2	MD_2	96	Set to '1'
-	-	MD_1	MD_1	95	Set to '1'
-	-	MD_0	MD_0	94	Set to '1'
RY/BY	FMCS:RDY bit	RY/BYX	P19_0	112	
BYTE	Internally fixed to 'H'	BYTEX	P19_2	114	
WE	Internal control signal + control via interface circuit	WEX	P18_0	118	
OE		OEX	P19_6	117	
CE		CEX	P19_5	116	
-		ATDIN	MD_3	98	Set to '0'
-		EQIN	MONCLK	97	Set to '0'
-		TESTX	P19_4	115	Set to '1'
-		RDYI	P19_1	113	Set to '0'
A-1		Internal address bus	FA0	P17_5	124
A0 to A7	FA1 to FA8		P06_0 to P06_7	6 to 13	
A8 to A15	FA9 to FA16		P05_0 to P05_7	14 to 21	
A16 to A18	FA17 to FA19		P18_1, P18_2, P18_4	119, 120, 121	
A19	FA20		P18_5	122	Set to '1' on CY91F465PA
—	FA21		P18_6	123	Not needed on CY91F465PA; Set to '1' on CY91F467PA
DQ0 to DQ7	Internal data bus	DQ0 to DQ7	P01_0 to P01_7	24 to 31	
DQ8 to DQ15		DQ8 to DQ15	P00_0 to P00_7	32 to 39	

14.5 Poweron Sequence in parallel programming mode

The flash memory can be accessed in programming mode after a certain wait time, which is needed for Security Vector fetch:

- Minimum wait time after VDD5/VDD5R power on: 2.76 ms
- Minimum wait time after INITX rising: 1.0 ms

14.6 Flash Security

14.6.1 Vector addresses

Two Flash Security Vectors (FSV1, FSV2) are located parallel to the Boot Security Vectors (BSV1, BSV2) controlling the protection functions of the Flash Security Module:

FSV1: 0x14:8000 BSV1: 0x14:8004
 FSV2: 0x14:8008 BSV2: 0x14:800C

14.6.2 Security Vector FSV1

The setting of the Flash Security Vector FSV1 is responsible for the read and write protection modes and the individual write protection of the 8 Kbytes sectors.

FSV1 (bit31 to bit16)

The setting of the Flash Security Vector FSV1 bits [31:16] is responsible for the read and write protection modes.

Explanation of the bits in the Flash Security Vector FSV1[31:16]

FSV1[31:19]	FSV1[18] Write Protection Level	FSV1[17] Write Protection	FSV1[16] Read Protection	Flash Security Mode
set all to '0'	set to '0'	set to '0'	set to '1'	Read Protection (all device modes, except INTVEC mode MD[2:0]="000")
set all to '0'	set to '0'	set to '1'	set to '0'	Write Protection (all device modes, without exception)
set all to '0'	set to '0'	set to '1'	set to '1'	Read Protection (all device modes, except INTVEC mode MD[2:0]="000") and Write Protection (all device modes)
set all to '0'	set to '1'	set to '0'	set to '1'	Read Protection (all device modes, except INTVEC mode MD[2:0]="000")
set all to '0'	set to '1'	set to '1'	set to '0'	Write Protection (all device modes, except INTVEC mode MD[2:0]="000")
set all to '0'	set to '1'	set to '1'	set to '1'	Read Protection (all device modes, except INTVEC mode MD[2:0]="000") and Write Protection (all device modes except INTVEC mode MD[2:0]="000")

FSV1 (bit15 to bit0)

The setting of the Flash Security Vector FSV1 bits [15:0] is responsible for the individual write protection of the 8 Kbytes sectors. It is only evaluated if write protection bit FSV1[17] is set.

Explanation of the bits in the Flash Security Vector FSV1[15:0]

FSV1 bit	Sector	Enable Write Protection	Disable Write Protection	Comment
FSV1[0]	SA0 (CY91F467PA)	set to "0"	set to "1"	not available
FSV1[1]	SA1 (CY91F467PA)	set to "0"	set to "1"	not available
FSV1[2]	SA2 (CY91F467PA)	set to "0"	set to "1"	not available
FSV1[3]	SA3 (CY91F467PA)	set to "0"	set to "1"	not available
FSV1[4]	SA4	set to "0"	—	Write protection is mandatory!
FSV1[5]	SA5	set to "0"	set to "1"	
FSV1[6]	SA6	set to "0"	set to "1"	
FSV1[7]	SA7	set to "0"	set to "1"	
FSV1[8]	—	set to "0"	set to "1"	not available
FSV1[9]	—	set to "0"	set to "1"	not available
FSV1[10]	—	set to "0"	set to "1"	not available
FSV1[11]	—	set to "0"	set to "1"	not available
FSV1[12]	—	set to "0"	set to "1"	not available
FSV1[13]	—	set to "0"	set to "1"	not available
FSV1[14]	—	set to "0"	set to "1"	not available
FSV1[15]	—	set to "0"	set to "1"	not available

Note: It is mandatory to always set the sector where the Flash Security Vectors FSV1 and FSV2 are located to write protected (here sector SA4). Otherwise it is possible to overwrite the Security Vector to a setting where it is possible to either read out the Flash content or manipulate data by writing.
See section "Flash access in CPU mode" for an overview about the sector organization of the Flash Memory.

14.6.3 Security Vector FSV2

The setting of the Flash Security Vector FSV2 bits [31:0] is responsible for the individual write protection of the 64 kByte sectors. It is only evaluated if write protection bit FSV1[17] is set.

Explanation of the bits in the Flash Security Vector FSV2[31:0]

FSV2 bit	Sector	Enable Write Protection	Disable Write Protection	Comment
FSV2[0]	SA8 (CY91F467PA)	set to "0"	set to "1"	
FSV2[1]	SA9 (CY91F467PA)	set to "0"	set to "1"	
FSV2[2]	SA10 (CY91F467PA)	set to "0"	set to "1"	
FSV2[3]	SA11 (CY91F467PA)	set to "0"	set to "1"	
FSV2[4]	SA12	set to "0"	set to "1"	
FSV2[5]	SA13	set to "0"	set to "1"	
FSV2[6]	SA14	set to "0"	set to "1"	
FSV2[7]	SA15	set to "0"	set to "1"	
FSV2[8]	SA16	set to "0"	set to "1"	
FSV2[9]	SA17	set to "0"	set to "1"	
FSV2[10]	SA18	set to "0"	set to "1"	
FSV2[11]	SA19	set to "0"	set to "1"	
FSV2[12]	SA20 (CY91F467PA)	set to "0"	set to "1"	
FSV2[13]	SA21 (CY91F467PA)	set to "0"	set to "1"	
FSV2[14]	SA22 (CY91F467PA)	set to "0"	set to "1"	
FSV2[15]	SA23 (CY91F467PA)	set to "0"	set to "1"	
FSV2[31:16]	—	set to "0"	set to "1"	not available

Note : See section "Flash access in CPU mode" for an overview about the sector organisation of the Flash Memory.

14.7 Notes About Flash Memory CRC Calculation

The Flash Security macro contains a feature to calculate the 32-bit checksum over addresses located in the Flash Memory address space. This feature is described in the CY91460 Series Hardware Manual, chapter 55.4.1 "Flash Security Control Register".

Additional notes are given here:

The CRC calculation runs on the internal RC clock. It is recommended to switch the RC clock frequency to 2 MHz for shortening the calculation time. However, the CPU clock (CLKB) must be faster than RC clock, otherwise the CRC calculation may not start correctly.

15. Embedded Data Flash (CY91F467PA)

CY91F467PA contains a 64 KByte internal data flash.

15.1 Data Flash Features

- CY91F467PA: 64 Kbytes (4 × 16 Kbytes + 1 × 256 bytes security sector)
- Data width of flash macro: 8 bit
- Synchronous flash interface and flash macro
- 2 access modes (direct access, command sequencer access)
- Read access 8/16/32-bit by internal sequencer hardware
- Write access 8-bit in direct access mode, 8/16/32-bit in command sequencer write mode
- Programmable wait states for read/write access
- Data Flash Security feature (read and write protection)
- CRC calculation feature
- Interrupt- and DMA request, DMA stop request

15.2 Data Flash Block Diagram

The Data Flash consists of the flash macro and interface, control, status, command sequencer and security logic. On CY91460 series devices, the Data Flash is connected to the X-Bus in parallel to the External Bus interface:

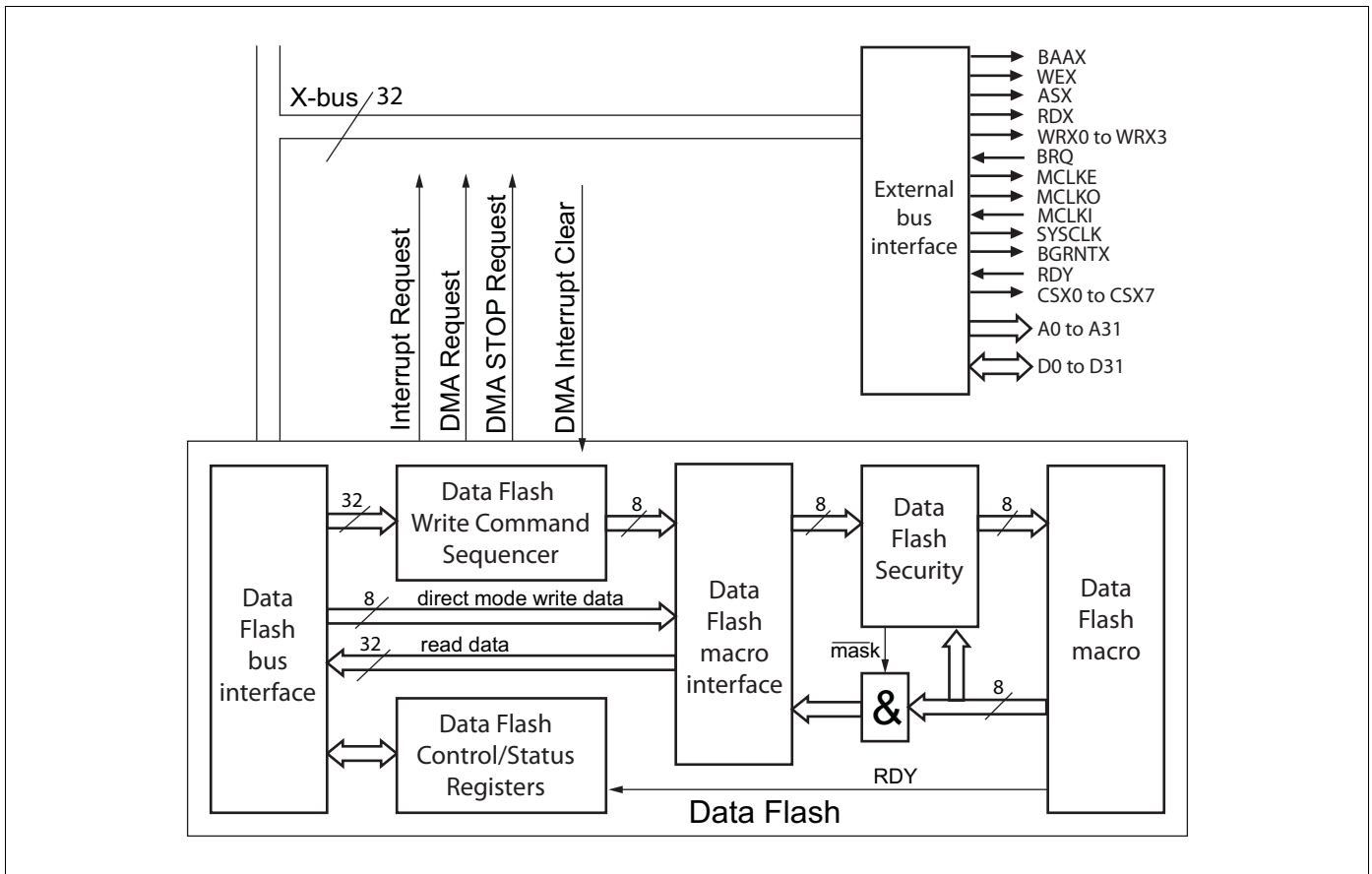

15.3 Data Flash Operation Modes

The data flash is located in the top address space of external bus area. Per **default** (after software reset RST), the data flash is **disabled** and does not accept any read/write access. The data flash can be enabled by setting the bit DFCS:FLASHEN (DFCS is the Data Flash Control/Status register).

15.3.1 Direct Access mode:

The Direct Access mode provides data flash access similar to the access of the embedded program/data flash (main flash). For write/program operations, the flash command sequences must be written by the CPU. The command sequences are the same as used for the embedded program/data flash (main flash).

- CPU reads data in byte, halfword or word (8/16/32-bit) length units, whereas 16- or 32-bit read operations are split into 2 or 4 sequential 8-bit flash macro read accesses by hardware.
- CPU writes data in byte (8-bit) width units.
- For write/program operations, the flash command sequences must be written by the CPU.
- The flash macro auto algorithms (Chip Erase, Sector Erase, Sector Erase Suspend,...) can only be activated in direct access mode.
- Direct access mode is the default mode after software reset (RST).

15.3.2 Command Sequencer Mode:

In command sequencer mode, the flash macro command sequences for data write operation are generated by hardware.

- CPU reads data in byte, halfword or word (8/16/32-bit) length units (same as in direct access mode).
- CPU writes data in byte, halfword or word (8/16/32-bit) length units using normal "store" instructions. The flash macro command sequences are generated by internal command sequencer hardware. For 16- or 32-bit write, 2 or 4 command sequences are generated, respectively.
- The data flash interface will not issue wait states after a command sequencer write operation was started. The CPU can continue working during data flash programming.
- If a command sequencer write operation is ongoing, and the CPU writes data again, this second write request is ignored! The error flag DFWS:PAERF is set in case of such a prohibited access. It is recommended to use the data flash interrupts, which indicate that the proceeding write sequence was finished and successful.
- If a command sequencer write operation is ongoing, and the CPU tries to read data, 0x00 is returned and the error flag DFWS:PAERF is set.
- The flash macro auto algorithms (Chip Erase, Sector Erase, Sector Erase Suspend,...) cannot be activated.
- Command Sequencer mode is enabled by setting the bit DFWC:WE (Data Flash Write Control register).
- After software reset (RST), the command sequencer mode is disabled.

15.3.3 Parallel Programming mode:

- The parallel programming mode works similar to the main flash memory. The function/timing of some external control lines are different.
- In parallel programming mode, it is not necessary to set the Data Flash enable bit (DFCS:FLASHEN).
- Data Flash Memory access is performed in byte (8-bit) length units.

15.4 Data Flash access in CPU mode

15.4.1 Data Flash memory map CY91F467PA

The Data Flash macro is 8 bit wide. It is located in the top address space of external bus area:

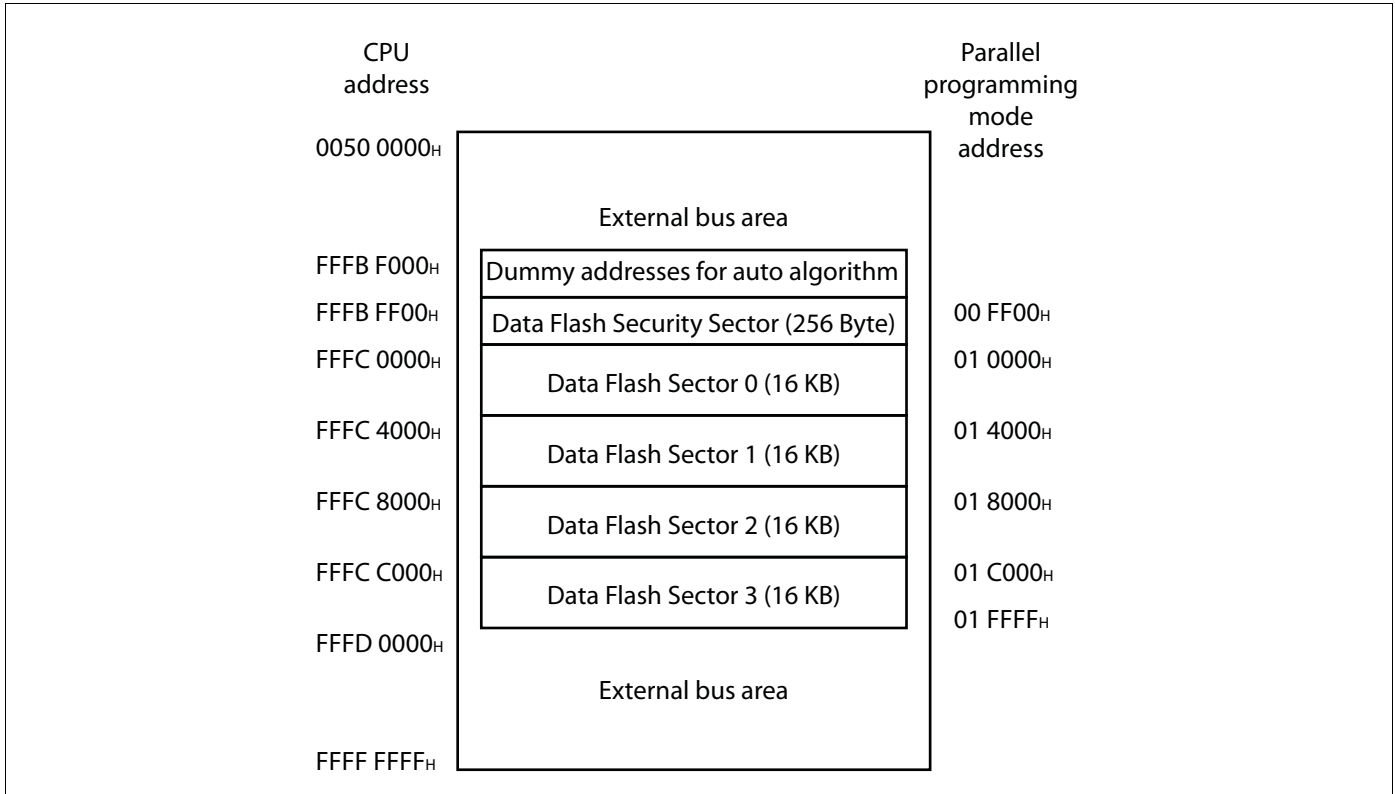

Note: The address in parallel programming mode is listed here without 10:0000h offset.
Set the offset by keeping FA[22:20] = 001 the same kind as used for programming of the main flash.

Note: The “Dummy addresses for auto algorithm” are accepted although they are located below the physical addresses of the flash macro. This address space is needed to apply correct addresses in auto algorithms.
See the example in 15.4.4 “Auto Program Algorithms”. However, toggle flags cannot be read using the dummy addresses.

15.4.2 Data Flash and External Bus

If the Data Flash is disabled (see 15.3 “Data Flash Operation Modes”), the complete address space can be used for the external bus. If the Data Flash is enabled, the user should take care that no external bus chip select area overlaps the address range of the Data Flash.

If a chip select area overlaps the Data Flash addresses, the following scenario may appear:

- Write operations will be sent to data flash and external bus in parallel. This may cause heavy problems, especially if the data flash is written in direct mode, where the CPU sends the command sequences for programming (see 15.3.1 “Direct Access mode:”).
- Read operations will return unpredictable results.

15.4.3 Flash access timing settings in CPU mode

The Data Flash can be accessed up to CLKB = 100 MHz. For timing and wait state setup, please refer to the description of the bits TMG2, TMG1, TMG0 in 15.5.1 “Data Flash Control and Status Register”.

Although the data flash is located in the address space of external bus, there is no dependency between external bus timing and data flash timing.

15.4.4 Auto Program Algorithms

The auto program algorithms can only be applied in direct access mode, while the “Program” sequence can be generated by hardware if the Command Sequencer Mode is used.

The data flash supports command sequences similar to the main flash:

Command Sequence	Bus Write Cycle	1st bus Write cycle		2nd bus Write cycle		3rd bus Write cycle		4th bus Write cycle		5th bus Write cycle		6th bus Write cycle	
		Address	Data	Address	Data	Address	Data			Address	Data	Address	Data
Read/Reset	1	XXX	F0	RA	RD								
Read/Reset	3	AA8	AA	554	55	AA8	F0	RA	RD				
Program	4	AA8	AA	554	55	AA8	A0	PA	PD				
Chip Erase	6	AA8	AA	554	55	AA8	80	AA8	AA	554	55	AA8	10
Sector Erase	6	AA8	AA	554	55	AA8	80	AA8	AA	554	55	SA	30
Sector Erase Suspend	Sector Erase Suspend by input of address “XXX” and data “B0”												
Sector Erase Resume	Sector Erase Resume by input of address “XXX” and data “30”												
Unlock Bypass set	3	AA8	AA	554	55	AA8	20						
Unlock Bypass program	2	XXX	A0	PA	PD								
Unlock Bypass Reset	2	XXX	90	XXX	F0/00								

PA: Program Address

PD: Program Data. Data to be programmed at location PA.

RA: Read Address

RD: Data to read at location RA.

SA: Sector Address (points into the sector to be erased)

It is recommended that the addresses “AA8” and “554” point to the sector which is to be programmed.

For **example**, to program a byte into sector SAS, the following sequence should be used:

AddressPA=0xFFFFBFF83 is inside sector SAS.

1. write addr=0xFFFFBFAA8 data=0xAA
2. write addr=0xFFFFBF554 data=0x55
3. write addr=0xFFFFBFAA8 data=0xA0
4. write addr=0xFFFFBFF83 =PA data=PD

Note: The address for the write sequence (1., 2., 3. write) points into the “Dummy addresses for auto algorithm” here. For polling of toggle bits, an address pointing inside the programmed sector has to be used, for example the programmed address (PA) itself.

15.4.5 Data Flash Hardware Sequence Flags (Toggle Bits)

In direct access mode, the data flash returns toggle bits shown in the following table.

In command sequencer mode, it is not necessary to read the toggle bits because they are observed by the command sequencer automatically.

Status			DQ7	DQ6	DQ5	DQ4	DQ3	DQ2	
In Progress	Embedded Program Algorithm		~DQ7	Toggle	0	0	0	1	
	Embedded Erase Algorithm (Erase Suspended Sector)	Busy to suspend	0	Toggle	0	1	1	Toggle	
		Ready to suspend				0			
	Embedded Erase Algorithm (Non-Erase Suspended Sector)	Busy to suspend	0	Toggle	0	1	1	1	
		Ready to suspend				0			
	Erase Mode Suspended	Erase Suspend Read (Erase Suspended Sector)		1	1	0	0	0	Toggle
		Erase Suspend Read (Non-Erase Suspended Sector)		Data	Data	Data	Data	Data	Data
Erase Suspend Program (Non-Erase Suspended Sector)		~DQ7	Toggle	0	0	0	1		
Exceeded Time Limits	Embedded Program Algorithm		~DQ7	Toggle	1	0	0	1	
	Embedded Erase Algorithm		0	Toggle	1	N/A	1	N/A	
	Erase Mode Suspended	Erase Suspend Program (Non-Erase Suspended Sector)	~DQ7	Toggle	1	0	0	N/A	

Note: For polling of toggle bits, an address pointing inside the programmed sector has to be used, for example the programmed address itself. Do not use a “Dummy addresses for auto algorithm”.

15.5 Data Flash Registers

The Data Flash has the following control/status registers:

DFCS : Data Flash Control and Status Register

Address	31	30	29	28	27	26	25	24	bit
07114 _H	RDYI	TMG2	TMG1	TMG0	FLASHEN	INTE	RDYINT	RDY	
	0	1	1	1	0	0	0	1	Initial value
	R/W	R/W	R/W	R/W	R/W	R/W	R/W0	R	Attribute

DFWC : Data Flash Write Command Sequencer Control Register

Address	23	22	21	20	19	18	17	16	bit
07115 _H	-	-	-	ERINTE	FININTE	IDLINTE	IDLMAE	WE	
	x	x	x	0	0	0	0	0	Initial value
	-	-	-	R/W	R/W	R/W	R/W	R/W	Attribute

DFWS : Data Flash Write Command Sequencer Status Register

Address	15	14	13	12	11	10	9	8	bit
07116 _H	PAERF	WIERINT	WERINT	TOERINT	FININT	IDLINT	ST1	ST0	
	0	0	0	0	0	0	0	0	Initial value
	R/W0	R/W0	R/W0	R/W0	R/W0	R/W0	R	R	Attribute

DFSCR0 : Data Flash Security Control Register 0

Address	31:24	23:16	15:8	7:0	bit
07118 _H	DFSCR0[31:0]				
	1111 1111	1111 1111	1111 1111	1111 1111	Initial value
	R/W, R	R	R	R	Attribute

DFSCR1 : Data Flash Security Control Register 1

Address	31:24	23:16	15:8	7:0	bit
0711C _H	DFSCR1[31:0]				
	0 --- 0001	0000 0000	0000 0000	0000 0000	Initial value
	R, R/W	R, R/W	R, R/W	R, R/W	Attribute

15.5.1 Data Flash Control and Status Register

This section explains the Data Flash Control and Status register.

DFCS : Data Flash Control and Status register

Addr: 0x07114

31	30	29	28	27	26	25	24	bit
RDYI	TMG2	TMG1	TMG0	FLASHEN	INTE	RDYINT	RDY	
0	1	1	1	0	0	0	1	initial
R/W	R/W	R/W	R/W	R/W	R/W	R/W0	R	attribute

RDYI	Ready Inversion
0	(default) Normal flash operation
1	Setting this bit to '1' activates the RDYI input of the Flash. As a result, the RDY output of the Flash goes to '0' (used for test purposes only). Always write 0 to this bit.

- This bit is cleared by software reset (RST).
- Always write 0 to this bit.

TMG2	TMG1	TMG0	Data Flash Timing Control		
			CLKB Frequency up to	CLKB Cycles per Read Operation	CLKB Cycles per Write Operation
0	0	0	6.2 MHz	3	3
0	0	1	16.7 MHz	4	3
0	1	0	33.3 MHz	5	3
0	1	1	50 MHz	6	3
1	0	0	66.6 MHz	8	4
1	0	1	83.3 MHz	9	5
1	1	0	100 MHz	10	6
1	1	1	(default) 100 MHz	11	6

- These bits control the number of wait cycles for read and write operations.
- The bits are set to "111" by software reset (RST) and can be read and written

FLASHEN	Data Flash Enable
0	(default) Data Flash is disabled and does not accept read and write access
1	Data Flash is enabled and can be read and written depending on data flash security settings.

- This bit is cleared by software reset (RST) and can be read and written
- Before setting this bit, the user has to take care that no External Bus Chip Select area overlaps the data flash address space.

INTE	Ready Interrupt Enable
0	(default) Disable the interrupt of the RDYINT flag
1	Enable the interrupt of the RDYINT flag

- If this bit is cleared, no interrupt is generated when the RDYINT flag is set.
- If this bit is set, the interrupt by RDYINT flag is enabled.
- This bit is cleared by software reset (RST) and can be read and written.

RDYINT	Ready Interrupt Flag
0	(default) The flash macro has not entered the READY state
1	The flash macro has entered the READY state

- This bit is set after a rising edge of the RDY status line of the flash macro.
- This bit is cleared by software reset (RST) or by writing 0. Writing 1 has no effect.
- Read-modify-write operations will read 1.

RDY	Flash Macro Ready Status
0	Indicates that a program/erase command is currently executed. Only the reset and suspend commands are accepted in this state.
1	(default) Indicates that no program/erase command is currently executed. Any command can be written to the Flash.

- This bit shows the RDY status line of the flash macro after a certain response time t_{BUSY} :
 In direct access mode, t_{BUSY} is minimum 90 ns after the last write access of a program sequence.
 In write sequencer mode, the command sequencer cares about RDY signal. There is no need to poll RDY.
- This bit is read-only.

15.5.2 Data Flash Write Command Sequencer Control Register

This section explains the Data Flash Sequencer Control register

DFWC : Data Flash Write Command Sequencer Control

Addr: 0x07115

23	22	21	20	19	18	17	16	bit
-	-	-	ERINTE	FININTE	IDLINTE	IDLMAE	WE	
x	x	x	0	0	0	0	0	initial
-	-	-	R/W	R/W	R/W	R/W	R/W	attribute

- Always write 0 to the bits 7:5.

ERINTE	Error Interrupt Enable
0	(default) Disable the interrupt of the error flags
1	Enable the interrupt of the error flag

- If this bit is cleared, no interrupt is generated when a error flag (TOERINT, WERINT and WIERINT) is set.
- If this bit is set, an interrupt is generated when one of the error flags is set.
- This bit is cleared by software reset (RST) and can be read and written.

FININTE	Finish Interrupt Enable
0	(default) Disable the interrupt of the FININT flag
1	Enable the interrupt of the FININT flag

- If this bit is cleared, no interrupt is generated when the FININT flag is set.
- If this bit is set, an interrupt is generated when the FININT flag is set.
- This bit is cleared by software reset (RST) and can be read and written.

IDLINTE	Idle Interrupt Enable
0	(default) Disable the interrupt of the IDLINT flag
1	Enable the interrupt of the IDLINT flag

- If this bit is cleared, no interrupt is generated when the IDLINT flag is set.
- If this bit is set, an interrupt is generated when the IDLINT flag is set.
- This bit is cleared by software reset (RST) and can be read and written.

IDLMAE	Idle DMA Enable
0	(default) Disable the DMA transfer request
1	Enable the DMA transfer request if the IDLINT flag is set

- If this bit is cleared, no DMA transfer request is generated when the IDLINT flag is set.
- If this bit is set, an DMA transfer request is generated when the IDLINT flag is set.
- This bit is cleared by software reset (RST) and can be read and written.

WE	Write Command Sequencer Enable
0	(default) Disable the Write Command Sequencer, Data Flash operates in direct mode
1	Enable the Write Command Sequencer Mode

- This bit enables the Command Sequencer mode.
- This bit is cleared by software reset (RST) and can be read and written.

15.5.3 Data Flash Write Command Sequencer Status Register

This section explains the Data Flash Command Sequencer Status register.

DFWS : Data Flash Write Command Sequencer Status

Addr: 0x07116

15	14	13	12	11	10	9	8	bit
PAERF	WIERINT	WERINT	TOERINT	FININT	IDLINT	ST1	ST0	
0	0	0	0	0	0	0	0	initial
R/W0	R/W0	R/W0	R/W0	R/W0	R/W0	R	R	attribute

The command sequencer status flags are only set if the command sequencer is enabled (DFWC:WE=1).

PAERF	Prohibited Access Error Flag
0	(default) No prohibited access detected
1	Prohibited access detected

- This flag is set if the CPU tried to read or write into the Data Flash area while the Data Flash is accessed by the Command Sequencer.
- This flag cannot generate an interrupt.
- This bit is cleared by software reset (RST) or by writing 0. Writing 1 has no effect.
- Read-modify-write operations will read 1.

WIERINT	Write Incomplete Error Flag
0	(default) Command sequencer write operation was completed
1	Command sequencer was disabled while a write operation was ongoing

- This flag is set when the command sequencer is disabled (set DFWC:WE=0) in “not idle” state.
- If this flag is 0, it is no guarantee that the write operation was successful. Use the FININT flag!
- This flag can generate an interrupt if DFWC:ERINTE is set.
- This bit is cleared by software reset (RST) or by writing 0. Writing 1 has no effect.
- Read-modify-write operations will read 1.

WERINT	Write Error Flag
0	(default) No write error detected
1	Write operation returned error

- This flag is set after a write access returned error:
 - tried to write to an erase-suspended or write-protected sector,
 - tried to write a bit “1” although it is already “0” in flash.
- This flag can generate an interrupt if DFWC:ERINTE is set.
- This bit is cleared by software reset (RST) or by writing 0. Writing 1 has no effect.
- Read-modify-write operations will read 1.

TOERINT	Timeout Error Flag
0	(default) No timeout error detected
1	A write operation ended with timeout error

- This flag is set after a write operation ended in timeout state.
- This flag can generate an interrupt if DFWC:ERINTE is set.
- This bit is cleared by software reset (RST) or by writing 0. Writing 1 has no effect.
- Read-modify-write operations will read 1.

FININT	Command Sequence Finished Flag
0	(default) Write command was not (yet) finished successfully
1	Write command was finished successfully

- This flag is set after a command sequencer write operation was finished successfully.
- This flag can generate an interrupt if DFWC:FININTE is set.
- This bit is cleared by software reset (RST) or by writing 0. Writing 1 has no effect.
- This bit is also cleared after a DMA transfer (caused by IDLINT) was finished.
- Read-modify-write operations will read 1.

IDLINT	Command Sequencer Idle Flag
0	(default) Command sequencer is disabled or not in IDLE state
1	Command sequencer entered the IDLE state

- This flag is set after the command sequencer was enabled (set DFWC:WE=1) or entered the IDLE state after a write operation was finished.
- This flag can generate an interrupt if DFWC:INTE is set.
- This flag can generate a DMA transfer request if DFWC:IDLDMAE is set.
- This bit is cleared by software reset (RST) or by writing 0. Writing 1 has no effect.
- This bit is also cleared after a DMA transfer was finished.
- Read-modify-write operations will read 1.

ST1	ST0	Command Sequencer Status Flags
0	0	(default) Command sequencer is disabled or in IDLE state
0	1	Command sequencer is submitting the write command
1	0	Command sequencer is waiting for Flash program finish
1	1	Command sequencer was disabled in "not idle" state

- Status bit {ST1,ST0} =2'b11 show that the command sequencer was disabled in "not idle" state and direct access to Flash is not yet permitted (wait for proceeding Flash sequence to finish). Max duration of this wait can be 11 clock cycle after disabling Command Sequencer.

15.5.4 Data Flash security Control Register 0,1

Please refer to 15.8.5 "Data Flash Security Registers".

15.6 Data Flash Interrupts and DMA Access

If a command sequencer write operation is ongoing, and the CPU writes data again, this second write request is ignored! Therefore, it is recommended to use the data flash interrupts or DMA, which indicates that the write sequence is finished and successful.

15.6.1 Data Flash Interrupt Flag Overview

The Data Flash interface has 6 interrupt flags with certain relationship to the 3 output lines for interrupt / DMA request:

Interrupt Flags:

- IDLINT IDLE flag, indicates that the command sequencer has entered the IDLE state after a write sequence. This flag is also set just after the command sequencer was enabled by setting DFWC:WE.
- RDYINT READY flag, indicates that the flash macro has entered READY state.
- FININT FINISH flag, indicates that the command sequencer finished a write sequence successfully.
- TOERINT TIMEOUT Error flag, indicates that a command sequencer write sequence ended in TIMEOUT error state.
- WERINT Suspend Sector Write Error flag, indicates that there was a write request to a sector which is erase suspended or write-protected and not ready for writing.
- WIERINT Write Incomplete Error flag, indicates that the command sequencer was disabled (DFWC:WE = 0) while a write sequence was ongoing.
- PAERF Prohibited Access Error flag, indicates that the CPU tried a read or write access while a command sequencer write was ongoing. PAERF is a status flag and cannot generate an interrupt.

The following picture shows the interrupt flags and their enable bits.

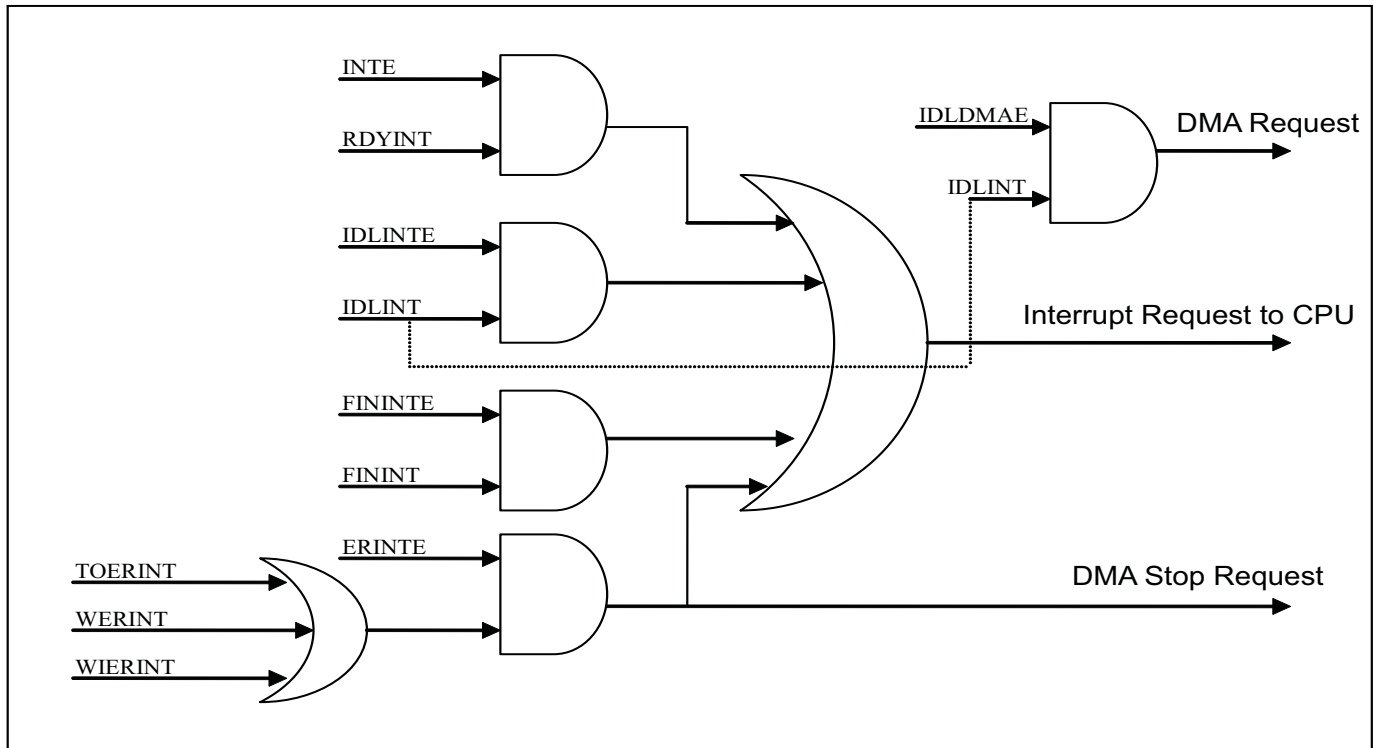

The DMA request can be activated by the IDLE flag only and has a separate enable bit (DFWC:IDLDMAE).

DMA Stop request is activated by the error flags.

The CPU interrupt can be activated by all interrupt flags.

15.7 Data Flash parallel programming mode

Note: The currently available parallel flash programmers do not support the programming of the data flash. The programmers may be updated on request. This chapter is for information only.

15.7.1 Flash configuration in parallel Flash programming mode

Parallel Flash programming mode (MD[2:0] = 111):

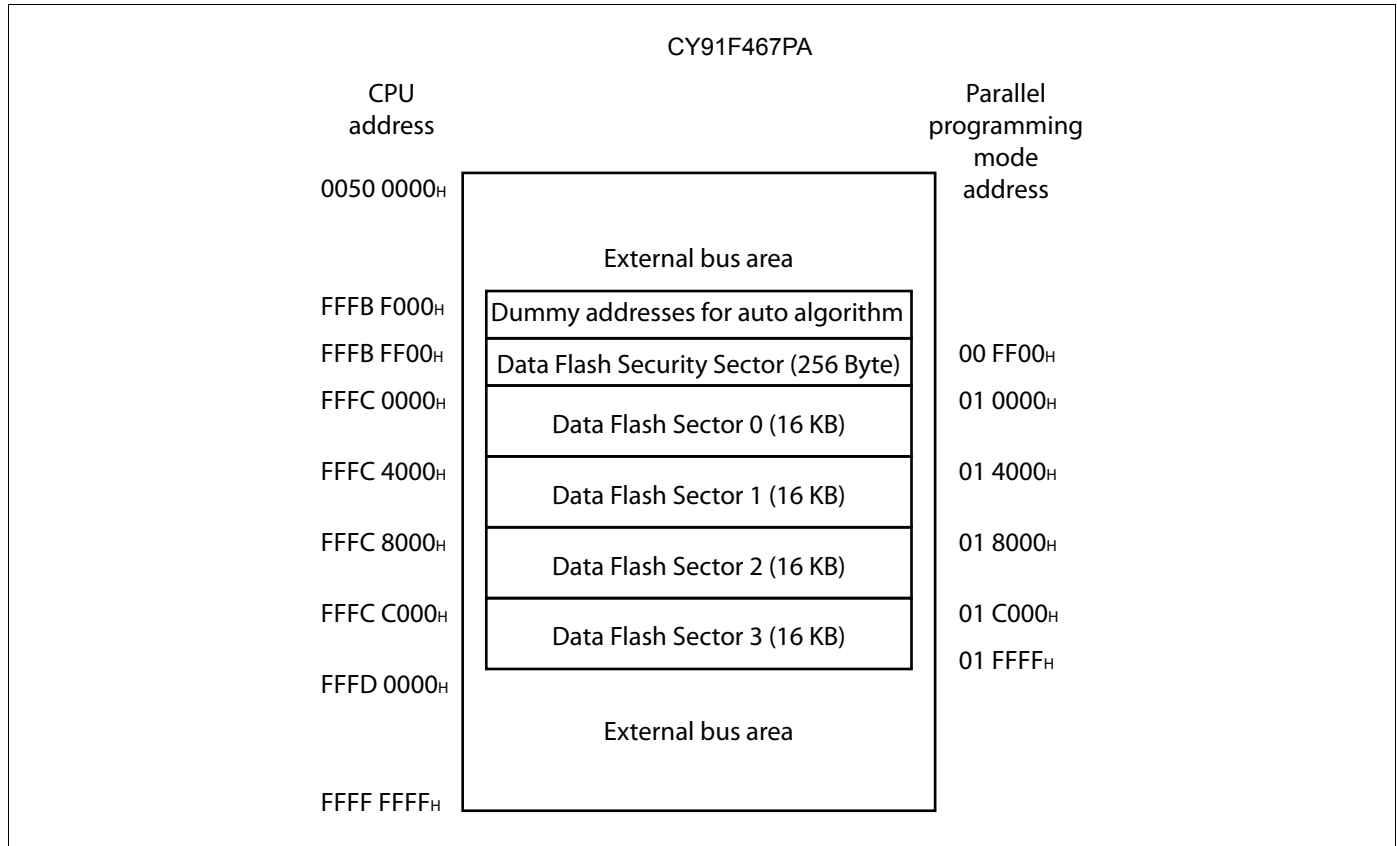

Note: The address in parallel programming mode is listed here without 10:0000h offset. Set the offset by keeping FA[22:20] = 001 the same kind as used for programming of the main flash.

Note: The “Dummy addresses for auto algorithm” are accepted although they are located below the physical addresses of the flash macro. This address space is needed to apply correct addresses in auto algorithms. See the example in 15.4.4 “Auto Program Algorithms”.

15.7.2 Address mapping from CPU to parallel programming mode

The following tables show the calculation from CPU addresses to data flash macro addresses which are used in parallel programming.

Address mapping CY91F467PA

CPU Address (addr)	Condition	Flash sectors	FA (flash address) Calculation
FFFB:FF00h to FFFC:FFFFh	-	SAS, SA0, SA1, SA2, SA3 (256 Byte + 64 Kbyte)	FA := addr - 0B:0000h

Note: FA result is without 10:0000h offset for parallel Flash programming. Set the offset by keeping FA[22:20] = 001 the same kind as used for programming of the main flash.

15.7.3 Pin connections in parallel programming mode

Resetting after setting the MD[2:0] pins to [111] will halt CPU functioning. At this time, the Flash memory's interface circuit enables direct control of the Flash memory unit from external pins by directly linking some of the signals to General Purpose Ports. Please see table below for signal mapping.

In this mode, the Data Flash memory appears to the external pins as a stand-alone unit. This mode is generally set when writing/erasing using the parallel Flash programmer. In this mode, all operations of the Data Flash memory's Auto Algorithms are available.

Correspondence between flash macro and Flash Memory Control Signal

Data Flash macro pins	FR-CPU mode	CY91F467PA external pins			Comment
—	INITX	—	INITX	104	
FRSTX	—	FRSTX	NMIX	105	
—	—	MD_2	MD_2	96	Set to '1'
—	—	MD_1	MD_1	95	Set to '1'
—	—	MD_0	MD_0	94	Set to '1'
RDY	FMCS:RDY bit	RY/BYX	P19_0	112	
FCLK		FCLK	P19_2	114	Clock input
WEX	Internal control signal + control via interface circuit	WEX	P18_0	118	
OEX		OEX	P19_6	117	
CEX		CEX	P19_5	116	
RAS		RAS	MD_3	98	
EQIN		EQIN	MONCLK	97	
LTIN		LTIN	P23_0	68	Set to '0'
—		TESTX	P19_4	115	Set to '1'
—		RDYI	P19_1	113	Set to '0'
FA0	Internal address bus	FA0	P17_5	125	
FA1 to FA8		FA1 to FA8	P06_0 to P06_7	6 to 13	
FA9 to FA16	Internal address bus	FA9 to FA16	P05_0 to P05_7	14 to 21	
—		FA17 to FA19	P18_1, P18_2, P18_4	119, 120, 121	Set to '0'
—		FA20,FA21	P18_5, P18_6	122, 123	Set to "10"
DI0 to DI7, DO0 to DO7	Internal data bus	DQ0 to DQ7	P01_0 to P01_7	24 - 31	

15.7.4 Wait time before data flash access in parallel programming mode

After power-on or the end of a Setting Initialization Request (INITX), the internal data flash security module fetches the security information. The parallel programmer cannot access the flash until the security vector fetch is finished and has to wait for the following time:

- Min waittime after VDD5/VDD5R power on : 2.9 ms
- Min waittime after INITX rising : 1.0 ms

15.8 Data Flash Security

15.8.1 Data Flash Security Operation

The data flash security protects the flash against unauthorized read and write access.

- A **read** access to protected flash will return data=0x00 without notification. There is no flag indicating that the read access was masked by data flash security module.
- A **write** access to a write-protected sector will be cancelled.
The flash macro will be put into RESET state, and the security macro will re-fetch the security information. It may take up to 600µs until the data flash can be accessed again.
In direct access mode, the toggle bits will not change and the bit DFCS:RDY will not go to low state.
In command sequencer mode, the flag DFWS:WERINT is set, indicating that the write operation was not successful.
- The only possible write operation to a protected sector is Chip Erase.
- The data flash security can be disabled by setting the external pin FSC_DISABLE = 1.
- After INIT, please wait 3 ms before accessing the data flash. This time is needed for the security vector fetch as well as internal signal synchronization. This time is valid also if FSC_DISABLE = 1.

15.8.2 Security Vectors

Two 16-bit Data Flash Security Vectors (DFSV1, DFSV2) are located in the 256 byte security sector, controlling the protection functions of the Data Flash Security module:

DFSV1[15:0]: 0xFFFFB:FF00

DFSV2[15:0]: 0xFFFFB:FF02

Address	Vectors				Block
	+0	+1	+2	+3	
FFFBFF00 _H	DFSV1[15:0]		DFSV2[15:0]		Data Flash Security Vectors

15.8.3 Security Vector DFSV1 (bit15 to bit0)

The setting of the Flash Security Vector DFSV1 is responsible for the read and write protection modes.

Explanation of the bits in the Flash Security Vector DFSV1 [15:0]

DFSV1[15:3]	DFSV1[2] Write Protection Level	DFSV1[1] Write Protection	DFSV1[0] Read Protection	Flash Security Mode
set all to "0"	set to "0"	set to "0"	set to "1"	Read Protection (all device modes, except INTVEC ¹)
set all to "0"	set to "0"	set to "1"	set to "0"	Write Protection (all device modes, without exception)
set all to "0"	set to "0"	set to "1"	set to "1"	Read Protection (all device modes, except INTVEC) and Write Protection (all device modes, without exception)
set all to "0"	set to "1"	set to "0"	set to "1"	Read Protection (all device modes, except INTVEC)
set all to "0"	set to "1"	set to "1"	set to "0"	Write Protection (all device modes, except INTVEC)
set all to "0"	set to "1"	set to "1"	set to "1"	Read Protection (all device modes, except INTVEC) and Write Protection (all device modes, except INTVEC)

1. INTVEC mode is the Internal Vector Fetch mode (MD[2:0] = "000")

Note : If Read Protection is set and the device is not in INTVEC mode and the data flash is written using the Command Sequencer write access, then the command sequencer will set the error flag because it cannot check that the flash programming was successful.

15.8.4 Security Vector DFSV2

The setting of the Flash Security Vector DFSV2 bits [15:0] is responsible for the individual write protection of the Data Flash sectors. It is only evaluated if write protection bit DFSV1 [1] is set.

Explanation of the bits in the Flash Security Vector DFSV2[15:0]

DFSV2 bit	Sector	Enable Write Protection	Disable Write Protection	Comment
DFSV2[0]	SA0	set to "0"	set to "1"	
DFSV2[1]	SA1	set to "0"	set to "1"	
DFSV2[2]	SA2	set to "0"	set to "1"	
DFSV2[3]	SA3	set to "0"	set to "1"	
DFSV2[7:4]	—	—	—	sectors not available
DFSV2[8]	SAS	set to "0"	—	write protection is mandatory!
DFSV2[15:9]	—	—	—	sectors not available

Note : It is mandatory to always set the sector where the Flash Security Vectors DFSV1 and DFSV2 are located to write protected (here sector SAS). Otherwise it is possible to overwrite the Security Vector to a setting where it is possible to either read out the Flash content or manipulate data by writing.
See section 15.4 "Data Flash access in CPU mode" for an overview about the sector organisation of the Flash Memory.

15.8.5 Data Flash Security Registers

The Data Flash Security module can be used to calculate a CRC over the Data Flash contents. And it is possible to force a security vector re-fetch by using the following registers.

DFSCR0 : Data Flash Security Control Register 0

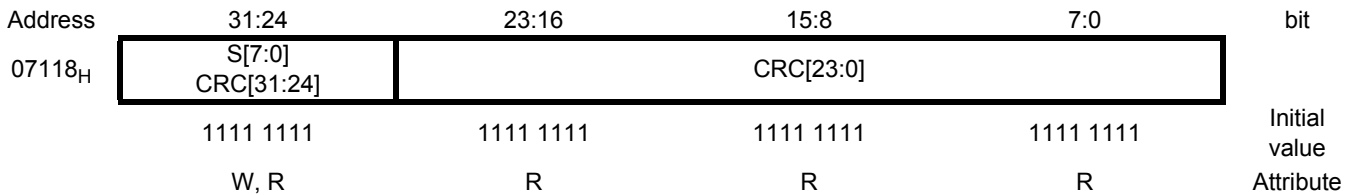

S[7:0]	Sequence Activation
0xA5 --> 0x5A	Start of a Flash Security Vector Re-Fetch Sequence (write only)
0xF0 --> 0x0F	Start of a Flash Memory CRC32 Checksum Sequence (write only)

- Continuously writing "A5_H", "5A_H" in the DFSCR0[31:24] register will start a Flash Security Vector Re-fetch sequence immediately after writing "5A_H". There is no time restrictions between "A5_H" and "5A_H", but if "A5_H" is written followed by the one other than "5A_H", it must be written "A5_H" again. If not, the Re-Fetch sequence cannot be started even if "5A_H" is written.
- Continuously writing "F0_H", "0F_H" in the DFSCR0[31:24] register will start a CRC32 checksum sequence immediately after writing "0F_H". There is no time restrictions between "F0_H" and "0F_H", but if "F0_H" is written followed by the one other than "0F_H", it must be written "F0_H" again. If not, the CRC checksum sequence cannot be started even if "0F_H" is written.
- These bits are cleared by an INIT signal from external pin (INITX) or hardware watchdog and can be written only.

Note: The Flash Security Vector Re-Fetch sequence is especially intended to be used after a chip erase command to update the security status without the need of applying an external INITX reset or after changing the status of the DFSV1 security vector.

Note: The CRC calculation runs on the internal RC clock. It is recommended to switch the RC clock frequency to 2 MHz for shortening the calculation time. However, the CPU clock (CLKB) must be faster than RC clock, otherwise the CRC calculation may not start correctly.

CRC[31:0]	CRC checksum result
	CRC checksum result (read only)

- This register contains the CRC32 checksum result after completion of the CRC32 checksum sequence (the sequence completion is indicated by DFSCR1.RDY). The CRC checksum is calculated in a standard CRC32/AAL5 algorithm with the polynomial $x^{32}+x^{26}+x^{23}+x^{22}+x^{16}+x^{12}+x^{11}+x^{10}+x^8+x^7+x^5+x^4+x^2+x+1$.
- These bits are set to 0xFFFFFFFF by an INIT signal from external pin (INITX) or hardware watchdog and can be read only.

DFSCR1 : Data Flash Security Control Register 1

Address	31:24	23:16	15:8	7:0	bit
0711C _H	SVF_RDY--- --- RDY	--- --- CSZ[3:0]	CSA[15:0]		
	0xxx xxx1	0000 0000	0000 0000	0000 0000	Initial value
	R/Wx	R, R/W	R/W	R/W	Attribute

- Bit30-25: Reserved bits. The read value is always "X".
- Bit23-20: Reserved bits. The read value is always "0".

Bit 31:

SVF_RDY	Security Vector Fetch Ready (flag)
0	The security vector has not been fetched. The data flash is protected against read and write access. Read operations to data flash return 0x00. Write operations are ignored.
1	The security vector has been done. The data flash can be accessed according to the security settings.

Bit 24:

RDY	CRC Sequence Ready (flag)
0	CRC sequence running or not yet started
1	CRC sequence ready (data in the DFSCR0 register is valid)

Bit 19-16:

CSZ[3:0]	CRC Size Mask
0000	CRC size mask is 256 Byte
0001	CRC size mask is 512 Byte
0010	CRC size mask is 1 KByte
0011	CRC size mask is 2 KByte
0100	CRC size mask is 4 KByte
0101	CRC size mask is 8 KByte
0110	CRC size mask is 16 KByte
0111	CRC size mask is 32 KByte
1000	CRC size mask is 64 KByte
1001 - 1111	Not supported

- CSZ3-0 is used as an OR-mask for the address given by CSA15-0. See address calculation below.
- These bits are cleared by an INIT signal from external pin (INITX) or hardware watchdog.

Bit 15-0

CSA[15:0]	CRC Calculation Start Address
0x00FF	CRC start address is 0x0FF00 (sector SAS start)
0x0100	CRC start address is 0x10000 (sector SA0 start)
0x0140	CRC start address is 0x14000 (sector SA1 start)

Notes: The values given above are just examples. The addresses to be written in this register are flash memory addresses like used in the flash parallel programming mode and not the mapped addresses which are used in CPU mode. See 15.7.2“Address mapping from CPU to parallel programming mode”.

- The CSA register contains the CRC start address which is aligned to 256 Byte addresses. It is only possible to calculate the CRC checksum over addresses located in the Data Flash Memory address space. Other addresses are invalid and might lead to wrong checksums.

Calculation of the CRC Start- and End-addresses

The CSZ3-0 setting is first translated into a mask value:

CSZ3-0	MASK
0000	0000_0000_0000_0000
0001	0000_0000_0000_0001
0010	0000_0000_0000_0011
0011	0000_0000_0000_0111
0100	0000_0000_0000_1111
0101	0000_0000_0001_1111
0110	0000_0000_0011_1111
0111	0000_0000_0111_1111
1000	0000_0000_1111_1111
1001-1111	and so on...

- CRC Start address = CSA[15:0] << 8 + 0x00
- CRC End address = (CSA[15:0] or MASK) << 8 + 0xFF

16. Memory Space

The FR family has 4 Gbytes of logical address space (2^{32} addresses) available to the CPU by linear access.

Direct addressing area

The following address space area is used for I/O.

This area is called direct addressing area, and the address of an operand can be specified directly in an instruction.

The size of directly addressable area depends on the length of the data being accessed as shown below.

Byte data access : 000_H to 0FF_H

Half word access : 000_H to 1FF_H

Word data access : 000_H to 3FF_H

17. Memory Maps

17.1 CY91F465PA, CY91F467PA

CY91F465PA		CY91F467PA	
00000000 _H	I/O (direct addressing area)	00000000 _H	I/O (direct addressing area)
00000400 _H	I/O	00000400 _H	I/O
00001000 _H	DMA	00001000 _H	DMA
00002000 _H		00002000 _H	
00004000 _H	Flash-Cache (8 KBytes)	00004000 _H	Flash-Cache (8 KBytes)
00006000 _H		00006000 _H	
00007000 _H	Flash memory control	00007000 _H	Flash memory control
00008000 _H		00008000 _H	
0000B000 _H	Boot ROM (4 Kbytes)	0000B000 _H	Boot ROM (4 KBytes)
0000C000 _H	CAN	0000C000 _H	CAN
0000D000 _H		0000D000 _H	
0002A000 _H	D-RAM (0 wait, 24 Kbytes)	00024000 _H	D-RAM (0 wait, 48 KBytes)
00030000 _H	ID-RAM (16 Kbytes)	00030000 _H	ID-RAM (32 KBytes)
00034000 _H		00038000 _H	
00040000 _H	External bus area	00040000 _H	Flash memory (1088 KBytes)
00080000 _H	Flash memory (512 Kbytes)	00040000 _H	
00100000 _H	External bus area	00150000 _H	External bus area
00148000 _H	Flash memory (32 Kbytes)	00180000 _H	
00150000 _H		00500000 _H	External bus area
00180000 _H	External bus area	00500000 _H	External bus area
00500000 _H	External data bus	FFFBF000 _H	Data Flash 64KB + 256Byte /
FFFFFFF _H		FFFBFF00 _H	External bus area
		FFFCFFF _H	
		FFFFFFF _H	
Note:	Access prohibited areas	Note:	Access prohibited areas

18. I/O Map

18.1 CY91F465PA, CY91F467PA

Address	Register				Block
	+ 0	+ 1	+ 2	+ 3	
000000 _H	PDR0 [R/W] XXXXXXXX	PDR1 [R/W] XXXXXXXX	PDR2 [R/W] XXXXXXXX	PDR3 [R/W] XXXXXXXX	T-unit port data register

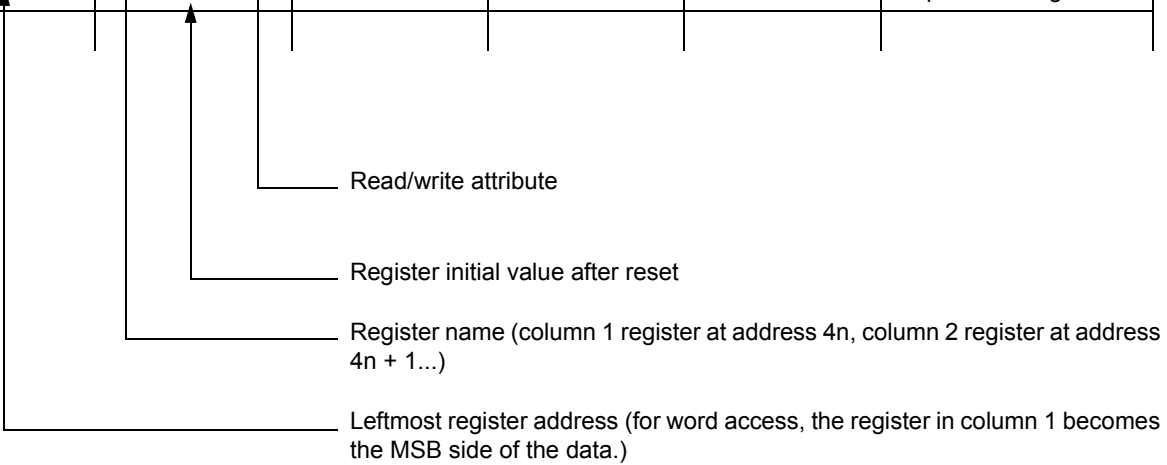

Read/write attribute

Register initial value after reset

Register name (column 1 register at address 4n, column 2 register at address 4n + 1...)

Leftmost register address (for word access, the register in column 1 becomes the MSB side of the data.)

Note : Initial values of register bits are represented as follows:

“ 1 ” : Initial value “ 1 ”

“ 0 ” : Initial value “ 0 ”

“ X ” : Initial value “ undefined ”

“ - ” : No physical register at this location

Access is barred with an undefined data access attribute.

Address	Register				Block
	+0	+1	+2	+3	
000000 _H	PDR00 [R/W] XXXXXXXX	PDR01 [R/W] XXXXXXXX	Reserved	Reserved	R-bus Port Data Register
000004 _H	Reserved	PDR05 [R/W] XXXXXXXX	PDR06 [R/W] XXXXXXXX	PDR07 [R/W] XXXXXXXX	
000008 _H	PDR08 [R/W] X - - X - -XX	PDR09 [R/W] ----- XXX	PDR10 [R/W] ---- X - XX	Reserved	
00000C _H	Reserved	Reserved	PDR14 [R/W] XXXXXXXX	PDR15 [R/W] XXXXXXXX	
000010 _H	PDR16 [R/W] XXXXXXXX	PDR17 [R/W] XXXXXXXX	PDR18 [R/W] - XXX - XXX	PDR19 [R/W] - XXX - XXX	
000014 _H	PDR20 [R/W] - XXX - XXX	PDR21 [R/W] XXXX - XXX	PDR22 [R/W] XXXXXXXX	PDR23 [R/W] XXXXXXXX	
000018 _H	PDR24 [R/W] XXXXXXXX	PDR25 [R/W] ----- XX	PDR26 [R/W] XXXXXXXX	PDR27 [R/W] XXXXXXXX	
00001C _H	PDR28 [R/W] - -XXXXX	PDR29 [R/W] XXXXXXXX	PDR30 [R/W] XXXXXXXX	Reserved	
000020 _H	PDR32 [R/W] X - - - X - - -	PDR33 [R/W] X - - - X - - -	PDR34 [R/W] XXXXXXXX	PDR35 [R/W] XXXXXXXX	
000024 _H to 00002C _H	Reserved				
000030 _H	EIRR0 [R/W] XXXXXXXX	ENIR0 [R/W] 00000000	ELVR0 [R/W] 00000000 00000000		External interrupt (INT 0 to INT 7) NMI
000034 _H	EIRR1 [R/W] XXXXXXXX	ENIR1 [R/W] 00000000	ELVR1 [R/W] 00000000 00000000		External interrupt (INT 8 to INT 15)
000038 _H	DICR [R/W] ----- 0	HRCL [R/W] 0 - - 11111	Reserved		Delay interrupt
00003C _H	Reserved				
000040 _H	SCR00 [R/W,W] 00000000	SMR00 [R/W,W] 00000000	SSR00 [R/W,R] 00001000	RDR00/TDR00 [R/W] 00000000	LIN-USART 0
000044 _H	ESCR00 [R/W] 00000X00	ECCR00 [R/W,R,W] -00000XX	Reserved		
000048 _H	SCR01 [R/W,W] 00000000	SMR01 [R/W,W] 00000000	SSR01 [R/W,R] 00001000	RDR01/TDR01 [R/W] 00000000	LIN-USART 1
00004C _H	ESCR01 [R/W] 00000X00	ECCR01 [R/W,R,W] -00000XX	Reserved		
000050 _H	SCR02 [R/W,W] 00000000	SMR02 [R/W,W] 00000000	SSR02 [R/W,R] 00001000	RDR02/TDR02 [R/W] 00000000	LIN-USART 2
000054 _H	ESCR02 [R/W] 00000X00	ECCR02 [R/W,R,W] -00000XX	Reserved		

Address	Register				Block
	+0	+1	+2	+3	
000058 _H	SCR03 [R/W,W] 00000000	SMR03 [R/W,W] 00000000	SSR03 [R/W,R] 00001000	RDR03/TDR02 [R/W] 00000000	LIN-USART 3
00005C _H	ESCR03 [R/W] 0000X00	ECCR03 [R/W,R,W] -0000XX	Reserved		
000060 _H	SCR04 [R/W,W] 00000000	SMR04 [R/W,W] 00000000	SSR04 [R/W,R] 00001000	RDR04/TDR04 [R/W] 00000000	LIN-USART 4 with FIFO
000064 _H	ESCR04 [R/W] 0000X00	ECCR04 [R/W,R,W] -0000XX	FSR04 [R] - - - 00000	FCR04 [R/W] 0001 - 000	
000068 _H	SCR05 [R/W,W] 00000000	SMR05 [R/W,W] 00000000	SSR05 [R/W,R] 00001000	RDR05/TDR05 [R/W] 00000000	LIN-USART 5 with FIFO
00006C _H	ESCR05 [R/W] 0000X00	ECCR05 [R/W,R,W] -0000XX	FSR05 [R] - - - 00000	FCR05 [R/W] 0001 - 000	
000070 _H	SCR06 [R/W,W] 00000000	SMR06 [R/W,W] 00000000	SSR06 [R/W,R] 00001000	RDR06/TDR06 [R/W] 00000000	LIN-USART 6 with FIFO
000074 _H	ESCR06 [R/W] 0000X00	ECCR06 [R/W,R,W] -0000XX	FSR06 [R] - - - 00000	FCR06 [R/W] 0001 - 000	
000078 _H	SCR07 [R/W,W] 00000000	SMR07 [R/W,W] 00000000	SSR07 [R/W,R] 00001000	RDR07/TDR07 [R/W] 00000000	LIN-USART 7 with FIFO
00007C _H	ESCR07 [R/W] 0000X00	ECCR07 [R/W,R,W] -0000XX	FSR07 [R] - - - 00000	FCR07 [R/W] 0001 - 000	
000080 _H	BGR100 [R/W] 00000000	BGR000 [R/W] 00000000	BGR101 [R/W] 00000000	BGR001 [R/W] 00000000	Baudrate Generator LIN-USART 0 to 7
000084 _H	BGR102 [R/W] 00000000	BGR002 [R/W] 00000000	BGR103 [R/W] 00000000	BGR003 [R/W] 00000000	
000088 _H	BGR104 [R/W] 00000000	BGR004 [R/W] 00000000	BGR105 [R/W] 00000000	BGR005 [R/W] 00000000	
00008C _H	BGR106 [R/W] 00000000	BGR006 [R/W] 00000000	BGR107 [R/W] 00000000	BGR007 [R/W] 00000000	
000090 _H to 0000CC _H	Reserved				
0000D0 _H	IBCR0 [R/W] 00000000	IBSR0 [R] 00000000	ITBAH0 [R/W] - - - - - 00	ITBAL0 [R/W] 00000000	I ² C 0
0000D4 _H	ITMKH0 [R/W] 00 - - - - 11	ITMKL0 [R/W] 11111111	ISMK0 [R/W] 01111111	ISBA0 [R/W] - 0000000	
0000D8 _H	Reserved	IDAR0 [R/W] 00000000	ICCR0 [R/W] - 0011111	Reserved	

Address	Register				Block
	+0	+1	+2	+3	
0000DC _H	IBCR1 [R/W] 00000000	IBSR1 [R] 00000000	ITBAH1 [R/W] ----- 00	ITBAL1 [R/W] 00000000	I ² C 1
0000E0 _H	ITMKH1 [R/W] 00 ---- 11	ITMKL1 [R/W] 11111111	ISMK1 [R/W] 01111111	ISBA1 [R/W] - 0000000	
0000E4 _H	Reserved	IDAR1 [R/W] 00000000	ICCR1 [R/W] - 0011111	Reserved	
0000E8 _H to 0000FC _H	Reserved				
000100 _H	GCN10 [R/W] 00110010 00010000		Reserved	GCN20 [R/W] ---- 0000	PPG Control 0 to 3
000104 _H	GCN11 [R/W] 00110010 00010000		Reserved	GCN21 [R/W] ---- 0000	PPG Control 4 to 7
000108 _H	GCN12 [R/W] 00110010 00010000		Reserved	GCN22 [R/W] ---- 0000	PPG Control 8 to 11
000110 _H	PTMR00 [R] 11111111 11111111		PCSR00 [W] XXXXXXXX XXXXXXXX		PPG 0
000114 _H	PDUT00 [W] XXXXXXXX XXXXXXXX		PCNH00 [R/W] 0000000 -	PCNL00 [R/W] 000000 - 0	
000118 _H	PTMR01 [R] 11111111 11111111		PCSR01 [W] XXXXXXXX XXXXXXXX		PPG 1
00011C _H	PDUT01 [W] XXXXXXXX XXXXXXXX		PCNH01 [R/W] 0000000 -	PCNL01 [R/W] 000000 - 0	
000120 _H	PTMR02 [R] 11111111 11111111		PCSR02 [W] XXXXXXXX XXXXXXXX		PPG 2
000124 _H	PDUT02 [W] XXXXXXXX XXXXXXXX		PCNH02 [R/W] 0000000 -	PCNL02 [R/W] 000000 - 0	
000128 _H	PTMR03 [R] 11111111 11111111		PCSR03 [W] XXXXXXXX XXXXXXXX		PPG 3
00012C _H	PDUT03 [W] XXXXXXXX XXXXXXXX		PCNH03 [R/W] 0000000 -	PCNL03 [R/W] 000000 - 0	
000130 _H	PTMR04 [R] 11111111 11111111		PCSR04 [W] XXXXXXXX XXXXXXXX		PPG 4
000134 _H	PDUT04 [W] XXXXXXXX XXXXXXXX		PCNH04 [R/W] 0000000 -	PCNL04 [R/W] 000000 - 0	
000138 _H	PTMR05 [R] 11111111 11111111		PCSR05 [W] XXXXXXXX XXXXXXXX		PPG 5
00013C _H	PDUT05 [W] XXXXXXXX XXXXXXXX		PCNH05 [R/W] 0000000 -	PCNL05 [R/W] 000000 - 0	
000140 _H	PTMR06 [R] 11111111 11111111		PCSR06 [W] XXXXXXXX XXXXXXXX		PPG 6
000144 _H	PDUT06 [W] XXXXXXXX XXXXXXXX		PCNH06 [R/W] 0000000 -	PCNL06 [R/W] 000000 - 0	

Address	Register				Block
	+0	+1	+2	+3	
000148 _H	PTMR07 [R] 11111111 11111111		PCSR07 [W] XXXXXXXX XXXXXXXX		PPG 7
00014C _H	PDUT07 [W] XXXXXXXX XXXXXXXX		PCNH07 [R/W] 0000000 -	PCNL07 [R/W] 000000 - 0	
000150 _H	PTMR08 [R] 11111111 11111111		PCSR08 [W] XXXXXXXX XXXXXXXX		PPG 8
000154 _H	PDUT08 [W] XXXXXXXX XXXXXXXX		PCNH08 [R/W] 0000000 -	PCNL08 [R/W] 000000 - 0	
000158 _H	PTMR09 [R] 11111111 11111111		PCSR09 [W] XXXXXXXX XXXXXXXX		PPG 9
00015C _H	PDUT09 [W] XXXXXXXX XXXXXXXX		PCNH09 [R/W] 0000000 -	PCNL09 [R/W] 000000 - 0	
000160 _H	PTMR10 [R] 11111111 11111111		PCSR10 [W] XXXXXXXX XXXXXXXX		PPG 10
000164 _H	PDUT10 [W] XXXXXXXX XXXXXXXX		PCNH10 [R/W] 0000000 -	PCNL10 [R/W] 000000 - 0	
000168 _H	PTMR11 [R] 11111111 11111111		PCSR11 [W] XXXXXXXX XXXXXXXX		PPG 11
00016C _H	PDUT11 [W] XXXXXXXX XXXXXXXX		PCNH11 [R/W] 0000000 -	PCNL11 [R/W] 000000 - 0	
000170 _H	P0TMCSRH [R/W] - 0000000	P0TMCSRL [R/W] 01000000	P1TMCSRH [R/W] - 0000000	P1TMCSRL [R/W] 01000000	Pulse Frequency Modulator
000174 _H	P0TMRLR [W] XXXXXXXX XXXXXXXX		P0TMR [R] XXXXXXXX XXXXXXXX		
000178 _H	P1TMRLR [W] XXXXXXXX XXXXXXXX		P1TMR [R] XXXXXXXX XXXXXXXX		
00017C _H	Reserved				
000180 _H	Reserved	ICS01 [R/W] 00000000	Reserved	ICS23 [R/W] 00000000	Input Capture 0 to 3
000184 _H	IPCP0 [R] XXXXXXXX XXXXXXXX		IPCP1 [R] XXXXXXXX XXXXXXXX		
000188 _H	IPCP2 [R] XXXXXXXX XXXXXXXX		IPCP3 [R] XXXXXXXX XXXXXXXX		
00018C _H	OCS01 [R/W] --- 0 -- 00 0000 -- 00		OCS23 [R/W] --- 0 -- 00 0000 -- 00		Output Compare 0 to 3
000190 _H	OCCP0 [R/W] XXXXXXXX XXXXXXXX		OCCP1 [R/W] XXXXXXXX XXXXXXXX		
000194 _H	OCCP2 [R/W] XXXXXXXX XXXXXXXX		OCCP3 [R/W] XXXXXXXX XXXXXXXX		
000198 _H	SGCRH [R/W] 0000 -- 00	SGCRL [R/W] -- 0 -- 000	SGFR [R/W, R] XXXXXXXX XXXXXXXX		Sound Generator
00019C _H	SGAR [R/W] 00000000	Reserved	SGTR [R/W] XXXXXXXX	SGDR [R/W] XXXXXXXX	

Address	Register				Block
	+0	+1	+2	+3	
0001A0 _H	ADDERH [R/W] 00000000 00000000		ADDERL [R/W] 00000000 00000000		A/D Converter 0
0001A4	ADCS1 [R/W] 00000000	ADCS0 [R/W] 00000000	ADCR1 [R] 000000XX	ADCR0 [R] XXXXXXXXXX	
0001A8 _H	ADCT1 [R/W] 00010000	ADCT0 [R/W] 00101100	ADSCH [R/W] --- 00000	ADECH [R/W] --- 00000	
0001AC _H	Reserved				
0001B0 _H	TMRLRC0 [W] XXXXXXXXXX XXXXXXXXX		TMRC0 [R] XXXXXXXXXX XXXXXXXXX		Reload Timer 0 (PPG 0-1)
0001B4 _H	Reserved		TMCSRCH0 [R/W] --- 00000	TMCSRCL0 [R/W] 0 - 000000	
0001B8 _H	TMRLRC1 [W] XXXXXXXXXX XXXXXXXXX		TMRC1 [R] XXXXXXXXXX XXXXXXXXX		Reload Timer 1 (PPG 2-3)
0001BC _H	Reserved		TMCSRCH1 [R/W] --- 00000	TMCSRCL1 [R/W] 0 - 000000	
0001C0 _H	TMRLRC2 [W] XXXXXXXXXX XXXXXXXXX		TMRC2 [R] XXXXXXXXXX XXXXXXXXX		Reload Timer 2 (PPG 4-5)
0001C4 _H	Reserved		TMCSRCH2 [R/W] --- 00000	TMCSRCL2 [R/W] 0 - 000000	
0001C8 _H	TMRLRC3 [W] XXXXXXXXXX XXXXXXXXX		TMRC3 [R] XXXXXXXXXX XXXXXXXXX		Reload Timer 3 (PPG 6-7)
0001CC _H	Reserved		TMCSRCH3 [R/W] --- 00000	TMCSRCL3 [R/W] 0 - 000000	
0001D0 _H	TMRLRC4 [W] XXXXXXXXXX XXXXXXXXX		TMRC4 [R] XXXXXXXXXX XXXXXXXXX		Reload Timer 4 (PPG 8 to 9)
0001D4 _H	Reserved		TMCSRCH4 [R/W] --- 00000	TMCSRCL4 [R/W] 0 - 000000	
0001D8 _H	TMRLRC5 [W] XXXXXXXXXX XXXXXXXXX		TMRC5 [R] XXXXXXXXXX XXXXXXXXX		Reload Timer 5 (PPG10 to 11)
0001DC _H	Reserved		TMCSRCH5 [R/W] --- 00000	TMCSRCL5 [R/W] 0 - 000000	
0001E0 _H	TMRLRC6 [W] XXXXXXXXXX XXXXXXXXX		TMRC6 [R] XXXXXXXXXX XXXXXXXXX		Reload Timer 6 (PPG 8 to 9)
0001E4 _H	Reserved		TMCSRCH6 [R/W] --- 00000	TMCSRCL6 [R/W] 0 - 000000	
0001E8 _H	TMRLRC7 [W] XXXXXXXXXX XXXXXXXXX		TMRC7 [R] XXXXXXXXXX XXXXXXXXX		Reload Timer 7 (PPG 14 to 15)
0001EC _H	Reserved		TMCSRCH7 [R/W] --- 00000	TMCSRCL7 [R/W] 0 - 000000	

Address	Register				Block
	+0	+1	+2	+3	
0001F0 _H	TCDT0 [R/W] XXXXXXXX XXXXXXXX		Reserved	TCCS0 [R/W] 00000000	Free Running Timer 0 (ICU 0 to 1)
0001F4 _H	TCDT1 [R/W] XXXXXXXX XXXXXXXX		Reserved	TCCS1 [R/W] 00000000	Free Running Timer 1 (OCU 2 to 3)
0001F8 _H	TCDT2 [R/W] XXXXXXXX XXXXXXXX		Reserved	TCCS2 [R/W] 00000000	Free Running Timer 2 (OCU 0 to 1)
0001FC _H	TCDT3 [R/W] XXXXXXXX XXXXXXXX		Reserved	TCCS3 [R/W] 00000000	Free Running Timer 3 (OCU 2 to 3)
000200 _H	DMACA0 [R/W] 00000000 0000XXXX XXXXXXXX XXXXXXXX				DMAC
000204 _H	DMACB0 [R/W] 00000000 00000000 XXXXXXXX XXXXXXXX				
000208 _H	DMACA1 [R/W] 00000000 0000XXXX XXXXXXXX XXXXXXXX				
00020C _H	DMACB1 [R/W] 00000000 00000000 XXXXXXXX XXXXXXXX				
000210 _H	DMACA2 [R/W] 00000000 0000XXXX XXXXXXXX XXXXXXXX				
000214 _H	DMACB2 [R/W] 00000000 00000000 XXXXXXXX XXXXXXXX				
000218 _H	DMACA3 [R/W] 00000000 0000XXXX XXXXXXXX XXXXXXXX				
00021C _H	DMACB3 [R/W] 00000000 00000000 XXXXXXXX XXXXXXXX				
000220 _H	DMACA4 [R/W] 00000000 0000XXXX XXXXXXXX XXXXXXXX				
000224 _H	DMACB4 [R/W] 00000000 00000000 XXXXXXXX XXXXXXXX				
000228 _H to 00023C _H	Reserved				
000240 _H	DMACR [R/W] 00 -- 0000	Reserved			
000244 _H to 00027C _H	Reserved				
000280 _H	SCR08 [R/W,W] 00000000	SMR08 [R/W,W] 00000000	SSR08 [R/W,R] 00001000	RDR08/TDR08 [R/W] 00000000	
000284 _H	ESCR08 [R/W] 0000X00	ECCR08 [R/W,R,W] -0000XX	Reserved		

Address	Register				Block
	+0	+1	+2	+3	
000288 _H	SCR09 [R/W,W] 00000000	SMR09 [R/W,W] 00000000	SSR09 [R/W,R] 00001000	RDR09/TDR09 [R/W] 00000000	LIN-USART 9
00028C _H	ESCR09 [R/W] 0000X00	ECCR09 [R/W,R,W] -0000XX	Reserved		
000290 _H	SCR10 [R/W,W] 00000000	SMR10 [R/W,W] 00000000	SSR10 [R/W,R] 00001000	RDR10/TDR10 [R/W] 00000000	LIN-USART 10
000294 _H	ESCR10 [R/W] 0000X00	ECCR10 [R/W,R,W] -0000XX	Reserved		
000298 _H	SCR11 [R/W,W] 00000000	SMR11 [R/W,W] 00000000	SSR11 [R/W,R] 00001000	RDR11/TDR11 [R/W] 00000000	LIN-USART 11
00029C _H	ESCR11 [R/W] 0000X00	ECCR11 [R/W,R,W] -0000XX	Reserved		
0002A0 _H to 0002BC _H	Reserved				
0002C0 _H	BGR108 [R/W] 00000000	BGR008 [R/W] 00000000	BGR109 [R/W] 00000000	BGR009 [R/W] 00000000	Baudrate Generator LIN-USART 8 to 11
0002C4 _H	BGR110 [R/W] 00000000	BGR010 [R/W] 00000000	BGR111 [R/W] 00000000	BGR011 [R/W] 00000000	
0002C8 _H to 0002CC _H	Reserved				
0002D0 _H	Reserved	ICS45 [R/W] 00000000	Reserved	ICS67 [R/W] 00000000	Input Capture 4 to 7
0002D4 _H	IPCP4 [R] XXXXXXXX XXXXXXXX		IPCP5 [R] XXXXXXXX XXXXXXXX		
0002D8 _H	IPCP6 [R] XXXXXXXX XXXXXXXX		IPCP7 [R] XXXXXXXX XXXXXXXX		
0002DC _H	OCS45 [R/W] --0--00 0000--00		OCS67 [R/W] --0--00 0000--00		Output Compare 4 to 7
0002E0 _H	OCCP4 [R/W] XXXXXXXX XXXXXXXX		OCCP5 [R/W] XXXXXXXX XXXXXXXX		
0002E4 _H	OCCP6 [R/W] XXXXXXXX XXXXXXXX		OCCP7 [R/W] XXXXXXXX XXXXXXXX		
0002E8 _H to 0002EC _H	Reserved				
0002F0 _H	TCDT4 [R/W] XXXXXXXX XXXXXXXX		Reserved	TCCS4 [R/W] 00000000	Free Running Timer 4 (ICU 4 to 5)
0002F4 _H	TCDT5 [R/W] XXXXXXXX XXXXXXXX		Reserved	TCCS5 [R/W] 00000000	Free Running Timer 5 (ICU 6 to 7)

Address	Register				Block
	+0	+1	+2	+3	
0002F8 _H	TCDT6 [R/W] XXXXXXXX XXXXXXXX		Reserved	TCCS6 [R/W] 00000000	Free Running Timer 6 (OCU 4 to 5)
0002FC _H	TCDT7 [R/W] XXXXXXXX XXXXXXXX		Reserved	TCCS7 [R/W] 00000000	Free Running Timer 7 (OCU 6 to 7)
000300 _H	UDRC1 [W] 00000000	UDRC0 [W] 00000000	UDCR1 [R] 00000000	UDCR0 [R] 00000000	Up/Down Counter 0 to 1
000304 _H	UDCCH0 [R/W] 00000000	UDCCL0 [R/W] 00000000	Reserved	UDCS0 [R/W] 00000000	
000308 _H	UDCCH1 [R/W] 00000000	UDCCL1 [R/W] 00000000	Reserved	UDCS1 [R/W] 00000000	
00030C _H	Reserved				
000310 _H	UDRC3 [W] 00000000	UDRC2 [W] 00000000	UDCR3 [R] 00000000	UDCR2 [R] 00000000	Up/Down Counter 2 to 3
000314 _H	UDCCH2 [R/W] 00000000	UDCCL2 [R/W] 00000000	Reserved	UDCS2 [R/W] 00000000	
000318 _H	UDCCH3 [R/W] 00000000	UDCCL3 [R/W] 00000000	Reserved	UDCS3 [R/W] 00000000	
00031C _H	Reserved				
000320 _H	GCN13 [R/W] 00110010 00010000		Reserved	GCN23 [R/W] ---- 0000	PPG Control 12 to 15
000324 _H to 00032C _H	Reserved				
000330 _H	PTMR12 [R] 11111111 11111111		PCSR12 [W] XXXXXXXX XXXXXXXX		PPG 12
000334 _H	PDUT12 [W] XXXXXXXX XXXXXXXX		PCNH12 [R/W] 0000000 -	PCNL12 [R/W] 000000 - 0	
000338 _H	PTMR13 [R] 11111111 11111111		PCSR13 [W] XXXXXXXX XXXXXXXX		PPG 13
00033C _H	PDUT13 [W] XXXXXXXX XXXXXXXX		PCNH13 [R/W] 0000000 -	PCNL13 [R/W] 000000 - 0	
000340 _H	PTMR14 [R] 11111111 11111111		PCSR14 [W] XXXXXXXX XXXXXXXX		PPG 14
000344 _H	PDUT14 [W] XXXXXXXX XXXXXXXX		PCNH14 [R/W] 0000000 -	PCNL14 [R/W] 000000 - 0	
000348 _H	PTMR15 [R] 11111111 11111111		PCSR15 [W] XXXXXXXX XXXXXXXX		PPG 15
00034C _H	PDUT15 [W] XXXXXXXX XXXXXXXX		PCNH15 [R/W] 0000000 -	PCNL15 [R/W] 000000 - 0	

Address	Register				Block
	+0	+1	+2	+3	
000368 _H	IBCR2 [R/W] 00000000	IBSR2 [R] 00000000	ITBAH2 [R/W] ----- 00	ITBAL2 [R/W] 00000000	I ² C 2
00036C _H	ITMKH2 [R/W] 00 ---- 11	ITMKL2 [R/W] 11111111	ISMK2 [R/W] 01111111	ISBA2 [R/W] - 0000000	
000370 _H	Reserved	IDAR2 [R/W] 00000000	ICCR2 [R/W] - 0011111	Reserved	
000374 _H	IBCR3 [R/W] 00000000	IBSR3 [R] 00000000	ITBAH3 [R/W] ----- 00	ITBAL3 [R/W] 00000000	I ² C 3
000378 _H	ITMKH3 [R/W] 00 ---- 11	ITMKL3 [R/W] 11111111	ISMK3 [R/W] 01111111	ISBA3 [R/W] - 0000000	
00037C _H	Reserved	IDAR3 [R/W] 00000000	ICCR3 [R/W] - 0011111	Reserved	
000380 _H to 00038C _H	Reserved				
000390 _H	ROMS [R] 11111111 01000011		Reserved		ROM Select Register
000394 _H to 0003EC _H	Reserved				
0003F0 _H	BSD0 [W] XXXXXXXX XXXXXXXX XXXXXXXX XXXXXXXX				Bit Search Module
0003F4 _H	BSD1 [R/W] XXXXXXXX XXXXXXXX XXXXXXXX XXXXXXXX				
0003F8 _H	BSDC [W] XXXXXXXX XXXXXXXX XXXXXXXX XXXXXXXX				
0003FC _H	BSRR [R] XXXXXXXX XXXXXXXX XXXXXXXX XXXXXXXX				
000400 _H to 00043C _H	Reserved				

Address	Register				Block
	+0	+1	+2	+3	
000440 _H	ICR00 [R/W] ---11111	ICR01 [R/W] ---11111	ICR02 [R/W] ---11111	ICR03 [R/W] ---11111	Interrupt Control Unit
000444 _H	ICR04 [R/W] ---11111	ICR05 [R/W] ---11111	ICR06 [R/W] ---11111	ICR07 [R/W] ---11111	
000448 _H	ICR08 [R/W] ---11111	ICR09 [R/W] ---11111	ICR10 [R/W] ---11111	ICR11 [R/W] ---11111	
00044C _H	ICR12 [R/W] ---11111	ICR13 [R/W] ---11111	ICR14 [R/W] ---11111	ICR15 [R/W] ---11111	
000450 _H	ICR16 [R/W] ---11111	ICR17 [R/W] ---11111	ICR18 [R/W] ---11111	ICR19 [R/W] ---11111	
000454 _H	ICR20 [R/W] ---11111	ICR21 [R/W] ---11111	ICR22 [R/W] ---11111	ICR23 [R/W] ---11111	
000458 _H	ICR24 [R/W] ---11111	ICR25 [R/W] ---11111	ICR26 [R/W] ---11111	ICR27 [R/W] ---11111	
00045C _H	ICR28 [R/W] ---11111	ICR29 [R/W] ---11111	ICR30 [R/W] ---11111	ICR31 [R/W] ---11111	
000460 _H	ICR32 [R/W] ---11111	ICR33 [R/W] ---11111	ICR34 [R/W] ---11111	ICR35 [R/W] ---11111	
000464 _H	ICR36 [R/W] ---11111	ICR37 [R/W] ---11111	ICR38 [R/W] ---11111	ICR39 [R/W] ---11111	
000468 _H	ICR40 [R/W] ---11111	ICR41 [R/W] ---11111	ICR42 [R/W] ---11111	ICR43 [R/W] ---11111	
00046C _H	ICR44 [R/W] ---11111	ICR45 [R/W] ---11111	ICR46 [R/W] ---11111	ICR47 [R/W] ---11111	
000470 _H	ICR48 [R/W] ---11111	ICR49 [R/W] ---11111	ICR50 [R/W] ---11111	ICR51 [R/W] ---11111	
000474 _H	ICR52 [R/W] ---11111	ICR53 [R/W] ---11111	ICR54 [R/W] ---11111	ICR55 [R/W] ---11111	
000478 _H	ICR56 [R/W] ---11111	ICR57 [R/W] ---11111	ICR58 [R/W] ---11111	ICR59 [R/W] ---11111	
00047C _H	ICR60 [R/W] ---11111	ICR61 [R/W] ---11111	ICR62 [R/W] ---11111	ICR63 [R/W] ---11111	
000480 _H	RSRR [R/W] 10000000	STCR [R/W] 00110011	TBCR [R/W] 00XXX – 00	CTBR [W] XXXXXXXXXX	Clock Control Unit
000484 _H	CLKR [R/W] ---- 0000	WPR [W] XXXXXXXXXX	DIVR0 [R/W] 00000011	DIVR1 [R/W] 00000000	
000488 _H	Reserved				Reserved
00048C _H	PLLDIVM [R/W] --- 00000	PLLDIVN [R/W] --- 00000	PLLDIVG [R/W] --- 00000	PLLDIVG [W] 00000000	PLL Clock Gear Unit
000490 _H	PLLCTRL [R/W] ---- 0000	Reserved			
000494 _H	OSCC1 [R/W] ----- 010	OSCS1 [R/W] 00001111	OSCC2 [R/W] ----- 010	OSCS2 [R/W] 00001111	Main/Sub Oscillator Control

Address	Register				Block
	+0	+1	+2	+3	
000498 _H	PORTEN [R/W] ----- 000	Reserved	PPMUX [R/W] *1 00000000 00000000		Port Input Enable Control / PortMux Control
00049C _H	PPMUX2 [R/W] *2 -- 00 0000 -----		Reserved		PortMux Control 2 (CY91F467PA)
0004A0 _H	Reserved	WTGER [R/W] ----- 00	WTCR [R/W] 00000000 000 - 00 - 0		Real Time Clock (Watch Timer)
0004A4 _H	Reserved	WTBR [R/W] --- XXXXX XXXXXXXX XXXXXXXX			
0004A8 _H	WTHR [R/W] --- 00000	WTMR [R/W] -- 000000	WTSR [R/W] -- 000000	Reserved	
0004AC _H	CSVTR [R/W] --- 00010	CSVCR [R/W] 00011100	CSCFG [R/W] 0X000000	CMCFG [R/W] 00000000	Clock-Supervisor / Selector / Monitor
0004B0 _H	CUCR [R/W] ----- 0 -- 00		CUTD [R/W] 10000000 00000000		Calibration Unit of Sub Oscillation
0004B4 _H	CUTR1 [R] ----- 00000000		CUTR2 [R] 00000000 00000000		
0004B8 _H	CMPR [R/W] -- 000010 11111101		Reserved	CMCR [R/W] - 001 -- 00	Clock Modulation
0004BC _H	CMT1 [R/W] 00000000 1 --- 0000		CMT2 [R/W] -- 000000 -- 000000		
0004C0 _H	CANPRE [R/W] 0 --- 0000	CANCKD [R/W] ---- 0000 *3	Reserved	Reserved	CAN Clock Control
0004C4 _H	LVSEL [R/W] 00000111	LVDET [R/W] 0000 0 - 00	HWWDE [R/W] ----- 00	HWWD [R/W,W] 00011000	LV Detection / Hardware-Watchdog
0004C8 _H	OSCRH [R/W] 000 -- 001	OSCR [R/W] ----- 000	WPCRH [R/W] 00 --- 000	WPCRL [R/W] ----- 00	Main-/Sub-Oscillation Stabilization Timer
0004CC _H	OSCCR [R/W] ----- 00	Reserved	REGSEL [R/W] -- 000110	REGCTR [R/W] --- 0 -- 00	Main- Oscillation Standby Control Main/Sub Regulator Control
000500 _H	GCN14 [R/W] 00110010 00010000		Reserved	GCN24 [R/W] ---- 0000	PPG Control 16 to 19
000504 _H	GCN15 [R/W] 00110010 00010000		Reserved	GCN25 [R/W] ---- 0000	PPG Control 20 to 23
000508 _H	GCN16 [R/W] 00110010 00010000		Reserved	GCN26 [R/W] ---- 0000	PPG Control 24 to 27
00050C _H	GCN17 [R/W] 00110010 00010000		Reserved	GCN27 [R/W] ---- 0000	PPG Control 28 to 31
000510 _H	PTMR16 [R] 11111111 11111111		PCSR16 [W] XXXXXXXX XXXXXXXX		PPG 16
000514 _H	PDUT16 [W] XXXXXXXX XXXXXXXX		PCNH16 [R/W] 0000000 -	PCNL16 [R/W] 000000 - 0	

Address	Register				Block
	+0	+1	+2	+3	
000518 _H	PTMR17 [R] 11111111 11111111		PCSR17 [W] XXXXXXXX XXXXXXXX		PPG 17
00051C _H	PDUT17 [W] XXXXXXXX XXXXXXXX		PCNH17 [R/W] 0000000 -	PCNL17 [R/W] 000000 - 0	
000520 _H	PTMR18 [R] 11111111 11111111		PCSR18 [W] XXXXXXXX XXXXXXXX		PPG 18
000524 _H	PDUT18 [W] XXXXXXXX XXXXXXXX		PCNH18 [R/W] 0000000 -	PCNL18 [R/W] 000000 - 0	
000528 _H	PTMR19 [R] 11111111 11111111		PCSR19 [W] XXXXXXXX XXXXXXXX		PPG 19
00052C _H	PDUT19 [W] XXXXXXXX XXXXXXXX		PCNH19 [R/W] 0000000 -	PCNL19 [R/W] 000000 - 0	
000530 _H	PTMR20 [R] 11111111 11111111		PCSR20 [W] XXXXXXXX XXXXXXXX		PPG 20
000534 _H	PDUT20 [W] XXXXXXXX XXXXXXXX		PCNH20 [R/W] 0000000 -	PCNL20 [R/W] 000000 - 0	
000538 _H	PTMR21 [R] 11111111 11111111		PCSR21 [W] XXXXXXXX XXXXXXXX		PPG 21
00053C _H	PDUT21 [W] XXXXXXXX XXXXXXXX		PCNH21 [R/W] 0000000 -	PCNL21 [R/W] 000000 - 0	
000540 _H	PTMR22 [R] 11111111 11111111		PCSR22 [W] XXXXXXXX XXXXXXXX		PPG 22
000544 _H	PDUT22 [W] XXXXXXXX XXXXXXXX		PCNH22 [R/W] 0000000 -	PCNL22 [R/W] 000000 - 0	
000548 _H	PTMR23 [R] 11111111 11111111		PCSR23 [W] XXXXXXXX XXXXXXXX		PPG 23
00054C _H	PDUT23 [W] XXXXXXXX XXXXXXXX		PCNH23 [R/W] 0000000 -	PCNL23 [R/W] 000000 - 0	
000550 _H	PTMR24 [R] 11111111 11111111		PCSR24 [W] XXXXXXXX XXXXXXXX		PPG 24
000554 _H	PDUT24 [W] XXXXXXXX XXXXXXXX		PCNH24 [R/W] 0000000 -	PCNL24 [R/W] 000000 - 0	
000558 _H	PTMR25 [R] 11111111 11111111		PCSR25 [W] XXXXXXXX XXXXXXXX		PPG 25
00055C _H	PDUT25 [W] XXXXXXXX XXXXXXXX		PCNH25 [R/W] 0000000 -	PCNL25 [R/W] 000000 - 0	
000560 _H	PTMR26 [R] 11111111 11111111		PCSR26 [W] XXXXXXXX XXXXXXXX		PPG 26
000564 _H	PDUT26 [W] XXXXXXXX XXXXXXXX		PCNH26 [R/W] 0000000 -	PCNL26 [R/W] 000000 - 0	
000568 _H	PTMR27 [R] 11111111 11111111		PCSR27 [W] XXXXXXXX XXXXXXXX		PPG 27
00056C _H	PDUT27 [W] XXXXXXXX XXXXXXXX		PCNH27 [R/W] 0000000 -	PCNL27 [R/W] 000000 - 0	

Address	Register				Block
	+0	+1	+2	+3	
000570 _H	PTMR28 [R] 11111111 11111111		PCSR28 [W] XXXXXXXX XXXXXXXX		PPG 28
000574 _H	PDUT28 [W] XXXXXXXX XXXXXXXX		PCNH28 [R/W] 0000000 -	PCNL28 [R/W] 000000 - 0	
000578 _H	PTMR29 [R] 11111111 11111111		PCSR29 [W] XXXXXXXX XXXXXXXX		PPG 29
00057C _H	PDUT29 [W] XXXXXXXX XXXXXXXX		PCNH29 [R/W] 0000000 -	PCNL29 [R/W] 000000 - 0	
000580 _H	PTMR30 [R] 11111111 11111111		PCSR30 [W] XXXXXXXX XXXXXXXX		PPG 30
000584 _H	PDUT30 [W] XXXXXXXX XXXXXXXX		PCNH30 [R/W] 0000000 -	PCNL30 [R/W] 000000 - 0	
000588 _H	PTMR31 [R] 11111111 11111111		PCSR31 [W] XXXXXXXX XXXXXXXX		PPG 31
00058C _H	PDUT31 [W] XXXXXXXX XXXXXXXX		PCNH31 [R/W] 0000000 -	PCNL31 [R/W] 000000 - 0	
000590 _H	TMRLR8 [W] XXXXXXXX XXXXXXXX		TMR8 [R] XXXXXXXX XXXXXXXX		Reload Timer 8 (PPG 16 to 19)
000594 _H	Reserved		TMCSRH8 [R/W] -- 000000	TMCSRL8 [R/W] 0 - 000000	
000598 _H	TMRLR9 [W] XXXXXXXX XXXXXXXX		TMR9 [R] XXXXXXXX XXXXXXXX		Reload Timer 9 (PPG 16 to 19)
00059C _H	Reserved		TMCSRH9 [R/W] -- 000000	TMCSRL9 [R/W] 0 - 000000	
0005A0 _H	TMRLR10 [W] XXXXXXXX XXXXXXXX		TMR10 [R] XXXXXXXX XXXXXXXX		Reload Timer 10 (PPG 20 to 23)
0005A4 _H	Reserved		TMCSRH10 [R/W] -- 000000	TMCSRL10 [R/W] 0 - 000000	
0005A8 _H	TMRLR11 [W] XXXXXXXX XXXXXXXX		TMR11 [R] XXXXXXXX XXXXXXXX		Reload Timer 11 (PPG 20 to 23)
0005AC _H	Reserved		TMCSRH11 [R/W] -- 000000	TMCSRL11 [R/W] 0 - 000000	
0005B0 _H	TMRLR12 [W] XXXXXXXX XXXXXXXX		TMR12 [R] XXXXXXXX XXXXXXXX		Reload Timer 12 (PPG 24 to 27)
0005B4 _H	Reserved		TMCSRH12 [R/W] -- 000000	TMCSRL12 [R/W] 0 - 000000	
0005B8 _H	TMRLR13 [W] XXXXXXXX XXXXXXXX		TMR13 [R] XXXXXXXX XXXXXXXX		Reload Timer 13 (PPG 24 to 27)
0005BC _H	Reserved		TMCSRH13 [R/W] -- 000000	TMCSRL13 [R/W] 0 - 000000	

Address	Register				Block
	+0	+1	+2	+3	
0005C0 _H	TMRLR14 [W] XXXXXXXX XXXXXXXX		TMR14 [R] XXXXXXXX XXXXXXXX		Reload Timer 14 (PPG 28 to 31)
0005C4 _H	Reserved		TMCSRH14 [R/W] -- 000000	TMCSRL14 [R/W] 0 - 000000	
0005C8 _H	TMRLR15 [W] XXXXXXXX XXXXXXXX		TMR15 [R] XXXXXXXX XXXXXXXX		Reload Timer 15 (PPG 28 to 31)
0005CC _H	Reserved		TMCSRH15 [R/W] -- 000000	TMCSRL15 [R/W] 0 - 000000	
0005D0 _H	TMR89 [R] XXXXXXXX XXXXXXXX XXXXXXXX XXXXXXXX				Reload Timers 8 + 9
0005D4 _H	TMR1011 [R] XXXXXXXX XXXXXXXX XXXXXXXX XXXXXXXX				Reload Timers 10 + 11
0005D8 _H	TMR1213 [R] XXXXXXXX XXXXXXXX XXXXXXXX XXXXXXXX				Reload Timers 12 + 13
0005DC _H	TMR1415 [R] XXXXXXXX XXXXXXXX XXXXXXXX XXXXXXXX				Reload Timers 14 + 15
0005E0 _H	AD1ERH [R/W] 00000000 00000000		AD1ERL [R/W] 00000000 00000000		A/D Converter 1 *4 (CY91F467PA)
0005E4 _H	AD1CS1 [R/W] 00000000	AD1CS0 [R/W] 00000000	AD1CR1 [R] 000000XX	AD1CR0 [R] XXXXXXXXXX	
0005E8 _H	AD1CT1 [R/W] 00010000	AD1CT0 [R/W] 00101100	AD1SCH [R/W] --- 00000	AD1ECH [R/W] --- 00000	
0005EC _H to 00063F _H	Reserved				

Address	Register				Block
	+0	+1	+2	+3	
000640 _H	ASR0 [R/W] 00000000 00000000		ACR0 [R/W] 1111**00 00100000 *5		External Bus Unit
000644 _H	ASR1 [R/W] XXXXXXXX XXXXXXXX		ACR1 [R/W] XXXXXXXX XXXXXXXX		
000648 _H	ASR2 [R/W] XXXXXXXX XXXXXXXX		ACR2 [R/W] XXXXXXXX XXXXXXXX		
00064C _H	ASR3 [R/W] XXXXXXXX XXXXXXXX		ACR3 [R/W] XXXXXXXX XXXXXXXX		
000650 _H	ASR4 [R/W] XXXXXXXX XXXXXXXX		ACR4 [R/W] XXXXXXXX XXXXXXXX		
000654 _H	ASR5 [R/W] XXXXXXXX XXXXXXXX		ACR5 [R/W] XXXXXXXX XXXXXXXX		
000658 _H	ASR6 [R/W] XXXXXXXX XXXXXXXX		ACR6 [R/W] XXXXXXXX XXXXXXXX		
00065C _H	ASR7 [R/W] XXXXXXXX XXXXXXXX		ACR7 [R/W] XXXXXXXX XXXXXXXX		
000660 _H	AWR0 [R/W] 01111111 11111011		AWR1 [R/W] XXXXXXXX XXXXXXXX		
000664 _H	AWR2 [R/W] XXXXXXXX XXXXXXXX		AWR3 [R/W] XXXXXXXX XXXXXXXX		
000668 _H	AWR4 [R/W] XXXXXXXX XXXXXXXX		AWR5 [R/W] XXXXXXXX XXXXXXXX		
00066C _H	AWR6 [R/W] XXXXXXXX XXXXXXXX		AWR7 [R/W] XXXXXXXX XXXXXXXX		
000670 _H	MCRA [R/W] XXXXXXXX	MCRB [R/W] XXXXXXXX	Reserved		
000674 _H	Reserved				
000678 _H	IORW0 [R/W] XXXXXXXX	IORW1 [R/W] XXXXXXXX	IORW2 [R/W] XXXXXXXX	Reserved	
00067C _H	Reserved				
000680 _H	CSER [R/W] 00000001	CHER [R/W] 11111111	Reserved	TCR [R/W] 0000**** *6	
000684 _H	RCRH [R/W] 00XXXXXX	RCRL [R/W] XXXX0XXX	Reserved		
000688 _H	RCO0H0 [R/W] 11111111	RCO0L0 [R/W] 0000 0000	RCO0H1 [R/W] 11111111	RCO0L1 [R/W] 0000 0000	A/D Converter 0 Range Comparator *7 (CY91F467PA)
00068C _H	RCO0H2 [R/W] 11111111	RCO0L2 [R/W] 0000 0000	RCO0H3 [R/W] 11111111	RCO0L3 [R/W] 0000 0000	
000690 _H	RCO0IRS [R/W] 00000000 00000000 00000000 00000000				
000694 _H	RCO0OF [R] 00000000 00000000 00000000 00000000				
000698 _H	RCO0INT [R/W0] 00000000 00000000 00000000 00000000				
00069C _H	reserved				

Address	Register				Block
	+0	+1	+2	+3	
0006A0 _H	AD0CC0 [R/W] 0000 0000	AD0CC1 [R/W] 0000 0000	AD0CC2 [R/W] 0000 0000	AD0CC3 [R/W] 0000 0000	A/D Converter 0 Channel Control (CY91F467PA)
0006A4 _H	AD0CC4 [R/W] 0000 0000	AD0CC5 [R/W] 0000 0000	AD0CC6 [R/W] 0000 0000	AD0CC7 [R/W] 0000 0000	
0006A8 _H	AD0CC8 [R/W] 0000 0000	AD0CC9 [R/W] 0000 0000	AD0CC10 [R/W] 0000 0000	AD0CC11 [R/W] 0000 0000	
0006AC _H	AD0CC12 [R/W] 0000 0000	AD0CC13 [R/W] 0000 0000	AD0CC14 [R/W] 0000 0000	AD0CC15 [R/W] 0000 0000	
0006B0 _H	AD0CS2 [RW] 0000 - - 00	reserved			A/D Converter 0 Control register 2 (CY91F467PA)
0006B4 _H	RCO1H0 [R/W] 11111111	RCO1L0 [R/W] 0000 0000	RCO1H1 [R/W] 11111111	RCO1L1 [R/W] 0000 0000	A/D Converter 1 Range Comparator (CY91F467PA)
0006B8 _H	RCO1H2 [R/W] 11111111	RCO1L2 [R/W] 0000 0000	RCO1H3 [R/W] 11111111	RCO1L3 [R/W] 0000 0000	
0006BC _H	RCO1IRS [R/W] 00000000 00000000 00000000 00000000				
0006C0 _H	RCO1OF [R] 00000000 00000000 00000000 00000000				
0006C4 _H	RCO1INT [R/W0] 00000000 00000000 00000000 00000000				
0006C8 _H	reserved				
0006CC _H	AD1CC0 [R/W] 0000 0000	AD1CC1 [R/W] 0000 0000	AD1CC2 [R/W] 0000 0000	AD1CC3 [R/W] 0000 0000	
0006D0 _H	AD1CC4 [R/W] 0000 0000	AD1CC5 [R/W] 0000 0000	AD1CC6 [R/W] 0000 0000	AD1CC7 [R/W] 0000 0000	A/D Converter 1 Channel Control (CY91F467PA)
0006D4 _H	AD1CC8 [R/W] 0000 0000	AD1CC9 [R/W] 0000 0000	AD1CC10 [R/W] 0000 0000	AD1CC11 [R/W] 0000 0000	
0006D8 _H	AD1CC12 [R/W] 0000 0000	AD1CC13 [R/W] 0000 0000	AD1CC14 [R/W] 0000 0000	AD1CC15 [R/W] 0000 0000	
0006DC _H	AD1CS2 [RW] 0000 - - 00	reserved			A/D Converter 1 Control register 2 (CY91F467PA)

Address	Register				Block
	+0	+1	+2	+3	
0006E0 _H	ADC0D0 [R] ----- XX XXXXXXXXX		ADC0D1 [R] ----- XX XXXXXXXXX		A/D Converter 0 Channel Data registers *8 (CY91F467PA)
0006E4 _H	ADC0D2 [R] ----- XX XXXXXXXXX		ADC0D3 [R] ----- XX XXXXXXXXX		
0006E8 _H	ADC0D4 [R] ----- XX XXXXXXXXX		ADC0D5 [R] ----- XX XXXXXXXXX		
0006EC _H	ADC0D6 [R] ----- XX XXXXXXXXX		ADC0D7 [R] ----- XX XXXXXXXXX		
0006F0 _H	ADC0D8 [R] ----- XX XXXXXXXXX		ADC0D9 [R] ----- XX XXXXXXXXX		
0006F4 _H	ADC0D10 [R] ----- XX XXXXXXXXX		ADC0D11 [R] ----- XX XXXXXXXXX		
0006F8 _H	ADC0D12 [R] ----- XX XXXXXXXXX		ADC0D13 [R] ----- XX XXXXXXXXX		
0006FC _H	ADC0D14 [R] ----- XX XXXXXXXXX		ADC0D15 [R] ----- XX XXXXXXXXX		
000700 _H	ADC0D16 [R] ----- XX XXXXXXXXX		ADC0D17 [R] ----- XX XXXXXXXXX		
000704 _H	ADC0D18 [R] ----- XX XXXXXXXXX		ADC0D19 [R] ----- XX XXXXXXXXX		
000708 _H	ADC0D20 [R] ----- XX XXXXXXXXX		ADC0D21 [R] ----- XX XXXXXXXXX		
00070C _H	ADC0D22 [R] ----- XX XXXXXXXXX		ADC0D23 [R] ----- XX XXXXXXXXX		
000710 _H	ADC0D24 [R] ----- XX XXXXXXXXX		ADC0D25 [R] ----- XX XXXXXXXXX		
000714 _H	ADC0D26 [R] ----- XX XXXXXXXXX		ADC0D27 [R] ----- XX XXXXXXXXX		
000718 _H	ADC0D28 [R] ----- XX XXXXXXXXX		ADC0D29 [R] ----- XX XXXXXXXXX		
00071C _H	ADC0D30 [R] ----- XX XXXXXXXXX		ADC0D31 [R] ----- XX XXXXXXXXX		

Address	Register				Block
	+0	+1	+2	+3	
000720 _H	ADC1D0 [R] ----- XX XXXXXXXX		ADC1D1 [R] ----- XX XXXXXXXX		A/D Converter 1 Channel Data registers (CY91F467PA)
000724 _H	ADC1D2 [R] ----- XX XXXXXXXX		ADC1D3 [R] ----- XX XXXXXXXX		
000728 _H	ADC1D4 [R] ----- XX XXXXXXXX		ADC1D5 [R] ----- XX XXXXXXXX		
00072C _H	ADC1D6 [R] ----- XX XXXXXXXX		ADC1D7 [R] ----- XX XXXXXXXX		
000730 _H	ADC1D8 [R] ----- XX XXXXXXXX		ADC1D9 [R] ----- XX XXXXXXXX		
000734 _H	ADC1D10 [R] ----- XX XXXXXXXX		ADC1D11 [R] ----- XX XXXXXXXX		
000738 _H	ADC1D12 [R] ----- XX XXXXXXXX		ADC1D13 [R] ----- XX XXXXXXXX		
00073C _H	ADC1D14 [R] ----- XX XXXXXXXX		ADC1D015 [R] ----- XX XXXXXXXX		
000740 _H	ADC1D16 [R] ----- XX XXXXXXXX		ADC1D17 [R] ----- XX XXXXXXXX		
000744 _H	ADC1D18 [R] ----- XX XXXXXXXX		ADC1D19 [R] ----- XX XXXXXXXX		
000748 _H	ADC1D20 [R] ----- XX XXXXXXXX		ADC1D21 [R] ----- XX XXXXXXXX		
00074C _H	ADC1D22 [R] ----- XX XXXXXXXX		ADC1D23 [R] ----- XX XXXXXXXX		
000750 _H	ADC1D24 [R] ----- XX XXXXXXXX		ADC1D25 [R] ----- XX XXXXXXXX		
000754 _H	ADC1D26 [R] ----- XX XXXXXXXX		ADC1D27 [R] ----- XX XXXXXXXX		
000758 _H	ADC1D28 [R] ----- XX XXXXXXXX		ADC1D29 [R] ----- XX XXXXXXXX		
00075C _H	ADC1D30 [R] ----- XX XXXXXXXX		ADC1D31 [R] ----- XX XXXXXXXX		
000760 _H to 0007F8 _H	Reserved				
0007FC _H	Reserved	MODR [W] XXXXXXXX	Reserved	Reserved	Mode Register
000800 _H to 000BFC _H	Reserved				
000C00 _H	reserved			IOS [R/W] *9 -----10	I-Unit
000C04 _H to 000CFC _H	reserved				

Address	Register				Block
	+0	+1	+2	+3	
000D00 _H	PDRD00 [R] XXXXXXXX	PDRD01 [R] XXXXXXXX	Reserved	Reserved	R-bus Port Data Direct Read Register
000D04 _H	Reserved	PDRD05 [R] XXXXXXXX	PDRD06 [R] XXXXXXXX	PDRD07 [R] XXXXXXXX	
000D08 _H	PDRD08 [R] X - X - XX	PDRD09 [R] ----- XXX	PDRD10 [R] ---- X - XX	Reserved	
000D0C _H	Reserved	Reserved	PDRD14 [R] XXXXXXXX	PDRD15 [R] XXXXXXXX	
000D10 _H	PDRD16 [R] XXXXXXXX	PDRD17 [R] XXXXXXXX	PDRD18 [R] - XXX - XXX	PDRD19 [R] - XXX - XXX	
000D14 _H	PDRD20 [R] - XXX - XXX	PDRD21 [R] XXXX - XXX	PDRD22 [R] XXXXXXXX	PDRD23 [R] XXXXXXXX	
000D18 _H	PDRD24 [R] XXXXXXXX	PDRD25 [R] ----- XX	PDRD26 [R] XXXXXXXX	PDRD27 [R] XXXXXXXX	
000D1C _H	PDRD28 [R] XXXXXXXX	PDRD29 [R] XXXXXXXX	PDRD30 [R] XXXXXXXX	Reserved	
000D20 _H	PDRD32 [R] X --- X ---	PDRD33 [R] X --- X ---	PDRD34 [R] XXXXXXXX	PDRD35 [R] XXXXXXXX	
000D24 _H to 000D3C _H	Reserved				
000D40 _H	DDR00 [R/W] 00000000	DDR01 [R/W] 00000000	Reserved	Reserved	R-bus Port Direction Register
000D44 _H	Reserved	DDR05 [R/W] 00000000	DDR06 [R/W] 00000000	DDR07 [R/W] 00000000	
000D48 _H	DDR08 [R/W] 0 -- 0 -- 00	DDR09 [R/W] ----- 000	DDR10 [R/W] ---- 0 - 00	Reserved	
000D4C _H	Reserved	Reserved	DDR14 [R/W] 00000000	DDR15 [R/W] 00000000	
000D50 _H	DDR16 [R/W] 00000000	DDR17 [R/W] 00000000	DDR18 [R/W] - 000 - 000	DDR19 [R/W] - 000 - 000	
000D54 _H	DDR20 [R/W] - 000 - 000	DDR21 [R/W] 0000 - 000	DDR22 [R/W] 00000000	DDR23 [R/W] 00000000	
000D58 _H	DDR24 [R/W] 00000000	DDR25 [R/W] ----- 00	DDR26 [R/W] 00000000	DDR27 [R/W] 00000000	
000D5C _H	DDR28 [R/W] 00000000	DDR29 [R/W] 00000000	DDR30 [R/W] 00000000	Reserved	
000D60 _H	DDR32 [R/W] 0 --- 0 ---	DDR33 [R/W] 0 --- 0 ---	DDR34 [R/W] 00000000	DDR35 [R/W] 00000000	
000D64 _H to 000D7C _H	Reserved				

Address	Register				Block
	+0	+1	+2	+3	
000D80 _H	PFR00 [R/W] 00000000 *10	PFR01 [R/W] 00000000	Reserved	Reserved	R-bus Port Function Register
000D84 _H	Reserved	PFR05 [R/W] 00000000	PFR06 [R/W] 00000000	PFR07 [R/W] 00000000	
000D88 _H	PFR08 [R/W] 0 - - 0 - 00	PFR09 [R/W] - - - - 000	PFR10 [R/W] - - - 0 - 00	Reserved	
000D8C _H	Reserved	Reserved	PFR14 [R/W] 00000000	PFR15 [R/W] 00000000	
000D90 _H	PFR16 [R/W] 00000000	PFR17 [R/W] 00000000	PFR18 [R/W] - 000 - 000	PFR19 [R/W] - 000 - 000	
000D94 _H	PFR20 [R/W] - 000 - 000	PFR21 [R/W] - 000 - 000	PFR22 [R/W] 00000000	PFR23 [R/W] 00000000	
000D98 _H	PFR24 [R/W] 00000000	PFR25 [R/W] - - - - - 00	PFR26 [R/W] 00000000	PFR27 [R/W] 00000000	
000D9C _H	PFR28 [R/W] 00000000	PFR29 [R/W] 00000000	PFR30 [R/W] 00000000	Reserved	
000DA0 _H	PFR32 [R/W] 0 - - - 0 - - -	PFR33 [R/W] 0 - - - 0 - - -	PFR34 [R/W] 00000000	PFR35 [R/W] 00000000	
000DA4 _H to 000DBC _H	Reserved				
000DC0 _H to 000DC8 _H	Reserved				
000DCC _H	Reserved	Reserved	EPFR10 [R/W] - - - - - 0	Reserved	R-bus Port Extra Function Register
000DCC _H	Reserved	Reserved	EPFR14 [R/W] 00000000	EPFR15 [R/W] 00000000	
000DD0 _H	EPFR16 [R/W] 0000 - - - -	EPFR17 [R/W] 00000000	EPFR18 [R/W] - 000 - 000	EPFR19 [R/W] - 0 - - - 0 - -	
000DD4 _H	EPFR20 [R/W] - 000 - 000	EPFR21 [R/W] - 0 - - - 0 - -	Reserved	Reserved	
000DD8 _H	EPFR24 [R/W] 0000 - - - -	Reserved	EPFR26 [R/W] 00000000	EPFR27 [R/W] 00000000	
000DDC _H	Reserved	Reserved	EPFR30 [R/W] 00000000	Reserved	
000DE0 _H	EPFR32 [R/W] 0 - - - 0 - - -	EPFR33 [R/W] 0 - - - 0 - - -	EPFR34 [R/W] 00000000	EPFR35 [R/W] 00000000	
000DE4 _H to 000DFC _H	Reserved				

Address	Register				Block
	+0	+1	+2	+3	
000E00 _H	PODR00 [R/W] 00000000	PODR01 [R/W] 00000000	Reserved	Reserved	R-bus Port Output Drive Select Register
000E04 _H	Reserved	PODR05 [R/W] 00000000	PODR06 [R/W] 00000000	PODR07 [R/W] 00000000	
000E08 _H	PODR08 [R/W] 0 - 0 - - 00	PODR09 [R/W] - - - - - 000	PODR10 [R/W] - - - - 0 - 00	Reserved	
000E0C _H	Reserved	Reserved	PODR14 [R/W] 00000000	PODR15 [R/W] 00000000	
000E10 _H	PODR16 [R/W] 00000000	PODR17 [R/W] 00000000	PODR18 [R/W] - 000 - 000	PODR19 [R/W] - 000 - 000	
000E14 _H	PODR20 [R/W] - 000 - 000	PODR21 [R/W] 0000 - 000	PODR22 [R/W] 00000000	PODR23 [R/W] 00000000	
000E18 _H	PODR24 [R/W] 00000000	PODR25 [R/W] - - - - - 00	PODR26 [R/W] 00000000	PODR27 [R/W] 00000000	
000E1C _H	PODR28 [R/W] 00000000	PODR29 [R/W] 00000000	PODR30 [R/W] 00000000	Reserved	
000E20 _H	PODR32 [R/W] 0 - - - 0 - - -	PODR33 [R/W] 0 - - - 0 - - -	PODR34 [R/W] 00000000	PODR35 [R/W] 00000000	
000E24 _H to 000E3C _H	Reserved				
000E40 _H	PILR00 [R/W] 00000000	PILR01 [R/W] 00000000	Reserved	Reserved	R-bus Port Input Level Select Register
000E44 _H	Reserved	PILR05 [R/W] 00000000	PILR06 [R/W] 00000000	PILR07 [R/W] 00000000	
000E48 _H	PILR08 [R/W] 0 - - 0 - - - 00	PILR09 [R/W] - - - - - 000	PILR10 [R/W] - - - - 0 - 00	Reserved	
000E4C _H	Reserved	Reserved	PILR14 [R/W] 00000000	PILR15 [R/W] 00000000	
000E50 _H	PILR16 [R/W] 00000000	PILR17 [R/W] 00000000	PILR18 [R/W] - 000 - 000	PILR19 [R/W] - 000 - 000	
000E54 _H	PILR20 [R/W] - 000 - 000	PILR21 [R/W] 0000 - 000	PILR22 [R/W] 00000000	PILR23 [R/W] 00000000	
000E58 _H	PILR24 [R/W] 00000000	PILR25 [R/W] - - - - - 00	PILR26 [R/W] 00000000	PILR27 [R/W] 00000000	
000E5C _H	PILR28 [R/W] 00000000	PILR29 [R/W] 00000000	PILR30 [R/W] 00000000	Reserved	
000E60 _H	PILR32 [R/W] 0 - - - 0 - - -	PILR33 [R/W] 0 - - - 0 - - -	PILR34 [R/W] 00000000	PILR35 [R/W] 00000000	
000E64 _H to 000E7C _H	Reserved				

Address	Register				Block
	+0	+1	+2	+3	
000E80 _H	EPILR00 [R/W] 00000000	EPILR01 [R/W] 00000000	Reserved	Reserved	R-bus Port Extra Input Level Select Register
000E84 _H	Reserved	EPILR05 [R/W] 00000000	EPILR06 [R/W] 00000000	EPILR07 [R/W] 00000000	
000E88 _H	EPILR08 [R/W] 0 - - 0 - - 00	EPILR09 [R/W] - - - - - 000	EPILR10 [R/W] - - - - 0 - 00	Reserved	
000E8C _H	Reserved	Reserved	EPILR14 [R/W] 00000000	EPILR15 [R/W] 00000000	
000E90 _H	EPILR16 [R/W] 00000000	EPILR17 [R/W] 00000000	EPILR18 [R/W] - 000 - 000	EPILR19 [R/W] - 000 - 000	
000E94 _H	EPILR20 [R/W] - 000 - 000	EPILR21 [R/W] 0000 - 000	EPILR22 [R/W] 00000000	EPILR23 [R/W] 00000000	
000E98 _H	EPILR24 [R/W] 00000000	EPILR25 [R/W] - - - - - 00	EPILR26 [R/W] 00000000	EPILR27 [R/W] 00000000	
000E9C _H	EPILR28 [R/W] 00000000	EPILR29 [R/W] 00000000	EPILR30 [R/W] 00000000	Reserved	
000EA0 _H	EPILR32 [R/W] 0 - - - 0 - - -	EPILR33 [R/W] 0 - - - 0 - - -	EPILR34 [R/W] 00000000	EPILR35 [R/W] 00000000	
000EA4 _H to 000EBC _H	Reserved				
000EC0 _H	PPER00 [R/W] 00000000	PPER01 [R/W] 00000000	Reserved	Reserved	R-bus Port Pull-Up/Down Enable Register
000EC4 _H	Reserved	PPER05 [R/W] 00000000	PPER06 [R/W] 00000000	PPER07 [R/W] 00000000	
000EC8 _H	PPER08 [R/W] 0 - - 0 - - 00	PPER09 [R/W] - - - - - 000	PPER10 [R/W] - - - - 0 - 00	Reserved	
000ECC _H	Reserved	Reserved	PPER14 [R/W] 00000000	PPER15 [R/W] 00000000	
000ED0 _H	PPER16 [R/W] 00000000	PPER17 [R/W] 00000000	PPER18 [R/W] - 000 - 000	PPER19 [R/W] - 000 - 000	
000ED4 _H	PPER20 [R/W] - 000 - 000	PPER21 [R/W] 0000 - 000	PPER22 [R/W] 00000000	PPER23 [R/W] 00000000	
000ED8 _H	PPER24 [R/W] 00000000	PPER25 [R/W] - - - - - 00	PPER26 [R/W] 00000000	PPER27 [R/W] 00000000	
000EDC _H	PPER28 [R/W] 00000000	PPER29 [R/W] 00000000	PPER30 [R/W] 00000000	Reserved	
000EE0 _H	PPER32 [R/W] 0 - - - 0 - - -	PPER33 [R/W] 0 - - - 0 - - -	PPER34 [R/W] 00000000	PPER35 [R/W] 00000000	
000EE4 _H to 000EFC _H	Reserved				

Address	Register				Block
	+0	+1	+2	+3	
000F00 _H	PPCR00 [R/W] 00000000	PPCR01 [R/W] 00000000	Reserved	Reserved	R-bus Port Pull-Up/Down Control Register
000F04 _H	Reserved	PPCR05 [R/W] 00000000	PPCR06 [R/W] 00000000	PPCR07 [R/W] 00000000	
000F08 _H	PPCR08 [R/W] 0 - - 0 - - 00	PPCR09 [R/W] - - - - - 000	PPCR10 [R/W] - - - - 0 - 00	Reserved	
000F0C _H	Reserved	Reserved	PPCR14 [R/W] 00000000	PPCR15 [R/W] 00000000	
000F10 _H	PPCR16 [R/W] 00000000	PPCR17 [R/W] 00000000	PPCR18 [R/W] - 000 - 000	PPCR19 [R/W] - 000 - 000	
000F14 _H	PPCR20 [R/W] - 000 - 000	PPCR21 [R/W] 0000 - 000	PPCR22 [R/W] 00000000	PPCR23 [R/W] 00000000	
000F18 _H	PPCR24 [R/W] 00000000	PPCR25 [R/W] - - - - - 00	PPCR26 [R/W] 00000000	PPCR27 [R/W] 00000000	
000F1C _H	PPCR28 [R/W] 00000000	PPCR29 [R/W] 00000000	PPCR30 [R/W] 00000000	Reserved	
000F20 _H	PPCR32 [R/W] 0 - - - 0 - - -	PPCR33 [R/W] 0 - - - 0 - - -	PPCR34 [R/W] 00000000	PPCR35 [R/W] 00000000	
000F24 _H to 000FFC _H	Reserved				
001000 _H	DMASA0 [R/W] XXXXXXXX XXXXXXXX XXXXXXXX XXXXXXXX				DMAC
001004 _H	DMADA0 [R/W] XXXXXXXX XXXXXXXX XXXXXXXX XXXXXXXX				
001008 _H	DMASA1 [R/W] XXXXXXXX XXXXXXXX XXXXXXXX XXXXXXXX				
00100C _H	DMADA1 [R/W] XXXXXXXX XXXXXXXX XXXXXXXX XXXXXXXX				
001010 _H	DMASA2 [R/W] XXXXXXXX XXXXXXXX XXXXXXXX XXXXXXXX				
001014 _H	DMADA2 [R/W] XXXXXXXX XXXXXXXX XXXXXXXX XXXXXXXX				
001018 _H	DMASA3 [R/W] XXXXXXXX XXXXXXXX XXXXXXXX XXXXXXXX				
00101C _H	DMADA3 [R/W] XXXXXXXX XXXXXXXX XXXXXXXX XXXXXXXX				
001020 _H	DMASA4 [R/W] XXXXXXXX XXXXXXXX XXXXXXXX XXXXXXXX				
001024 _H	DMADA4 [R/W] XXXXXXXX XXXXXXXX XXXXXXXX XXXXXXXX				
001028 _H to 001FFC _H	Reserved				

Address	Register				Block
	+0	+1	+2	+3	
002000 _H to 006FFC _H	CY91F465PA: Flash-cache size is 8 Kbytes : 004000 _H to 005FFC _H CY91F467PA: Flash-cache size is 8 Kbytes : 004000 _H to 005FFC _H				Flash-cache / I-RAM area
007000 _H	FMCS [R/W] 01101000	FMCR [R] --- 00000	FCHCR [R/W] ----- 00 10000011		Flash Memory/ F - Cache Control Register
007004 _H	FMWT [R/W] 11111111 11111111		FMWT2 [R] - 001 ----	FMPS [R/W] ----- 000	
007008 _H	FMAC [R] 00000000 00000000 00000000 00000000				
00700C _H	FCHA0 [R/W] ----- --- 00000 00000000 00000000				I-Cache Non-cacheable area setting Register
007010 _H	FCHA1 [R/W] ----- --- 00000 00000000 00000000				
007014 _H to 0070FC _H	Reserved				
007100 _H	FSCR0 [R/W, R] 11111111 11111111 11111111 11111111				Flash Security CRC Control register
007104 _H	FSCR1 [R, R/W] 0 --- 0001 00000000 00000000 00000000				
007108 _H to 007110 _H	Reserved				
007114 _H	DFCS [R/W] 0000 000X	DFWC [R/W] --- 0 0000	DFWS [R/W,R] 0000 0000	reserved	Data Flash Control register
007118 _H	DFSCR0 [R/W, R] 11111111 11111111 11111111 11111111				Data Flash Security CRC control
00711C _H	DFSCR1 [R, R/W] 0 --- 0000 00000000 00000000 00000000				
007120 _H to 007FFC _H	Reserved				
008000 _H to 00BFFC _H	CY91F465PA: Boot-ROM size is 4Kbytes: 00B000 _H to 00BFFC _H CY91F467PA: Boot-ROM size is 4Kbytes: 00B000 _H to 00BFFC _H (instruction access is 1 wait cycle, data access is 1 waitcycle)				Boot ROM area
00C000 _H	CTRLR0 [R/W] 00000000 00000001		STATR0 [R/W] 00000000 00000000		CAN 0 Control Register
00C004 _H	ERRCNT0 [R] 00000000 00000000		BTR0 [R/W] 00100011 00000001		
00C008 _H	INTR0 [R] 00000000 00000000		TESTR0 [R/W] 00000000 X0000000		
00C00C _H	BRPE0 [R/W] 00000000 00000000		Reserved		

Address	Register				Block
	+0	+1	+2	+3	
00C010 _H	IF1CREQ0 [R/W] 00000000 00000001		IF1CMSK0 [R/W] 00000000 00000000		CAN 0 IF 1 Register
00C014 _H	IF1MSK20 [R/W] 11111111 11111111		IF1MSK10 [R/W] 11111111 11111111		
00C018 _H	IF1ARB20 [R/W] 00000000 00000000		IF1ARB10 [R/W] 00000000 00000000		
00C01C _H	IF1MCTR0 [R/W] 00000000 00000000		Reserved		
00C020 _H	IF1DTA10 [R/W] 00000000 00000000		IF1DTA20 [R/W] 00000000 00000000		
00C024 _H	IF1DTB10 [R/W] 00000000 00000000		IF1DTB20 [R/W] 00000000 00000000		
00C028 _H to 00C02C _H	Reserved				
00C030 _H	IF1DTA20 [R/W] 00000000 00000000		IF1DTA10 [R/W] 00000000 00000000		
00C034 _H	IF1DTB20 [R/W] 00000000 00000000		IF1DTB10 [R/W] 00000000 00000000		
00C038 _H to 00C03C _H	Reserved				
00C040 _H	IF2CREQ0 [R/W] 00000000 00000001		IF2CMSK0 [R/W] 00000000 00000000		CAN 0 IF 2 Register
00C044 _H	IF2MSK20 [R/W] 11111111 11111111		IF2MSK10 [R/W] 11111111 11111111		
00C048 _H	IF2ARB20 [R/W] 00000000 00000000		IF2ARB10 [R/W] 00000000 00000000		
00C04C _H	IF2MCTR0 [R/W] 00000000 00000000		Reserved		
00C050 _H	IF2DTA10 [R/W] 00000000 00000000		IF2DTA20 [R/W] 00000000 00000000		
00C054 _H	IF2DTB10 [R/W] 00000000 00000000		IF2DTB20 [R/W] 00000000 00000000		
00C058 _H to 00C05C _H	Reserved				
00C060 _H	IF2DTA20 [R/W] 00000000 00000000		IF2DTA10 [R/W] 00000000 00000000		
00C064 _H	IF2DTB20 [R/W] 00000000 00000000		IF2DTB10 [R/W] 00000000 00000000		
00C068 _H to 00C07C _H	Reserved				

Address	Register				Block
	+0	+1	+2	+3	
00C080 _H	TREQR20 [R] 00000000 00000000		TREQR10 [R] 00000000 00000000		CAN 0 Status Flags
00C084 _H to 00C08C _H	Reserved				
00C090 _H	NEWDT20 [R] 00000000 00000000		NEWDT10 [R] 00000000 00000000		
00C094 _H to 00C09C _H	Reserved				
00C0A0 _H	INTPND20 [R] 00000000 00000000		INTPND10 [R] 00000000 00000000		
00C0A4 _H to 00C0AC _H	Reserved				
00C0B0 _H	MSGVAL20 [R] 00000000 00000000		MSGVAL10 [R] 00000000 00000000		
00C0B4 _H to 00C0FC _H	Reserved				
00C100 _H	CTRLR1 [R/W] 00000000 00000001		STATR1 [R/W] 00000000 00000000		CAN 1 Control Register
00C104 _H	ERRCNT1 [R] 00000000 00000000		BTR1 [R/W] 00100011 00000001		
00C108 _H	INTR1 [R] 00000000 00000000		TESTR1 [R/W] 00000000 X0000000		
00C10C _H	BRPE1 [R/W] 00000000 00000000		Reserved		

Address	Register				Block
	+0	+1	+2	+3	
00C110 _H	IF1CREQ1 [R/W] 00000000 00000001		IF1CMSK1 [R/W] 00000000 00000000		CAN 1 IF 1 Register
00C114 _H	IF1MSK21 [R/W] 11111111 11111111		IF1MSK11 [R/W] 11111111 11111111		
00C118 _H	IF1ARB21 [R/W] 00000000 00000000		IF1ARB11 [R/W] 00000000 00000000		
00C11C _H	IF1MCTR1 [R/W] 00000000 00000000		Reserved		
00C120 _H	IF1DTA11 [R/W] 00000000 00000000		IF1DTA21 [R/W] 00000000 00000000		
00C124 _H	IF1DTB11 [R/W] 00000000 00000000		IF1DTB21 [R/W] 00000000 00000000		
00C128 _H to 00C12C _H	Reserved				
00C130 _H	IF1DTA21 [R/W] 00000000 00000000		IF1DTA11 [R/W] 00000000 00000000		
00C134 _H	IF1DTB21 [R/W] 00000000 00000000		IF1DTB11 [R/W] 00000000 00000000		
00C138 _H to 00C13C _H	Reserved				
00C140 _H	IF2CREQ1 [R/W] 00000000 00000001		IF2CMSK1 [R/W] 00000000 00000000		CAN 1 IF 2 Register
00C144 _H	IF2MSK21 [R/W] 11111111 11111111		IF2MSK11 [R/W] 11111111 11111111		
00C148 _H	IF2ARB21 [R/W] 00000000 00000000		IF2ARB11 [R/W] 00000000 00000000		
00C14C _H	IF2MCTR1 [R/W] 00000000 00000000		Reserved		
00C150 _H	IF2DTA11 [R/W] 00000000 00000000		IF2DTA21 [R/W] 00000000 00000000		
00C154 _H	IF2DTB11 [R/W] 00000000 00000000		IF2DTB21 [R/W] 00000000 00000000		
00C158 _H to 00C15C _H	Reserved				
00C160 _H	IF2DTA21 [R/W] 00000000 00000000		IF2DTA11 [R/W] 00000000 00000000		
00C164 _H	IF2DTB21 [R/W] 00000000 00000000		IF2DTB11 [R/W] 00000000 00000000		
00C168 _H to 00C17C _H	Reserved				

Address	Register				Block
	+0	+1	+2	+3	
00C180 _H	TREQR21 [R] 00000000 00000000		TREQR11 [R] 00000000 00000000		CAN 1 Status Flags
00C184 _H to 00C18C _H	Reserved				
00C190 _H	NEWDT21 [R] 00000000 00000000		NEWDT11 [R] 00000000 00000000		
00C194 _H to 00C19C _H	Reserved				
00C1A0 _H	INTPND21 [R] 00000000 00000000		INTPND11 [R] 00000000 00000000		
00C1A4 _H to 00C1AC _H	Reserved				
00C1B0 _H	MSGVAL21 [R] 00000000 00000000		MSGVAL11 [R] 00000000 00000000		
00C1B4 _H to 00C1FC _H	Reserved				
00C200 _H	CTRLR2 [R/W] 00000000 00000001		STATR2 [R/W] 00000000 00000000		CAN 2 Control Register
00C204 _H	ERRCNT2 [R] 00000000 00000000		BTR2 [R/W] 00100011 00000001		
00C208 _H	INTR2 [R] 00000000 00000000		TESTR2 [R/W] 00000000 X0000000		
00C20C _H	BRPE2 [R/W] 00000000 00000000		Reserved		

Address	Register				Block
	+0	+1	+2	+3	
00C210 _H	IF1CREQ2 [R/W] 00000000 00000001		IF1CMSK2 [R/W] 00000000 00000000		CAN 2 IF 1 Register
00C214 _H	IF1MSK22 [R/W] 11111111 11111111		IF1MSK12 [R/W] 11111111 11111111		
00C218 _H	IF1ARB22 [R/W] 00000000 00000000		IF1ARB12 [R/W] 00000000 00000000		
00C21C _H	IF1MCTR2 [R/W] 00000000 00000000		Reserved		
00C220 _H	IF1DTA12 [R/W] 00000000 00000000		IF1DTA22 [R/W] 00000000 00000000		
00C224 _H	IF1DTB12 [R/W] 00000000 00000000		IF1DTB22 [R/W] 00000000 00000000		
00C228 _H to 00C22C _H	Reserved				
00C230 _H	IF1DTA22 [R/W] 00000000 00000000		IF1DTA12 [R/W] 00000000 00000000		
00C234 _H	IF1DTB22 [R/W] 00000000 00000000		IF1DTB12 [R/W] 00000000 00000000		
00C238 _H to 00C23C _H	Reserved				
00C240 _H	IF2CREQ2 [R/W] 00000000 00000001		IF2CMSK2 [R/W] 00000000 00000000		CAN 2 IF 2 Register
00C244 _H	IF2MSK22 [R/W] 11111111 11111111		IF2MSK12 [R/W] 11111111 11111111		
00C248 _H	IF2ARB22 [R/W] 00000000 00000000		IF2ARB12 [R/W] 00000000 00000000		
00C24C _H	IF2MCTR2 [R/W] 00000000 00000000		Reserved		
00C250 _H	IF2DTA12 [R/W] 00000000 00000000		IF2DTA22 [R/W] 00000000 00000000		
00C254 _H	IF2DTB12 [R/W] 00000000 00000000		IF2DTB22 [R/W] 00000000 00000000		
00C258 _H to 00C25C _H	Reserved				
00C260 _H	IF2DTA22 [R/W] 00000000 00000000		IF2DTA12 [R/W] 00000000 00000000		
00C264 _H	IF2DTB22 [R/W] 00000000 00000000		IF2DTB12 [R/W] 00000000 00000000		
00C268 _H to 00C27C _H	Reserved				

Address	Register				Block
	+0	+1	+2	+3	
00C280 _H	TREQR22 [R] 00000000 00000000		TREQR12 [R] 00000000 00000000		CAN 2 Status Flags
00C284 _H to 00C28C _H	Reserved				
00C290 _H	NEWDT22 [R] 00000000 00000000		NEWDT12 [R] 00000000 00000000		
00C294 _H to 00C29C _H	Reserved				
00C2A0 _H	INTPND22 [R] 00000000 00000000		INTPND12 [R] 00000000 00000000		
00C2A4 _H to 00C2AC _H	Reserved				
00C2B0 _H	MSGVAL22 [R] 00000000 00000000		MSGVAL12 [R] 00000000 00000000		
00C2B4 _H to 00C2FC _H	Reserved				
00C300 _H	CTRLR3 [R/W] 00000000 00000001		STATR3 [R/W] 00000000 00000000		CAN 3 Control Register (CY91F467PA)
00C304 _H	ERRCNT3 [R] 00000000 00000000		BTR3 [R/W] 00100011 00000001		
00C308 _H	INTR3 [R] 00000000 00000000		TESTR3 [R/W] 00000000 X0000000		
00C30C _H	BRPE3 [R/W] 00000000 00000000		Reserved		

Address	Register				Block	
	+0	+1	+2	+3		
00C310 _H	IF1CREQ3 [R/W] 00000000 00000001		IF1CMSK3 [R/W] 00000000 00000000		CAN 3 IF 1 Register (CY91F467PA)	
00C314 _H	IF1MSK23 [R/W] 11111111 11111111		IF1MSK13 [R/W] 11111111 11111111			
00C318 _H	IF1ARB23 [R/W] 00000000 00000000		IF1ARB13 [R/W] 00000000 00000000			
00C31C _H	IF1MCTR3 [R/W] 00000000 00000000		Reserved			
00C320 _H	IF1DTA13 [R/W] 00000000 00000000		IF1DTA23 [R/W] 00000000 00000000			
00C324 _H	IF1DTB13 [R/W] 00000000 00000000		IF1DTB23 [R/W] 00000000 00000000			
00C328 _H to 00C32C _H	Reserved					
00C330 _H	IF1DTA23 [R/W] 00000000 00000000		IF1DTA13 [R/W] 00000000 00000000			
00C334 _H	IF1DTB23 [R/W] 00000000 00000000		IF1DTB13 [R/W] 00000000 00000000			
00C338 _H to 00C33C _H	Reserved					
00C340 _H	IF2CREQ3 [R/W] 00000000 00000001		IF2CMSK3 [R/W] 00000000 00000000			CAN 3 IF 2 Register (CY91F467PA)
00C344 _H	IF2MSK23 [R/W] 11111111 11111111		IF2MSK13 [R/W] 11111111 11111111			
00C348 _H	IF2ARB23 [R/W] 00000000 00000000		IF2ARB13 [R/W] 00000000 00000000			
00C34C _H	IF2MCTR3 [R/W] 00000000 00000000		Reserved			
00C350 _H	IF2DTA13 [R/W] 00000000 00000000		IF2DTA23 [R/W] 00000000 00000000			
00C354 _H	IF2DTB13 [R/W] 00000000 00000000		IF2DTB23 [R/W] 00000000 00000000			
00C358 _H to 00C35C _H	Reserved					
00C360 _H	IF2DTA23 [R/W] 00000000 00000000		IF2DTA13 [R/W] 00000000 00000000			
00C364 _H	IF2DTB23 [R/W] 00000000 00000000		IF2DTB13 [R/W] 00000000 00000000			
00C368 _H to 00C37C _H	Reserved					

Address	Register				Block	
	+0	+1	+2	+3		
00C380 _H	TREQR23 [R] 00000000 00000000		TREQR13 [R] 00000000 00000000		CAN 3 Status Flags (CY91F467PA)	
00C384 _H to 00C38C _H	Reserved					
00C390 _H	NEWDT23 [R] 00000000 00000000		NEWDT13 [R] 00000000 00000000			
00C394 _H to 00C39C _H	Reserved					
00C3A0 _H	INTPND23 [R] 00000000 00000000		INTPND13 [R] 00000000 00000000			
00C3A4 _H to 00C3AC _H	Reserved					
00C3B0 _H	MSGVAL23 [R] 00000000 00000000		MSGVAL13 [R] 00000000 00000000			
00C3B4 _H to 00EFFC _H	Reserved					
00F000 _H	BCTRL [R/W] ----- 11111100 00000000					EDSU / MPU
00F004 _H	BSTAT [R/W] ----- 000 00000000 10 -- 0000					
00F008 _H	BIAC [R] ----- 00000000 00000000					
00F00C _H	BOAC [R] ----- 00000000 00000000					
00F010 _H	BIRQ [R/W] ----- 00000000 00000000					
00F014 _H to 00F01C _H	Reserved					
00F020 _H	BCR0 [R/W] ----- 00000000 00000000 00000000					
00F024 _H	BCR1 [R/W] ----- 00000000 00000000 00000000					
00F028 _H	BCR2 [R/W] ----- 00000000 00000000 00000000					
00F02C _H	BCR3 [R/W] ----- 00000000 00000000 00000000					
00F030 _H to 00F07C _H	Reserved					

Address	Register				Block
	+0	+1	+2	+3	
00F080 _H	BAD0 [R/W] XXXXXXXX XXXXXXXX XXXXXXXX XXXXXXXX				EDSU / MPU
00F084 _H	BAD1 [R/W] XXXXXXXX XXXXXXXX XXXXXXXX XXXXXXXX				
00F088 _H	BAD2 [R/W] XXXXXXXX XXXXXXXX XXXXXXXX XXXXXXXX				
00F08C _H	BAD3 [R/W] XXXXXXXX XXXXXXXX XXXXXXXX XXXXXXXX				
00F090 _H	BAD4 [R/W] XXXXXXXX XXXXXXXX XXXXXXXX XXXXXXXX				
00F094 _H	BAD5 [R/W] XXXXXXXX XXXXXXXX XXXXXXXX XXXXXXXX				
00F098 _H	BAD6 [R/W] XXXXXXXX XXXXXXXX XXXXXXXX XXXXXXXX				
00F09C _H	BAD7 [R/W] XXXXXXXX XXXXXXXX XXXXXXXX XXXXXXXX				
00F0A0 _H	BAD8 [R/W] XXXXXXXX XXXXXXXX XXXXXXXX XXXXXXXX				
00F0A4 _H	BAD9 [R/W] XXXXXXXX XXXXXXXX XXXXXXXX XXXXXXXX				
00F0A8 _H	BAD10 [R/W] XXXXXXXX XXXXXXXX XXXXXXXX XXXXXXXX				
00F0AC _H	BAD11 [R/W] XXXXXXXX XXXXXXXX XXXXXXXX XXXXXXXX				
00F0B0 _H	BAD12 [R/W] XXXXXXXX XXXXXXXX XXXXXXXX XXXXXXXX				
00F0B4 _H	BAD13 [R/W] XXXXXXXX XXXXXXXX XXXXXXXX XXXXXXXX				
00F0B8 _H	BAD14 [R/W] XXXXXXXX XXXXXXXX XXXXXXXX XXXXXXXX				
00F0BC _H	BAD15 [R/W] XXXXXXXX XXXXXXXX XXXXXXXX XXXXXXXX				
00F0C0 _H to 023FFC _H	Reserved				
024000 _H to 02FFFC _H	CY91F467PA: D-RAM size is 48Kbytes: 024000 _H to 02FFFC _H CY91F465PA: D-RAM size is 24Kbytes: 02A000 _H to 02FFFC _H (data access is 0 wait cycles)				D-RAM area
030000 _H to 037FFC _H	CY91F465PA: ID-RAM size is 16Kbytes: 030000 _H to 033FFC _H CY91F467PA: ID-RAM size is 32Kbytes: 030000 _H to 037FFC _H (instruction access is 0 waitcycles, data access is 1 wait cycle)				ID-RAM area

1. Writable only once and only as half-word. PPMUX is reset by INIT and RST.
2. PPMUX2 is available on CY91F467PA only. Writable only once and only as half-word, reset by INIT and RST.
3. Depends on the number of available CAN channels:
CY91F465PA has 3 CAN channels - bits[2:0] exist
CY91F467PA has 4 CAN channels - bits[3:0] exist

4. ADC1 is only available on CY91F467PA.
5. ACRO[11:10] depends on Modevector fetch information on buswidth.
6. TCR [3:0] INIT value = 0000, keeps value after RST.
7. Range Comparator for ADC0, ADC1 are only available on CY91F467PA.
8. ADC0, ADC1 channel data registers are only available on CY91F467PA.
9. On CY91F467PA, always write 1 to bit IOS[1].
10. PFR initial values for ports 00--10 depend on the selected mode at the modepins MD_0--MD_2:
 - internal vector fetch mode (MD=000): PFR00--PFR10 initialized to all '0'
 - external vector fetch mode (MD=001): PFR00--PFR10 initialized to all '1'

18.2 Flash Memory, Data Flash and External Bus Area

32bit read/write *1	dat[31:0]				dat[31:0]				Block
	dat[31:16]		dat[15:0]		dat[31:16]		dat[15:0]		
	Register								
Address	+ 0	+ 1	+ 2	+ 3	+ 4	+ 5	+ 6	+ 7	
040000 _H to 05FFFF _H	SA8 (64KB, CY91F467PA) External bus (CY91F465PA)				SA9 (64KB, CY91F467PA) External bus (CY91F465PA)				ROMS0
060000 _H to 07FFFF _H	SA10 (64KB, CY91F467PA) External bus (CY91F465PA)				SA11 (64KB, CY91F467PA) External bus (CY91F465PA)				ROMS1
080000 _H to 09FFFF _H	SA12(64kB)				SA13(64kB)				ROMS2
0A0000 _H to 0BFFFF _H	SA14(64kB)				SA15(64kB)				ROMS3
0C0000 _H to 0DFFFF _H	SA16(64kB)				SA17(64kB)				ROMS4
0E0000 _H to 0FFFF4 _H	SA18(64kB)				SA19(64kB)				ROMS5
0FFFF _H	FMV [R] *2 06 00 00 00 _H				FRV [R] 00 00 BF F8 _H				
100000 _H to 11FFF8 _H	SA20 (64KB, CY91F467PA) External bus (CY91F465PA)				SA21 (64KB, CY91F467PA) External bus (CY91F465PA)				ROMS6
120000 _H to 13FFF8 _H	SA22 (64KB, CY91F467PA) External bus (CY91F465PA)				SA23 (64KB, CY91F467PA) External bus (CY91F465PA)				
140000 _H to 143FFC _H	SA0 (8KB, CY91F467PA) Reserved (CY91F465PA)				SA1 (8KB, CY91F467PA) Reserved (CY91F465PA)				ROMS7
144000 _H to 17FFC _H	SA2 (8KB, CY91F467PA) Reserved (CY91F465PA)				SA3 (8KB, CY91F467PA) Reserved (CY91F465PA)				
148000 _H to 14BFFC _H	SA4(8kB)				SA5(8kB)				
14C000 _H to 14FFFF _H	SA6(8kB)				SA7(8kB)				
150000 _H to 17FFFF _H	Reserved								ROMS7 (continued)

32bit read/write *1	dat[31:0]				dat[31:0]				Block
	dat[31:16]		dat[15:0]		dat[31:16]		dat[15:0]		
Address	Register								
	+ 0	+ 1	+ 2	+ 3	+ 4	+ 5	+ 6	+ 7	
180000 _H to 1BFFFC _H	External Bus Area								ROMS8
1C0000 _H to 1FFFFC _H									ROMS9
200000 _H to 27FFFC _H									ROMS10
280000 _H to 2FFFFC _H									ROMS11
300000 _H to 37FFFC _H									ROMS12
380000 _H to 3FFFFC _H									ROMS13
400000 _H to 47FFFC _H									ROMS14
480000 _H to 4FFFFC _H									ROMS15
500000 _H - FFFBEFFC _H									External Bus Area
FFFBF000 _H - FFFCFFFC _H	Data Flash area (if enabled) or External Bus area, Data Flash on CY91F467PA is 64 KB + 256 Byte								Data Flash area *3
FFFD0000 _H - FFFFFFFC _H	External Bus Area								External bus area

- 32-bit write to flash memory only available on CY91F467PA.
- Write operations to address 0FFFF8H and 0FFFFCH are not possible.
When reading these addresses, the values shown above will be read.
- Data Flash is only available on CY91F467PA.

18.3 Data Flash memory sector organisation

The Data Flash sectors can be accessed only after the data flash has been enabled by setting DFCS:FLASHEN. If the data flash is enabled, the user must ensure that no chip select area overlaps the data flash address space.

CY91F467PA					
32bit access	dat[31:0]				
16bit access	dat[31:16]		dat[15:0]		
8bit access	dat[7:0]	dat[7:0]	dat[7:0]	dat[7:0]	
Address	+ 0	+ 1	+ 2	+ 3	Comments
... to FFFB EFFC _H	External bus area				
FFFB F000 _H to FFFB FEFC _H	Dummy area for flash auto algorithm addressing (write sequences)				Data Flash
FFFB FF00 _H to FFFB FFFC _H	SAS (256 Byte) Security Sector				
FFFC 0000 _H to FFFC 3FFC _H	SA0 (16 KB)				
FFFC 4000 _H to FFFC 7FFC _H	SA1 (16 KB)				
FFFC 8000 _H to FFFC BFFC _H	SA2 (16 KB)				
FFFC C000 _H to FFFC FFFC _H	SA3 (16 KB)				
FFFD 0000 _H to FFFF FFFC _H	External bus area				

19. Interrupt Vector Table

Interrupt	Interrupt number		Interrupt level *1		Interrupt vector *2		DMA Resource number
	Decimal	Hexa-decimal	Setting Register	Register address	Offset	Default vector address	
Reset	0	00	—	—	3FC _H	000FFFFC	—
Mode vector	1	01	—	—	3F8 _H	000FFFF8	—
System reserved	2	02	—	—	3F4 _H	000FFFF4	—
System reserved	3	03	—	—	3F0 _H	000FFFF0	—
System reserved	4	04	—	—	3EC _H	000FFFE4	—
CPU supervisor mode (INT #5 instruction) *5	5	05	—	—	3E8 _H	000FFFE8	—
Memory Protection exception *5	6	06	—	—	3E4 _H	000FFFE4	—
System reserved	7	07	—	—	3E0 _H	000FFFE0	—
System reserved	8	08	—	—	3DC _H	000FFFD4	—
System reserved	9	09	—	—	3D8 _H	000FFFD8	—
System reserved	10	0A	—	—	3D4 _H	000FFFD4	—
System reserved	11	0B	—	—	3D0 _H	000FFFD0	—
System reserved	12	0C	—	—	3CC _H	000FFFC4	—
System reserved	13	0D	—	—	3C8 _H	000FFFC8	—
Undefined instruction exception	14	0E	—	—	3C4 _H	000FFFC4	—
NMI request	15	0F	F _H fixed		3C0 _H	000FFFC0	—
External Interrupt 0	16	10	ICR00	440 _H	3BC _H	000FFFB4	0, 16
External Interrupt 1	17	11			3B8 _H	000FFFB8	1, 17
External Interrupt 2	18	12	ICR01	441 _H	3B4 _H	000FFFB4	2, 18
External Interrupt 3	19	13			3B0 _H	000FFFB0	3, 19
External Interrupt 4	20	14	ICR02	442 _H	3AC _H	000FFFA4	20
External Interrupt 5	21	15			3A8 _H	000FFFA8	21
External Interrupt 6	22	16	ICR03	443 _H	3A4 _H	000FFFA4	22
External Interrupt 7	23	17			3A0 _H	000FFFA0	23
External Interrupt 8	24	18	ICR04	444 _H	39C _H	000FFF94	—
External Interrupt 9	25	19			398 _H	000FFF98	—
External Interrupt 10	26	1A	ICR05	445 _H	394 _H	000FFF94	—
External Interrupt 11	27	1B			390 _H	000FFF90	—
External Interrupt 12	28	1C	ICR06	446 _H	38C _H	000FFF84	—
External Interrupt 13	29	1D			388 _H	000FFF88	—
External Interrupt 14	30	1E	ICR07	447 _H	384 _H	000FFF84	—
External Interrupt 15	31	1F			380 _H	000FFF80	—
Reload Timer 0 Reload Timer 8	32	20	ICR08	448 _H	37C _H	000FFF74	4, 32 128
Reload Timer 1 Reload Timer 9	33	21			378 _H	000FFF78	5, 33 129

Interrupt	Interrupt number		Interrupt level *1		Interrupt vector *2		DMA Resource number
	Decimal	Hexa-decimal	Setting Register	Register address	Offset	Default vector address	
Reload Timer 2 Reload Timer 10	34	22	ICR09	449 _H	374 _H	000FFF74	34 130
Reload Timer 3 Reload Timer 11	35	23			370 _H	000FFF70	35 131
Reload Timer 4 Reload Timer 12	36	24	ICR10	44A _H	36C _H	000FFF6C	36 132
Reload Timer 5 Reload Timer 13	37	25			368 _H	000FFF68	37 133
Reload Timer 6 Reload Timer 14	38	26	ICR11	44B _H	364 _H	000FFF64	38 134
Reload Timer 7 Reload Timer 15	39	27			360 _H	000FFF60	39 135
Free Run Timer 0	40	28	ICR12	44C _H	35C _H	000FFF5C	40
Free Run Timer 1	41	29			358 _H	000FFF58	41
Free Run Timer 2	42	2A	ICR13	44D _H	354 _H	000FFF54	42
Free Run Timer 3	43	2B			350 _H	000FFF50	43
Free Run Timer 4	44	2C	ICR14	44E _H	34C _H	000FFF4C	44
Free Run Timer 5	45	2D			348 _H	000FFF48	45
Free Run Timer 6	46	2E	ICR15	44F _H	344 _H	000FFF44	46
Free Run Timer 7	47	2F			340 _H	000FFF40	47
CAN 0	48	30	ICR16	450 _H	33C _H	000FFF3C	—
CAN 1	49	31			338 _H	000FFF38	—
CAN 2	50	32	ICR17	451 _H	334 _H	000FFF34	—
CAN 3 *6	51	33			330 _H	000FFF30	—
Reserved	52	34	ICR18	452 _H	32C _H	000FFF2C	—
Reserved	53	35			328 _H	000FFF28	—
LIN-USART 0 RX	54	36	ICR19	453 _H	324 _H	000FFF24	6, 48
LIN-USART 0 TX	55	37			320 _H	000FFF20	7, 49
LIN-USART 1 RX	56	38	ICR20	454 _H	31C _H	000FFF1C	8, 50
LIN-USART 1 TX	57	39			318 _H	000FFF18	9, 51
LIN-USART 2 RX	58	3A	ICR21	455 _H	314 _H	000FFF14	52
LIN-USART 2 TX	59	3B			310 _H	000FFF10	53
LIN-USART 3 RX	60	3C	ICR22	456 _H	30C _H	000FFF0C	54
LIN-USART 3 TX	61	3D			308 _H	000FFF08	55
System reserved	62	3E	ICR23 *3	457 _H	304 _H	000FFF04	—
Delayed Interrupt	63	3F			300 _H	000FFF00	—
System reserved *4	64	40	(ICR24)	(458 _H)	2FC _H	000FFEFC	—
System reserved *4	65	41			2F8 _H	000FFE8	—
LIN-USART (FIFO) 4 RX	66	42	ICR25	459 _H	2F4 _H	000FEF4	10, 56
LIN-USART (FIFO) 4 TX	67	43			2F0 _H	000FEF0	11, 57

Interrupt	Interrupt number		Interrupt level *1		Interrupt vector *2		DMA Resource number
	Decimal	Hexa-decimal	Setting Register	Register address	Offset	Default vector address	
LIN-USART (FIFO) 5 RX	68	44	ICR26	45A _H	2EC _H	000FFEEC	12, 58
LIN-USART (FIFO) 5 TX	69	45			2E8 _H	000FFEE8	13, 59
LIN-USART (FIFO) 6 RX	70	46	ICR27	45B _H	2E4 _H	000FFEE4	60
LIN-USART (FIFO) 6 TX	71	47			2E0 _H	000FFEE0	61
LIN-USART (FIFO) 7 RX	72	48	ICR28	45C _H	2DC _H	000FFEDC	62
LIN-USART (FIFO) 7 TX	73	49			2D8 _H	000FFED8	63
I ² C 0 / I ² C 2	74	4A	ICR29	45D _H	2D4 _H	000FFED4	—
I ² C 1 / I ² C 3	75	4B			2D0 _H	000FFED0	—
LIN-USART 8 RX	76	4C	ICR30	45E _H	2CC _H	000FFEC C	64
LIN-USART 8 TX	77	4D			2C8 _H	000FFEC8	65
LIN-USART 9 RX	78	4E	ICR31	45F _H	2C4 _H	000FFEC4	66
LIN-USART 9 TX	79	4F			2C0 _H	000FFEC0	67
LIN-USART 10 RX	80	50	ICR32	460 _H	2BC _H	000FFEB C	68
LIN-USART 10 TX	81	51			2B8 _H	000FFEB8	69
LIN-USART 11 RX	82	52	ICR33	461 _H	2B4 _H	000FFEB4	70
LIN-USART 11 TX	83	53			2B0 _H	000FFEB0	71
Reserved	84	54	ICR34	462 _H	2AC _H	000FFEAC	72
Reserved	85	55			2A8 _H	000FFE A8	73
Reserved	86	56	ICR35	463 _H	2A4 _H	000FFE A4	74
Reserved	87	57			2A0 _H	000FFE A0	75
Reserved	88	58	ICR36	464 _H	29C _H	000FFE9 C	76
Reserved	89	59			298 _H	000FFE98	77
Reserved	90	5A	ICR37	465 _H	294 _H	000FFE94	78
Reserved	91	5B			290 _H	000FFE90	79
Input Capture 0	92	5C	ICR38	466 _H	28C _H	000FFE8 C	80
Input Capture 1	93	5D			288 _H	000FFE88	81
Input Capture 2	94	5E	ICR39	467 _H	284 _H	000FFE84	82
Input Capture 3	95	5F			280 _H	000FFE80	83
Input Capture 4	96	60	ICR40	468 _H	27C _H	000FFE7 C	84
Input Capture 5	97	61			278 _H	000FFE78	85
Input Capture 6	98	62	ICR41	469 _H	274 _H	000FFE74	86
Input Capture 7	99	63			270 _H	000FFE70	87
Output Compare 0	100	64	ICR42	46A _H	26C _H	000FFE6 C	88
Output Compare 1	101	65			268 _H	000FFE68	89
Output Compare 2	102	66	ICR43	46B _H	264 _H	000FFE64	90
Output Compare 3	103	67			260 _H	000FFE60	91
Output Compare 4	104	68	ICR44	46C _H	25C _H	000FFE5 C	92
Output Compare 5	105	69			258 _H	000FFE58	93

Interrupt	Interrupt number		Interrupt level *1		Interrupt vector *2		DMA Resource number
	Decimal	Hexa-decimal	Setting Register	Register address	Offset	Default vector address	
Output Compare 6	106	6A	ICR45	46D _H	254 _H	000FFE54	94
Output Compare 7	107	6B			250 _H	000FFE50	95
Sound Generator	108	6C	ICR46	46E _H	24C _H	000FFE4C	—
Phase Frequency Modulator	109	6D			248 _H	000FFE48	—
System reserved	110	6E	ICR47 *3	46F _H	244 _H	000FFE44	—
System reserved	111	6F			240 _H	000FFE40	—
PPG0 PPG16	112	70	ICR48	470 _H	23C _H	000FFE3C	15, 96 144
PPG1 PPG17	113	71			238 _H	000FFE38	97 145
PPG2 PPG18	114	72	ICR49	471 _H	234 _H	000FFE34	98 146
PPG3 PPG19	115	73			230 _H	000FFE30	99 147
PPG4 PPG20	116	74	ICR50	472 _H	22C _H	000FFE2C	100 148
PPG5 PPG21	117	75			228 _H	000FFE28	101 149
PPG6 PPG22	118	76	ICR51	473 _H	224 _H	000FFE24	102 150
PPG7 PPG23	119	77			220 _H	000FFE20	103 151
PPG8 PPG24	120	78	ICR52	474 _H	21C _H	000FFE1C	104 152
PPG9 PPG25	121	79			218 _H	000FFE18	105 153
PPG10 PPG26	122	7A	ICR53	475 _H	214 _H	000FFE14	106 154
PPG11 PPG27	123	7B			210 _H	000FFE10	107 155
PPG12 PPG28	124	7C	ICR54	476 _H	20C _H	000FFE0C	108 156
PPG13 PPG29	125	7D			208 _H	000FFE08	109 157
PPG14 PPG30	126	7E	ICR55	477 _H	204 _H	000FFE04	110 158
PPG15 PPG31	127	7F			200 _H	000FFE00	111 159
Up/Down Counter 0	128	80	ICR56	478 _H	1FC _H	000FFDFC	—
Up/Down Counter 1	129	81			1F8 _H	000FFDF8	—
Up/Down Counter 2	130	82	ICR57	479 _H	1F4 _H	000FFDF4	—
Up/Down Counter 3	131	83			1F0 _H	000FFDF0	—

Interrupt	Interrupt number		Interrupt level *1		Interrupt vector *2		DMA Resource number
	Decimal	Hexa-decimal	Setting Register	Register address	Offset	Default vector address	
Real Time Clock	132	84	ICR58	47A _H	1EC _H	000FFDEC	—
Calibration Unit	133	85			1E8 _H	000FFDE8	—
A/D Converter 0 A/D Converter 0 End of Scan *6	134	86	ICR59	47B _H	1E4 _H	000FFDE4	14, 112 120 *6
A/D Converter 1 *6 A/D Converter 1 End of Scan *6	135	87			1E0 _H	000FFDE0	113 *6 121 *6
Reserved	136	88	ICR60	47C _H	1DC _H	000FFDDC	—
Reserved	137	89			1D8 _H	000FFDD8	—
Low Voltage Detection	138	8A	ICR61	47D _H	1D4 _H	000FFDD4	—
Reserved	139	8B			1D0 _H	000FFDD0	—
Timebase Overflow	140	8C	ICR62	47E _H	1CC _H	000FFDCC	—
PLL Clock Gear Data Flash Write Complete *6	141	8D			1C8 _H	000FFDC8	— 195 *6
DMA Controller	142	8E	ICR63	47F _H	1C4 _H	000FFDC4	—
Main/Sub OSC stability wait	143	8F			1C0 _H	000FFDC0	—
Security vector	144	90	—	—	1BC _H	000FFDBC	—
Used by the INT instruction	145 to 255	91 to FF	—	—	1B8 _H to 000 _H	000FFDB8 to 000FFC00	—

Notes:

*1 The Interrupt Control Registers (ICRs) are located in the interrupt controller and set the interrupt level for each interrupt request. An ICR is provided for each interrupt request.

*2 The vector address for each EIT (exception, interrupt or trap) is calculated by adding the listed offset to the table base register value (TBR). The TBR specifies the top of the EIT vector table. The addresses listed in the table are for the default TBR value (000FFC00_H). The TBR is initialized to this value by a reset. The TBR is set to 000FFC00_H after the internal boot ROM is executed.

*3 ICR23 and ICR47 can be exchanged by setting the REALOS compatibility bit (addr 0C03_H : IOS[0])

*4 Used by REALOS

*5 Memory Protection Unit (MPU) support

*6 CAN 3, Data Flash, ADC1 and ADC0 (End of Scan) interrupts are available on CY91F467PA only.

20. Recommended Settings

20.1 PLL and Clockgear settings

Please note that for CY91F465PA the core base clock frequencies are valid in the 1.8V operation mode of the Main regulator and Flash.

Recommended PLL divider and clockgear settings

PLL Input (CLK) [MHz]	Frequency Parameter		Clockgear Parameter		PLL Output (X) [MHz]	Core Base Clock [MHz]	Remarks
	DIVM	DIVN	DIVG	MULG			
4	2	25	16	24	200	100	
4	2	24	16	24	192	96	
4	2	23	16	24	184	92	
4	2	22	16	24	176	88	
4	2	21	16	20	168	84	
4	2	20	16	20	160	80	
4	2	19	16	20	152	76	
4	2	18	16	20	144	72	
4	2	17	16	16	136	68	
4	2	16	16	16	128	64	
4	2	15	16	16	120	60	
4	2	14	16	16	112	56	
4	2	13	16	12	104	52	
4	2	12	16	12	96	48	
4	2	11	16	12	88	44	
4	4	10	16	24	160	40	
4	4	9	16	24	144	36	
4	4	8	16	24	128	32	
4	4	7	16	24	112	28	
4	6	6	16	24	144	24	
4	8	5	16	28	160	20	
4	10	4	16	32	160	16	
4	12	3	16	32	144	12	

20.2 Clock Modulator settings

The following table shows all possible settings for the Clock Modulator in a base clock frequency range from 32MHz up to 88MHz. The Flash access time settings need to be adjusted according to Fmax while the PLL and clockgear settings should be set according to base clock frequency.

Clock Modulator settings, frequency range and supported supply voltage

Modulation Degree (k)	Random No (N)	CMPR [hex]	Baseclk [MHz]	Fmin [MHz]	Fmax [MHz]
1	3	026F	88	79.5	98.5
1	3	026F	84	76.1	93.8
1	3	026F	80	72.6	89.1
1	5	02AE	80	68.7	95.8
2	3	046E	80	68.7	95.8
1	3	026F	76	69.1	84.5
1	5	02AE	76	65.3	90.8
1	7	02ED	76	62	98.1
2	3	046E	76	65.3	90.8
3	3	066D	76	62	98.1
1	3	026F	72	65.5	79.9
1	5	02AE	72	62	85.8
1	7	02ED	72	58.8	92.7
2	3	046E	72	62	85.8
3	3	066D	72	58.8	92.7
1	3	026F	68	62	75.3
1	5	02AE	68	58.7	80.9
1	7	02ED	68	55.7	87.3
1	9	032C	68	53	95
2	3	046E	68	58.7	80.9
2	5	04AC	68	53	95
3	3	066D	68	55.7	87.3
4	3	086C	68	53	95
1	3	026F	64	58.5	70.7
1	5	02AE	64	55.3	75.9
1	7	02ED	64	52.5	82
1	9	032C	64	49.9	89.1
1	11	036B	64	47.6	97.6
2	3	046E	64	55.3	75.9
2	5	04AC	64	49.9	89.1
3	3	066D	64	52.5	82
4	3	086C	64	49.9	89.1
5	3	0A6B	64	47.6	97.6
1	3	026F	60	54.9	66.1
1	5	02AE	60	51.9	71

Modulation Degree (k)	Random No (N)	CMPR [hex]	Baseclk [MHz]	Fmin [MHz]	Fmax [MHz]
1	7	02ED	60	49.3	76.7
1	9	032C	60	46.9	83.3
1	11	036B	60	44.7	91.3
2	3	046E	60	51.9	71
2	5	04AC	60	46.9	83.3
3	3	066D	60	49.3	76.7
4	3	086C	60	46.9	83.3
5	3	0A6B	60	44.7	91.3
1	3	026F	56	51.4	61.6
1	5	02AE	56	48.6	66.1
1	7	02ED	56	46.1	71.4
1	9	032C	56	43.8	77.6
1	11	036B	56	41.8	84.9
1	13	03AA	56	39.9	93.8
2	3	046E	56	48.6	66.1
2	5	04AC	56	43.8	77.6
2	7	04EA	56	39.9	93.8
3	3	066D	56	46.1	71.4
3	5	06AA	56	39.9	93.8
4	3	086C	56	43.8	77.6
5	3	0A6B	56	41.8	84.9
6	3	0C6A	56	39.9	93.8
1	3	026F	52	47.8	57
1	5	02AE	52	45.2	61.2
1	7	02ED	52	42.9	66.1
1	9	032C	52	40.8	71.8
1	11	036B	52	38.8	78.6
1	13	03AA	52	37.1	86.8
1	15	03E9	52	35.5	96.9
2	3	046E	52	45.2	61.2
2	5	04AC	52	40.8	71.8
2	7	04EA	52	37.1	86.8
3	3	066D	52	42.9	66.1
3	5	06AA	52	37.1	86.8
4	3	086C	52	40.8	71.8
5	3	0A6B	52	38.8	78.6
6	3	0C6A	52	37.1	86.8
7	3	0E69	52	35.5	96.9
1	3	026F	48	44.2	52.5
1	5	02AE	48	41.8	56.4

Modulation Degree (k)	Random No (N)	CMPR [hex]	Baseclk [MHz]	Fmin [MHz]	Fmax [MHz]
1	7	02ED	48	39.6	60.9
1	9	032C	48	37.7	66.1
1	11	036B	48	35.9	72.3
1	13	03AA	48	34.3	79.9
1	15	03E9	48	32.8	89.1
2	3	046E	48	41.8	56.4
2	5	04AC	48	37.7	66.1
2	7	04EA	48	34.3	79.9
3	3	066D	48	39.6	60.9
3	5	06AA	48	34.3	79.9
4	3	086C	48	37.7	66.1
5	3	0A6B	48	35.9	72.3
6	3	0C6A	48	34.3	79.9
7	3	0E69	48	32.8	89.1
1	3	026F	44	40.6	48.1
1	5	02AE	44	38.4	51.6
1	7	02ED	44	36.4	55.7
1	9	032C	44	34.6	60.4
1	11	036B	44	33	66.1
1	13	03AA	44	31.5	73
1	15	03E9	44	30.1	81.4
2	3	046E	44	38.4	51.6
2	5	04AC	44	34.6	60.4
2	7	04EA	44	31.5	73
2	9	0528	44	28.9	92.1
3	3	066D	44	36.4	55.7
3	5	06AA	44	31.5	73
4	3	086C	44	34.6	60.4
4	5	08A8	44	28.9	92.1
5	3	0A6B	44	33	66.1
6	3	0C6A	44	31.5	73
7	3	0E69	44	30.1	81.4
8	3	1068	44	28.9	92.1
1	3	026F	40	37	43.6
1	5	02AE	40	34.9	46.8
1	7	02ED	40	33.1	50.5
1	9	032C	40	31.5	54.8
1	11	036B	40	30	59.9
1	13	03AA	40	28.7	66.1
1	15	03E9	40	27.4	73.7

Modulation Degree (k)	Random No (N)	CMPR [hex]	Baseclk [MHz]	Fmin [MHz]	Fmax [MHz]
2	3	046E	40	34.9	46.8
2	5	04AC	40	31.5	54.8
2	7	04EA	40	28.7	66.1
2	9	0528	40	26.3	83.3
3	3	066D	40	33.1	50.5
3	5	06AA	40	28.7	66.1
3	7	06E7	40	25.3	95.8
4	3	086C	40	31.5	54.8
4	5	08A8	40	26.3	83.3
5	3	0A6B	40	30	59.9
6	3	0C6A	40	28.7	66.1
7	3	0E69	40	27.4	73.7
8	3	1068	40	26.3	83.3
9	3	1267	40	25.3	95.8
1	3	026F	36	33.3	39.2
1	5	02AE	36	31.5	42
1	7	02ED	36	29.9	45.3
1	9	032C	36	28.4	49.2
1	11	036B	36	27.1	53.8
1	13	03AA	36	25.8	59.3
1	15	03E9	36	24.7	66.1
2	3	046E	36	31.5	42
2	5	04AC	36	28.4	49.2
2	7	04EA	36	25.8	59.3
2	9	0528	36	23.7	74.7
3	3	066D	36	29.9	45.3
3	5	06AA	36	25.8	59.3
3	7	06E7	36	22.8	85.8
4	3	086C	36	28.4	49.2
4	5	08A8	36	23.7	74.7
5	3	0A6B	36	27.1	53.8
6	3	0C6A	36	25.8	59.3
7	3	0E69	36	24.7	66.1
8	3	1068	36	23.7	74.7
9	3	1267	36	22.8	85.8
1	3	026F	32	29.7	34.7
1	5	02AE	32	28	37.3
1	7	02ED	32	26.6	40.2
1	9	032C	32	25.3	43.6
1	11	036B	32	24.1	47.7

Modulation Degree (k)	Random No (N)	CMPR [hex]	Baseclk [MHz]	Fmin [MHz]	Fmax [MHz]
1	13	03AA	32	23	52.5
1	15	03E9	32	22	58.6
2	3	046E	32	28	37.3
2	5	04AC	32	25.3	43.6
2	7	04EA	32	23	52.5
2	9	0528	32	21.1	66.1
2	11	0566	32	19.5	89.1
3	3	066D	32	26.6	40.2
3	5	06AA	32	23	52.5
3	7	06E7	32	20.3	75.9
4	3	086C	32	25.3	43.6
4	5	08A8	32	21.1	66.1
5	3	0A6B	32	24.1	47.7
5	5	0AA6	32	19.5	89.1
6	3	0C6A	32	23	52.5
7	3	0E69	32	22	58.6
8	3	1068	32	21.1	66.1
9	3	1267	32	20.3	75.9
10	3	1466	32	19.5	89.1

21. Electrical Characteristics

21.1 Absolute maximum ratings

Parameter	Symbol	Rating		Unit	Remarks
		Min	Max		
Power supply slew rate	—	—	50	V/ms	
Power supply voltage 1* ¹	V _{DD5R}	- 0.3	+ 6.0	V	
Power supply voltage 2* ¹	V _{DD5}	- 0.3	+ 6.0	V	
Power supply voltage 3* ¹	V _{DD35}	- 0.3	+ 6.0	V	
Relationship of the supply voltages	AV _{CC5}	V _{DD5} -0.3	V _{DD5} +0.3	V	At least one of the pins P07, P16, P20, P24, or P29 (ANn) is used as digital input or output.
		V _{SS5} -0.3	V _{DD5} +0.3	V	All pins of the ports P07, P16, P20, P24, or P29 (ANn) follow the condition of V _{IA}
Analog power supply voltage* ¹	AV _{CC5}	- 0.3	+ 6.0	V	*2
Analog reference power supply voltage* ¹	AVRH	- 0.3	+ 6.0	V	*2
Input voltage 1* ¹	V _{I1}	V _{SS5} - 0.3	V _{DD5} + 0.3	V	
Input voltage 2* ¹	V _{I2}	V _{SS5} - 0.3	V _{DD35} + 0.3	V	External bus
Analog pin input voltage* ¹	V _{IA}	AV _{SS5} - 0.3	AV _{CC5} + 0.3	V	
Output voltage 1* ¹	V _{O1}	V _{SS5} - 0.3	V _{DD5} + 0.3	V	
Output voltage 2* ¹	V _{O2}	V _{SS5} - 0.3	V _{DD35} + 0.3	V	External bus
Maximum clamp current	I _{CLAMP}	- 4.0	+ 4.0	mA	*3
Total maximum clamp current	∑ I _{CLAMP}	—	20	mA	*3
“L” level maximum output current* ⁴	I _{OL}	—	10	mA	
“L” level average output current* ⁵	I _{OLAV}	—	8	mA	
“L” level total maximum output current	∑ I _{OL}	—	100	mA	
“L” level total average output current* ⁶	∑ I _{OLAV}	—	50	mA	
“H” level maximum output current* ⁴	I _{OH}	—	- 10	mA	
“H” level average output current* ⁵	I _{OHAV}	—	- 4	mA	
“H” level total maximum output current	∑ I _{OH}	—	- 100	mA	
“H” level total average output current* ⁶	∑ I _{OHAV}	—	- 25	mA	
Permitted operating frequency	f _{max, CLKB}	—	100	MHz	T _A ≤ 105 °C
	f _{max, CLKP}	—	50		
	f _{max, CLKT}	—	50		
	f _{max, CLKCAN}	—	50		

Parameter	Symbol	Rating		Unit	Remarks
		Min	Max		
Permitted operating frequency	$f_{\max, CLKB}$	—	96	MHz	$T_A \leq 125\text{ }^\circ\text{C}$
	$f_{\max, CLKP}$	—	48		
	$f_{\max, CLKT}$	—	48		
	$f_{\max, CLKCAN}$	—	48		
Permitted power dissipation ^{*7}	P_D	—	1250 ^{*8}	mW	$T_A \leq 85\text{ }^\circ\text{C}$
		—	630 ^{*8}	mW	$T_A \leq 105\text{ }^\circ\text{C}$
		—	1400 ^{*8}	mW	$T_A \leq 105\text{ }^\circ\text{C}$, no Flash program/erase ^{*9}
		—	1100 ^{*8}	mW	$T_A \leq 115\text{ }^\circ\text{C}$, no Flash program/erase ^{*9}
		—	780 ^{*8}	mW	$T_A \leq 125\text{ }^\circ\text{C}$, no Flash program/erase ^{*9}
Operating temperature	T_A	- 40	+ 125	$^\circ\text{C}$	
Storage temperature	T_{stg}	- 55	+ 150	$^\circ\text{C}$	

*1 : The parameter is based on $V_{SS5} = AV_{SS5} = 0.0\text{ V}$.

*2 : AV_{CC5} and $AVRH5$ must not exceed $V_{DD5} + 0.3\text{ V}$.

*3 : • Use within recommended operating conditions.

- Use with DC voltage (current).
- +B signals are input signals that exceed the V_{DD5} voltage. +B signals should always be applied by connecting a limiting resistor between the +B signal and the microcontroller.
- The value of the limiting resistor should be set so that the current input to the microcontroller pin does not exceed the rated value at any time, either instantaneously or for an extended period, when the +B signal is input.
- Note that when the microcontroller drive current is low, such as in the low power consumption modes, the +B input potential can increase the potential at the power supply pin via a protective diode, possibly affecting other devices.
- Note that if the +B signal is input when the microcontroller is off (not fixed at 0 V), power is supplied through the +B input pin; therefore, the microcontroller may partially operate.
- Note that if the +B signal is input at power-on, since the power is supplied through the pin, the power-on reset may not function in the power supply voltage.

- Do not leave +B input pins open.
- Example of recommended circuit :

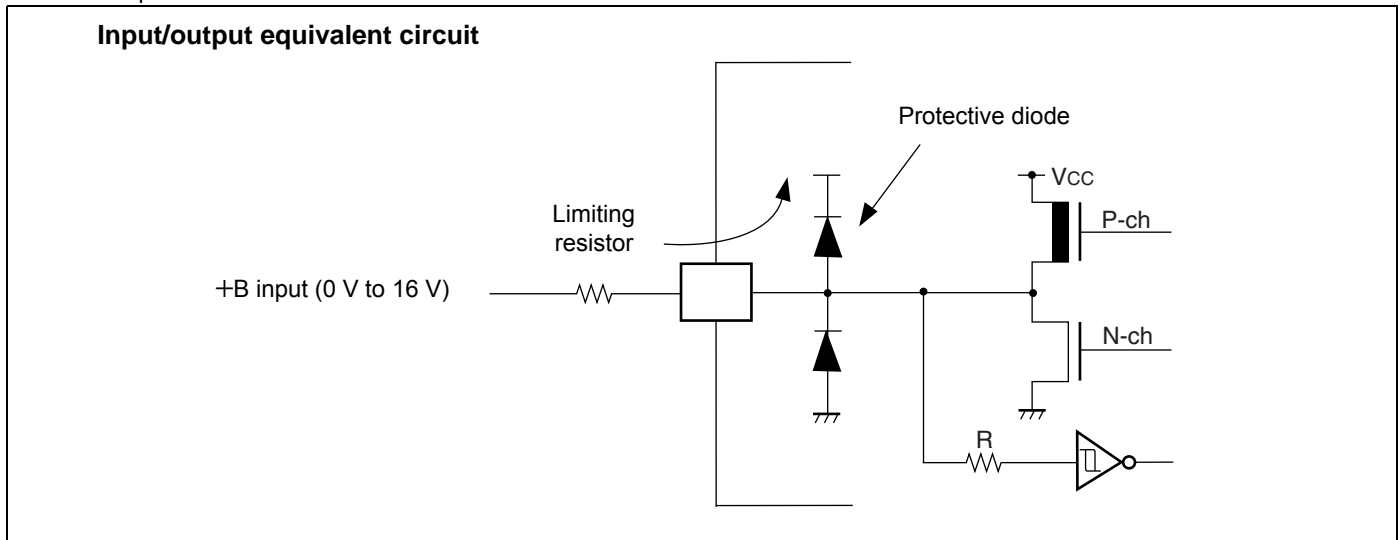

- *4 : Maximum output current is defined as the value of the peak current flowing through any one of the corresponding pins.
- *5 : Average output current is defined as the value of the average current flowing through any one of the corresponding pins for a 100 ms period.
- *6 : Total average output current is defined as the value of the average current flowing through all of the corresponding pins for a 100 ms period.
- *7 : The maximum permitted power dissipation depends on the ambient temperature, the air flow velocity and the thermal conductance of the package on the PCB.

The actual power dissipation depends on the customer application and can be calculated as follows:

$$P_D = P_{IO} + P_{INT}$$

$$P_{IO} = \sum (V_{OL} * I_{OL} + V_{OH} * I_{OH}) \text{ (IO load power dissipation, sum is performed on all IO ports)}$$

$$P_{INT} = V_{DD5R} * I_{CC} + AV_{CC5} * I_A + AVR_{H5} * I_R \text{ (internal power dissipation)}$$

- *8 : Worst case value for the QFP package mounted on a 4-layer PCB at specified T_A without air flow.
- *9 : Please contact Cypress for reliability limitations when using under these conditions.

WARNING: Semiconductor devices can be permanently damaged by application of stress (voltage, current, temperature, etc.) in excess of absolute maximum ratings. Do not exceed these ratings.

21.2 Recommended operating conditions
 $(V_{SS5} = AV_{SS5} = 0.0\text{ V})$

Parameter	Symbol	Value			Unit	Remarks
		Min	Typ	Max		
Power supply voltage	V_{DD5}	3.0	—	5.5	V	
	V_{DD5R}	3.0	—	5.5	V	Internal regulator
	V_{DD35}	3.0	—	5.5	V	External bus
	AV_{CC5}	3.0	—	5.5	V	A/D converter
Smoothing capacitor at VCC18C pin	C_S	—	4.7	—	μF	Use a X7R ceramic capacitor or a capacitor that has similar frequency characteristics.
Power supply slew rate		—	—	50	V/ms	
Main Oscillation stabilisation time		10			ms	
Lock-up time PLL (4 MHz -> 16 ... 100MHz)				0.6	ms	
ESD Protection (Human body model)	V_{surge}	2			kV	$R_{discharge} = 1.5\text{k}\Omega$ $C_{discharge} = 100\text{pF}$
RC Oscillator	$f_{RC100\text{kHz}}$ $f_{RC2\text{MHz}}$	50 1	100 2	200 4	kHz MHz	$V_{DDCORE} \geq 1.65\text{V}$

WARNING: The recommended operating conditions are required in order to ensure the normal operation of the semiconductor device. All of the device's electrical characteristics are warranted when the device is operated within these ranges. Always use semiconductor devices within their recommended operating condition ranges. Operation outside these ranges may adversely affect reliability and could result in device failure. No warranty is made with respect to uses, operating conditions, or combinations not represented on the data sheet. Users considering application outside the listed conditions are advised to contact their representatives beforehand.

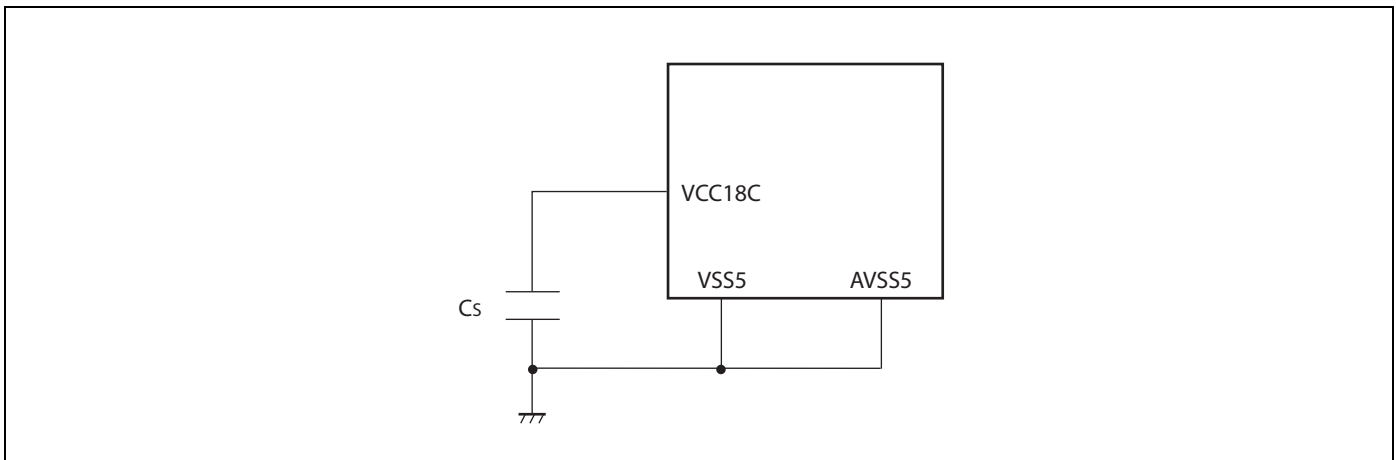

21.3 DC characteristics

Note: In the following tables, “V_{DD}” means V_{DD35} for pins of ext. bus or V_{DD5} for other pins.

In the following tables, “V_{SS}” means ground Pins V_{SS5} for the other pins.

(V_{DD5} = AV_{CC5} = 3.0 V to 5.5 V, V_{SS5} = AV_{SS5} = 0 V, T_A = -40 °C to + 125 °C)

Parameter	Symbol	Pin name	Condition	Value			Unit	Remarks
				Min	Typ	Max		
Input “H” voltage	V _{IH}	—	Port inputs if CMOS Hysteresis 0.8/0.2 input is selected	0.8 × V _{DD}	—	V _{DD} + 0.3	V	CMOS hysteresis input
		—	Port inputs if CMOS Hysteresis 0.7/0.3 input is selected	0.7 × V _{DD}	—	V _{DD} + 0.3	V	4.5 V ≤ V _{DD} ≤ 5.5 V
				0.74 × V _{DD}	—	V _{DD} + 0.3	V	3 V ≤ V _{DD} < 4.5 V
		—	AUTOMOTIVE Hysteresis input is selected	0.8 × V _{DD}	—	V _{DD} + 0.3	V	
	—	Port inputs if TTL input is selected	2.0	—	V _{DD} + 0.3	V		
	V _{IHR}	INITX	—	0.8 × V _{DD}	—	V _{DD} + 0.3	V	INITX input pin (CMOS Hysteresis)
	V _{IHM}	MD_2 to MD_0	—	V _{DD} - 0.3	—	V _{DD} + 0.3	V	Mode input pins
	V _{IHX0S}	X0, X0A	—	2.5	—	V _{DD} + 0.3	V	External clock in “Oscillation mode”
V _{IHX0F}	X0	—	0.8 × V _{DD}	—	V _{DD} + 0.3	V	External clock in “Fast Clock Input mode”	
Input “L” voltage	V _{IL}	—	Port inputs if CMOS Hysteresis 0.8/0.2 input is selected	V _{SS} - 0.3	—	0.2 × V _{DD}	V	
		—	Port inputs if CMOS Hysteresis 0.7/0.3 input is selected	V _{SS} - 0.3	—	0.3 × V _{DD}	V	
		—	Port inputs if AUTOMOTIVE Hysteresis input is selected	V _{SS} - 0.3	—	0.5 × V _{DD}	V	4.5 V ≤ V _{DD} ≤ 5.5 V
				V _{SS} - 0.3	—	0.46 × V _{DD}	V	3 V ≤ V _{DD} < 4.5 V
	—	Port inputs if TTL input is selected	V _{SS} - 0.3	—	0.8	V		
	V _{ILR}	INITX	—	V _{SS} - 0.3	—	0.2 × V _{DD}	V	INITX input pin (CMOS Hysteresis)
	V _{ILM}	MD_2 to MD_0	—	V _{SS} - 0.3	—	V _{SS} + 0.3	V	Mode input pins
	V _{ILXDS}	X0, X0A	—	V _{SS} - 0.3	—	0.5	V	External clock in “Oscillation mode”

$(V_{DD5} = AV_{CC5} = 3.0\text{ V to } 5.5\text{ V}, V_{SS5} = AV_{SS5} = 0\text{ V}, T_A = -40\text{ }^\circ\text{C to } +125\text{ }^\circ\text{C})$

Parameter	Symbol	Pin name	Condition	Value			Unit	Remarks
				Min	Typ	Max		
Input "L" voltage	V_{ILXDF}	X0	—	$V_{SS} - 0.3$	—	$0.2 \times V_{DD}$	V	External clock in "Fast Clock Input mode"
Output "H" voltage	V_{OH2}	Normal outputs	$4.5\text{V} \leq V_{DD} \leq 5.5\text{V}, I_{OH} = -2\text{mA}$	$V_{DD} - 0.5$	—	—	V	Driving strength set to 2 mA
			$3.0\text{V} \leq V_{DD} \leq 4.5\text{V}, I_{OH} = -1.6\text{mA}$					
	V_{OH5}	Normal outputs	$4.5\text{V} \leq V_{DD} \leq 5.5\text{V}, I_{OH} = -5\text{mA}$	$V_{DD} - 0.5$	—	—	V	Driving strength set to 5 mA
$3.0\text{V} \leq V_{DD} \leq 4.5\text{V}, I_{OH} = -3\text{mA}$								
	V_{OH3}	I ² C outputs	$3.0\text{V} \leq V_{DD} \leq 5.5\text{V}, I_{OH} = -3\text{mA}$	$V_{DD} - 0.5$	—	—	V	
Output "L" voltage	V_{OL2}	Normal outputs	$4.5\text{V} \leq V_{DD} \leq 5.5\text{V}, I_{OL} = +2\text{mA}$	—	—	0.4	V	Driving strength set to 2 mA
			$3.0\text{V} \leq V_{DD} \leq 4.5\text{V}, I_{OL} = +1.6\text{mA}$					
	V_{OL5}	Normal outputs	$4.5\text{V} \leq V_{DD} \leq 5.5\text{V}, I_{OL} = +5\text{mA}$	—	—	0.4	V	Driving strength set to 5 mA
$3.0\text{V} \leq V_{DD} \leq 4.5\text{V}, I_{OL} = +3\text{mA}$								
	V_{OL3}	I ² C outputs	$3.0\text{V} \leq V_{DD} \leq 5.5\text{V}, I_{OL} = +3\text{mA}$	—	—	0.4	V	
Input leakage current	I_{IL}	Pnn_m*1	$3.0\text{V} \leq V_{DD} \leq 5.5\text{V}, V_{SS5} < V_I < V_{DD}, T_A = 25\text{ }^\circ\text{C}$	-1	—	+1	μA	
			$3.0\text{V} \leq V_{DD} \leq 5.5\text{V}, V_{SS5} < V_I < V_{DD}, T_A = 125\text{ }^\circ\text{C}$	-3	—	+3		
Analog input leakage current	I_{AIN}	ANn*2	$3.0\text{V} \leq V_{DD} \leq 5.5\text{V}, T_A = 25\text{ }^\circ\text{C}$	-1	—	+1	μA	
			$3.0\text{V} \leq V_{DD} \leq 5.5\text{V}, T_A = 125\text{ }^\circ\text{C}$	-3	—	+3	μA	
Pull-up resistance	R_{UP}	Pnn_m*3, INITX	$3.0\text{V} \leq V_{DD} \leq 3.6\text{V}$	40	100	160	kΩ	
			$4.5\text{V} \leq V_{DD} \leq 5.5\text{V}$	25	50	100		
Pull-down resistance	R_{DOWN}	Pnn_m*4	$3.0\text{V} \leq V_{DD} \leq 3.6\text{V}$	40	100	180	kΩ	
			$4.5\text{V} \leq V_{DD} \leq 5.5\text{V}$	25	50	100		
Input capacitance	C_{IN}	All except $V_{DD5}, V_{DD5R}, V_{SS5}, AV_{CC5}, AV_{SS5}, AVRH5$	$f = 1\text{ MHz}$	-	5	15	pF	

Parameter	Symbol	Pin name	Condition	Value			Unit	Remarks
				Min	Typ	Max		
Power supply current CY91-F465PA	I _{CC}	V _{DD5R}	CLKB: 100 MHz CLKP: 50 MHz CLKT: 50 MHz CLKCAN: 50 MHz	-	110	140	mA	Code fetch from Flash
	I _{CCH}	V _{DD5R}	T _A = + 25 °C	-	30	150	μA	At stop mode *5
			T _A = + 105 °C	-	0.3	2.0	mA	
			T _A = + 125 °C	-	0.75	5.0	mA	
			T _A = + 25 °C	-	100	500	μA	RTC : 4 MHz mode *5
			T _A = + 105 °C	-	0.5	2.4	mA	
			T _A = + 125 °C	-	0.85	5.4	mA	
			T _A = + 25 °C	-	50	250	μA	RTC : 100 kHz mode *5
			T _A = + 105 °C	-	0.4	2.2	mA	
	T _A = + 125 °C	-	0.8	5.2	mA			
	I _{LVE}	V _{DD5}	—	—	70	150	μA	External low voltage detection
I _{LVI}	V _{DD5R}	—	—	50	100	μA	Internal low voltage detection	
I _{OSC}	V _{DD5}	-	-	250	500	μA	Main clock (4 MHz)	
		-	-	20	40	μA	Sub clock (32 kHz)	
Power supply current CY91-F467PA *6	I _{CC}	V _{DD5R}	CLKB: 100 MHz CLKP: 50 MHz CLKT: 50 MHz CLKCAN: 50 MHz	-	130	160	mA	Code fetch from Flash, Data Flash enabled
	I _{CCH}	V _{DD5R}	T _A = + 25 °C	-	30	150	μA	At stop mode *7
			T _A = + 105 °C	-	0.3	2.0	mA	
			T _A = + 125 °C	-	0.75	5.0	mA	
			T _A = + 25 °C	-	100	500	μA	RTC : 4 MHz mode
			T _A = + 105 °C	-	0.5	2.4	mA	
			T _A = + 125 °C	-	0.85	5.4	mA	
			T _A = + 25 °C	-	50	250	μA	RTC : 100 kHz mode
			T _A = + 105 °C	-	0.4	2.2	mA	
	T _A = + 125 °C	-	0.8	5.2	mA			
	I _{LVE}	V _{DD5}	—	—	70	150	μA	External low voltage detection
I _{LVI}	V _{DD5R}	—	—	50	100	μA	Internal low voltage detection	
I _{OSC}	V _{DD5}	-	-	250	500	μA	Main clock (4 MHz)	
		-	-	20	40	μA	Sub clock (32 kHz)	

1. Pnn_m includes all GPIO pins. Analog (AN) channels and PullUp/PullDown are disabled.

2. ANn includes all pins where AN channels are enabled.

3. Pnn_m includes all GPIO pins. The pull up resistors must be enabled by PPER/PPCR setting and the pins must be in input direction.

4. Pnn_m includes all GPIO pins. The pull down resistors must be enabled by PPER/PPCR setting and the pins must be in input direction.
5. Main regulator OFF, sub regulator set to 1.2V, Low voltage detection disabled.
6. CY91F467PA target data
7. Main regulator OFF, sub regulator set to 1.2V, Low voltage detection disabled.

21.4 A/D converter characteristics
 $(V_{DD5} = AV_{CC5} = 3.0\text{ V to }5.5\text{ V}, V_{SS5} = AV_{SS5} = 0\text{ V}, T_A = -40\text{ }^{\circ}\text{C to }+125\text{ }^{\circ}\text{C})$

Parameter	Symbol	Pin name	Value			Unit	Remarks
			Min	Typ	Max		
Resolution	—	—	—	—	10	bit	
Total error	—	—	- 3	—	+ 3	LSB	
Nonlinearity error	—	—	- 2.5	—	+ 2.5	LSB	
Differential nonlinearity error	—	—	- 1.9	—	+ 1.9	LSB	
Zero reading voltage	V_{OT}	ANn	AVRL-1.5 LSB	AVRL + 0.5 LSB	AVRL + 2.5 LSB	V	
Full scale reading voltage	V_{FST}	ANn	AVRH-3.5 LSB	AVRH-1.5 LSB	AVRH + 0.5 LSB	V	
Compare time	T_{comp}	—	0.6	—	16,500	μs	$4.5\text{ V} \leq AV_{CC5} \leq 5.5\text{ V}$
			2.0	—	—	μs	$3.0\text{ V} \leq AV_{CC5} \leq 4.5\text{ V}$
Sampling time	T_{samp}	—	0.4	—	—	μs	$4.5\text{ V} \leq AV_{CC5} \leq 5.5\text{ V},$ $R_{EXT} < 2\text{ k}\Omega$
			1.0	—	—	μs	$3.0\text{ V} \leq AV_{CC5} \leq 4.5\text{ V},$ $R_{EXT} < 1\text{ k}\Omega$
Conversion time	T_{conv}	—	1.0	—	—	μs	$4.5\text{ V} \leq AV_{CC5} \leq 5.5\text{ V}$
			3.0	—	—	μs	$3.0\text{ V} \leq AV_{CC5} \leq 4.5\text{ V}$
Input capacitance	C_{IN}	ANn	—	—	11	pF	
Input resistance	R_{IN}	ANn	—	—	2.6	k Ω	$4.5\text{ V} \leq AV_{CC5} \leq 5.5\text{ V}$
			—	—	12.1	k Ω	$3.0\text{ V} \leq AV_{CC5} \leq 4.5\text{ V}$
Analog input leakage current	I_{AIN}	ANn	- 1	—	+ 1	μA	$T_A = +25\text{ }^{\circ}\text{C}$
			- 3	—	+ 3	μA	$T_A = +125\text{ }^{\circ}\text{C}$
Analog input voltage range	V_{AIN}	ANn	AVRL	—	AVRH	V	
Offset between input channels	—	ANn	—	—	4	LSB	

(Continued)

Note : The accuracy gets worse as AVRH - AVRL becomes smaller

(Continued)

Parameter	Symbol	Pin name	Value			Unit	Remarks
			Min	Typ	Max		
Reference voltage range	AVRH	AVRH5	$0.75 \times AV_{CC5}$	—	AV_{CC5}	V	
	AVRL	AV _{SS5}	AV_{SS5}	—	$AV_{CC5} \times 0.25$	V	
Power supply current per ADC macro * ³	I _A	AV _{CC5}	—	2.5	5	mA	A/D Converter active
	I _{AH}	AV _{CC5}	—	—	5	μA	A/D Converter not operated * ¹
Reference voltage current per ADC macro * ³	I _R	AVRH5	—	0.7	1	mA	A/D Converter active
	I _{RH}	AVRH5	—	—	5	μA	A/D Converter not operated * ²

*¹ : Supply current at AV_{CC5}, if A/D converter and ALARM comparator are not operating, (V_{DD5} = AV_{CC5} = AVRH = 5.0 V)

*² : Input current at AVRH5, if A/D converter is not operating, (V_{DD5} = AV_{CC5} = AVRH = 5.0 V)

*³ : The current consumption per ADC macro is given here. On devices having more than one A/D converter, the current values have to be multiplied by the number of macros.

Sampling Time Calculation

$$T_{\text{samp}} = (2.6 \text{ k}\Omega + R_{\text{EXT}}) \times 11\text{pF} \times 7; \text{ for } 4.5\text{V} \leq AV_{CC5} \leq 5.5\text{V}$$

$$T_{\text{samp}} = (12.1 \text{ k}\Omega + R_{\text{EXT}}) \times 11\text{pF} \times 7; \text{ for } 3.0\text{V} \leq AV_{CC5} \leq 4.5\text{V}$$

Conversion Time Calculation

$$T_{\text{conv}} = T_{\text{samp}} + T_{\text{comp}}$$

Definition of A/D converter terms

- Resolution
Analog variation that is recognizable by the A/D converter.
- Nonlinearity error
Deviation between actual conversion characteristics and a straight line connecting the zero transition point (00 0000 0000_B ↔ 00 0000 0001_B) and the full scale transition point (11 1111 1110_B ↔ 11 1111 1111_B).
- Differential nonlinearity error
Deviation of the input voltage from the ideal value that is required to change the output code by 1 LSB.
- Total error
This error indicates the difference between actual and theoretical values, including the zero transition error, full scale transition error, and nonlinearity error.

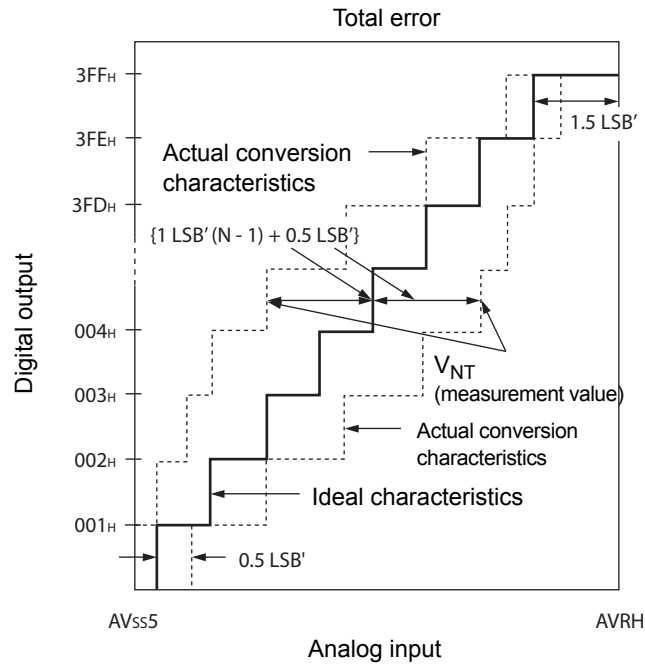

$$1\text{LSB}' \text{ (ideal value)} = \frac{\text{AVRH} - \text{AV}_{\text{SS5}}}{1024} \text{ [V]}$$

$$\text{Total error of digital output N} = \frac{V_{\text{NT}} - \{1\text{LSB}' \times (N - 1) + 0.5\text{LSB}'\}}{1\text{LSB}'}$$

N : A/D converter digital output value

$$V_{\text{OT}}' \text{ (ideal value)} = \text{AV}_{\text{SS5}} + 0.5\text{LSB}' \text{ [V]}$$

$$V_{\text{FST}}' \text{ (ideal value)} = \text{AVRH} - 1.5\text{LSB}' \text{ [V]}$$

V_{NT} : Voltage at which the digital output changes from (N + 1)_H to N_H

(Continued)

(Continued)

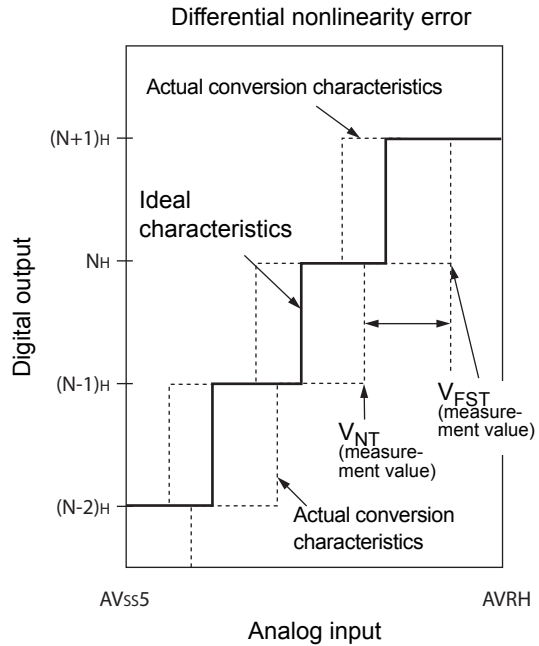
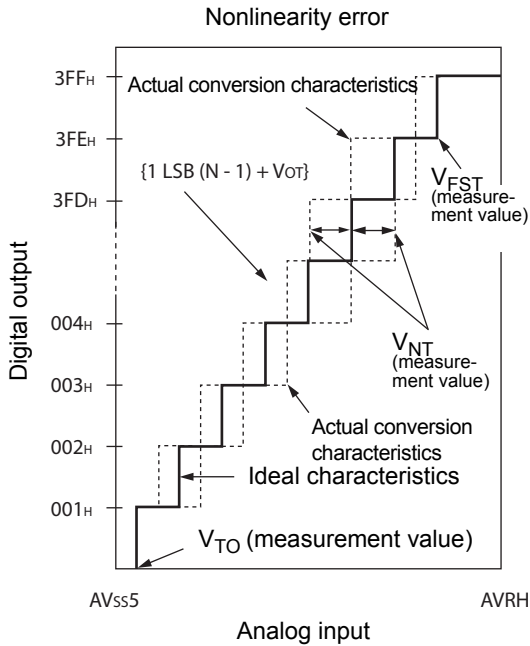

$$\text{Nonlinearity error of digital output } N = \frac{V_{NT} - \{1\text{LSB} \times (N - 1) + V_{OT}\}}{1\text{LSB}} \text{ [LSB]}$$

$$\text{Differential nonlinearity error of digital output } N = \frac{V_{(N+1)T} - V_{NT}}{1\text{LSB}} - 1 \text{ [LSB]}$$

$$1\text{LSB} = \frac{V_{FST} - V_{OT}}{1022} \text{ [V]}$$

N : A/D converter digital output value

V_{OT} : Voltage at which the digital output changes from 000_H to 001_H.

V_{FST} : Voltage at which the digital output changes from 3FE_H to 3FF_H.

21.5 FLASH memory program/erase characteristics
21.5.1 CY91F465PA
 $(V_{DD5} = 3.0 \text{ V to } 5.5 \text{ V}, V_{DD5R} = 3.0 \text{ V to } 5.5 \text{ V}, V_{SS5} = 0 \text{ V}, T_A = -40 \text{ }^\circ\text{C to } +105 \text{ }^\circ\text{C})$

Parameter	Value			Unit	Remarks
	Min	Typ	Max		
Sector erase time	-	0.9	3.6	s	Erasure programming time not included
Chip erase time	-	n*0.9	n*3.6	s	n is the number of Flash sector of the device
Word (16-bit width) programming time	-	23	370	μs	System overhead time not included
Programme/Erase cycle	10 000			cycle	
Flash data retention time	20			year	*1

*1: This value was converted from the results of evaluating the reliability of the technology (using Arrhenius equation to convert high temperature measurements into normalized value at 85°C)

21.5.2 CY91F467PA
 $(V_{DD5} = 3.0 \text{ V to } 5.5 \text{ V}, V_{DD5R} = 3.0 \text{ V to } 5.5 \text{ V}, V_{SS5} = 0 \text{ V}, T_A = -40 \text{ }^\circ\text{C to } +105 \text{ }^\circ\text{C})$

Parameter	Value			Unit	Remarks
	Min	Typ	Max		
Sector erase time	-	0.5	2.0	s	Erasure programming time not included
Chip erase time	-	n*0.5	n*2.0	s	n is the number of Flash sector of the device
Word (16 or 32-bit width) programming time	-	6	100	μs	System overhead time not included
Program/Erase cycle	10 000			cycle	
Flash data retention time	20			year	*1

*1: This value was converted from the results of evaluating the reliability of the technology (using Arrhenius equation to convert high temperature measurements into normalized value at 85°C)

21.5.3 CY91F467PA DATA FLASH

 (V_{DD5} = 3.0 V to 5.5 V, V_{DD5R} = 3.0 V to 5.5 V, V_{SS5} = 0 V, T_A = -40 °C to + 105 °C)

Parameter	Value			Unit	Remarks
	Min	Typ	Max		
Sector erase time	-	0.5	2.0	s	Erase programming time not included
	-	0.8	3.6	s	Erase programming time is included
Byte programming time	-	15	100	µs	System overhead time not included
Word programming time (32bit width command sequencer write *1)	-	63	403	µs	System overhead time is included CLKB = 64 MHz
Program/Erase cycle	100 000			cycle	at T _j < 105 °C / 10,000 cycle at T _j > 105 °C

- The time from CPU write access until the interrupt flag DFWS:FININT is set.
It includes 4 byte programming times + 180 CLKB cycles for write sequence, RDY polling and result verification done by the command sequencer. Does not include the interrupt latency time of the CPU.

21.6 AC characteristics

21.6.1 Clock timing

($V_{DD5} = 3.0\text{ V to } 5.5\text{ V}$, $V_{SS5} = AV_{SS5} = 0\text{ V}$, $T_A = -40\text{ }^\circ\text{C to } +125\text{ }^\circ\text{C}$)

Parameter	Symbol	Pin name	Value			Unit	Condition
			Min	Typ	Max		
Clock frequency	f_C	X0 X1	3.5	4	16	MHz	Opposite phase external supply or crystal
		X0A X1A	32	32.768	100	kHz	

Clock timing condition

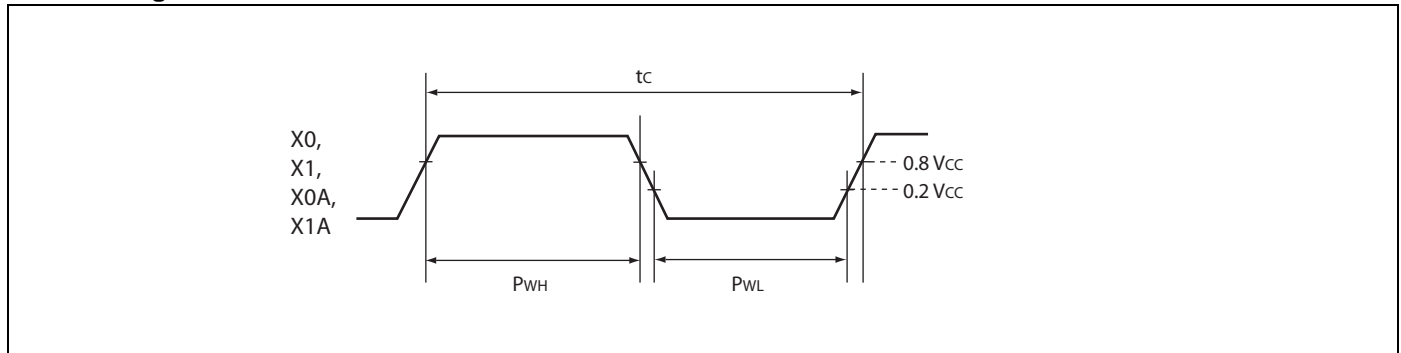

21.6.2 Reset input ratings

($V_{DD5} = 3.0\text{ V to } 5.5\text{ V}$, $V_{SS5} = AV_{SS5} = 0\text{ V}$, $T_A = -40\text{ }^\circ\text{C to } +125\text{ }^\circ\text{C}$)

Parameter	Symbol	Pin name	Condition	Value		Unit
				Min	Max	
INITX input time (at power-on)	t_{INTL}	INITX	—	8	—	ms
INITX input time (other than the above)				20	—	μs

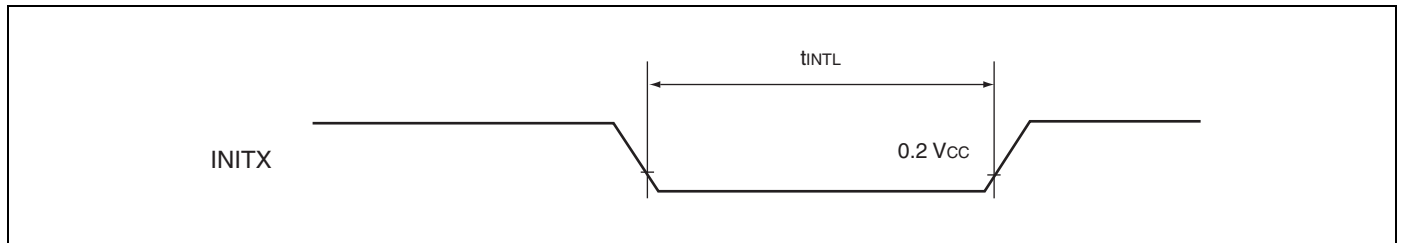

21.6.3 LIN-USART Timings at $V_{DD5} = 3.0$ to 5.5 V

- Conditions during AC measurements

All AC tests were measured under the following conditions:

- $I_{Odrive} = 5$ mA
- $V_{DD5} = 3.0$ V to 5.5 V, $I_{load} = 3$ mA
- $V_{SS5} = 0$ V
- $T_a = -40$ °C to $+125$ °C
- $C_l = 50$ pF (load capacity value of pins when testing)
- $VOL = 0.2 \times V_{DD5}$
- $VOH = 0.8 \times V_{DD5}$
- $EPILR = 0$, $PILR = 1$ (Automotive Level = worst case)

($V_{DD5} = 3.0$ V to 5.5 V, $V_{SS5} = AV_{SS5} = 0$ V, $T_A = -40$ °C to $+125$ °C)

Parameter	Symbol	Pin name	Condition	$V_{DD5} = 3.0$ V to 4.5 V		$V_{DD5} = 4.5$ V to 5.5 V		Unit
				Min	Max	Min	Max	
Serial clock cycle time	t_{SCYCI}	SCKn	Internal clock operation (master mode)	$4 t_{CLKP}$	—	$4 t_{CLKP}$	—	ns
SCK ↓ → SOT delay time	t_{SLOVI}	SCKn SOTn		- 30	30	- 20	20	ns
SOT → SCK ↓ delay time	t_{OVSHI}	SCKn SOTn		$m \times t_{CLKP} - 30^*$	—	$m \times t_{CLKP} - 20^*$	—	ns
Valid SIN → SCK ↑ setup time	t_{IVSHI}	SCKn SINn		$t_{CLKP} + 55$	—	$t_{CLKP} + 45$	—	ns
SCK ↑ → valid SIN hold time	t_{SHIXI}	SCKn SINn		0	—	0	—	ns
Serial clock "H" pulse width	t_{SHSLE}	SCKn	External clock operation (slave mode)	$t_{CLKP} + 10$	—	$t_{CLKP} + 10$	—	ns
Serial clock "L" pulse width	t_{SLSHE}	SCKn		$t_{CLKP} + 10$	—	$t_{CLKP} + 10$	—	ns
SCK ↓ → SOT delay time	t_{SLOVE}	SCKn SOTn		—	$2 t_{CLKP} + 55$	—	$2 t_{CLKP} + 45$	ns
Valid SIN → SCK ↑ setup time	t_{IVSHE}	SCKn SINn		10	—	10	—	ns
SCK ↑ → valid SIN hold time	t_{SHIXE}	SCKn SINn		$t_{CLKP} + 10$	—	$t_{CLKP} + 10$	—	ns
SCK rising time	t_{FE}	SCKn		—	20	—	20	ns
SCK falling time	t_{RE}	SCKn		—	20	—	20	ns

* : Parameter m depends on t_{SCYCI} and can be calculated as :

- if $t_{SCYCI} = 2 \cdot k \cdot t_{CLKP}$, then $m = k$, where k is an integer > 2
- if $t_{SCYCI} = (2 \cdot k + 1) \cdot t_{CLKP}$, then $m = k + 1$, where k is an integer > 1

Notes : • The above values are AC characteristics for CLK synchronous mode.
• t_{CLKP} is the cycle time of the peripheral clock.

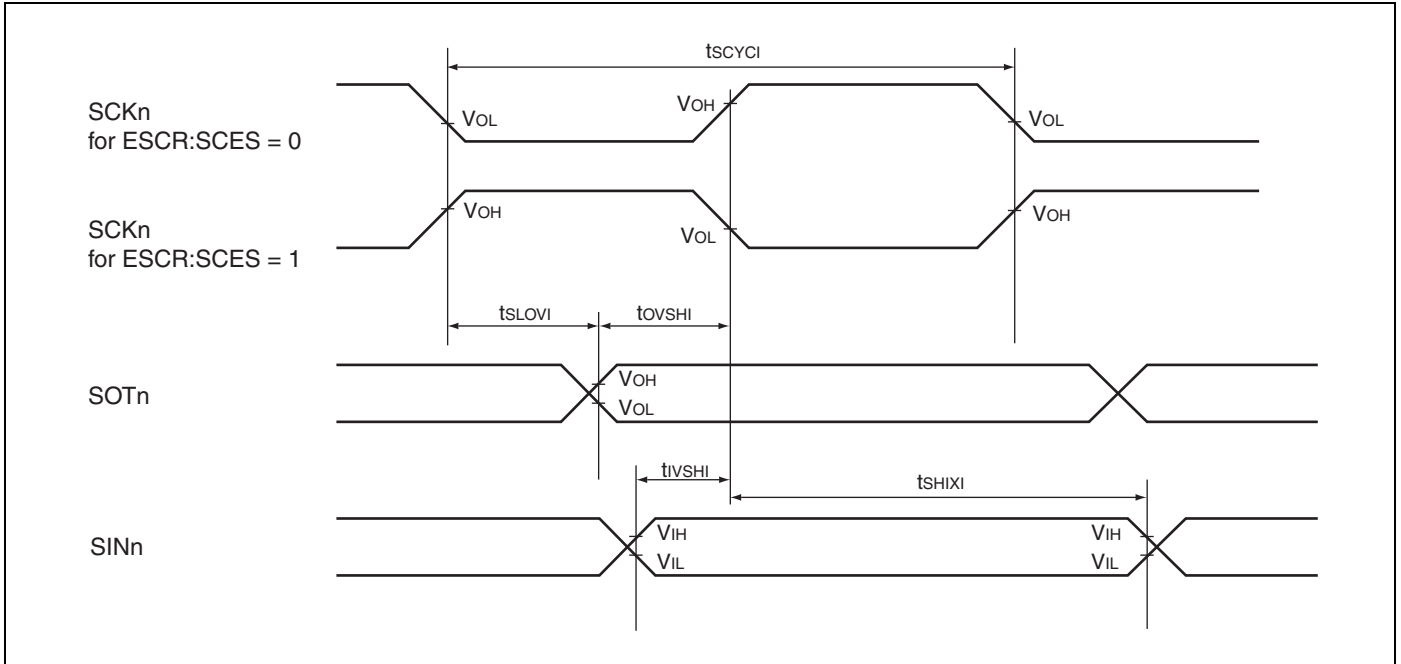
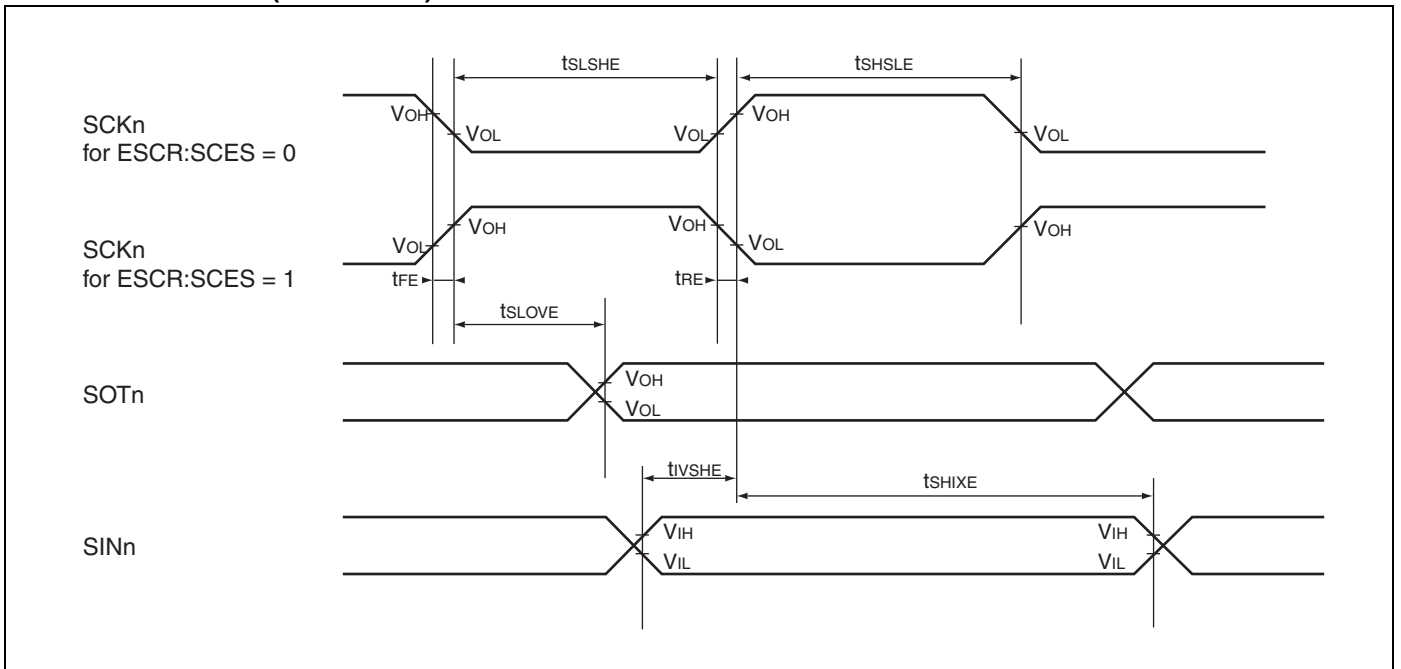
Internal clock mode (master mode)

External clock mode (slave mode)

21.6.4 I²C AC Timings at V_{DD5} = 3.0 to 5.5 V

- Conditions during AC measurements

All AC tests were measured under the following conditions:

- I_{Odrive} = 3 mA
- V_{DD5} = 3.0 V to 5.5 V, I_{load} = 3 mA
- V_{SS5} = 0 V
- T_a = - 40 °C to + 125 °C
- C_l = 50 pF
- VOL = 0.3 × V_{DD5}
- VOH = 0.7 × V_{DD5}
- EPILR = 0, PILR = 0 (CMOS Hysteresis 0.3 × V_{DD5}/0.7 × V_{DD5})

Fast mode:

(V_{DD5} = 3.5 V to 5.5 V, V_{SS5} = AV_{SS5} = 0 V, T_A = -40 °C to + 125 °C)

Parameter	Symbol	Pin name	Value		Unit	Remark
			Min	Max		
SCL clock frequency	f _{SCL}	SCLn	0	400	kHz	
Hold time (repeated) START condition. After this period, the first clock pulse is generated	t _{HD;STA}	SCLn, SDA _n	0.6	—	μs	
LOW period of the SCL clock	t _{LOW}	SCLn	1.3	—	μs	
HIGH period of the SCL clock	t _{HIGH}	SCLn	0.6	—	μs	
Setup time for a repeated START condition	t _{SU;STA}	SCLn, SDA _n	0.6	—	μs	
Data hold time for I ² C-bus devices	t _{HD;DAT}	SCLn, SDA _n	0	0.9	μs	
Data setup time	t _{SU;DAT}	SCLn, SDA _n	100	—	ns	
Rise time of both SDA and SCL signals	t _r	SCLn, SDA _n	20 + 0.1C _b	300	ns	
Fall time of both SDA and SCL signals	t _f	SCLn, SDA _n	20 + 0.1C _b	300	ns	
Setup time for STOP condition	t _{SU;STO}	SCLn, SDA _n	0.6	—	μs	
Bus free time between a STOP and START condition	t _{BUF}	SCLn, SDA _n	1.3	—	μs	
Capacitive load for each bus line	C _b	SCLn, SDA _n	—	400	pF	
Pulse width of spike suppressed by input filter	t _{SP}	SCLn, SDA _n	0	(1..1.5) × t _{CLKP}	ns	*1

*1: The noise filter will suppress single spikes with a pulse width of 0ns and between (1 to 1.5) cycles of peripheral clock, depending on the phase relationship between I²C signals (SDA, SCL) and peripheral clock.

Note: t_{CLKP} is the cycle time of the peripheral clock.

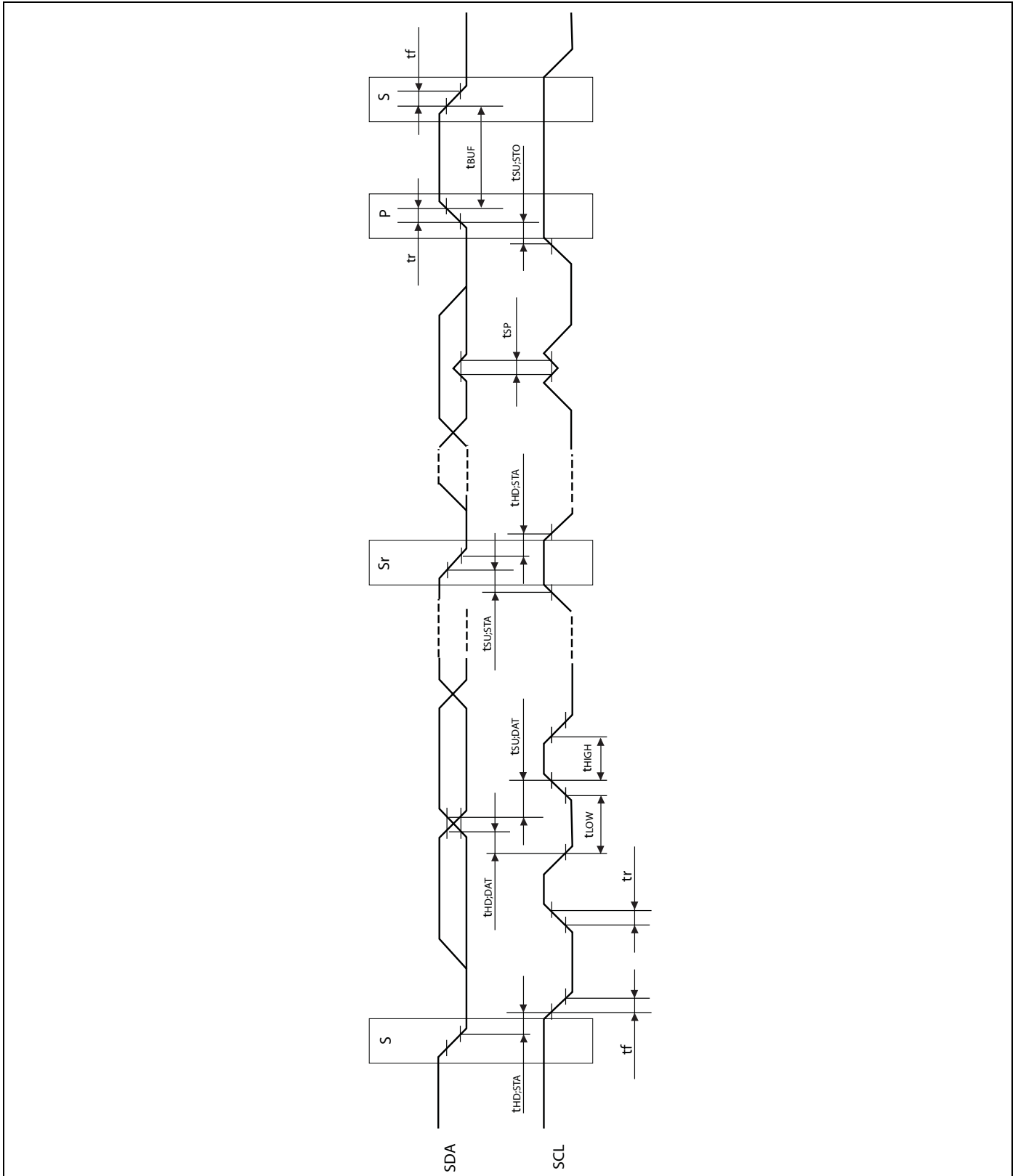

21.6.5 Free-run timer clock

($V_{DD5} = 3.0\text{ V to } 5.5\text{ V}$, $V_{SS5} = AV_{SS5} = 0\text{ V}$, $T_A = -40\text{ }^\circ\text{C to } +125\text{ }^\circ\text{C}$)

Parameter	Symbol	Pin name	Condition	Value		Unit
				Min	Max	
Input pulse width	t_{TIWH} t_{TIWL}	CKn	—	$4t_{CLKP}$	—	ns

Note : t_{CLKP} is the cycle time of the peripheral clock.

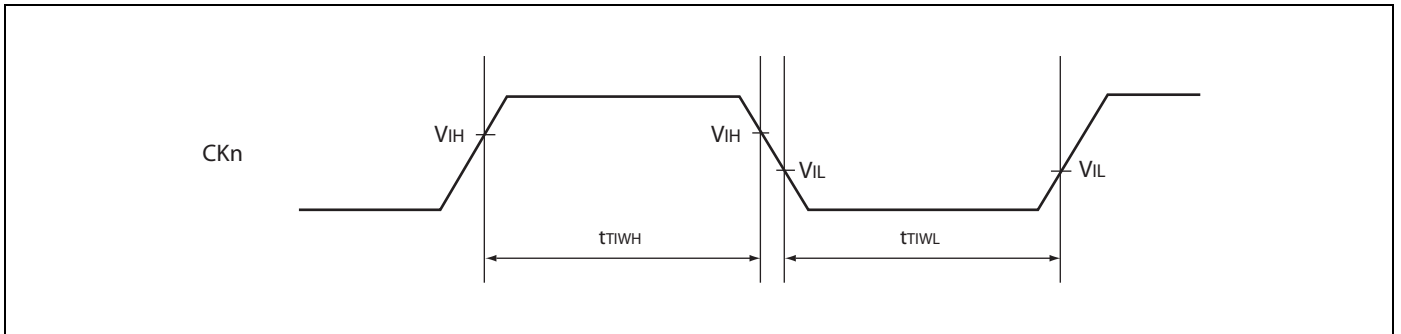

21.6.6 Trigger input timing

($V_{DD5} = 3.0\text{ V to } 5.5\text{ V}$, $V_{SS5} = AV_{SS5} = 0\text{ V}$, $T_A = -40\text{ }^\circ\text{C to } +125\text{ }^\circ\text{C}$)

Parameter	Symbol	Pin name	Condition	Value		Unit
				Min	Max	
Input capture input trigger	t_{INP}	ICUn	—	$5t_{CLKP}$	—	ns
A/D converter trigger	t_{ATGX}	ATGX	—	$5t_{CLKP}$	—	ns

Note : t_{CLKP} is the cycle time of the peripheral clock.

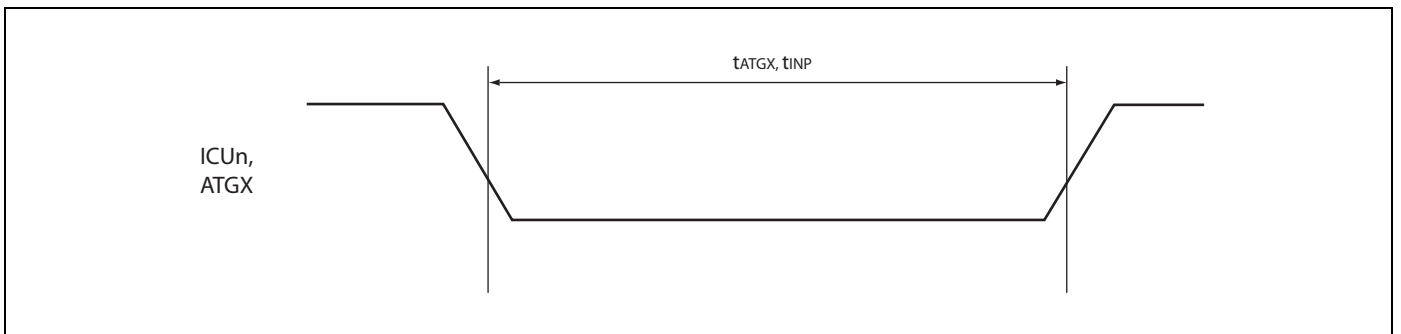

21.6.7 External Bus AC Timings at $V_{DD35} = 4.5$ to 5.5 V

- Conditions during AC measurements

All AC tests were measured under the following conditions:

- $I_{Odrive} = 5$ mA
- $V_{DD35} = 4.5$ V to 5.5 V, $I_{load} = 5$ mA
- $V_{SS5} = 0$ V
- $T_a = -40$ °C to $+125$ °C
- $C_l = 50$ pF
- $VOL = 0.2 \times V_{DD35}$
- $VOH = 0.8 \times V_{DD35}$
- EPILR = 0, PILR = 1 (Automotive Level = worst case)

Basic Timing

($V_{DD35} = 4.5$ V to 5.5 V, $V_{SS5} = AV_{SS5} = 0$ V, $T_A = -40$ °C to $+125$ °C)

Parameter	Symbol	Pin name	Value		Unit
			Min	Max	
SYSCLK	t_{CLCH}	SYSCLK	$1/2 \times t_{CLKT} - 4$	$1/2 \times t_{CLKT} + 2$	ns
	t_{CHCL}		$1/2 \times t_{CLKT} - 2$	$1/2 \times t_{CLKT} + 4$	ns
SYSCLK ↓ to CSXn delay time	t_{CLCSL}	SYSCLK CSXn	—	12	ns
	t_{CLCSH}		—	9	ns
SYSCLK ↑ to CSXn delay time (Addr → CS delay)	t_{CHCSL}		3	8	ns
SYSCLK ↓ to ASX delay time	t_{CLASL}	SYSCLK ASX	—	13	ns
	t_{CLASH}		—	12	ns
SYSCLK ↓ to Address valid delay time	t_{CLAV}	SYSCLK A23 to A0	—	13	ns

Note : t_{CLKT} is the cycle time of the external bus clock.

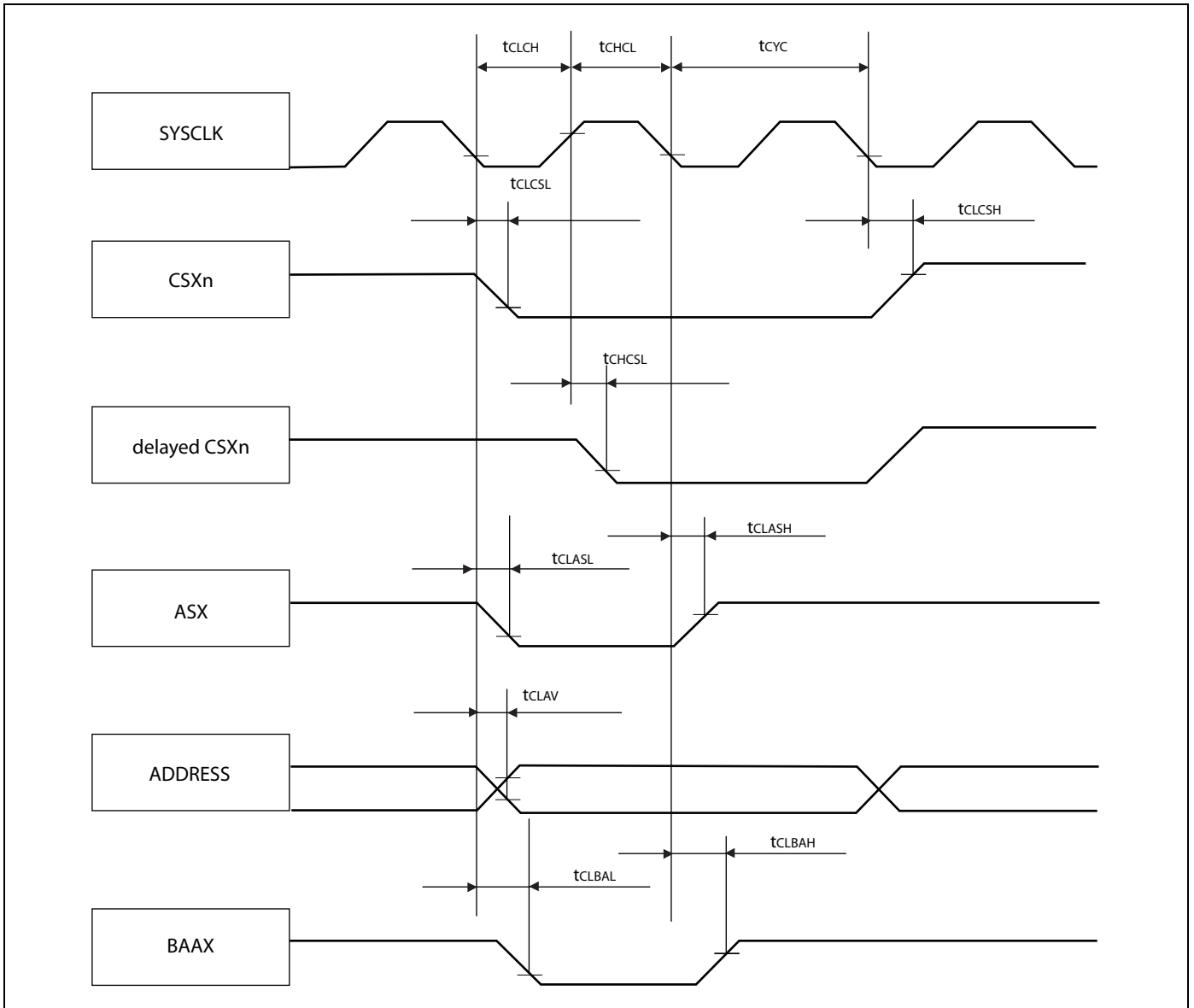

Synchronous/Asynchronous read access

($V_{DD35} = 4.5\text{ V to }5.5\text{ V}$, $V_{SS5} = AV_{SS5} = 0\text{ V}$, $T_A = -40\text{ }^\circ\text{C to }+125\text{ }^\circ\text{C}$)

Parameter	Symbol	Pin name	Value		Unit
			Min	Max	
SYSCLK \uparrow to RDX delay time	TCHRL	SYSCLK RDX	2	7	ns
	TCHRH		2	9	ns
Data valid to RDX \uparrow setup time	TDSRH	RDX D31 to D16	20	—	ns
RDX \uparrow to Data valid hold time	TRHDX	RDX D31 to D16	0	—	ns
SYSCLK \downarrow to WRXn (as byte enable) delay time	TCLWRL	SYSCLK WRXn	—	12	ns
	TCLWRH		3	—	ns
SYSCLK \downarrow to CSXn delay time	TCLCSL	SYSCLK CSXn	—	12	ns
	TCLCSH		—	9	ns

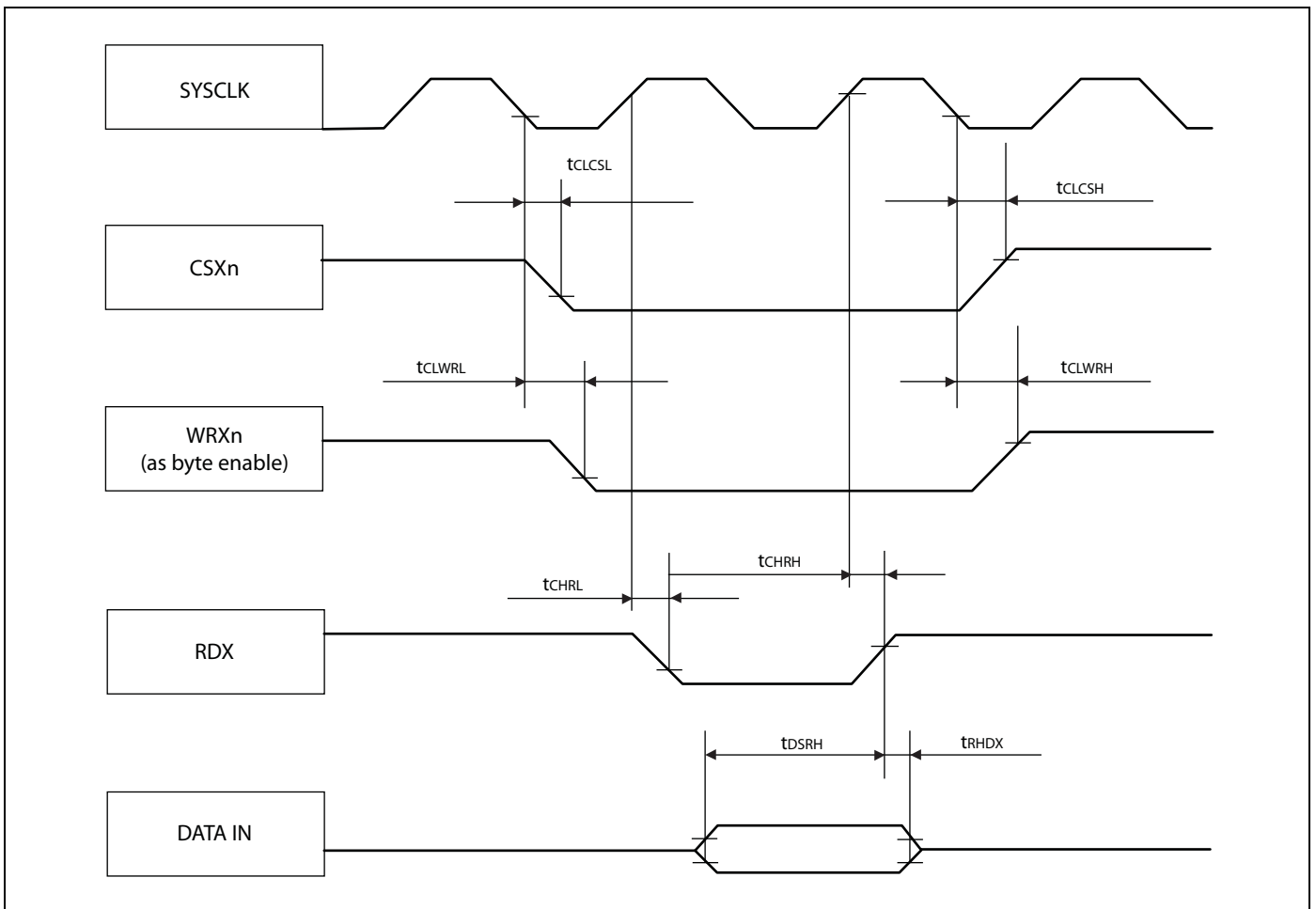

Synchronous write access - byte control type

($V_{DD35} = 4.5\text{ V to }5.5\text{ V}$, $V_{SS5} = AV_{SS5} = 0\text{ V}$, $T_A = -40\text{ }^\circ\text{C to }+125\text{ }^\circ\text{C}$)

Parameter	Symbol	Pin name	Value		Unit
			Min	Max	
SYSCLK ↓ to WEX delay time	TCLWL	SYSCLK	—	12	ns
	TCLWH	WEX	2	—	ns
Data valid to WEX ↓ setup time	TDSWL	WEX D31 to D16	- 2	—	ns
WEX ↑ to Data valid hold time	TWHDH	WEX D31 to D16	$t_{CLKT} - 9$	—	ns
SYSCLK ↓ to WRXn (as byte enable) delay time	TCLWRL	SYSCLK	—	12	ns
	TCLWRH	WRXn	3	—	ns
SYSCLK ↓ to CSXn delay time	TCLCSL	SYSCLK	—	12	ns
	TCLCSH	CSXn	—	9	ns

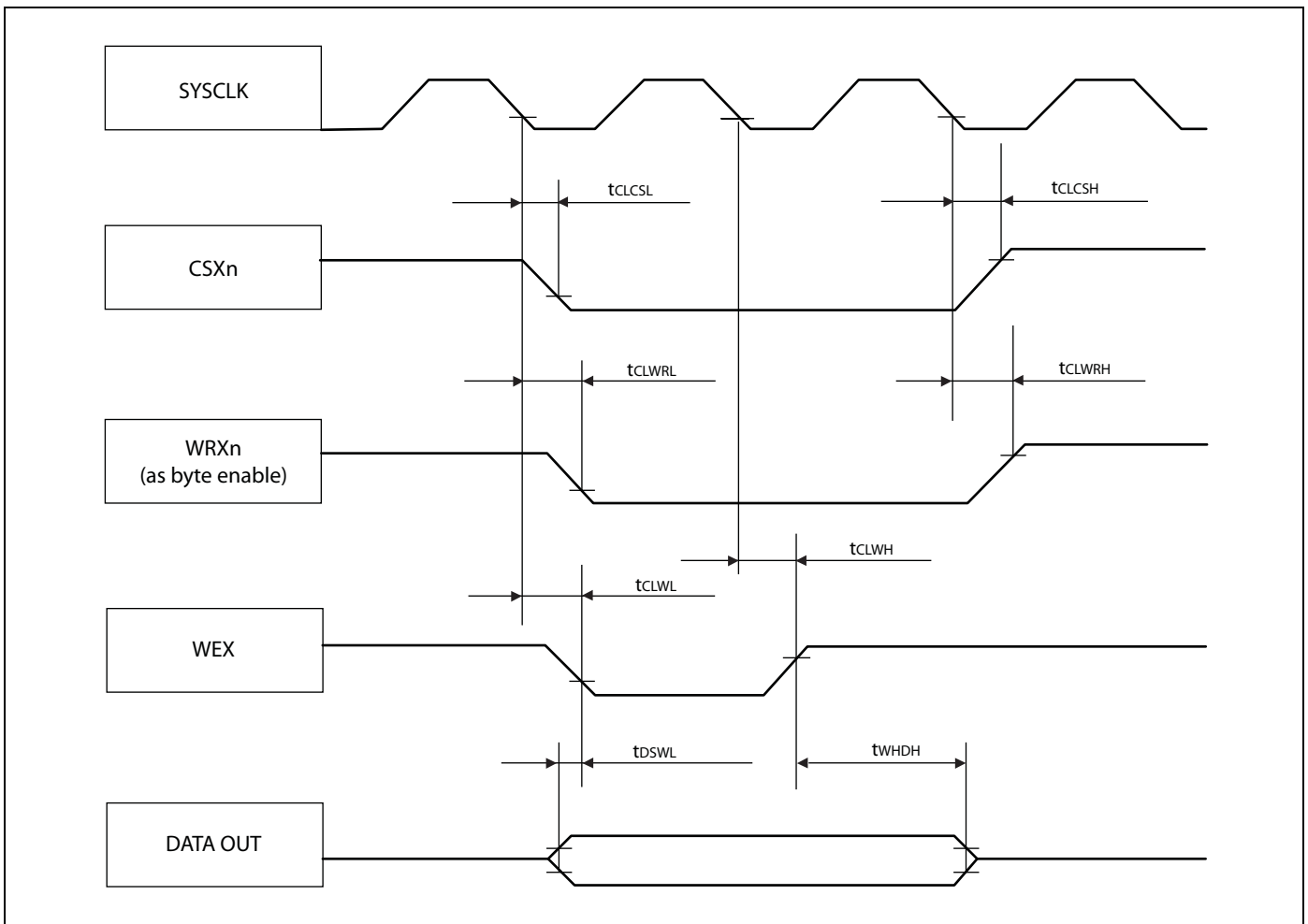

Synchronous write access - no byte control type

($V_{DD35} = 4.5\text{ V to }5.5\text{ V}$, $V_{SS5} = AV_{SS5} = 0\text{ V}$, $T_A = -40\text{ }^{\circ}\text{C to }+125\text{ }^{\circ}\text{C}$)

Parameter	Symbol	Pin name	Value		Unit
			Min	Max	
SYSCLK ↓ to WRXn delay time	TCLWRL	SYSCLK WRXn	—	12	ns
	TCLWRH		3	—	ns
Data valid to WRXn ↓ setup time	TDSWRL	WRXn D31 to D16	- 1	—	ns
WRXn ↑ to Data valid hold time	TWRHDH	WRXn D31 to D16	$t_{CLKT} - 9$	—	ns
SYSCLK ↓ to CSXn delay time	TCLCSL	SYSCLK CSXn	—	12	ns
	TCLCSH		—	9	ns

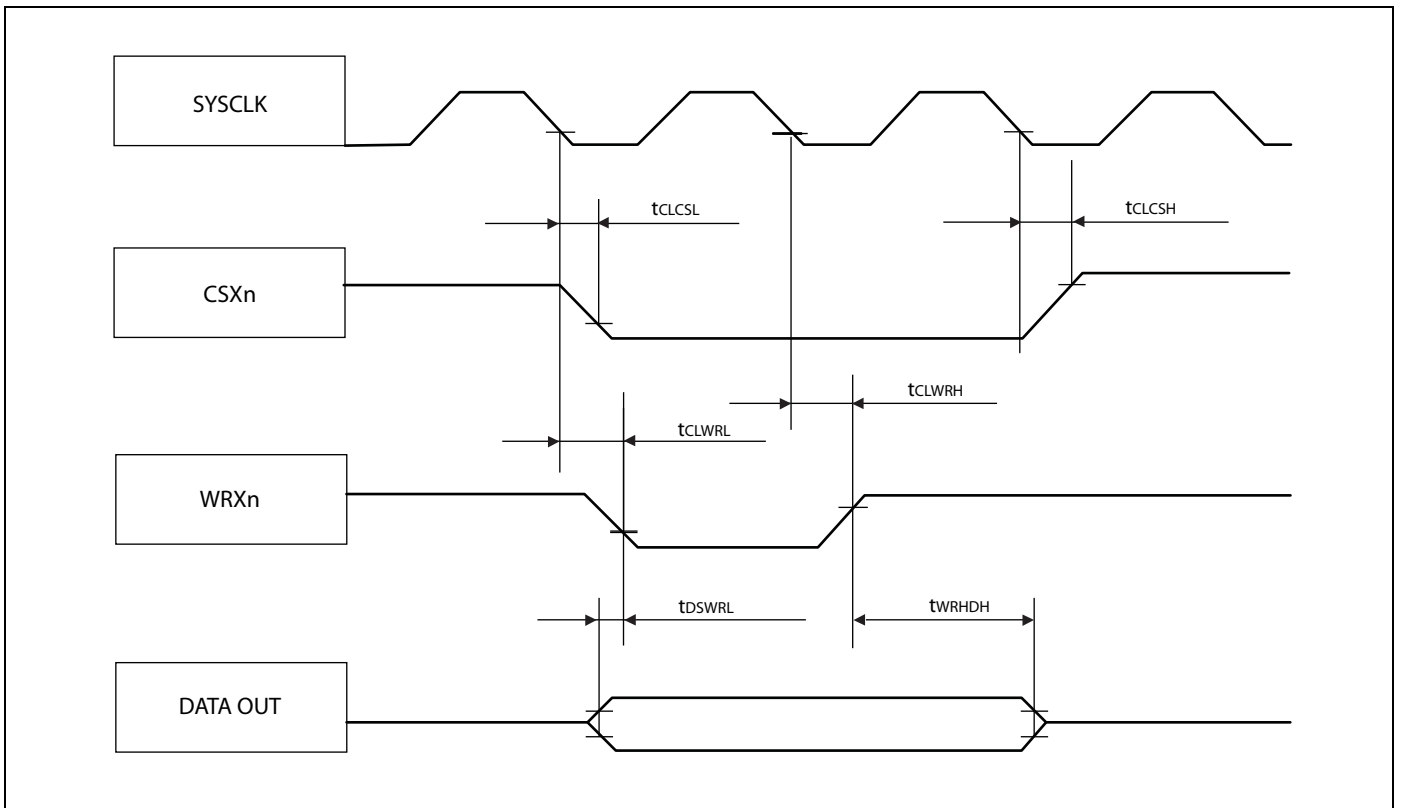

Asynchronous write access - byte control type

($V_{DD35} = 4.5\text{ V to }5.5\text{ V}$, $V_{SS5} = AV_{SS5} = 0\text{ V}$, $T_A = -40\text{ }^\circ\text{C to }+125\text{ }^\circ\text{C}$)

Parameter	Symbol	Pin name	Value		Unit
			Min	Max	
WEX ↓ to WEX ↑ pulse width	TWLWH	WEX	$t_{CLKT} - 8$	—	ns
Data valid to WEX ↓ setup time	TDSWL	WEX D31 to D16	$1/2 \times t_{CLKT} - 1$	—	ns
WEX ↑ to Data valid hold time	TWHDH	WEX D31 to D16	$1/2 \times t_{CLKT} - 9$	—	ns
WEX to WRXn delay time	TWRLWL	WEX WRXn	—	$1/2 \times t_{CLKT} + 1$	ns
	TWHWRH	WRXn	$1/2 \times t_{CLKT} - 0$	—	ns
WEX to CSXn delay time	TCLWL	WEX CSXn	—	$1/2 \times t_{CLKT} + 7$	ns
	TWHCH	CSXn	$1/2 \times t_{CLKT} - 1$	—	ns

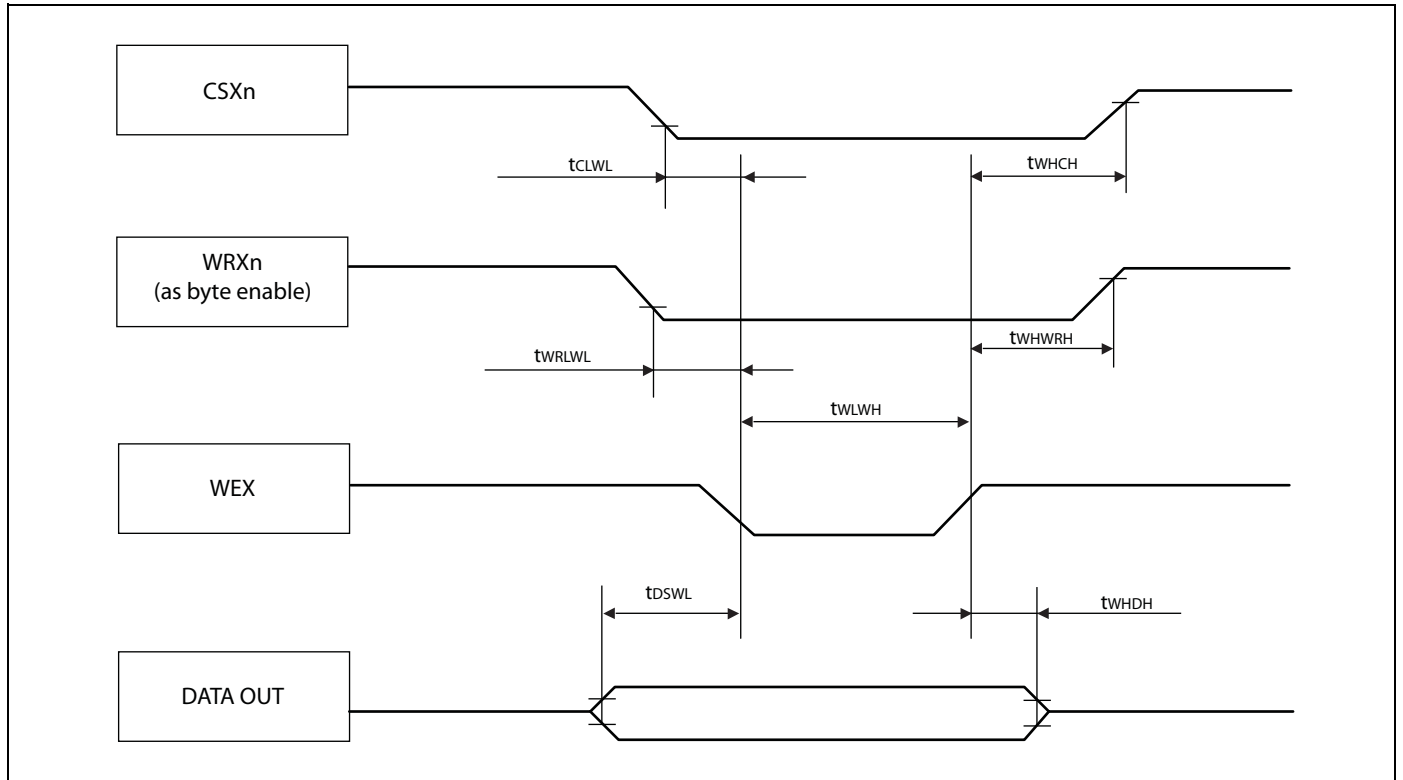

Asynchronous write access - no byte control type

($V_{DD35} = 4.5\text{ V to }5.5\text{ V}$, $V_{SS5} = AV_{SS5} = 0\text{ V}$, $T_A = -40\text{ }^\circ\text{C to }+125\text{ }^\circ\text{C}$)

Parameter	Symbol	Pin name	Value		Unit
			Min	Max	
WRXn ↓ to WRXn ↑ pulse width	TWRLWRH	WRXn	$t_{CLKT} - 7$	—	ns
Data valid to WRXn ↓ setup time	TDSWRL	WRXn D31 to D16	$1/2 \times t_{CLKT} - 1$	—	ns
WRXn ↑ to Data valid hold time	TWRHDH	WRXn D31 to D16	$1/2 \times t_{CLKT} - 9$	—	ns
WRXn to CSXn delay time	TCLWRL	WRXn CSXn	—	$1/2 \times t_{CLKT} + 7$	ns
	TWRHCH	WRXn CSXn	$1/2 \times t_{CLKT} - 1$	—	ns

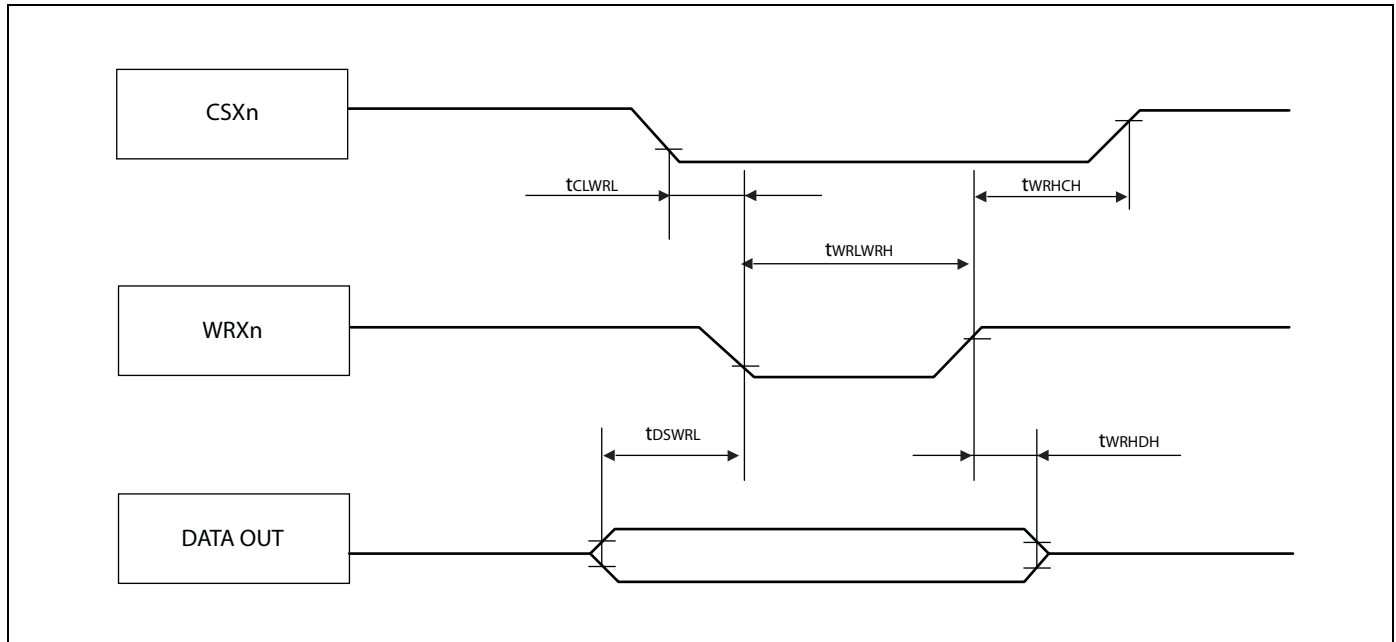

RDY waitcycle insertion
 $(V_{DD35} = 4.5 \text{ V to } 5.5 \text{ V}, V_{SS5} = AV_{SS5} = 0 \text{ V}, T_A = -40 \text{ }^\circ\text{C to } +125 \text{ }^\circ\text{C})$

Parameter	Symbol	Pin name	Value		Unit
			Min	Max	
RDY setup time	TRDYS	SYSCLK RDY	16	—	ns
RDY hold time	TRDYH	SYSCLK RDY	0	—	ns

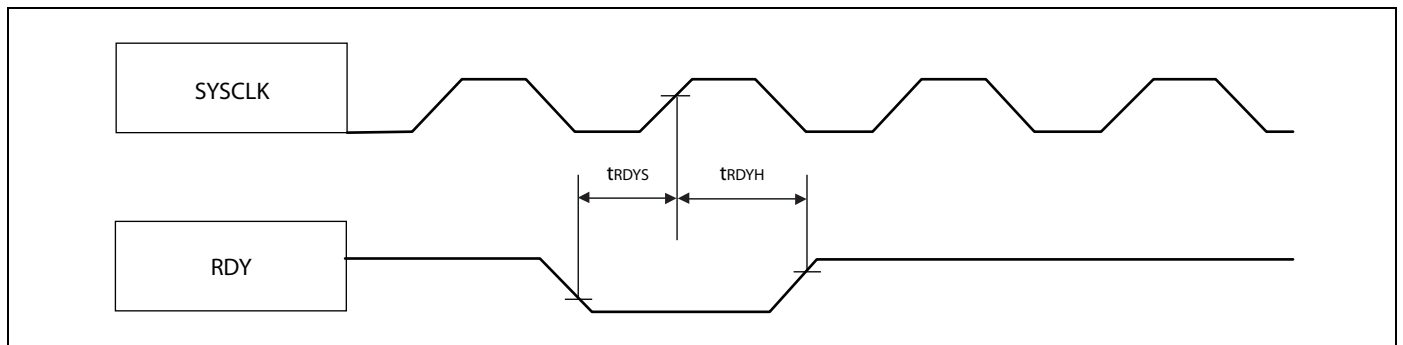

21.6.8 External Bus AC Timings at $V_{DD35} = 3.0$ to 4.5 V

- Conditions during AC measurements

All AC tests were measured under the following conditions:

- $I_{Odrive} = 5$ mA
- $V_{DD35} = 3.0$ V to 4.5 V, $I_{load} = 3$ mA
- $V_{SS5} = 0$ V
- $T_a = -40$ °C to $+125$ °C
- $C_l = 50$ pF
- $VOL = 0.2 \times V_{DD35}$
- $VOH = 0.8 \times V_{DD35}$
- EPILR = 0, PILR = 1 (Automotive Level = worst case)

Basic Timing

($V_{DD35} = 3.0$ V to 4.5 V, $V_{SS5} = AV_{SS5} = 0$ V, $T_A = -40$ °C to $+125$ °C)

Parameter	Symbol	Pin name	Value		Unit
			Min	Max	
SYSCLK	TCLCH	SYSCLK	$1/2 \times t_{CLKT} - 4$	$1/2 \times t_{CLKT} + 5$	ns
	TCHCL		$1/2 \times t_{CLKT} - 5$	$1/2 \times t_{CLKT} + 4$	ns
SYSCLK ↓ to CSXn delay time	TCLCSL	SYSCLK CSXn	—	8	ns
	TCLCSH		—	9	ns
SYSCLK ↑ to CSXn delay time (Addr → CS delay)	TCHCSL		1	8	ns
SYSCLK ↓ to ASX delay time	TCLASL	SYSCLK ASX	—	8	ns
	TCLASH		—	9	ns
SYSCLK ↓ to Address valid delay time	TCLAV	SYSCLK A23 to A0	—	12	ns

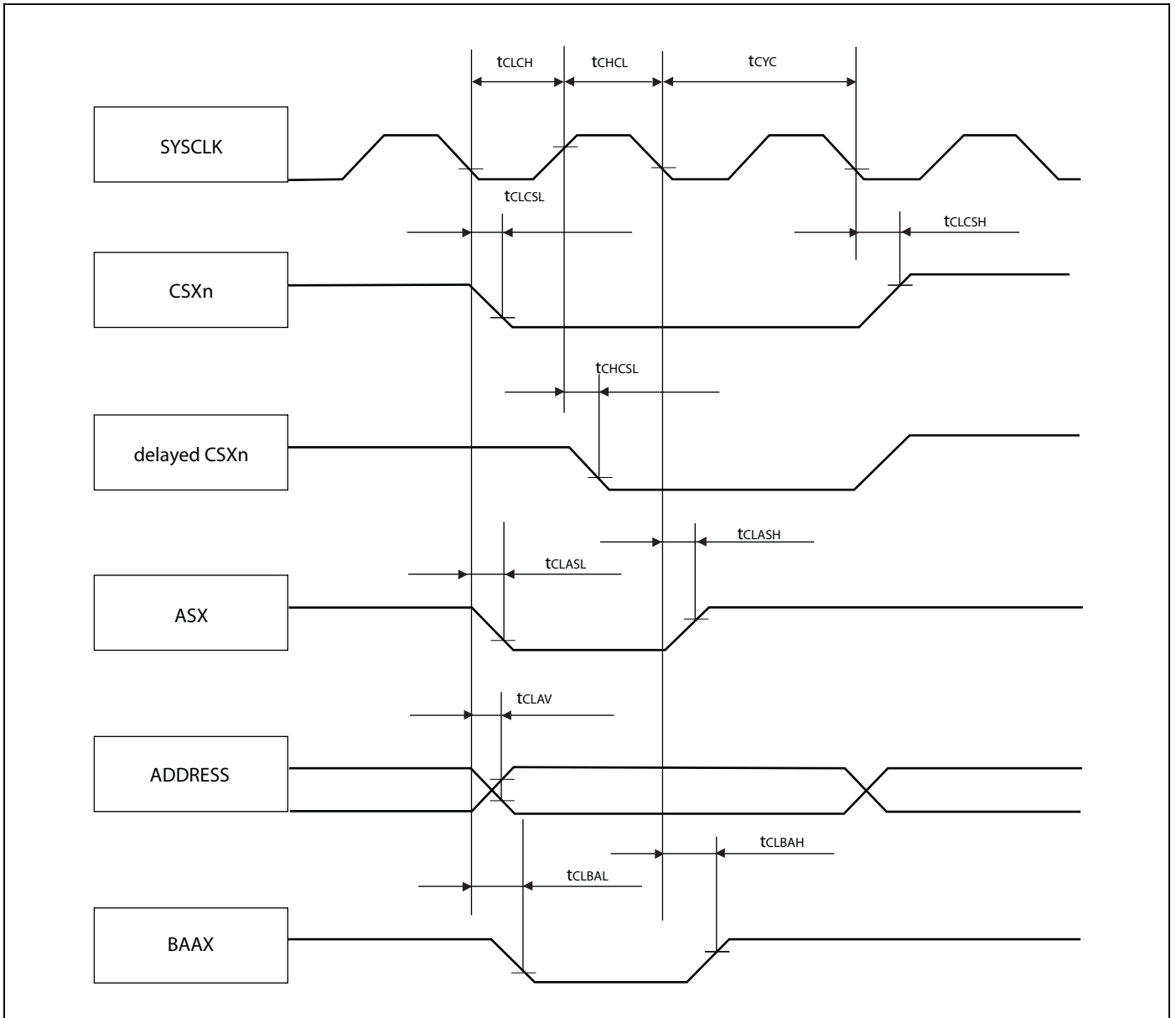

Synchronous/Asynchronous read access

($V_{DD35} = 3.0\text{ V to }4.5\text{ V}$, $V_{SS5} = AV_{SS5} = 0\text{ V}$, $T_A = -40\text{ }^\circ\text{C to }+125\text{ }^\circ\text{C}$)

Parameter	Symbol	Pin name	Value		Unit
			Min	Max	
SYSCLK \uparrow to RDX delay time	TCHRL	SYSCLK	1	8	ns
	TCHRH	RDX	2	8	ns
Data valid to RDX \uparrow setup time	TDSRH	RDX D31 to D16	26	—	ns
RDX \uparrow to Data valid hold time	TRHDX	RDX D31 to D16	0	—	ns
SYSCLK \downarrow to WRXn (as byte enable) delay time	TCLWRL	SYSCLK	—	9	ns
	TCLWRH	WRXn	3	—	ns
SYSCLK \downarrow to CSXn delay time	TCLCSL	SYSCLK	—	8	ns
	TCLCSH	CSXn	—	9	ns

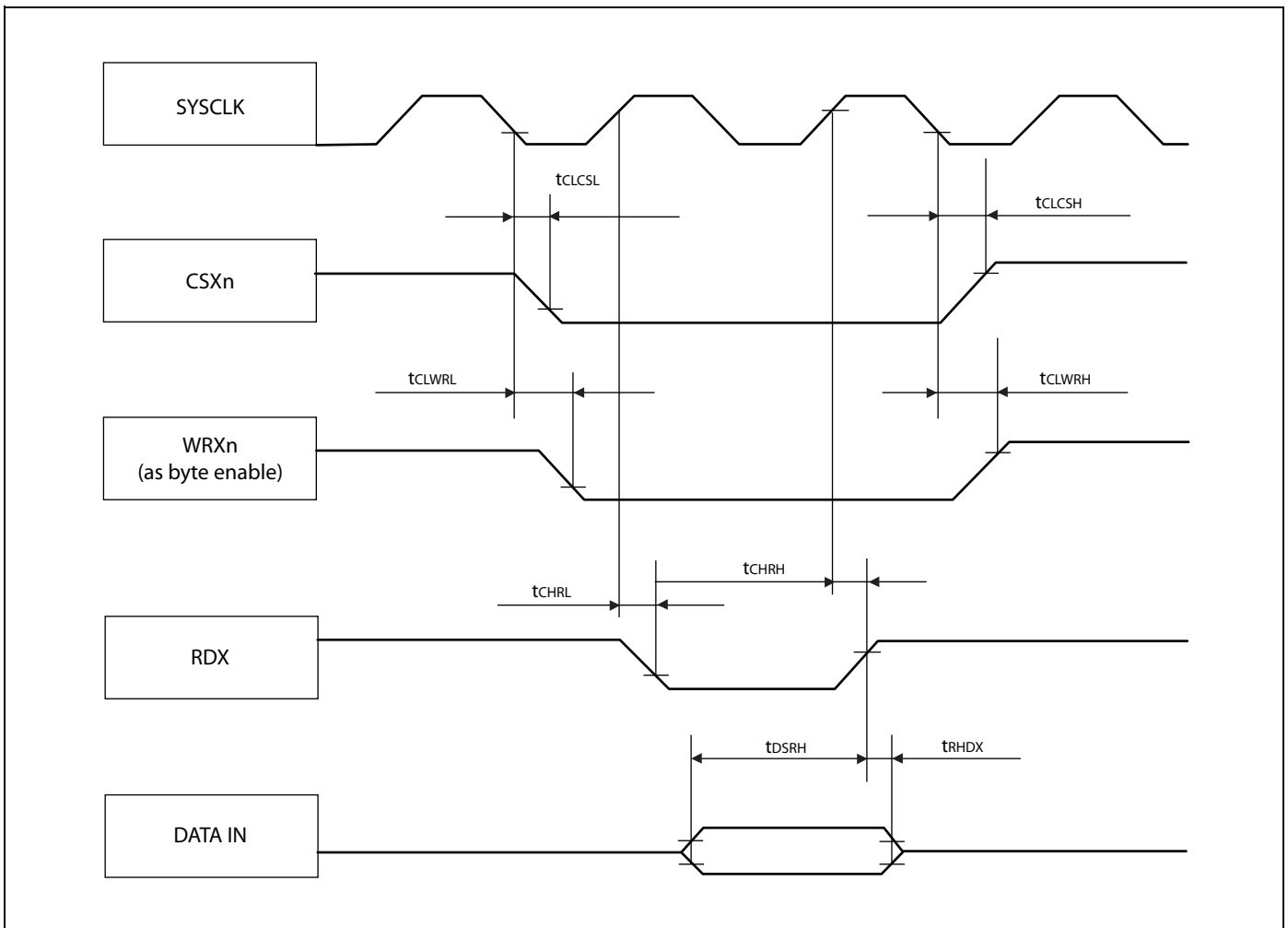

Synchronous write access - byte control type

($V_{DD35} = 3.0\text{ V to }4.5\text{ V}$, $V_{SS5} = AV_{SS5} = 0\text{ V}$, $T_A = -40\text{ }^\circ\text{C to }+125\text{ }^\circ\text{C}$)

Parameter	Symbol	Pin name	Value		Unit
			Min	Max	
SYSCLK ↓ to WEX delay time	TCLWL	SYSCLK WEX	—	9	ns
	TCLWH		3	—	ns
Data valid to WEX ↓ setup time	TDSWL	WEX D31 to D16	- 6	—	ns
WEX ↑ to Data valid hold time	TWHDH	WEX D31 to D16	$t_{CLKT} - 13$	—	ns
SYSCLK ↓ to WRXn (as byte enable) delay time	TCLWRL	SYSCLK WRXn	—	9	ns
	TCLWRH		4	—	ns
SYSCLK ↓ to CSXn delay time	TCLCSL	SYSCLK CSXn	—	8	ns
	TCLCSH		—	9	ns

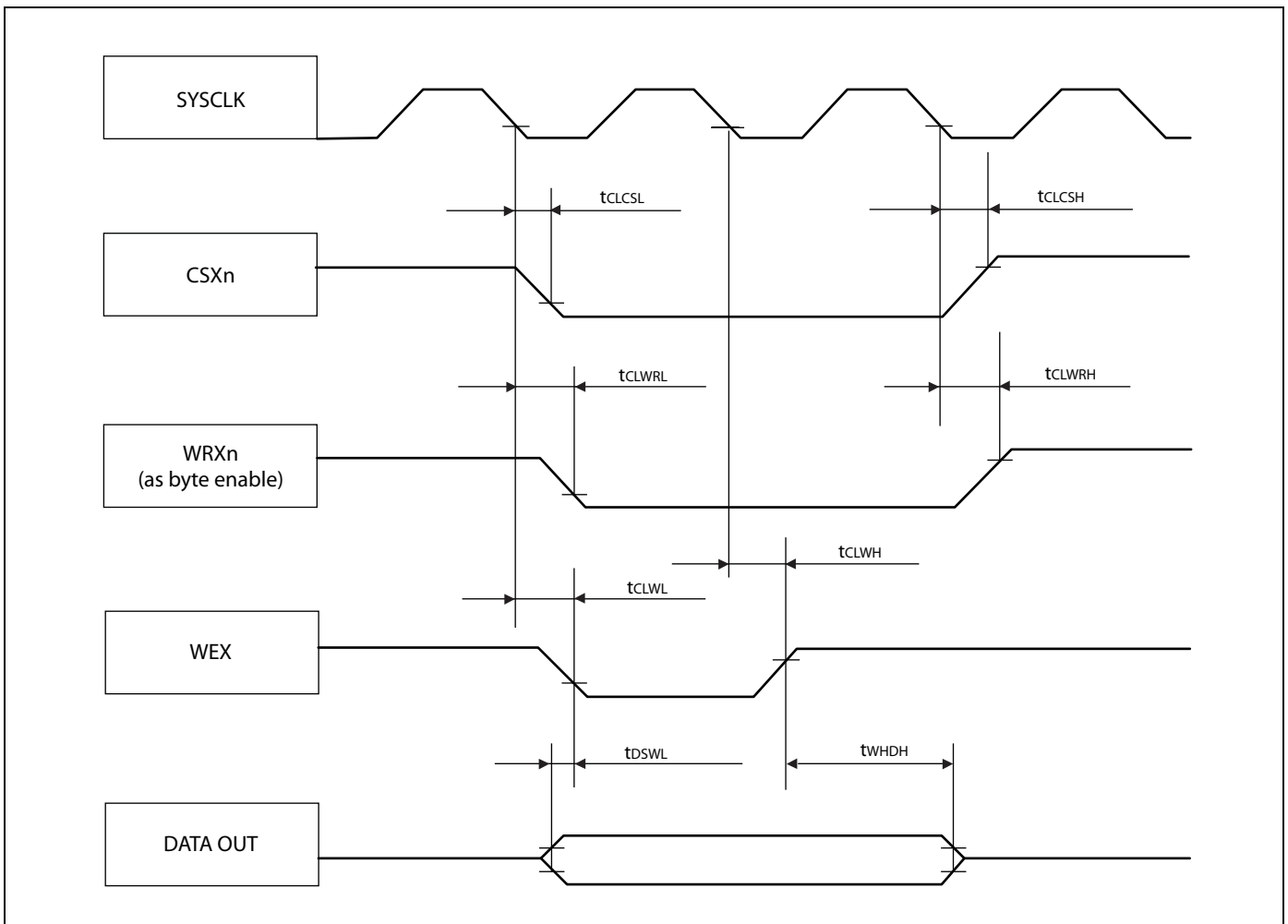

Synchronous write access - no byte control type

($V_{DD35} = 3.0\text{ V to }4.5\text{ V}$, $V_{SS5} = AV_{SS5} = 0\text{ V}$, $T_A = -40\text{ }^{\circ}\text{C to }+125\text{ }^{\circ}\text{C}$)

Parameter	Symbol	Pin name	Value		Unit
			Min	Max	
SYSCLK ↓ to WRXn delay time	TCLWRL	SYSCLK WRXn	—	9	ns
	TCLWRH		4	—	ns
Data valid to WRXn ↓ setup time	TDSWRL	WRXn D31 to D16	- 6	—	ns
WRXn ↑ to Data valid hold time	TWRHDH	WRXn D31 to D16	$t_{CLKT} - 15$	—	ns
SYSCLK ↓ to CSXn delay time	TCLCSL	SYSCLK CSXn	—	8	ns
	TCLCSH		—	9	ns

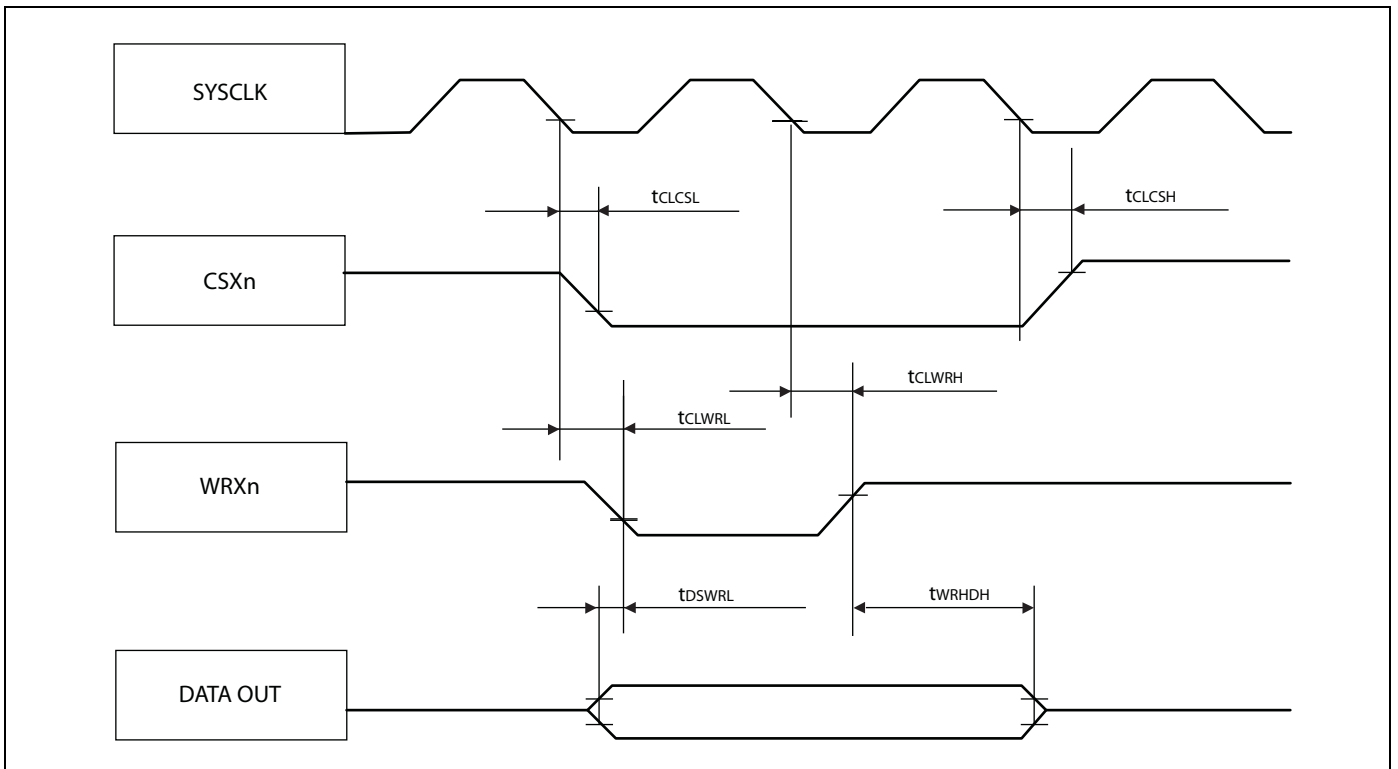

Asynchronous write access - byte control type

($V_{DD35} = 3.0\text{ V to }4.5\text{ V}$, $V_{SS5} = AV_{SS5} = 0\text{ V}$, $T_A = -40\text{ }^\circ\text{C to }+125\text{ }^\circ\text{C}$)

Parameter	Symbol	Pin name	Value		Unit
			Min	Max	
WEX ↓ to WEX ↑ pulse width	TWLWH	WEX	$t_{CLKT} - 4$	—	ns
Data valid to WEX ↓ setup time	TDSWL	WEX D31 to D16	$1/2 \times t_{CLKT} - 6$	—	ns
WEX ↑ to Data valid hold time	TWHDH	WEX D31 to D16	$1/2 \times t_{CLKT} - 13$	—	ns
WEX to WRXn delay time	TWRLWL	WEX WRXn	—	$1/2 \times t_{CLKT} + 1$	ns
	TWHWRH	WRXn	$1/2 \times t_{CLKT} - 1$	—	ns
WEX to CSXn delay time	TCLWL	WEX CSXn	—	$1/2 \times t_{CLKT} + 1$	ns
	TWHCH	CSXn	$1/2 \times t_{CLKT} - 0$	—	ns

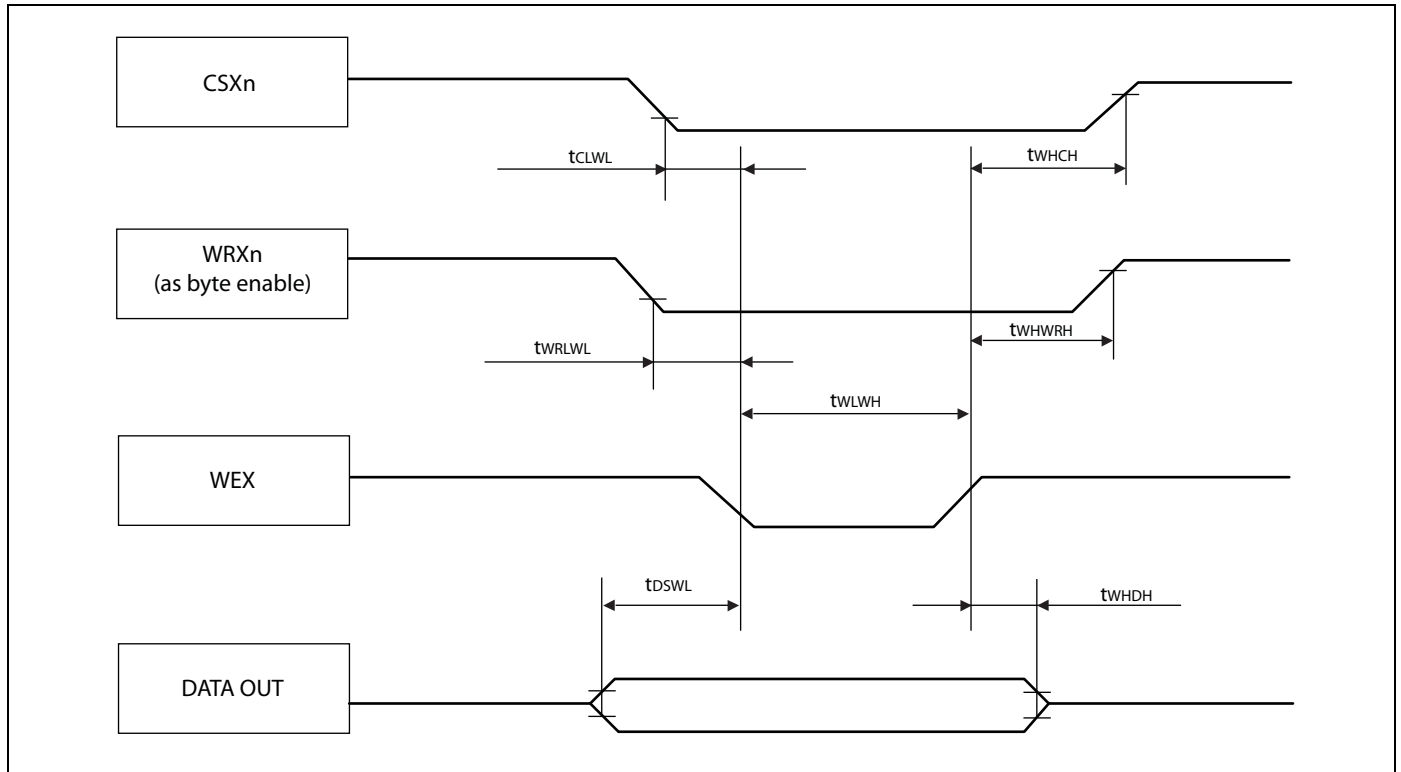

Asynchronous write access - no byte control type

($V_{DD35} = 3.0\text{ V to }4.5\text{ V}$, $V_{SS5} = AV_{SS5} = 0\text{ V}$, $T_A = -40\text{ }^\circ\text{C to }+125\text{ }^\circ\text{C}$)

Parameter	Symbol	Pin name	Value		Unit
			Min	Max	
WRXn ↓ to WRXn ↑ pulse width	TWRLWRH	WRXn	$t_{CLKT} - 2$	—	ns
Data valid to WRXn ↓ setup time	TDSWRL	WRXn D31 to D16	$1/2 \times t_{CLKT} - 6$	—	ns
WRXn ↑ to Data valid hold time	TWRHDH	WRXn D31 to D16	$1/2 \times t_{CLKT} - 14$	—	ns
WRXn to CSXn delay time	TCLWRL	WRXn	—	$1/2 \times t_{CLKT} + 1$	ns
	TWRHCH	CSXn	$1/2 \times t_{CLKT} - 0$	—	ns

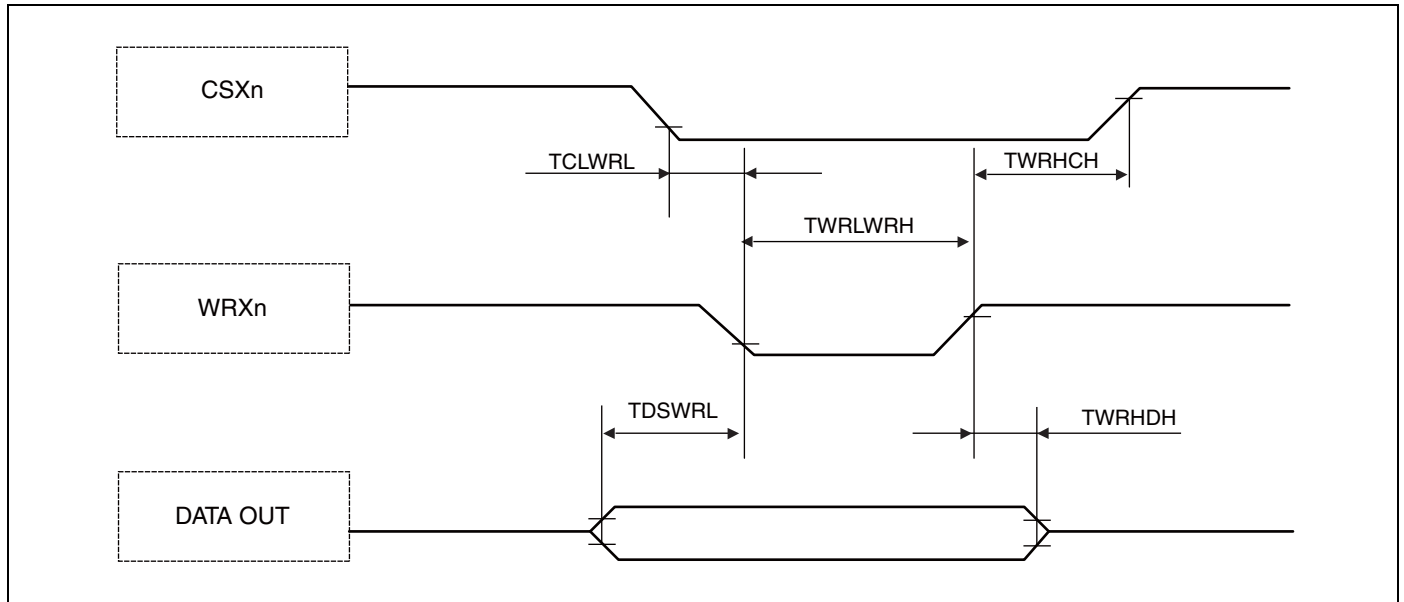

RDY waitcycle insertion

($V_{DD35} = 3.0\text{ V to }4.5\text{ V}$, $V_{SS5} = AV_{SS5} = 0\text{ V}$, $T_A = -40\text{ }^\circ\text{C to }+125\text{ }^\circ\text{C}$)

Parameter	Symbol	Pin name	Value		Unit
			Min	Max	
RDY setup time	TRDYS	SYSCLK RDY	21	—	ns
RDY hold time	TRDYH	SYSCLK RDY	0	—	ns

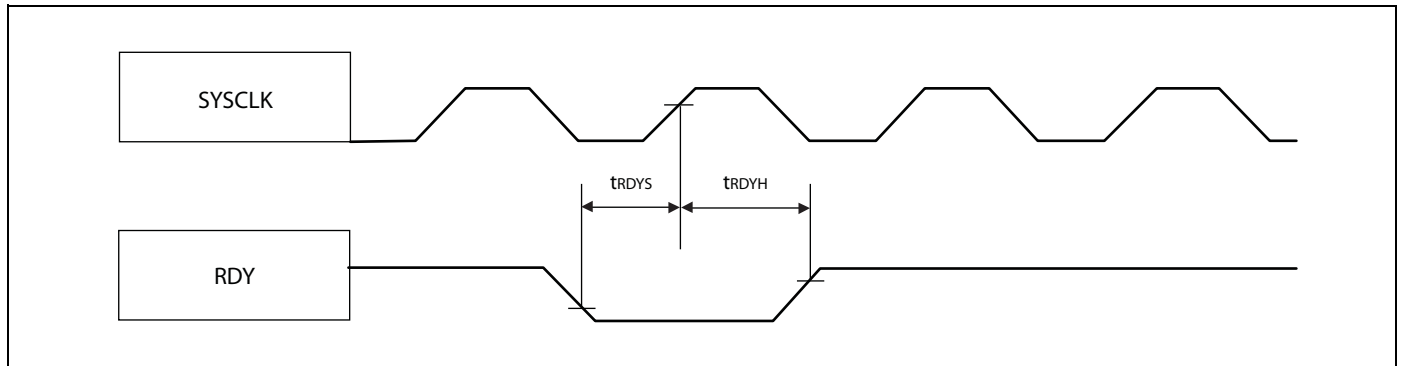

22. Ordering Information

Part number	Package	Remarks
CY91F465PAPMC-GS-UJE1	176-pin plastic LQFP (LQP176)	Lead-free package
CY91F465PAPMC-GS-UJE2	176-pin plastic LQFP (LQP176)	Lead-free package
CY91F467PAPMC-GS-UJE2	176-pin plastic LQFP (LQP176)	Lead-free package

23. Package Dimension

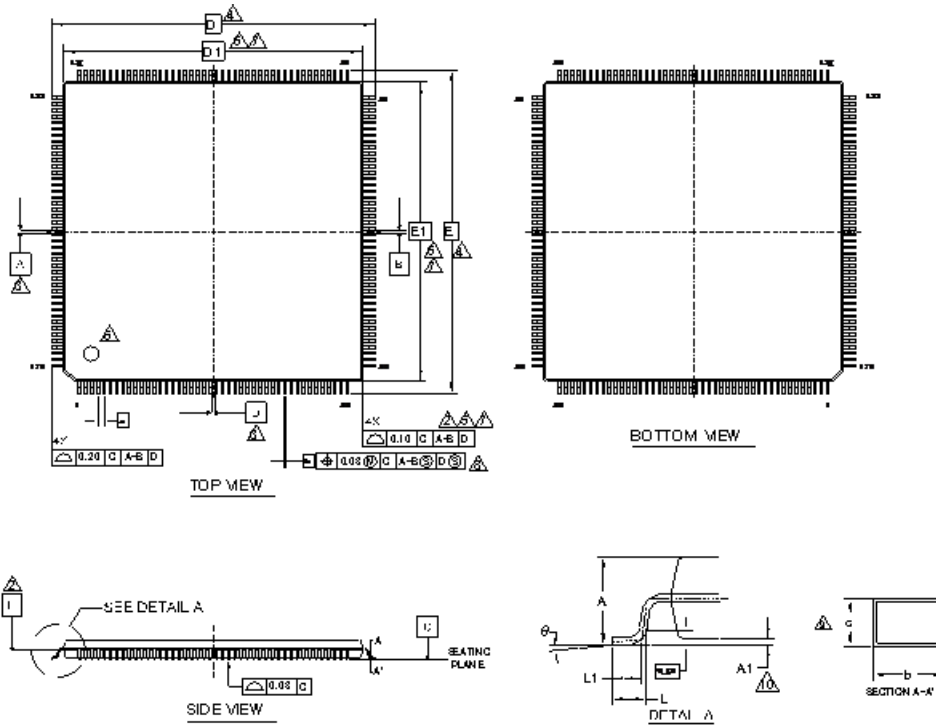

SYMBOL	DIMENSIONS		
	MIN.	NOM.	MAX.
A	—	—	1.70
A1	0.05	—	0.15
b	0.17	0.22	0.27
c	0.09	—	0.20
D	25.00 BSC		
D1	24.00 BSC		
e	0.30 BSC		
E	25.00 BSC		
E1	24.00 BSC		
L	0.45	0.60	0.75
L1	0.30	0.50	0.70
θ	0°	—	8°

NOTES

- ALL DIMENSIONS ARE IN MILLIMETERS.
- DATUM PLANE H IS LOCATED AT THE BOTTOM OF THE MOLD PARTING LINE GOING DENT WITH WHICH THE LEAD EXITS THE BODY.
- DATUMS A-B AND D TO BE DETERMINED AT DATUM PLANE H.
- TO BE DETERMINED AT SEATING PLANE C.
- DIMENSIONS D¹ AND E1 DO NOT INCLUDE MOLD PROTRUSION. ALLOWABLE PROTRUSION IS 0.25mm PER SIDE.
- DIMENSIONS D1 AND E1 INCLUDE MOLD MISMATCH AND ARE DETERMINED AT DATUM PLANE H.
- DETAILS OF PIN IDENTIFIER ARE OPTIONAL BUT MUST BE LOCATED WITHIN THE ZONE INDICATED.
- REGARDLESS OF THE RELATIVE SIZE OF THE UPPER AND LOWER BODY SECTIONS, DIMENSIONS D1 AND C1 ARE DETERMINED AT THE LARGEST FEATURE OF THE BODY EXCLUSIVE OF MOLD FLASH AND GATE BURRS, BUT INCLUDING ANY MISMATCH BETWEEN THE UPPER AND LOWER SECTIONS OF THE MOLD BODY.
- DIMENSION b DOES NOT INCLUDE DAMBAR PROTRUSION. THE DAMBAR PROTRUSION IS; SHALL NOT CAUSE THE LEAD WIDTH TO EXCEED A MAXIMUM BY MORE THAN 0.38mm. DAMBAR CANNOT BE LOCATED ON THE LOWER RADIUS OR THE LEAD FOOT.
- THESE DIMENSIONS APPLY TO THE FLAT SECTION OF THE LEAD WITHIN 0.15mm AND 0.25mm FROM THE LEAD TIP.
- A1 IS DEFINED AS THE DISTANCE FROM THE SEATING PLANE TO THE LOWEST POINT OF THE PACKAGE BODY.

002-15150 **

PACKAGE OUTLINE, 178 LEAD QFP
24.0X24.0X1.7 MM LQFP178 REV**

24. Revision History

Version	Date	Remark
2.0	2008-06-10	Initial version
2.1	2008-08-15	<p>Handling devices: Section Notes on PS Register changed for better understanding</p> <p>Interrupt Vector Table: corrected the footnotes</p> <p>FLASH: Added note about the flash operation mode switching, added section "Poweron Sequence in parallel programming mode"</p> <p>Absolute maximum ratings: Removed the note that analog input/output pins cannot accept +B signal input.</p> <p>DC Characteristics: Updated PullUp/Down resistors, updated the footnotes splitted ILV into external and internal LV detection</p> <p>AD Converter characteristics updated (complete section)</p>
2.2	2008-09-04	<p>Added MB91F467PA with Data Flash and 2 ADC macros:</p> <ul style="list-style-type: none"> - added chapter A/D Converter / New Features - added chapter A/D Converter / Range Comparator - added chapter Embedded Data Flash
2.3	2008-09-23	<p>A/D CONVERTER / NEW FEATURES (MB91F467PA): The ADC Channel Enable feature is only available on the non-relocated ADC channels 6-7.</p> <p>IO MAP: Added IOS register (addr. 0xC03) with note "always write 1 to IOS[1]"; Added bookmarks inside IO MAP; the IO MAP is common for MB91F465PA and MB91F467PA.</p> <p>EMBEDDED DATA FLASH (MB91F467PA): Added info about read operation during Command Sequencer write is active.</p>
3.0	2008-09-23	<p>Data Flash: Corrected text about Command Sequencer Mode (DFWC:WE bit); corrected TMG2,TMG1,TMG0=000 to max. 6.2MHz Corrected notes about CRC calculation (CLKB faster then RC clock)</p> <p>Embedded Program/Data Memory (Flash): Added section 7 "Notes About Flash Memory CRC Calculation" (CLKB must be faster then the RC clock)</p> <p>Pin Assignment: Corrected "SYSCLK7"</p> <p>Pin Description: Added X0/X1 pinning spec of F467PA Added Ta=125C characteristics</p>
3.1	not released yet	<p>Embedded Data Flash: Added 3 notes that "Dummy addresses for auto algorithm" cannot be used for toggle bit polling.</p> <p>DFCS register bit description: corrected INTEN into INTE,</p> <p>Data flash security: Added information about FSC_DISABLE.</p> <p>FLASH memory program/erase characteristics: Added 5.3 MB91F467PA DATA FLASH (erase / programming times)</p>

25. Major Changes

Spansion Publication Number: DS07-16615-2E

Page	Section	Change Results
31	Port Multiplexing	Corrected the text bubbles in Figure “3. Multiplex Pinout MB91F465PA”.
32		Corrected the text bubbles in Figure “4. Multiplex Pinout MB91F467PA”.
Rev *B		
-	Marketing Part Numbers changed from an MB prefix to a CY prefix.	
188 189	22. Ordering Information 23. Package Dimension	Package description modified to JEDEC description. (Before) FPT-176P-M07 (After) LQP176
188	22. Ordering Information	Revised the following parts number. Before) MB91F465PAPMC-GSE2 MB91F467PAPMC-GSE2 After) CY91F465PAPMC-GS-UJE2 CY91F467PAPMC-GS-UJE2 Added the following parts number. CY91F465PAPMC-GS-UJE1

NOTE: Please see “Document History” about later revised information.

Document History

Document Title: CY91460P Series FR60 32-bit Microcontroller Document Number: 002-04619				
Revision	ECN	Orig. of Change	Submission Date	Description of Change
**	—	AKIH	06/01/2010	Migrated to Cypress and assigned document number 002-04619. No change to document contents or format.
*A	5221463	AKIH	04/14/2016	Updated to Cypress format.
*B	6178926	GSHI	05/18/2016	Revised the following items: Marketing Part Numbers changed from an MB prefix to a CY prefix. 23.Package Dimension 22.Ordering Information For details, please see 25.Major Changes

Sales, Solutions, and Legal Information

Worldwide Sales and Design Support

Cypress maintains a worldwide network of offices, solution centers, manufacturer's representatives, and distributors. To find the office closest to you, visit us at [Cypress Locations](#).

Products

Arm® Cortex® Microcontrollers	cypress.com/arm
Automotive	cypress.com/automotive
Clocks & Buffers	cypress.com/clocks
Interface	cypress.com/interface
Internet of Things	cypress.com/iot
Memory	cypress.com/memory
Microcontrollers	cypress.com/mcu
PSoC	cypress.com/psoc
Power Management ICs	cypress.com/pmic
Touch Sensing	cypress.com/touch
USB Controllers	cypress.com/usb
Wireless Connectivity	cypress.com/wireless

PSoC® Solutions

[PSoC 1](#) | [PSoC 3](#) | [PSoC 4](#) | [PSoC 5LP](#) | [PSoC 6 MCU](#)

Cypress Developer Community

[Community](#) | [Projects](#) | [Video](#) | [Blogs](#) | [Training](#) | [Components](#)

Technical Support

cypress.com/support

© Cypress Semiconductor Corporation, 2009-2018. This document is the property of Cypress Semiconductor Corporation and its subsidiaries, including Spansion LLC ("Cypress"). This document, including any software or firmware included or referenced in this document ("Software"), is owned by Cypress under the intellectual property laws and treaties of the United States and other countries worldwide. Cypress reserves all rights under such laws and treaties and does not, except as specifically stated in this paragraph, grant any license under its patents, copyrights, trademarks, or other intellectual property rights. If the Software is not accompanied by a license agreement and you do not otherwise have a written agreement with Cypress governing the use of the Software, then Cypress hereby grants you a personal, non-exclusive, nontransferable license (without the right to sublicense) (1) under its copyright rights in the Software (a) for Software provided in source code form, to modify and reproduce the Software solely for use with Cypress hardware products, only internally within your organization, and (b) to distribute the Software in binary code form externally to end users (either directly or indirectly through resellers and distributors), solely for use on Cypress hardware product units, and (2) under those claims of Cypress's patents that are infringed by the Software (as provided by Cypress, unmodified) to make, use, distribute, and import the Software solely for use with Cypress hardware products. Any other use, reproduction, modification, translation, or compilation of the Software is prohibited.

TO THE EXTENT PERMITTED BY APPLICABLE LAW, CYPRESS MAKES NO WARRANTY OF ANY KIND, EXPRESS OR IMPLIED, WITH REGARD TO THIS DOCUMENT OR ANY SOFTWARE OR ACCOMPANYING HARDWARE, INCLUDING, BUT NOT LIMITED TO, THE IMPLIED WARRANTIES OF MERCHANTABILITY AND FITNESS FOR A PARTICULAR PURPOSE. No computing device can be absolutely secure. Therefore, despite security measures implemented in Cypress hardware or software products, Cypress does not assume any liability arising out of any security breach, such as unauthorized access to or use of a Cypress product. In addition, the products described in these materials may contain design defects or errors known as errata which may cause the product to deviate from published specifications. To the extent permitted by applicable law, Cypress reserves the right to make changes to this document without further notice. Cypress does not assume any liability arising out of the application or use of any product or circuit described in this document. Any information provided in this document, including any sample design information or programming code, is provided only for reference purposes. It is the responsibility of the user of this document to properly design, program, and test the functionality and safety of any application made of this information and any resulting product. Cypress products are not designed, intended, or authorized for use as critical components in systems designed or intended for the operation of weapons, weapons systems, nuclear installations, life-support devices or systems, other medical devices or systems (including resuscitation equipment and surgical implants), pollution control or hazardous substances management, or other uses where the failure of the device or system could cause personal injury, death, or property damage ("Unintended Uses"). A critical component is any component of a device or system whose failure to perform can be reasonably expected to cause the failure of the device or system, or to affect its safety or effectiveness. Cypress is not liable, in whole or in part, and you shall and hereby do release Cypress from any claim, damage, or other liability arising from or related to all Unintended Uses of Cypress products. You shall indemnify and hold Cypress harmless from and against all claims, costs, damages, and other liabilities, including claims for personal injury or death, arising from or related to any Unintended Uses of Cypress products.

Cypress, the Cypress logo, Spansion, the Spansion logo, and combinations thereof, WICED, PSoC, CapSense, EZ-USB, F-RAM, and Traveo are trademarks or registered trademarks of Cypress in the United States and other countries. For a more complete list of Cypress trademarks, visit cypress.com. Other names and brands may be claimed as property of their respective owners.

Looking for pricing, stock, or lifecycle information?

Click below to explore more details on WIN SOURCE:

 [View CY91F465PAPMC-GS-UJE1 on WIN SOURCE](#)

 [Infineon Technologies](#) Information

Optimize Your Supply Chain with WIN SOURCE Solutions

-  Global Sourcing Solution
-  Obsolete Management
-  Cost Control Management
-  Shortage Management
-  Alternative Solution
-  Excess Inventory Management