



**THE DATASHEET OF
CYPAS111A1-24LQXQT**



USB PD power adapter secondary side controller

General description

EZ-PD™ PAG1S is an integrated secondary-side synchronous flyback controller, synchronous rectifier (SR) controller, and charging port controller. EZ-PD™ PAG1S is targeted towards power adapters, it fits well into high-efficiency AC-DC flyback designs for USB Power Delivery, Qualcomm Quick Charge, and other standard charging protocols. EZ-PD™ PAG1S also supports USB Power Delivery (USB PD) programmable power supply (PPS) mode.

Applications

- USB PD 3.0 PPS power adapter
- Quick Charge 4.0 power adapter
- Power adapters supporting both USB PD and legacy charging

Features

- Integrates secondary-side regulation, synchronous rectifier (SR), and charging port controller
- Optimized efficiency across line and load range, meeting CoC Tier 2 and DoE level 6 requirements
- Supports quasi-resonant (QR) or critical conduction mode (CrCM), valley switching, discontinuous conduction mode (DCM), and burst mode for light load operations
- No load power consumption of < 30 mW with EZ-PD™ PAG1P designs
- Switching frequency range of 20 kHz to 150 kHz
- Supports feed-forward line sensing for faster transient line response
- Supports constant voltage (CV) and constant current (CC) modes of operation.
- Configurable overvoltage protection (OVP), undervoltage protection (UVP), overcurrent protection (OCP), short circuit protection (SCP), and over-temperature protection (OTP)
- USB PD 3.0 compliant with PPS (USB-IF certified, TID:1475)
- Supports USB PD 2.0, PD 3.0 with PPS, QC4+, QC 4.0, QC 3.0, QC 2.0, Samsung AFC, Apple charging, and BC v1.2 charging protocols
- Integrates low-side current sense amplifier (LSCSA), 2x VBUS discharge FETs, and a NFET gate driver to drive the load switch
- Protects against accidental VBUS to CC short; ESD protection on CC, VBUS, and DP/DM lines
- 24-QFN package with -40°C to +105°C extended industrial temperature range

Functional block diagram

Functional block diagram

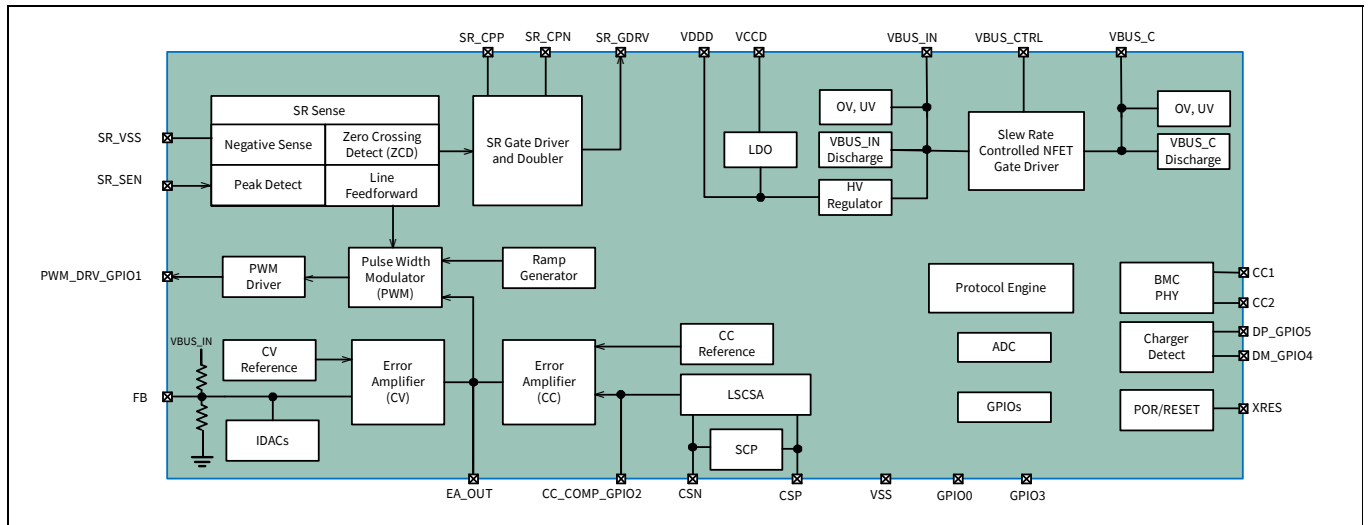

Table of contents

General description	1
Applications	1
Features	1
Functional block diagram	2
Table of contents	3
1 Pinout	4
1.1 Pin description	6
1.1.1 FB, EA_OUT, CC_COMP_GPIO2	8
1.1.2 PWM_DRV_GPIO1.....	9
1.1.3 CC1, CC2	10
1.1.4 DP_GPIO4, DM_GPIO5	10
1.1.5 VBUS_IN, VDDD, VCCD	11
1.1.6 VBUS_C, VBUS_CTRL	11
1.1.7 CSP, CSN	11
1.1.8 GPIO0, GPIO3.....	11
1.1.9 XRES.....	11
2 Application overview	12
2.1 USB Power Delivery power adapter with secondary side control.....	12
3 Functional description	13
3.1 Start-up behavior.....	13
3.2 Modes of operation	13
3.3 Fault protection	13
3.3.1 VBUS UVP and OVP	13
3.3.2 VBUS OCP and SCP	14
3.3.3 OTP	14
3.3.4 ESD protection	14
3.3.5 VBUS to CC short protection	14
3.4 Power modes	14
4 Electrical specifications	15
4.1 Absolute maximum ratings	15
4.2 Device-level specifications	16
4.3 Functional block specifications	17
4.4 I/O specifications	22
4.5 System resources specifications.....	23
5 Ordering information	24
5.1 Ordering code definitions.....	24
6 Packaging	25
7 Acronyms	27
8 Document conventions	29
8.1 Units of measure	29
Revision history	30

1 Pinout

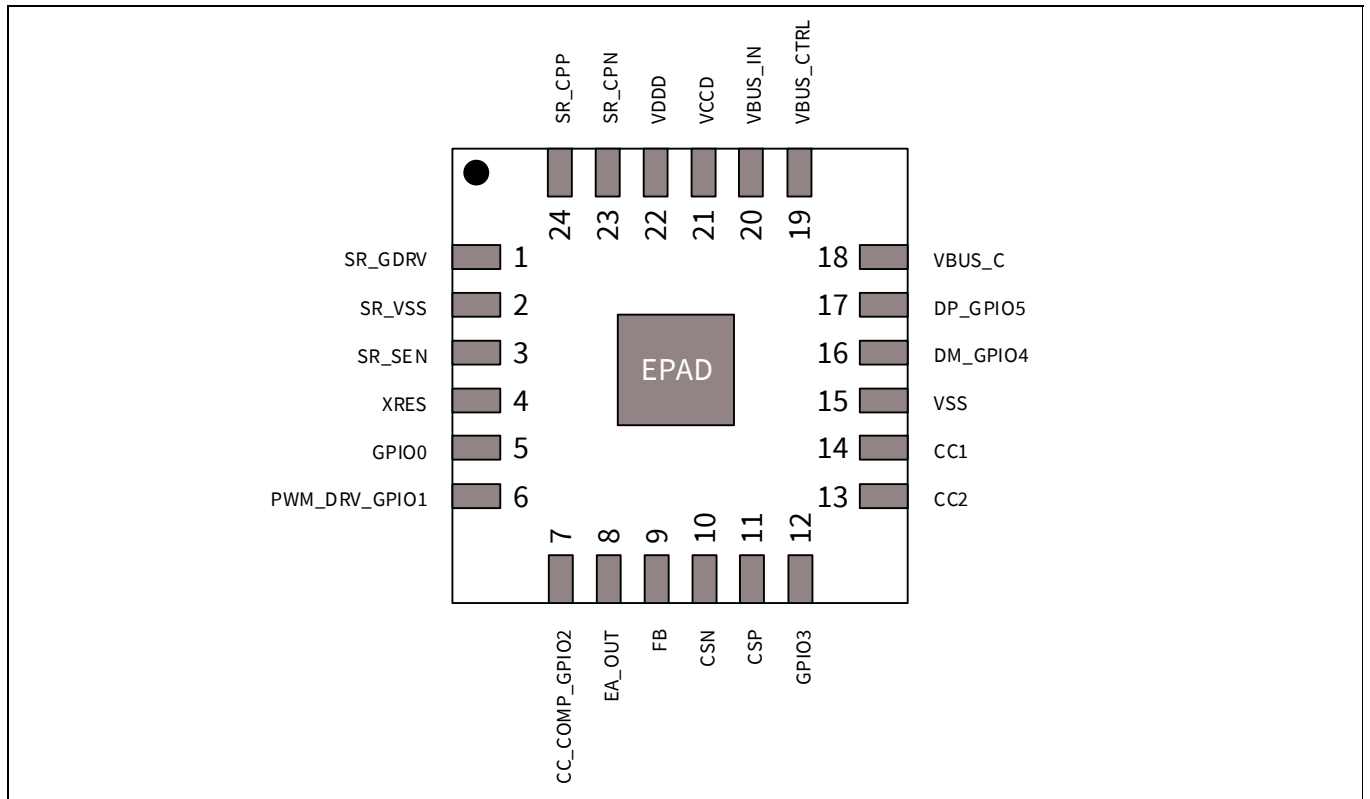

Figure 1 24-pin QFN pin map

Pinout

Table 1 EZ-PD™ PAG1S pin description

Pin number	Pin name	Description
1	SR_GDRV	Synchronous-rectifier NFET gate driver
2	SR_VSS	Synchronous-rectifier NFET ground terminal
3	SR_SEN	Synchronous-rectifier NFET drain terminal
4	XRES	External reset input
5	GPIO0	GPIO P0.0
6	PWM_DRV_GPIO1	Pulse transformer driver/GPIO P0.1
7	CC_COMP_GPIO2	Pin for constant current mode compensation capacitor/GPIO P0.2
8	EA_OUT	Error amplifier output
9	FB	Error amplifier feedback
10	CSN	Low-side current sense amplifier negative input
11	CSP	Low-side current sense amplifier positive input
12	GPIO3	GPIO P0.3
13	CC2	Power Delivery communication channel 2
14	CC1	Power Delivery communication channel 1
15	VSS	Ground
16	DM_GPIO4	USB D-/SWD_DATA/GPIO P0.4
17	DP_GPIO5	USB D+/SWD_CLK/GPIO P0.5
18	VBUS_C	USB Type-C VBUS monitor input
19	VBUS_CTRL	Load switch NFET gate control
20	VBUS_IN	Power source input
21	VCCD	1.8-V core voltage LDO output
22	VDDD	3.0 V–5.5 V internal LDO Output
23	SR_CPN	SR doubler capacitor negative pin
24	SR_CPP	SR doubler capacitor positive pin
25	EPAD	EPAD for ground

1.1 Pin description

SR_GDRV, SR_VSS, SR_SEN, SR_CPP, SR_CPN. EZ-PD™ PAG1S senses the voltage across the synchronous rectifier NFET and appropriately controls the gate driver to achieve optimum efficiency. The gate driver (SR_GDRV) can be driven to internal VDDD or twice of VDDD to achieve better RDS-On of the external NFET. The Gate Driver can be driven to twice of VDDD using an internal doubler circuit, with the doubler capacitor connected across SR_CPP and SR_CPN pins. The source terminal of the SR FET shall be connected to SR_VSS pin. Based on the operating conditions, the application firmware enables or disables the doubler as needed.

EZ-PD™ PAG1S supports synchronous rectification in QR/CrCM, valley switching, and DCM. The SR sense block supports negative sense detect, ZCD (Zero Crossing Detect), peak detect and feed-forward operation. The voltage at the drain node of the external NFET is sensed using a resistive divider. The internal resistor is 2 kΩ, the external resistor needs to be chosen such that the voltage at the SR_SEN pin does not exceed 21.5 V.

The external resistance on SR_SEN pin depends on turns ratio of power transformer. [Table 2](#) provides the values required for various values of turns ratio.

Table 2 External resistance on SR_SEN vs turns ratio

Primary : Secondary turns ratio	Rext (Ω)
4:1	10K
5:1	9K
6:1	8K
7:1	7K
8:1	6K
9:1	5K
10:1	4K

The fast-negative sense comparator can detect a minimum negative voltage of 100 mV to –200 mV on SR_SEN pin. Similarly, ZCD can detect a minimum threshold of –16 mV to 0 mV on the SR_SEN pin. The peak detect circuit can detect the SR_SEN pin going typically 75 mV lower than the peak. The feed-forward circuit extracts the input supply voltage from the SR_SEN node and proportionally modifies the analog PWM ramp generator output for faster transient line response. EZ-PD™ PAG1S offers a host of configurable options: minimum on time, minimum off time, minimum operating frequency, maximum operating frequency, and SR_SEN detect thresholds, among others. Refer [EZ-PD™ Configuration Utility](#) for more details on the configuration utility. See [Figure 2](#) and [Figure 3](#) for the waveforms representing the SR_GDRV functionality in QR/CrCM and DCM/valley switching.

Pinout

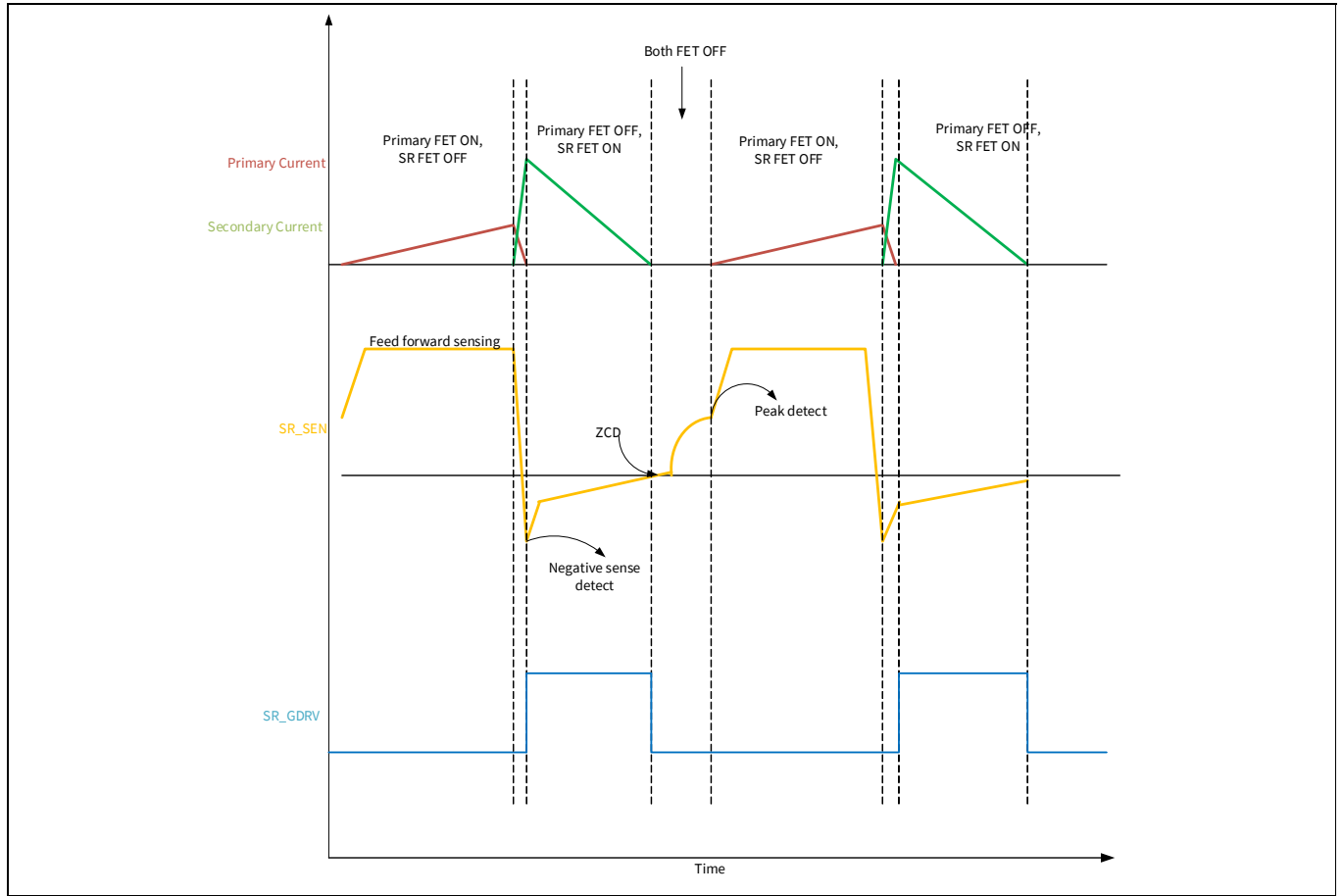

Figure 2 SR_SEN and SR_GDRV in QR/CrCM mode

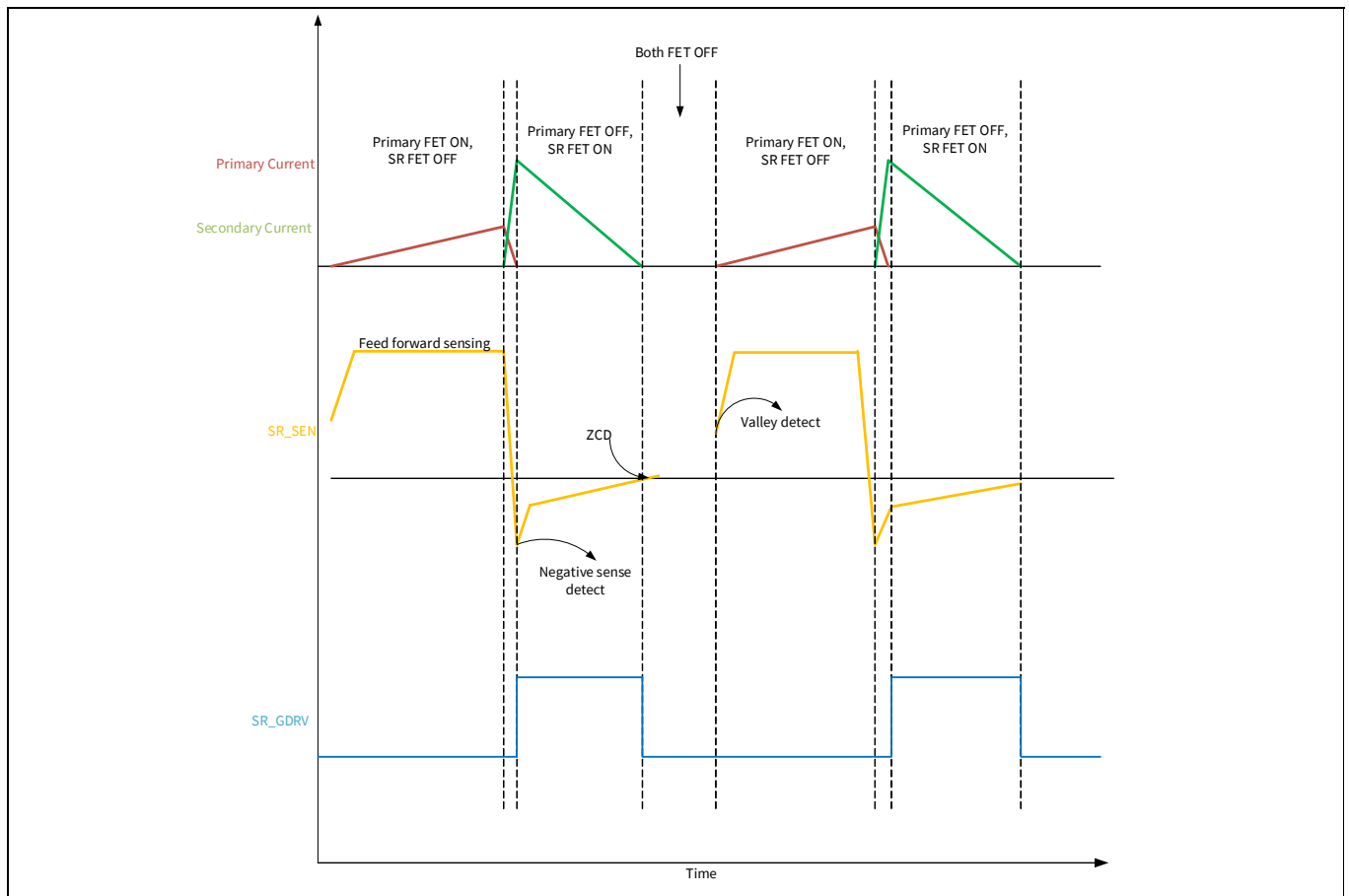

Figure 3 SR_SEN and SR_GDRV in DCM/valley switching mode

1.1.1 FB, EA_OUT, CC_COMP_GPIO2

EZ-PD™ PAG1S integrates two error amplifier blocks which handles secondary output sensing and regulation for constant voltage (CV) and constant current (CC) modes. This block is responsible for both constant voltage and constant current operations. The error-amplifier output feeds in to the internal analog PWM block. The negative input of the error amplifier is the feedback (FB) pin and the positive input is internal reference of 0.744 V. The FB pin has internal resistor divider of 200 kΩ and 35 kΩ, this divider sets a default voltage of 0.744 V at FB pin when VBUS_IN is at 5 V. Based on the desired VBUS_C output, the voltage at the FB pin will be varied using internal current source/sink IDACs. An external compensation network is required between FB pin and EA_OUT pin, as shown in [Figure 6](#).

Constant current operation makes use of an internal low-side current sense amplifier (LSCSA), the output of which feeds into an independent error amplifier as shown in [Figure 1](#). The reference to Constant current error-amplifier is programmable between 0.4 V to 2.1 V. Constant current mode regulation requires an external compensation network between CC_COMP_GPIO2 and EA_OUT as shown in [Figure 6](#). EZ-PD™ PAG1S error amplifier can ensure constant voltage regulation from 3.3 V to 21.5 V range and constant current regulation from 1 A to 3 A as required by the USB PD PPS specification.

1.1.2 PWM_DRV_GPIO1

EZ-PD™ PAG1S supports an analog PWM generator, which modulates the pulse width of the primary side FET in voltage mode control. It generates a programmable ramp which is compared against the output of the error amplifier to determine the PWM pulse width. The ramp is generated by sourcing current into an internal capacitor, the source current is a programmable combination of a certain fixed current and feed forward current. The PWM signal is transferred from the secondary side to the primary side through an external pulse transformer. EZ-PD™ PAG1S also integrates a pulse transformer driver with VDDD/Ground based output. The output of the pulse transformer driver is brought out onto the PWM_DRV_GPIO1 pin.

See [Figure 4](#) and [Figure 5](#) for the waveforms representing PWM_DRV functionality in QR/CrCM and DCM/valley switching.

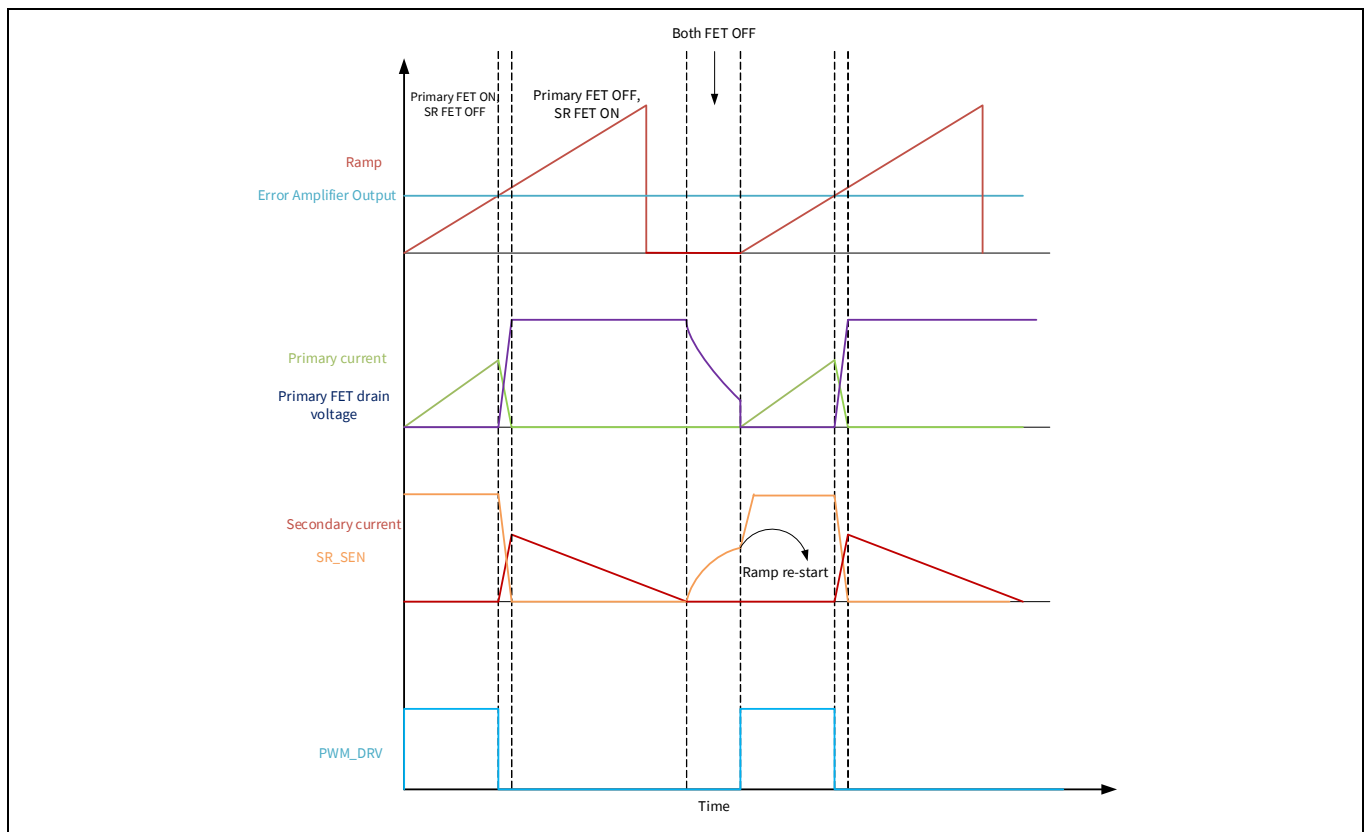

Figure 4 PWM_DRV in QR/CrCM mode

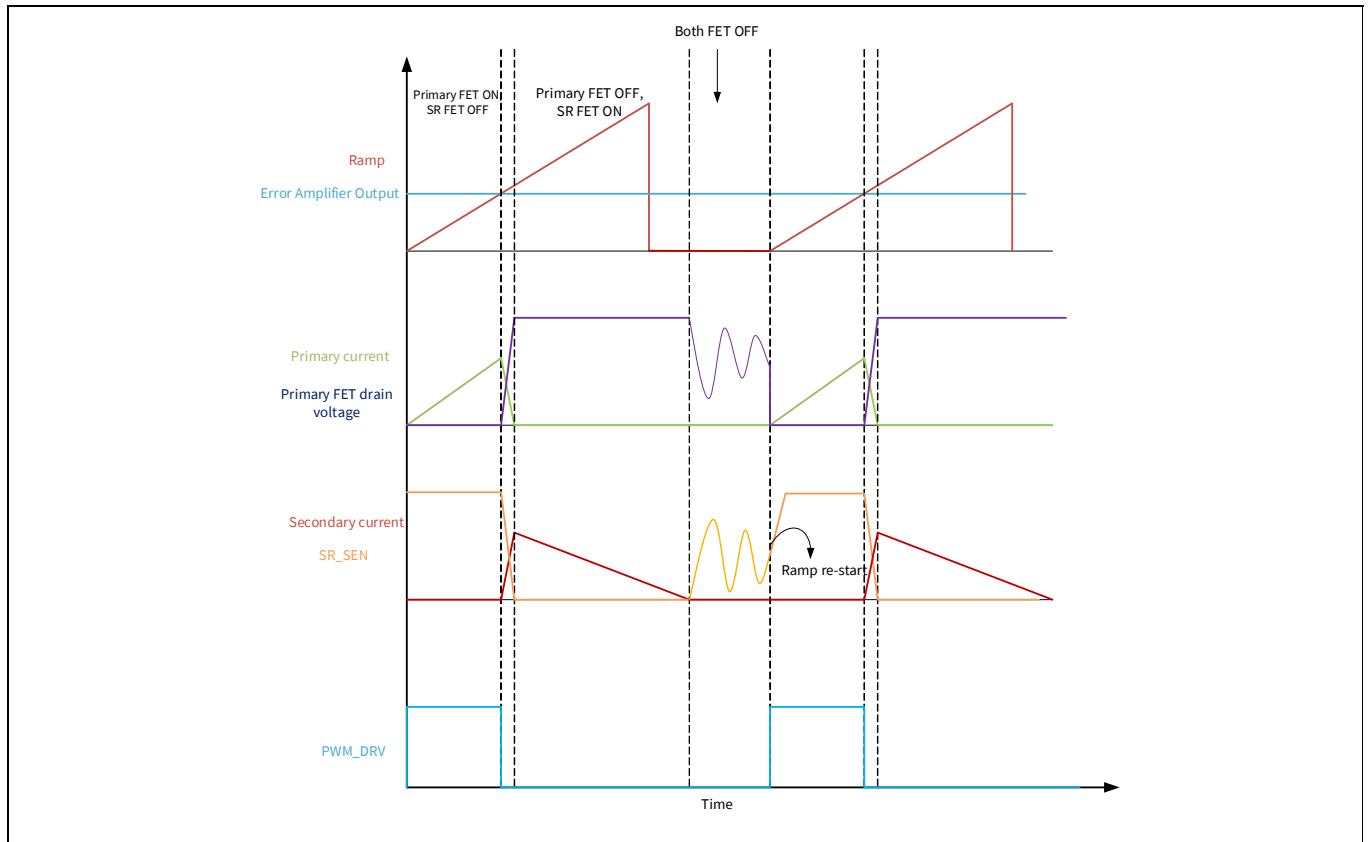

Figure 5 PWM_DRV in DCM/valley switching mode

1.1.3 CC1, CC2

CC1 and CC2 are the communication channels for USB PD protocol. EZ-PD™ PAG1S integrates a USB PD transceiver consisting of a transmitter and receiver that communicate Biphase Mark Code (BMC) encoded data over the Configuration Channel (CC) channels as per the USB PD standard. All communication is half-duplex. The physical layer implements collision avoidance to minimize communication errors on the channel. This block includes all termination resistors (R_p) and their switches as required by the USB PD specification. An external 390-pF capacitor is required on both the CC1 and CC2 pins.

1.1.4 DP_GPIO4, DM_GPIO5

The DP and DM lines are the standard USB D+ and D- lines. EZ-PD™ PAG1S integrates a charge detect block, which handles legacy charging protocols such as BC 1.2, Quick Charge, Apple charging, and Samsung AFC. This block integrates all the terminations required for these charging protocols and no external components are required. When legacy charging is not required in the system, the same DP and DM lines can be re-used as standard GPIOs.

1.1.5 VBUS_IN, VDDD, VCCD

EZ-PD™ PAG1S integrates a high-voltage regulator, which is powered from the VBUS_IN rail, the output of the regulator powers the VDDD rail. The input to the regulator can range from 3.3 V minimum to 21.5 V maximum. When the input is between 5.5 V and 21.5 V, the typical output of the regulator is 5 V. For inputs from 3.3 V to 5.5 V, the regulator output is VBUS_IN – 300 mV.

This regulator can drive a maximum load current of 50 mA, which includes the chip current consumption. This regulator is not expected to drive any external loads or ICs. EZ-PD™ PAG1S also has an internal configurable discharge path for the VBUS_IN rail, which is used to discharge the VBUS rail during negative voltage transitions. Through firmware settings, the internal discharge resistor can be set between 31.25 Ω to 2000 Ω.

The regulated supply VDDD, is either used to directly power some internal analog blocks or further regulated down to 1.8 V VCCD, which powers majority of the core. VDDD and VCCD is brought out on to pins to connect external capacitors for regulator stability and these are not meant to be used as power supplies.

1.1.6 VBUS_C, VBUS_CTRL

VBUS_C is used to monitor the voltage at the Type-C connector. VBUS_C has an internal configurable discharge path, which is used to discharge the VBUS_C rail during negative voltage transitions. Through firmware settings, the internal discharge resistor can be set between 31.25 Ω to 2000 Ω.

The load switch is between VBUS_IN and VBUS_C. EZ-PD™ PAG1S integrates a NFET gate driver to control this load switch. VBUS_CTRL is the output of this gate driver. To turn off the external NFET, the gate driver drives low. To turn on the external NFET, it drives the gate to VBUS_IN + 8 V. In addition, there is a clamp circuit to limit the gate to VBUS_IN + 8 V. There is an optional slow turn-on feature which is meant to avoid sudden in-rush current. For a typical gate capacitance of 3nF, a slow turn-on time of 2 ms to 10 ms is configurable using firmware.

1.1.7 CSP, CSN

EZ-PD™ PAG1S integrates a LSCSA to monitor the load current. CSP is the positive input pin for the LSCSA and CSN is the negative input. LSCSA offers wide gain options ranging from 5 to 150. Suggested Rsense for LSCSA is 5 mΩ. LSCSA has an active offset cancellation mechanism to improve accuracy.

1.1.8 GPIO0, GPIO3

EZ-PD™ PAG1S has six GPIOs, out of which two are dedicated GPIOs and the rest are multiplexed with other functionalities. These GPIOs support multiple drive modes and configurable threshold options. During power-on and reset, the I/O pins (except GPIO1) are forced to the tristate so as not to crowbar any inputs and/or cause excess turn-on current. PWM_DRV_GPIO1 is driven to zero at power-up to avoid spurious start of primary IC.

1.1.9 XRES

The XRES pin can be used to initiate a reset, this pin is internally pulled high and needs to be pulled low externally to trigger reset.

2 Application overview

2.1 USB Power Delivery power adapter with secondary side control

Figure 6 shows a power adapter application diagram implementing a secondary side controlled synchronous flyback system. In this system, EZ-PD™ PAG1S modulates the pulse width of the primary MOSFET in voltage mode control. EZ-PD™ PAG1S engages the error amplifier and a programmable ramp generator to determine the pulse width of the PWM. This PWM signal is transferred from the secondary to the primary side through a pulse transformer. The primary controller can be any standard primary start-up controller and in **Figure 6**, EZ-PD™ PAG1P is used as the primary controller with EZ-PD™ PAG1S. In this topology, EZ-PD™ PAG1S integrates three key features: secondary side control, synchronous rectification, and charging port controller.

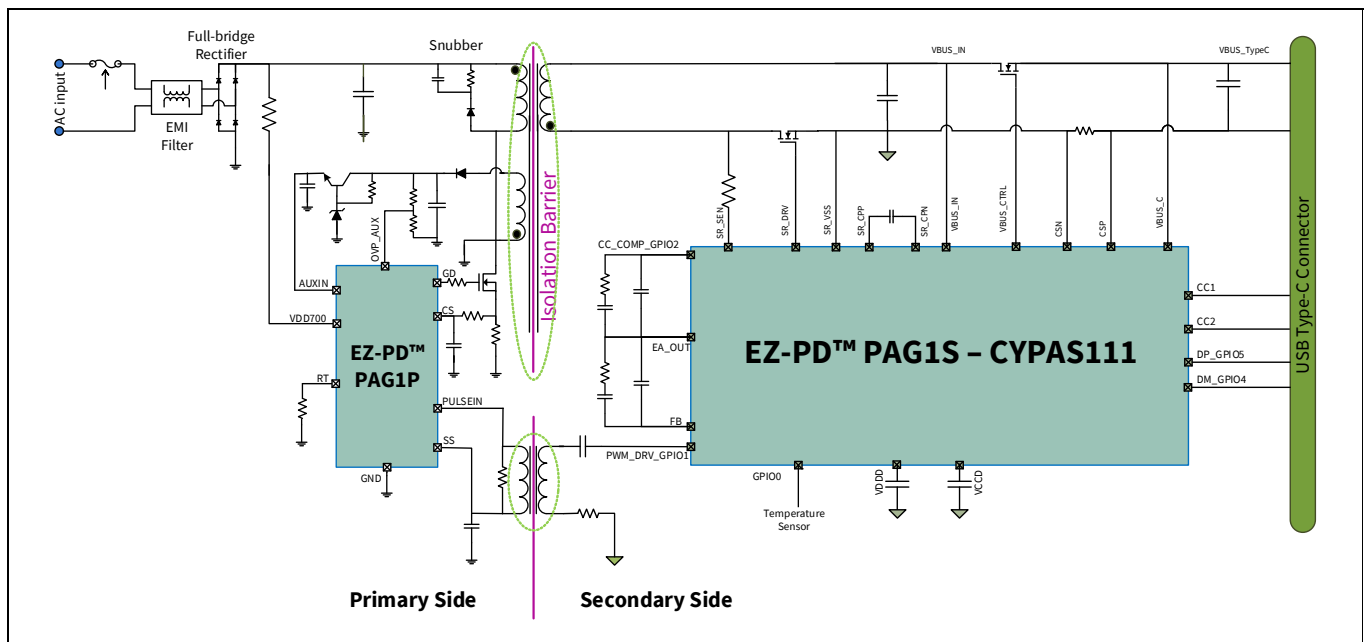

Figure 6 Power adapter with secondary side control application diagram

3 Functional description

3.1 Start-up behavior

On power-up, the primary side start-up controller shall start controlling the primary switch using its soft start mechanism and provide sufficient current to charge the secondary side output capacitor and the startup current required for EZ-PD™ PAG1S. The secondary output voltage is the input power supply source of EZ-PD™ PAG1S. Once VBUS_IN voltage exceeds 3.3 V, EZ-PD™ PAG1S firmware will boot up and take control of the primary switch. EZ-PD™ PAG1S firmware boot up time is in the order of a few milliseconds.

Once the boot-up is complete, the firmware configures the error-amplifier to achieve 5 V secondary output and EZ-PD™ PAG1S will generate the PWM pulses accordingly. These pulses on PWM_DRV_GPIO1 are coupled to the primary start-up controller through a pulse transformer. On receiving the PWM pulses, the primary side start-up controller is expected to synchronize its internal oscillator with the PWM pulses and switch from start-up mode to secondary control mode. In the secondary control mode, the primary switch will be directly controlled by the PWM pulses generated by EZ-PD™ PAG1S.

3.2 Modes of operation

EZ-PD™ PAG1S supports multiple modes of operation: Quasi-Resonant (QR) or Critical Conduction Mode (CrCM), Valley Switching, Discontinuous Conduction Mode (DCM), and Burst mode for light load operations. Analog PWM smart algorithm allows the operation to automatically transition between modes based on the output power requirement. The mode of operation stays in CrCM for higher loads, moves to DCM for medium loads and switches to pulse skip or burst mode for low and ultra-low power loads (see [Figure 7](#)). There are configurable options for minimum/maximum pulse width, minimum/maximum period and pulse skip or burst levels.

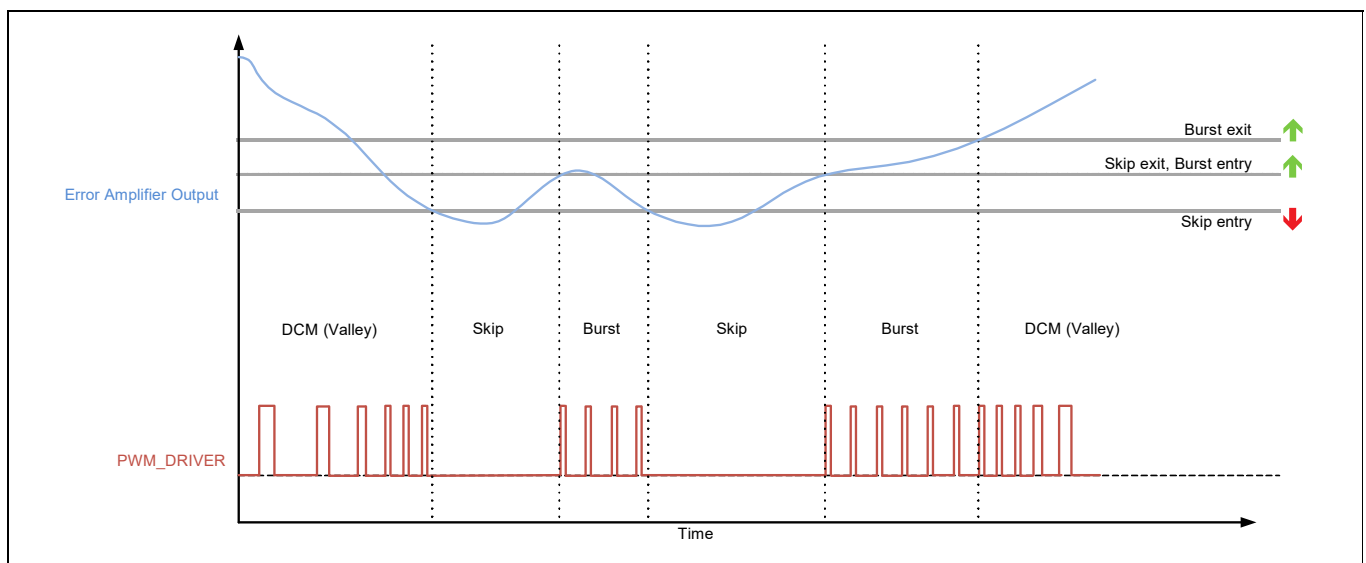

Figure 7 Error amplifier output vs modes of operation

3.3 Fault protection

3.3.1 VBUS UVP and OVP

VBUS undervoltage and overvoltage faults are monitored using internal VBUS_IN/VBUS_C resistor dividers. The fault thresholds and response times are configurable in EZ-PD™ PAG1S. Refer [EZ-PD™ Configuration Utility](#) for more details on the configuration utility.

3.3.2 VBUS OCP and SCP

VBUS overcurrent and short-circuit faults are monitored using internal current sense amplifiers. Same as OVP and UVP, the OCP and SCP fault thresholds and response times are configurable as well. Refer [EZ-PD™ Configuration Utility](#) for more details on the configuration utility.

3.3.3 OTP

Overtemperature monitoring is done using an external thermistor and internal ADC. The thermistor can be connected to any free GPIO. EZ-PD™ PAG1S contains one 8-bit SAR ADC, this is available for general purpose analog to digital conversions. The reference voltage to the ADC can be chosen from two sources: VDDD or a 2 V reference generated from internal bandgap.

3.3.4 ESD protection

EZ-PD™ PAG1S offers ESD protection on all the pins. The ESD protection level is 2.2-kV HBM and 500-V CDM.

3.3.5 VBUS to CC short protection

EZ-PD™ PAG1S offers protection against accidental short from VBUS_C pin short to CC.

3.4 Power modes

EZ-PD™ PAG1S supports multiple power modes - Active, Sleep, and DeepSleep. Transitions between these modes is handled by the application firmware depending on the operating conditions.

4 Electrical specifications

4.1 Absolute maximum ratings

Table 3 Absolute maximum ratings^[1]

Parameter	Description	Min	Typ	Max	Unit	Details/conditions
V _{BUS_IN_MAX}	Maximum input supply voltage	-	-	24	V	-
V _{DDD_MAX}	Maximum supply voltage	-	-	6		-
V _{SR_DRAIN_MAX}	Maximum voltage on SR_SEN pin	-	-	24		-
V _{GPIO_ABS}	GPIO voltage	-0.5	-	V _{DDD} + 0.5		-
V _{CC_PIN_ABS}	Maximum voltage on CC1, CC2 voltage	-	-	24		-
I _{GPIO_ABS}	Current per GPIO	-	-	25	mA	-
ESD_HBM	Electrostatic discharge human body model	2200	-	-	V	-
ESD_CDM	Electrostatic discharge charged device model	500	-	-		-
I _{LU}	Pin current for latch-up	-100	-	100	mA	-

Note

- Usage of the above absolute maximum conditions listed in [Table 3](#) may cause permanent damage to the device. Exposure to absolute maximum conditions for extended periods of time may affect device reliability. The maximum storage temperature is 150°C in compliance with JEDEC Standard JESD22-A103, high temperature storage life. When used below absolute maximum conditions but above normal operating conditions, the device may not operate to specification.

Electrical specifications

4.2 Device-level specifications

Table 4 DC specifications

Spec ID	Parameter	Description	Min	Typ	Max	Unit	Details/conditions
SID.PWR.1	V _{DDD_REG}	V _{DDD} output for 5.5 V ≤ V _{BUS_IN} ≤ 21.5 V	4.6	5.0	5.4	V	I _{LOAD} = 0–50 mA
SID.PWR.2	V _{DDD_MIN}	V _{DDD} output for 3.3 V ≤ V _{BUS_IN} ≤ 5.5 V	V _{BUS_IN} – 0.3	–	–		
SID.PWR.3	V _{DDD_MAX}	Max supply voltage relative to V _{SS}	–	–	6		–40°C to +105°C T _A , Absolute Maximum
SID.PWR.4	V _{BUS_IN}	Power supply input voltage	3.3	–	21.5		–
SID.PWR.6	V _{CCD}	Output voltage for core logic	–	1.8	–	–	–
SID.PWR.8	C _{efc}	Bypass capacitor for V _{CCD}	0.8	1	1.2	μF	X5R ceramic or better
SID.PWR.9	C _{exc}	Decoupling capacitor for V _{DDD}	1.8	–	2.2		
SID.PWR.10	C _{exv}	Decoupling capacitor for V _{BUS_IN}	–	1	–		Decoupling capacitor required near the IC pin.
SID.PWR.10A	C _{excpp}	Capacitor between SR_CPP and SR_CPN pins	0.1	–	–		X5R ceramic or better
SID.PWR.15	I _{DD_A}	Active current from V _{BUS_IN} in Type-C attached state	–	25	–	mA	V _{BUS_IN} = 5 V, T _A = 25°C, CC1/CC2 in TX or RX, CPU at 24 MHz, SR/PWM at 100 kHz, EA/ADC/CSA/UVOV blocks ON.
SID.PWR.16	I _{DD_S_UA}	Sleep current from V _{BUS_IN} in Type-C attached state	–	3.5	–		V _{BUS_IN} = 5 V, T _A = 25°C, Type-C attached, CPU OFF, PWM/EA/ADC/UVOV blocks ON. CC, watchdog timer (WDT) wakeup ON. IMO at 24 MHz.
SID.PWR.16A	I _{DD_DS_UA}	Deep Sleep current from V _{BUS_IN} in Type-C unattached state	–	0.75	–		V _{BUS_IN} = 5 V, T _A = 25°C, Type-C unattached, CPU OFF, UVOV block ON, WDT Wakeup ON.
SID.PWR.17	V _{SR_DRAIN}	Voltage allowed on SR_SEN pin	–0.7	–	21.5	V	–

Table 5 AC Specifications

Spec ID	Parameter	Description	Min	Typ	Max	Unit	Details/conditions
SID.PWR.14	T _{sleep}	Wakeup from sleep mode	–	0	–	μs	–
SID.PWR.14A	T _{deepsleep}	Wakeup from deepsleep mode	–	35	–		

Electrical specifications

4.3 Functional block specifications

Table 6 ADC specifications

Spec ID	Parameter	Description	Min	Typ	Max	Unit	Details/conditions
DC specifications							
SID.ADC.1	Resolution	ADC resolution	-	8	-	Bits	-
SID.ADC.2	INL	Integral nonlinearity	-2.5	-	2.5	LSB	Reference voltage = VREF_ADC1
SYS.ADC.3	INL	Integral nonlinearity	-1.5	-	1.5		Reference voltage = VREF_ADC2
SYS.ADC.4	DNL	Differential nonlinearity	-2.5	-	2.5		Reference voltage = VREF_ADC1
SYS.ADC.5	DNL	Differential nonlinearity	-1.5	-	1.5		Reference voltage = VREF_ADC2
SYS.ADC.6	Gain Error	Gain error	-1.5	-	1.5		-
SYS.ADC.7	VREF_ADC1	ADC reference voltage	V _{DDmin}	-	V _{DDmax}	V	Reference voltage generated from V _{DD}
SYS.ADC.8	VREF_ADC2	ADC reference voltage	1.96	2.0	2.04		Reference voltage generate from bandgap
AC specifications							
SID.ADC.9	Slew_Max	Rate of change of sampled voltage signal	-	-	3	V/ms	Guaranteed by design

Table 7 Error amplifier

Spec ID	Parameter	Description	Min	Typ	Max	Unit	Details/conditions
DC specifications							
SID.DC.VR.1	V _R	VBUS voltage regulation accuracy	-	±3	±5	%	-
SID.DC.VR.2	I _{ka_off}	Off-state EA_OUT current	-	2.2	10	µA	-
SID.DC.VR.4	DNL_ndac	Differential nonlinearity of NMOS DAC	-1	-	1	LSB	-
SID.DC.VR.5	INL_ndac	Integral nonlinearity of NMOS DAC	-1.5	-	1.5		-
SID.DC.VR.6	Gain_error_ndac	Gain error of NMOS DAC	-8	-	8	%	-
SID.DC.VR.7	DNL_pdac	Differential nonlinearity of PMOS DAC	-0.5	-	0.5	LSB	-
SID.DC.VR.8	INL_pdac	Integral nonlinearity of PMOS DAC	-1	-	1		-
SID.DC.VR.9	Gain_error_pdac	Gain error of PMOS DAC	-8	-	8	%	-

Electrical specifications

Table 8 LSCSA, SCP

Spec ID	Parameter	Description	Min	Typ	Max	Unit	Details/conditions
DC specifications							
SID.LSCSA.1	Cin_inp	CSP input capacitance	-	-	10	pF	-
SID.LSCSA.2	Csa_Acc1	CSA accuracy with 5 mV < Vsense < 10 mV	-15	-	15	%	-
SID.LSCSA.3	Csa_Acc2	CSA accuracy with 10 mV < Vsense < 15 mV	-10	-	10		-
SID.LSCSA.4	Csa_Acc3	CSA accuracy with 15 mV < Vsense	-5	-	5		-
SID.LSCSA.5	SCP_6A	Short circuit trip point with threshold set to 6 A	5.4	6	6.6	A	Rsense = 5 mΩ
SID.LSCSA.6	SCP_10A	Short circuit trip point with threshold set to 10 A	9	10	11		
SID.LSCSA.8	Av	CSA gain values supported: 5,10, 20, 35, 50, 75, 125, 150	5	-	150	V/V	-
SID.VSP.1	V_short_trigger	Short-to-VBUS system-side clamping voltage on the CC pins	6	9	12	V	-
AC specifications							
SID.LSCSA.AC.1	Tocp_gate	Delay from OCP threshold trip to external NFET gate turn off	-	4.0	20	μs	-
SID.LSCSA.AC.2	Tscp_gate	Delay from SCP threshold trip to external NFET gate turn off	-	3.1	-		1 nF NFET gate capacitance
SID.LSCSA.AC.3	Tscp_gate_1	Delay from SCP threshold trip to external NFET power gate turn off	-	7.5	-		3 nF NFET gate capacitance

Table 9 VBUS UV, OV

Spec ID	Parameter	Description	Min	Typ	Max	Unit	Details/conditions
DC specifications							
SID.UVOV.1	VTHOV1	Over-Voltage threshold Accuracy, 4 V to 11 V	-3	-	3	%	-
SID.UVOV.2	VTHOV2	Over-Voltage threshold Accuracy, 11 V to 21.5 V	-3.2	-	3.2		-
SID.UVOV.3	VTHUV1	Under-Voltage threshold Accuracy, 3 V to 3.3 V	-4	-	4		-
SID.UVOV.4	VTHUV2	Under-Voltage threshold Accuracy, 3.3 V to 4.0 V	-3.5	-	3.5		-
SID.UVOV.5	VTHUV3	Under-Voltage threshold Accuracy, 4.0 V to 11 V	-3	-	3		-
SID.UVOV.6	VTHUV4	Under-Voltage threshold Accuracy, 11 V to 21.5 V	-2.9	-	2.9		-
AC specifications							
SID.UVOV.AC.1	Tov_gate	Delay from OV threshold trip to external NFET Power Gate Turn off	-	-	50	μs	-

Electrical specifications

Table 10 PD transceiver

Spec ID	Parameter	Description	Min	Typ	Max	Unit	Details/conditions
DC specifications							
SID.PD.1	Rp_std	Downstream facing port (DFP) CC termination for default USB power	64	80	96	μA	-
SID.PD.2	Rp_1.5A	DFP CC termination for 1.5 A USB power	166	180	194		-
SID.PD.3	Rp_3.0A	DFP CC termination for 3.0 A USB power	304	330	356		-
SID.PD.4	Vgndoffset	Ground offset tolerated by BMC receiver	-500	-	500	mV	Relative to remote BMC transmitter

Table 11 VBUS discharge

Spec ID	Parameter	Description	Min	Typ	Max	Unit	Details/conditions
DC specifications							
SID.VBUS.DISC.1	R1	20 V NMOS ON resistance for discharge strength = 1	500	-	2000	Ω	Measured at 0.5 V
SID.VBUS.DISC.2	R2	20 V NMOS ON resistance for discharge strength = 2	250	-	1000		
SID.VBUS.DISC.3	R4	20 V NMOS ON resistance for discharge strength = 4	125	-	500		
SID.VBUS.DISC.4	R8	20 V NMOS ON resistance for discharge strength = 8	62.5	-	250		
SID.VBUS.DISC.5	R16	20 V NMOS ON resistance for discharge strength = 16	31.25	-	125		
SID.VBUS.DISC.6	Vbus_stop_error	Error percentage of final VBUS value	-	-	10		

Electrical specifications

Table 12 VBUS NFET gate driver

Spec ID	Parameter	Description	Min	Typ	Max	Unit	Details/conditions
DC specifications							
SID.GD.1	GD_VGS	Gate to source overdrive during NFET ON condition	4.5	5.75	10	V	$V_{BUS_IN} = 21.5\text{ V}$
SID.GD.2	GD_Rpd	Resistance when pull-down is enabled to turn off external NFET	-	0.57	2	k Ω	-
AC specifications							
AC.GD.1	Ton	V_{BUS_ctrl} Low to High (1 V to $V_{BUS} + 1\text{ V}$) with 3 nF external capacitance	2	5	10	ms	$V_{BUS_IN} = 5\text{ V}$
AC.GD.2	Toff	V_{BUS_ctrl} High to Low (90% to 10%) with 3 nF external capacitance	-	7	-	μs	$V_{BUS_IN} = 21.5\text{ V}$

Table 13 High-voltage regulator

Spec ID	Parameter	Description	Min	Typ	Max	Unit	Details/conditions
DC specifications							
SID.VREG.1	VOLTAGE_DETECT	VBUS_IN voltage detect threshold	1.7	2.1	2.4	V	-
SID.VREG.2	Tstart	Total start-up time for the regulator supply outputs	-	50	200	μs	From VBUS reaching Voltage_detect level to 95% of final value

Electrical specifications

Table 14 SR sense and driver

Spec ID	Parameter	Description	Min	Typ	Max	Unit	Details/conditions
DC specifications							
SR.1	VCPP1	Voltage doubler output for $3.3\text{ V} \leq \text{VBUS_IN} \leq 5.5\text{ V}$	5	-	-	V	-
SR.2	VCPP2	Voltage doubler output for $5.5\text{ V} \leq \text{VBUS_IN} \leq 21.5\text{ V}$	9	-	11		-
SR.3	TR_SR	Rise time (20% to 80%) of SR gate driver output with $\text{CL} = 6\text{ nF}$, $\text{VBUS_IN} = 3.3\text{ V}$, including doubler rise time (with and without double bypass mode)	-	-	150	ns	-
SR.4	TF_SR	Fall time (80% to 20%) of SR gate driver output with $\text{CL} = 6\text{ nF}$, $\text{VBUS_IN} = 3.3\text{ V}$, including doubler rise time (with and without double bypass mode)	-	-	100		-
SR.5	IIK_SR_VSS	Input leakage current on SR_VSS	-1	-	1	μA	-
SR.6	VTRIP_NSN_100	Negative sense trip voltage to turn-ON secondary switch	-140	-90	-60	mV	-
SR.7	VTRIP_ZCD	Negative sense trip voltage to turn-OFF secondary switch	-8	-5	-3		-
SR.8	TD_ON	Turn on propagation delay from SR_SEN at -100 mV to SR_GDRV reaching 1 V	-	25	50	ns	-
SR.9	TD_OFF	Turn off propagation delay from SR_SEN at -5 mV to SR_GDRV reaching 1 V	-	100	200		-
SR.10	IO_SRC_SNK	Output peak current (Source and sink)	-	1	-	A	-

Table 15 Analog PWM generator and pulse transformer driver

Spec ID	Parameter	Description	Min	Typ	Max	Unit	Details/conditions
DC specifications							
PWM.1	FSW	Switching frequency	20	-	150	kHz	-
PWM.2	PWM_ON	Minimum controllable ON time	100	-	-	ns	-

Electrical specifications

4.4 I/O specifications

Table 16 I/O specifications

Spec ID	Parameter	Description	Min	Typ	Max	Unit	Details/conditions
DC specifications							
SID.GIO.1	I_LU	Latch-up current limits	-140	-	140	mA	-
SID.GIO.2	RPU	Pull-up resistor value	3.5	5.6	8.5	kΩ	-
SID.GIO.3	RPD	Pull-down resistor value	3.5	5.6	8.5		-
SID.GIO.4	IIL	Input leakage current	-	-	2	nA	-
SID.GIO.5	CPIN_A	Max pin capacitance	-	-	22	pF	Capacitance on DP/DM lines
SID.GIO.6	CPIN	Max pin capacitance	-	3	7		Capacitance on all GPIOs, except DP/DM lines
SID.GIO.7	Voh_3V	Output voltage high level	$V_{DDD} - 0.6$	-	-	V	Ioh = -4 mA
SID.GIO.8	Vol_3V	Output voltage low level	-	-	0.6		Iol = 10 mA
SID.GIO.9	Vih_CMOS	Input voltage high threshold	$0.7 \times V_{DDD}$	-	-		-
SID.GIO.10	Vil_CMOS	Input voltage low threshold	-	-	$0.3 \times V_{DDD}$		-
SID.GIO.11	Vih_TTL	LVTTL input	2	-	-		-
SID.GIO.12	Vil_TTL	LVTTL input	-	-	0.8		-
SID.GIO.13	Vhysttl	Input hysteresis LVTTL	100	-	-	mV	-
SID.GIO.14	Vhyscmos	Input hysteresis CMOS	$0.05 \times V_{DDD}$	-	-		-
SID.GIO.15	IDIODE	Current through protection diode to V_{DDD}/V_{SS}	-	-	100	μA	-
SID.GIO.16	TriseF	Rise time in fast strong mode	2	-	12	ns	Load = 25 pF
SID.GIO.17	TfallF	Fall time in fast strong mode	2	-	12		
SID.GIO.18	TriseS	Rise time in slow strong mode	10	-	60		
SID.GIO.19	TfallS	Fall time in slow strong mode	10	-	60		
SID.GIO.20	FGPIO_OUT1	GPIO Fout; $3 V \leq V_{DDD} \leq 5.5V$; Fast strong mode.	-	-	16	MHz	-
SID.GIO.21	FGPIO_OUT2	GPIO Fout; $3V \leq V_{DDD} \leq 5.5 V$; Slow strong mode.	7	-	-		-
SID.GIO.22	FGPIO_IN	GPIO input operating frequency; $3 V \leq V_{DDD} \leq 5.5 V$	16	-	-		-

4.5 System resources specifications

Table 17 Power-on reset (POR) specifications

Spec ID	Parameter	Description	Min	Typ	Max	Unit	Details/conditions
SID.POR.1	VRISEIPOR	Power-on-reset (POR) rising trip voltage	0.8	–	1.5	V	–
SID.POR.2	VFALLIPOR	POR falling trip voltage	0.7	–	1.4		–
SID.POR.3	VFALLPPOR	Brown-out-detect (BOD) trip voltage Active/Sleep modes	1.48	–	1.62		–
SID.CLK#6	SR_POWER	Power supply slew rate	0.40	–	67	V/ms	On power-up and power-down

5 Ordering information

Table 18 EZ-PD™ PAG1S ordering information

MPN	Application	Package type	Si ID	Si Rev
CYPAS111A1-24LQXQ	USB Power Delivery adapter with secondary side control	24-pin QFN	2B01	A1
CYPAS111A1-24LQXQT				

5.1 Ordering code definitions

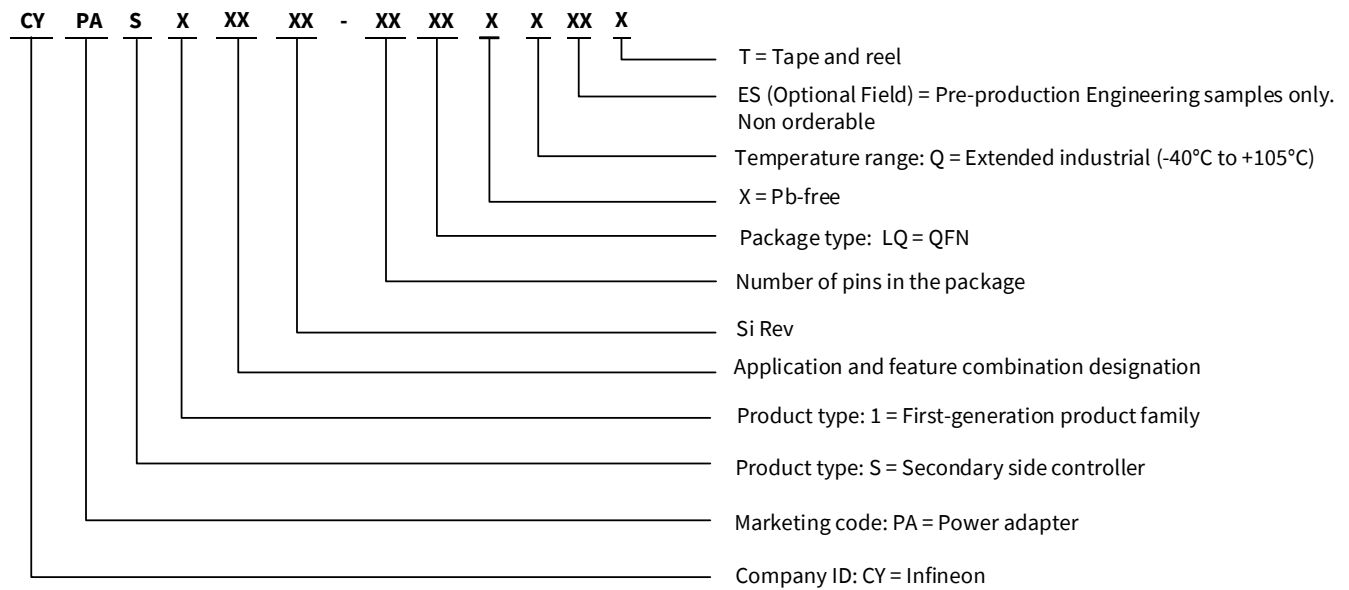

Packaging

6 Packaging

Table 19 Package characteristics

Parameter	Description	Conditions	Min	Typ	Max	Unit
T _A	Operating ambient temperature	Extended industrial	-40	25	105	°C
T _J	Operating junction temperature	Extended industrial	-40	25	120	
T _{JA}	Package θ _{JA}	-	-	-	19.98	°C/W
T _{JC}	Package θ _{JC}	-	-	-	4.78	

Table 20 Solder reflow peak temperature

Package	Maximum peak temperature	Maximum time within 5°C of peak temperature
24-pin QFN	260°C	30 seconds

Table 21 Package moisture sensitivity level (MSL), IPC/JEDEC J-STD-2

Package	MSL
24-pin QFN	MSL 3

Packaging

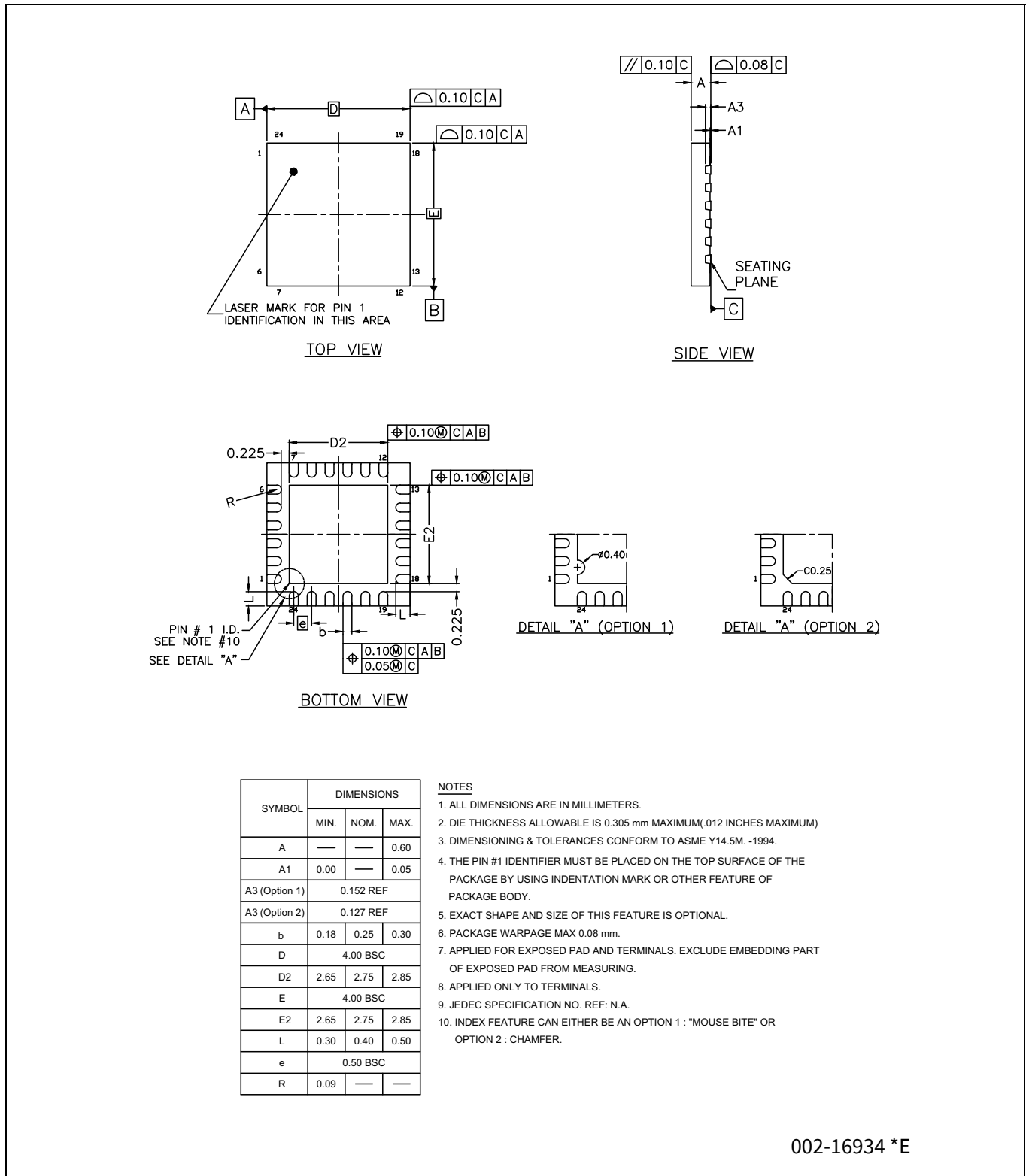

Figure 8 24-pin QFN ((4 x 4 x 0.6 mm), 2.75 x 2.75 mm EPAD (Sawn)) package outline, 002-16934

7 Acronyms

Table 22 Acronyms used in this document

Acronym	Description
ADC	analog-to-digital converter
API	application programming interface
Arm®	advanced RISC machine, a CPU architecture
CC	constant current
BOD	Brown out Detect
BMC	biphase mark code
CPU	central processing unit
CRC	cyclic redundancy check, an error-checking protocol
CS	current sense
DFP	downstream facing port
DIO	digital input/output, GPIO with only digital capabilities, no analog. See GPIO.
DRP	dual role port
EEPROM	electrically erasable programmable read-only memory
EMCA	a USB cable that includes an IC that reports cable characteristics (e.g., current rating) to the Type-C ports
EMI	electromagnetic interference
ESD	electrostatic discharge
FPB	flash patch and breakpoint
FS	full-speed
GPIO	general-purpose input/output
IC	integrated circuit
IDE	integrated development environment
I ² C, or IIC	Inter-Integrated Circuit, a communications protocol
ILO	internal low-speed oscillator, see also IMO
IMO	internal main oscillator, see also ILO
I/O	input/output, see also GPIO
LSCSA	low side current sense amplifier
LVD	low-voltage detect
LVTTL	low-voltage transistor-transistor logic
MCU	microcontroller unit
NC	no connect
NMI	nonmaskable interrupt
NMOS	N-type metal-oxide-semiconductor
NVIC	nested vectored interrupt controller
opamp	operational amplifier
OCP	overcurrent protection
OVP	overvoltage protection

Acronyms

Table 22 Acronyms used in this document (continued)

Acronym	Description
PCB	printed circuit board
PD	power delivery
PGA	programmable gain amplifier
PHY	physical layer
PMOS	P-type metal-oxide-semiconductor
POR	power-on reset
PRES	precise power-on reset
PSoC™	programmable system-on-chip
PWM	pulse-width modulator
RAM	random-access memory
RISC	reduced-instruction-set computing
RMS	root-mean-square
RTC	real-time clock
RX	receive
SAR	successive approximation register
SCL	I ² C serial clock
SDA	I ² C serial data
S/H	sample and hold
SPI	Serial Peripheral Interface, a communications protocol
SRAM	static random access memory
SWD	serial wire debug, a test protocol
TX	transmit
Type-C	a new standard with a slimmer USB connector and a reversible cable, capable of sourcing up to 100 W of power
UART	Universal Asynchronous Transmitter Receiver, a communications protocol
USB	Universal Serial Bus
WDT	watchdog timer
USBIO	USB input/output, CCG5 pins used to connect to a USB port
XRES	external reset I/O pin

8 Document conventions

8.1 Units of measure

Table 23 Units of measure

Symbol	Unit of measure
°C	degrees Celsius
Hz	hertz
KB	1024 bytes
kHz	kilohertz
kΩ	kilo ohm
Mbps	megabits per second
MHz	megahertz
MΩ	mega-ohm
Msps	megasamples per second
μA	microampere
μF	microfarad
μs	microsecond
μV	microvolt
μW	microwatt
mA	milliampere
ms	millisecond
mV	millivolt
nA	nanoampere
ns	nanosecond
Ω	ohm
pF	picofarad
ppm	parts per million
ps	picosecond
s	second
sps	samples per second
V	volt

Revision history

Revision history

Document version	Date of release	Description of changes
*B	2019-08-19	Changed document status from Preliminary to Final.
*C	2022-05-18	Updated Ordering information : Updated part numbers. Updated Packaging : spec 002-16934 – Changed revision from *B to *E. Migrated to Infineon template.
*D	2022-06-16	Updated Electrical specifications : Updated Device-level specifications : Updated Table 4 : Changed maximum value of Cexc parameter from 4.7 μF to 2.2 μF. Updated System resources specifications : Updated Table 17 : Added SR_POWER parameter and its corresponding details. Completing Sunset Review.

Trademarks

All referenced product or service names and trademarks are the property of their respective owners.

Edition 2022-06-16
Published by
Infineon Technologies AG
81726 Munich, Germany

© 2022 Infineon Technologies AG.
All Rights Reserved.

Do you have a question about this document?
Go to www.infineon.com/support

Document reference
002-27665 Rev. *D

IMPORTANT NOTICE

The information given in this document shall in no event be regarded as a guarantee of conditions or characteristics ("Beschaffenhheitsgarantie").

With respect to any examples, hints or any typical values stated herein and/or any information regarding the application of the product, Infineon Technologies hereby disclaims any and all warranties and liabilities of any kind, including without limitation warranties of non-infringement of intellectual property rights of any third party.

In addition, any information given in this document is subject to customer's compliance with its obligations stated in this document and any applicable legal requirements, norms and standards concerning customer's products and any use of the product of Infineon Technologies in customer's applications.

The data contained in this document is exclusively intended for technically trained staff. It is the responsibility of customer's technical departments to evaluate the suitability of the product for the intended application and the completeness of the product information given in this document with respect to such application.

For further information on the product, technology, delivery terms and conditions and prices please contact your nearest Infineon Technologies office (www.infineon.com).

WARNINGS

Due to technical requirements products may contain dangerous substances. For information on the types in question please contact your nearest Infineon Technologies office.

Except as otherwise explicitly approved by Infineon Technologies in a written document signed by authorized representatives of Infineon Technologies, Infineon Technologies' products may not be used in any applications where a failure of the product or any consequences of the use thereof can reasonably be expected to result in personal injury.

Looking for pricing, stock, or lifecycle information?

Click below to explore more details on WIN SOURCE:

- ⊖ [View CYPAS111A1-24LQXQT on WIN SOURCE](#)
- ⊖ [Infineon Technologies Information](#)

Optimize Your Supply Chain with WIN SOURCE Solutions

- ✓ Global Sourcing Solution
- ✓ Obsolete Management
- ✓ Cost Control Management
- ✓ Shortage Management
- ✓ Alternative Solution
- ✓ Excess Inventory Management