



Please note that Cypress is an Infineon Technologies Company.

The document following this cover page is marked as “Cypress” document as this is the company that originally developed the product. Please note that Infineon will continue to offer the product to new and existing customers as part of the Infineon product portfolio.

Continuity of document content

The fact that Infineon offers the following product as part of the Infineon product portfolio does not lead to any changes to this document. Future revisions will occur when appropriate, and any changes will be set out on the document history page.

Continuity of ordering part numbers

Infineon continues to support existing part numbers. Please continue to use the ordering part numbers listed in the datasheet for ordering.

High-Performance Programmable Oscillators

Features

- Low-noise PLL for integrated crystal applications
- Differential Clock Output: re-configurable through I²C
- Output frequency support from 15 MHz to 2.1 GHz
- Fractional N PLL with fully integrated VCO
- Works on an integrated fixed frequency crystal
- LVPECL, LVDS, HCSL, and CML output standards available
- Compatible with 3.3 V, 2.5 V, and 1.8 V supply
- 150 fs typical integrated jitter performance (12 kHz to 20 MHz frequency offsets) for outputs greater than 150 MHz
- VCXO functionality provided with tunable Total Pull Range (TPR) from ±50 ppm to ±275 ppm
- 8-pin LCC package 7.0 × 5.0 (CY2941x) or 5.0 × 3.2 (CY2942x) mm

Functional Description

The CY2941x/CY2942x is a programmable PLL-based crystal oscillator solution with flexible output frequency options. It is field or factory-programmable for any output frequency between 15 MHz and 2.1 GHz. Other frequency options can be configured with the I²C interface. Using advanced design technology, it provides excellent jitter performance across the entire output frequency range, working reliably at supply voltages from 1.8 V to 3.3 V for ambient temperatures from -40 °C to +105 °C. This makes it ideally suited for communications applications (for example, OTN, SONET/SDH, xDSL, GbE, networking, wireless infrastructure), test and instrumentation applications, and high-speed data converters. Additionally, the VCXO function enables use of the CY2941x/CY2942x series in applications requiring a clock source with voltage control, and in discrete clocking solutions for synchronous timing applications.

The CY2941x/CY2942x device configuration can be created using [ClockWizard 2.1](#). For programming support, contact [Cypress technical support](#) or send an email to clocks@cypress.com.

For a complete list of related documentation, click [here](#).

Logic Block Diagram

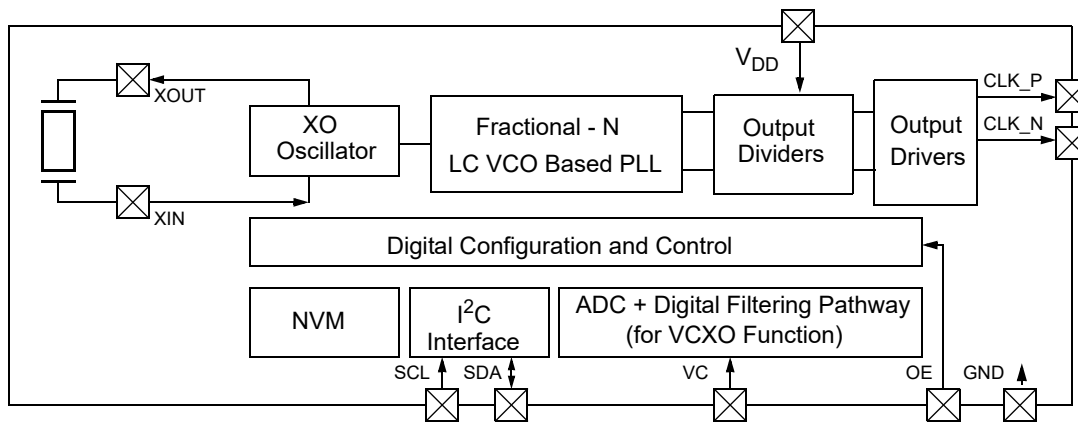

Contents

Pin Diagrams	3	AC Electrical Specifications for HCSL Output	10
Pin Description	3	Timing Parameters	10
Functional Overview	4	Phase Jitter Characteristics	11
Programmable Features	4	I2C Bus Timing Specifications	11
Architecture Overview	4	Frequency Stability	12
Internal State Diagram	4	Voltage and Timing Definitions	13
Small/Large Change	5	Phase Noise Plots	15
Programming Support	5	Ordering Information	18
Programmable OE Polarity	5	Ordering Code Definitions	18
Programmable VCXO	5	Package Diagrams	19
Power Supply Sequencing	5	Acronyms	21
I2C Interface	5	Document Conventions	21
Memory Map	5	Units of Measure	21
Absolute Maximum Ratings	6	Document History Page	22
Recommended Operating Conditions	6	Sales, Solutions, and Legal Information	23
DC Electrical Specifications	6	Worldwide Sales and Design Support	23
DC Specifications for LVDS Output	7	Products	23
DC Specifications for LVPECL Output	7	PSoC® Solutions	23
DC Specifications for CML Output	7	Cypress Developer Community	23
DC Specifications for HCSL Output	7	Technical Support	23
VCXO Specific Parameters	8		
AC Electrical Specifications			
for LVPECL, LVDS, CML Outputs	9		

Pin Diagrams

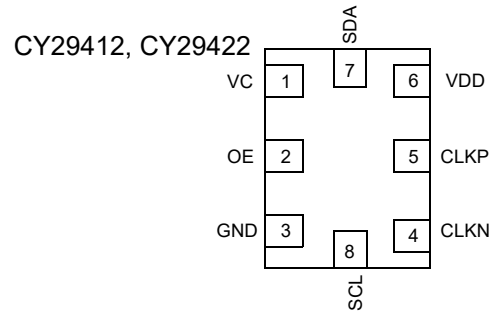
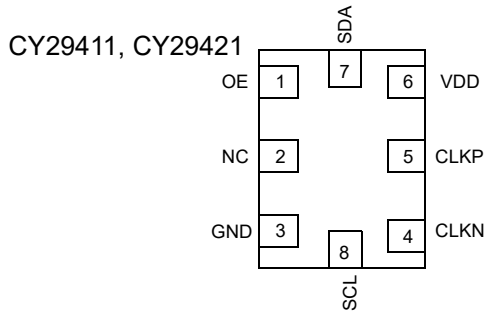

Pin Description

Name	Pin Number	Description
CY29411/CY29421 (8-pin LCC)		
OE	1	Output Enable input
NC	2	Not connected
GND	3	Supply ground
CLKN	4	Complement clock output
CLKP	5	True clock output
V _{DD}	6	Power supply
SDA	7	Serial data input/output
SCL	8	Serial clock input for I ² C
CY29412/CY29422 (8-pin LCC)		
VC ⁽¹⁾	1	Input voltage for VCXO
OE	2	Output enable input
GND	3	Supply ground
CLKN	4	Complement clock output
CLKP	5	True clock output
V _{DD}	6	Power supply
SDA	7	Serial data input/output
SCL	8	Serial clock input for I ² C

Note

1. If VC is unused, do not leave it floating; connect it to VDD or GND.

Functional Overview

Programmable Features

Table 1. Programmable Features

Feature	Details
Frequency Tuning	Frequency for the PLL
	Oscillator tuning (load capacitance values)
Function	OE Polarity, I ² C Address
Power Supply	V _{DD} (1.8, 2.5, or 3.3 V)
VCXO	Enable/Disable VCXO
	Kv Polarity
	TPR
	Modulation Bandwidth
Output Standard	LVPECL, LVDS, HCSL, CML

Architecture Overview

The CY2941x/CY2942x devices are high-performance programmable PLL crystal oscillators supporting multiple functions and multiple output standards. The device has internal one-time programmable (OTP) nonvolatile memory (NVM) that can be partitioned into Common Device Configurations and Output frequency-related information (see [Figure 2](#)). The Common Device Configurations do not change with output frequency and consist of chip power supply, OE polarity, I²C device address, input reference, output standard, and VCXO. The CY2941x/CY2942x devices also contain volatile memory (shown as “NVMCopy” in [Figure 1](#)) that stores an exact copy of the NVM at the release of reset on Power ON. The Chip settings depend on the contents of the volatile memory and the output frequency depends on the configurations stored in it, as explained in [Figure 1](#). The volatile memory can be accessed through the I²C bus and modified.

Figure 1. NVM and Volatile Memory Structure

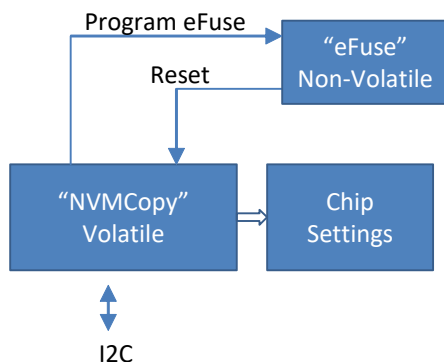

[Figure 2](#) shows the conceptual internal memory structure that consists of Frequency Profile and Common Device Configuration settings.

Figure 2. Memory Structure

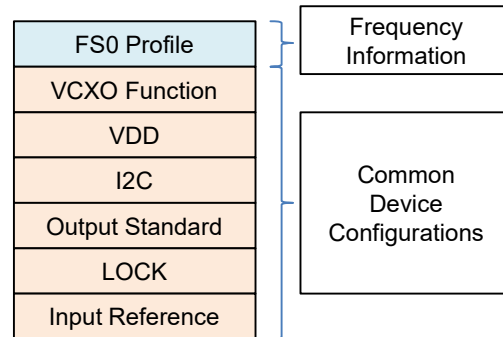

Description of Settings for the Memory Structure

- FS0: Contains frequency information
- VCXO Function: Contains parameters related to VCXO functionality, enable/disable, TPR, modulation bandwidth and Kv (Slope for VC vs. Frequency) information
- V_{DD}: 1.8-/2.5-/3.3-V range information
- I²C address: I²C address (programmable) information
- Output Standard: LVPECL, LVDS, HCSL or CML
- LOCK: 2-bit pattern to indicate NVM lock
- Input Reference: Information is Fixed, cannot be modified by the user

Internal State Diagram

The CY2941x/CY2942x contains a state machine which controls the device behavior. The state machine loads the “eFuse” contents to “NVMCopy” after reset as indicated in the [Figure 3 on page 5](#). The state machine enters one of the following states: “Command Wait state” or “Active state” according to the value of LOCK. In the “Command Wait state” state, user may access all the registers and read/write the “NVMCopy” contents. The following commands can be used in the “Command Wait state”:

The LOCK state is determined by a 2-bit pattern: 00, 01, 10, or 11. When the Power rail reaches a value within the specified range, the device comes out of the Reset state.

The blank device has LOCK=“00” (NVM not locked) in [Figure 3 on page 5](#) so that it goes to the “Command Wait state” after coming out of Reset. The State machine will wait for the following commands:

- Write to volatile memory
- Program Non-Volatile memory (NVM)
- Loop Lock

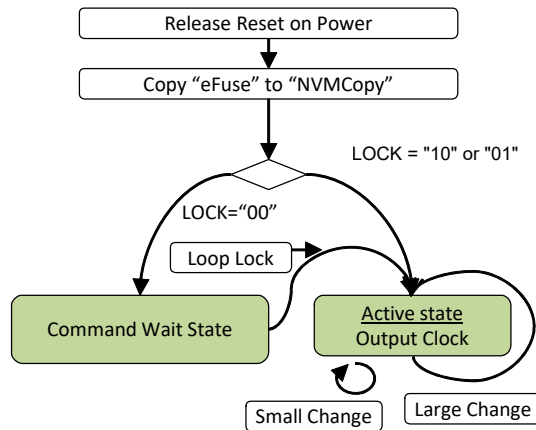
Figure 3. State Diagram

When the LOCK is programmed to "10" or "01", the device will go to the "Active state" and the device will perform at the programmed frequency.

In the "Command Wait state", you can configure the device with or without writing to the NVM. The use case scenarios are as follows:

- Test output frequency
 - Write to volatile memory and selectively write to NVM if needed
 - Proceed to Loop Lock can optionally be done for testing purpose

In the NVM locked state, the NVM cannot be reprogrammed. If needed, the output frequency may be changed using Large or Small change commands.

Small/Large Change

Small Change indicates that the frequency is changing within ± 500 ppm. The frequency information will be loaded through I²C and the output frequency will change without any glitch from its original frequency to the new frequency. For more information, see [AC Electrical Specifications for LVPECL, LVDS, CML Outputs](#).

Large Change indicates that the frequency is changing more than ± 500 ppm and is done through the I²C interface. The device will recalibrate and reconfigure the PLL. The output will be differential Low synchronously until this process is completed.

Programming Support

The CY2941x/CY2942x is a software-configurable solution, in which Cypress provides programming software to users to configure the programmable features of the device based on their requirements.

Programmable OE Polarity

The CY2941x/CY2942x contains a bit for OE polarity setting (default is active low). You can choose active-high or active-low polarity for the OE function. The output will be differential Low synchronously when OE is deasserted.

Programmable VCXO

The device incorporates a proprietary technique for modulating frequency by modifying the VCO frequency based on the VC control voltage. The pull profile is linear and accurate compared to pulling the crystal reference. Also, the VCXO characteristics are very stable and do not vary over temperature, supply voltage, or process variations.

Kv (Slope for frequency vs. VC), TPR VC bandwidth, and VCXO on/off are programmable.

Power Supply Sequencing

The CY2941x/CY2942x does not require any specific sequencing for startup. Startup requires a monotonic V_{DD} ramp specified in the datasheet. After the ramp up, V_{DD} has to be maintained within the limits specified for it in the Recommended Operating Conditions. Brownout detection and protection has to be implemented elsewhere in the system.

Other input signals can power up earlier or later than V_{DD}, there is no timing requirement for the input signals with reference to V_{DD}. The device will operate normally when all the input signals are settled to the configured state.

I²C Interface

The CY2941x/CY2942x supports two-wire serial interface (I²C) in Fast Mode (400 kbps) and 7-bit addressing. The device address is programmable and is 55h by default. It supports single-byte access only. The first I²C access to the device will be available at 5 ms (minimum) after VDD reaches its minimum specified voltage.

Memory Map

Table 2. Common Configurations

Memory Address	Descriptions
50h–57h	Device configurations

Table 3. FS0: Frequency Configurations

Memory Address	Descriptions
10h	DIVO
11h	DIVO, DIVN_INT
12h	ICP, DIVN_INT, PLL_MODE
13h	DIVN_FRAC_L
14h	DIVN_FRAC_M
15h	DIVN_FRAC_H

Table 4. Misc information

Memory Address	Description
00h (Read only)	Device ID (= 51h)
D4h–D6h	User configurable information

The user must write all the contents created by the Configuration tool. Partial updates to the device is not allowed. Access to locations other than those described here may cause fatal error in device operation.

Absolute Maximum Ratings

Exceeding maximum ratings^[2] may shorten the useful life of the device. User guidelines are not tested.

Supply voltage to ground potential-0.5 V to + 3.8 V
Input voltage-0.5 V to + 3.8 V
Storage temperature (non-condensing)	... -55 °C to +150 °C
Junction temperature -40 °C to +125 °C
Programming temperature 0 °C to +125 °C

Programming voltage2.5V ±0.1 V
Supply Current for eFuse Programming 50 mA
Data retention at T _J = 100 °C> 10 years
Maximum programming cycles1
ESD HBM (JEDEC JS-001-2012) 2000 V
ESD MM (JEDEC JESD22-A115B) 200 V
ESD CDM (JEDEC JESD22-C101E) 400 V
Latch-up current ±140 mA

Recommended Operating Conditions

Parameter	Description	Min	Max	Unit
V _{DD}	Core supply voltage, 1.8-V operating range, 1.8 V ± 5%	1.71	1.89	V
	Core supply voltage, 2.5-V operating range, 2.5 V ± 10%	2.25	2.75	
	Core supply voltage, 3.3-V operating range, 3.3 V ± 10%	2.97	3.63	
T _A	Ambient temperature	-40	+105	°C
UL-94	Flammability rating. V-0 at 1/8 in.	-	10	ppm
f _{RES}	Frequency resolution	-	2	ppb
T _{PLLHOLD}	PLL Hold Temperature Range	-	125	°C

DC Electrical Specifications

Parameter	Description	Test Conditions	Min	Typ	Max	Unit
I _{DD}	Supply current, LVPECL	V _{DD} = 3.3 V/2.5 V, 50 Ω to V _{TT} (V _{DD} - 2.0 V), with common mode current	-	93	106	mA
	Supply current, LVPECL	V _{DD} = 3.3 V/2.5 V, 50 Ω to V _{TT} (V _{DD} - 2.0 V), without common mode current ^[3]	-	81	94	
	Supply current, LVDS	V _{DD} = 3.3 V/2.5 V/1.8 V, 100 Ω between CLKP and CLKN	-	69	81	
	Supply current, HCSL	V _{DD} = 3.3 V/2.5 V/1.8 V, 33 Ω and 49.9 Ω to GND	-	80	93	
	Supply current, CML	V _{DD} = 3.3 V/2.5 V/1.8 V, 50 Ω to V _{DD}	-	73	86	
	Supply current, PLL only	V _{DD} = 3.3 V/2.5 V/1.8 V	-	59	70	
I _{IH}	Input high current	Logic input, Input = V _{DD}	-	30	50	μA
I _{IL}	Input low current	Logic input, Input = GND	-	30	50	μA
V _{IH} ^[4]	Input high voltage	OE, SCL, SDA logic level = 1	0.7 × V _{DD}	-	-	V
V _{IL} ^[4]	Input low voltage	OE, SCL, SDA logic level = 0	-	-	0.3 × V _{DD}	V
V _{IN}	Input voltage level	All input, relative to GND	-0.5	-	3.8	V
R _P	Internal pull-up resistance	OE, configured active High	-	200	-	kΩ
R _D	Internal pull-down resistance	OE, configured active Low	-	200	-	kΩ

Notes

- Stresses beyond those listed under [Absolute Maximum Ratings](#) may cause permanent damage to the device. These are stress ratings only and functional operation of the device at these or at any other conditions beyond those indicated under [Recommended Operating Conditions](#) is not implied. Exposure to Absolute-Maximum-Rated conditions for extended periods may affect device reliability or cause permanent device damage.
- In [ClockWizard 2.1](#), setting the output standard to LVPECL2 configures the output to "LVPECL without common mode current". Refer to [AN210253](#) for LVPECL terminations for different use case configurations.
- I²C operation applicable for V_{DD} of 1.8 V and 2.5 V only.

DC Specifications for LVDS Output

(V_{DD} = 1.8-V, 2.5-V, or 3.3-V range)

Parameter	Description	Conditions	Min	Typ	Max	Units
$V_{OCM}^{[5]}$	Output common-mode voltage	V_{DD} = 2.5-V or 3.3-V range	1.125	1.200	1.375	V
ΔV_{OCM}	Change in V_{OCM} between complementary output states	–	–	–	50	mV
I_{OZ}	Output leakage current	Output off, V_{OUT} = 0.75 V to 1.75 V	–20	–	20	μ A

DC Specifications for LVPECL Output

(V_{DD} = 2.5-V or 3.3-V range, with common mode current)

Parameter	Description	Conditions	Min	Typ	Max	Units
V_{OH}	Output high voltage	R-term = 50 Ω to V_{TT} (V_{DD} – 2.0 V)	V_{DD} – 1.165	–	V_{DD} – 0.800	V
V_{OL}	Output low voltage	R-term = 50 Ω to V_{TT} (V_{DD} – 2.0 V)	V_{DD} – 2.0	–	V_{DD} – 1.55	V

DC Specifications for CML Output

(V_{DD} = 1.8-V, 2.5-V or 3.3-V range)

Parameter	Description	Conditions	Min	Typ	Max	Units
V_{OH}	Output high voltage	R-term = 50 Ω to V_{DD}	V_{DD} – 0.085	V_{DD} – 0.01	V_{DD}	V
V_{OL}	Output low voltage	R-term = 50 Ω to V_{DD}	V_{DD} – 0.6	V_{DD} – 0.4	V_{DD} – 0.32	V

DC Specifications for HCSL Output

(V_{DD} = 1.8-V, 2.5-V, or 3.3-V range)

Parameter	Description	Conditions	Min	Typ	Max	Units
$V_{MAX}^{[6]}$	Max output high voltage	Measurement taken from single-ended waveform	–	–	1150	mV
$V_{MIN}^{[6]}$	Min output low voltage	Measurement taken from single-ended waveform	–300	–	–	mV
V_{OHDIFF}	Differential output high voltage	Measurement taken from differential waveform	150	–	–	mV
V_{OLDIFF}	Differential output low voltage	Measurement taken from differential waveform	–	–	–150	mV
$V_{CROSS}^{[6]}$	Absolute crossing point voltage	Measurement taken from single-ended waveform	250	–	600	mV
$V_{CROSSDELTA}^{[6]}$	Variation of V_{CROSS} over all rising clock edges	Measurement taken from single-ended waveform	–	–	140	mV

Notes

- Requires external AC coupling for V_{DD} = 1.8-V range, as indicated in [Figure 9](#).
- Parameters are guaranteed by design and characterization. Not 100% tested in production.

V_{CXO} Specific Parameters

Parameter ^[7]	Description	Condition	Min	Typ	Max	Units
TPR	Total Pull Range	VC range $0.1 \times V_{DD}$ to $0.9 \times V_{DD}$	±50	–	±275	ppm
K _{BSL}	Best-fit Straight Line (BSL) linearity	Deviation from BSL line	–5	–	5	%
K _{INC}	Incremental linearity	Kv slope deviation	–10	–	10	%
K _{BW}	Bandwidth of Kv modulation	Programmable	5	10	20	kHz
K _{RANGE}	Voltage range	Permissible voltage range	0	–	V _{DD}	V
V _{CTYP}	Nominal center VC control voltage	V _{DD} configuration = 1.8 V	–	0.9	–	V
		V _{DD} configuration = 2.5 V	–	1.25	–	V
		V _{DD} configuration = 3.3 V	–	1.65	–	V
R _{VCIN} ^[8]	Input resistance for VC	–	5	–	–	MΩ
V _{RANGE}	Input voltage range	Linearity guaranteed range	$0.1 \times V_{DD}$	–	$0.9 \times V_{DD}$	V

Notes

7. Parameters are guaranteed by design and characterization. Not 100% tested in production.
8. RVCIN is 100% tested.

AC Electrical Specifications for LVPECL, LVDS, CML Outputs

($V_{DD} = 3.3\text{ V}$ and 2.5 V for LVPECL, with common mode current, and $V_{DD} = 3.3\text{ V}$, 2.5 V , and 1.8 V for LVDS and CML outputs)

Parameter ^[9]	Description	Details/Conditions	Min	Typ	Max	Unit
f_{OUT}	Clock Output Frequency	LVPECL, CML, LVDS output standards	15	–	2100	MHz
t_{RF}	LVPECL Output Rise/Fall Time	20% to 80% of AC levels. Measured at 156.25 MHz for PECL outputs.	–	–	350	ps
	CML Output Rise/Fall Time	20% to 80% of AC levels. Measured at 156.25 MHz for CML outputs.	–	–	350	ps
	LVDS Output Rise/Fall Time	20% to 80% of AC levels. Measured at 156.25 MHz for LVDS outputs.	–	–	350	ps
t_{ODC}	Output Duty Cycle	Measured at differential 50% level, 156.25 MHz.	45	50	55	%
V_P	LVDS output differential peak	15 MHz to 700 MHz	247	–	454	mV
V_P	LVDS output differential peak	700 MHz to 2100 MHz	150	–	454	mV
ΔV_P	Change in V_P between complementary output states	–	–	–	50	mV
V_P	LVPECL output differential peak	$f_{OUT} = 15\text{ MHz to }325\text{ MHz}$	450	–	–	mV
V_P		$f_{OUT} = 325\text{ MHz to }700\text{ MHz}$	350	–	–	mV
V_P		$f_{OUT} = 700\text{ MHz to }2100\text{ MHz}$	250	–	–	mv
V_P	CML output differential peak	$f_{OUT} = 15\text{ MHz to }700\text{ MHz}$	250	–	600	mV
V_P	CML output differential peak	$f_{OUT} = 700\text{ MHz to }2100\text{ MHz}$	200	–	600	mV
t_{CCJ}	Cycle to Cycle Jitter	pk, measured at differential signal, 156.25 MHz, over 10k cycles, 100 MHz–130 MHz crystal	–	–	50	ps
t_{PJ}	Period Jitter	pk-pk, measured at differential signal, 156.25 MHz, over 10k cycles, 100 MHz–130 MHz crystal	–	–	50	ps
J_{RMS}	RMS Phase Jitter	$f_{OUT} = 156.25\text{ MHz}$, 12 kHz–20 MHz offset, non-VCXO mode	–	150	250	fs
Non-VCXO Mode						
PN1k	Phase Noise, 1 kHz Offset	100-130 MHz crystal reference, $f_{OUT} = 156.25\text{ MHz}$	–	–	-113	dBc/Hz
PN10k	Phase Noise, 10 kHz Offset	100-130 MHz crystal reference, $f_{OUT} = 156.25\text{ MHz}$	–	–	-127	dBc/Hz
PN100k	Phase Noise, 100 kHz Offset	100-130 MHz crystal reference, $f_{OUT} = 156.25\text{ MHz}$	–	–	-135	dBc/Hz
PN1M	Phase Noise, 1MHz Offset	100-130 MHz crystal reference, $f_{OUT} = 156.25\text{ MHz}$	–	–	-144	dBc/Hz
PN10M	Phase Noise, 10 MHz Offset	100-130 MHz crystal reference, $f_{OUT} = 156.25\text{ MHz}$	–	–	-152	dBc/Hz
PN-SPUR	Spur	At frequency offsets equal to and greater than the update rate of the PLL	–	–	-65	dBc/Hz

Note

9. Parameters are guaranteed by design and characterization. Not 100% tested in production.

AC Electrical Specifications for HCSL Output

Parameter ^[10]	Description	Test Conditions	Min	Typ	Max	Units
f_{OUT}	Output frequency	HCSL	15	–	700	MHz
E_R	Rising edge rate	Measured taken from differential waveform, –150 mV to +150 mV	0.6	–	5.7 ^[11]	V/ns
E_F	Falling edge rate	Measured taken from differential waveform, –150 mV to +150 mV	0.6	–	5.7 ^[11]	V/ns
t_{STABLE}	Time before voltage ring back (VRB) is allowed	Measured taken from differential waveform, –150 mV to +150 mV	500	–	–	ps
R-F_MATCHING	Rise-Fall matching	Measured taken from single-ended waveform, rising edge rate to falling edge rate matching, 100 MHz	–100	–	100	ps
t_{DC}	Output duty cycle	Measured taken from differential waveform, $f_{OUT} = 100$ MHz	45	–	55	%
t_{CCJ}	Cycle to Cycle Jitter	Measured taken from differential waveform, 100 MHz	–	–	50	ps
$J_{RMSPCIE}$	Random jitter, PCIE Specification 3.0	100 MHz–130 MHz crystal	–	–	1	ps (RMS)

Timing Parameters

Parameter ^[10]	Description	Min	Max	Unit
t_{PU}	Supply ramp time (0.5 V to $V_{DD(min)}$). Power ramp must be monotonic.	0.01	3000	ms
t_{WAKEUP}	Time from minimum specified power supply to <math>\pm 0.1 <td>–</td> <td>10</td> <td>ms</td>	–	10	ms
t_{OEEN}	Time from OE edge to output enable	–	2.5	ms
t_{OEDIS}	Time for OE edge to output disable	–	10	μ s
t_{FSMALL}	Frequency change time for small trigger ($\leq \pm 500$ ppm) with $\pm 1\%$ target frequency	–	20	μ s
t_{FLARGE}	Frequency change time for large trigger ($> \pm 500$ ppm)	–	2.5	ms

Notes

10. Parameters are guaranteed by design and characterization. Not 100% tested in production.
 11. Edge rates are higher than 4 V/ns due to jitter performance requirements.

Phase Jitter Characteristics

12 kHz to 20 MHz Integration Bandwidth

Parameter ^[12]	Description	Condition	Min	Typ	Max	Units
Non VCXO functionality						
J _{RMS}	RMS jitter	F _{OUT} = 644.53 MHz	–	110	–	fs
J _{RMS}	RMS jitter	F _{OUT} = 622.08 MHz	–	120	–	fs
J _{RMS}	RMS jitter	F _{OUT} = 156.25 MHz	–	145	–	fs
J _{RMS}	RMS jitter	F _{OUT} = 2.105 GHz	–	145	–	fs
Modulation bandwidth = 10 kHz, V _{DD} = 3.3 V, F _{OUT} = 622.08 MHz						
J _{RMS}	RMS jitter	TPR = 50 ppm, Kv = 37.9 ppm/V	–	151	–	fs
J _{RMS}	RMS jitter	TPR = 155 ppm, Kv = 117.4 ppm/V	–	158	–	fs
J _{RMS}	RMS jitter	TPR = 275 ppm, Kv = 208.3 ppm/V	–	170	–	fs
Modulation bandwidth = 10 kHz, V _{DD} = 2.5 V, F _{OUT} = 622.08 MHz						
J _{RMS}	RMS jitter	TPR = 50 ppm, Kv = 50 ppm/V	–	152	–	fs
J _{RMS}	RMS jitter	TPR = 155 ppm, Kv = 155 ppm/V	–	160	–	fs
J _{RMS}	RMS jitter	TPR = 275 ppm, Kv = 275 ppm/V	–	175	–	fs
Modulation bandwidth = 10 kHz, V _{DD} = 1.8 V, F _{OUT} = 622.08 MHz						
J _{RMS}	RMS jitter	TPR = 50 ppm, Kv = 69.4 ppm/V	–	153	–	fs
J _{RMS}	RMS jitter	TPR = 155 ppm, Kv = 215.3 ppm/V	–	166	–	fs
J _{RMS}	RMS jitter	TPR = 275 ppm, Kv = 381.9 ppm/V	–	190	–	fs

I²C Bus Timing Specifications

Parameter ^[12, 13]	Description	Min	Typ	Max	Units
f _{SCL}	SCL clock frequency	–	–	400	kHz
t _{HD:STA}	Hold time START condition	0.6	–	–	μs
t _{LOW}	Low period of SCL	1.3	–	–	μs
t _{HIGH}	High period of SCL	0.6	–	–	μs
t _{SU:STA}	Setup time for a repeated START condition	0.6	–	–	μs
t _{HD:DAT}	Data hold time	0	–	–	μs
t _{SU:DAT}	Data setup time	100	–	–	ns
t _R	Rise time	–	–	300	ns
t _F	Fall time	–	–	300	ns
t _{SU:STO}	Setup time for STOP condition	0.6	–	–	μs
t _{BUF}	Bus-free time between STOP and START conditions	1.3	–	–	μs

Notes

12. Parameters are guaranteed by design and characterization. Not 100% tested in production.
 13. I²C operation applicable for V_{DD} of 1.8 V and 2.5 V only.

Frequency Stability

Parameter	Description	Test Conditions	Min	Typ	Max	Units
$f_{\text{TOLERANCE}}$	Frequency Tolerance	$V_{\text{DD}} = \text{min to max,}$ $T_{\text{A}} = +25\text{ }^{\circ}\text{C}$	-20	-	+20	ppm
f_{TC}	Temperature Characteristics	$V_{\text{DD}} = \text{min to max,}$ $T_{\text{A}} = -40\text{ }^{\circ}\text{C to } +85\text{ }^{\circ}\text{C}$	-20	-	+20	ppm
f_{TC}	Temperature Characteristics	$V_{\text{DD}} = \text{min to max,}$ $T_{\text{A}} = -40\text{ }^{\circ}\text{C to } +105\text{ }^{\circ}\text{C}$	-30	-	+30	ppm
f_{AGE}	Frequency Aging		-5	-	+5	ppm/year

Voltage and Timing Definitions

Figure 4. Differential Output Definitions

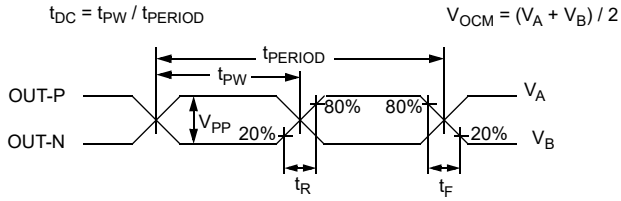

Figure 5. Output Enable/Disable Timing

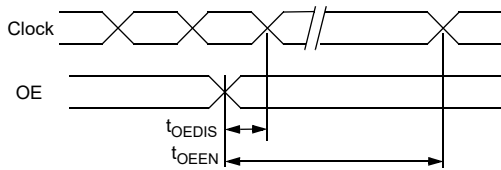

Figure 6. Power Ramp and PLL Lock Time

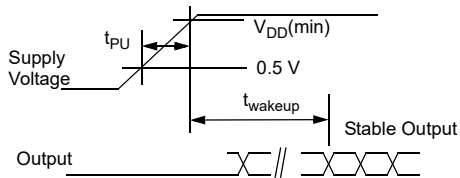

Figure 7. Output Termination Circuit

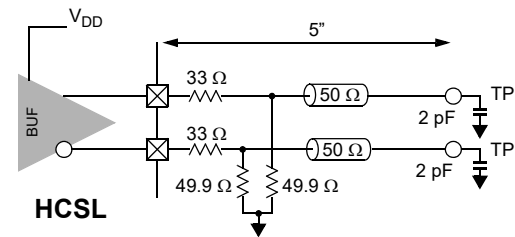
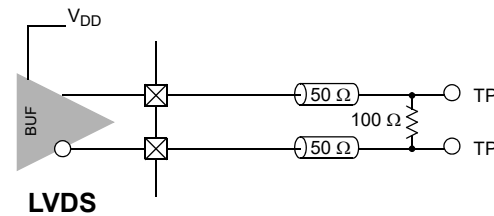
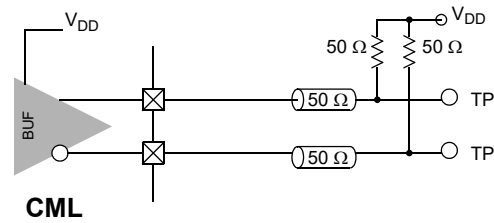
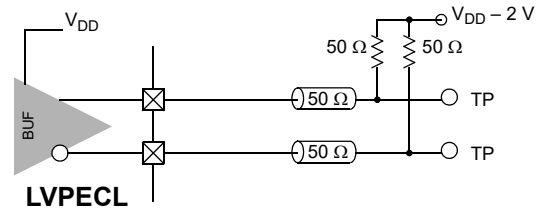
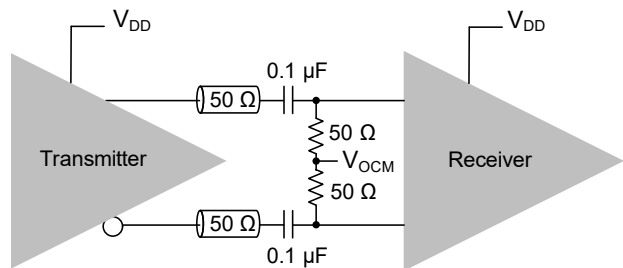

Figure 8. LVDS Termination for 1.8 V^[14]



Note

14. The termination circuit shown in this figure is specific to the LVDS output standard for $V_{DD} = 1.8\text{-V}$ operation. This needs AC coupling (100-nF series capacitor). The 50-ohm termination resistors along with the bias voltage (V_{OCM}) is required to be set at the destination circuit as shown in the figure.

Figure 9. HCSL: Single-ended Measurement Points for Absolute Crossing Point

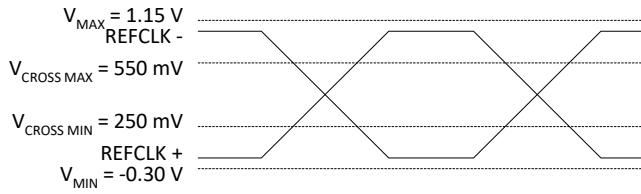

Figure 10. HCSL: Single-ended Measurement Points for Delta Crossing Point

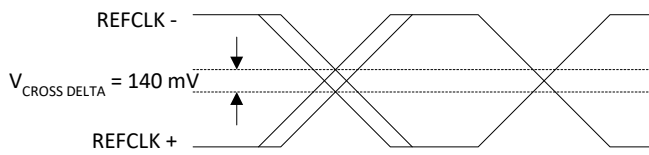

Figure 11. HCSL: Differential Measurement Points for Rise and Fall Time

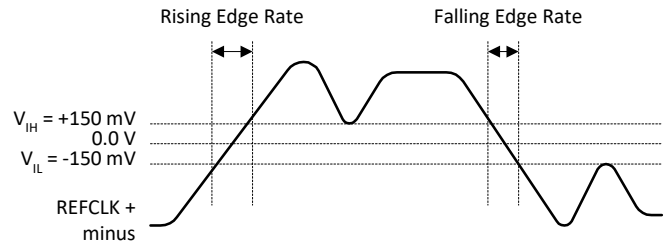

Figure 12. HCSL: Differential Measurement Points for Ring-back

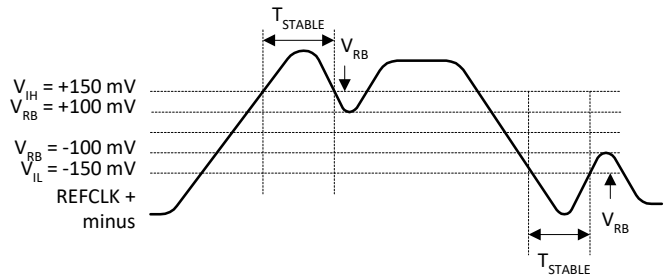
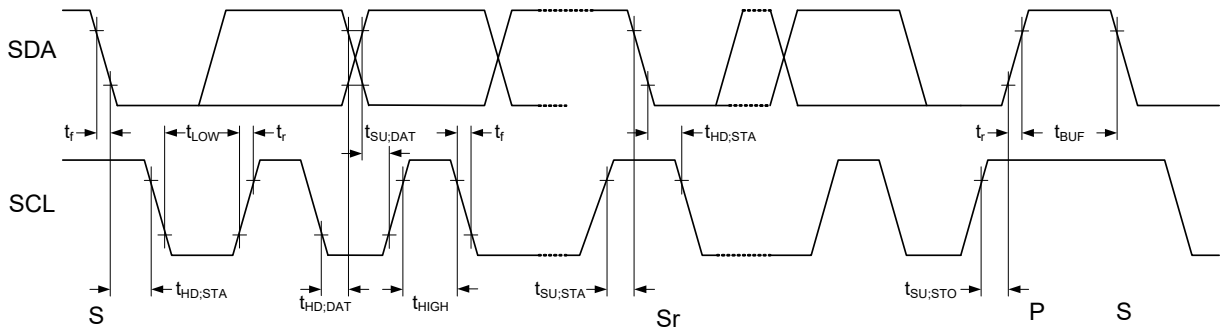

Figure 13. I²C Bus Timing Specifications



Phase Noise Plots

Figure 14. Typical Phase Noise at 156.25 MHz (12 kHz–20 MHz)

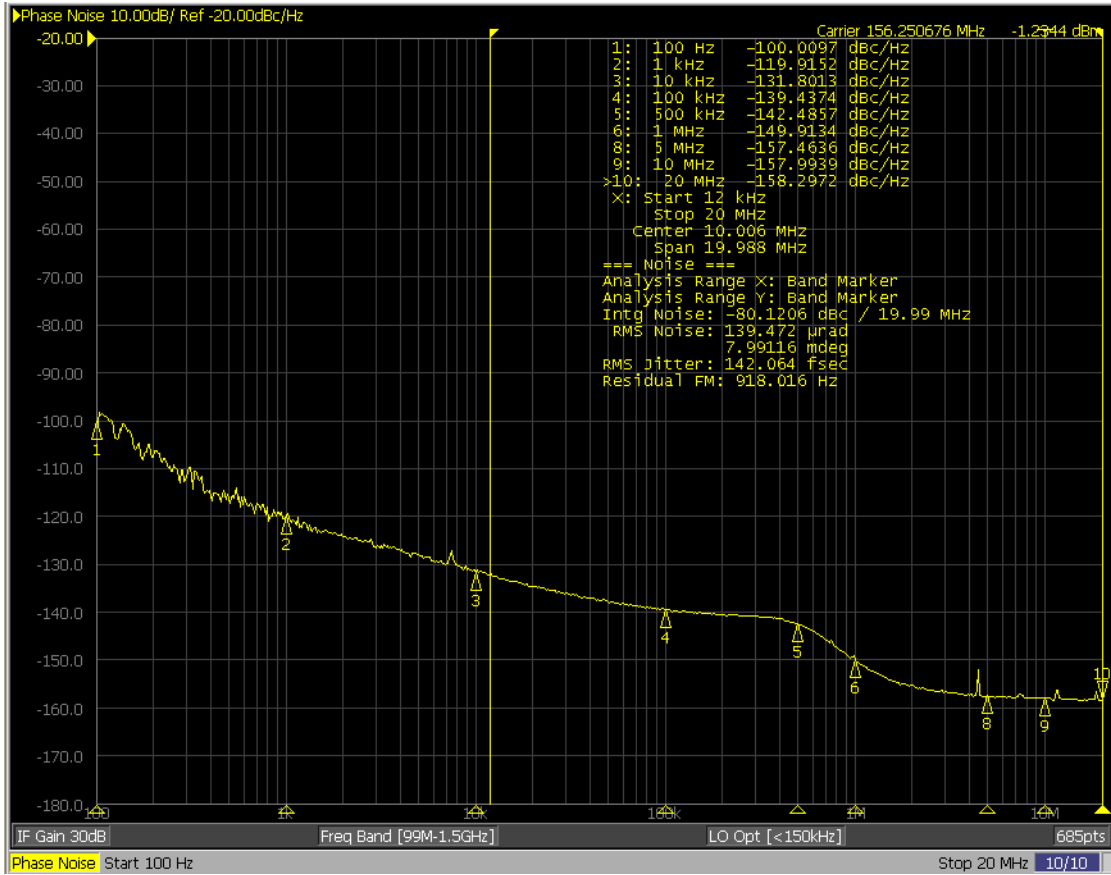

Figure 15. Typical Phase Noise at 622.08 MHz (12 kHz–20 MHz)

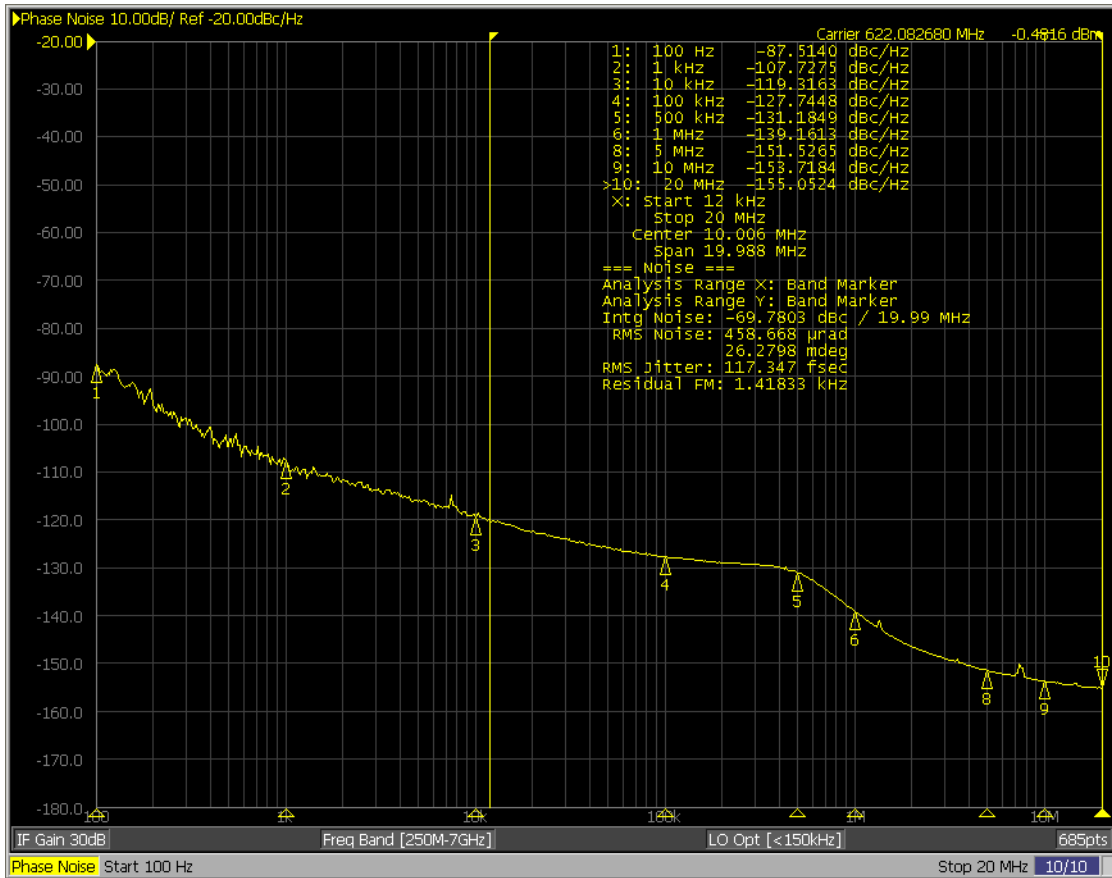
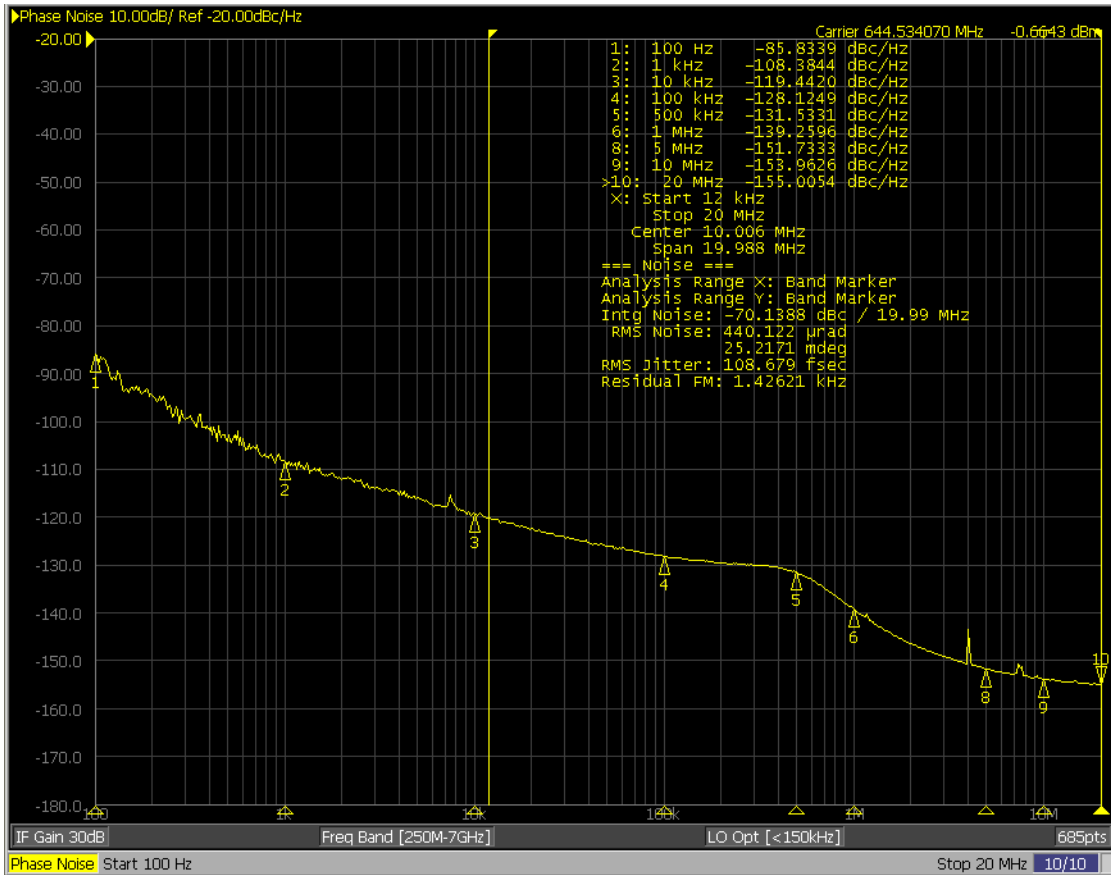
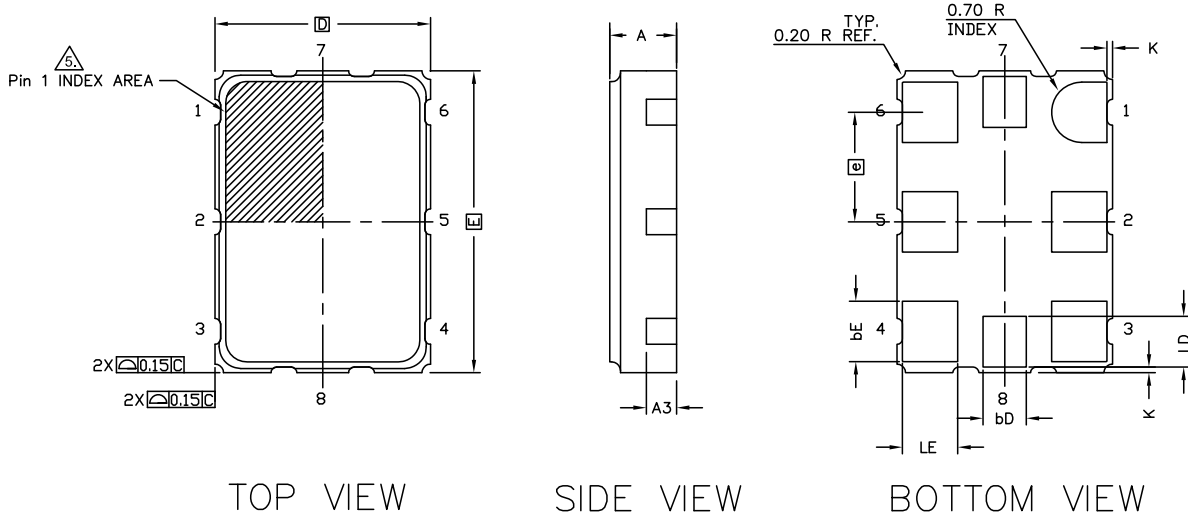

Figure 16. Typical Phase Noise at 644.53 MHz (12 kHz–20 MHz)



Package Diagrams

Figure 17. 8-pin Ceramic LCC (5.0 × 7.0 × 1.75 mm) Package Outline, 002-10174



SYMBOL	DIMENSIONS		
	MIN.	NOM.	MAX.
A	1,65	-	1,75
A3	0,70 REF		
D	5,00 BSC		
E	7,00 BSC		
bD	1,00		
bE	1,40		
LD	1,18		
LE	1,28		
K	0,13		
e	2,54 BSC		
N	8		
ND	1		
NE	3		

NOTES:

1. ALL DIMENSIONS ARE IN MILLIMETERS.
2. N IS THE TOTAL NUMBER OF TERMINALS.
3. ND IS THE NUMBER OF TERMINALS ON "D" DIMENSION.
4. NE IS THE NUMBER OF TERMINALS ON "E" DIMENSION.
5. PIN #1 ID ON TOP WILL BE LOCATED WITHIN THE INDICATED ZONE.

002-10174 *A

Figure 18. 8-pin Ceramic LCC (3.2 × 5.0 × 1.45 mm) Package Outline, 002-10273

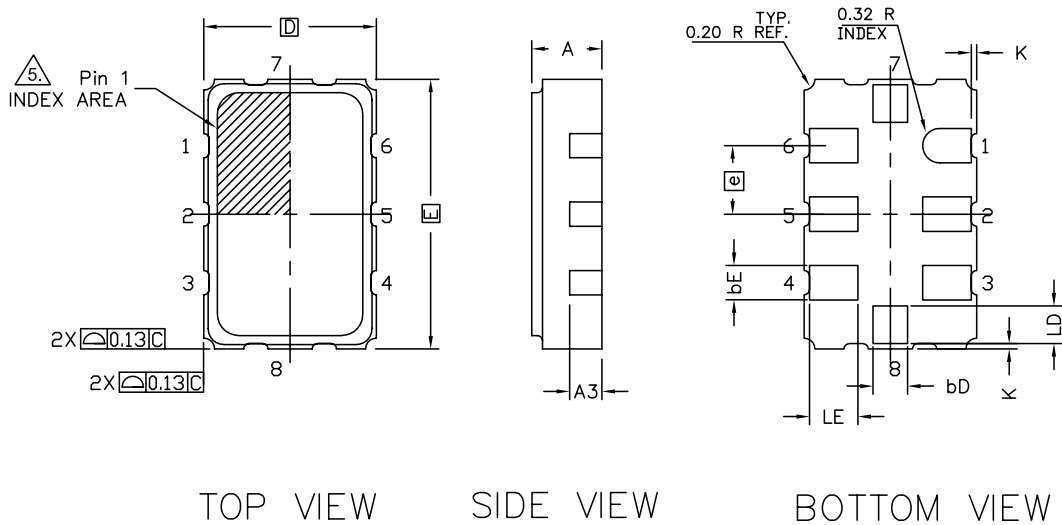

SYMBOL	DIMENSIONS		
	MIN.	NOM.	MAX.
A	1.35	-	1.45
A3	0.60 REF		
D	3.20 BSC		
E	5.00 BSC		
bD	0.64		
bE	0.64		
LD	0.70		
LE	0.90		
K	0.10		
e	1.27 BSC		
N	8		
ND	1		
NE	3		

NOTES:

1. ALL DIMENSIONS ARE IN MILLIMETERS.
 2. N IS THE TOTAL NUMBER OF TERMINALS.
 3. ND IS THE NUMBER OF TERMINALS ON "D" DIMENSION.
 4. NE IS THE NUMBER OF TERMINALS ON "E" DIMENSION.
5. PIN #1 ID ON TOP WILL BE LOCATED WITHIN THE INDICATED ZONE.

002-10273 *A

Acronyms

Table 5. Acronyms Used in this Document

Acronym	Description
AC	alternating current
ADC	analog-to-digital converter
BCL	best-fit straight line
CML	current mode logic
DC	direct current
ESD	electrostatic discharge
FS	frequency select
HCSL	high-speed current steering logic
I ² C	inter-integrated circuit
JEDEC	Joint Electron Device Engineering Council
LDO	low dropout (regulator)
LVC MOS	low voltage complementary metal oxide semiconductor
LVDS	low-voltage differential signals
LVPECL	low-voltage positive emitter-coupled logic
NVM	non-volatile memory
OE	output enable
PLL	phase-locked loop
POR	power-on reset
PSoC [®]	Programmable System-on-Chip
QFN	quad flat no-lead
RMS	root mean square
SCL	serial I ² C clock
SDA	serial I ² C data
VCXO	voltage controlled crystal oscillator
VRB	voltage ring back
XTAL	crystal
OTP	one time programmable

Document Conventions

Units of Measure

Table 6. Units of Measure

Symbol	Unit of Measure
°C	Degrees Celsius
fs	femtoseconds
GHz	gigahertz
kΩ	kilohms
kHz	kilohertz
MHz	megahertz
MΩ	megaohms
μA	microamperes
μm	micrometer
μs	microseconds
μW	microwatts
mA	milliamperes
mm	millimeter
mΩ	milliohms
ms	milliseconds
mV	millivolts
nH	nanohenry
ns	nanoseconds
Ω	ohms
%	percent
pF	picofarads
ps	picoseconds
ppm	parts per million
ppb	parts per billion
V	volts

Document History Page

Document Title: CY2941x/CY2942x, High-Performance Programmable Oscillators				
Document Number: 001-97768				
Rev.	ECN No.	Orig. of Change	Submission Date	Description of Change
*C	5320399	MGPL	07/18/2016	Changed status from Preliminary to Final.
*D	5429121	MGPL	09/07/2016	Updated Absolute Maximum Ratings : Added "Supply Current for eFuse Programming". Replaced "≥ 2000 V" with "2000 V" in value corresponding to "ESD HBM". Replaced "> 200 V" with "200 V" in value corresponding to "ESD MM". Replaced ">500V" with "400 V" in value corresponding to "ESD CDM". Updated to new template.
*E	5518357	MGPL / PSR	11/15/2016	Updated Voltage and Timing Definitions : Added Figure 8 .
*F	5613574	PSR	02/03/2017	Updated Functional Description : Updated description. Added "For a complete list of related documentation, click here ." at the end. Updated DC Electrical Specifications : Updated details in "Test Conditions" columns corresponding to I _{DD} parameter having description "Supply current, LVPECL". Updated AC Electrical Specifications for LVPECL, LVDS, CML Outputs : Added note below heading (clarifying voltage range). Updated Ordering Information : Updated part numbers.
*G	5682054	PSR	04/03/2017	Replaced V _{DDO} with V _{DD} in all instances across the document. Updated to new template.
*H	5757596	PSR	05/31/2017	Updated VCXO Specific Parameters : Updated details in all columns corresponding to V _{CTYP} parameter. Updated to new template.
*I	6178001	XHT	05/31/2018	Updated Voltage and Timing Definitions : Updated Figure 5 . Updated Functional Overview : Updated Small/Large Change : Updated description. Updated I2C Interface : Updated description. Updated to new template.
*J	6372083	XHT	10/31/2018	Updated Functional Overview : Updated Small/Large Change : Updated description.

Sales, Solutions, and Legal Information

Worldwide Sales and Design Support

Cypress maintains a worldwide network of offices, solution centers, manufacturer's representatives, and distributors. To find the office closest to you, visit us at [Cypress Locations](#).

Products

Arm [®] Cortex [®] Microcontrollers	cypress.com/arm
Automotive	cypress.com/automotive
Clocks & Buffers	cypress.com/clocks
Interface	cypress.com/interface
Internet of Things	cypress.com/iot
Memory	cypress.com/memory
Microcontrollers	cypress.com/mcu
PSoC	cypress.com/psoc
Power Management ICs	cypress.com/pmic
Touch Sensing	cypress.com/touch
USB Controllers	cypress.com/usb
Wireless Connectivity	cypress.com/wireless

PSoC[®] Solutions

[PSoC 1](#) | [PSoC 3](#) | [PSoC 4](#) | [PSoC 5LP](#) | [PSoC 6 MCU](#)

Cypress Developer Community

[Community](#) | [Projects](#) | [Video](#) | [Blogs](#) | [Training](#) | [Components](#)

Technical Support

cypress.com/support

© Cypress Semiconductor Corporation, 2015–2018. This document is the property of Cypress Semiconductor Corporation and its subsidiaries, including Spansion LLC ("Cypress"). This document, including any software or firmware included or referenced in this document ("Software"), is owned by Cypress under the intellectual property laws and treaties of the United States and other countries worldwide. Cypress reserves all rights under such laws and treaties and does not, except as specifically stated in this paragraph, grant any license under its patents, copyrights, trademarks, or other intellectual property rights. If the Software is not accompanied by a license agreement and you do not otherwise have a written agreement with Cypress governing the use of the Software, then Cypress hereby grants you a personal, non-exclusive, nontransferable license (without the right to sublicense) (1) under its copyright rights in the Software (a) for Software provided in source code form, to modify and reproduce the Software solely for use with Cypress hardware products, only internally within your organization, and (b) to distribute the Software in binary code form externally to end users (either directly or indirectly through resellers and distributors), solely for use on Cypress hardware product units, and (2) under those claims of Cypress's patents that are infringed by the Software (as provided by Cypress, unmodified) to make, use, distribute, and import the Software solely for use with Cypress hardware products. Any other use, reproduction, modification, translation, or compilation of the Software is prohibited.

TO THE EXTENT PERMITTED BY APPLICABLE LAW, CYPRESS MAKES NO WARRANTY OF ANY KIND, EXPRESS OR IMPLIED, WITH REGARD TO THIS DOCUMENT OR ANY SOFTWARE OR ACCOMPANYING HARDWARE, INCLUDING, BUT NOT LIMITED TO, THE IMPLIED WARRANTIES OF MERCHANTABILITY AND FITNESS FOR A PARTICULAR PURPOSE. No computing device can be absolutely secure. Therefore, despite security measures implemented in Cypress hardware or software products, Cypress does not assume any liability arising out of any security breach, such as unauthorized access to or use of a Cypress product. In addition, the products described in these materials may contain design defects or errors known as errata which may cause the product to deviate from published specifications. To the extent permitted by applicable law, Cypress reserves the right to make changes to this document without further notice. Cypress does not assume any liability arising out of the application or use of any product or circuit described in this document. Any information provided in this document, including any sample design information or programming code, is provided only for reference purposes. It is the responsibility of the user of this document to properly design, program, and test the functionality and safety of any application made of this information and any resulting product. Cypress products are not designed, intended, or authorized for use as critical components in systems designed or intended for the operation of weapons, weapons systems, nuclear installations, life-support devices or systems, other medical devices or systems (including resuscitation equipment and surgical implants), pollution control or hazardous substances management, or other uses where the failure of the device or system could cause personal injury, death, or property damage ("Unintended Uses"). A critical component is any component of a device or system whose failure to perform can be reasonably expected to cause the failure of the device or system, or to affect its safety or effectiveness. Cypress is not liable, in whole or in part, and you shall and hereby do release Cypress from any claim, damage, or other liability arising from or related to all Unintended Uses of Cypress products. You shall indemnify and hold Cypress harmless from and against all claims, costs, damages, and other liabilities, including claims for personal injury or death, arising from or related to any Unintended Uses of Cypress products.

Cypress, the Cypress logo, Spansion, the Spansion logo, and combinations thereof, WICED, PSoC, CapSense, EZ-USB, F-RAM, and Traveo are trademarks or registered trademarks of Cypress in the United States and other countries. For a more complete list of Cypress trademarks, visit cypress.com. Other names and brands may be claimed as property of their respective owners.

Looking for pricing, stock, or lifecycle information?

Click below to explore more details on WIN SOURCE:

 [View CY29411LXI001](#) on WIN SOURCE

 [Infineon Technologies](#) Information

Optimize Your Supply Chain with WIN SOURCE Solutions

-  Global Sourcing Solution
-  Obsolete Management
-  Cost Control Management
-  Shortage Management
-  Alternative Solution
-  Excess Inventory Management