



**THE DATASHEET OF  
ASEK712ELC-05B-T-DK**





**Rev OI to Rev A Changes:**

1. Not documented.

**How to convert Rev OI to Rev A:**

1. Not possible.

**Rev A to Rev B Changes:**

1. This update was to change TED paperwork to latest standards.
2. No PCB or schematic changes.
3. REV, ASY, OPT, TOP pages added.
4. The BOM for the board, minus sensor, moved to -001 (from -000).  
This was done to fit into the "no -000 assembly" method of multiple build option demo boards.

**How to convert Rev A to Rev B:**

1. No changes necessary.

**Rev B to Rev C Changes:**

1. Assembly Instructions fixed:  
Step 5 had RJ installed as 0.125" and 0.25" in error.  
Changed to be 0.125" installation height.
2. No other changes.

**How to convert Rev B to Rev C:**

1. No changes necessary.

1. RoHS Compliance Required?  
**Yes.**  
**All components and assembly practices must be RoHS Compliant.**  
**Certificates of RoHS compliance must be sent to Allegro for record keeping.**
  
2. Other TED Packs and/or outside Specifications required for build:  
none required.
  
3. Are there optional ways to build this TED pack?  
Yes.  
Please read 85-0322-000-OPT for build options.
  
4. Pages with the descriptor "-ASY" are expected to be followed by the assembly person / assembly house. These are the Construction Notes / Assembly Notes pages, and are used to convey building instructions.
  
5. The notes on the -TST pages are expected to be followed by Allegro; product shall not be sold to customers until the steps on the -TST pages are completed. These are test and verification steps, and are used to test assembly(s) prior to usage and/or selling.  
They are not "calibration" procedures as used on production equipment.
  
6. All photos provided are for reference only; slight variations may result from component second sourcing or later design changes. Photos are intended to convey roughly what completed assembly should look like.
  
7. As multiple boards exist under this TED pack number (85-0322), there is no -000 assembly.
  
8. All boards use the -000-ASY Assembly Instructions.

There are several different assemblies listed under this TED pack.  
Build according to Request Number / Option Number / Description / TBD,  
as explained below:

#	Request:	Build (1) each of these:	Description:
1	ACS712ELC-05B-T	85-0322-010	ACS712ELC-05B-T
	85-0322-010	85-0322-010	ACS712ELC-05B-T
2	ACS712ELC-20A-T	85-0322-011	ACS712ELC-20A-T
	85-0322-011	85-0322-011	ACS712ELC-20A-T
3	ACS712ELC-30A-T	85-0322-012	ACS712ELC-30A-T
	85-0322-012	85-0322-012	ACS712ELC-30A-T
4	ACS713ELC-20A-T	85-0322-013	ACS713ELC-20A-T
	85-0322-013	85-0322-013	ACS713ELC-20A-T
5	ACS713ELC-30A-T	85-0322-014	ACS713ELC-30A-T
	85-0322-014	85-0322-014	ACS713ELC-30A-T

All boards must be labeled after construction (see -000-ASY)

1. These boards do not require testing prior to shipping to customers.

Originator: Shawn Upton

1. All 85-0322 assemblies require a sticker to be applied post-construction. This sticker shall be applied by whomever constructs the boards. This sticker shall be as such:

#	Allegro Part:	Label
1	85-0322-010 ACS712ELC-05B-T	ASEK712ELC-05B-T
2	85-0322-011 ACS712ELC-20A-T	ASEK712ELC-20A-T
3	85-0322-012 ACS712ELC-30A-T	ASEK712ELC-30A-T
4	85-0322-013 ACS713ELC-20A-T	ASEK713ELC-20A-T
5	85-0322-014 ACS713ELC-30A-T	ASEK713ELC-30A-T

2. This sticker may be applied onto the top of the board, if it can be. If the sticker is topside, it shall be located between U1 and the silkscreen text "Current Sensor". This is if it will fit, without overlaying any silkscreen text or solderpads. If the sticker is larger than that area, the sticker shall be located on the backside of the PCB.
3. Any sticker applied by the assembly house (not of the type above) shall be installed on the backside of the pcb. [This may be a tracking number, or the assembly house P/N.] The label shall not cover any holes used for soldering.
4. The Allegro sensor may be installed at any time. That is, all the parts required to build an 85-0322-010 (for example) may be installed at the same time.
5. RJ: 22g jumper. Use 22g buss wire, 0.5 inch body, with 0.25 inch leads bent 90 degree. Install 0.125 inch above PCB (not critical). Solder and trim. This component will be used for scope ground clips.

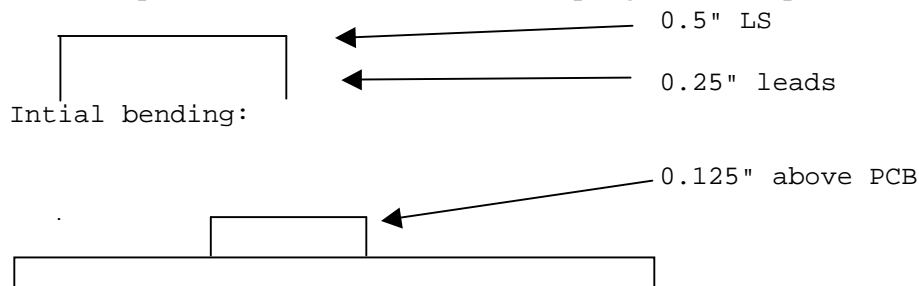

6. It is recommended that the SMT parts be installed first, then thro-hole, then banana jacks and standoffs, lastly the sticker(s). Any order of operations may be performed, however.

All components and assembly practices must be RoHS Compliant  
Certificates of RoHS compliance must be sent to Allegro for record keeping

To Install RJ: use buss wire, approx 22-24g. Bend a 1 inch length to 0.5 inch lead spacing,  
just like as if forming leads for a conventional resistor.  
Install approximately 0.25 inch above the PCB.  
This jumper is scope ground clips and must have ample space under it!

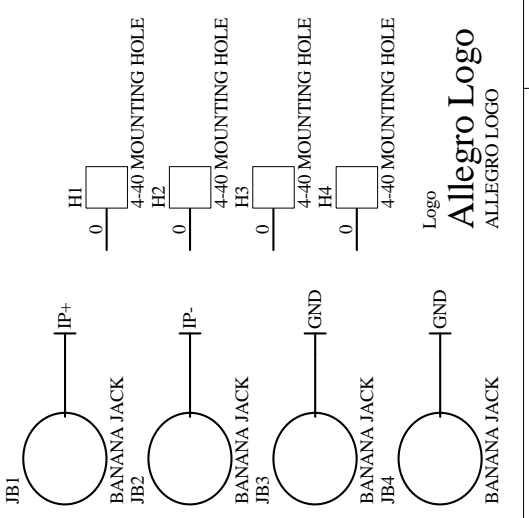
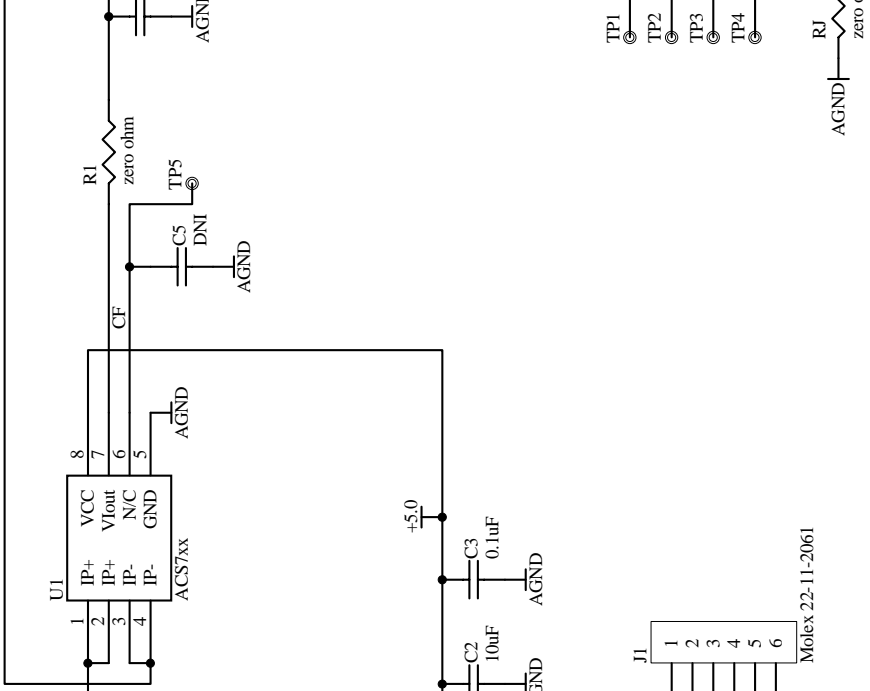

TP1 - TP4: Testpoints for 0.063 h  
 JB1 - JB4: use Johnson Compone  
 C1, C2: 1206 16V 10uF; Panason  
 C3: 0603 16V 0.1uF; Panasoni E  
 L1: 0603 Murata BLM188B471S  
 R1: 0603 zero ohm; Panasoni E  
 RJ: Use buss wire, 0.5inch long a

RoHS/Pb-free Label

Title ACS7xx Demo Board	
Size: A	Number: 85-0322-000-SCH
Date: 9/21/2006	Time: 2:29:13 PM   Sheet 1 of 1
File: C:\Documents and Settings\supton\My Documents\DXP	

A

B

C

D

ACS7xx Demo Board  
85-0322-000-BD1

PCB Outline  
Page 1 of 1  
FR4, 0.062, 2 Layers  
4oz Finished Copper top/bottom  
No Gold Plating  
Top/bottom side silkscreen  
Top/bottom soldermask

SCALE: 1.48

9/21/2006

Min trace = 10mil, min trace spacing = 10mils, min hole size 15mil

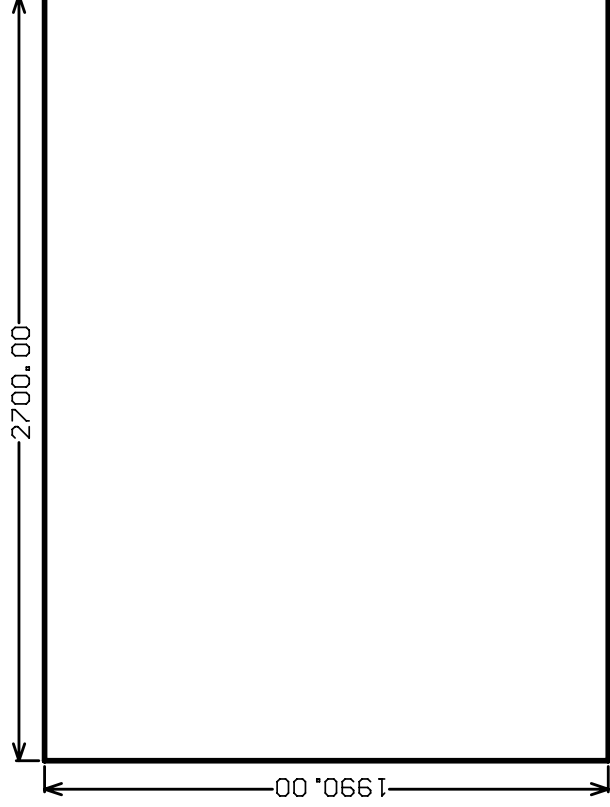

ACS7xx Demo Board  
85-0322-000-SS1

Silkscreen Component Side  
Page 1 of 1  
FR4, 0.062, 2 Layers  
4oz Finished Copper top/bottom  
No Gold Plating  
Top/bottom side silkscreen  
Top/bottom soldermask

SCALE: 1.48

9/21/2006

Min trace = 10mil, min trace spacing = 10mils, min hole size 15mil

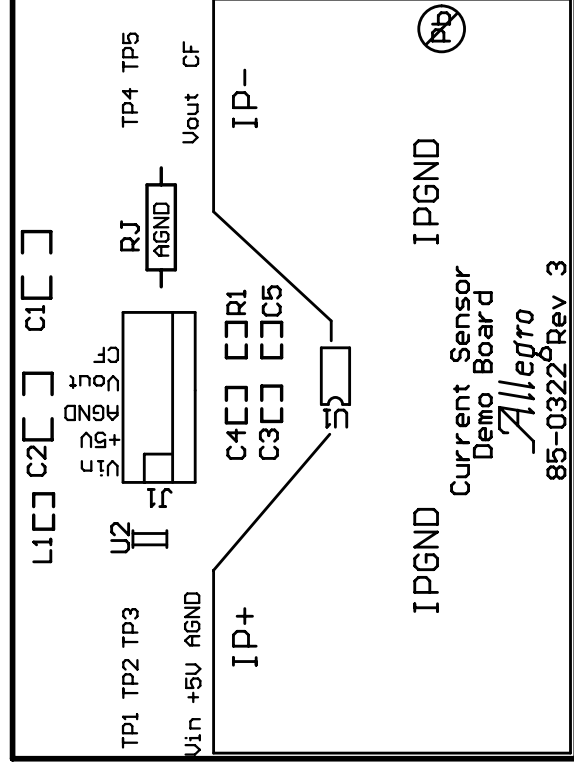

ACS7xx Demo Board  
85-0322-000- SM1

Top Soldermask  
Page 1 of 1  
FR4, 0.062, 2 Layers  
4oz Finished Copper top/bottom  
No Gold Plating  
Top/bottom side silkscreen  
Top/bottom soldermask

SCALE: 1.48

9/21/2006

Min trace = 10mil, min trace spacing = 10mils, min hole size 15mil

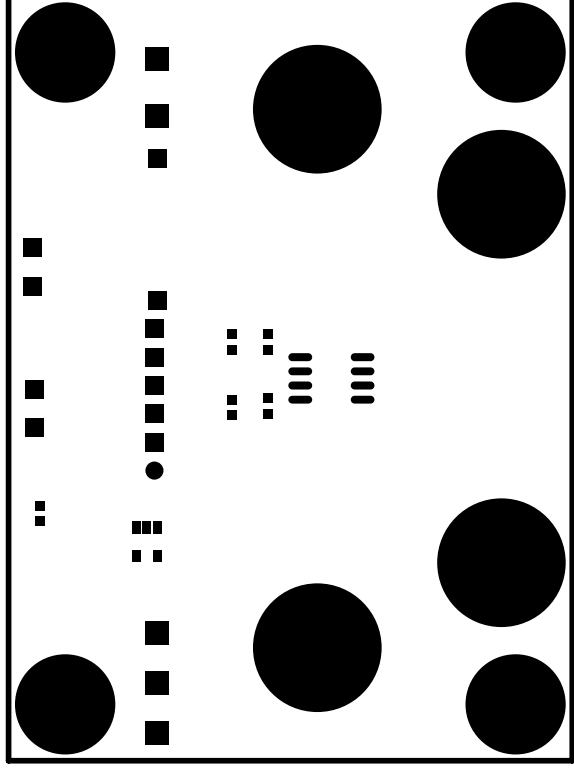

ACS7xx Demo Board  
85-0322-000-SM2

Bottom Soldermask  
Page 1 of 1  
FR4, 0.062, 2 Layers  
4oz Finished Copper top/bottom  
No Gold Plating  
Top/bottom side silkscreen  
Top/bottom soldermask

SCALE: 1.48

9/21/2006

Min trace = 10mil, min trace spacing = 10mils, min hole size 15mil

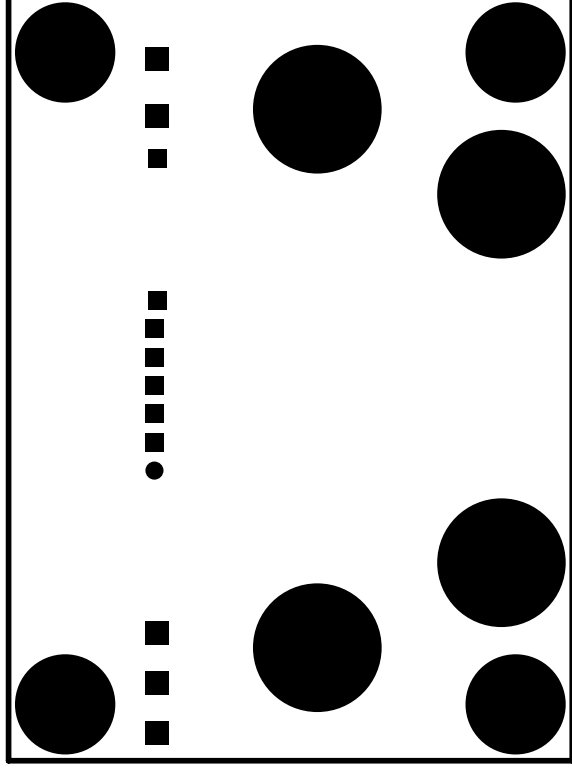

ACS7xx Demo Board  
85-0322-000- CU1

Copper Component Side  
Page 1 of 1  
FR4, 0.062, 2 Layers  
4oz Finished Copper top/bottom  
No Gold Plating  
Top/bottom side silkscreen  
Top/bottom soldermask

SCALE: 1.48

9/21/2006

Min trace = 10mil, min trace spacing = 10mils, min hole size 15mil

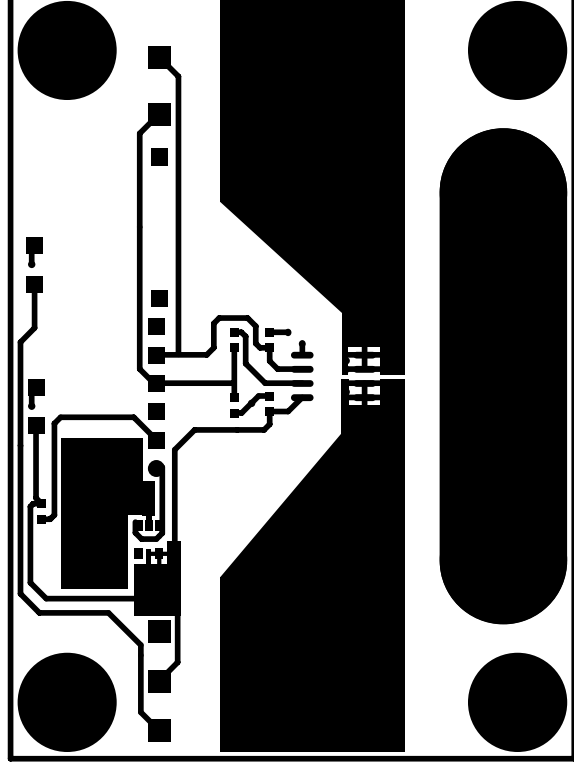

ACS7xx Demo Board  
85-0322-000-CU2

Copper Solder Side

Page 1 of 1

FR4, 0.062, 2 Layers

4oz Finished Copper top/bottom

No Gold Plating

Top/bottom side silkscreen

Top/bottom soldermask

SCALE: 1.48

9/21/2006

Min trace = 10mil, min trace spacing = 10mils, min hole size 15mil

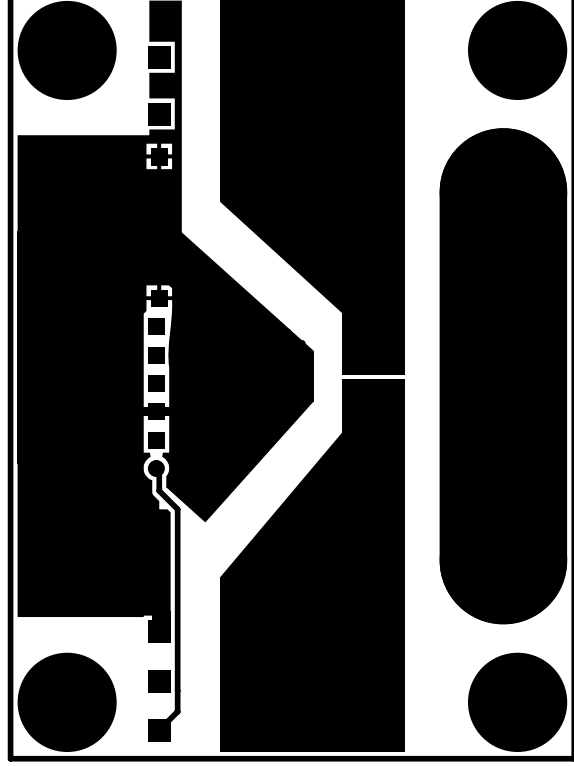

ACS7xx Demo Board  
85-0322-000-GG1

### Drill Guide

Page 1 of 1

FR4, 0.062, 2 Layers  
4oz Finished Copper top/bottom  
No Gold Plating  
Top/bottom side silkscreen  
Top/bottom soldermask

SCALE: 1.48

9/21/2006

Min trace = 10mil, min trace spacing = 10mils, min hole size 15mil

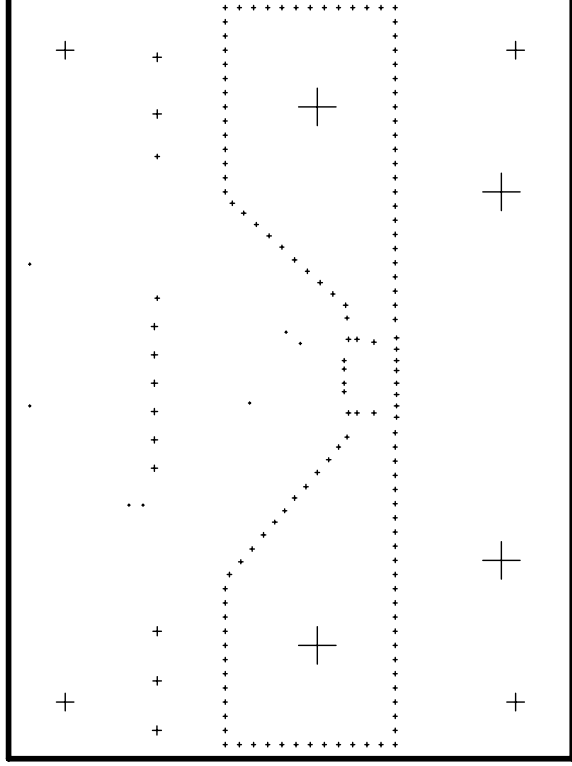

ACS7xx Demo Board  
85-0322-000-GD1

Drill Drawing  
Page 1 of 1  
FR4, 0.062, 2 Layers  
4oz Finished Copper top/bottom  
No Gold Plating  
Top/bottom side silkscreen  
Top/bottom soldermask

SCALE: 1.48

9/21/2006

Min trace = 10mil, min trace spacing = 10mils, min hole size 15mil

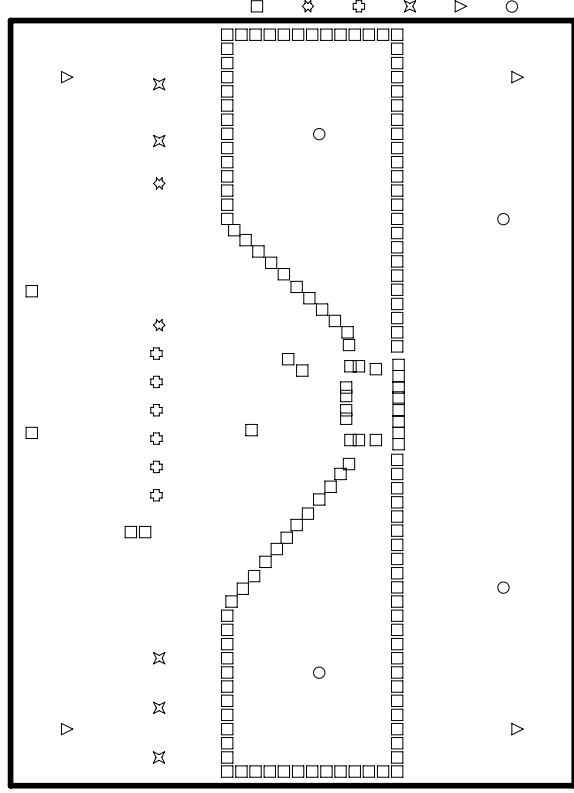

142  
2  
6  
5  
4  
4  
163

15m  
32m  
42m  
62m  
125  
266  
Totc

Originator: Shawn Upton

ITEM	QTY	S	Manufacturer	P/N	DESCRIPTION
1	2	6	Panasonic	ECJ-HVB1C106M	capacitor, monolythic, 1206, X5R, 10uF, 16V
2	1	6	Panasonic	ECJ-1VB1C104K	capacitor, monolythic, 0603, X5R, 0.1uF, 16V
3					Do Not Install
4	1	6	Panasonic	ERJ-3GEY0R00V	resistor, metal film, 0603, 5%, zero ohm
5	1	6	Murata	BLM18BB471SN1D	inductor, 0603
6	1	10	National Semi	LP2980AIM5-5.0	IC, voltage regulator, 5V, SOT-23-5
7	4	10	Johnson Components	111-2223-001	connector, banana plug
8	5	10	Keystone Electronics	5005K	testpoint, 0.063 inch diameter, red
9	4				screw, zinc metal plated, 4-40, 0.5 inch, Phillips
10	4	6	Keystone Electronics	1450C	standoff, male/male, zinc metal plated, 4-40, 0.5 inch long, hex shaped
11	1	10	Molex	22-11-2062	connector, friction lock header, 6 pin
12	1				buss wire, tinned, 22 or 24 gauge
13	1	10			0.5 inch long. See construction notes
					PCB, as from gerber files
					marked "85-0322"
14	1	10	Allegro	Current Sensor	IC, SOIC8, as provided by Allegro

All components and assembly practices must be RoHS Compliant  
 Certificates of RoHS compliance must be sent to Allegro for record keeping;

**Originator: Shawn Upton**

**BOM Explanation**

Item: each distinct component has a "line item" (but may span multiple lines). When questions arise to a component parameter/dimension refer to line item number first when inquiring.

QTY: the quantity of items to be ordered per finished assembly. Note: higher level documents may call this BOM multiple times

S: BOM Substitution Instructions. See below  
Manufacturer: Recommended (or required) Manufacturer for the part(s). Note: multiple manufacturers may be listed per line item  
Note: if no manufacturer part number is given, the the item is considered generic enough that that any manufacturer should be acceptable

P/N: The manufacturers part number. Note: if multiple manufacturers are listed, this P/N will correspond only to the manufacturer of the P/N

Note: Manufacturer part number may be incomplete; if not enough information is given, see below.

Description: this is a generic description of the part. Package size, part type, minimum/maximum requirements are listed.  
Note: this is generic and may not exactly reflect the suggested/required part. For example, "capacitor, 25V" while the manufacturer is actually 50V. The capacitor is required to a minimum of 25V rated (important only if second sourcing)

Ref: This is the list of component designators.

If "see construction notes" is listed, the construction notes must be used to determine component location (not marked on drawing)  
Note: surface mount components may have a designator listed but not marked on PCB silkscreen; if so then refer to -CP for location and/or the pick and place file (as found in the gerber files)

If a line item has multiple part numbers, they are not to be interpreted as any order of preference

If a line item has multiple part numbers, and the substitution code is 10, then only use parts as listed.

Mixing is allowed (for example, if 2 manufacturers are listed, and qty is 5, then 2 parts may be from vendor A and 3 parts from vendor B)

**BOM Substitution Notes:**

The third column nomenclature is to be used for second sourcing components as follows:

1. Any substitution allowed, as long as mechanically identical (non-electrical items only) (visually different ok)
2. Any substitution allowed, as long as mechanically similar (non-electrical items only) (visually different ok)
3. Any substitution, as long as mechanically and visually identical (non-electrical items only)
4. Any substitution allowed, as long as mechanically and visually similar (non-electrical items only)
5. Any substitution allowed, as long as mechanically and visually identical and electrically similar
6. Any substitution allowed, as long as mechanically, electrically and visually similar
7. Reserved for future usage.
8. Reserved for future usage
9. Substitution not recommended, but allowed if mechanically, electrically and visually similar. Only substitute if no alternative.
10. No substitution allowed.

**"Identical"** is to be interpreted as "meeting the same specifications" with no deviation from the specifications.

If no manufacturer is given, then do not deviate from stated specifications in the Description field.

If a manufacturer is given, do not deviate from the specifications from the manufacturer--the Description field is for reference only  
**"Similar"** is to be interpreted as "meeting or exceeding the stated specifications, in regards to electrical and/or mechanical parameters (see Substitution code).

**Originator: Shawn Upton**

If no manufacturer is given, then do not deviate from stated specifications in the Description field.

If a manufacturer is given, do not deviate from the specifications from the manufacturer--the Description field is for reference. "Similar" as applied to visual means different colors may be used, unless otherwise noted. For example, an item with Substituted typically be any color.

However, if the description states "red" and the substitution code is 4, 6 or similar, then a red item must be used--but it may. For example, if a capacitor is to be "identical", it must have the same voltage and tempco etc ratings as stated in the description. If a capacitor is to be similar, the voltage rating may be higher, the tempco lower, etc.

Unless if the Substitution code is 10, "identical" parts may be sourced from different manufacturers and may have slight. These subtle differences are ok.

**Substituting for "Similar" parts:**

Capacitors:

- tempco must be same or go down. Alternately, go up in this order: Z5U, X5R, X7R, NP0, C0G
- tolerance must be same or go down
- voltage rating must be same or go up
- unless otherwise stated, capacitance value must be identical
- unless otherwise stated, lead spacing must be same; external dimensions must be the same or smaller

Resistors:

- tempco must same or go down
  - tolerance must be same or go down
  - unless otherwise stated, resistance value must be identical
- Note: when going from 5% to 1%, use nearest value size
- power dissipation must be same or greater
  - unless otherwise stated, package size must be the same
  - unless otherwise stated, coloring and marking can vary

Diodes and Transistors:

- unless otherwise stated, package size must be the same

IC's, Connectors, and all other parts::

- unless otherwise stated, package size must be the same (DIP16, SOIC-8, etc)

**Manufacturer Part Number Discrepancies**

Every attempt will be made to provide a workable part number. However, prefixes and suffixes can vary over time.

If second sourcing from a different manufacturer, make sure that the requirements as noted under the Description column are met. In general, if temperature option(s) are not noted, parts specified to work from 0-85C will be sufficient.

If package information is not given, please check the manufacturer datasheet for package type.

**Any and all discrepancies should be reported to Allegro MicroSystems for correction and updates.**

**ACS7xx Demo Board**

**85-0322-010-BOM**

**Originator: Shawn Upton**

**Bill of Materials**

**Page 1 of 1**

<b>ITEM</b>	<b>QTY</b>	<b>S</b>	<b>Manufacturer</b>	<b>P/N</b>	<b>DESCRIPTION</b>
1	1	10	Allegro	85-0322-001	board
2	1	10	Allegro	ACS712ELC-05B-T	IC, SOIC8, current sensor

All components and assembly practices must be RoHS Compliant  
Certificates of RoHS compliance must be sent to Allegro for record keeping

**ACS7xx Demo Board**

**85-0322-011-BOM**

**Originator: Shawn Upton**

**Bill of Materials**

**Page 1 of 1**

<b>ITEM</b>	<b>QTY</b>	<b>S</b>	<b>Manufacturer</b>	<b>P/N</b>	<b>DESCRIPTION</b>
1	1	10	Allegro	85-0322-001	board
2	1	10	Allegro	ACS712ELC-20A-T	IC, SOIC8, current sensor

All components and assembly practices must be RoHS Compliant  
Certificates of RoHS compliance must be sent to Allegro for record keeping

Originator: Shawn Upton

ITEM	QTY	S	Manufacturer	P/N	DESCRIPTION
1	1	10	Allegro	85-0322-001	board
2	1	10	Allegro	ACS712ELC-30A-T	IC, SOIC8, current sensor

All components and assembly practices must be RoHS Compliant  
 Certificates of RoHS compliance must be sent to Allegro for record keeping

**ACS7xx Demo Board**

**85-0322-013-BOM**

**Originator: Shawn Upton**

**Bill of Materials**

**Page 1 of 1**

<b>ITEM</b>	<b>QTY</b>	<b>S</b>	<b>Manufacturer</b>	<b>P/N</b>	<b>DESCRIPTION</b>
1	1	10	Allegro	85-0322-001	board
2	1	10	Allegro	ACS713ELC-20A-T	IC, SOIC8, current sensor

All components and assembly practices must be RoHS Compliant  
Certificates of RoHS compliance must be sent to Allegro for record keeping

Originator: Shawn Upton

ITEM	QTY	S	Manufacturer	P/N	DESCRIPTION
1	1	10	Allegro	85-0322-001	board
2	1	10	Allegro	ACS713ELC-30A-T	IC, SOIC8, current sensor

All components and assembly practices must be RoHS Compliant  
Certificates of RoHS compliance must be sent to Allegro for record keeping

## Looking for pricing, stock, or lifecycle information?

Click below to explore more details on WIN SOURCE:

- ⊖ [View ASEK712ELC-05B-T-DK on WIN SOURCE](#)
- ⊖ [Allegro MicroSystems, LLC Information](#)

## Optimize Your Supply Chain with WIN SOURCE Solutions

- ✓ Global Sourcing Solution
- ✓ Obsolete Management
- ✓ Cost Control Management
- ✓ Shortage Management
- ✓ Alternative Solution
- ✓ Excess Inventory Management