



**THE DATASHEET OF  
A5950KEUSR-J**



## DC Motor Driver

### FEATURES AND BENEFITS

- Overcurrent protection (OCP)
- Motor lead short-to-ground protection
- Motor lead short-to-battery protection
- Motor short protection
- Low-power standby mode
- Fault output
- Adjustable current limit option
- Current-to-voltage output
- Synchronous rectification – high-side
- Internal UVLO
- Crossover-current protection
- Thermal warning and shutdown function
- AEC-Q100 Grade 0 qualified – K version

### DESCRIPTION

Designed for pulse-width-modulated (PWM) control of DC motors, the A5950 is capable of peak output currents up to  $\pm 3$  A and operating voltages up to 40 V.

Input terminals are provided for use in controlling the speed and direction of a DC motor with externally applied PWM control signals. Internal synchronous rectification control circuitry is provided to lower power dissipation during PWM operation.

Internal circuit protection includes overcurrent protection, motor lead short to ground or supply, thermal shutdown with hysteresis, undervoltage monitoring of VBB, and crossover-current protection.

The A5950 is supplied in a low-profile 4 mm  $\times$  4 mm 16-contact QFN (suffix “EU”) package with wettable flank option (suffix “-P”), or a 16-lead eTSSOP (suffix “LP”), all three with exposed power tab for enhanced thermal performance.

### PACKAGES:

*Not to scale*

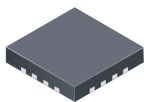

16-lead QFN  
with exposed thermal pad  
(suffix EU, option -T)

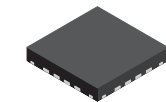
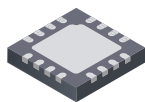

16-lead QFN  
with exposed thermal pad  
and wettable flank (suffix EU, option -P)

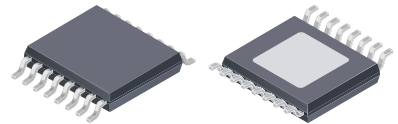
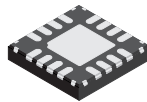

16-lead TSSOP  
with exposed thermal pad  
(suffix LP)

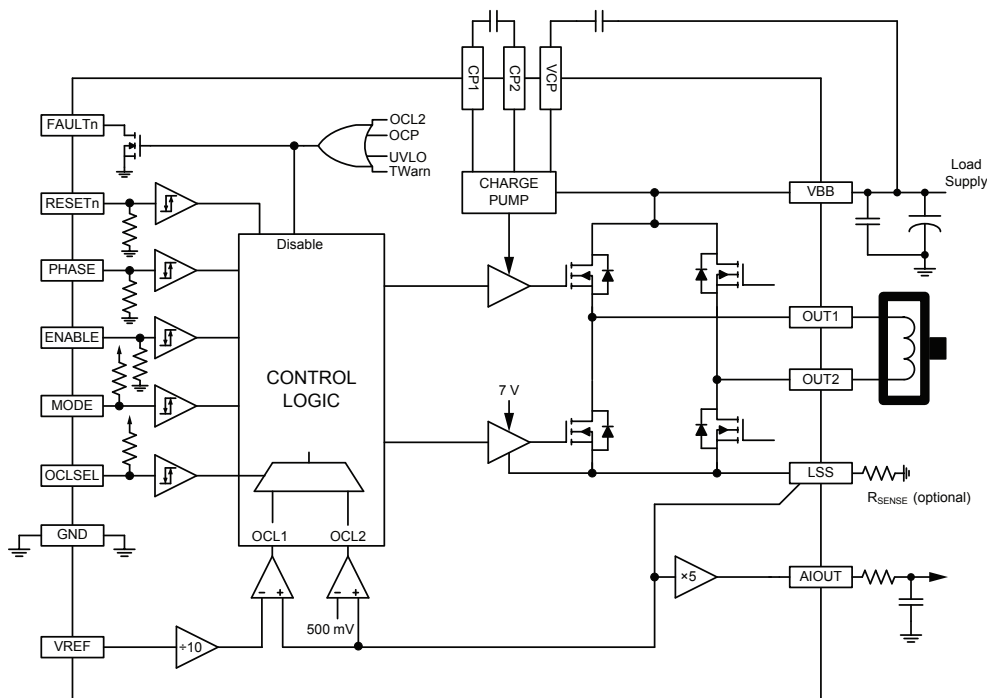

**Figure 1: Functional Block Diagram**

## SPECIFICATIONS

## SELECTION GUIDE

Part Number	Operating Ambient Temperature Range $T_A$ (°C)	Packaging	Packing
A5950GEUSR-T	-40 to 105	16-lead QFN with exposed pad	6000 pieces per 13-in. reel
A5950GLPTR-T	-40 to 105	16-lead TSSOP with exposed pad	4000 pieces per 13-in. reel
A5950KEUSR-J	-40 to 150	16-lead QFN with exposed pad and wettable flank	6000 pieces per 13-in. reel
A5950KLPTR-T	-40 to 150	16-lead TSSOP with exposed pad	4000 pieces per 13-in. reel

## ABSOLUTE MAXIMUM RATINGS

Characteristic	Symbol	Notes	Rating	Unit
Load Supply Voltage	$V_{BB}$		40	V
Motor Outputs	$V_{OUT}$		-2 to 42	V
LSS	$V_{LSS}$		±0.5	V
		$t_w < 200$ ns	±2.5	V
Output Current	$I_{OUT}$	Continuous [1]	3	A
Transient Output Current	$I_{OUTPK}$	$t_w < 500$ ns	internally limited	A
VREF	$V_{REF}$		-0.3 to 6	V
Logic Input Voltage Range	$V_{IN}$		-0.3 to 6	V
Junction Temperature	$T_J$		150	°C
Storage Temperature Range	$T_{stg}$		-55 to 150	°C
Operating Temperature Range	$T_A$	Range G	-40 to 105	°C
		Range K; limited by power dissipation	-40 to 150	°C

[1] Power dissipation and thermal limits must be observed.

## THERMAL CHARACTERISTICS: May require derating at maximum conditions; see application information

Characteristic	Symbol	Test Conditions [2]		Value	Unit
Package Thermal Resistance	$R_{\theta JA}$	16-lead TSSOP (suffix LP)	JEDEC Hi-K board	34	°C/W
			2 layer PCB, 1-in. <sup>2</sup> copper	51	°C/W
		16-lead QFN (suffix EU)	JEDEC Hi-K board	36	°C/W
			2 layer PCB, 1-in. <sup>2</sup> copper	TBD	°C/W

[2] Additional thermal information available on the Allegro website.

## PINOUT DIAGRAMS AND TERMINAL LIST TABLE

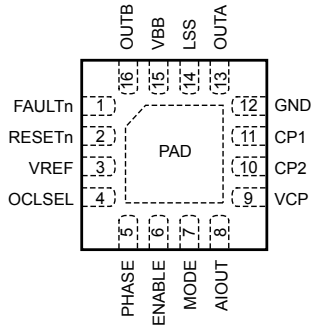

16-Lead QFN (EU) Package Pinout Diagram

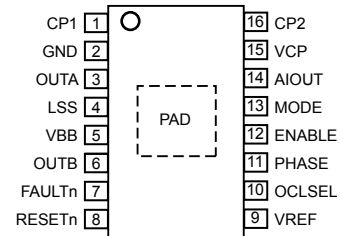

16-Lead TSSOP (LP) Package Pinout Diagram

### Terminal List Table

Name	Number		Function
	EU	LP	
AIOUT	8	14	Analog sense voltage output
CP1	11	1	Charge pump capacitor
CP2	10	16	Charge pump capacitor
ENABLE	6	12	Logic control input
FAULTn	1	7	Open drain logic output, active low
GND	12	2	Ground terminal
LSS	14	4	Sense voltage
MODE	7	13	Logic control input
OCLSEL	4	10	Logic control input
OUTA	13	3	Motor output
OUTB	16	6	Motor output
PHASE	5	11	Logic control input
RESETn	2	8	Logic control input, active low
VBB	15	5	Supply voltage
VCP	9	15	Charge pump capacitor
VREF	3	9	Analog input to set current limit
–	PAD	PAD	Exposed pad of the package providing enhanced thermal dissipation

**ELECTRICAL CHARACTERISTICS:**G Range Version: Valid at  $T_J = 25^\circ\text{C}$ ,  $V_{BB} = 5.5$  to  $40$  V (unless noted otherwise)K Range Version: Valid at  $T_J = -40^\circ\text{C}$  to  $150^\circ\text{C}$ ,  $V_{BB} = 5.5$  to  $40$  V (unless noted otherwise)

Characteristics	Symbol	Test Conditions	Min.	Typ.	Max.	Unit
<b>GENERAL</b>						
VBB Supply Current	$I_{BB}$	Outputs off or Brake mode	–	5.8	9	mA
	$I_{BB(\text{STANDBY})}$	Standby Mode, $T_J = 25^\circ\text{C}$	–	1	5	$\mu\text{A}$
		Standby Mode, $T_J = 150^\circ\text{C}$	–	10	25	$\mu\text{A}$
<b>OUTPUT DRIVERS</b>						
Source Driver On Resistance	$R_{\text{DSON}(\text{source})}$	$I = 3$ A, $T_J = 25^\circ\text{C}$ , $V_{BB} = 8$ V	–	335	–	m $\Omega$
		$I = 3$ A, $T_J = 150^\circ\text{C}$ , $V_{BB} = 8$ V	–	570	740	m $\Omega$
		$I = 3$ A, $T_J = 25^\circ\text{C}$ , $V_{BB} = 5.5$ V	–	370	–	m $\Omega$
		$I = 3$ A, $T_J = 150^\circ\text{C}$ , $V_{BB} = 5.5$ V	–	660	860	m $\Omega$
Sink Driver On Resistance	$R_{\text{DSON}(\text{sink})}$	$I = 3$ A, $T_J = 25^\circ\text{C}$ , $V_{BB} = 8$ V	–	365	–	m $\Omega$
		$I = 3$ A, $T_J = 150^\circ\text{C}$ , $V_{BB} = 8$ V	–	640	835	m $\Omega$
		$I = 3$ A, $T_J = 25^\circ\text{C}$ , $V_{BB} = 5.5$ V	–	390	–	m $\Omega$
		$I = 3$ A, $T_J = 150^\circ\text{C}$ , $V_{BB} = 5.5$ V	–	730	950	m $\Omega$
Body Diode Forward Voltage	$V_F$	$I = 3$ A	–	1.15	1.4	V
Output Rise time	$t_R$	$V_{BB} = 12$ V, 10% to 90%	50	100	200	ns
Output Fall Time	$t_F$	$V_{BB} = 12$ V, 90% to 10%	50	100	200	ns
Dead Time (Crossover)	$t_D$		–	350	550	ns
<b>LOGIC INPUT AND OUTPUT</b>						
Logic Output Voltage	$V_O$	$I = 2$ mA, fault asserted	–	0.2	0.5	V
Logic Output Leakage	$I_{\text{FLTn}}$	$V = 5$ V	–	–	5	$\mu\text{A}$
Logic Input Voltage	$V_{\text{IH}}$	PHASE, ENABLE, MODE, OCLSEL	2.0	–	5.5	V
	$V_{\text{IL}}$	PHASE, ENABLE, MODE, OCLSEL	0	–	0.8	V
	$V_{\text{IHRESETn}}$	RESETn	2.5	–	5.5	V
	$V_{\text{ILRESETn}}$	RESETn	0	–	0.4	V
Logic Input Hysteresis	$V_{\text{HYS}}$	PHASE, ENABLE, MODE, OCLSEL	200	355	500	mV
Logic Input Pull-Up Current	$I_{\text{PU}}$	OCLSEL, MODE; $V_{\text{IN}} = 0$ V	–20	–55	–90	$\mu\text{A}$
Logic Input Pull-Down Resistor	$R_{\text{PD}}$	RESETn, PHASE, ENABLE	25	50	80	k $\Omega$

[1] For input and output current specifications, negative current is defined as coming out of (sourcing) the specified device pin.

[2] For Range G devices, specified limits are tested at a single temperature and assured over operating temperature range by design and characterization.

**ELECTRICAL CHARACTERISTICS (continued):**G Range Version: Valid at  $T_J = 25^\circ\text{C}$ ,  $V_{BB} = 5.5$  to  $40\text{ V}$  (unless noted otherwise)K Range Version: Valid at  $T_J = -40^\circ\text{C}$  to  $150^\circ\text{C}$ ,  $V_{BB} = 5.5$  to  $40\text{ V}$  (unless noted otherwise)

Characteristics	Symbol	Test Conditions	Min.	Typ.	Max.	Unit
<b>PWM TIMING</b>						
Blank Time	$t_{BLK}$		2.7	3.2	3.7	$\mu\text{s}$
Fixed Off-time	$t_{OFF}$		22	25.5	29	$\mu\text{s}$
Percent Fast Decay	$P_{FD}$	Internal PWM chop	16	18	20	%
VREF Input Current	$I_{VREF}$		-5	<1	5	$\mu\text{A}$
VREF Input Range	$V_{REF}$		0	-	4.5	V
Current Sense Accuracy, External	$A_{VREV}$	$V_{REF} = 2\text{ V}, V_{REF}/V_{LSS}$	9.5	10	10.5	V/V
		$V_{REF} = 250\text{ mV}, V_{REF}/V_{LSS}$	8.4	10	11.6	V/V
SENSE Trip Level, Internal	$V_{TRIP}$	OCLSEL = low	450	500	550	mV
AIOUT Gain	$A_V$	$I = 200\ \mu\text{A}, V_{LSS} = 50$ to $200\text{ mV}$	4.3	5	5.7	V/V
		$I = 200\ \mu\text{A}, V_{LSS} = -50$ to $-200\text{ mV}$	-4.3	-5	-5.7	V/V
Power Up Delay	$t_{PU}$		-	250	400	$\mu\text{s}$
<b>PROTECTION CIRCUITS</b>						
Overcurrent Threshold	$I_{OCP}$		3.0	-	-	A
Overcurrent Blank Time	$t_{OCBLK}$		2.9	3.4	3.9	$\mu\text{s}$
Overcurrent Off-Time	$t_{OCP}$		1.0	1.2	1.4	ms
UVLO Enable Threshold	$V_{BBUVLO}$	$V_{BB}$ rising	5.1	-	5.4	V
UVLO Hysteresis	$V_{BBUVLO}$		250	300	350	mV
VCP Undervoltage	$V_{CPUVLO}$	$V_{CP}$ falling	4.0	4.5	5.0	V
Thermal Warning Temperature	$T_{JW}$	Temperature increasing	-	160	-	$^\circ\text{C}$
Thermal Warning Hysteresis	$\Delta T_{JWHYS}$	Recovery = $T_{JW} - \Delta T_J$	-	20	-	$^\circ\text{C}$
Thermal Shutdown Temperature	$T_{JSD}$	Temperature increasing	155	175	-	$^\circ\text{C}$
Thermal Shutdown Hysteresis	$\Delta T_{JSDHYS}$	Recovery = $T_{JSD} - \Delta T_J$	-	20	-	$^\circ\text{C}$

[1] For input and output current specifications, negative current is defined as coming out of (sourcing) the specified device pin.

[2] For Range G devices, specified limits are tested at a single temperature and assured over operating temperature range by design and characterization.

## FUNCTIONAL DESCRIPTION

### Device Operation

The A5950 is designed to operate DC motors. The output drivers are capable of 40 V and 3 A peak operating currents. Actual 100% steady-state DC current capability depends on thermal capability of the package and PCB, and ambient temperature. N-channel DMOS drivers feature internal synchronous rectification to reduce power dissipation. Peak current can be regulated by fixed off-time pulse-width-modulated (PWM) control circuitry.

Protection circuitry includes thermal shutdown, protection against shorted loads, or protection against output shorts to ground or supply. Undervoltage lockout prevents damage by keeping the outputs off until the driver has enough power supply voltage to operate normally.

### Internal PWM Current Control

When the OCLSEL input is left open or tied high, peak output current is set by sensing the current through an external sense resistor.

$$I_{PEAK} = V_{REF} / (10 \times R_{SENSE})$$

When the peak current is exceeded, the driver will operate in mixed decay mode for fixed time  $t_{OFF}$  before re-enabling the next drive cycle.

To disable the current control feature, leave OCLSEL open or tie OCLSEL high, and connect LSS to GND.

### Blank Function

The internal current sense circuit is ignored for some time after PWM transitions so as not to falsely sense overcurrent events due to motor capacitance and switching transients. This blank time, typically 3  $\mu$ s, results in a minimum on-time of the PWM.

### Standby Mode

Low-power standby mode is activated when RESETn is low. Low-power standby mode disables most of the internal circuitry, including the charge pump and the regulator. When the A5950 is coming out of standby mode, the charge pump should be allowed to reach its regulated voltage (a maximum delay of 400  $\mu$ s) before any PWM commands are issued to the device.

### Overcurrent Protection

A current monitor will protect the IC from damage due to output shorts. If a short is detected, the IC will disable the outputs. The fault latch is cleared after a timer of duration  $t_{OCP}$  expires, and the outputs are re-enabled. During OCP events, the absolute maximum ratings may be exceeded for a short time before the device latches off.

### Thermal Monitoring

If the die temperature increases to approximately  $T_{JSD}$ , the full bridge outputs will be disabled until the internal temperature falls below a hysteresis level of  $T_{JSDHYS}$ . Thermal warning occurs approximately 20 degrees less than  $T_{JSD}$ . Thermal warning triggers a fault but does not disable the drivers.

### OCL Option

If the OCLSEL input is left open or tied high, inrush and stall current can be controlled by selection of VREF and the sense resistor value. If the OCLSEL input is connected to GND, the VREF pin is ignored, and the bridge outputs are latched off when the voltage on SENSE exceeds 500 mV typically. While the outputs are latched off in this condition, the FAULTn output will be asserted and pulled low. As with OCP events, the device will then be re-enabled after a timer of duration  $t_{OCP}$  expires.

### FAULTn Output

FAULTn is an open-drain output and is driven low to indicate any of the following conditions:

1. OCP fault event – Short to VBB, GND, shorted load
2. OCL event (if OCLSEL = low)
3. Thermal warning
4. Undervoltage (VBB or VCP)

### AIOUT

An analog output can be used to monitor the load current flowing through the external sense resistor (if a sense resistor is installed). Positive voltage on the sense resistor is gained by 5 and output on the AIOUT terminal. Negative voltage on the sense resistor is gained by  $-5$  and output on the AIOUT terminal. As the load current does not flow through the sense resistor during a slow-decay (brake) condition, the AIOUT output is approximately 0 V when in slow-decay.

Table 1: Control Logic

RESETn	PHASE	ENABLE	MODE	$I > I_{CL}$	OUT1	OUT2	Function
1	1	1	X	false	H	L	Forward
1	0	1	X	false	L	H	Reverse
1	X	0	1	false	H	H	Brake (slow decay)
1	1	0	0	false	L	H	Fast Decay SR <sup>[1]</sup>
1	0	0	0	false	H	L	Fast Decay SR <sup>[1]</sup>
1	1	1	X	true	L/H	H	Chop (mixed decay) <sup>[1]</sup>
1	0	1	X	true	H	L/H	Chop (mixed decay) <sup>[1]</sup>
0	X	X	X	X	Z	Z	Standby Mode

<sup>[1]</sup> Outputs change to Hi-Z state when in fast decay and load current approaches zero.

PIN STRUCTURES

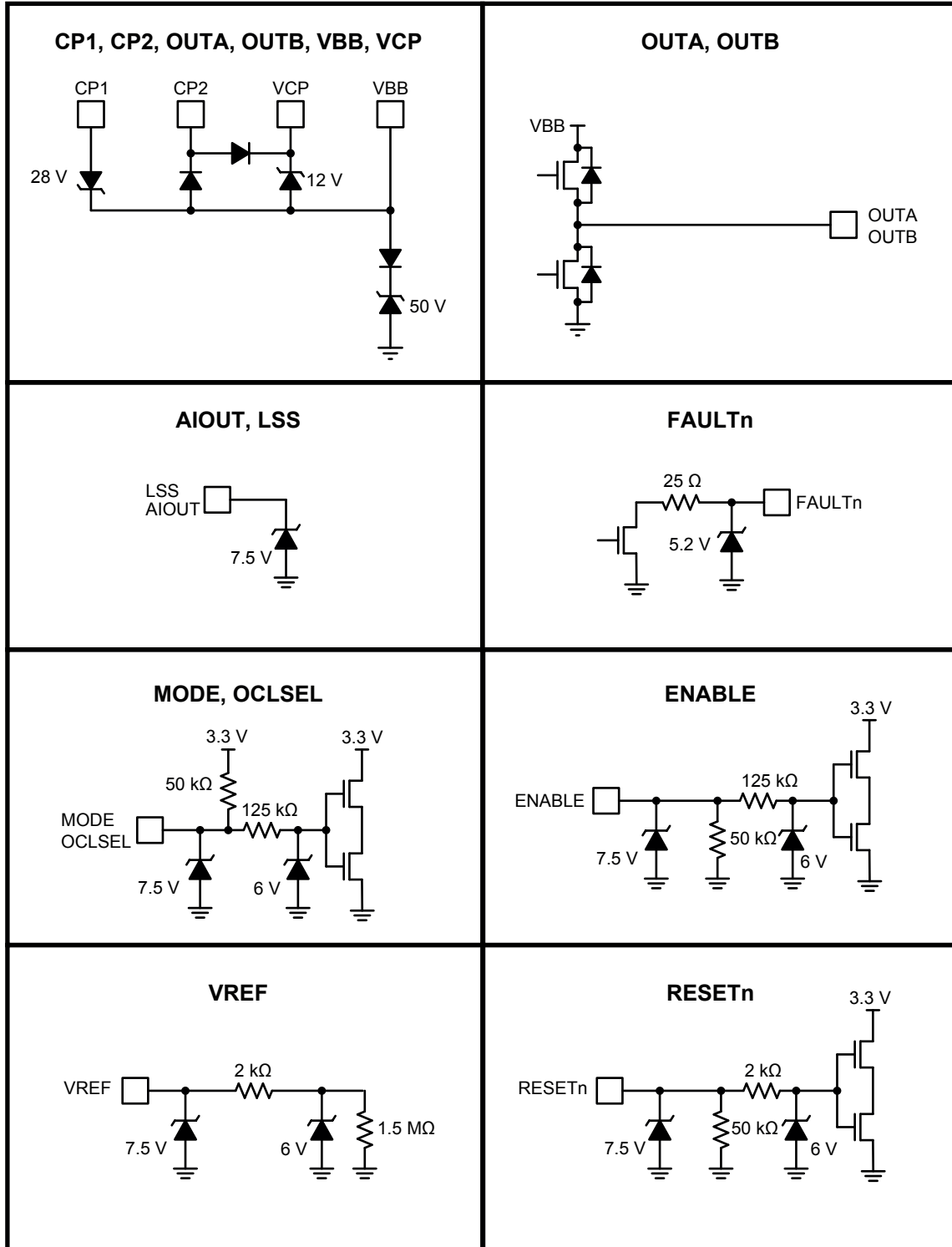

PACKAGE OUTLINE DRAWINGS

For Reference Only – Not for Tooling Use

(Reference Allegro DWG-0000222 Rev. 4 or JEDEC MO-220WGGC.)

Dimensions in millimeters – NOT TO SCALE.

Exact case and lead configuration at supplier discretion within limits shown.

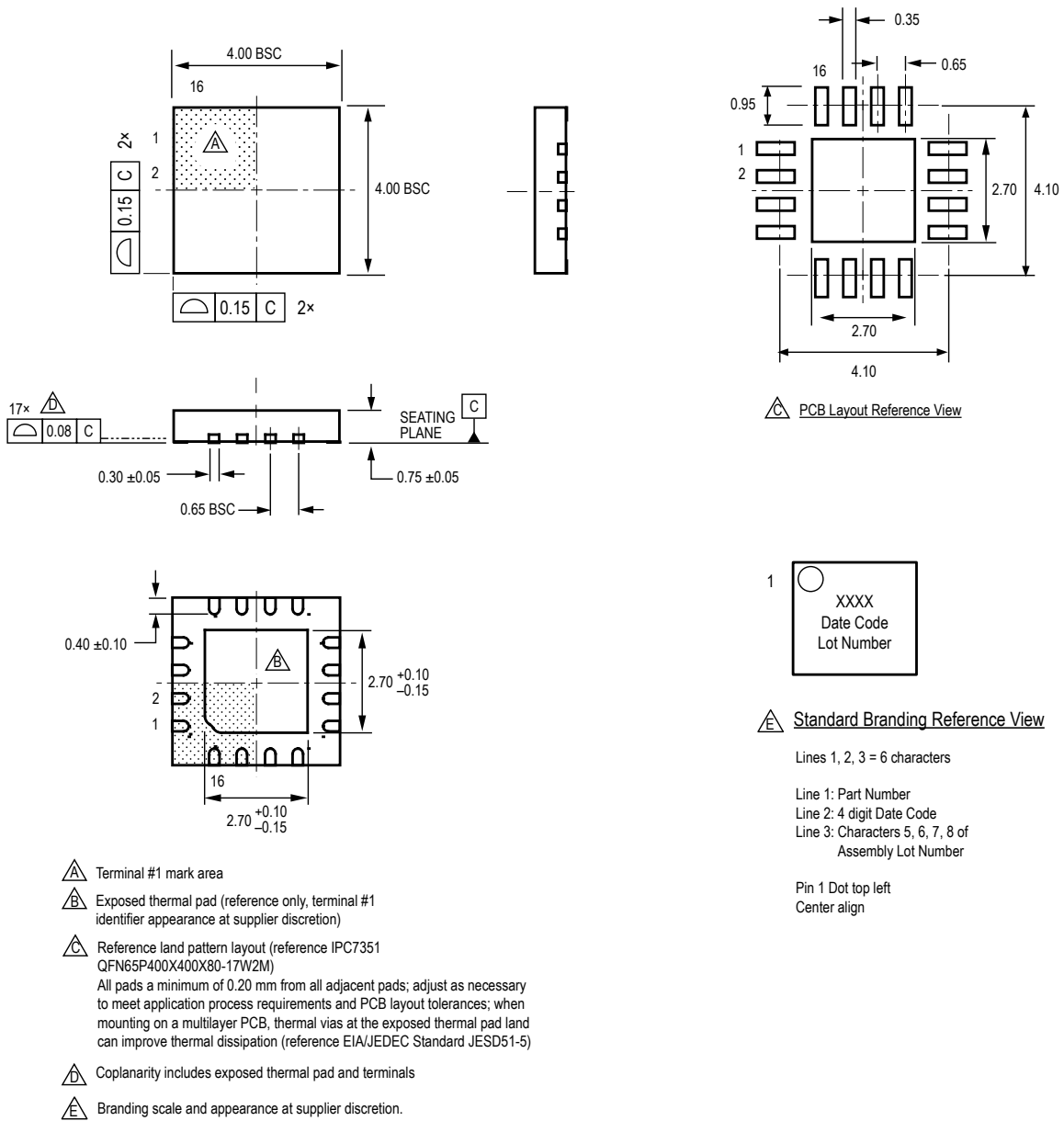

Figure 2: EU Package, 16-Lead QFN with Exposed Thermal Pad

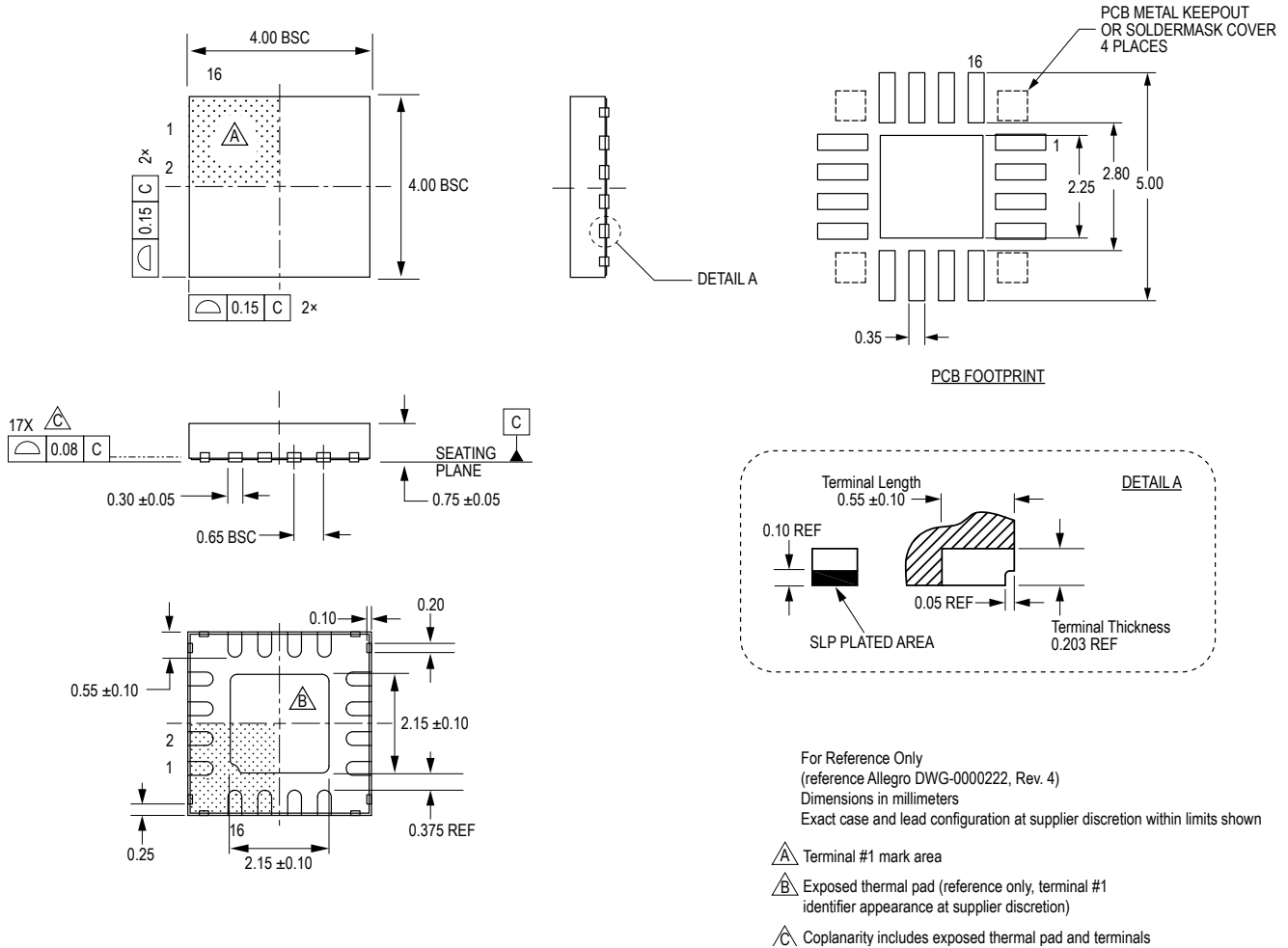

Figure 3: EU Package, 16-Lead QFN with Exposed Thermal Pad and Wettable Flank

**For Reference Only – Not for Tooling Use**

(Reference JEDEC MO-153 ABT; Allegro DWG-0000379, Rev. 3)

Dimensions in millimeters – NOT TO SCALE

Dimensions exclusive of mold flash, gate burrs, and dambar protrusions

Exact case and lead configuration at supplier discretion within limits shown

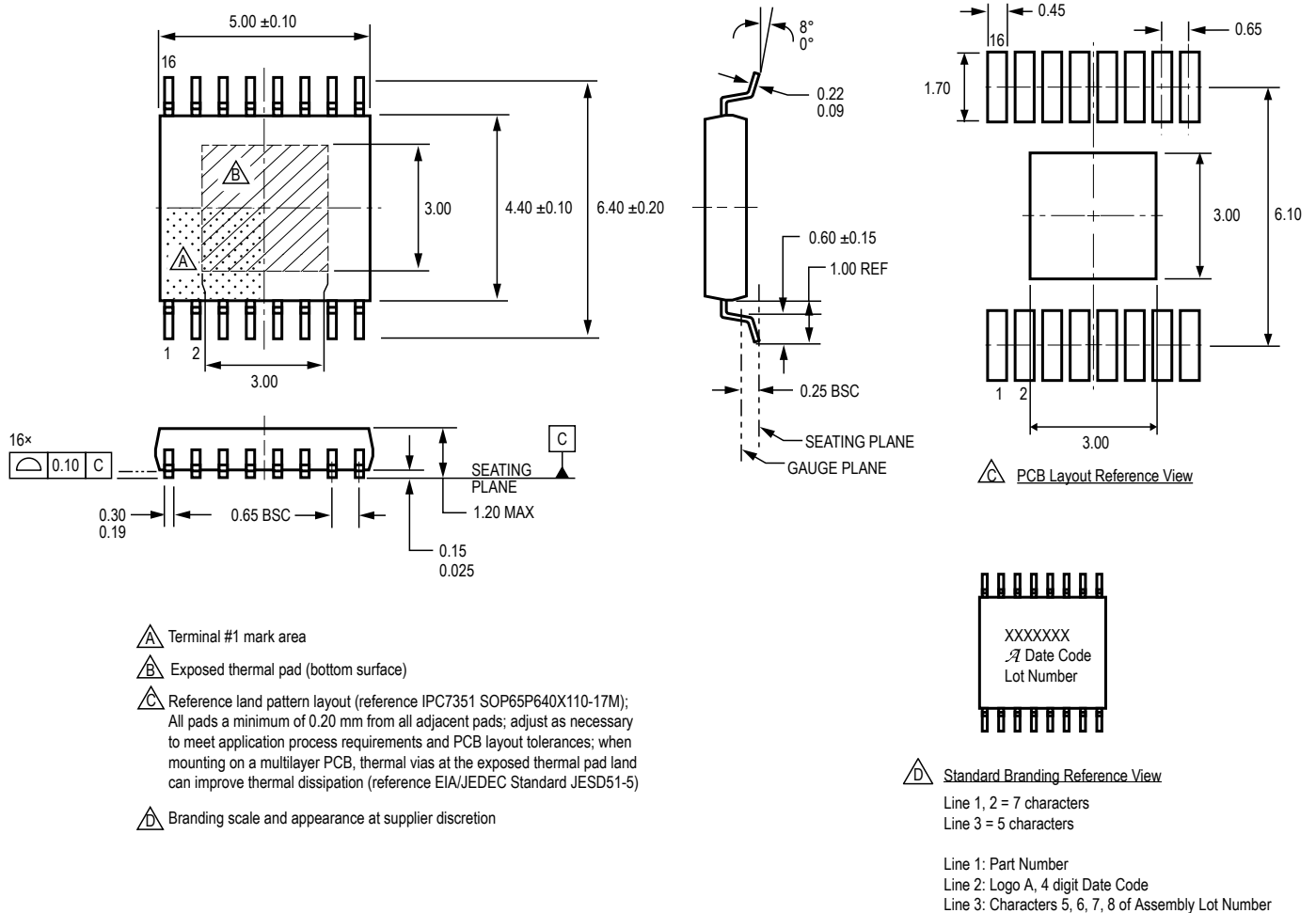

**Figure 4: LP Package, 16-Lead TSSOP with Exposed Thermal Pad**

## Revision History

Number	Date	Description
–	November 14, 2016	Initial release
1	April 24, 2017	Updated Selection Guide
2	May 11, 2017	Corrected packing options in Selection Guide
3	June 22, 2017	Added Pin Structures
4	September 8, 2017	Update automotive qualification to grade 0 (p. 1); updated test conditions Junction Temperature maximum, Standby Bias Current, and $R_{DSON}$ values (p. 4-5)
5	September 12, 2018	Minor editorial updates
6	September 16, 2019	Minor editorial updates
7	January 6, 2021	Added PCB Layout to EU-16 wettable flank package drawing (p. 10)
8	February 9, 2022	Updated package drawings (pages 9-11)

Copyright 2022, Allegro MicroSystems.

Allegro MicroSystems reserves the right to make, from time to time, such departures from the detail specifications as may be required to permit improvements in the performance, reliability, or manufacturability of its products. Before placing an order, the user is cautioned to verify that the information being relied upon is current.

Allegro's products are not to be used in any devices or systems, including but not limited to life support devices or systems, in which a failure of Allegro's product can reasonably be expected to cause bodily harm.

The information included herein is believed to be accurate and reliable. However, Allegro MicroSystems assumes no responsibility for its use; nor for any infringement of patents or other rights of third parties which may result from its use.

Copies of this document are considered uncontrolled documents.

For the latest version of this document, visit our website:

[www.allegromicro.com](http://www.allegromicro.com)

## Looking for pricing, stock, or lifecycle information?

Click below to explore more details on WIN SOURCE:

- ⊖ [View A5950KEUSR-J on WIN SOURCE](#)
- ⊖ [Allegro MicroSystems, LLC Information](#)

## Optimize Your Supply Chain with WIN SOURCE Solutions

- ✓ Global Sourcing Solution
- ✓ Obsolete Management
- ✓ Cost Control Management
- ✓ Shortage Management
- ✓ Alternative Solution
- ✓ Excess Inventory Management