



**THE DATASHEET OF  
ALS31000LLHALX**



## Unidirectional Linear Hall-Effect Sensor IC with Analog Output in Miniature Low-Profile Surface-Mount Package

### FEATURES AND BENEFITS

- 5 V supply operation
- QVO temperature coefficient programmed at Allegro™ for improved accuracy
- Miniature package options
- High-bandwidth, low-noise analog output
- High-speed chopping scheme minimizes QVO drift across operating temperature range
- Temperature-stable quiescent voltage output and sensitivity
- Precise recoverability after temperature cycling
- Output voltage clamps provide short-circuit diagnostic capabilities
- Undervoltage lockout (UVLO)
- Wide ambient temperature range:  $-40^{\circ}\text{C}$  to  $150^{\circ}\text{C}$
- Immune to mechanical stress
- Enhanced EMC performance for stringent automotive applications

### Package:

3-pin SOT23-W  
 $2\text{ mm} \times 3\text{ mm} \times 1\text{ mm}$   
 (suffix LH)

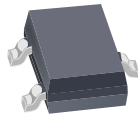

Not to scale

### DESCRIPTION

New applications for linear output Hall-effect sensors, such as displacement and angular position, require higher accuracy and smaller package sizes. The Allegro ALS31000 linear Hall-effect sensor IC has been designed specifically to meet both requirements.

The accuracy of this device is enhanced via end-of-line optimization. The ALS31000 features non-volatile memory to optimize device sensitivity and the quiescent voltage output (QVO: output in the absence of a magnetic field) for a given application or circuit. Optimized performance is sustained across the full operating temperature range by programming the temperature coefficient for both sensitivity and QVO at Allegro end-of-line test.

This ratiometric Hall-effect sensor IC provides a voltage output proportional to the applied magnetic field. The quiescent voltage output is adjusted to around 0.7 V and the output sensitivity is set to 2.4 mV/G.

The features of this linear device make it ideal for use in automotive and industrial applications requiring high accuracy and operation across an extended temperature range,  $-40^{\circ}\text{C}$  to  $150^{\circ}\text{C}$ .

Each BiCMOS monolithic circuit integrates: a Hall element, temperature-compensating circuitry to reduce the intrinsic sensitivity drift of the Hall element, a small-signal high-gain amplifier, a clamped low-impedance output stage, and a proprietary dynamic offset cancellation technique.

*Continued on the next page...*

### Functional Block Diagram

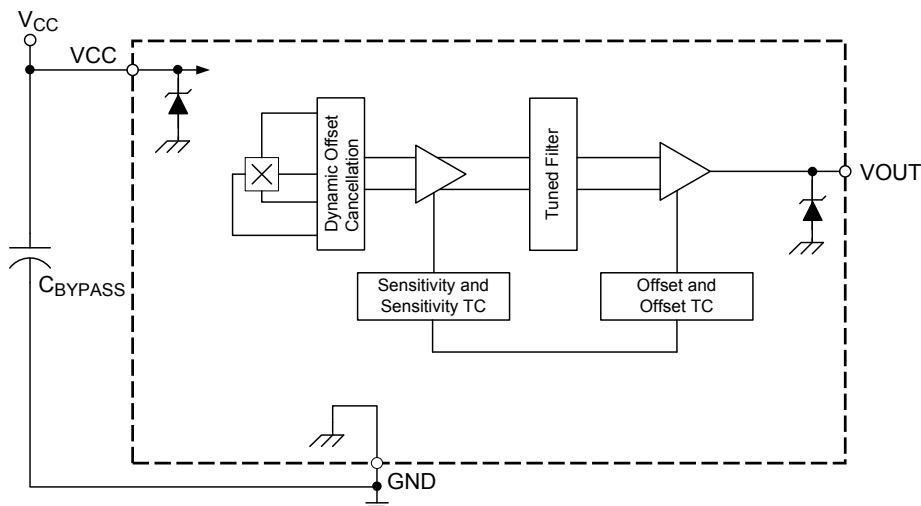

# ALS31000

## Unidirectional Linear Hall-Effect Sensor IC with Analog Output in Miniature Low-Profile Surface-Mount Package

### DESCRIPTION (CONTINUED)

The ALS31000 sensor IC is offered in the LH package style: a SOT-23W style, miniature, low-profile package for surface-mount applications. The package is lead (Pb) free, with 100% matte-tin leadframe plating.

### SELECTION GUIDE

Part Number	Packing*	Package
ALS31000LLHALX	10,000 pieces per reel	3-pin SOT-23W surface-mount

\*Contact Allegro™ for additional packing options



### ABSOLUTE MAXIMUM RATINGS

Characteristic	Symbol	Notes	Rating	Unit
Forward Supply Voltage	$V_{CC}$		8	V
Reverse Supply Voltage	$V_{RCC}$		-0.1	V
Forward Output Voltage	$V_{OUT}$		7	V
Reverse Output Voltage	$V_{ROUT}$		-0.1	V
Output Source Current	$I_{OUT(SOURCE)}$	VOUT to GND	2	mA
Output Sink Current	$I_{OUT(SINK)}$	VCC to VOUT	10	mA
Operating Ambient Temperature	$T_A$	Range L	-40 to 150	°C
Maximum Junction Temperature	$T_J(max)$		165	°C
Storage Temperature	$T_{stg}$		-65 to 170	°C

### THERMAL CHARACTERISTICS: May require derating at maximum conditions; see application information

Characteristic	Symbol	Test Conditions <sup>[1]</sup>	Value	Units
Package Thermal Resistance	$R_{\theta JA}$	Package LH, 1-layer PCB with copper limited to solder pads	228	°C/W
		Package LH, 2-layer PCB with 0.463 in <sup>2</sup> of copper area each side connected by thermal vias	110	°C/W

<sup>[1]</sup> Additional thermal information available on Allegro website

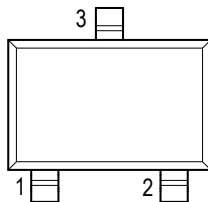

LH Package Pinout Diagram

### Terminal List Table

Name	Number	Description
VCC	1	Input power supply; tie to GND with bypass capacitor
VOUT	2	Output signal
GND	3	Ground

**OPERATING CHARACTERISTICS:** Valid over  $T_A$ ,  $C_{BYPASS} = 0.1 \mu\text{F}$ ,  $V_{CC} = 5 \text{ V}$ , unless otherwise noted

Characteristic	Symbol	Test Conditions	Min.	Typ.	Max.	Unit <sup>[2]</sup>
<b>ELECTRICAL CHARACTERISTICS</b>						
Supply Voltage	$V_{CC}$		4.5	5.0	5.5	V
Undervoltage Threshold <sup>[3]</sup>	$V_{UVLOHI}$	Tested at $T_A = 25^\circ\text{C}$ and $T_A = 150^\circ\text{C}$ (device powers-on)	–	–	3	V
	$V_{UVLOLO}$	Tested at $T_A = 25^\circ\text{C}$ and $T_A = 150^\circ\text{C}$ (device powers-off)	2.5	–	–	V
Supply Current	$I_{CC}$	No load on VOUT	–	9	11.5	mA
Power-On Time <sup>[4][5]</sup>	$t_{PO}$	$T_A = 25^\circ\text{C}$ , $C_L(\text{PROBE}) = 10 \text{ pF}$	–	50	–	$\mu\text{s}$
$V_{CC}$ Ramp Time <sup>[4][5]</sup>	$t_{VCC}$	$T_A = 25^\circ\text{C}$	0.005	–	100	ms
$V_{CC}$ Off Level <sup>[4][5]</sup>	$V_{CCOFF}$	$T_A = 25^\circ\text{C}$	0	–	0.55	V
Delay to Clamp <sup>[4][5]</sup>	$t_{CLP}$	$T_A = 25^\circ\text{C}$ , $C_L = 10 \text{ nF}$	–	30	–	$\mu\text{s}$
Supply Zener Clamp Voltage	$V_Z$	$T_A = 25^\circ\text{C}$ , $I_{CC} = 14.5 \text{ mA}$	6	7.3	–	V
Internal Bandwidth <sup>[5]</sup>	$BW_i$	Small signal –3 dB	–	20	–	kHz
Chopping Frequency <sup>[5][6]</sup>	$f_C$	$T_A = 25^\circ\text{C}$	–	400	–	kHz
<b>OUTPUT CHARACTERISTICS</b>						
Output Referred Noise <sup>[5]</sup>	$V_N$	$V_{CC} = 5 \text{ V}$ , $T_A = 25^\circ\text{C}$ , $C_{BYPASS} = \text{open}$ , no load on VOUT	–	4	–	$\text{mV}_{(p-p)}$
Input Referred RMS Noise Density <sup>[5]</sup>	$V_{NRMS}$	$V_{CC} = 5 \text{ V}$ , $T_A = 25^\circ\text{C}$ , $C_{BYPASS} = \text{open}$ , no load on VOUT, $f_{\text{measured}} \ll BW_i$	–	1.5	–	$\text{mG}/\sqrt{\text{Hz}}$
DC Output Resistance <sup>[5]</sup>	$R_{OUT}$		–	<1	–	$\Omega$
Output Load Resistance <sup>[5]</sup>	$R_L$	VOUT to GND	4.7	–	–	k $\Omega$
Output Load Capacitance <sup>[5]</sup>	$C_L$	VOUT to GND	–	–	10	nF
Output Voltage Clamp <sup>[7][8]</sup>	$V_{CLPHIGH}$	$T_A = 25^\circ\text{C}$ , $R_L = 10 \text{ k}\Omega$ (VOUT to GND)	4.35	4.5	4.65	V
	$V_{CLFLOW}$	$T_A = 25^\circ\text{C}$ , $R_L = 10 \text{ k}\Omega$ (VOUT to VCC)	0.37	0.51	0.65	V
Sensitivity	Sens	$T_A = 25^\circ\text{C}$	2.304	2.4	2.496	$\text{mV}/\text{G}$
Quiescent Voltage Output (QVO)	$V_{OUT(Q)}$	$T_A = 25^\circ\text{C}$	0.68	0.7	0.72	V
Sensitivity Temperature Coefficient	$TC_{\text{Sens}}$	Programmed at $T_A = 150^\circ\text{C}$ , calculated relative to Sens at $25^\circ\text{C}$	0.08	0.12	0.16	$\%/^\circ\text{C}$

Continued on the next page...

**OPERATING CHARACTERISTICS (continued):** Valid over  $T_A$ ,  $C_{BYPASS} = 0.1 \mu\text{F}$ ,  $V_{CC} = 5 \text{ V}$ , unless otherwise noted

Characteristic	Symbol	Test Conditions	Min.	Typ.	Max.	Unit <sup>[2]</sup>
<b>ERROR COMPONENTS</b>						
Linearity Sensitivity Error	$\text{Lin}_{\text{ERR}}$		–	$\pm 1.5$	–	%
Ratiometry Quiescent Voltage Output Error <sup>[9]</sup>	$\text{Rat}_{\text{VOUT(Q)}}$	Across supply voltage range (relative to $V_{CC} = 5 \text{ V}$ )	–	$\pm 1.5$	–	%
Ratiometry Sensitivity Error <sup>[9]</sup>	$\text{Rat}_{\text{Sens}}$	Across supply voltage range (relative to $V_{CC} = 5 \text{ V}$ )	–	$\pm 1.5$	–	%
Ratiometry Clamp Error <sup>[10]</sup>	$\text{Rat}_{\text{VOUTCLP}}$	$T_A = 25^\circ\text{C}$ , across supply voltage range (relative to $V_{CC} = 5 \text{ V}$ )	–	$\pm 1.5$	–	%
<b>DRIFT CHARACTERISTICS</b>						
Typical Quiescent Voltage Output Drift Across Temperature Range	$\Delta V_{\text{OUT(Q)}}$	$T_A = 150^\circ\text{C}$	–10	–	20	mV
Sensitivity Drift Due to Package Hysteresis <sup>[11]</sup>	$\Delta \text{Sens}_{\text{PKG}}$	$T_A = 25^\circ\text{C}$ , after temperature cycling	–	$\pm 2$	–	%

<sup>[2]</sup> 1 G (gauss) = 0.1 mT (millitesla),

<sup>[3]</sup> On power-up, the output of the device is held low until  $V_{CC}$  exceeds  $V_{\text{UVLOHI}}$ . After the device is powered, the output remains valid until  $V_{CC}$  drops below  $V_{\text{UVLOLO}}$ , when the output is pulled low.

<sup>[4]</sup> See the Characteristic Definitions section.

<sup>[5]</sup> Determined by design and characterization; not evaluated at final test.

<sup>[6]</sup>  $f_C$  varies as much as approximately  $\pm 20\%$  across the full operating ambient temperature range and process.

<sup>[7]</sup> Parameter is tested at wafer probe only.

<sup>[8]</sup>  $V_{\text{CLPLOW}}$  and  $V_{\text{CLPHIGH}}$  scale with  $V_{CC}$  due to ratiometry.

<sup>[9]</sup> Percent change from actual value at  $V_{CC} = 5 \text{ V}$ , for a given temperature.

<sup>[10]</sup> Percent change from actual value at  $V_{CC} = 5 \text{ V}$ ,  $T_A = 25^\circ\text{C}$ .

<sup>[11]</sup> Sensitivity drift through the life of the part,  $\Delta \text{Sens}_{\text{LIFE}}$ , can have a typical error value  $\pm 3\%$  in addition to package hysteresis effects.

### Characteristic Definitions

**Power-On Time.** When the supply is ramped to its operating voltage, the device output requires a finite time to react to an input magnetic field. Power-On Time,  $t_{PO}$ , is defined as the time it takes for the output voltage to begin responding to an applied magnetic field after the power supply has reached its minimum specified operating voltage,  $V_{CC}(\text{min})$ , as shown in figure 1.

**Delay to Clamp.** A large magnetic input step may cause the clamp to overshoot its steady-state value. The Delay to Clamp,  $t_{CLP}$ , is defined as the time it takes for the output voltage to settle within 1% of its steady-state value, after initially passing through its steady-state voltage, as shown in figure 2.

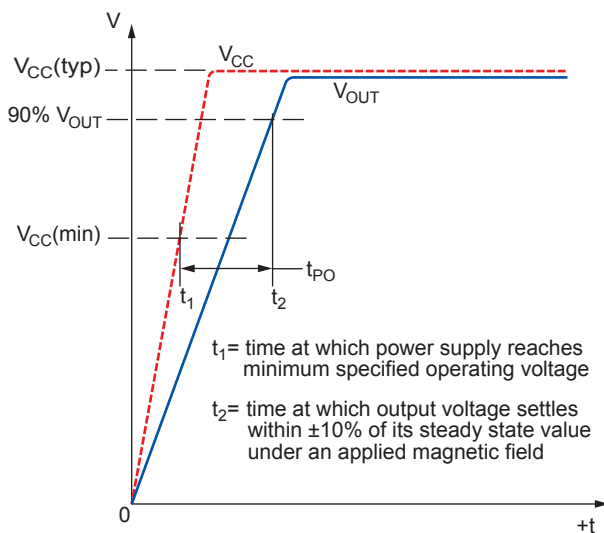

Figure 1. Definition of Power On Time,  $t_{PO}$

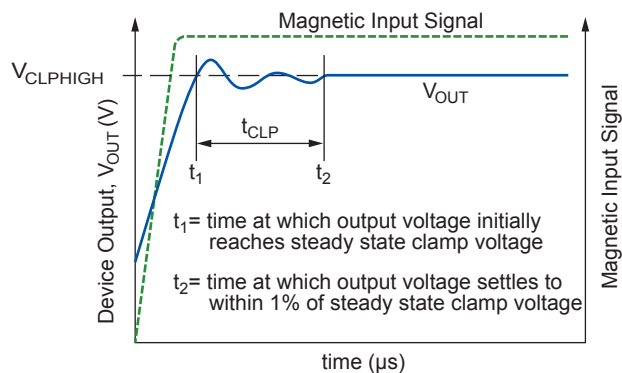

Figure 2. Definition of Delay to Clamp,  $t_{CLP}$

**Quiescent Voltage Output.** In the quiescent state (i.e. no significant magnetic field:  $B = 0$  G), the output,  $V_{OUT(Q)}$ , is at a constant ratio to the supply voltage,  $V_{CC}$ , across the entire operating ranges of  $V_{CC}$  and Operating Ambient Temperature,  $T_A$ .

**Quiescent Voltage Output Drift Across Temperature Range.** Due to internal component tolerances and thermal considerations, the Quiescent Voltage Output,  $V_{OUT(Q)}$ , may drift due to temperature changes within the Operating Ambient Temperature,  $T_A$ . For purposes of specification, the Quiescent Voltage Output Drift Across Temperature Range,  $\Delta V_{OUT(Q)}$  (mV), is defined as:

$$\Delta V_{OUT(Q)} = V_{OUT(Q)(T_A)} - V_{OUT(Q)(25^\circ\text{C})} \quad (1)$$

**Sensitivity.** The presence of a south-pole magnetic field perpendicular to the branded surface of the package face increases the output voltage from its quiescent value toward the supply voltage rail. The amount of the output voltage increase is proportional to the magnitude of the magnetic field applied. This proportionality is specified as the magnetic sensitivity, Sens (mV/G), of the device and is defined as:

$$\text{Sens} = \frac{V_{OUT(B2)} - V_{OUT(B1)}}{B2 - B1} \quad (2)$$

where  $B1$  and  $B2$  are two magnetic fields of different magnitude.

**Sensitivity Temperature Coefficient.** The device sensitivity changes as temperature changes, with respect to its Sensitivity Temperature Coefficient,  $TC_{\text{SENS}}$ .  $TC_{\text{SENS}}$  is programmed at  $150^\circ\text{C}$ , and calculated relative to the baseline sensitivity programming temperature of  $25^\circ\text{C}$ .  $TC_{\text{SENS}}$  is defined as:

$$TC_{\text{SENS}} = \left( \frac{\text{Sens}_{T2} - \text{Sens}_{T1}}{\text{Sens}_{T1}} \times 100 \right) \left( \frac{1}{T2 - T1} \right) \quad (\%/^\circ\text{C}) \quad (3)$$

where  $T1$  is the baseline Sens programming temperature of  $25^\circ\text{C}$ , and  $T2$  is the  $TC_{\text{SENS}}$  programming temperature of  $150^\circ\text{C}$ .

The ideal value of Sens across the full ambient temperature range,  $\text{Sens}_{\text{IDEAL}(T_A)}$ , is defined as:

$$\text{Sens}_{\text{IDEAL}(T_A)} = \text{Sens}_{T1} \times [100 (\%) + TC_{\text{SENS}} (T_A - T1)] \quad (4)$$

**Sensitivity Drift Across Temperature Range.** Second-order sensitivity temperature coefficient effects cause the magnetic sensitivity, Sens, to drift from its ideal value across the

operating ambient temperature range,  $T_A$ . For purposes of specification, the Sensitivity Drift Across Temperature Range,  $\Delta\text{Sens}_{TC}$ , is defined as:

$$\Delta\text{Sens}_{TC} = \frac{\text{Sens}_{T_A} - \text{Sens}_{\text{IDEAL}(T_A)}}{\text{Sens}_{\text{IDEAL}(T_A)}} \times 100 \quad (\%) \quad (5)$$

**Sensitivity Drift Due to Package Hysteresis.** Package stress and relaxation can cause the device sensitivity at  $T_A = 25^\circ\text{C}$  to change during and after temperature cycling. This change in sensitivity follows a hysteresis curve. For purposes of specification, the Sensitivity Drift Due to Package Hysteresis,  $\Delta\text{Sens}_{PKG}$ , is defined as:

$$\Delta\text{Sens}_{PKG} = \frac{\text{Sens}_{(25^\circ\text{C})(2)} - \text{Sens}_{(25^\circ\text{C})(1)}}{\text{Sens}_{(25^\circ\text{C})(1)}} \times 100 \quad (\%) \quad (6)$$

where  $\text{Sens}_{(25^\circ\text{C})(1)}$  is the programmed value of sensitivity at  $T_A = 25^\circ\text{C}$ , and  $\text{Sens}_{(25^\circ\text{C})(2)}$  is the value of sensitivity at  $T_A = 25^\circ\text{C}$  after temperature cycling  $T_A$  up to  $150^\circ\text{C}$ , down to  $-40^\circ\text{C}$ , and back to up  $25^\circ\text{C}$ .

**Linearity Sensitivity Error.** The ALS31000 is designed to provide linear output in response to a ramping applied magnetic field. Consider two magnetic fields, B1 and B2. Ideally, the sensitivity of a device is the same for both fields, for a given supply voltage and temperature. Linearity error is present when there is a difference between the sensitivities measured at B1 and B2.

Linearity error (%) is measured and defined as:

$$\text{Lin}_{ERR} = \left(1 - \frac{\text{Sens}_{(B2)}}{\text{Sens}_{(B1)}}\right) \times 100 \quad (\%) \quad (7)$$

where:

$$\text{Sens}_{B_x} = \frac{|V_{OUT(B_x)} - V_{OUT(Q)}|}{B_x} \quad (8)$$

and B1 and B2 are positive magnetic fields, with respect to the quiescent voltage output, such that  $|B2| > |B1|$ .

The output voltage clamps,  $V_{CLPHIGH}$  and  $V_{CLPLOW}$ , limit the operating magnetic range of the applied field in which the device provides a linear output. The maximum positive and negative applied magnetic fields in the operating range can be calculated:

$$|B_{MAX(+)}| = \frac{V_{CLPHIGH} - V_{OUT(Q)}}{\text{Sens}} \quad (9)$$

$$|B_{MAX(-)}| = \frac{V_{OUT(Q)} - V_{CLPLOW}}{\text{Sens}} \quad (10)$$

**Ratiometry Error.** The ALS31000 provides ratiometric output. This means that the Quiescent Voltage Output,  $V_{OUT(Q)}$ , magnetic sensitivity, Sens, and clamp voltages,  $V_{CLPHIGH}$  and  $V_{CLPLOW}$ , are proportional to the supply voltage,  $V_{CC}$ . When the supply voltage increases or decreases by a certain percentage, each characteristic also increases or decreases by the same percentage. Error is the difference between the measured change in the supply voltage relative to 5 V, and the measured change in each characteristic.

The ratiometric error in quiescent voltage output,  $\text{Rat}_{V_{OUT(Q)}} (\%)$ , for a given supply voltage,  $V_{CC}$ , is defined as:

$$\text{Rat}_{V_{OUT(Q)}} = \left(1 - \frac{V_{OUT(Q)(V_{CC})} / V_{OUT(Q)(5V)}}{V_{CC} / 5 (V)}\right) \times 100 \quad (\%) \quad (11)$$

The ratiometric error in magnetic sensitivity,  $\text{Rat}_{\text{Sens}} (\%)$ , for a given supply voltage,  $V_{CC}$ , is defined as:

$$\text{Rat}_{\text{Sens}} = \left(1 - \frac{\text{Sens}_{(V_{CC})} / \text{Sens}_{(5V)}}{V_{CC} / 5 (V)}\right) \times 100 \quad (\%) \quad (12)$$

The ratiometric error in the clamp voltages,  $\text{Rat}_{V_{OUTCLP}} (\%)$ , for a given supply voltage,  $V_{CC}$ , is defined as:

$$\text{Rat}_{V_{OUTCLP}} = \left(1 - \frac{V_{CLP(V_{CC})} / V_{CLP(5V)}}{V_{CC} / 5 (V)}\right) \times 100 \quad (\%) \quad (13)$$

where  $V_{CLP}$  is either  $V_{CLPHIGH}$  or  $V_{CLPLOW}$ .

**Undervoltage Lockout.** The ALS31000 provides an undervoltage lockout feature to ensure the device will output a valid signal when  $V_{CC}$  is above certain threshold  $V_{UVLOHI}$ , and remain valid until  $V_{CC}$  falls below a lower threshold,  $V_{UVLOLO}$ . The undervoltage lockout feature provides a hysteresis of operation to eliminate indeterminate output states.

The output of the ALS31000 is held low (GND) until  $V_{CC}$  exceeds  $V_{UVLOHI}$ . Once  $V_{CC}$  exceeds  $V_{UVLOHI}$ , the device powers up, and the output will provide a ratiometric output voltage proportional to the input magnetic signal and  $V_{CC}$ . If  $V_{CC}$  should drop back down below  $V_{UVLOLO}$ , the output will be pulled low, as shown in Figure 3.

**$V_{CC}$  Ramp Time.** The time taken for  $V_{CC}$  to ramp from 0 V to  $V_{CC}(typ)$ , 5 V (see Figure 4).

**$V_{CC}$  Off Level.** For applications in which the VCC pin of the ALS31000 is being power-cycled (for example using a multiplexer to toggle the part on and off), the specification of  $V_{CC}$  Off Level,  $V_{CCOFF}$ , determines how high a  $V_{CC}$  off voltage can be tolerated while still ensuring proper operation and startup of the device (see Figure 4).

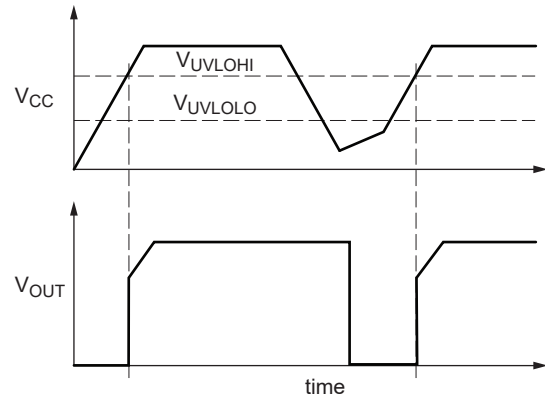

Figure 3. UVLO Operation

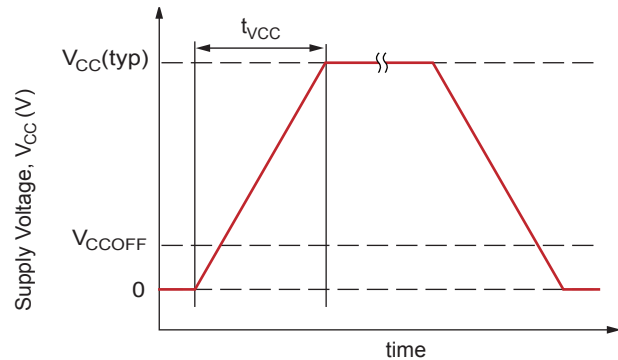

Figure 4. Definition of  $V_{CC}$  Ramp Time,  $t_{VCC}$

### APPLICATION INFORMATION

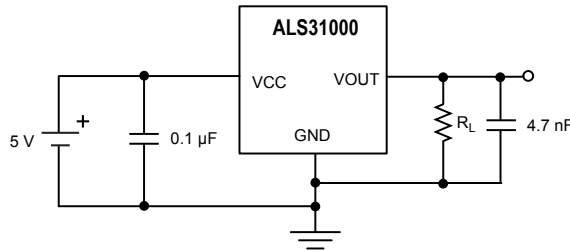

Figure 5. Typical Application Circuit

### CHOPPER STABILIZATION TECHNIQUE

When using Hall-effect technology, a limiting factor for switchpoint accuracy is the small-signal voltage developed across the Hall element. This voltage is disproportionately small relative to the offset that can be produced at the output of the Hall sensor IC. This makes it difficult to process the signal while maintaining an accurate, reliable output over the specified operating temperature and voltage ranges. Chopper stabilization is a unique approach used to minimize Hall offset on the chip. Allegro employs a technique to remove key sources of the output drift induced by thermal and mechanical stresses. This offset reduction technique is based on a signal modulation-demodulation process. The undesired offset signal is separated from the magnetic field-induced signal in the frequency domain, through modulation. The subsequent demodulation acts as a modulation process for the offset, causing the magnetic field-induced signal to recover its original spectrum at base band, while the DC offset becomes a high-frequency signal. The magnetic-sourced signal then can pass

through a low-pass filter, while the modulated DC offset is suppressed. In addition to the removal of the thermal and mechanical stress related offset, this novel technique also reduces the amount of thermal noise in the Hall sensor IC while completely removing the modulated residue resulting from the chopper operation. The chopper stabilization technique uses a high-frequency sampling clock. For demodulation process, a sample-and-hold technique is used. This high-frequency operation allows a greater sampling rate, which results in higher accuracy and faster signal-processing capability. This approach desensitizes the chip to the effects of thermal and mechanical stresses, and produces devices that have extremely stable quiescent Hall output voltages and precise recoverability after temperature cycling. This technique is made possible through the use of a BiCMOS process, which allows the use of low-offset, low-noise amplifiers in combination with high-density logic integration and sample-and-hold circuits.

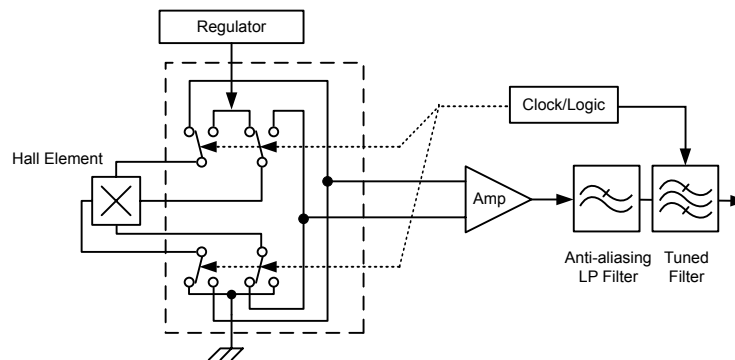

Figure 6. Chopper Stabilization Technique

## Package LH, 3-Pin SOT-23W

### For Reference Only – Not for Tooling Use

(Reference Allegro DWG-0000628, Rev. 1)

NOT TO SCALE

Dimensions in millimeters

Dimensions exclusive of mold flash, gate burrs, and dambar protrusions  
Exact case and lead configuration at supplier discretion within limits shown

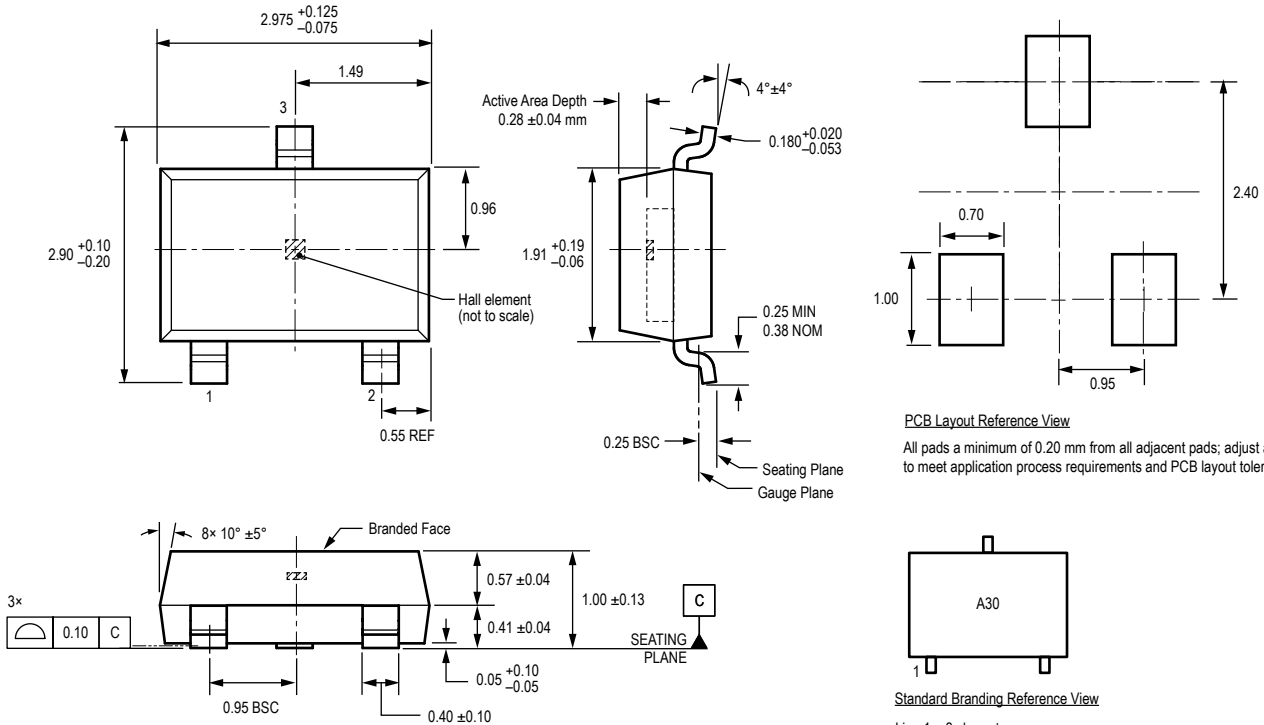

#### PCB Layout Reference View

All pads a minimum of 0.20 mm from all adjacent pads; adjust as necessary to meet application process requirements and PCB layout tolerances

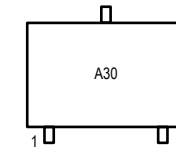

#### Standard Branding Reference View

Line 1 = 3 characters

Branding scale and appearance at supplier discretion

### Revision History

Number	Date	Description
–	September 6, 2016	Initial release
1	September 13, 2016	Updated Chopper Stabilization Technique section
2	February 19, 2019	Updated Undervoltage Lockout section, Figure 3, and minor editorial updates
3	January 20, 2020	Minor editorial updates
4	February 3, 2022	Updated package drawing (page 9)

Copyright 2022, Allegro MicroSystems.

Allegro MicroSystems reserves the right to make, from time to time, such departures from the detail specifications as may be required to permit improvements in the performance, reliability, or manufacturability of its products. Before placing an order, the user is cautioned to verify that the information being relied upon is current.

Allegro's products are not to be used in any devices or systems, including but not limited to life support devices or systems, in which a failure of Allegro's product can reasonably be expected to cause bodily harm.

The information included herein is believed to be accurate and reliable. However, Allegro MicroSystems assumes no responsibility for its use; nor for any infringement of patents or other rights of third parties which may result from its use.

Copies of this document are considered uncontrolled documents.

For the latest version of this document, visit our website:

[www.allegromicro.com](http://www.allegromicro.com)

## Looking for pricing, stock, or lifecycle information?

Click below to explore more details on WIN SOURCE:

- ⊖ [View ALS31000LLHALX on WIN SOURCE](#)
- ⊖ [Allegro MicroSystems, LLC Information](#)

## Optimize Your Supply Chain with WIN SOURCE Solutions

- ✓ Global Sourcing Solution
- ✓ Obsolete Management
- ✓ Cost Control Management
- ✓ Shortage Management
- ✓ Alternative Solution
- ✓ Excess Inventory Management