



**THE DATASHEET OF
ASEK709LLF-35BB-T-DK**



1. RoHS Compliance Required?
YES
All components and assembly practices must be RoHS Compliant.
All assemblies from this TED pack must be RoHS compliant.
Certificates of RoHS compliance must be sent to Allegro for record keeping.
2. Other TED Packs and/or outside Specifications required for build:
No.
3. Are there optional ways to build this TED pack?
Yes.
Please see -OPT Build Options Page.
4. As multiple boards exist under this TED pack number, there is no -000 assembly.
When ordering, the complete 9 digit TED number must be used.
5. Pages with the descriptor "-ASY" are expected to be followed by the assembly person / assembly house. These are the Construction Notes / Assembly Notes pages, and are used to convey building instructions.
6. The notes on the -TST pages are expected to be followed by Allegro; product shall not be sold to customers until the steps on the -TST pages are completed. These are test and verification steps, and are used to test assembly(s) prior to usage and/or selling.
They are not "calibration" procedures as used on production equipment.
7. All photos provided are for reference only; slight variations may result from component second sourcing or later design changes. Photos are intended to convey roughly what completed assembly should look like.
8. All parts ordering shall be done in accordance to specification ENG 07-0002 Revision 4.
Please see 85-04444-001-BOM, see information at bottom.
9. PCB RFQ, PCB Fabrication Drawing, and PCB gerber files are included in the appropriately named zip file (one zip file per board).
10. The -001 PCB does not have to be assembled prior to installation of the Allegro device. All devices may be installed at the same time.
The -001 PCB is documented separately for documentation purposes only.
11. The -001 assembly may be assembled just by itself, and the Allegro device installed at a later date.
12. The -000-ASY Assembly Instructions are to be used for all builds.

Revision OI to Revision A Changes:

1. On Rev OI, the two 3.5mm x 1.63mm slots were not thro-hole plated. This is changed to thro-hole plated.
2. No other changes.

How to convert Rev OI to Rev A:

1. No changes required; Rev OI ok for usage.
It is not possible convert Rev OI to Rev A.

Revision A to Revision B Changes:

1. Labeling changed from "ACS7xx etc" to "ASEK7xx etc".
2. This labeling impacted the ASY, as well as the 10x-BOM's.
3. No functional change.

How to convert Rev A to Rev B:

1. Change labels as indicated in ASY.

Revision B to Revision C Changes:

1. Allegro devices mislabeled: the "B" should be "BB".
2. R13 from 301 to 634 ohm
3. R14 from 523 to 1kohm.
4. R15 from 432 to 825ohm.
5. No functional changes.

How to convert Rev A to Rev B:

1. No changes required.

There are several different assemblies listed under this TED pack.
Build according to Request Number / Option Number / Description / TBD,
as explained below:

#	Request:	Build (1) each of these:	Description:
1	85-0444-001	85-0444-001	Demo board minus part
2	ASEK709LLF-35BB-T	85-0444-100	ASEK709LLF-35BB-T Demo
3	85-0444-100	85-0444-100	ASEK709LLF-35BB-T Demo
4	ASEK709LLF-20BB-T	85-0444-101	ASEK709LLF-20BB-T Demo
5	85-0444-101	85-0444-101	ASEK709LLF-20BB-T Demo

Notes:

1. The -001 PCB does not have to be assembled prior to installation of the Allegro device. All devices may be installed at the same time.
The -001 PCB is documented seperately for documentation purposes only.
2. The -001-ASY Assembly Instructions are to be used for all builds.

ACS709 Demo Board
85-0444-000-TST
Originator: Shawn Upton

Test and Verification
PAGE 1 OF 1

Rev 1
3/20/2009

This page left blank at this time.

Originator: Shawn Upton

1. RoHS Compliance Required?
YES
All components and assembly practices must be RoHS Compliant.
2. Unless otherwise noted below:
 Install surface mount components first.
 Then throughhole parts.
3. The -001 PCB does not have to be assembled prior to installation of the Allegro device. All devices may be installed at the same time.
 The -001 PCB is documented seperately for documentation purposes only.
4. These Assembly Instructions are to be used for all builds.

Labeling:

1. For -001 Assemblies: no labeling is required.
2. For non-001 Assemblies:
 Print a label with the P/N from below, and affix to the top-side silkscreen box.

TED Number:	Label	Description
85-0444-100	ASEK709LLF-35BB-T	ASEK709LLF-35BB-T Demo
85-0444-101	ASEK709LLF-20BB-T	ASEK709LLF-20BB-T Demo

Photo's:

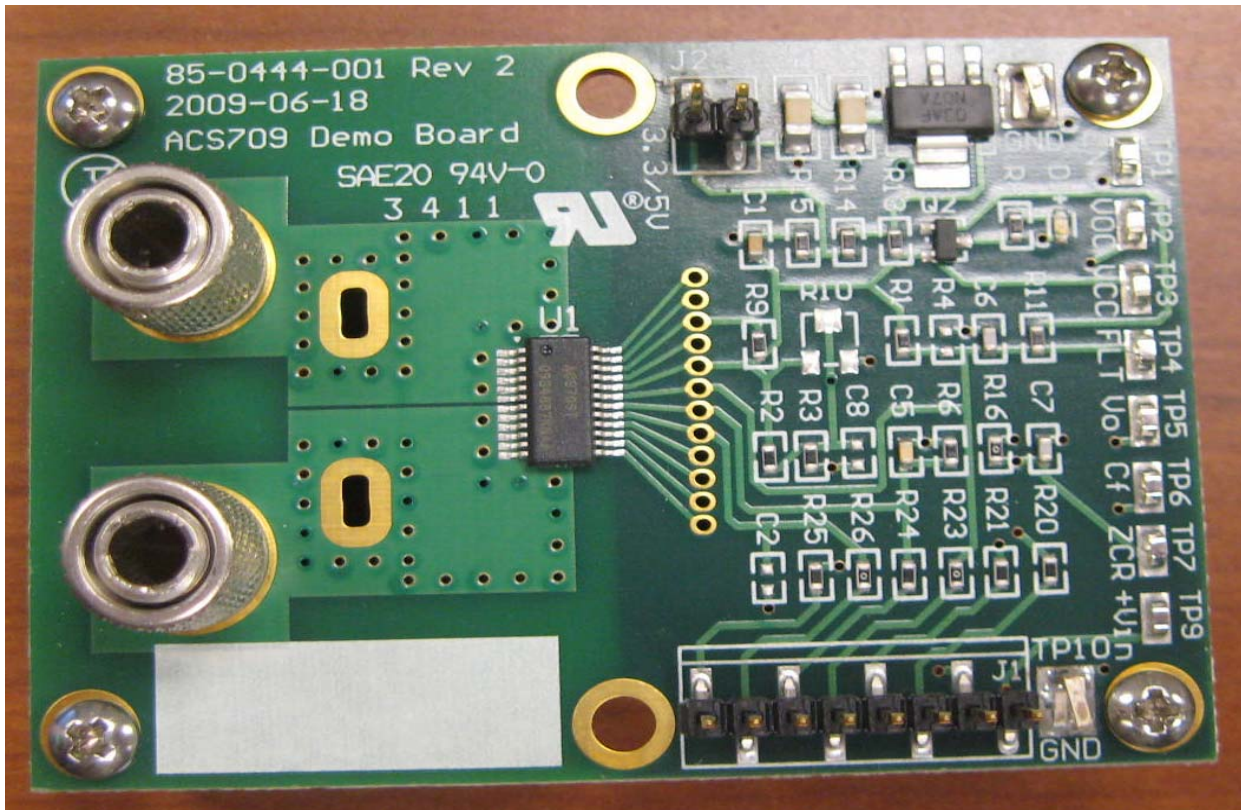

Photo's, continued:

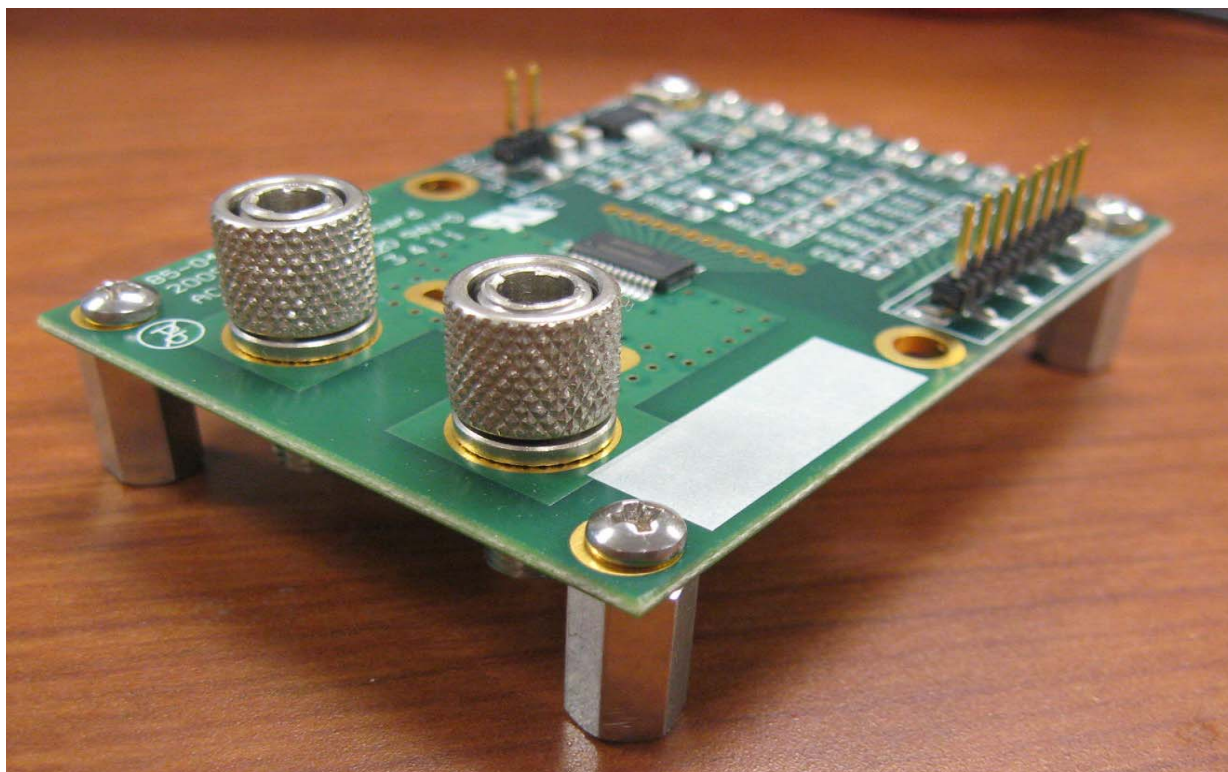
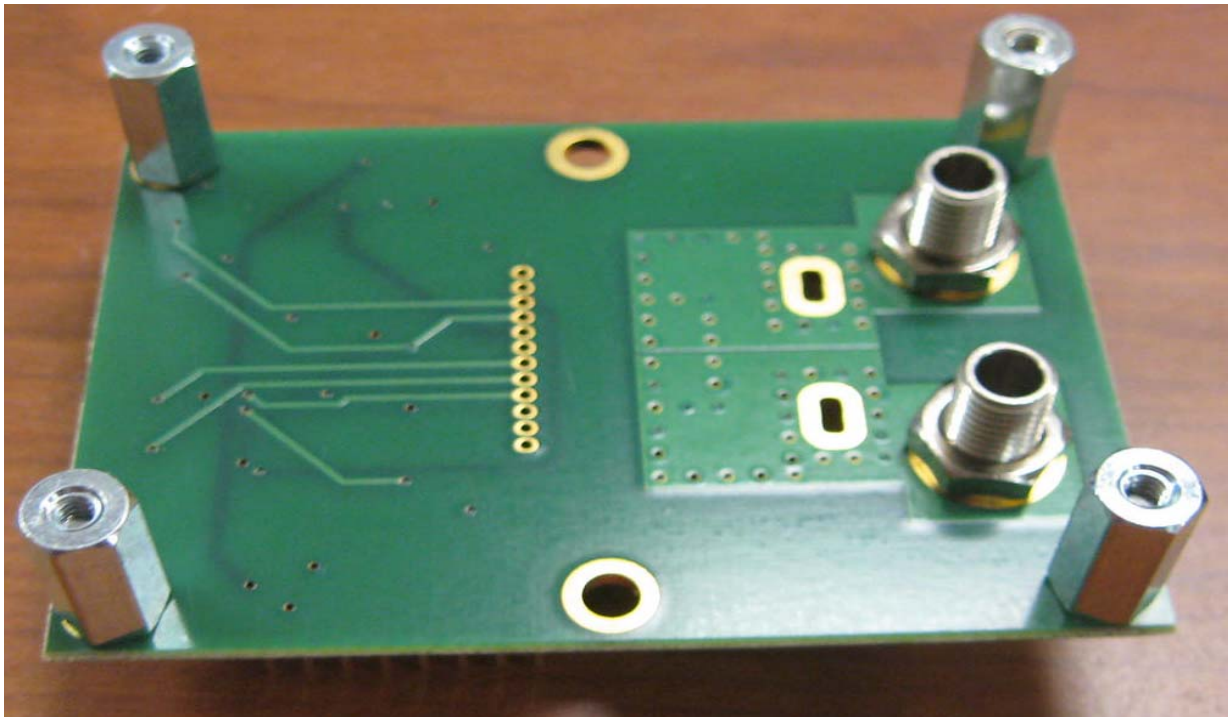

Originator: Shawn Upton

ITEM	QTY	S	Manufacturer	P/N	DESCRIPTION
1	2	6	AVX	06035A102JAT2A	capacitor, 0603, mono, C0G, 50V, 1nF
2	1	6	AVX	06035C103KAT2A	capacitor, 0603, mono, X7R, 50V, 10nF
3	1	6	AVX	06035C104K4T2A	capacitor, 0603, mono, X7R, 50V, 100nF
4	2	6	AVX	1206YD106KAT2A	capacitor, 1206, monolythic, 16V, X5R, 10uF
5	2				Do Not Install
6	1	6	Panasonic	ERJ-3EKF3010V	resistor, 0603, 100mW, thick film, 1%, 301ohm
7	1	6	Panasonic	ERJ-3EKF6340V	resistor, 0603, 100mW, thick film, 1%, 634ohm
8	1	6	Panasonic	ERJ-3EKF8250V	resistor, 0603, 100mW, thick film, 1%, 825ohm
9	5	6	Panasonic	ERJ-3EKF1001V	resistor, 0603, 100mW, thick film, 1%, 1.00kohm
10	3	6	Panasonic	ERJ-3EKF1002V	resistor, 0603, 100mW, thick film, 1%, 10.0kohm
11	1	6	Panasonic	ERJ-3EKF1783V	resistor, 0603, 100mW, thick film, 1%, 178kohm
12	2	6	Panasonic	ERJ-3EKF3323V	resistor, 0603, 100mW, thick film, 1%, 332kohm
13	3	6	Panasonic	ERJ-3GEY0R00V	jumper, 0603, zero ohm jumper
14	1				Do Not Install
15	1				Do Not Install
16	1	6	Panasonic	LNJ214R8ARA	LED, 0603, red
17	1	6	Diodes Inc	BSS84TA	transistor, sot-23, PFET, BSS84
18	1	6	Fairchild	LM317AEMP	IC, SOT-223, voltage regulator
19	1	10			
20	1	6	Molex	68301-1055	connector, SMT, 2 pin, straight header, gold
21	1	6	Molex	68301-1013	connector, SMT, 8 pin, straight header, gold
22	2	6	Emerson	111-2223-001	connector, thro, banana jack (5 way binding post)
23	1	6	Sullins	SSC02SYAN	jumper, 2 pin shunt, gold plating
24	2	6	Keystone Elec	5016	testpoint, SMT, larger
25	8	6	Keystone Elec	5015	testpoint, SMT, small
26	4	6	Keystone	1944	standoff, metal, hex threaded, male-female, 4-40 x 0.5in
27	4	6			nut, metal, zinc plated, hex, 4-40
28	1	10			PCB, as from 85-0444-001 Rev 2 gerber files

This BOM requires all components to be RoHS compliant; if parts substitution occurs, parts must be RoHS compliant.
All components must have RoHS certificates sent to Allegro for record keeping.

Originator: Shawn Upton

BOM Explanation

Item: each distinct component has a "line item" (but may span multiple lines). When questions arise to a component parameter/ to line item number first when inquiring.

QTY: the quantity of items to be ordered per finished assembly. Note: higher level documents may call this BOM multiple times
S: BOM Substitution Instructions. See below

Manufacturer: Recommended (or required) Manufacturer for the part(s). Note: multiple manufacturers may be listed per line item
Note: if no manufacturer part number is given, the the item is considered generic enough that that any manufacturer should be used.
P/N: The manufacturers part number. Note: if multiple manufacturers are listed, this P/N will correspond only to the manufacturer shown.

Note: Manufacturer part number may be incomplete; if not enough information is given, see below.
Description: this is a generic description of the part. Package size, part type, minimum/maximum requirements are listed.

Ref: This is the list of component designators.
If "see construction notes" is listed, the construction notes must be used to determine component location (not marked on PCB)
Note: surface mount components may have a designator listed but not marked on PCB silkscreen; if so then refer to -C

and/or the pick and place file (as found in the gerber files)
If a line item has multiple part numbers, they are not to be interpreted as any order of preference

If a line item has multiple part numbers, and the substitution code is 10, then only use parts as listed. Mixing is allowed (for example, 10, 10, 10)
listed, and qty is 5, then 2 parts may be from vendor A and 3 parts from vendor B)

BOM Substitution Notes:

The third column nomenclature is to be used for second sourcing components as follows:

1. Any substitution allowed, as long as mechanically identical
2. Any substitution allowed, as long as mechanically and electrically identical
3. Any substitution, as long as mechanically, electrically and visually identical
4. Any substitution allowed, as long as mechanically and visually identical and electrically similar
5. Any substitution allowed, as long as mechanically and visually similar and electrically identical
6. Any substitution allowed, as long as mechanically, electrically and visually similar
10. No substitution allowed.

"Identical" is to be interpreted as "meeting the same specifications" with no deviation from the stated specifications.

"Similar" is to be interpreted as "meeting or exceeding the stated specifications, in regards to electrical and/or mechanical parameters."
"Similar" as applied to visual means different colors may be used, unless otherwise noted. For example, an item with Substitution Code 4, 5, 6, 7, 8, 9, 10, 11, 12, 13, 14, 15, 16, 17, 18, 19, 20, 21, 22, 23, 24, 25, 26, 27, 28, 29, 30, 31, 32, 33, 34, 35, 36, 37, 38, 39, 40, 41, 42, 43, 44, 45, 46, 47, 48, 49, 50, 51, 52, 53, 54, 55, 56, 57, 58, 59, 60, 61, 62, 63, 64, 65, 66, 67, 68, 69, 70, 71, 72, 73, 74, 75, 76, 77, 78, 79, 80, 81, 82, 83, 84, 85, 86, 87, 88, 89, 90, 91, 92, 93, 94, 95, 96, 97, 98, 99, 100, 101, 102, 103, 104, 105, 106, 107, 108, 109, 110, 111, 112, 113, 114, 115, 116, 117, 118, 119, 120, 121, 122, 123, 124, 125, 126, 127, 128, 129, 130, 131, 132, 133, 134, 135, 136, 137, 138, 139, 140, 141, 142, 143, 144, 145, 146, 147, 148, 149, 150, 151, 152, 153, 154, 155, 156, 157, 158, 159, 160, 161, 162, 163, 164, 165, 166, 167, 168, 169, 170, 171, 172, 173, 174, 175, 176, 177, 178, 179, 180, 181, 182, 183, 184, 185, 186, 187, 188, 189, 190, 191, 192, 193, 194, 195, 196, 197, 198, 199, 200, 201, 202, 203, 204, 205, 206, 207, 208, 209, 210, 211, 212, 213, 214, 215, 216, 217, 218, 219, 220, 221, 222, 223, 224, 225, 226, 227, 228, 229, 230, 231, 232, 233, 234, 235, 236, 237, 238, 239, 240, 241, 242, 243, 244, 245, 246, 247, 248, 249, 250, 251, 252, 253, 254, 255, 256, 257, 258, 259, 260, 261, 262, 263, 264, 265, 266, 267, 268, 269, 270, 271, 272, 273, 274, 275, 276, 277, 278, 279, 280, 281, 282, 283, 284, 285, 286, 287, 288, 289, 290, 291, 292, 293, 294, 295, 296, 297, 298, 299, 300, 301, 302, 303, 304, 305, 306, 307, 308, 309, 310, 311, 312, 313, 314, 315, 316, 317, 318, 319, 320, 321, 322, 323, 324, 325, 326, 327, 328, 329, 330, 331, 332, 333, 334, 335, 336, 337, 338, 339, 340, 341, 342, 343, 344, 345, 346, 347, 348, 349, 350, 351, 352, 353, 354, 355, 356, 357, 358, 359, 360, 361, 362, 363, 364, 365, 366, 367, 368, 369, 370, 371, 372, 373, 374, 375, 376, 377, 378, 379, 380, 381, 382, 383, 384, 385, 386, 387, 388, 389, 390, 391, 392, 393, 394, 395, 396, 397, 398, 399, 400, 401, 402, 403, 404, 405, 406, 407, 408, 409, 410, 411, 412, 413, 414, 415, 416, 417, 418, 419, 420, 421, 422, 423, 424, 425, 426, 427, 428, 429, 430, 431, 432, 433, 434, 435, 436, 437, 438, 439, 440, 441, 442, 443, 444, 445, 446, 447, 448, 449, 450, 451, 452, 453, 454, 455, 456, 457, 458, 459, 460, 461, 462, 463, 464, 465, 466, 467, 468, 469, 470, 471, 472, 473, 474, 475, 476, 477, 478, 479, 480, 481, 482, 483, 484, 485, 486, 487, 488, 489, 490, 491, 492, 493, 494, 495, 496, 497, 498, 499, 500, 501, 502, 503, 504, 505, 506, 507, 508, 509, 510, 511, 512, 513, 514, 515, 516, 517, 518, 519, 520, 521, 522, 523, 524, 525, 526, 527, 528, 529, 530, 531, 532, 533, 534, 535, 536, 537, 538, 539, 540, 541, 542, 543, 544, 545, 546, 547, 548, 549, 550, 551, 552, 553, 554, 555, 556, 557, 558, 559, 560, 561, 562, 563, 564, 565, 566, 567, 568, 569, 570, 571, 572, 573, 574, 575, 576, 577, 578, 579, 580, 581, 582, 583, 584, 585, 586, 587, 588, 589, 590, 591, 592, 593, 594, 595, 596, 597, 598, 599, 600, 601, 602, 603, 604, 605, 606, 607, 608, 609, 610, 611, 612, 613, 614, 615, 616, 617, 618, 619, 620, 621, 622, 623, 624, 625, 626, 627, 628, 629, 630, 631, 632, 633, 634, 635, 636, 637, 638, 639, 640, 641, 642, 643, 644, 645, 646, 647, 648, 649, 650, 651, 652, 653, 654, 655, 656, 657, 658, 659, 660, 661, 662, 663, 664, 665, 666, 667, 668, 669, 670, 671, 672, 673, 674, 675, 676, 677, 678, 679, 680, 681, 682, 683, 684, 685, 686, 687, 688, 689, 690, 691, 692, 693, 694, 695, 696, 697, 698, 699, 700, 701, 702, 703, 704, 705, 706, 707, 708, 709, 710, 711, 712, 713, 714, 715, 716, 717, 718, 719, 720, 721, 722, 723, 724, 725, 726, 727, 728, 729, 730, 731, 732, 733, 734, 735, 736, 737, 738, 739, 740, 741, 742, 743, 744, 745, 746, 747, 748, 749, 750, 751, 752, 753, 754, 755, 756, 757, 758, 759, 760, 761, 762, 763, 764, 765, 766, 767, 768, 769, 770, 771, 772, 773, 774, 775, 776, 777, 778, 779, 780, 781, 782, 783, 784, 785, 786, 787, 788, 789, 790, 791, 792, 793, 794, 795, 796, 797, 798, 799, 800, 801, 802, 803, 804, 805, 806, 807, 808, 809, 810, 811, 812, 813, 814, 815, 816, 817, 818, 819, 820, 821, 822, 823, 824, 825, 826, 827, 828, 829, 830, 831, 832, 833, 834, 835, 836, 837, 838, 839, 840, 841, 842, 843, 844, 845, 846, 847, 848, 849, 850, 851, 852, 853, 854, 855, 856, 857, 858, 859, 860, 861, 862, 863, 864, 865, 866, 867, 868, 869, 870, 871, 872, 873, 874, 875, 876, 877, 878, 879, 880, 881, 882, 883, 884, 885, 886, 887, 888, 889, 890, 891, 892, 893, 894, 895, 896, 897, 898, 899, 900, 901, 902, 903, 904, 905, 906, 907, 908, 909, 910, 911, 912, 913, 914, 915, 916, 917, 918, 919, 920, 921, 922, 923, 924, 925, 926, 927, 928, 929, 930, 931, 932, 933, 934, 935, 936, 937, 938, 939, 940, 941, 942, 943, 944, 945, 946, 947, 948, 949, 950, 951, 952, 953, 954, 955, 956, 957, 958, 959, 960, 961, 962, 963, 964, 965, 966, 967, 968, 969, 970, 971, 972, 973, 974, 975, 976, 977, 978, 979, 980, 981, 982, 983, 984, 985, 986, 987, 988, 989, 990, 991, 992, 993, 994, 995, 996, 997, 998, 999, 1000, 1001, 1002, 1003, 1004, 1005, 1006, 1007, 1008, 1009, 1010, 1011, 1012, 1013, 1014, 1015, 1016, 1017, 1018, 1019, 1020, 1021, 1022, 1023, 1024, 1025, 1026, 1027, 1028, 1029, 1030, 1031, 1032, 1033, 1034, 1035, 1036, 1037, 1038, 1039, 1040, 1041, 1042, 1043, 1044, 1045, 1046, 1047, 1048, 1049, 1050, 1051, 1052, 1053, 1054, 1055, 1056, 1057, 1058, 1059, 1060, 1061, 1062, 1063, 1064, 1065, 1066, 1067, 1068, 1069, 1070, 1071, 1072, 1073, 1074, 1075, 1076, 1077, 1078, 1079, 1080, 1081, 1082, 1083, 1084, 1085, 1086, 1087, 1088, 1089, 1090, 1091, 1092, 1093, 1094, 1095, 1096, 1097, 1098, 1099, 1100, 1101, 1102, 1103, 1104, 1105, 1106, 1107, 1108, 1109, 1110, 1111, 1112, 1113, 1114, 1115, 1116, 1117, 1118, 1119, 1120, 1121, 1122, 1123, 1124, 1125, 1126, 1127, 1128, 1129, 1130, 1131, 1132, 1133, 1134, 1135, 1136, 1137, 1138, 1139, 1140, 1141, 1142, 1143, 1144, 1145, 1146, 1147, 1148, 1149, 1150, 1151, 1152, 1153, 1154, 1155, 1156, 1157, 1158, 1159, 1160, 1161, 1162, 1163, 1164, 1165, 1166, 1167, 1168, 1169, 1170, 1171, 1172, 1173, 1174, 1175, 1176, 1177, 1178, 1179, 1180, 1181, 1182, 1183, 1184, 1185, 1186, 1187, 1188, 1189, 1190, 1191, 1192, 1193, 1194, 1195, 1196, 1197, 1198, 1199, 1200, 1201, 1202, 1203, 1204, 1205, 1206, 1207, 1208, 1209, 1210, 1211, 1212, 1213, 1214, 1215, 1216, 1217, 1218, 1219, 1220, 1221, 1222, 1223, 1224, 1225, 1226, 1227, 1228, 1229, 1230, 1231, 1232, 1233, 1234, 1235, 1236, 1237, 1238, 1239, 1240, 1241, 1242, 1243, 1244, 1245, 1246, 1247, 1248, 1249, 1250, 1251, 1252, 1253, 1254, 1255, 1256, 1257, 1258, 1259, 1260, 1261, 1262, 1263, 1264, 1265, 1266, 1267, 1268, 1269, 1270, 1271, 1272, 1273, 1274, 1275, 1276, 1277, 1278, 1279, 1280, 1281, 1282, 1283, 1284, 1285, 1286, 1287, 1288, 1289, 1290, 1291, 1292, 1293, 1294, 1295, 1296, 1297, 1298, 1299, 1300, 1301, 1302, 1303, 1304, 1305, 1306, 1307, 1308, 1309, 1310, 1311, 1312, 1313, 1314, 1315, 1316, 1317, 1318, 1319, 1320, 1321, 1322, 1323, 1324, 1325, 1326, 1327, 1328, 1329, 1330, 1331, 1332, 1333, 1334, 1335, 1336, 1337, 1338, 1339, 1340, 1341, 1342, 1343, 1344, 1345, 1346, 1347, 1348, 1349, 1350, 1351, 1352, 1353, 1354, 1355, 1356, 1357, 1358, 1359, 1360, 1361, 1362, 1363, 1364, 1365, 1366, 1367, 1368, 1369, 1370, 1371, 1372, 1373, 1374, 1375, 1376, 1377, 1378, 1379, 1380, 1381, 1382, 1383, 1384, 1385, 1386, 1387, 1388, 1389, 1390, 1391, 1392, 1393, 1394, 1395, 1396, 1397, 1398, 1399, 1400, 1401, 1402, 1403, 1404, 1405, 1406, 1407, 1408, 1409, 1410, 1411, 1412, 1413, 1414, 1415, 1416, 1417, 1418, 1419, 1420, 1421, 1422, 1423, 1424, 1425, 1426, 1427, 1428, 1429, 1430, 1431, 1432, 1433, 1434, 1435, 1436, 1437, 1438, 1439, 1440, 1441, 1442, 1443, 1444, 1445, 1446, 1447, 1448, 1449, 1450, 1451, 1452, 1453, 1454, 1455, 1456, 1457, 1458, 1459, 1460, 1461, 1462, 1463, 1464, 1465, 1466, 1467, 1468, 1469, 1470, 1471, 1472, 1473, 1474, 1475, 1476, 1477, 1478, 1479, 1480, 1481, 1482, 1483, 1484, 1485, 1486, 1487, 1488, 1489, 1490, 1491, 1492, 1493, 1494, 1495, 1496, 1497, 1498, 1499, 1500, 1501, 1502, 1503, 1504, 1505, 1506, 1507, 1508, 1509, 1510, 1511, 1512, 1513, 1514, 1515, 1516, 1517, 1518, 1519, 1520, 1521, 1522, 1523, 1524, 1525, 1526, 1527, 1528, 1529, 1530, 1531, 1532, 1533, 1534, 1535, 1536, 1537, 1538, 1539, 1540, 1541, 1542, 1543, 1544, 1545, 1546, 1547, 1548, 1549, 1550, 1551, 1552, 1553, 1554, 1555, 1556, 1557, 1558, 1559, 1560, 1561, 1562, 1563, 1564, 1565, 1566, 1567, 1568, 1569, 1570, 1571, 1572, 1573, 1574, 1575, 1576, 1577, 1578, 1579, 1580, 1581, 1582, 1583, 1584, 1585, 1586, 1587, 1588, 1589, 1590, 1591, 1592, 1593, 1594, 1595, 1596, 1597, 1598, 1599, 1600, 1601, 1602, 1603, 1604, 1605, 1606, 1607, 1608, 1609, 1610, 1611, 1612, 1613, 1614, 1615, 1616, 1617, 1618, 1619, 1620, 1621, 1622, 1623, 1624, 1625, 1626, 1627, 1628, 1629, 1630, 1631, 1632, 1633, 1634, 1635, 1636, 1637, 1638, 1639, 1640, 1641, 1642, 1643, 1644, 1645, 1646, 1647, 1648, 1649, 1650, 1651, 1652, 1653, 1654, 1655, 1656, 1657, 1658, 1659, 1660, 1661, 1662, 1663, 1664, 1665, 1666, 1667, 1668, 1669, 1670, 1671, 1672, 1673, 1674, 1675, 1676, 1677, 1678, 1679, 1680, 1681, 1682, 1683, 1684, 1685, 1686, 1687, 1688, 1689, 1690, 1691, 1692, 1693, 1694, 1695, 1696, 1697, 1698, 1699, 1700, 1701, 1702, 1703, 1704, 1705, 1706, 1707, 1708, 1709, 1710, 1711, 1712, 1713, 1714, 1715, 1716, 1717, 1718, 1719, 1720, 1721, 1722, 1723, 1724, 1725, 1726, 1727, 1728, 1729, 1730, 1731, 1732, 1733, 1734, 1735, 1736, 1737, 1738, 1739, 1740, 1741, 1742, 1743, 1744, 1745, 1746, 1747, 1748, 1749, 1750, 1751, 1752, 1753, 1754, 1755, 1756, 1757, 1758, 1759, 1760, 1761, 1762, 1763, 1764, 1765, 1766, 1767, 1768, 1769, 1770, 1771, 1772, 1773, 1774, 1775, 1776, 1777, 1778, 1779, 1780, 1781, 1782, 1783, 1784, 1785, 1786, 1787, 1788, 1789, 1790, 1791, 1792, 1793, 1794, 1795, 1796, 1797, 1798, 1799, 1800, 1801, 1802, 1803, 1804, 1805, 1806, 1807, 1808, 1809, 1810, 1811, 1812, 1813, 1814, 1815, 1816, 1817, 1818, 1819, 1820, 1821, 1822, 1823, 1824, 1825, 1826, 1827, 1828, 1829, 1830, 1831, 1832, 1833, 1834, 1835, 1836, 1837, 1838, 1839, 1840, 1841, 1842, 1843, 1844, 1845, 1846, 1847, 1848, 1849, 1850, 1851, 1852, 1853, 1854, 1855, 1856, 1857, 1858, 1859, 1860, 1861, 1862, 1863, 1864, 1865, 1866, 1867, 1868, 1869, 1870, 1871, 1872, 1873, 1874, 1875, 1876, 1877, 1878, 1879, 1880, 1881, 1882, 1883, 1884, 1885, 1886, 1887, 1888, 1889, 1890, 1891, 1892, 1893, 1894, 1895, 1896, 1897, 1898, 1899, 1900, 1901, 1902, 1903, 1904, 1905, 1906, 1907, 1908, 1909, 1910, 1911, 1912, 1913, 1914, 1915, 1916, 1917, 1918, 1919, 1920, 1921, 1922, 1923, 1924, 1925, 1926, 1927, 1928, 1929, 1930, 1931, 1932, 1933, 1934, 1935, 1936, 1937, 1938, 1939, 1940, 1941, 1942, 1943, 1944, 1945, 1946, 1947, 1948, 1949, 1950, 1951, 1952, 1953, 1954, 1955, 1956, 1957, 1958, 1959, 1960, 1961, 1962, 1963, 1964, 1965, 1966, 1967, 1968, 1969, 1970, 1971, 1972, 1973, 1974, 1975, 1976, 1977, 1978, 1979, 1980, 1981, 1982, 1983, 1984, 1985, 1986, 1987, 1988, 1989, 1990, 1991, 1992, 1993, 1994, 1995, 1996, 1997, 1998, 1999, 2000, 2001, 2002, 2003, 2004, 2005, 2006, 2007, 2008, 2009, 2010, 2011, 2012, 2013, 2014, 2015, 2016, 2017, 2018, 2019, 2020, 2021, 2022, 2023, 2024, 2025, 2026, 2027, 2028, 2029, 2030, 2031, 2032, 2033, 2034, 2035, 2036, 2037, 2038, 2039, 2040, 2041, 2042, 2043, 2044, 2045, 2046, 2047, 2048, 2049, 2050, 2051, 2052, 2053, 2054, 2055, 2056,

Originator: Shawn Upton

- unless otherwise stated, capacitance value must be identical
- unless otherwise stated, lead spacing and external dimensions must be the same
- unless otherwise stated, height must be the same.

Resistors:

- tempco must same or go down
 - tolerance must be same or go down
 - unless otherwise stated, resistance value must be identical
- Note: when going from 5% to 1%, use nearest value size
- power dissipation must be same or greater
 - unless otherwise stated, package size must be the same
 - unless otherwise stated, coloring and marking can vary

Diodes and Transistors:

- unless otherwise stated, package size must be the same
- IC's, Connectors, and all other parts::
- unless otherwise stated, package size must be the same (DIP16, SOIC-8, etc)

Manufacturer Part Number Discrepancies

Every attempt will be made to provide a workable part number. However, prefixes and suffixes can vary over time. If second sourcing from a different manufacturer, make sure that the requirements as noted under the Description column are met. In general, if temperature option(s) are not noted, parts specified to work from 0-85C will be sufficient. If package information is not given, please check the description for package type.

Any and all discrepancies should be reported to Allegro MicroSystems for correction and updates.

A

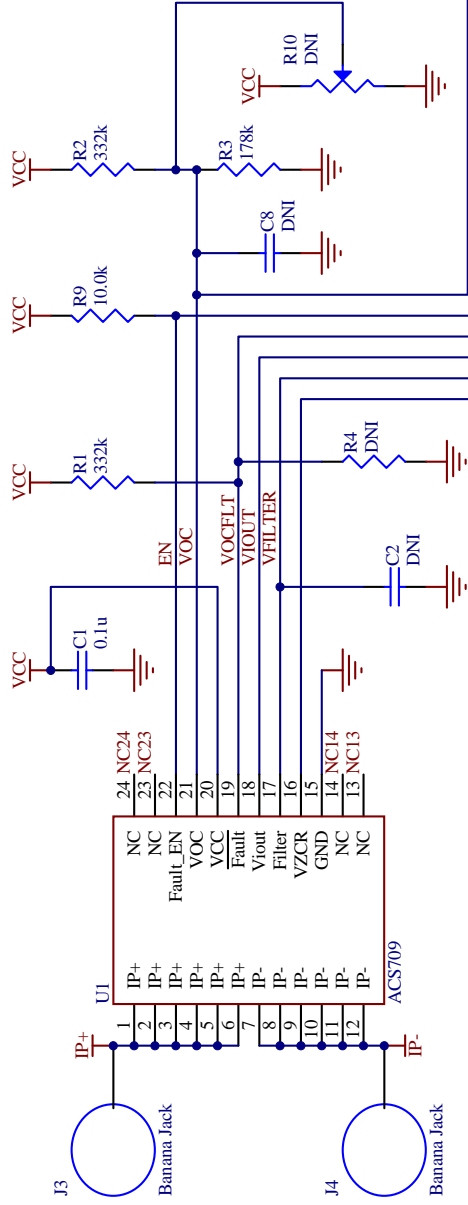

B

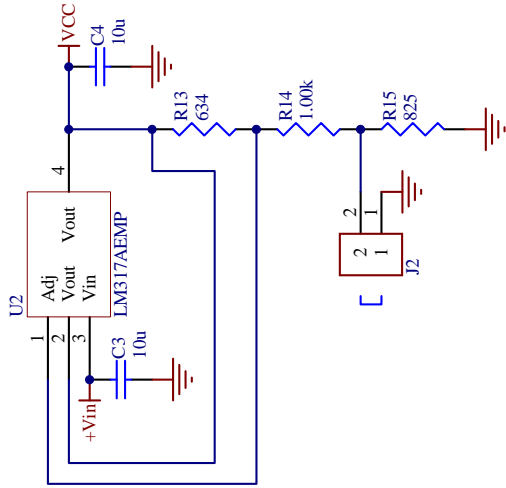

C

Install J2 for VCC=3.3V, otherwise VCC=5V

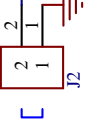

D

- 4-40nut
- 4-40nut
- 4-40nut
- 4-40nut
- 4-40 MF hex threaded 0.5" standoff
- 4-40 MF hex threaded 0.5" standoff
- 4-40 MF hex threaded 0.5" standoff
- 4-40 MF hex threaded 0.5" standoff

Title: ACS709 Demo Board	
Size: A	Number: 85-0444-0
Date: 9/23/2011	Author: Shawn Up
File: 85-0444-001 Rev 1.SchDoc	Time: 1:2:

ACS709 Demo Board
85-0444-100-BOM

ASEK709LLF-35B-T
Bill of Materials

Originator: Shawn Upton

Page 1 of 1

ITEM	QTY	S	Manufacturer	P/N	DESCRIPTION
1	1	10	Allegro	85-0444-001	Bare Board Assembly, no sensor
2	1	10	Allegro	ACS709LLF-35BB-T	current sensor
					U1

This BOM requires all components to be RoHS compliant; if parts substitution occurs, parts must be RoHS compliant.
All components must have RoHS certificates sent to Allegro for record keeping.

ACS709 Demo Board
85-0444-101-BOM

ASEK709LLF-20B-T
Bill of Materials

Originator: Shawn Upton

Page 1 of 1

ITEM	QTY	S	Manufacturer	P/N	DESCRIPTION
1	1	10	Allegro	85-0444-001	Bare Board Assembly, no sensor
2	1	10	Allegro	ACS709LLF-20BB-T	current sensor
					U1

This BOM requires all components to be RoHS compliant; if parts substitution occurs, parts must be RoHS compliant.
All components must have RoHS certificates sent to Allegro for record keeping.

Looking for pricing, stock, or lifecycle information?

Click below to explore more details on WIN SOURCE:

- ⊖ [View ASEK709LLF-35BB-T-DK on WIN SOURCE](#)
- ⊖ [Allegro MicroSystems, LLC Information](#)

Optimize Your Supply Chain with WIN SOURCE Solutions

- ✓ Global Sourcing Solution
- ✓ Obsolete Management
- ✓ Cost Control Management
- ✓ Shortage Management
- ✓ Alternative Solution
- ✓ Excess Inventory Management