



**THE DATASHEET OF  
ASEK37612-BUSBAR-DK**



## ACS37612 Evaluation Kit User Guide

### INTRODUCTION

This user guide documents the features, operation, and use of the ACS37612 current sensor with the ASEK37612 evaluation kit. Allegro MicroSystems offers evaluation kit units that offer a method for quickly evaluating the Allegro current sensor in a lab environment without the need for a custom circuit board.

The evaluation kit is used to evaluate the functionality of the ACS37612, an economical and precise solution for AC and DC current sensing in busbar and high-current PCB (printed circuit board) applications. Applied current through a busbar or PCB generates a magnetic field that is sensed by the Hall IC. The ACS37612 outputs an analog signal that varies linearly with the field sensed within the range specified. Differential sensing topology virtually eliminates error from common-mode stray magnetic fields. High isolation is achieved via the no-contact nature of this assembly.

This guide includes a schematic of the ASEK37612 evaluation board (EVB), reference documentation, measurement and operation techniques, printed circuit board (PCB)

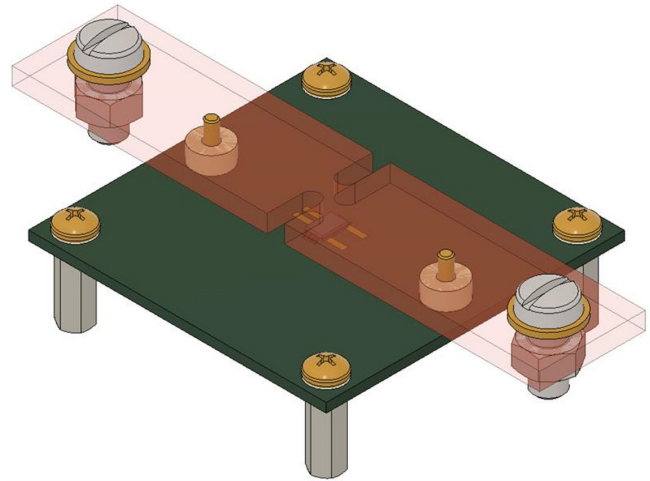

**Figure 1: ASEK37612 Evaluation Kit**

layouts, and a bill of materials (BOM). The table below includes the maximum current, coupling factor, differential field, and IC sensitivity for each PCB application.

**Table 1: Current range based on reference PCB design**

PCB Application [1]	Maximum Current (A) [2]	Coupling Factor (G/A)	Differential Field (G)	IC Sensitivity (mV/G)
5 Layers – Reference Design 3.5 mm – 015B5	±190	0.74	±133	15
5 Layers – Reference Design 3.5 mm – 010B5	±270	0.74	±200	10
5 Layers – Reference Design 4.5 mm – 015B5	±235	0.57	±133	15
5 Layers – Reference Design 4.5 mm – 010B5	±350	0.57	±200	10
5 Layers – Reference Design 7 mm – 015B5	±500	0.265	±133	15
5 Layers – Reference Design 7 mm – 010B5	±750	0.265	±200	10

[1] Maximum continuous current without proper cooling on these PCB designs should not exceed 200 A.

[2] Full-scale current is required to cover the full-scale output range (bidirectional = ±2 V).

### Table of Contents

Introduction .....	1	Thermal Consequence of a Notched Busbar .....	11
Selection Guide and Packaging .....	2	Common Measurements .....	12
Related Documentation .....	3	Evaluation Board Connections .....	12
ASEK37612 Complete Assembly .....	4	Busbar Dimensions .....	13
Layout .....	5	Busbar Design Recommendations .....	14
Thermal Limitations .....	6	Relationship Between Coupling Factor and Air Gap .....	15
Busbar and Spacer Characteristics .....	7	Calculating Full-Scale Current Range Using CF and IC Sensitivity .....	16
Schematic .....	8	PCB Sensing – Typical Application .....	16
Application Information .....	8	Components .....	17
Functional Description and Theory of Operation .....	8	Schematic .....	18
Assembly – PCB .....	9	Bill of Materials .....	18
Assembly – Reference Busbar .....	10	Revision History .....	19
Typical Application – Busbar Sensing .....	11		

## SELECTION GUIDE AND PACKAGING

The ACS37612 is provided in a small, low-profile 8-pin surface mount TSSOP package, making the ACS37612 an ideal sensor for space-constrained applications, while still allowing simple assembly. The TSSOP-8 package is lead (Pb) free with 100% matte tin leadframe plating.

Several gain options are available for the ACS37612. These options are listed in Table 3 below. The naming specification can be seen below in Figure 3. These devices operate from a 3.3 V or 5 V power supply, drawing a maximum of 17 mA of supply current.

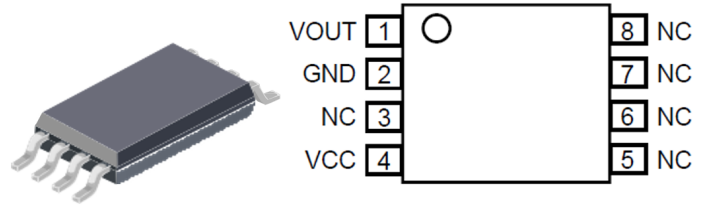

Figure 2: Package LU, 8-Pin TSSOP

Table 2: ACS37612 Pinout Description

Number	Name	Function
1	VOUT	Output signal
2	GND	Signal ground terminal
3, 5, 6, 7, 8	NC	Not connected; tie to GND for better ESD performance
4	VCC	Device power supply terminal

Table 3: ACS37612 Selection Guide

Part Number	Differential Magnetic Input Range, (G)	Sensitivity Sens (Typ.) (mV/G) <sup>[1]</sup>	Nominal Supply Voltage (V)	Bandwidth (kHz)	T <sub>A</sub> (°C)	Packing <sup>[2]</sup>
ACS37612LLUATR-005B5	±400	5	5	140	-40 to 150	4000 pieces per 13-inch reel
ACS37612LLUATR-010B3	±135	10	3.3			
ACS37612LLUATR-010B5	±200	10	5			
ACS37612LLUATR-015B5	±130	15	5			
ACS37612LLUATR-015U5	0 to 265	15	5			

<sup>[1]</sup> Measured at nominal supply voltage. Contact Allegro for other sensitivity options.

<sup>[2]</sup> Contact Allegro for additional packing options.

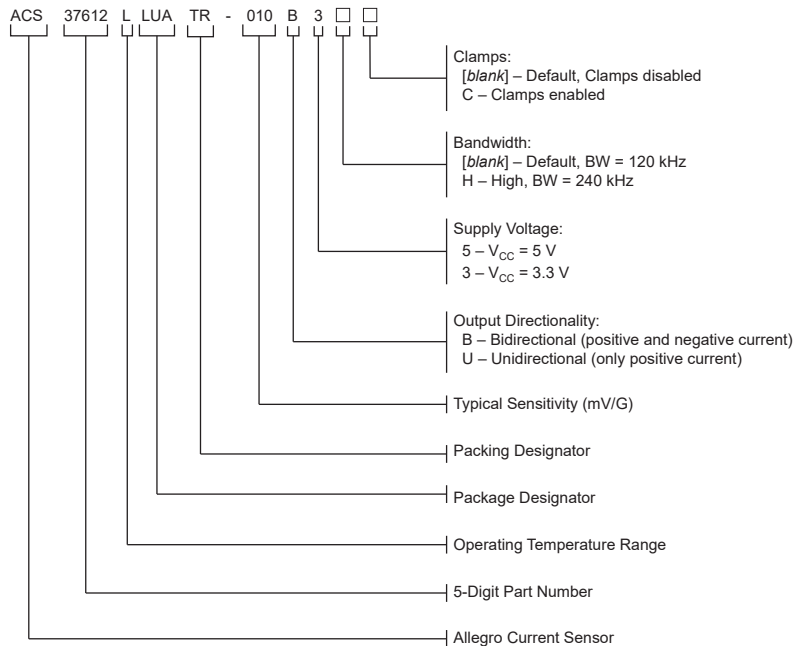

Figure 3: ACS37612 Naming Specification

## RELATED DOCUMENTATION

Application notes and related information for the ACS37612 is available. Descriptions and locations for related documentation is listed in the table below.

**Table 4: Related Documentation and Application Notes**

Documentation	Summary	Location
ACS37612 Datasheet	Product datasheet defining common electrical characteristics and performance characteristics	<a href="https://www.allegromicro.com/en/products/sense/current-sensor-ics/sip-package-zero-to-thousand-amp-sensor-ics/acs37612">https://www.allegromicro.com/en/products/sense/current-sensor-ics/sip-package-zero-to-thousand-amp-sensor-ics/acs37612</a>
ACS37612 Purchasing	Purchasing homepage	<a href="https://www.allegromicro.com/en/products/sense/current-sensor-ics/sip-package-zero-to-thousand-amp-sensor-ics/acs37612">https://www.allegromicro.com/en/products/sense/current-sensor-ics/sip-package-zero-to-thousand-amp-sensor-ics/acs37612</a>
ACS37612 Gerber Files	Schematic files containing evaluation board layers	<a href="https://allegromicro.com/en/products/sense/current-sensor-ics/sip-package-zero-to-thousand-amp-sensor-ics/acs37612">https://allegromicro.com/en/products/sense/current-sensor-ics/sip-package-zero-to-thousand-amp-sensor-ics/acs37612</a>
ACS37612 Samples Programmer Software	Programming software for download	<a href="https://registration.allegromicro.com/login">https://registration.allegromicro.com/login</a>
ACS37612 Samples Programmer Quick Guide	Quick guide documenting the programming calibration procedure for the ACS37612	TBD
Allegro ACS37612 Busbar Calculator	GUI designed to aid in busbar design and application	<a href="https://allegromicro.com/busbar/">https://allegromicro.com/busbar/</a>
Guidelines For Designing a Busbar with Notch for Allegro's Coreless ACS37612 Differential Current Sensor	Application note discussing busbar design and geometry	<a href="https://allegromicro.com/-/media/allegro/allegromicro/files/application-notes/an296188-acs37612-guidelines-for-designing-a-busbar-web.ashx?la=en&amp;hash=0989AAF10F84A4D1D6571C094D487A13FE4B87A4">https://allegromicro.com/-/media/allegro/allegromicro/files/application-notes/an296188-acs37612-guidelines-for-designing-a-busbar-web.ashx?la=en&amp;hash=0989AAF10F84A4D1D6571C094D487A13FE4B87A4</a>
An Effective Method for Characterizing System Bandwidth in Complex Current Sensor Applications	Application note describing methods used by Allegro to measure and quantify system bandwidth	<a href="https://allegromicro.com/en/insights-and-innovations/technical-documents/hall-effect-sensor-ic-publications/an%20effective%20method%20for%20characterizing%20system%20bandwidth-an296169">https://allegromicro.com/en/insights-and-innovations/technical-documents/hall-effect-sensor-ic-publications/an%20effective%20method%20for%20characterizing%20system%20bandwidth-an296169</a>
High-Current Measurement with Allegro Current Sensor IC and Ferromagnetic Core: Impact of Eddy Currents	Application note focusing on the effects of alternating current on current measurement	<a href="https://allegromicro.com/en/insights-and-innovations/technical-documents/hall-effect-sensor-ic-publications/an296162_a1367_current-sensor-eddy-current-core">https://allegromicro.com/en/insights-and-innovations/technical-documents/hall-effect-sensor-ic-publications/an296162_a1367_current-sensor-eddy-current-core</a>
Allegro Hall-Effect Sensor ICs	Application note describing Hall-effect principles	<a href="https://allegromicro.com/en/insights-and-innovations/technical-documents/hall-effect-sensor-ic-publications/allegro-hall-effect-sensor-ics">https://allegromicro.com/en/insights-and-innovations/technical-documents/hall-effect-sensor-ic-publications/allegro-hall-effect-sensor-ics</a>
Hall-Effect Current Sensing in Electric and Hybrid Vehicles	Application note providing a greater understanding of hybrid electric vehicles and the contribution of Hall-effect sensing technology	<a href="https://allegromicro.com/en/insights-and-innovations/technical-documents/hall-effect-sensor-ic-publications/hall-effect-current-sensing-in-electric-and-hybrid-vehicles">https://allegromicro.com/en/insights-and-innovations/technical-documents/hall-effect-sensor-ic-publications/hall-effect-current-sensing-in-electric-and-hybrid-vehicles</a>
Hall-Effect Current Sensing in Hybrid Electric Vehicle (HEV) Applications	Application note providing a greater understanding of hybrid electric vehicles and the contribution of Hall-effect sensing technology	<a href="https://allegromicro.com/en/insights-and-innovations/technical-documents/hall-effect-sensor-ic-publications/hall-effect-current-sensing-in-hybrid-electric-vehicle-hev-applications">https://allegromicro.com/en/insights-and-innovations/technical-documents/hall-effect-sensor-ic-publications/hall-effect-current-sensing-in-hybrid-electric-vehicle-hev-applications</a>
Achieving Closed-Loop Accuracy in Open-Loop Current Sensors	Application note regarding current sensor IC solutions that achieve near closed-loop accuracy using open-loop topology	<a href="https://allegromicro.com/en/insights-and-innovations/technical-documents/hall-effect-sensor-ic-publications/achieving%20closed-loop%20accuracy%20in%20open-loop%20current%20sensors">https://allegromicro.com/en/insights-and-innovations/technical-documents/hall-effect-sensor-ic-publications/achieving%20closed-loop%20accuracy%20in%20open-loop%20current%20sensors</a>

## ASEK37612 COMPLETE ASSEMBLY

An exploded view of the complete ASEK37612 evaluation kit is shown in Figure 4. See the Bill of Materials section below.

The ASEK37612 includes:

1. Current busbar
2. Busbar standoffs
3. Current connection screws
4. Washer
5. Nut
6. Busbar mounting screws
7. Standoff mounting screw
8. PCB standoff

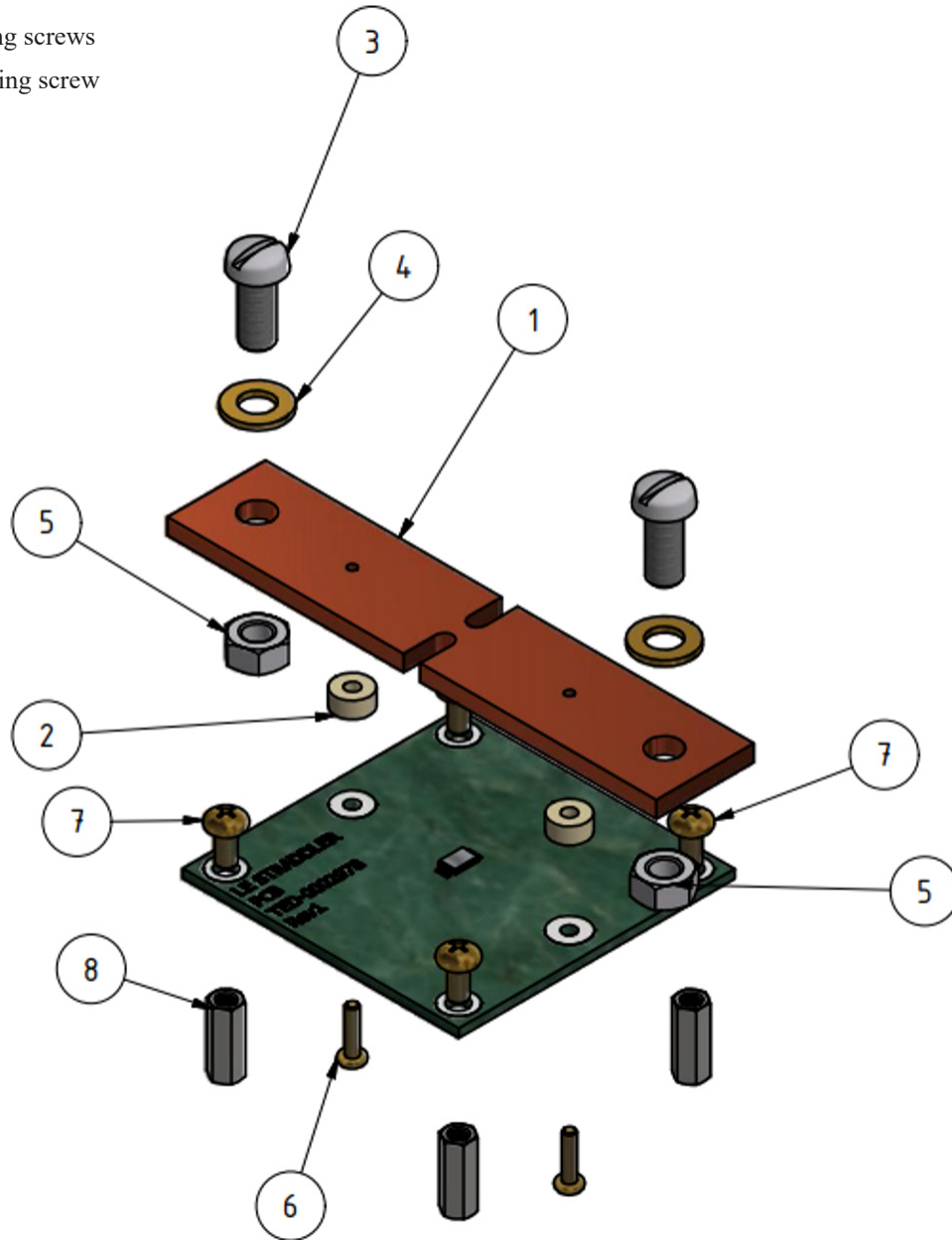

Figure 4: Exploded View of ASEK37612 Evaluation Kit Components

## Layout

The ASEK37612 PCB consists of two layers; top and bottom layers can be seen in Figure 5 below. The ASEK37612 PCB includes:

1. Footprint for 8-Pin TSSOP
2. Holes for mounting the busbar
3. Header for wiring harness
4. Test points for fast connections
5. Test points ground for scope clips

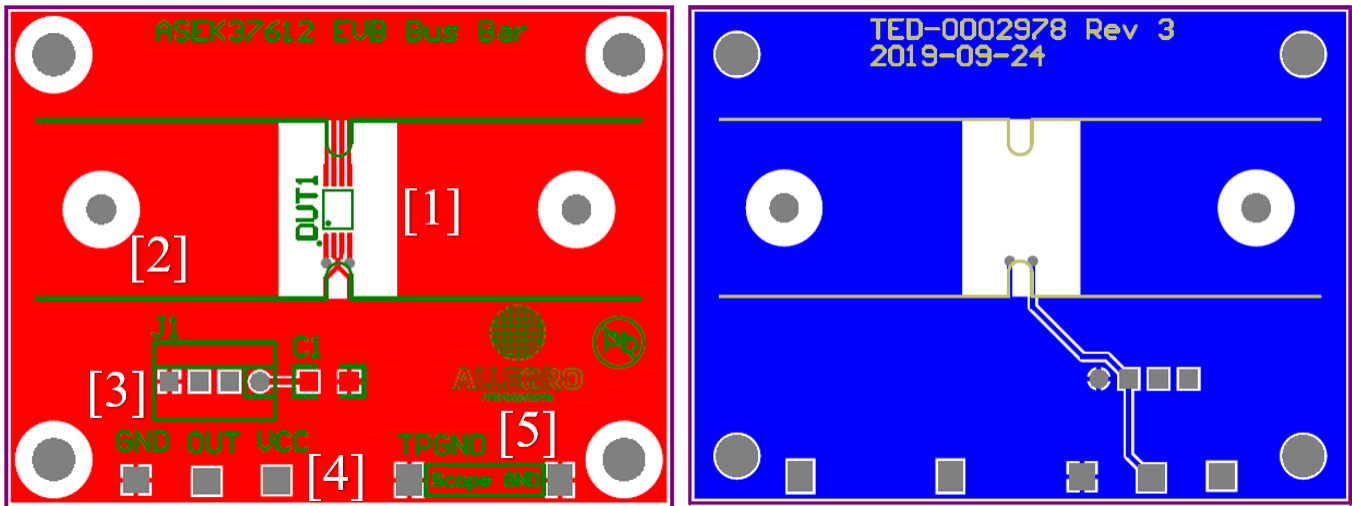

Figure 5: ASEK37612 PCB Top (left) and Bottom Layers (right)

The ASEK37612 evaluation board includes a reference busbar. See Figure 6 below showing the reference busbar [1] with busbar mounting screws [2] and current connection screws [3].

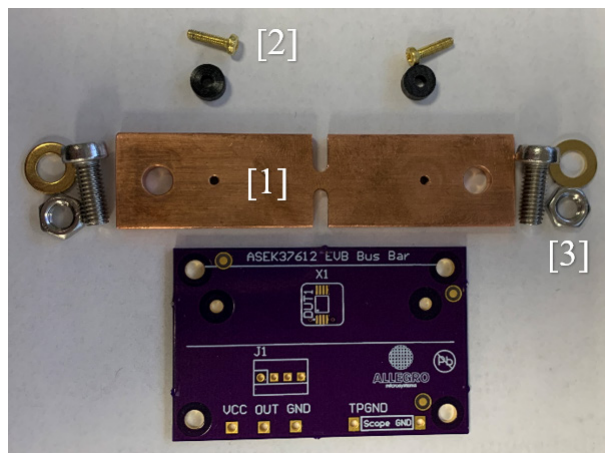

Figure 6: Printed Evaluation Board with Reference Busbar

## Thermal Limitations

Self-heating due to the flow of current should be considered during the design of any current sensing system. The sensor, the printed circuit board (PCB), and contacts to the PCB will generate heat as current moves through the system. The thermal response is highly dependent on PCB layout, copper thickness, cooling techniques, and the profile of the injected current. Figure 7 below shows the measured rise in steady-state die temperature of the ASEK37612 versus continuous current at an ambient temperature  $T_A = 25^\circ\text{C}$ . The thermal offset curves may be directly applied to other ambient temperatures. Figure 8 below shows the maximum continuous current at a given  $T_A$ . Surges beyond the maximum junction are allowed given the maximum junction temperature,  $T_{J(\text{MAX})}$  ( $165^\circ\text{C}$ ), is not exceeded. The maximum continuous current rating of the ASEK37612 evaluation boards is 200 A  $\pm 3\%$ .

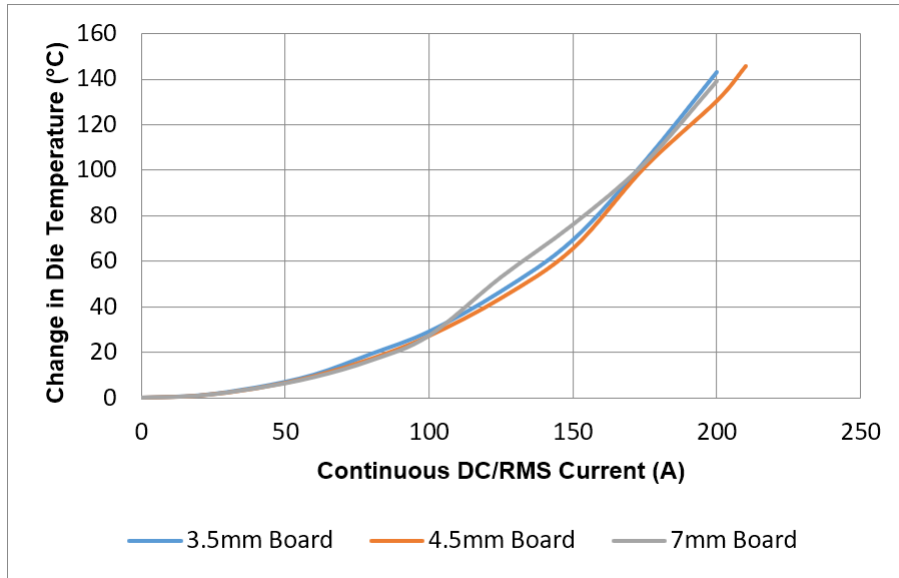

Figure 7: Continuous Current vs. Change in Die Temperature

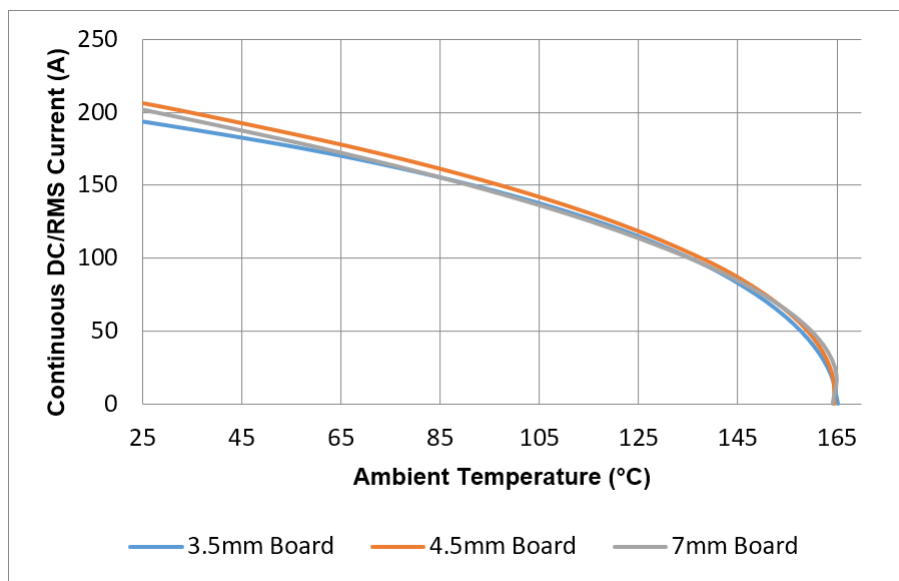
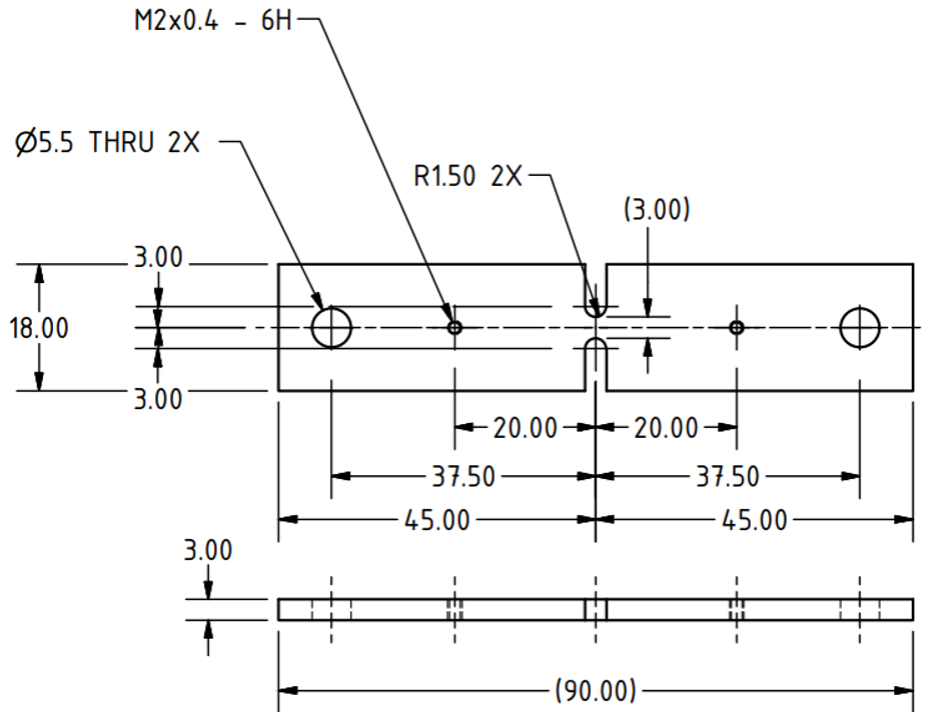

Figure 8: Ambient Temperature vs. Continuous Current

## Busbar and Spacer Characteristics

The reference busbar material is copper 110; the dimensions of the busbar are illustrated below in Figure 9.



**Figure 9: Reference Busbar Dimensions**

The spacers used with the reference busbar design are 3 mm in height and shown Figure 10. The material is Torlon 4203. When choosing a spacer for any application, ensure the material has a low coefficient of thermal expansion (CTE). CTE is a measure of the tendency of a material to change its shape in response to a change in temperature. If a material is significantly expanding and contracting, the air gap could theoretically be altered. See Figure 22 for the relationship between air gap and coupling factor.

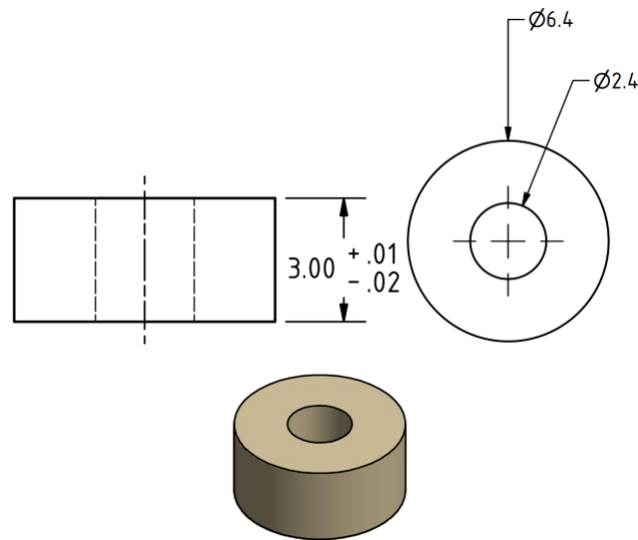

**Figure 10: 3 mm Spacer**

## Schematic

The schematic for the ASEK37612 is documented in Figure 11. The board includes test points for the device pins allowing easy use and troubleshooting of the ACS37612, a scope ground for oscilloscope probe, as well as supporting circuitry including bypass capacitors.

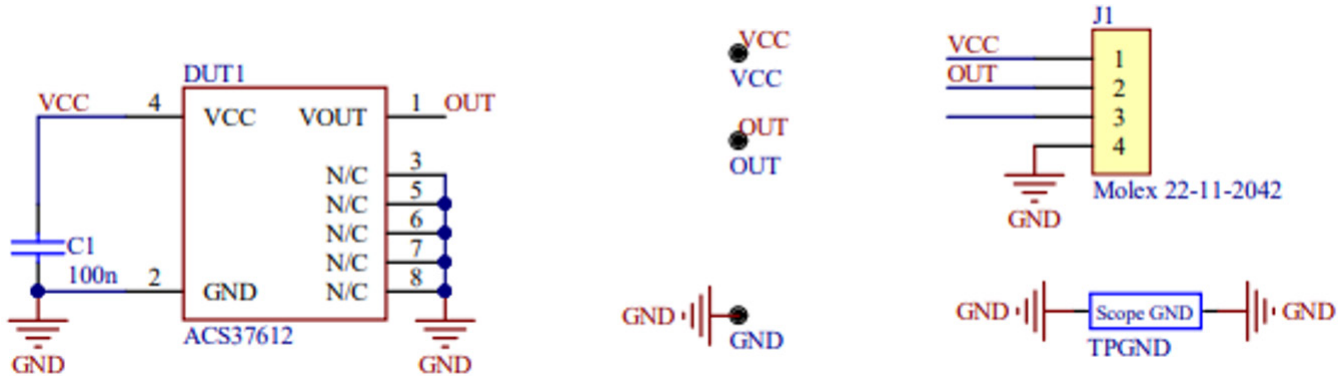

Figure 11: ASEK37612 Evaluation Board Schematic

## APPLICATION INFORMATION

### Functional Description and Theory of Operation

When AC or DC current flows in a PCB copper trace or in a busbar, the ACS37612 will sense the field difference between its two Hall elements, H1 and H2. B<sup>-</sup> and B<sup>+</sup> in Figure 12 below represent the field sensed by the Hall elements. The device output will be proportional to the differential field sensed, which is proportional to the applied current. The relationship between the applied current and the generated field is given by the coupling factor from the following equation, where B<sub>diff</sub> is the differential field, CF is the differential coupling factor, and I is the current applied to the busbar or PCB trace:

$$B_{diff} = CF \times I$$

Equation 1: Relationship between applied current and field sensed by Hall elements

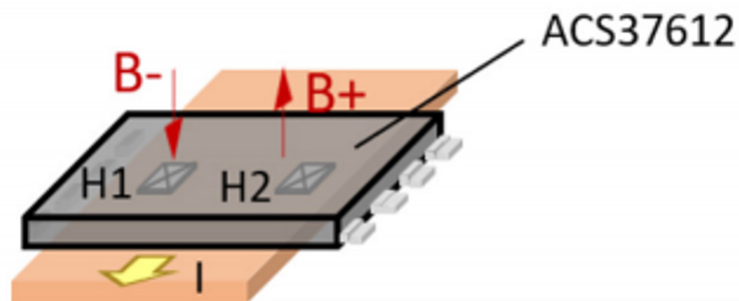

Figure 12: ASEK37612 Busbar and ACS37612 Hall Elements with Sensed Fields

The ASEK37612 reference busbar and ACS37612 Hall elements were simulated (see Figure 13 below). The Hall elements are emphasized in red; magnetic field vectors sensed by the Hall elements were plotted.

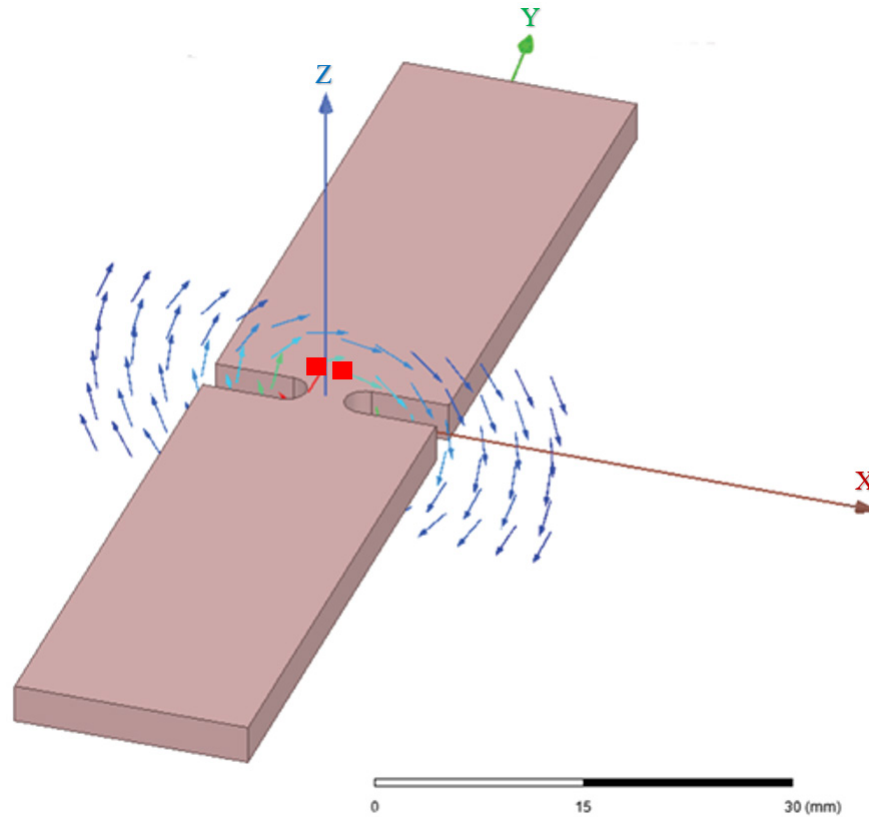

Figure 13: ASEK37612 Reference Busbar and ACS37612 Hall Elements with Magnetic Field Vectors

### Assembly – PCB

The sensor may be installed on the PCB above the busbar, or hung from the PCB, closer to the busbar. The latter increases the magnetic signal and reduces the air gap between the Hall elements and the busbar. See Figure 14 below showing the two different application assemblies.

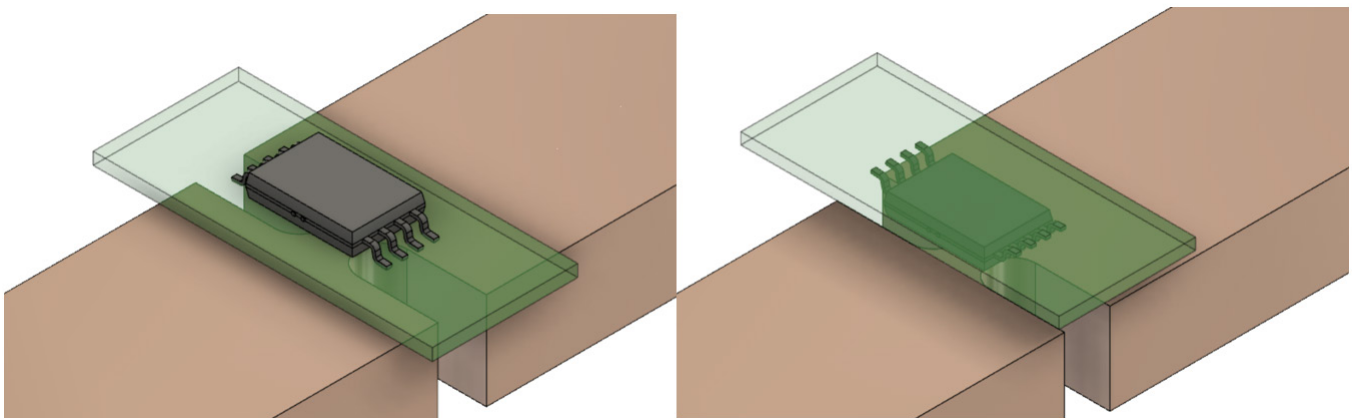

Figure 14: Application Assemblies (normal on the left, inverted on the right)

## Assembly – Reference Busbar

The reference busbar can be affixed to the top of the ASEK37612 PCB by lining up the notch with the TSSOP-8 footprint and using the busbar standoffs (item 2 in Figure 4) and the busbar mounting screws (item 6 in Figure 4). Using the 3 mm busbar standoffs and an active area depth of 0.36 mm, the approximate air gap is 2.26 mm. Note active area depth is the distance from the top of the package to the Hall plate, as defined in the ACS37612 datasheet. Note the PCB laminate has a width of 1.57 mm  $\pm$ 10%.

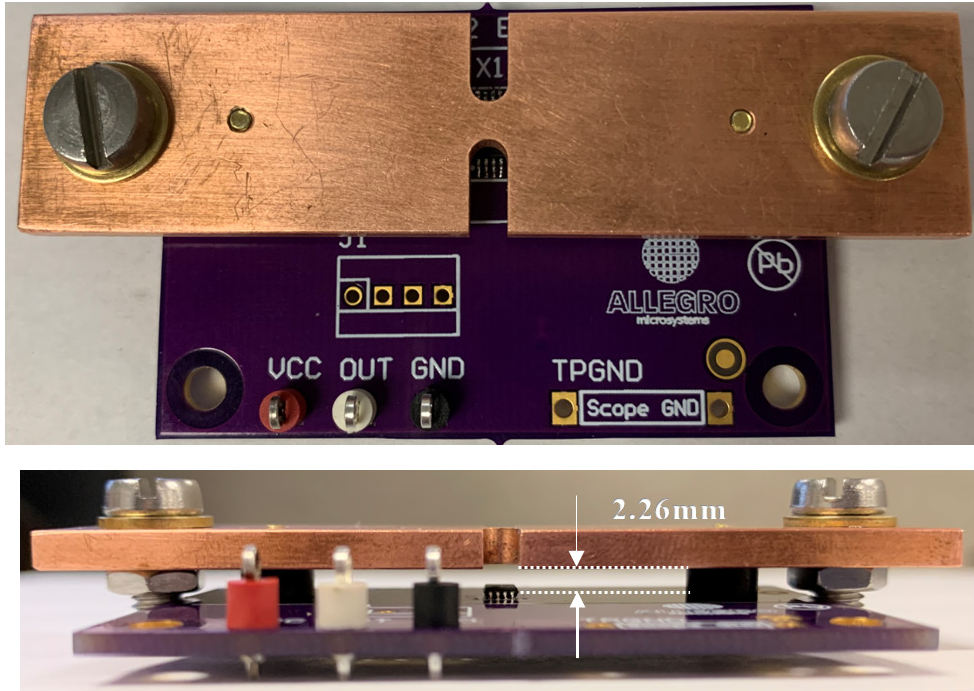

Figure 15: Reference Busbar – Standoffs

## Typical Application – Busbar Sensing

The ACS37612 is optimized for busbar current sensing applications. In the reference design in Figure 16 below, the busbar has a notch at the location where the device is placed. This notch helps to increase coupling factor and improve frequency response. Note that different busbar and notch dimensions can be used to optimize performance and can vary due to application constraints.

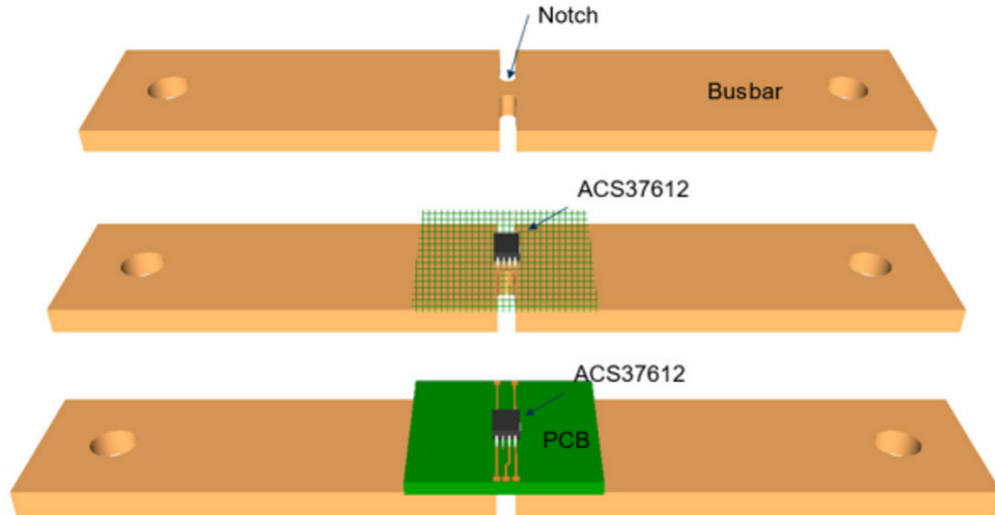

Figure 16: Busbar Current Sensing Reference Design

## Thermal Consequence of a Notched Busbar

A busbar featuring a notch has almost identical thermal performance to a solid busbar. A 2 mm × 2 mm notch adds a resistance of 0.5  $\mu\Omega$  and 50 mW of additional power at 300 A. The thermal comparison of a notched and solid busbar in Figure 17 below illustrates no hotspot at the notch indicating the additional power and resistance is negligible.

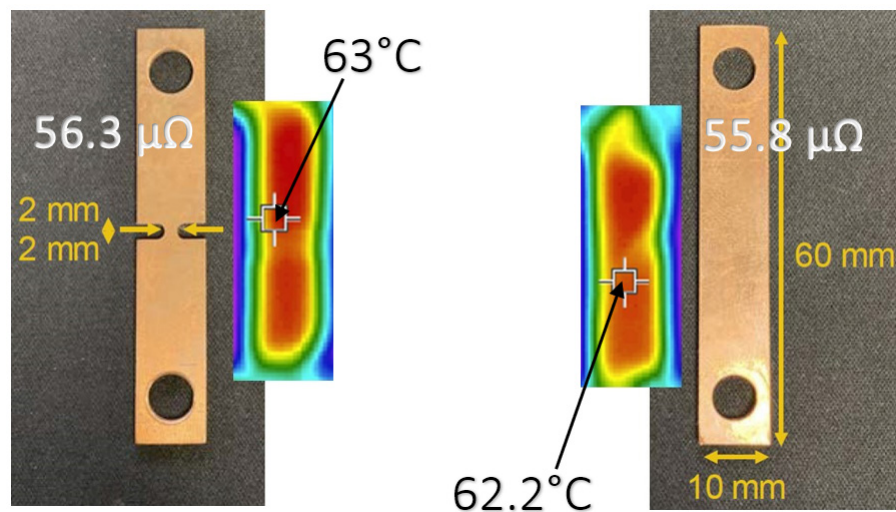

Figure 17: Thermal Comparison of Notched and Solid Busbar

## COMMON MEASUREMENTS

### Evaluation Board Connections

The supply voltage “VCC” [1] may be applied across the “VCC” and “GND” test points. The sensor’s analog output “VOUT” [2] may be observed by attaching an oscilloscope probe or DMM to the test point. These connections are shown on the ASEK37612 evaluation board for reference in Figure 18 below.

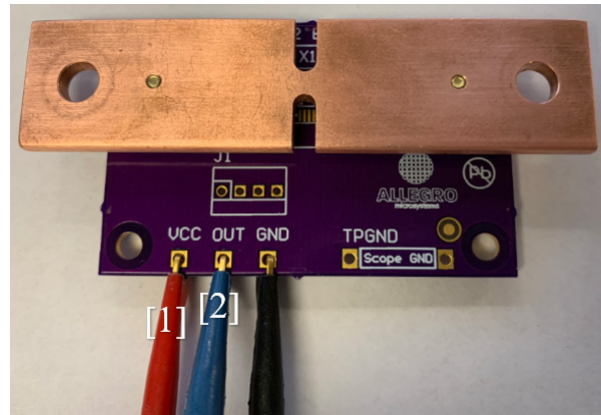

Figure 18: Sensor Connections

High current may be applied directly to the busbar using the current connection screws (item 3 in Figure 4). The high current connections are shown on the ASEK37612 evaluation board for reference below in Figure 19.

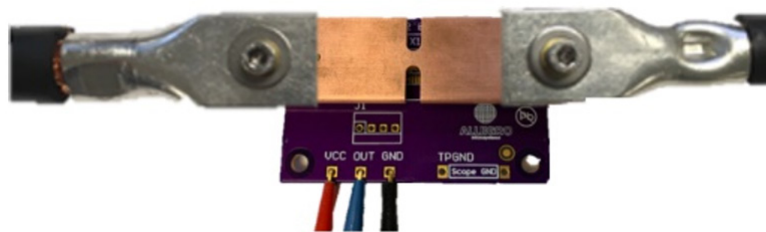

Figure 19: Primary Current Connections

### Evaluation Board Connections

The ASEK37612 evaluation board is useful when measuring device characteristics such as quiescent output voltage,  $V_{OUT(Q)}$ , and sensitivity.

To measure the ACS37612 quiescent output voltage, ensure the device is powered using the correct supply voltage, typically 3.3 V or 5 V. Using an oscilloscope, to view the output waveform, or a multimeter, to view the output voltage level, verify the VOUT pin on the evaluation board is  $V_{CC}/2$  (for bidirectional devices) and  $V_{CC}/10$  (for unidirectional devices). For example, in the case of a bidirectional output device,  $V_{CC} = 5$  V translates into  $V_{OUT(Q)} = 2.5$  V.

To measure sensitivity (sens), first ensure the evaluation board is powered using the VCC and GND test points. After confirming the device is powered, measure the device’s quiescent output voltage. Apply a known current ( $I_P$ ) to the device and measure the device output. Use the following equation below to calculate device sensitivity:

$$\text{sens} \left[ \frac{\text{mV}}{\text{A}} \right] = \frac{V_{\text{OUT}} [\text{V}] - V_{\text{OUT(Q)}} [\text{V}]}{I_P [\text{A}]} \times 1000$$

Equation 2: Sensitivity Calculation for ACS37612

## BUSBAR DIMENSIONS

The ASEK37612 evaluation kit includes a reference busbar which is suitable for measuring primary currents up to 1000 A with the ACS37612. The busbar dimensions are 90 mm × 18 mm × 3mm (length × width × height). Figure 20 below includes dimension definitions of the reference busbar (not to scale). The Hall spacing, as defined in the ACS37612 datasheet, is 1.87 mm. The notch length and notch width in the reference busbar included in the ASEK37612 evaluation kit are both 3 mm. The dimensions of the notch can vary based on application criteria. See Table 5 below for a summary of the reference busbar dimensions. The full-scale current range for a particular busbar is determined by the dimensions of the notch and the closed loop system on the ACS37612 sensor.

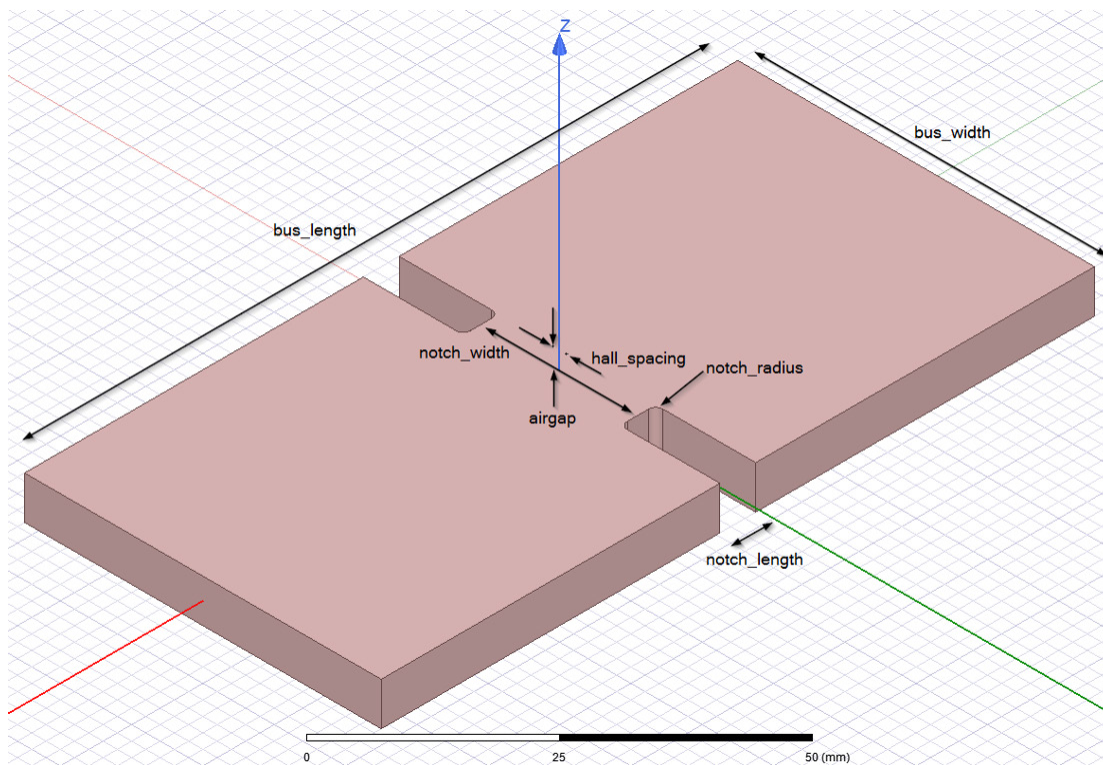

Figure 20: Reference Busbar Dimension Definitions

Table 5: Reference Busbar Dimensions Summary

Dimension	Value (mm)
Bus length	90
Bus width	18
Bus height/thickness	3
Notch length	3
Notch width	3
Notch radius	1.5
Hall spacing	1.87

## Busbar Design Recommendations

For busbar design recommendations, refer to “Guidelines for Designing a Busbar with Notch for Allegro’s Coreless AS37612 Differential Current Sensor” (<https://www.allegromicro.com/-/media/allegro/allegromicro/files/application-notes/an296188-acs37612-guidelines-for-designing-a-busbar-web.ashx>) along with Allegro’s interactive busbar design tool in the ACS37612 Samples Programmer on ACS37612 webpage (<https://allegromicro.com/en/products/sense/current-sensor-ics/sip-package-zero-to-thousand-amp-sensor-ics/acs37612>). See Figure 21 below for an illustration of the busbar design GUI.

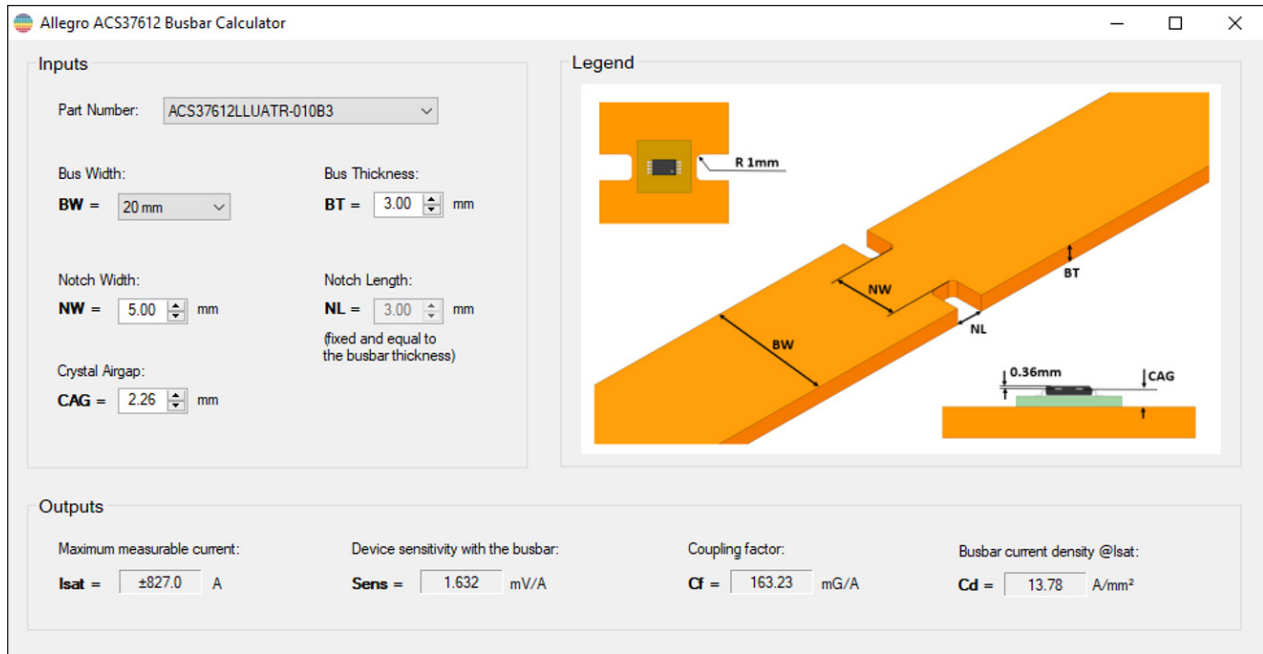

Figure 21: ACS37612 Busbar Calculator GUI

Inputs to the GUI include part number, bus width, bus thickness, notch width, and air gap.

For PCB sensing design recommendations, refer to the Coreless PCB Calculator, located under “Design Support Tools” on the ACS37612 webpage (<https://allegromicro.com/en/products/sense/current-sensor-ics/sip-package-zero-to-thousand-amp-sensor-ics/acs37612>). See Figure 22 below for reference.

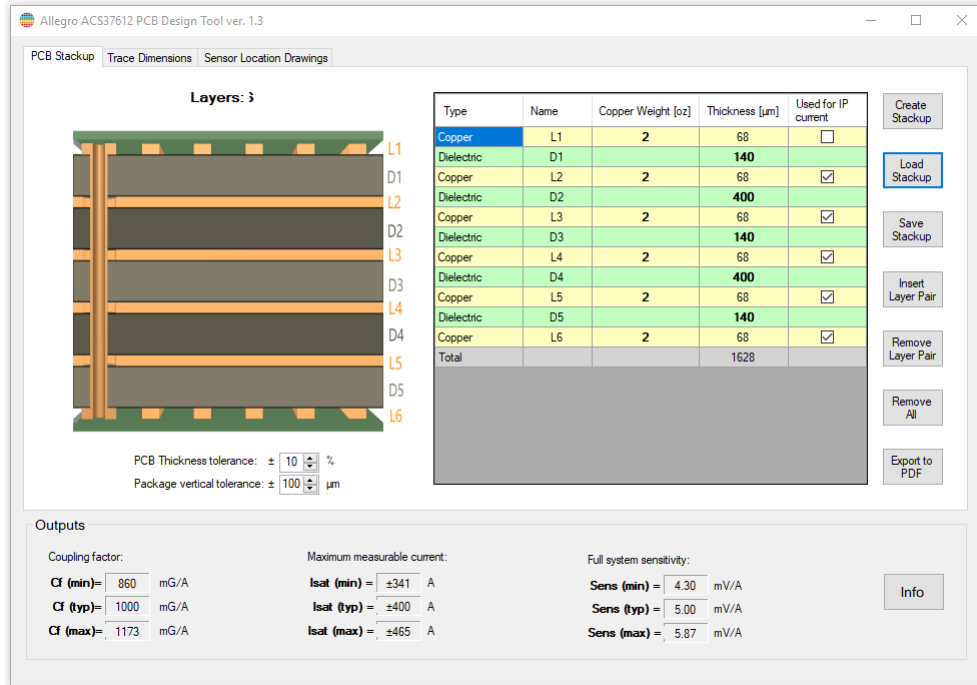

Figure 22: Relationship between Air Gap and Coupling Factor

### Relationship Between Coupling Factor and Air Gap

Using the reference busbar included with the ASEK37612, the plot below illustrates the relationship between coupling factor and the air gap between the busbar and the package. The expected coupling factor (CF) using the ASEK37612 evaluation board and busbar atop the standoffs is about 0.21 G/A.

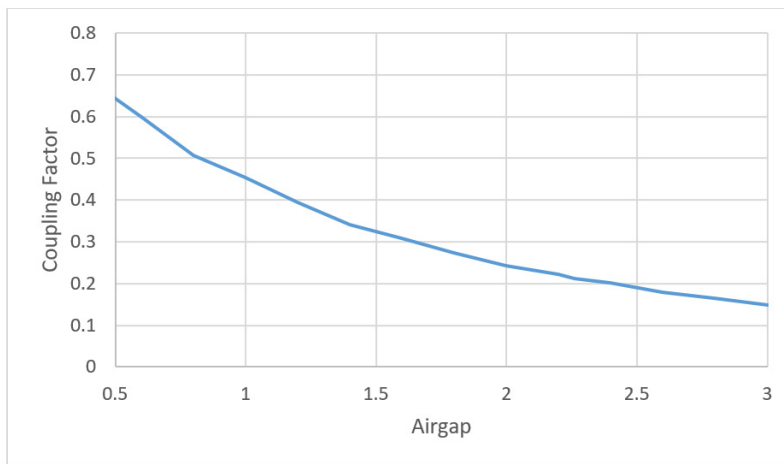

Figure 23: Relationship between Air Gap and Coupling Factor

## CALCULATING FULL-SCALE CURRENT RANGE USING CF AND IC SENSITIVITY

The ACS37612 is currently offered in two different gain selects: 10 mV/G and 15 mV/G. The full-scale current sensing range of the device depends on the sensitivity of the sensor and the design of the reference busbar. To calculate the maximum current sensing range, coupling factor and IC sensitivity must be known. The example below demonstrates how to calculate the maximum current sensing using a coupling factor of 0.21 G/A and a device sensitivity of 10 mV/G. The desired output voltage swing is 2000 mV.

$$2000 \text{ mV} \times \frac{\text{G}}{10 \text{ mV}} \times \frac{\text{A}}{0.21 \text{ G}} = 952 \text{ A}$$

**Equation 3**

For the above example, the maximum current sensing range would be 952 A.

## PCB SENSING – TYPICAL APPLICATION

The ACS37612 can be used in PCB current sensing applications, where current flows under the sensor is one or multiple copper layers. In the reference design in Figure 23 below, the copper trace width is reduced below the device (neckdown) to increase coupling factor. Allegro offers ASEK37612 evaluation boards with varying copper trace widths. Multiple PCB layers can be used to carry current depending on the design used, and different dimensions and arrangement of the copper layers can be used to optimize performance depending on application constraints. The application information and measurement techniques above are relevant to the ASEK37612 PCB sensing application.

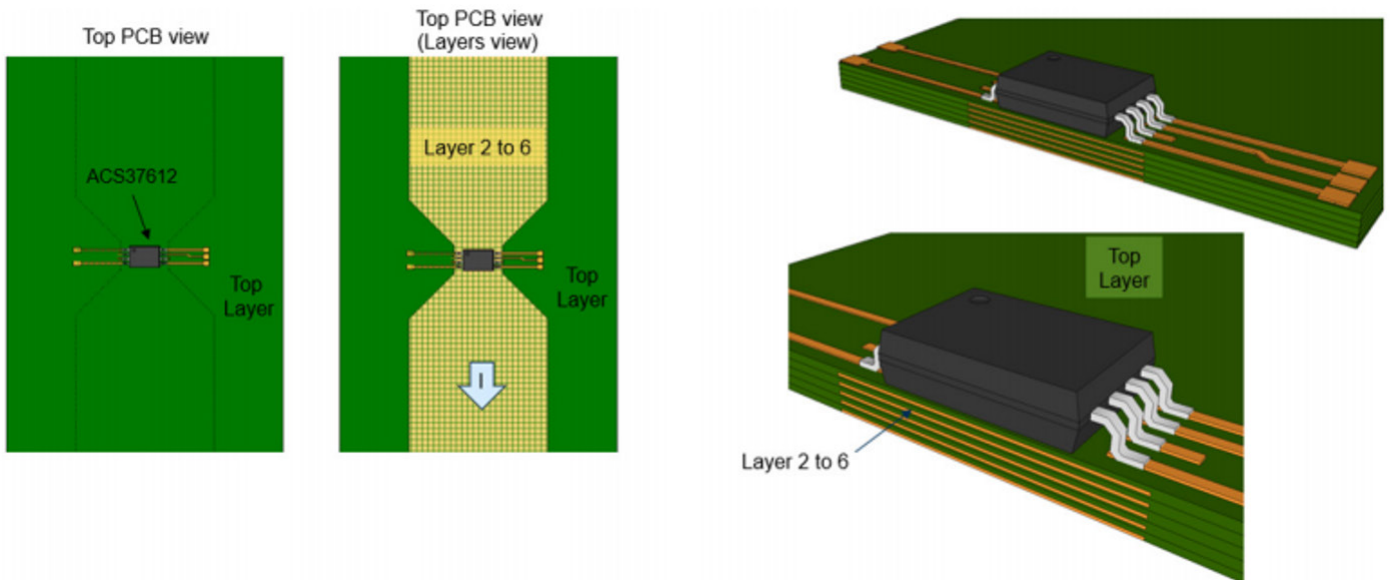

**Figure 24: PCB Current Sensing Application**

## Components

The ASEK37612 evaluation board consists of two layers; top and bottom layers can be seen below. The ASEK37612 PCB includes:

1. Footprint for 8-Pin TSSOP
2. Banana jacks (J1 and J2) for applied current
3. Header for wiring harness
4. Test points for fast connections
5. Test points ground for scope clips

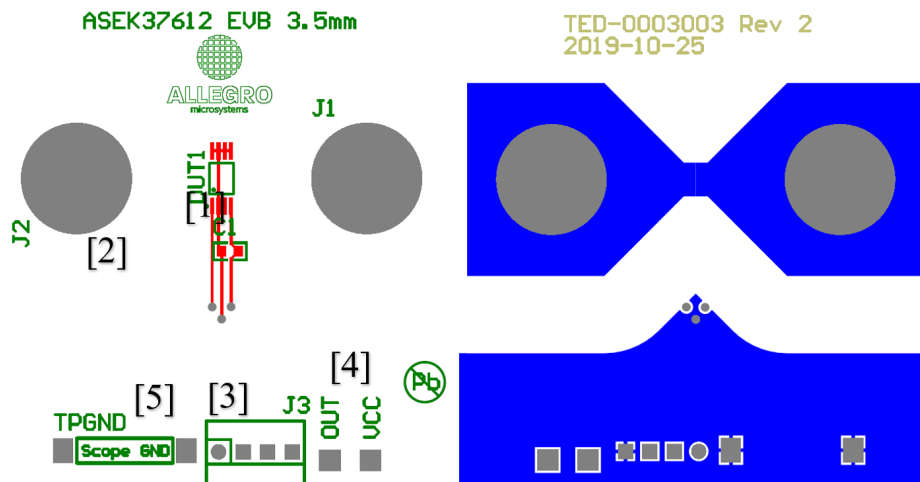

Figure 25: ASEK37612 EVB 3.5 mm PCB Top (left) and Bottom Layers (right)



Figure 26: PCB Top (left) and Bottom Layers (right), 3.5 mm copper width below sensor

## Schematic

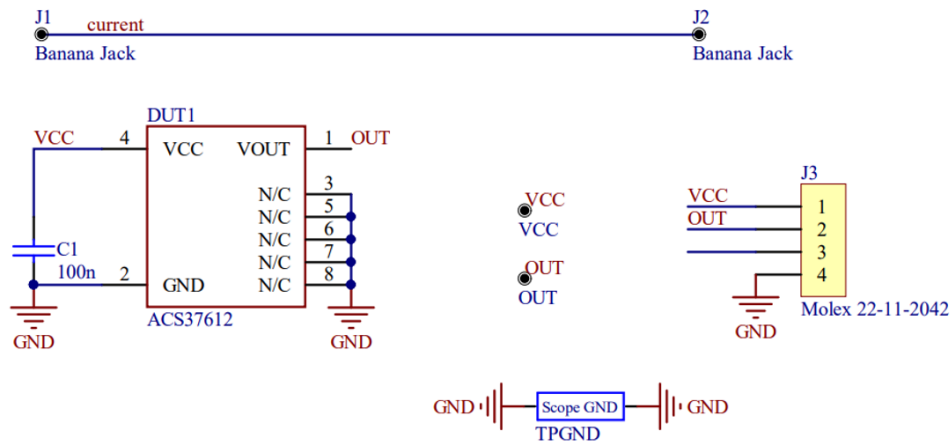

Figure 27: ASEK37612 EVB Schematic, 3.5 mm

## BILL OF MATERIALS

The bill of materials (BOM) for the ASEK37612 can be viewed in the table below.

Table 6: ASEK37612 Bill of Materials

Item	Qty	Manufacturer	Part Number	Description	Designator
1	1	Allegro	37612	IC, TSSOP-8, sensor	DUT1
2	1	Allegro	85-0929	LE Straddler Busbar Demo	X1
3	1	AVX	12065C104KAT2A	Capacitor, 1206, mono, X7R, 50 V, 100 nF	C1
4	1	Molex	22-11-2042	Connector, thro, header, Molex 100 mil, 4 circuit, gold	J1
5	3	Keystone	5005	Test point, thro, compact, 62 mil PCB, red	GND, OUT, VCC
6	1			Jumper, thro, used as scope GND, bend from 18 g wire, install 0.25 inch above PCB	TPGND
7	1			PCB, TED-0002978 Rev 3 Gerber files	PCB
8	1	Allegro	85-0929-001	Current busbar	N/A
9	2	Allegro	85-0929-002	3 mm KT spacer	N/A
10	2	McMaster	91800A322	SCHMS, M5X0.8X12, 18-8	N/A
11	2	McMaster	91635A230	FW, M5, Brass	N/A
12	2	McMaster	91828A241	HN, M5 × 0.8, 18-8	N/A
13	2	McMaster	96741A015	PHPMS, M2X0.4X8, Brass	N/A
14	4	McMaster	96741A116	PHPMS, M3X0.5X6, Brass	N/A
15	4	McMaster	94868A168	M3 Standoff 12 mm Long	N/A

---

## Revision History

Number	Date	Description
–	November 17, 2020	Initial Release
1	January 6, 2022	Minor editorial updates
2	January 13, 2023	Minor editorial updates

Copyright 2023, Allegro MicroSystems.

The information contained in this document does not constitute any representation, warranty, assurance, guaranty, or inducement by Allegro to the customer with respect to the subject matter of this document. The information being provided does not guarantee that a process based on this information will be reliable, or that Allegro has explored all of the possible failure modes. It is the customer's responsibility to do sufficient qualification testing of the final product to ensure that it is reliable and meets all design requirements.

Copies of this document are considered uncontrolled documents.

For the latest version of this document, visit our website:

[www.allegromicro.com](http://www.allegromicro.com)

## Looking for pricing, stock, or lifecycle information?

Click below to explore more details on WIN SOURCE:

- ⊖ [View ASEK37612-BUSBAR-DK on WIN SOURCE](#)
- ⊖ [Allegro MicroSystems, LLC Information](#)

## Optimize Your Supply Chain with WIN SOURCE Solutions

- ✓ Global Sourcing Solution
- ✓ Obsolete Management
- ✓ Cost Control Management
- ✓ Shortage Management
- ✓ Alternative Solution
- ✓ Excess Inventory Management