



**THE DATASHEET OF
MML20242HT1**



Enhancement Mode pHEMT Technology (E-pHEMT)

Low Noise Amplifier

The MML20242H is a 2-stage low noise amplifier (LNA) with active bias and high isolation for use in cellular infrastructure applications. It is designed for a range of low noise, high linearity applications such as picocell, femtocell, tower mounted amplifiers (TMA) and receiver front-end circuits. It operates from a single voltage supply and is suitable for applications with frequencies from 1400 to 2800 MHz such as TD-SCDMA, W-CDMA, UMTS, PCS, LTE and BWA.

Features

- Low Noise Figure: 0.59 dB @ 1950 MHz
- Frequency: 1400–2800 MHz
- Unconditionally Stable over Temperature
- High Reverse Isolation: -51 dB @ 1950 MHz
- P1dB: 24 dBm @ 1950 MHz
- Small-Signal Gain: 34 dB @ 1950 MHz
- Third Order Output Intercept Point: 39.5 dBm @ 1950 MHz
- Active Bias Control (adjustable externally)
- Single 5 V Supply
- Supply Current: 160 mA
- 50 Ohm Operation (some external matching required)
- Cost-effective 12-pin, 3 mm QFN Surface Mount Plastic Package
- In Tape and Reel. T1 Suffix = 1,000 Units, 12 mm Tape Width, 7-inch Reel.

MML20242HT1

**1400–2800 MHz, 34 dB
24 dBm, 0.59 dB NF
E-pHEMT LNA**



QFN 3 x 3

Table 1. Typical Performance (1)

Characteristic	Symbol	1400 MHz	1950 MHz	2800 MHz	Unit
Noise Figure (2)	NF	0.55	0.59	0.97	dB
Input Return Loss (S11)	IRL	-15	-18	-18	dB
Output Return Loss (S22)	ORL	-14	-15	-15	dB
Small-Signal Gain (S21)	G _p	38	34	31.5	dB
Power Output @ 1dB Compression	P1dB	23.5	24	24	dBm
Third Order Input Intercept Point	IIP3	1	5.5	8	dBm
Third Order Output Intercept Point	OIP3	39	39.5	39.5	dBm

1. V_{DD} = 5 Vdc, T_A = 25°C, 50 ohm system, application circuit tuned for specified frequency.

2. Noise figure value calculated with connector losses removed.

Table 2. Maximum Ratings

Rating	Symbol	Value	Unit
Supply Voltage	V _{DD}	6	V
Supply Current	I _{DD}	300	mA
RF Input Power (3)	P _{in}	28	dBm
Storage Temperature Range	T _{stg}	-65 to +150	°C
Junction Temperature	T _J	175	°C

3. Measured using CW test signal.

Table 3. Thermal Characteristics

Characteristic	Symbol	Value (4)	Unit
Thermal Resistance, Junction to Case Case Temperature 95°C, 5 Vdc, 163 mA, no RF applied	R _{θJC}	40	°C/W

4. Refer to AN1955, *Thermal Measurement Methodology of RF Power Amplifiers*. Go to <http://www.freescale.com/rf>. Select Documentation/Application Notes - AN1955.

Table 4. Electrical Characteristics ($V_{DD} = 5 \text{ Vdc}$, 2140 MHz, $T_A = 25^\circ\text{C}$, 50 ohm system, in Freescale Application Circuit)

Characteristic	Symbol	Min	Typ	Max	Unit
Small-Signal Gain (S21)	G_p	30.6	32.5	—	dB
Input Return Loss (S11)	IRL	—	-18	—	dB
Output Return Loss (S22)	ORL	—	-15	—	dB
Power Output @ 1dB Compression	P1dB	—	24	—	dBm
Third Order Input Intercept Point	IIP3	—	7	—	dBm
Third Order Output Intercept Point	OIP3	—	39.5	—	dBm
Reverse Isolation (S12)	S12	—	-50	—	dBm
Noise Figure ⁽¹⁾	NF	—	0.7	—	dB
Supply Current ⁽²⁾	I_{DD}	117	160	207	mA
Supply Voltage	V_{DD}	—	5	—	V

Table 5. ESD Protection Characteristics

Test Methodology	Class
Human Body Model (per JESD22-A114)	0
Machine Model (per EIA/JESD22-A115)	A
Charge Device Model (per JESD22-C101)	IV

Table 6. Moisture Sensitivity Level

Test Methodology	Rating	Package Peak Temperature	Unit
Per JESD22-A113, IPC/JEDEC J-STD-020	1	260	$^\circ\text{C}$

1. Noise figure value calculated with connector losses removed.
2. DC current measured with no RF signal applied.

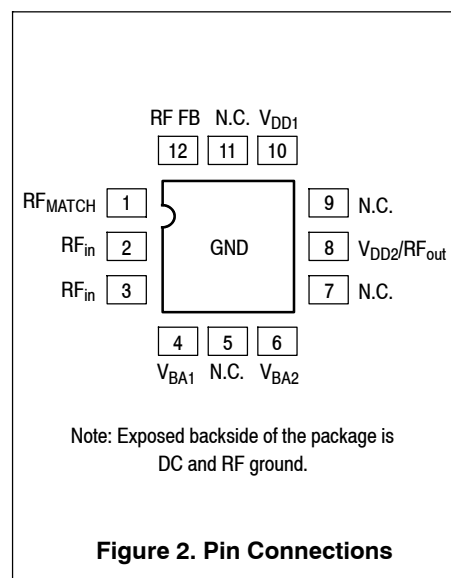
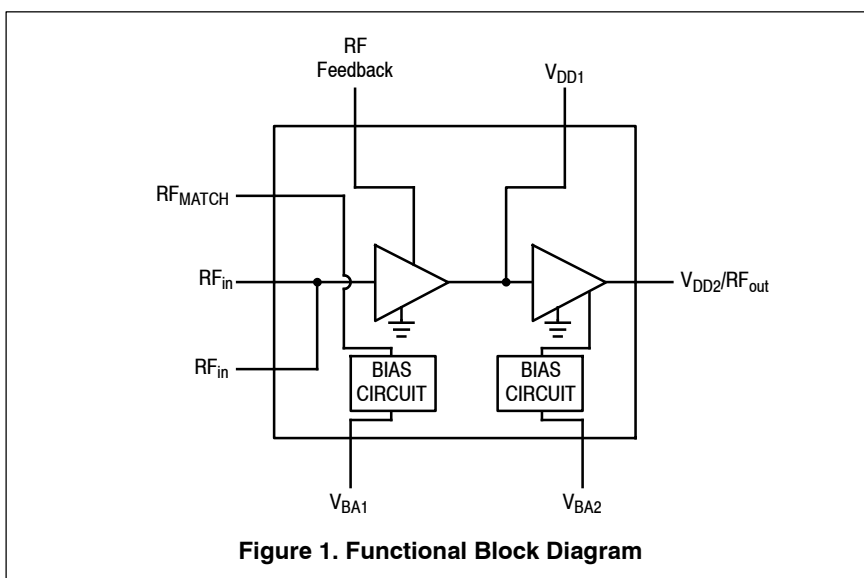

50 OHM APPLICATION CIRCUIT: 1950 MHz

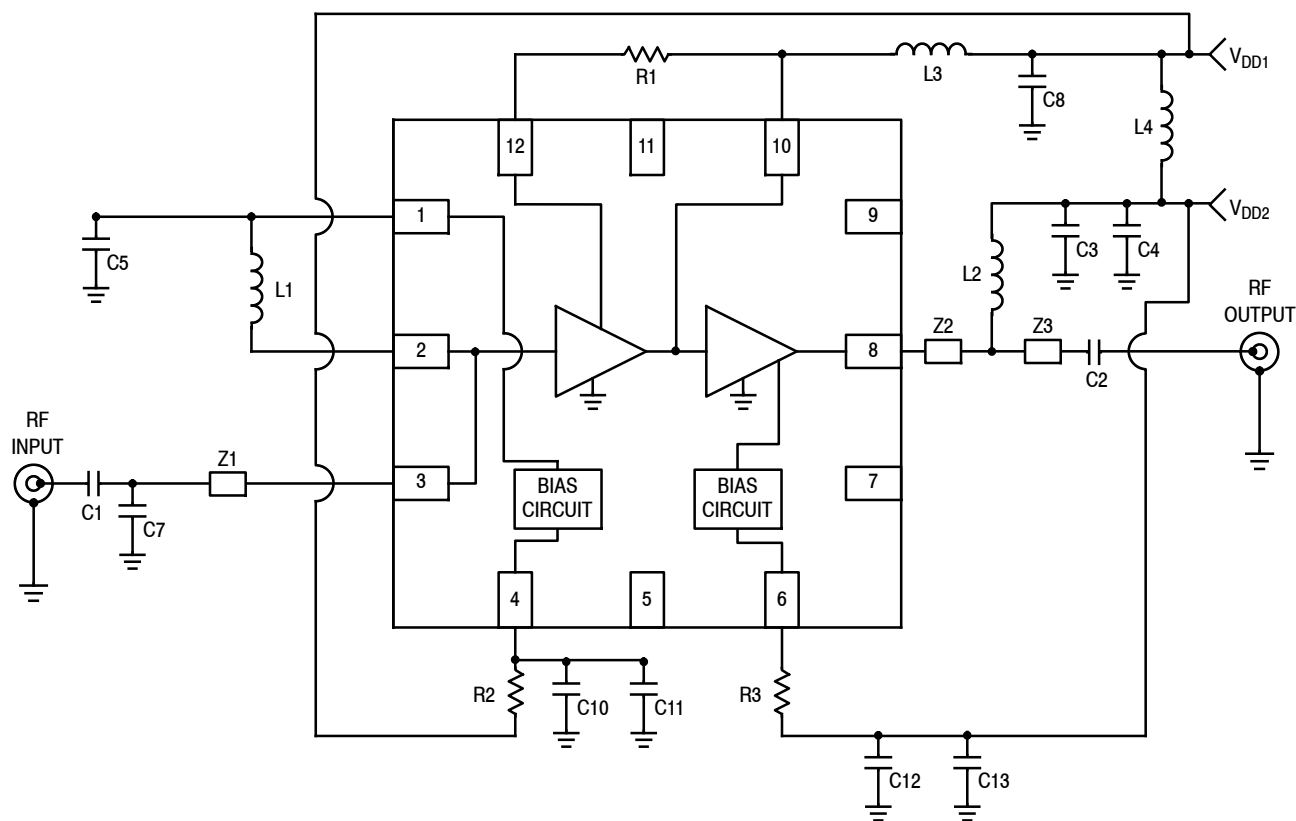

- Z1 0.248" × 0.021" Microstrip
- Z2 0.050" × 0.021" Microstrip
- Z3 0.030" × 0.021" Microstrip

Figure 3. MML20242HT1 Test Circuit Schematic

Table 7. MML20242HT1 Test Circuit Component Designations and Values

Part	Description	Part Number	Manufacturer
C1, C5	18 pF Chip Capacitors	GJM1555C1H180GB01	Murata
C2, C3, C8, C11, C12	18 pF Chip Capacitors	GRM1555C1H180JA01	Murata
C4, C10, C13	0.1 μF Chip Capacitors	GRM155R61A104K01	Murata
C6, C9	Components Not Placed		
C7	0.6 pF Chip Capacitor	GJM1555C1HR60WB01	Murata
L1	3.3 nH Chip Inductor	0402HP-3N3XJLW	Coilcraft
L2, L4	10 nH Chip Inductors	0402CS-10NXJLW	Coilcraft
L3	2.2 nH Chip Inductor	0402CS-2N2XJLW	Coilcraft
R1	180 Ω Chip Resistor	RC0402FR-07-180RL	Yageo
R2, R3	1200 Ω Chip Resistors	RC0402FR-07-1K2RL	Yageo
PCB	0.010", ε _r = 3.48, Multilayer	RO4350B	Rogers

Note: Component numbers C6 and C9 are labeled on board but not placed.

50 OHM APPLICATION CIRCUIT: 1950 MHz

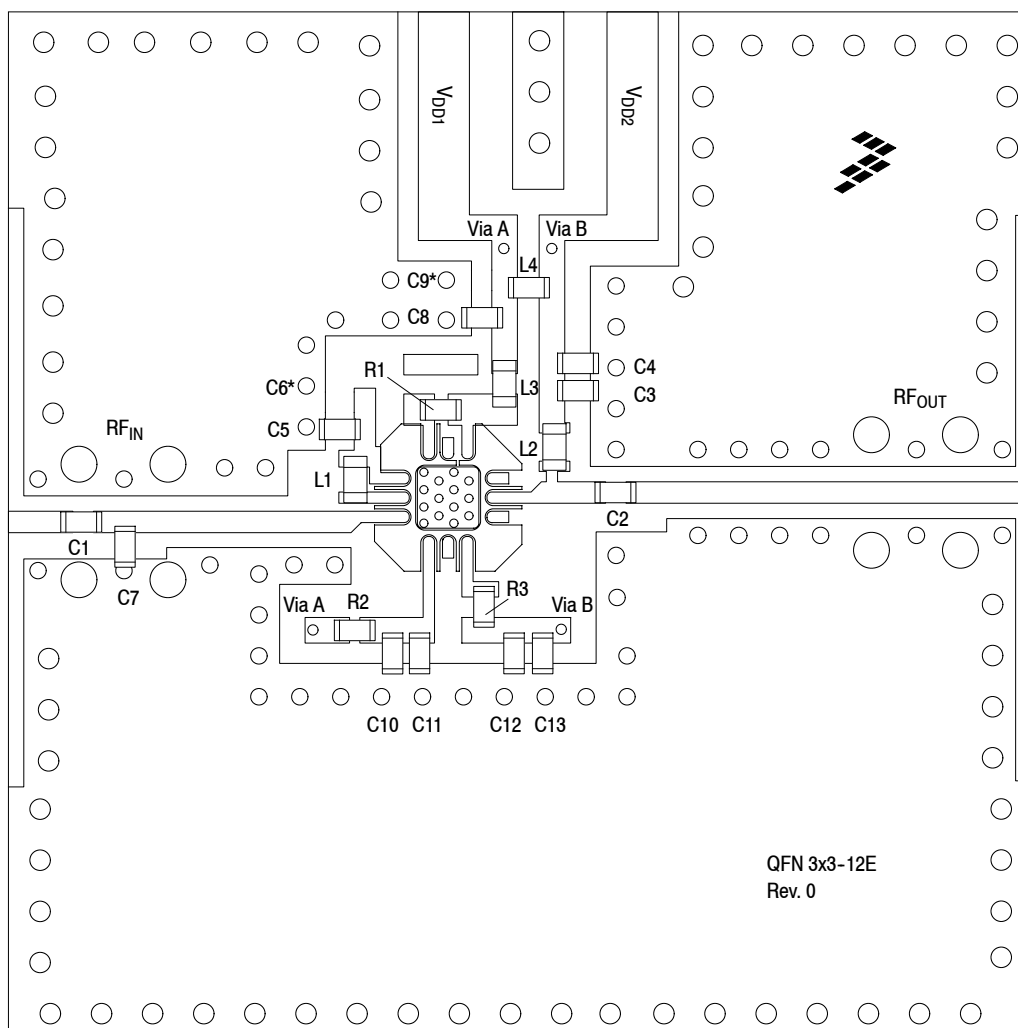

Note: Component numbers C6* and C9* are labeled on board but not placed.

Figure 4. MML20242HT1 Test Circuit Component Layout

Table 7. MML20242HT1 Test Circuit Component Designations and Values

Part	Description	Part Number	Manufacturer
C1, C5	18 pF Chip Capacitors	GJM1555C1H180GB01	Murata
C2, C3, C8, C11, C12	18 pF Chip Capacitors	GRM1555C1H180JA01	Murata
C4, C10, C13	0.1 μ F Chip Capacitors	GRM155R61A104K01	Murata
C6, C9	Components Not Placed		
C7	0.6 pF Chip Capacitor	GJM1555C1HR60WB01	Murata
L1	3.3 nH Chip Inductor	0402HP-3N3XJLW	Coilcraft
L2, L4	10 nH Chip Inductors	0402CS-10NXJLW	Coilcraft
L3	2.2 nH Chip Inductor	0402CS-2N2XJLW	Coilcraft
R1	180 Ω Chip Resistor	RC0402FR-07-180RL	Yageo
R2, R3	1200 Ω Chip Resistors	RC0402FR-07-1K2RL	Yageo
PCB	0.010", $\epsilon_r = 3.48$, Multilayer	RO4350B	Rogers

(Test Circuit Component Designations and Values repeated for reference.)

50 OHM TYPICAL CHARACTERISTICS: 1950 MHz

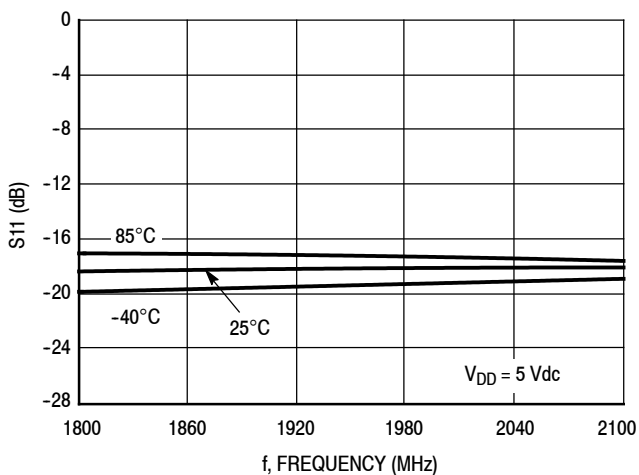

Figure 5. S11 versus Frequency versus Temperature

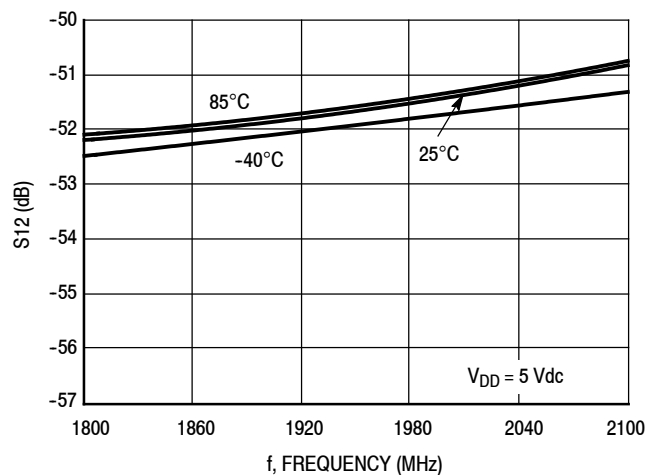

Figure 6. S12 versus Frequency versus Temperature

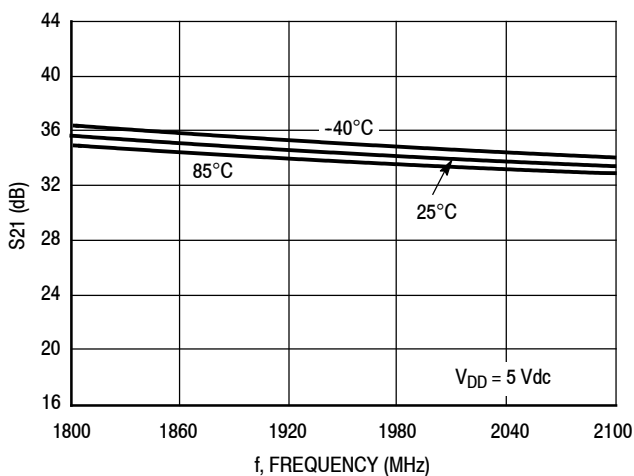

Figure 7. S21 versus Frequency versus Temperature

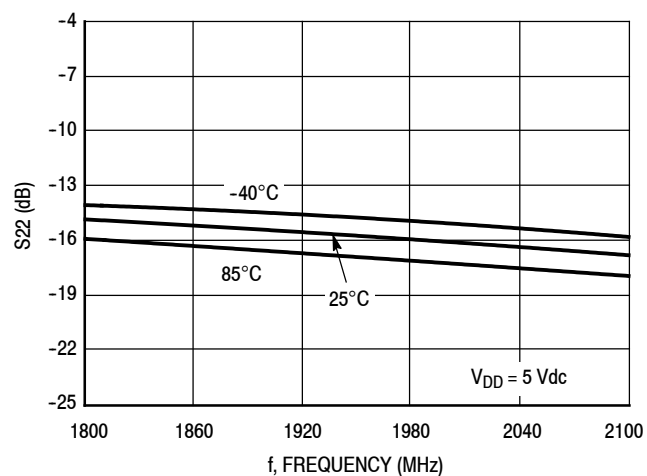

Figure 8. S22 versus Frequency versus Temperature

50 OHM TYPICAL CHARACTERISTICS: 1950 MHz

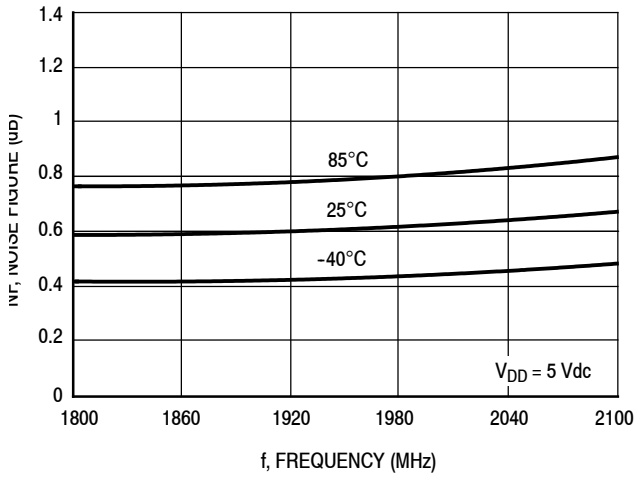

Figure 9. Noise Figure versus Frequency versus Temperature

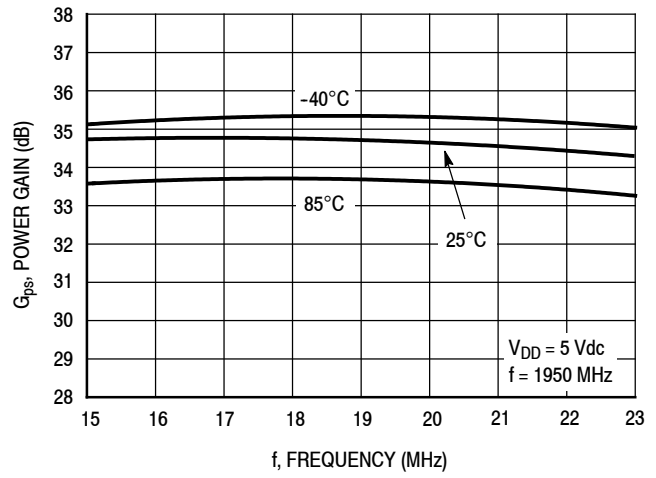

Figure 10. Power Gain versus Output Power versus Temperature, CW

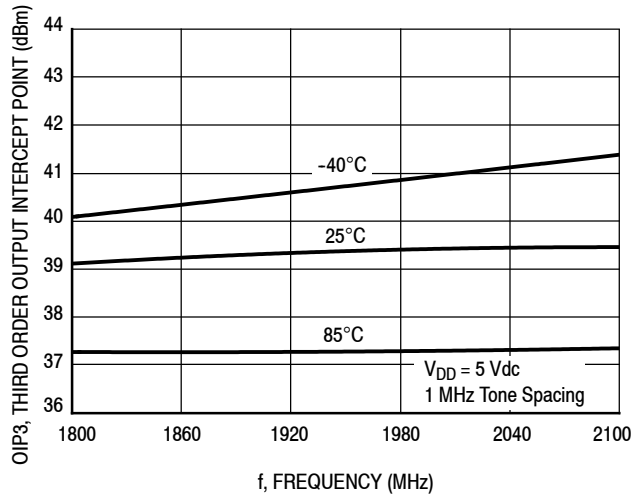

Figure 11. Third Order Output Intercept Point (Two-Tone) versus Frequency versus Temperature

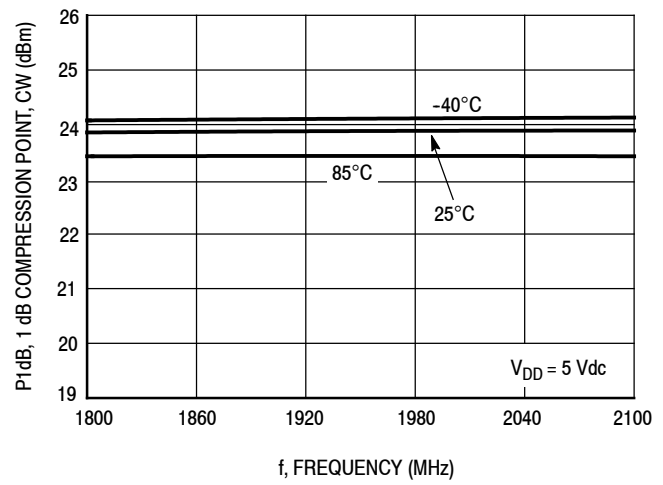
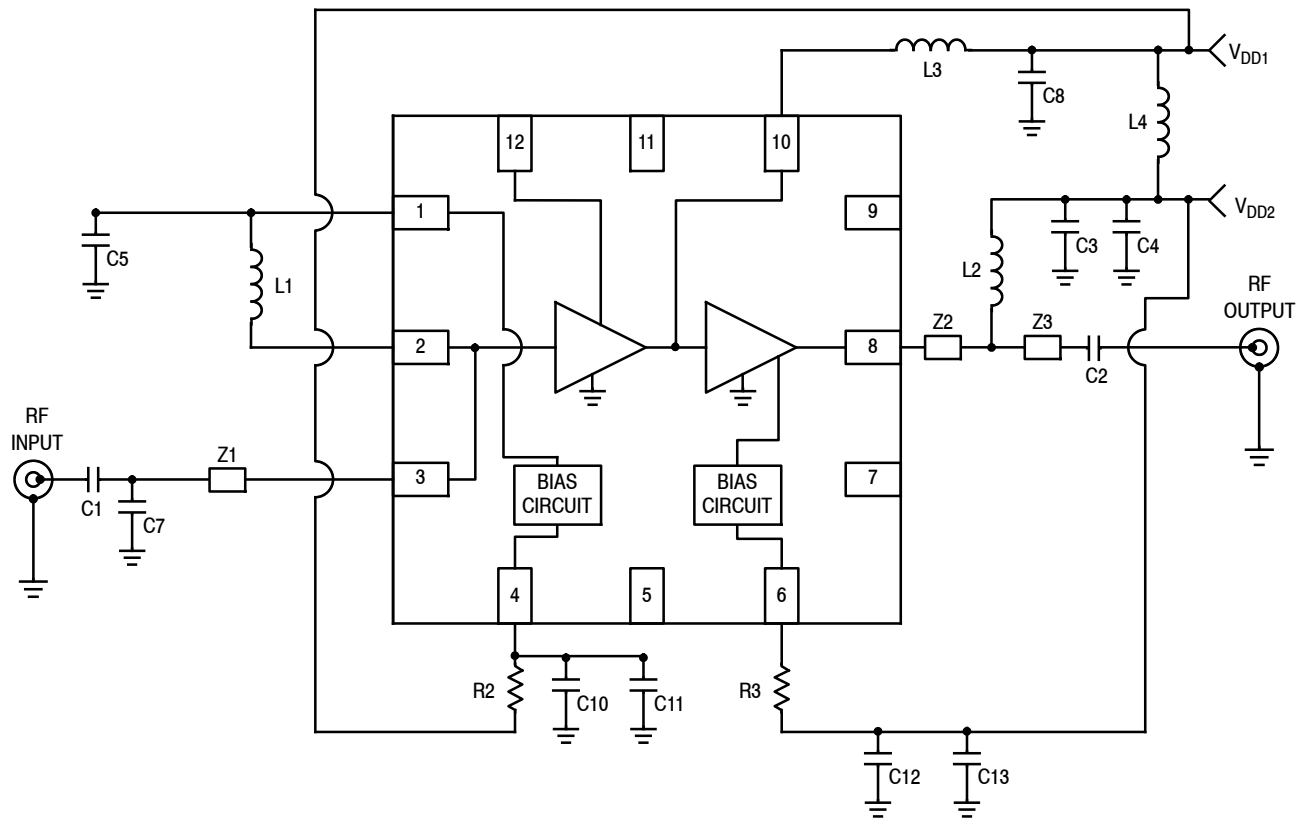

Figure 12. P1dB versus Frequency versus Temperature, CW

50 OHM APPLICATION CIRCUIT: 2535 MHz



- Z1 0.248" × 0.021" Microstrip
- Z2 0.050" × 0.021" Microstrip
- Z3 0.030" × 0.021" Microstrip

Figure 13. MML20242HT1 Test Circuit Schematic

Table 8. MML20242HT1 Test Circuit Component Designations and Values

Part	Description	Part Number	Manufacturer
C1, C5	18 pF Chip Capacitors	GJM1555C1H180GB01	Murata
C2, C3, C8, C11, C12	18 pF Chip Capacitors	GRM1555C1H180JA01	Murata
C4, C10, C13	0.1 μF Chip Capacitors	GRM155R61A104K01	Murata
C6, C9	Components Not Placed		
C7	0.6 pF Chip Capacitor	GJM1555C1HR60WB01	Murata
L1	2.7 nH Chip Inductor	0402HP-2N7XJLW	Coilcraft
L2, L4	6.8 nH Chip Inductors	0402CS-6N8XJLW	Coilcraft
L3	1.0 nH Chip Inductor	0402CS-1N0XJLW	Coilcraft
R1	Component Not Placed		
R2, R3	1200 Ω Chip Resistors	RC0402FR-07-1K2RL	Yageo
PCB	0.010", ε _r = 3.48, Multilayer	RO4350B	Rogers

Note: Component numbers C6, C9 and R1 are labeled on board but not placed.

50 OHM APPLICATION CIRCUIT: 2535 MHz

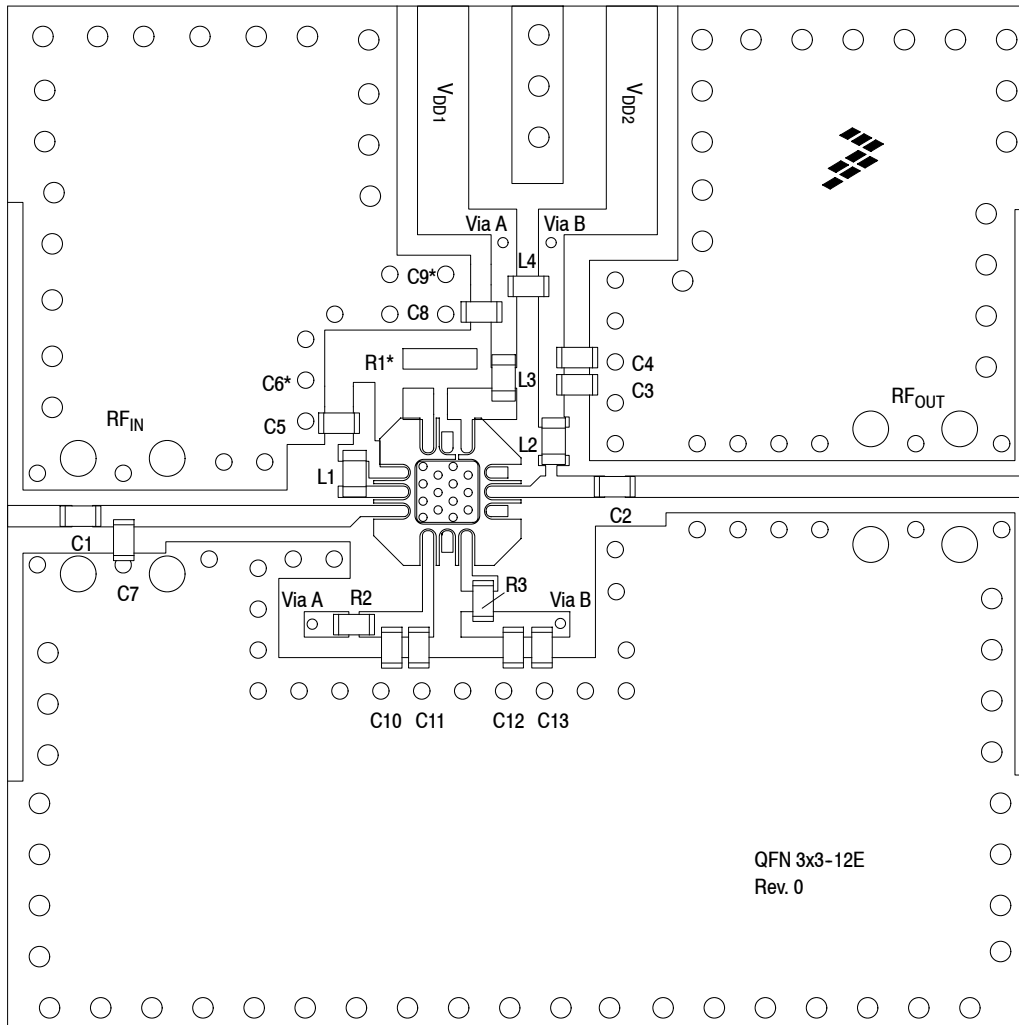

Note: Component numbers C6*, C9* and R1* are labeled on board but not placed.

Figure 14. MML20242HT1 Test Circuit Component Layout

Table 8. MML20242HT1 Test Circuit Component Designations and Values

Part	Description	Part Number	Manufacturer
C1, C5	18 pF Chip Capacitors	GJM1555C1H180GB01	Murata
C2, C3, C8, C11, C12	18 pF Chip Capacitors	GRM1555C1H180JA01	Murata
C4, C10, C13	0.1 μ F Chip Capacitors	GRM155R61A104K01	Murata
C6, C9	Components Not Placed		
C7	0.6 pF Chip Capacitor	GJM1555C1HR60WB01	Murata
L1	2.7 nH Chip Inductor	0402HP-2N7XJLW	Coilcraft
L2, L4	6.8 nH Chip Inductors	0402CS-6N8XJLW	Coilcraft
L3	1.0 nH Chip Inductor	0402CS-1N0XJLW	Coilcraft
R1	Component Not Placed		
R2, R3	1200 Ω Chip Resistors	RC0402FR-07-1K2RL	Yageo
PCB	0.010", $\epsilon_r = 3.48$, Multilayer	RO4350B	Rogers

(Test Circuit Component Designations and Values repeated for reference.)

50 OHM TYPICAL CHARACTERISTICS: 2535 MHz

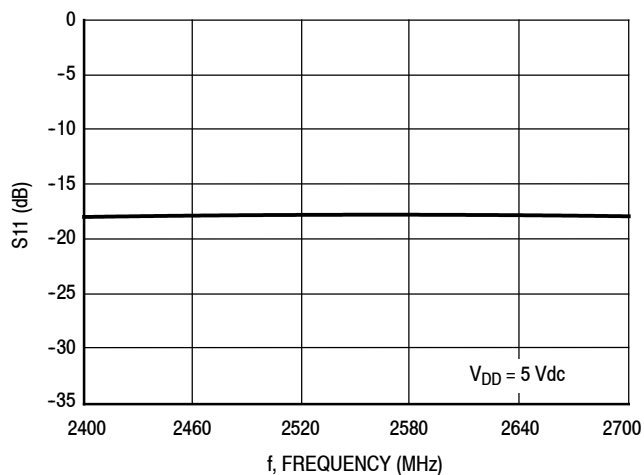

Figure 15. S11 versus Frequency

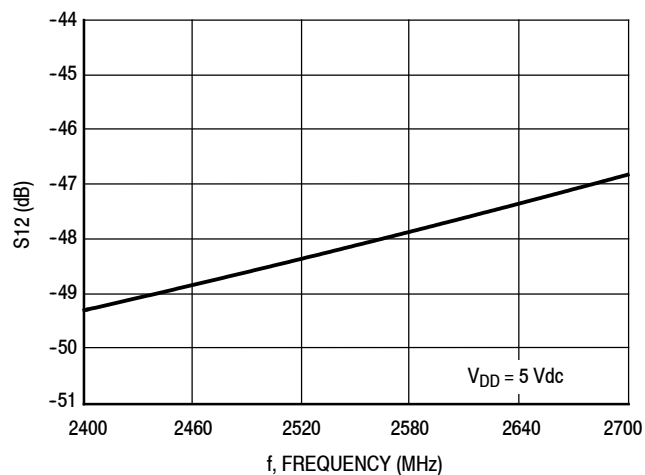

Figure 16. S12 versus Frequency

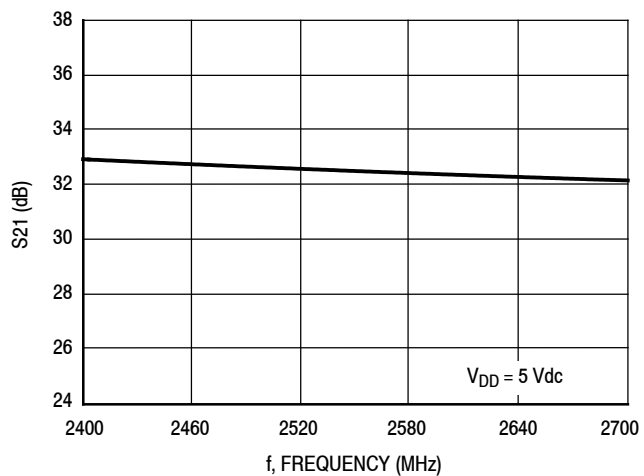

Figure 17. S21 versus Frequency

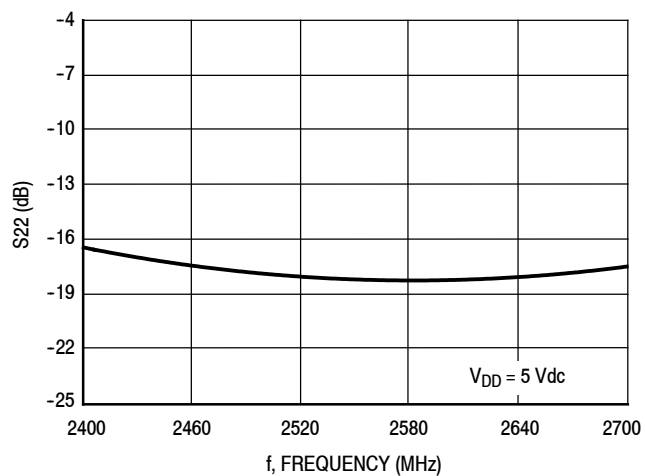

Figure 18. S22 versus Frequency

50 OHM TYPICAL CHARACTERISTICS: 2535 MHz

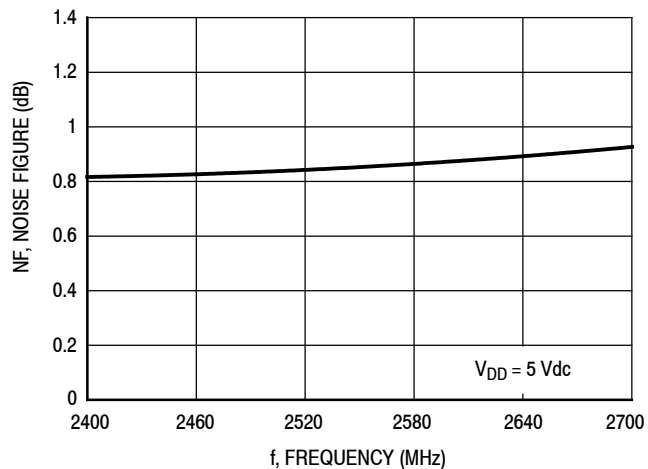

Figure 19. Noise Figure versus Frequency

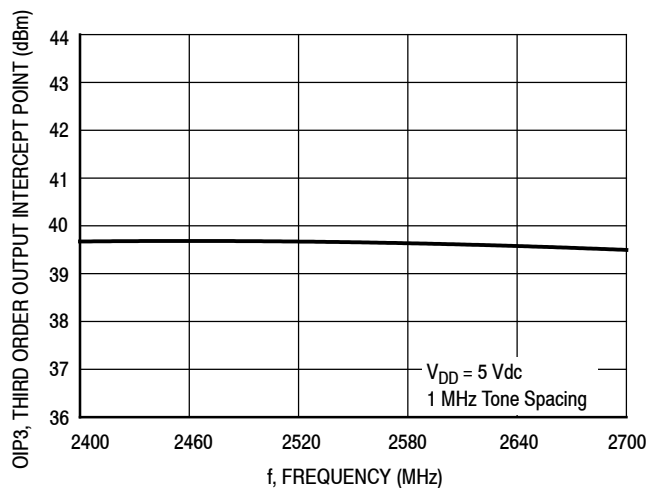

Figure 20. Third Order Output Intercept Point (Two-Tone) versus Frequency

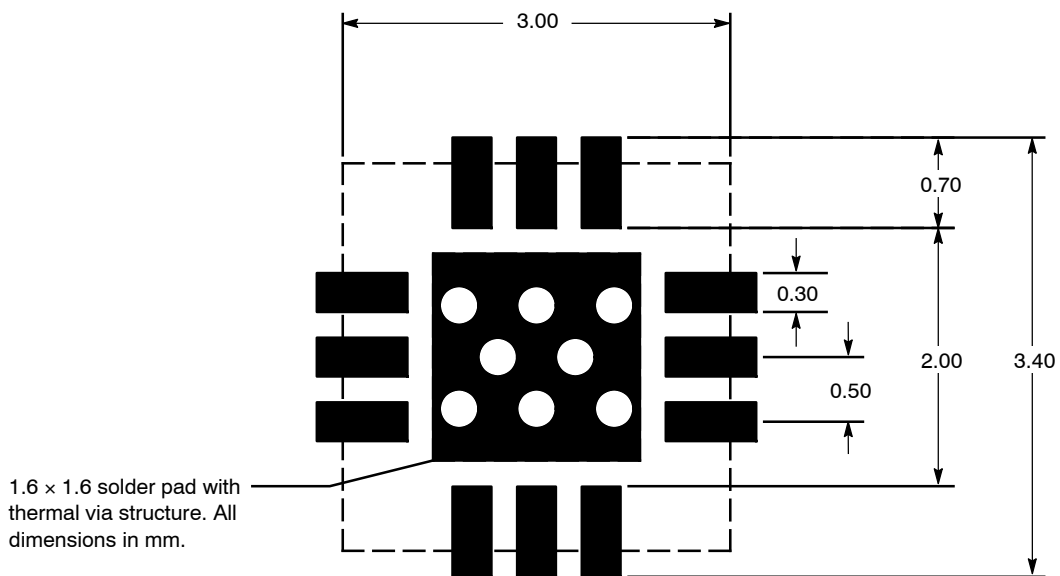
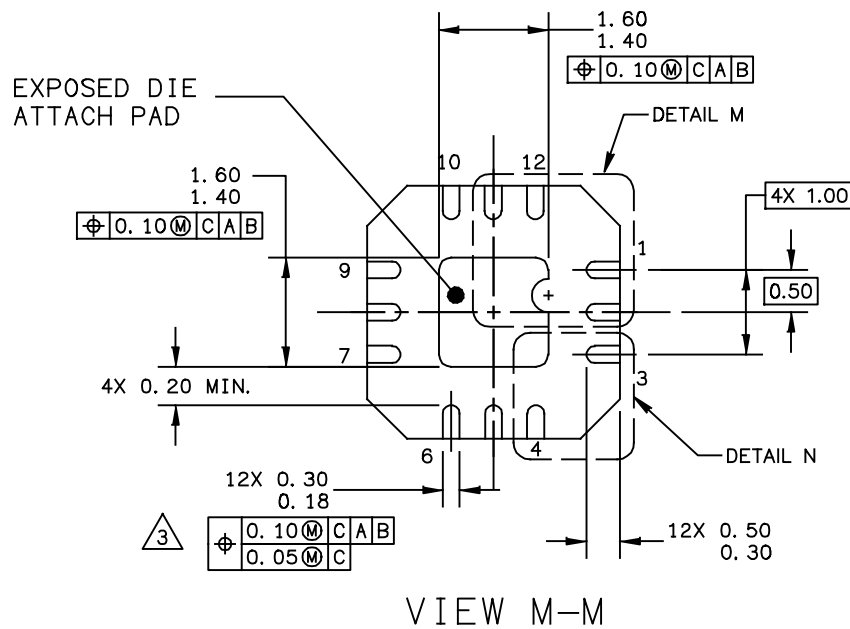
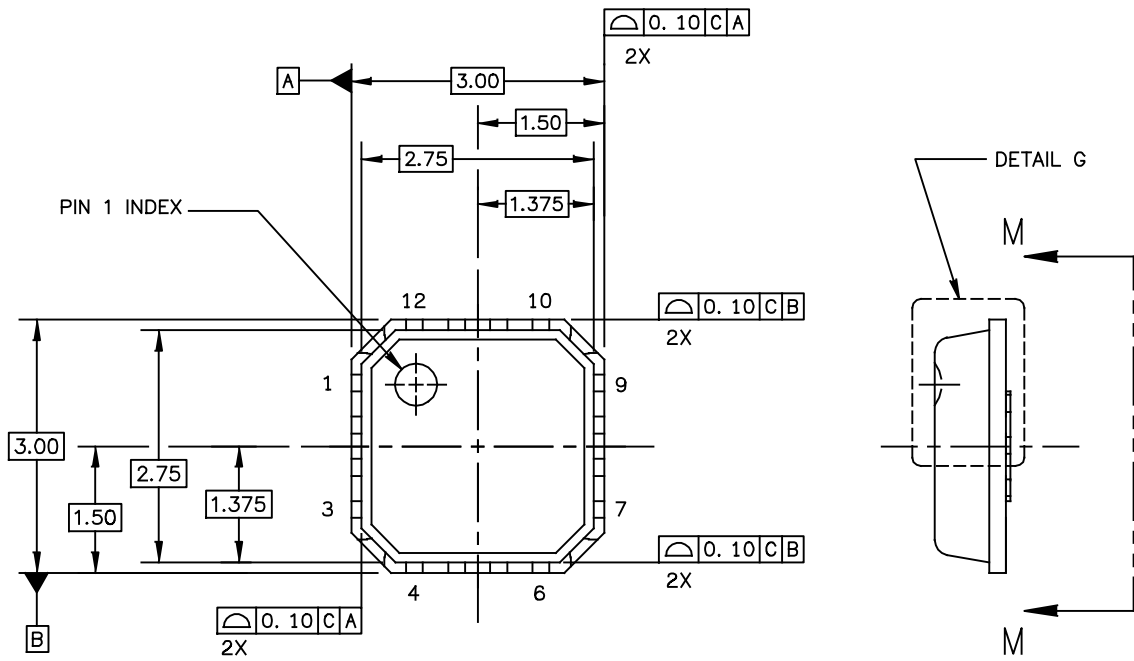

Figure 21. PCB Pad Layout for QFN 3 x 3

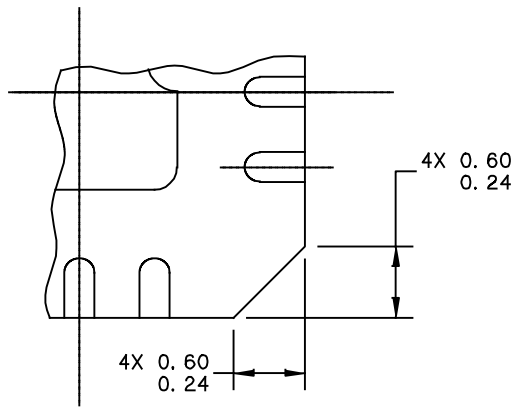

Figure 22. Product Marking

PACKAGE DIMENSIONS



© FREESCALE SEMICONDUCTOR, INC. ALL RIGHTS RESERVED.	MECHANICAL OUTLINE	PRINT VERSION NOT TO SCALE	
TITLE: THERMALLY ENHANCED QUAD FLAT NON-LEADED PACKAGE (QFN) 12 TERMINAL, 0.5 PITCH (3X3X0.85)	DOCUMENT NO: 98ASA00227D	REV: 0	
	CASE NUMBER: 2131-01	14 MAY 2010	
	STANDARD: NON-JEDEC		



DETAIL N
CORNER CONFIGURATION

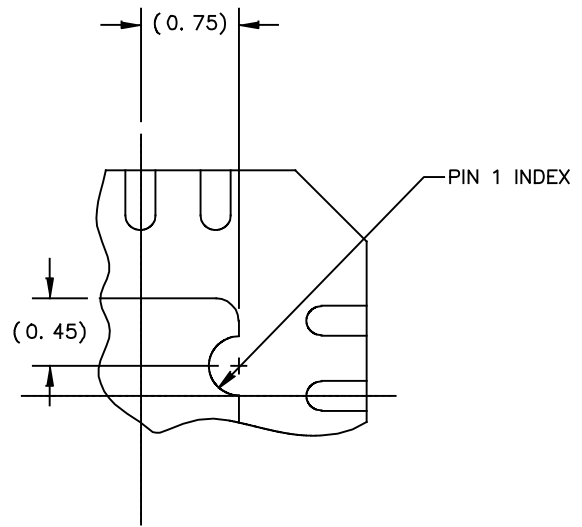

DETAIL M
PIN 1 BACKSIDE INDEX

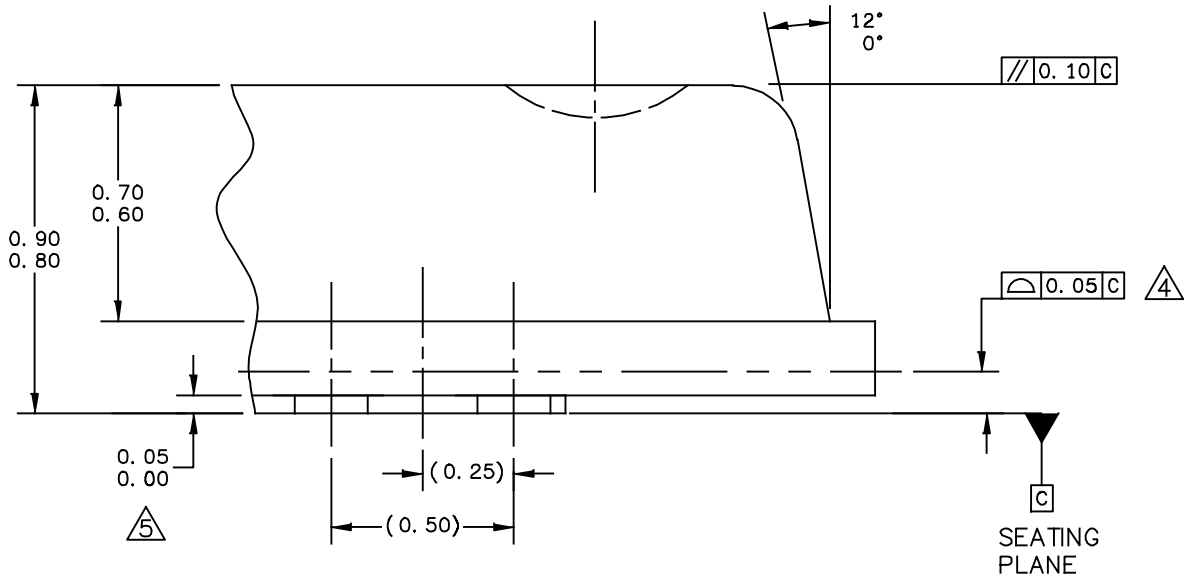

DETAIL G
VIEW ROTATED 90° CW

© FREESCALE SEMICONDUCTOR, INC. ALL RIGHTS RESERVED.	MECHANICAL OUTLINE	PRINT VERSION NOT TO SCALE	
TITLE: THERMALLY ENHANCED QUAD FLAT NON-LEADED PACKAGE (QFN) 12 TERMINAL, 0.5 PITCH (3X3X0.85)	DOCUMENT NO: 98ASA00227D	REV: 0	
	CASE NUMBER: 2131-01	14 MAY 2010	
	STANDARD: NON-JEDEC		

NOTE:

1. ALL DIMENSIONS ARE IN MILLIMETERS.
2. DIMENSIONING & TOLERANCING PER ASME Y14.5 – 2009.
3. THIS DIMENSION APPLIES TO PLATED TERMINAL AND IS MEASURED BETWEEN 0.15 AND 0.30 MM FROM TERMINAL TIP.
4. BILATERAL COPLANARITY ZONE APPLIES TO THE EXPOSED PAD AS WELL AS THE TERMINALS.
5. THIS DIMENSION APPLIED ONLY FOR TERMINALS.

© FREESCALE SEMICONDUCTOR, INC. ALL RIGHTS RESERVED.	MECHANICAL OUTLINE	PRINT VERSION NOT TO SCALE	
TITLE: THERMALLY ENHANCED QUAD FLAT NON-LEADED PACKAGE (QFN) 12 TERMINAL, 0.5 PITCH (3X3X0.85)	DOCUMENT NO: 98ASA00227D	REV: 0	
	CASE NUMBER: 2131-01	14 MAY 2010	
	STANDARD: NON-JEDEC		

APPENDIX: APPLICATION CIRCUITS WITH TWO-SUPPLY VOLTAGE

50 OHM APPLICATION CIRCUIT: 1950 MHz

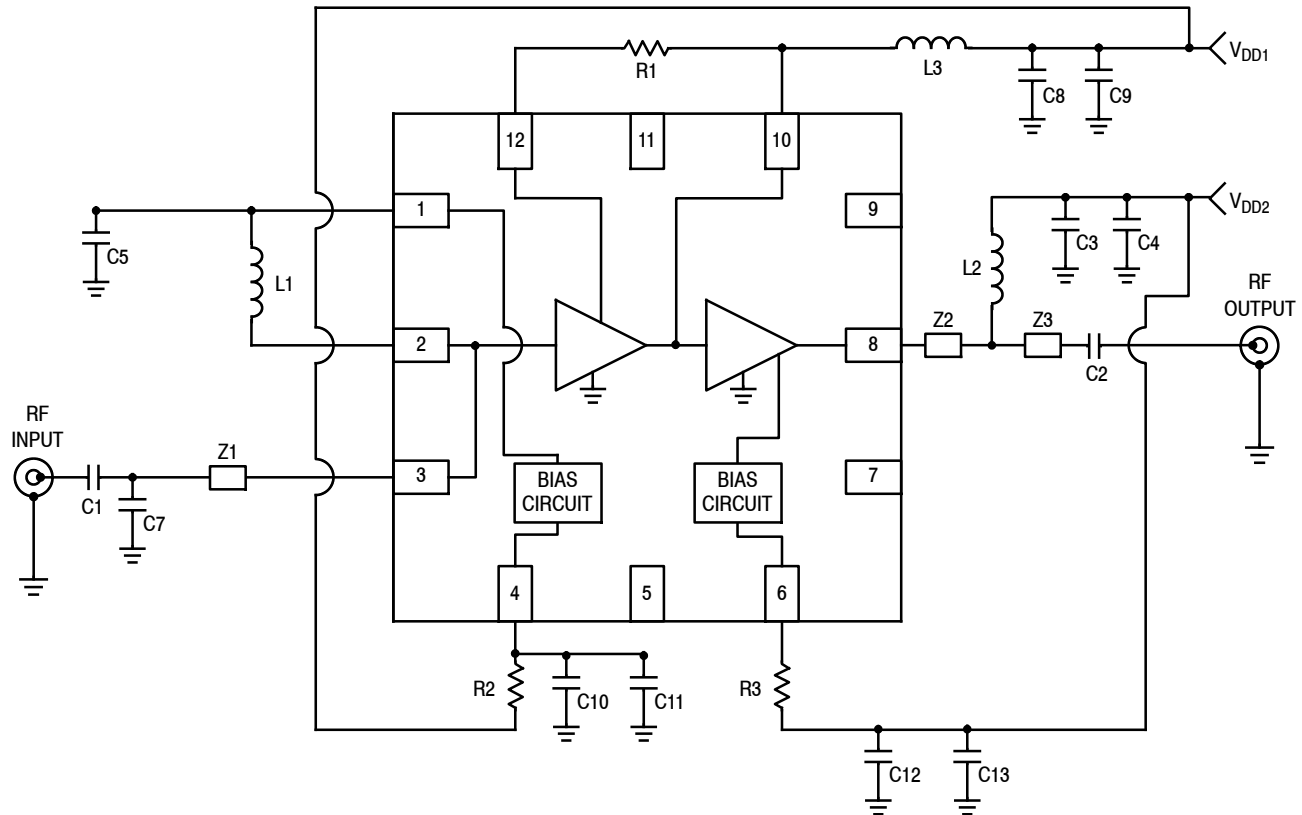

- Z1 0.248" × 0.021" Microstrip
- Z2 0.050" × 0.021" Microstrip
- Z3 0.030" × 0.021" Microstrip

Figure A-1. MML20242HT1 Test Circuit Schematic

Table A-1. MML20242HT1 Test Circuit Component Designations and Values

Part	Description	Part Number	Manufacturer
C1, C5	18 pF Chip Capacitors	GJM1555C1H180GB01	Murata
C2, C3, C8, C11, C12	18 pF Chip Capacitors	GRM1555C1H180JA01	Murata
C4, C9, C10, C13	0.1 μ F Chip Capacitors	GRM155R61A104K01	Murata
C6	Component Not Placed		
C7	0.6 pF Chip Capacitor	GJM1555C1HR60WB01	Murata
L1	3.3 nH Chip Inductor	0402HP-3N3XJLW	Coilcraft
L2	10 nH Chip Inductor	0402CS-10NXJLW	Coilcraft
L3	2.2 nH Chip Inductor	0402CS-2N2XJLW	Coilcraft
R1	180 Ω Chip Resistor	RC0402FR-07-180RL	Yageo
R2, R3	1200 Ω Chip Resistors	RC0402FR-07-1K2RL	Yageo
PCB	0.010", $\epsilon_r = 3.48$, Multilayer	RO4350B	Rogers

Note: Component number C6 is labeled on board but not placed.

50 OHM APPLICATION CIRCUIT: 1950 MHz

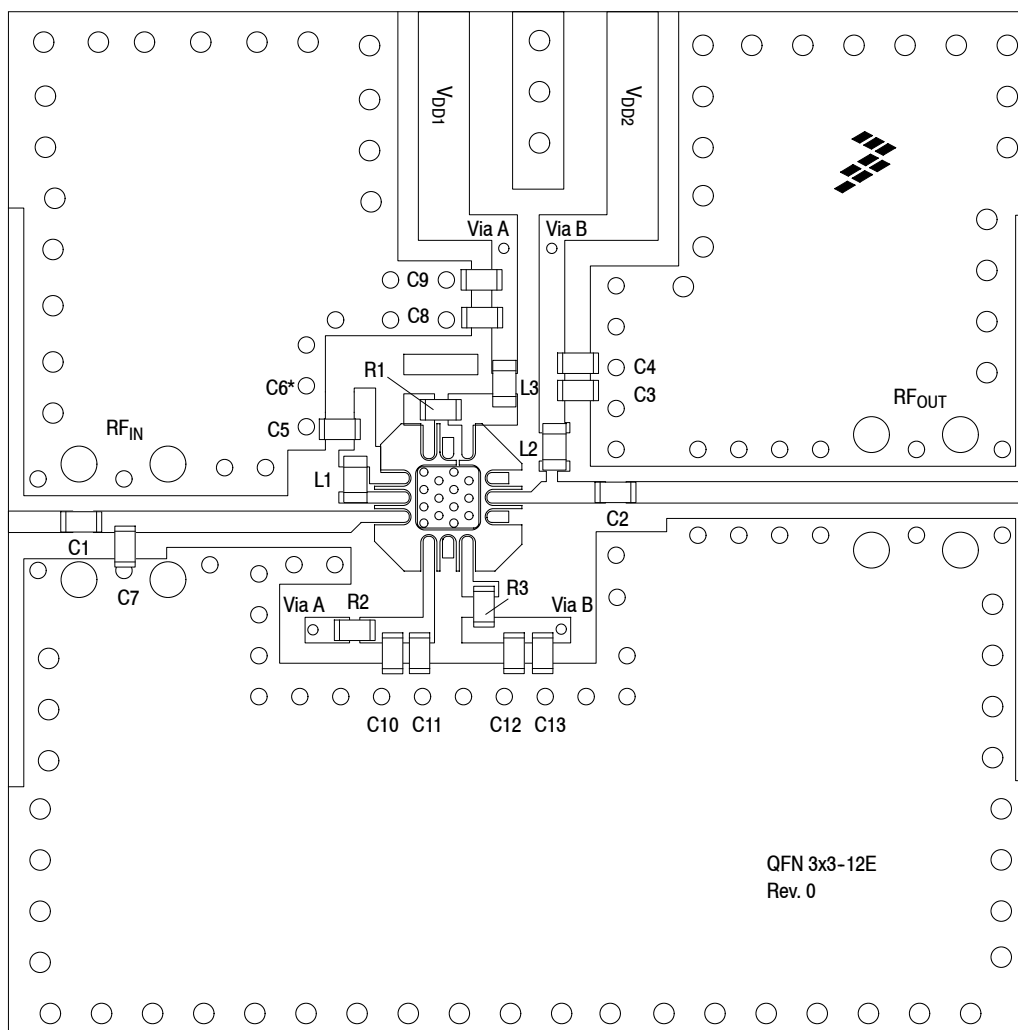

Note: Component number C6* is labeled on board but not placed.

Figure A-2. MML20242HT1 Test Circuit Component Layout

Table A-1. MML20242HT1 Test Circuit Component Designations and Values

Part	Description	Part Number	Manufacturer
C1, C5	18 pF Chip Capacitors	GJM1555C1H180GB01	Murata
C2, C3, C8, C11, C12	18 pF Chip Capacitors	GRM1555C1H180JA01	Murata
C4, C9, C10, C13	0.1 μ F Chip Capacitors	GRM155R61A104K01	Murata
C6	Component Not Placed		
C7	0.6 pF Chip Capacitor	GJM1555C1HR60WB01	Murata
L1	3.3 nH Chip Inductor	0402HP-3N3XJLW	Coilcraft
L2	10 nH Chip Inductor	0402CS-10NXJLW	Coilcraft
L3	2.2 nH Chip Inductor	0402CS-2N2XJLW	Coilcraft
R1	180 Ω Chip Resistor	RC0402FR-07-180RL	Yageo
R2, R3	1200 Ω Chip Resistors	RC0402FR-07-1K2RL	Yageo
PCB	0.010", $\epsilon_r = 3.48$, Multilayer	RO4350B	Rogers

(Test Circuit Component Designations and Values repeated for reference.)

50 OHM APPLICATION CIRCUIT: 2535 MHz

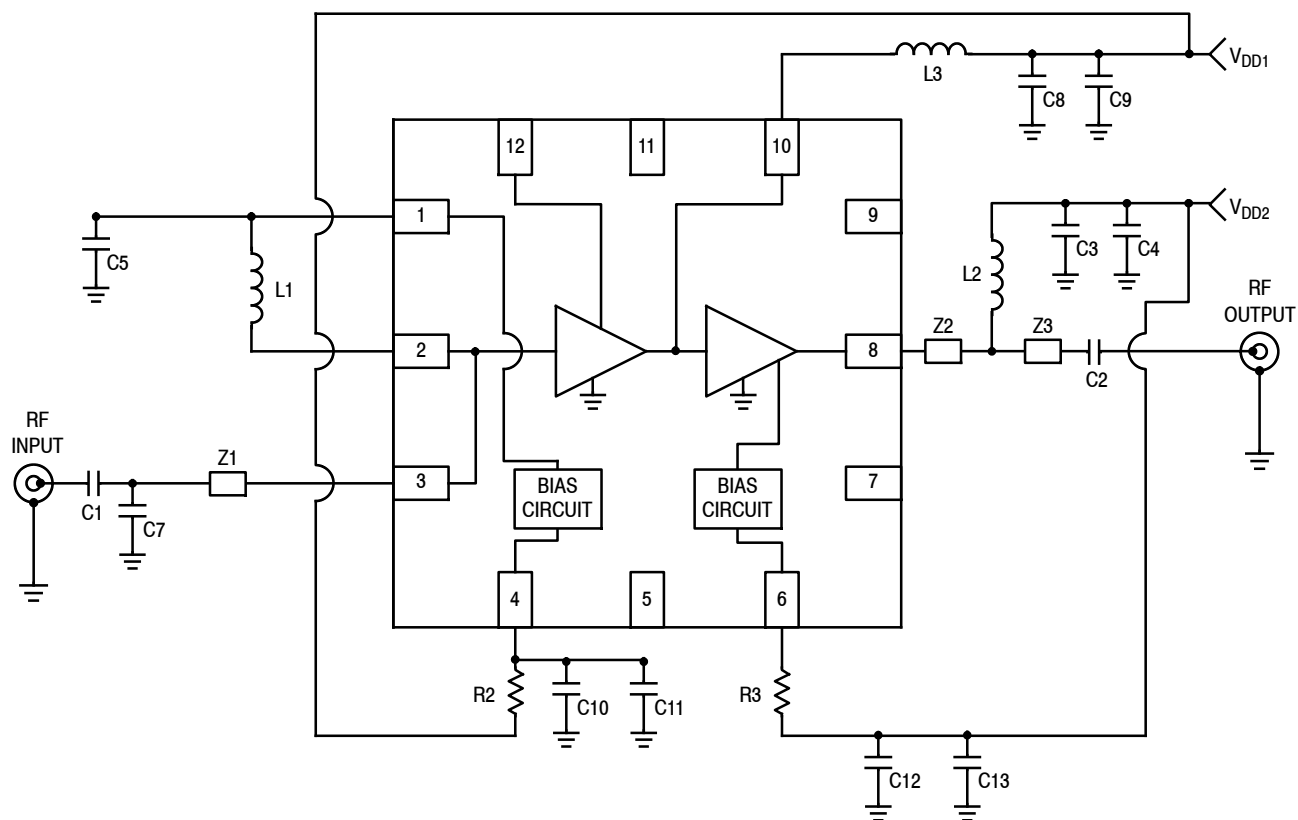

- Z1 0.248" × 0.021" Microstrip
- Z2 0.050" × 0.021" Microstrip
- Z3 0.030" × 0.021" Microstrip

Figure A-3. MML20242HT1 Test Circuit Schematic

Table A-2. MML20242HT1 Test Circuit Component Designations and Values

Part	Description	Part Number	Manufacturer
C1, C5	18 pF Chip Capacitors	GJM1555C1H180GB01	Murata
C2, C3, C8, C11, C12	18 pF Chip Capacitors	GRM1555C1H180JA01	Murata
C4, C9, C10, C13	0.1 μF Chip Capacitors	GRM155R61A104K01	Murata
C6	Component Not Placed		
C7	0.6 pF Chip Capacitor	GJM1555C1HR60WB01	Murata
L1	2.7 nH Chip Inductor	0402HP-2N7XJLW	Coilcraft
L2	6.8 nH Chip Inductor	0402CS-6N8XJLW	Coilcraft
L3	1.0 nH Chip Inductor	0402CS-1N0XJLW	Coilcraft
R1	Component Not Placed		
R2, R3	1200 Ω Chip Resistors	RC0402FR-07-1K2RL	Yageo
PCB	0.010", ε _r = 3.48, Multilayer	RO4350B	Rogers

Note: Component numbers C6 and R1 are labeled on board but not placed.

50 OHM APPLICATION CIRCUIT: 2535 MHz

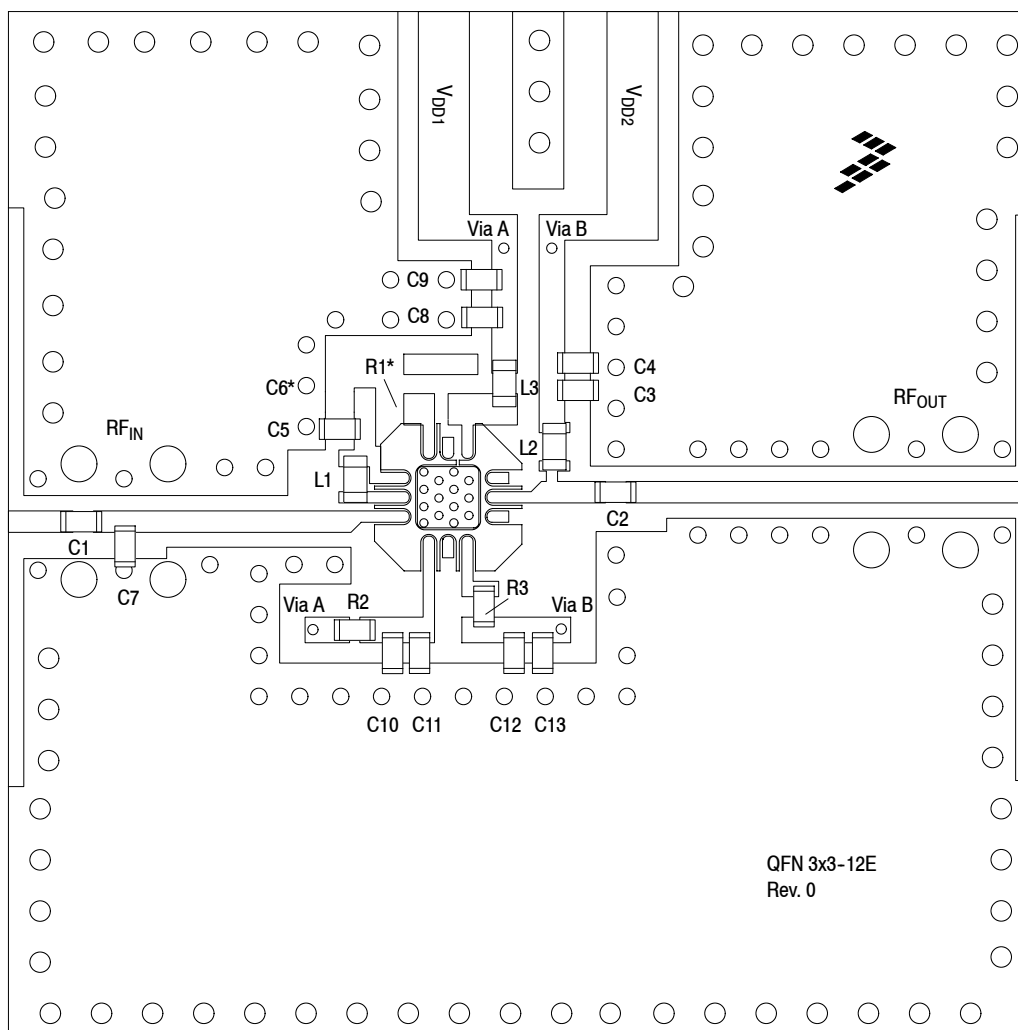

Note: Component number C6* and R1* are labeled on board but not placed.

Figure A-4. MML20242HT1 Test Circuit Component Layout

Table A-2. MML20242HT1 Test Circuit Component Designations and Values

Part	Description	Part Number	Manufacturer
C1, C5	18 pF Chip Capacitors	GJM1555C1H180GB01	Murata
C2, C3, C8, C11, C12	18 pF Chip Capacitors	GRM1555C1H180JA01	Murata
C4, C9, C10, C13	0.1 μ F Chip Capacitors	GRM155R61A104K01	Murata
C6	Component Not Placed		
C7	0.6 pF Chip Capacitor	GJM1555C1HR60WB01	Murata
L1	2.7 nH Chip Inductor	0402HP-2N7XJLW	Coilcraft
L2	6.8 nH Chip Inductor	0402CS-6N8XJLW	Coilcraft
L3	1.0 nH Chip Inductor	0402CS-1N0XJLW	Coilcraft
R1	Component Not Placed		
R2, R3	1200 Ω Chip Resistors	RC0402FR-07-1K2RL	Yageo
PCB	0.010", $\epsilon_r = 3.48$, Multilayer	RO4350B	Rogers

(Test Circuit Component Designations and Values repeated for reference.)

Refer to the following resources to aid your design process.

Application Notes

- AN1955: Thermal Measurement Methodology of RF Power Amplifiers
- AN3100: General Purpose Amplifier and MMIC Biasing

Software

- .s2p File

Development Tools

- Printed Circuit Boards

For Software and Tools, do a Part Number search at <http://www.freescale.com>, and select the “Part Number” link. Go to Software & Tools on the part’s Product Summary page to download the respective tool.

FAILURE ANALYSIS

At this time, because of the physical characteristics of the part, failure analysis is limited to electrical signature analysis. In cases where Freescale is contractually obligated to perform failure analysis (FA) services, full FA may be performed by third party vendors with moderate success. For updates contact your local Freescale Sales Office.

REVISION HISTORY

The following table summarizes revisions to this document.

Revision	Date	Description
0	Oct. 2012	<ul style="list-style-type: none"> • Initial Release of Data Sheet
1	Apr. 2013	<ul style="list-style-type: none"> • Features bullet for noise figure value: changed from 0.57 dB to 0.59 dB to reflect the true capability of the device, p. 1 • Table 1, Typical Performance: changed 1950 MHz noise figure from 0.57 dB to 0.59 dB and 2800 MHz noise figure from 0.89 dB to 0.97 dB to reflect the true capability of the device, p. 1 • Added 1950 MHz, 50 Ohm Operation, application circuit figures as follows: <ul style="list-style-type: none"> - Fig. 5, S11 versus Frequency versus Temperature, p. 5 - Fig. 6, S12 versus Frequency versus Temperature, p. 5 - Fig. 7, S21 versus Frequency versus Temperature, p. 5 - Fig. 8, S22 versus Frequency versus Temperature, p. 5 - Fig. 9, Noise Figure versus Frequency versus Temperature, p. 6 - Fig. 10, Power Gain versus Output Power versus Temperature, CW, p. 6 - Fig. 11, Third Order Output Intercept Point (Two-Tone) versus Frequency versus Temperature, p. 6 - Fig. 12, P1dB versus Frequency versus Temperature, CW, p. 6 • Added 2535 MHz, 50 Ohm Operation, application circuit figures as follows: <ul style="list-style-type: none"> - Fig. 15, S11 versus Frequency, p. 9 - Fig. 16, S12 versus Frequency, p. 9 - Fig. 17, S21 versus Frequency, p. 9 - Fig. 18, S22 versus Frequency, p. 9 - Fig. 19, Noise Figure versus Frequency, p. 10 - Fig. 20, Third Order Output Intercept Point (Two-Tone) versus Frequency, p. 10 • Added Appendix: Application Circuits with Two-Supply Voltage, pp. 15–18
2	Sept. 2014	<ul style="list-style-type: none"> • Table 2, Maximum Ratings: added footnote to RF Input Power to indicate which test signal was used to derive the max ratings value and updated Junction Temperature from 150°C to 175°C to reflect recent test results of the device, p. 1 • Added Failure Analysis information, p. 19

How to Reach Us:

Home Page:
freescale.com

Web Support:
freescale.com/support

Information in this document is provided solely to enable system and software implementers to use Freescale products. There are no express or implied copyright licenses granted hereunder to design or fabricate any integrated circuits based on the information in this document.

Freescale reserves the right to make changes without further notice to any products herein. Freescale makes no warranty, representation, or guarantee regarding the suitability of its products for any particular purpose, nor does Freescale assume any liability arising out of the application or use of any product or circuit, and specifically disclaims any and all liability, including without limitation consequential or incidental damages. "Typical" parameters that may be provided in Freescale data sheets and/or specifications can and do vary in different applications, and actual performance may vary over time. All operating parameters, including "typicals," must be validated for each customer application by customer's technical experts. Freescale does not convey any license under its patent rights nor the rights of others. Freescale sells products pursuant to standard terms and conditions of sale, which can be found at the following address: freescale.com/SalesTermsandConditions.

Freescale and the Freescale logo are trademarks of Freescale Semiconductor, Inc., Reg. U.S. Pat. & Tm. Off. All other product or service names are the property of their respective owners.

© 2012–2014 Freescale Semiconductor, Inc.

Looking for pricing, stock, or lifecycle information?

Click below to explore more details on WIN SOURCE:

 [View MML20242HT1 on WIN SOURCE](#)

 [NXP / Nexperia Information](#)

Optimize Your Supply Chain with WIN SOURCE Solutions

-  Global Sourcing Solution
-  Obsolete Management
-  Cost Control Management
-  Shortage Management
-  Alternative Solution
-  Excess Inventory Management