



THE DATASHEET OF MPC5748G-GW-RDB



Secure Automotive Ethernet Gateway Reference Design based on the MPC574xB/C/G Microcontrollers

For rapid prototyping and development of Automotive and Industrial Gateway Applications

Overview

The MPC5748G-GW-RDB is a reference design that provides A-sample like Ethernet Gateway ECU development system including board hardware and software enablement.

It features the 32-bit MPC5748G automotive MCU based on Power Architecture® technology. It offers up to three e200 Cores, Hardware Security Module, vast number of communication interfaces and flexible memory options.

The MPC5748G-GW-RDB reference design combines advanced NXP products to help accelerate customers' gateway product development and time to market.

Technical Highlights

1. Supports domain-based networking architectures
2. Multi-channels of 100BASE-T1 Ethernet and CAN FD (up to 5 Mbps)
3. HSM and secure Over-The-Air updates support
4. ISO 26262 support by using safety components and architecture.

MPC5748G MCU Specifications

Flash	Up to 6 MB	Timer/PWM	Up to 96-ch, eMIOS
SCI/SPI	Up to 768 KB	Other Timer	Up to 16 PIT, 3 STM, 4 SWT
Core	2 x Z4 @ 160 MHz 1 x Z2 @ 80 MHz	Analog	Up to 2 ADC (10 & 12-bit), 3 Comparators, CTU
Op Range	3.3 to 5.5 V	Communications	2 x ENET, 8 CAN FD 1 x SDHC, 1 x USB Up to 4 DSPI, 6 SPI, 18 LIN
Temp	-40 to 125 °C	Safety and Security	HSM (EVITA Medium), PASS, TDM, FCCU, ASIL B
Package	176 LQFP 256/324 BGA	Low Power	LPU_SLEEP, LPU_STOP LPU_STANDBY

System Block Diagram

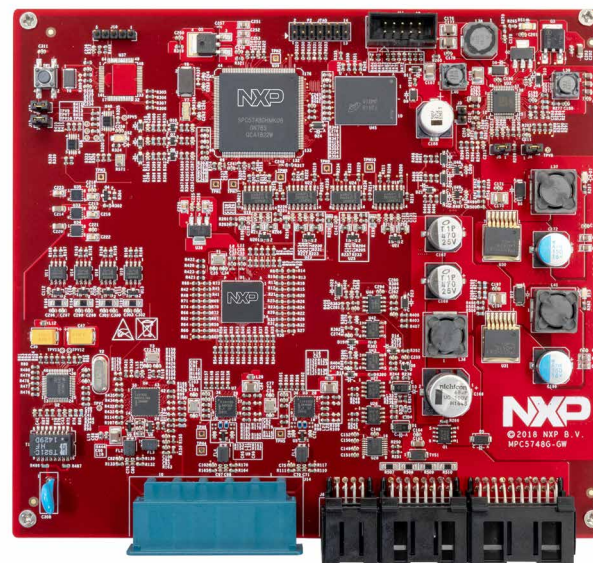
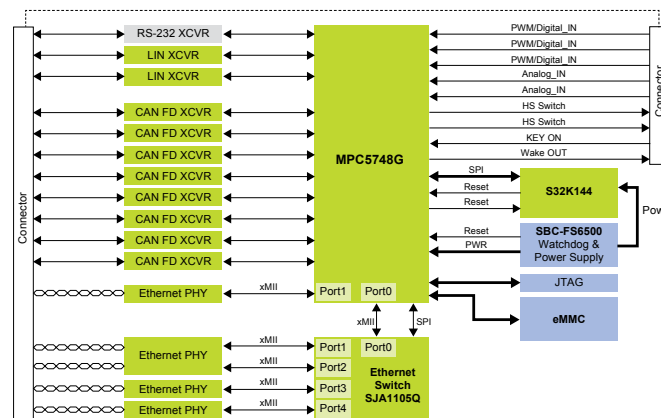

Features

- ▶ A-sample like central gateway ECU with MPC5748G (176 LQFP) onboard
- ▶ Supports multi-channels of automotive Ethernet and CAN FD
- ▶ Supports secure Over-The-Air updates with 4 GB eMMC onboard
- ▶ Hardware features:
 - 4 x 100BASE-T1 Ethernet
 - 1 x 100BASE-TX Ethernet for DoIP
 - 8 x CAN/CAN FD (up to 5 Mbps)
 - 2 x FlexLIN / 1 x RS-232
 - 3 x PWM / 2 x ADC / 2 x High-side switch out
 - JTAG debug
- ▶ Support functional safety features onboard:
 - ASIL D safety power SBC
 - ASIL B S32K144 as sub-MCU
 - ASIL A SJA1105Q 5-ports Ethernet switch
 - Fault management and reset logics circuits

Software and Tools

- ▶ S32 Design Studio and Software Development Kit
- ▶ AUTOSAR OS and MCAL
- ▶ Supports secure OTA with 4 GB eMMC onboard
- ▶ Runtime Software:
 - Flash and EEPROM driver
 - Software core self-test
- ▶ Compiler: Green Hills, Wind River, High Tec
- ▶ Debugger: Lauterbach, iSystem, PLS, Green Hills, P&E

www.nxp.com/MPC5748G-GW-RDB

NXP, the NXP logo and CodeWarrior are trademarks of NXP B.V. All other product or service names are the property of their respective owners. The Power Architecture and Power.org word marks and the Power and Power.org logos and related marks are trademarks and service marks licensed by Power.org. © 2019 NXP B.V.

Document Number: MPC5748GGWFS44 REV 1



Looking for pricing, stock, or lifecycle information?

Click below to explore more details on WIN SOURCE:

 [View MPC5748G-GW-RDB on WIN SOURCE](#)

 [NXP / Nexperia Information](#)

Optimize Your Supply Chain with WIN SOURCE Solutions

-  Global Sourcing Solution
-  Obsolete Management
-  Cost Control Management
-  Shortage Management
-  Alternative Solution
-  Excess Inventory Management