



**THE DATASHEET OF
MPVZ12GC6U**



10 kPa Uncompensated Silicon Pressure Sensors

The MPVZ12 series is a silicon piezoresistive pressure sensor providing a very accurate and linear voltage output — directly proportional to the applied pressure. This standard, low cost, uncompensated sensor permits manufacturers to design and add their own external temperature compensating and signal conditioning networks. Compensation techniques are simplified because of the predictability of Freescale's single element strain gauge design.

Features

- Low Cost
- Patented Silicon Shear Stress Strain Gauge Design
- Ratiometric to Supply Voltage
- Easy to Use Chip Carrier Package Options
- Differential and Gauge Options
- Durable Epoxy Package
- Increased media compatibility fluorocarbon gel

Application Examples

- Air Movement Control
- Environmental Control Systems
- Level Indicators
- Leak Detection
- Medical Instrumentation
- Industrial Controls
- Pneumatic Control Systems
- Robotics

ORDERING INFORMATION ⁽¹⁾				
Device Type	Options	Case No.	Order Number	Device Marking
Ported	Gauge	482A	MPVZ12GC6U	MPVZ12G
		482C	MPVZ12GC7U	MPVZ12G
		1735	MPVZ12GW6U	MZ12GW
		1560	MPVZ12GW7U	MZ12GW

1. MPVZ12 series pressure sensors are available in differential and gauge configurations. Devices are available in the basic element package or with pressure port fittings which provide printed circuit board mounting ease and barbed hose pressure connections.

MPVZ12 SERIES

UNCOMPENSATED PRESSURE SENSOR
0 TO 10 kPa (0–1.45 psi)
55 mV FULL SCALE SPAN (TYPICAL)

SMALL OUTLINE PACKAGE

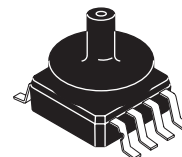

MPVZ12GC6U
 CASE 482A-01

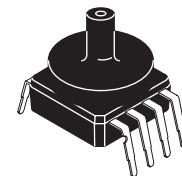

MPVZ12GC7U
 CASE 482C-03

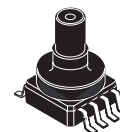

MPVZ12GW6U
 CASE 1735-01

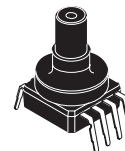

MPVZ12GW7U
 CASE 1560-02

PIN NUMBERS

1	GND	5	N/C
2	+V _{out}	6	N/C
3	V _s	7	N/C
4	-V _{out}	8	N/C

NOTE: Pin 1 is noted by the notch in the lead.

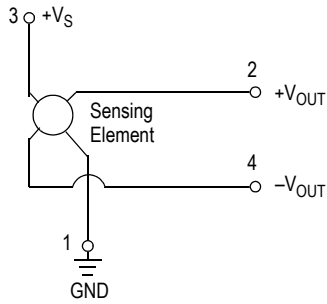

Figure 1. Uncompensated Pressure Sensor Schematic

VOLTAGE OUTPUT VERSUS APPLIED DIFFERENTIAL PRESSURE

The output voltage of the differential or gauge sensor increases with increasing pressure applied to the pressure side (P1) relative to the vacuum side (P2). Similarly, output

voltage increases as increasing vacuum is applied to the vacuum side (P2) relative to the pressure side (P1).

Table 1. Maximum Ratings⁽¹⁾

Rating	Symbol	Value	Unit
Maximum Pressure (P1 > P2)	P_{MAX}	75	kPa
Burst Pressure (P1 > P2)	P_{BURST}	100	kPa
Storage Temperature	T_{STG}	-40 to +125	°C
Operating Temperature	T_A	-40 to +125	°C

1. Exposure beyond the specified limits may cause permanent damage or degradation to the device.

Table 2. Operating Characteristics ($V_S = 3.0$ Vdc, $T_A = 25^\circ\text{C}$ unless otherwise noted, $P1 > P2$)

Characteristic	Symbol	Min	Typ	Max	Unit
Differential Pressure Range ⁽¹⁾	P_{OP}	0	—	10	kPa
Supply Voltage ⁽²⁾	V_S	—	3.0	6.0	Vdc
Supply Current	I_o	—	6.0	—	mAdc
Full Scale Span ⁽³⁾	V_{FSS}	45	55	70	mV
Offset ⁽⁴⁾	V_{off}	0	20	35	mV
Sensitivity	$\Delta V/\Delta P$	—	5.5	—	mV/kPa
Linearity ⁽⁵⁾	—	-0.5	—	5.0	% V_{FSS}
Pressure Hysteresis ⁶ (0 to 10 kPa)	—	—	± 0.1	—	% V_{FSS}
Temperature Hysteresis ⁽⁵⁾ (-40°C to $+125^\circ\text{C}$)	—	—	± 0.5	—	% V_{FSS}
Temperature Coefficient of Full Scale Span ⁽⁵⁾	TCV_{FSS}	-0.22	—	-0.16	% $V_{FSS}/^\circ\text{C}$
Temperature Coefficient of Offset ⁽⁵⁾	TCV_{off}	—	± 15	—	$\mu\text{V}/^\circ\text{C}$
Temperature Coefficient of Resistance ⁽⁵⁾	TCR	0.28	—	0.34	% $Z_{in}/^\circ\text{C}$
Input Impedance	Z_{in}	400	—	550	W
Output Impedance	Z_{out}	750	—	1250	W
Response Time ⁽⁶⁾ (10% to 90%)	t_R	—	1.0	—	ms
Warm-Up Time ⁽⁷⁾	—	—	20	—	ms
Offset Stability ⁽⁸⁾	—	—	± 0.5	—	% V_{FSS}

- 1.0 kPa (kiloPascal) equals 0.145 psi.
- Device is ratiometric within this specified excitation range. Operating the device above the specified excitation range may induce additional error due to device self-heating.
- Full Scale Span (V_{FSS}) is defined as the algebraic difference between the output voltage at full rated pressure and the output voltage at the minimum related pressure.
- Offset (V_{OFF}) is defined as the output voltage at the minimum rated pressure.
- Accuracy (error budget) consists of the following:
 - Linearity: Output deviation from a straight line relationship with pressure, using end point method, over the specified pressure range.
 - Temperature Hysteresis: Output deviation at any temperature within the operating temperature range, after the temperature is cycled to and from the minimum or maximum operating temperature points, with zero differential pressure applied.
 - Pressure Hysteresis: Output deviation at any pressure with the specified range, when this pressure is cycled to and from the minimum or maximum rated pressure at 25°C .
 - TcSpan: Output deviation at full rated pressure over the temperature range of 0 to 85°C , relative to 25°C .
 - TcOffset: Output deviation with minimum rated pressure applied, over the temperature range of 0 to 85°C , relative to 25°C .
 - TCR: Z_{IN} deviation with minimum rated pressure applied, over the temperature range of -40°C to $\pm 125^\circ\text{C}$, relative to 25°C .
- Response Time is defined as the time from the incremental change in the output to go from 10% to 90% of its final value when subjected to a specified step change in pressure.
- Warm-up Time is defined as the time required for the product to meet the specified output voltage after the pressure is stabilized.
- Offset stability is the product's output deviation when subjected to 1000 hours of Pulsed Pressure, Temperature Cycling with Bias Test.

TEMPERATURE COMPENSATION

Figure 2 shows the typical output characteristics of the MPVZ12 series over temperature.

Because this strain gauge is an integral part of the silicon diaphragm, there are no temperature effects due to differences in the thermal expansion of the strain gauge and the diaphragm, as are often encountered in bonded strain gauge pressure sensors. However, the properties of the strain gauge itself are temperature dependent, requiring that the device be temperature compensated if it is to be used over an extensive temperature range.

Temperature compensation and offset calibration can be achieved rather simply with additional resistive components, or by designing your system using the MPX2010D series sensor.

Several approaches to external temperature compensation over both -40 to $+125^{\circ}\text{C}$ and 0 to $+80^{\circ}\text{C}$ ranges are presented in Applications Note AN840.

LINEARITY

Linearity refers to how well a transducer's output follows the equation: $V_{\text{out}} = V_{\text{off}} + \text{sensitivity} \times P$ over the operating pressure range (Figure 3). There are two basic methods for calculating nonlinearity: (1) end point straight line fit or (2) a least squares best line fit. While a least squares fit gives the "best case" linearity error (lower numerical value), the calculations required are burdensome.

Conversely, an end point fit will give the "worst case" error (often more desirable in error budget calculations) and the calculations are more straightforward for the user. Freescale's specified pressure sensor linearities are based on the end point straight line method measured at the midrange pressure.

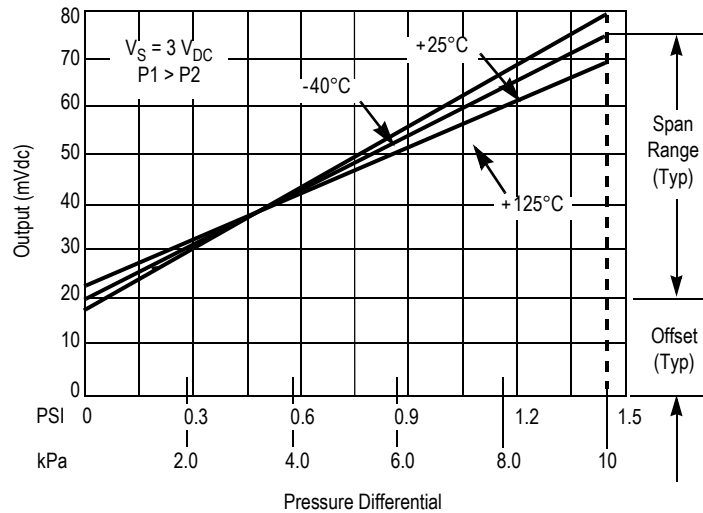

Figure 2. Output versus Pressure Differential

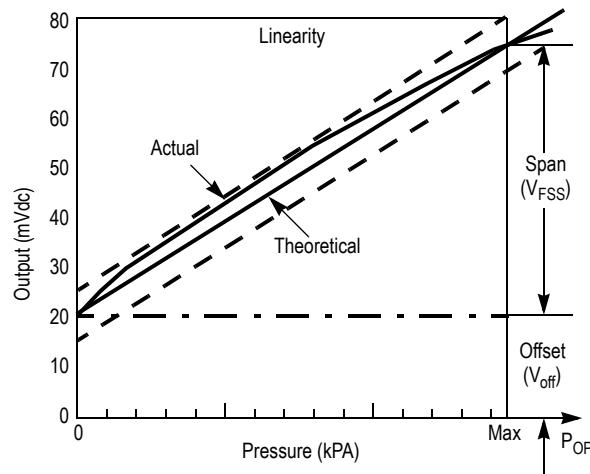

Figure 3. Linearity Specification Comparison

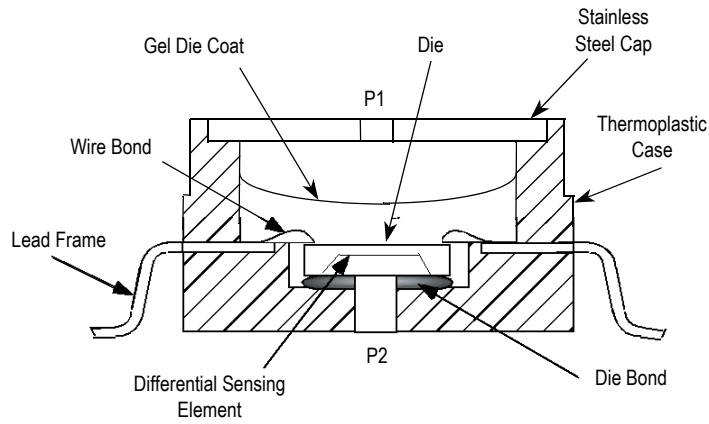

Figure 4. Cross-Sectional Diagram (not to scale)

Figure 4 illustrates the differential or gauge configuration in the basic chip carrier (applicable to cases 482, 1560 and 1735). A gel isolates the die surface and wire bonds from the environment, while allowing the pressure signal to be transmitted to the silicon diaphragm.

Operating characteristics, internal reliability and qualification tests are based on use of dry clean air as the pressure media. Media other than dry clean air may have adverse effects on sensor performance and long term reliability. Contact the factory for information regarding media compatibility in your application.

PRESSURE (P1)/VACUUM (P2) SIDE IDENTIFICATION TABLE

Freescale designates the two sides of the pressure sensor as the Pressure (P1) side and the Vacuum (P2) side. The Pressure (P1) side is the side containing gel which isolates the die from the environment. The Freescale MPVZ12 series is designed to operate with positive differential pressure applied, $P1 > P2$.

The Pressure (P1) side may be identified by using the following table

Part Number	Case Type	Pressure (P1) Side Identifier
MPVZ12GC6U	482A 98ASB17757C	Top with Port Attached
MPVZ12GC7U	482C 98ASB17759C	Top with Port Attached
MPVZ12GW6U	1735 98ASA10686D	Top with Port Attached
MPVZ12GW7U	1560 98ASA10611D	Top with Port Attached

PACKAGE DIMENSIONS

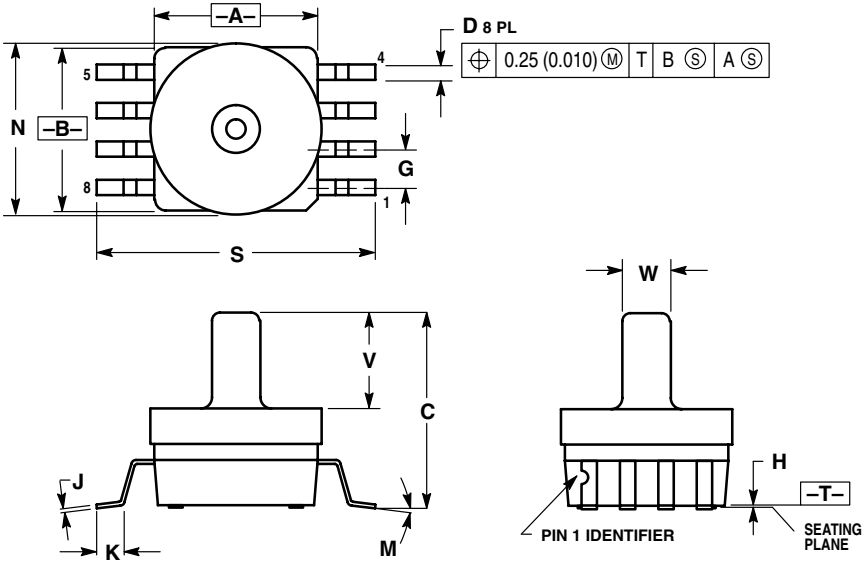

NOTES:

1. DIMENSIONING AND TOLERANCING PER ANSI Y14.5M, 1982.
2. CONTROLLING DIMENSION: INCH.
3. DIMENSION A AND B DO NOT INCLUDE MOLD PROTRUSION.
4. MAXIMUM MOLD PROTRUSION 0.15 (0.006).
5. ALL VERTICAL SURFACES 5° TYPICAL DRAFT.

DIM	INCHES		MILLIMETERS	
	MIN	MAX	MIN	MAX
A	0.415	0.425	10.54	10.79
B	0.415	0.425	10.54	10.79
C	0.500	0.520	12.70	13.21
D	0.038	0.042	0.96	1.07
G	0.100 BSC		2.54 BSC	
H	0.002	0.010	0.05	0.25
J	0.009	0.011	0.23	0.28
K	0.061	0.071	1.55	1.80
M	0°	7°	0°	7°
N	0.444	0.448	11.28	11.38
S	0.709	0.725	18.01	18.41
V	0.245	0.255	6.22	6.48
W	0.115	0.125	2.92	3.17

**CASE 482A-01
 ISSUE A
 SMALL OUTLINE PACKAGE**

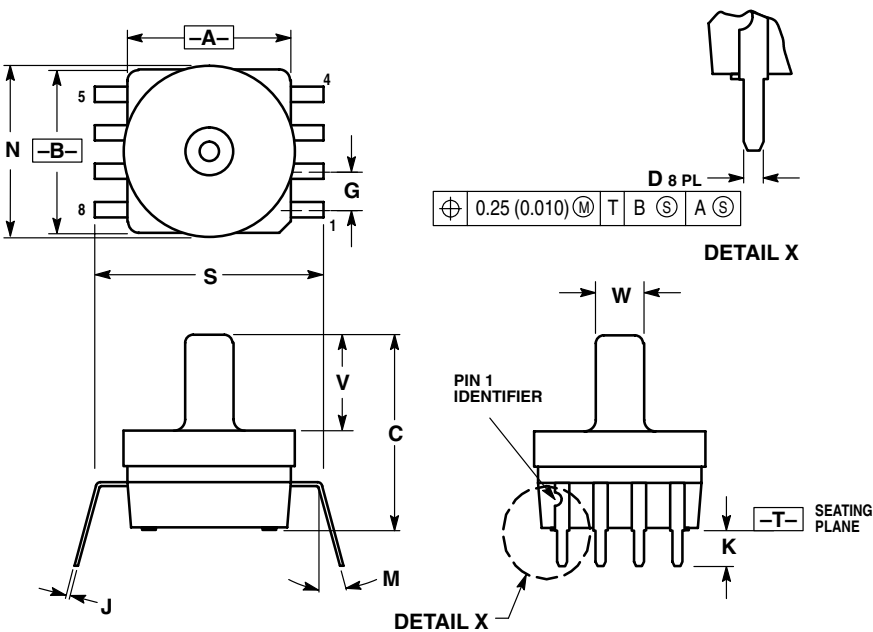

NOTES:

1. DIMENSIONING AND TOLERANCING PER ANSI Y14.5M, 1982.
2. CONTROLLING DIMENSION: INCH.
3. DIMENSION A AND B DO NOT INCLUDE MOLD PROTRUSION.
4. MAXIMUM MOLD PROTRUSION 0.15 (0.006).
5. ALL VERTICAL SURFACES 5° TYPICAL DRAFT.
6. DIMENSION S TO CENTER OF LEAD WHEN FORMED PARALLEL.

DIM	INCHES		MILLIMETERS	
	MIN	MAX	MIN	MAX
A	0.415	0.425	10.54	10.79
B	0.415	0.425	10.54	10.79
C	0.500	0.520	12.70	13.21
D	0.026	0.034	0.66	0.864
G	0.100 BSC		2.54 BSC	
J	0.009	0.011	0.23	0.28
K	0.100	0.120	2.54	3.05
M	0°	15°	0°	15°
N	0.444	0.448	11.28	11.38
S	0.540	0.560	13.72	14.22
V	0.245	0.255	6.22	6.48
W	0.115	0.125	2.92	3.17

**CASE 482C-03
 ISSUE B
 SMALL OUTLINE PACKAGE**

PACKAGE DIMENSIONS

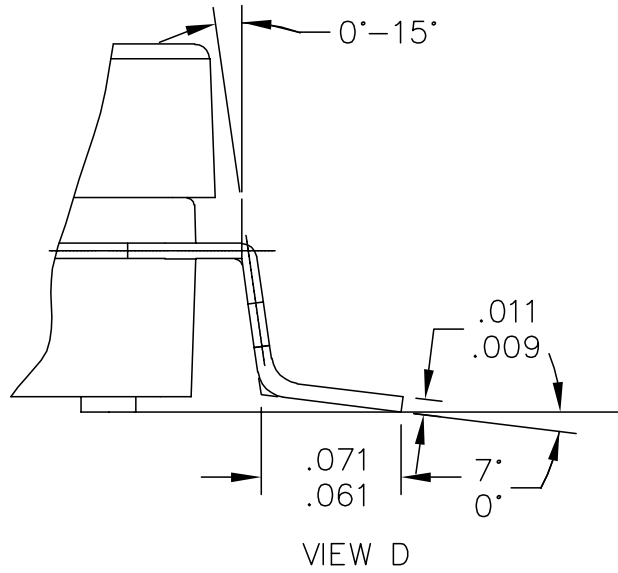

© FREESCALE SEMICONDUCTOR, INC. ALL RIGHTS RESERVED.	MECHANICAL OUTLINE	PRINT VERSION NOT TO SCALE	
TITLE: SO, 8 I/O, .420 X .420 PKG, .100 IN PITCH	DOCUMENT NO: 98ASA10686D	REV: A	
	CASE NUMBER: 1735-01	18 AUG 2005	
	STANDARD: NON-JEDEC		

**CASE 1735-01
ISSUE A
SMALL OUTLINE PACKAGE**

PACKAGE DIMENSIONS

NOTES:

1. DIMENSIONING AND TOLERANCING PER ASME Y14.5M – 1994.
2. CONTROLLING DIMENSION: INCH.
3. DIMENSIONS DO NOT INCLUDE MOLD PROTRUSION.
4. MAXIMUM MOLD PROTRUSION IS .006.
5. ALL VERTICAL SURFACES 5° TYPICAL DRAFT.
6. DIMENSION TO CENTER OF LEAD WHEN FORMED PARALLEL.

© FREESCALE SEMICONDUCTOR, INC. ALL RIGHTS RESERVED.	MECHANICAL OUTLINE	PRINT VERSION NOT TO SCALE
TITLE: SO, 8 I/O, .420 X .420 PKG, .100 IN PITCH	DOCUMENT NO: 98ASA10686D	REV: A
	CASE NUMBER: 1735-01	18 AUG 2005
	STANDARD: NON-JEDEC	

CASE 1735-01
ISSUE A
SMALL OUTLINE PACKAGE

PACKAGE DIMENSIONS

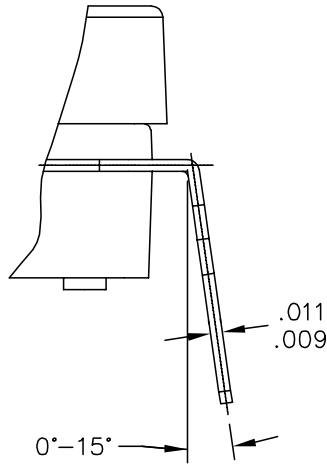

VIEW D

© FREESCALE SEMICONDUCTOR, INC. ALL RIGHTS RESERVED.	MECHANICAL OUTLINE	PRINT VERSION NOT TO SCALE	
TITLE: SO, 8 I/O, .420 X .420 PKG, .100 IN PITCH	DOCUMENT NO: 98ASA10611D	REV: C	
	CASE NUMBER: 1560-02	26 MAY 2005	
	STANDARD: NON-JEDEC		

**CASE 1560-02
ISSUE C
SMALL OUTLINE PACKAGE**

PACKAGE DIMENSIONS

NOTES:

1. DIMENSIONING AND TOLERANCING PER ASME Y14.5M – 1994.
2. CONTROLLING DIMENSION: INCH.
3. DIMENSIONS DO NOT INCLUDE MOLD PROTRUSION.
4. MAXIMUM MOLD PROTRUSION IS .006.
5. ALL VERTICAL SURFACES 5° TYPICAL DRAFT.
6. DIMENSION TO CENTER OF LEAD WHEN FORMED PARALLEL.

© FREESCALE SEMICONDUCTOR, INC. ALL RIGHTS RESERVED.	MECHANICAL OUTLINE	PRINT VERSION NOT TO SCALE	
TITLE: SO, 8 I/O, .420 X .420 PKG, .100 IN PITCH	DOCUMENT NO: 98ASA10611D	REV: C	
	CASE NUMBER: 1560-02	26 MAY 2005	
	STANDARD: NON-JEDEC		

CASE 1560-02
ISSUE C
SMALL OUTLINE PACKAGE

How to Reach Us:

Home Page:

www.freescale.com

Web Support:

<http://www.freescale.com/support>

USA/Europe or Locations Not Listed:

Freescale Semiconductor, Inc.
Technical Information Center, EL516
2100 East Elliot Road
Tempe, Arizona 85284
+1-800-521-6274 or +1-480-768-2130
www.freescale.com/support

Europe, Middle East, and Africa:

Freescale Halbleiter Deutschland GmbH
Technical Information Center
Schatzbogen 7
81829 Muenchen, Germany
+44 1296 380 456 (English)
+46 8 52200080 (English)
+49 89 92103 559 (German)
+33 1 69 35 48 48 (French)
www.freescale.com/support

Japan:

Freescale Semiconductor Japan Ltd.
Headquarters
ARCO Tower 15F
1-8-1, Shimo-Meguro, Meguro-ku,
Tokyo 153-0064
Japan
0120 191014 or +81 3 5437 9125
support.japan@freescale.com

Asia/Pacific:

Freescale Semiconductor Hong Kong Ltd.
Technical Information Center
2 Dai King Street
Tai Po Industrial Estate
Tai Po, N.T., Hong Kong
+800 2666 8080
support.asia@freescale.com

For Literature Requests Only:

Freescale Semiconductor Literature Distribution Center
P.O. Box 5405
Denver, Colorado 80217
1-800-441-2447 or 303-675-2140
Fax: 303-675-2150
LDCForFreescaleSemiconductor@hibbertgroup.com

Information in this document is provided solely to enable system and software implementers to use Freescale Semiconductor products. There are no express or implied copyright licenses granted hereunder to design or fabricate any integrated circuits or integrated circuits based on the information in this document.

Freescale Semiconductor reserves the right to make changes without further notice to any products herein. Freescale Semiconductor makes no warranty, representation or guarantee regarding the suitability of its products for any particular purpose, nor does Freescale Semiconductor assume any liability arising out of the application or use of any product or circuit, and specifically disclaims any and all liability, including without limitation consequential or incidental damages. "Typical" parameters that may be provided in Freescale Semiconductor data sheets and/or specifications can and do vary in different applications and actual performance may vary over time. All operating parameters, including "Typicals", must be validated for each customer application by customer's technical experts. Freescale Semiconductor does not convey any license under its patent rights nor the rights of others. Freescale Semiconductor products are not designed, intended, or authorized for use as components in systems intended for surgical implant into the body, or other applications intended to support or sustain life, or for any other application in which the failure of the Freescale Semiconductor product could create a situation where personal injury or death may occur. Should Buyer purchase or use Freescale Semiconductor products for any such unintended or unauthorized application, Buyer shall indemnify and hold Freescale Semiconductor and its officers, employees, subsidiaries, affiliates, and distributors harmless against all claims, costs, damages, and expenses, and reasonable attorney fees arising out of, directly or indirectly, any claim of personal injury or death associated with such unintended or unauthorized use, even if such claim alleges that Freescale Semiconductor was negligent regarding the design or manufacture of the part.

Freescale™ and the Freescale logo are trademarks of Freescale Semiconductor, Inc. All other product or service names are the property of their respective owners.

© Freescale Semiconductor, Inc. 2007. All rights reserved.



Looking for pricing, stock, or lifecycle information?

Click below to explore more details on WIN SOURCE:

 [View MPVZ12GC6U on WIN SOURCE](#)

 [NXP / Nexperia Information](#)

Optimize Your Supply Chain with WIN SOURCE Solutions

-  Global Sourcing Solution
-  Obsolete Management
-  Cost Control Management
-  Shortage Management
-  Alternative Solution
-  Excess Inventory Management