



**THE DATASHEET OF
MCZ79076EG**



Electronic Ignition Control Circuit

The 79076, in conjunction with an appropriate Freescale Power Darlington Transistor, provides an economical solution for automotive ignition applications. The 79076 offers optimum performance by providing closed loop operation of the Power Darlington in controlling the ignition coil current.

Features

- Hall or Variable Reluctance Sensor Input
- Ignition Coil Voltage Internally Limited to 375 V
- Coil Current Limiting to 7.5 A
- Output On-Time (Dwell) Control
- Dwell Feedback Control to Sense Coil Variation
- Pb-Free Packaging Designated by Suffix Code EG

79076

ELECTRONIC IGNITION CONTROL CIRCUIT



**DW SUFFIX
EG (PB-FREE) SUFFIX
98ASB42567B
16-PIN SOIC**

| ORDERING INFORMATION | | |
|----------------------|-------------------------------------|---------|
| Device | Temperature Range (T _A) | Package |
| MC79076DW/R2 | -30°C to 125°C | 16 SOIC |
| MCZ79076EG/R2 | | |

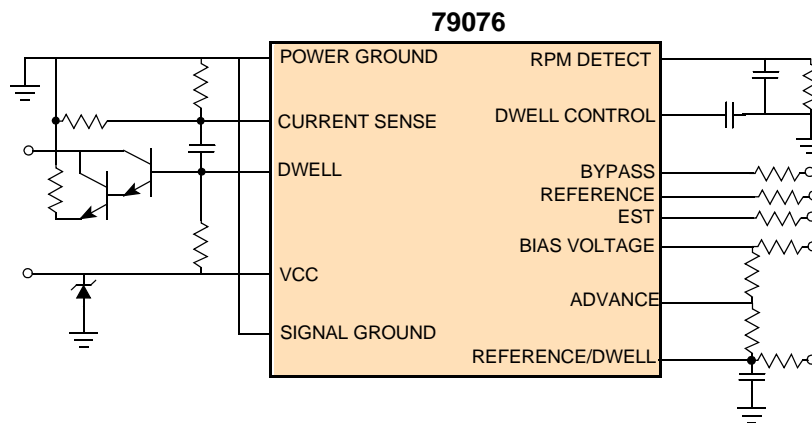

Figure 1. 79076 Simplified Application Diagram

INTERNAL BLOCK DIAGRAM

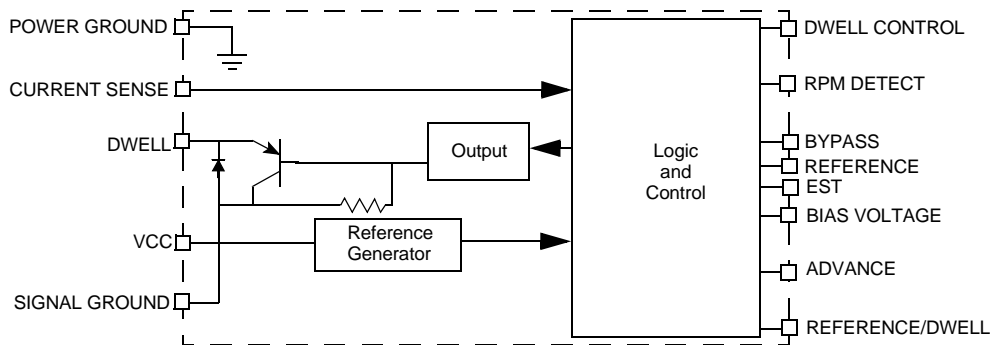

Figure 2. 79076 Simplified Internal Block Diagram

PIN CONNECTIONS

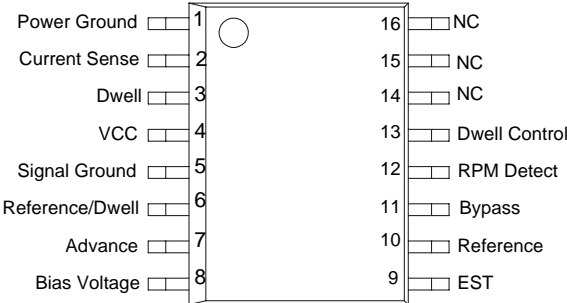

Figure 3. 79076 Pin Connections

ELECTRICAL CHARACTERISTICS

MAXIMUM RATINGS

Table 1. Maximum Ratings

All voltages are with respect to ground unless otherwise noted. Exceeding these ratings may cause a malfunction or permanent damage to the device.

| Ratings | Symbol | Value | Unit |
|---|----------------|------------|------|
| ELECTRICAL RATINGS | | | |
| Supply Voltage | | | V |
| Steady-State | $V_{CC(SUS)}$ | 36 | |
| Transient Conditions ⁽¹⁾ | $V_{CC(PK)}$ | 50 | |
| Supply Current | I_T | | A |
| Transient Conditions ⁽²⁾ | | 1.0 | A |
| Transient Negative Current ($t_T = 60ms$) | | -100 | mA |
| Transient Negative Current ($t_T = 1ms$) | | -1.3 | A |
| Input Voltage ⁽³⁾ | | | V |
| Ref/Dwell, Advance | V_{IN1} | -5.0 to 30 | |
| EST, Bypass | V_{IN2} | -5.0 to 24 | |
| Ref/Dwell Input Current | I_{IN1} | -20 | mA |
| Dwell ON Sink Current | I_D | | A |
| Output ON (Operating) | | 0.3 | |
| Output ON ($t = 10ms$) | | 0.8 | |
| Dwell OFF Voltage ⁽⁴⁾ | $V_{D(OFF)}$ | 5.0 | V |
| THERMAL RATINGS | | | |
| Storage Temperature | T_{STG} | -65 to 150 | °C |
| Operating Ambient Temperature | T_A | -30 to 125 | °C |
| THERMAL RESISTANCE | | | |
| Operating Junction Temperature | T_J | -30 to 150 | °C |
| Thermal Resistance (Junction-to-Ambient) - SO8 | θ_{J-A} | 80 | °C/W |
| Peak Package Reflow Temperature During Reflow ^{(5), (6)} | T_{PPRT} | Note 6 | °C |

Notes

- Survivability of device with transient voltage applied to V_{CC} pin for a duration not to exceed 10ms.
- Survivability of device with overvoltage applied to V_{CC} pin producing the current for a duration not to exceed 10ms.
- Exceeding this voltage range on the function pin may cause permanent damage to the device.
- A zener diode is incorporated across collector to emitter of the output NPN device to prevent voltage overdrive of the external Darlington switch transistor.
- Pin soldering temperature limit is for 10 seconds maximum duration. Not designed for immersion soldering. Exceeding these limits may cause malfunction or permanent damage to the device.
- Freescale's Package Reflow capability meets Pb-free requirements for JEDEC standard J-STD-020C. For Peak Package Reflow Temperature and Moisture Sensitivity Levels (MSL), Go to www.freescale.com, search by part number [e.g. remove prefixes/suffixes and enter the core ID to view all orderable parts. (i.e. MC33xxx enter 33xxx), and review parametrics.

STATIC ELECTRICAL CHARACTERISTICS

Table 2. Static Electrical Characteristics

Characteristics noted under conditions $7.0\text{ V} \leq V_{CC} \leq 18\text{ V}$, $-40^\circ\text{C} \leq T_A \leq 125^\circ\text{C}$, $\text{GND} = 0\text{ V}$ unless otherwise noted. Typical values noted reflect the approximate parameter means at $T_A = 25^\circ\text{C}$ under nominal conditions unless otherwise noted.

| Characteristic | Symbol | Min | Typ | Max | Unit |
|--|---|---|---|-------------------------|------------------|
| INPUTS | | | | | |
| Advance Input Resistance ($V_{CC} = 16\text{ V}$, Ref/Dwell = 1.0 V, Advance = 1.0 mA, EST = Bypass = 0 V) | $R_{(A)}$ | 15 | 18 | 25 | $\text{k}\Omega$ |
| Advance Voltage ⁽⁷⁾ $V_{CC} = 16\text{ V}$, Ref/Dwell = 1.0 V, EST = Bypass = 0 V | $V_{TH(A)}$ | - | 0.05 | 0.1 | V |
| Advance Threshold Voltage ⁽⁷⁾ ($V_{CC} = 16\text{ V}$, Ref/Dwell = 1.0 V, EST = Bypass = 0 V,) Dwell = Reference = RPM Detect = open, Dwell Control = sinking 10 μA) Increasing Decreasing Hysteresis | $V_{TH+(A)}$ $V_{TH-(A)}$ $V_{HYS(A)}$ | $V_B + 0.103$ $V_B + 0.045$ 0.018 | $V_B + 0.114$ $V_B + 0.068$ 0.045 | $V_B + 0.130$ - - | V |
| Bypass Input Resistance ($V_{CC} = 16\text{ V}$, Ref/Dwell = Advance = 3.0 V, EST = Bypass = 0 V) | $R_{(BP)}$ | 6.0 | 9.2 | 16 | $\text{k}\Omega$ |
| Bypass Voltage ($V_{CC} = 16\text{ V}$, Ref/Dwell = Advance = 1.0 V, EST = 0V) | $V_{(BP)}$ | - | 0.065 | 0.1 | V |
| Bypass Threshold Voltage ⁽⁸⁾ (Ref/Dwell = Advance = 1.0 V, EST = 3.0 V) Increasing Decreasing Hysteresis | $V_{TH+(BP)}$ $V_{TH-(BP)}$ $V_{HYS(BP)}$ | $V_B + 1.6$ $V_B + 0.9$ 0.65 | $V_B + 0.188$ $V_B + 0.103$ 0.86 | $V_B + 2.1$ - - | V |
| Current Sense Threshold Voltage ⁽⁹⁾ ($V_{CC} = 16\text{ V}$, Ref/Dwell = Advance = 1.0 V, EST = Bypass = 3.0 V) | $V_{TH(CS)}$ | 90 | 105 | 121 | mV |
| EST Input Resistance ($V_{CC} = 16\text{ V}$, Ref/Dwell = Advance = 1.0 V, Bypass = 3.0 V) | $R_{(EST)}$ | 7.0 | 10.3 | 18 | $\text{k}\Omega$ |
| EST Input Voltage (EST Mode) ($V_{CC} = 16\text{ V}$, Ref/Dwell = Advance = 1.0 V, Bypass = 3.0 V) | $V_{(EST)}$ | - | 0.07 | 0.1 | V |

Notes

- Advance Threshold Voltage is the positive (or negative) going voltage on Advance necessary cause the Dwell Control voltage to positive (or negative) going transition 2.0 V respectively. It is expressed as $V_{TH\pm(A)} = V_B + V_X$ where V_B is the Bias Voltage and V_X is the additional voltage necessary to attain the threshold.
- Bypass Threshold Voltage is the positive (or negative) going voltage on Bypass necessary cause the Dwell voltage to positive (or negative) going transition 1.5 V respectively. It is expressed as $V_{TH\pm(BP)} = V_B + V_X$ where V_B is the Bias Voltage and V_X is the additional voltage necessary to attain the threshold.
- Increasing voltage on Current Sense which when attained will cause Dwell to transition low to 1.5 V with a 10 mA load.

Table 2. Static Electrical Characteristics (continued)

Characteristics noted under conditions $7.0\text{ V} \leq V_{CC} \leq 18\text{ V}$, $-40^\circ\text{C} \leq T_A \leq 125^\circ\text{C}$, $\text{GND} = 0\text{ V}$ unless otherwise noted. Typical values noted reflect the approximate parameter means at $T_A = 25^\circ\text{C}$ under nominal conditions unless otherwise noted.

| Characteristic | Symbol | Min | Typ | Max | Unit |
|---|-------------------|---------------|---------------|---------------|---------------|
| EST Threshold Voltage ⁽¹⁰⁾ (Ref/Dwell = Advance = 1.0 V, Bypass = 3.0 V) | | | | | V |
| Increasing | $V_{TH+(EST)}$ | 1.65 | 1.86 | 2.0 | |
| Decreasing | $V_{TH-(EST)}$ | 0.8 | 0.89 | - | |
| Hysteresis | $V_{HYS(EST)}$ | 0.79 | 0.97 | - | |
| Ref/Dwell Current ⁽¹¹⁾ ($V_{CC} = 16\text{ V}$, Advance = 1.0 V, EST = Bypass = 0 V) | $I_{(R/D)}$ | | | | μA |
| Ref/Dwell Voltage = 1.0 V | | -12 | -1.38 | 1.0 | |
| Ref/Dwell Voltage = 20 V | | -1.0 | 0.02 | 5.0 | |
| Ref/Dwell Clamp Voltage ($V_{CC} = 16\text{ V}$, Advance = 1.0 V, EST = Bypass = 0 V) | $V_{(R/D)CL}$ | | | | V |
| $I_{R/D} = 100\mu\text{A}$ (Sourcing) | | -0.01 | -0.04 | 0.2 | |
| $I_{R/D} = 1.0\text{mA}$ (Sourcing) | | -0.62 | -0.54 | - | |
| Ref/Dwell Threshold (Bypass Mode) ⁽¹²⁾ (Advance = 1.0 V, EST = Bypass = 0 V, Reference = sinking 10 μA) | | | | | V |
| Increasing | $V_{TH+(R/D)BP}$ | $V_B + 0.09$ | $V_B + 0.106$ | $V_B + 0.116$ | |
| Decreasing | $V_{TH-(R/D)BP}$ | $V_B + 0.018$ | $V_B + 0.03$ | - | |
| Hysteresis | $V_{HYS(R/D)BP}$ | 0.055 | 0.076 | - | |
| Ref/Dwell Threshold (EST Mode) ⁽¹²⁾ (Advance = 1.0 V, EST = 0 V, Bypass = 3.0 V, Reference = sinking 10 μA) | | | | | V |
| Increasing | $V_{TH+(R/D)EST}$ | $V_B + 0.445$ | $V_B + 0.50$ | $V_B + 0.535$ | |
| Decreasing | $V_{TH-(R/D)EST}$ | $V_B + 0.038$ | $V_B + 0.062$ | - | |
| Hysteresis | $V_{HYS(R/D)EST}$ | 0.395 | 0.436 | - | |
| Ref/Dwell Threshold (No Pump) ⁽¹³⁾ (Advance = 1.0 V, EST = Bypass = 0 V, Dwell = sinking 10 mA) | | | | | V |
| Increasing | $V_{TH+(R/D)NP}$ | $V_B + 0.003$ | $V_B + 0.118$ | $V_B + 0.128$ | |
| Decreasing | $V_{TH-(R/D)NP}$ | $V_B + 0.021$ | $V_B + 0.047$ | - | |
| Hysteresis | $V_{HYS(R/D)NP}$ | $V_B + 0.013$ | $V_B + 0.072$ | - | |

Notes

- EST Threshold Voltage is the positive (or negative) going voltage on EST necessary cause the Dwell voltage to positive (or negative) going transition 1.5 V respectively. It is expressed as $V_{TH\pm(EST)}$ and is in reference to ground.
- Ref/Dwell can either source or sink current; A minus sign denotes the Ref/Dwell is sourcing current.
- Ref/Dwell Threshold Voltage (Bypass Mode) is the positive (or negative) going voltage on Ref/Dwell necessary cause the Reference voltage to positive (or negative) going transition 1.5 V respectively. It is expressed as $V_{TH\pm(RD)} = V_B + V_X$ where V_B is the Bias Voltage and V_X is the additional voltage necessary to attain the threshold.
- Ref/Dwell Threshold Voltage (No Pump) is the positive (or negative) going voltage on Ref/Dwell necessary cause the Dwell voltage to positive (or negative) going transition 1.5 V respectively. It is expressed as $V_{TH\pm(RD)} = V_B + V_X$ where V_B is the Bias Voltage and V_X is the additional voltage necessary to attain the threshold. Advance = 1.0 V providing no input assist or "No Pump" influence of Dwell signal; Reference open.

Table 2. Static Electrical Characteristics (continued)

Characteristics noted under conditions $7.0\text{ V} \leq V_{CC} \leq 18\text{ V}$, $-40^\circ\text{C} \leq T_A \leq 125^\circ\text{C}$, $\text{GND} = 0\text{ V}$ unless otherwise noted. Typical values noted reflect the approximate parameter means at $T_A = 25^\circ\text{C}$ under nominal conditions unless otherwise noted.

| Characteristic | Symbol | Min | Typ | Max | Unit |
|--|--------------------------------|---------------|---------------|---------------|------|
| Ref/Dwell Threshold (Max Pump) ⁽¹⁴⁾ ($V_{CC} = 16\text{ V}$, Advance = 3.0 V, EST = Bypass = 0 V, Dwell sinking 10 mA, Dwell Control = open) | | | | | V |
| Increasing | $V_{\text{TH}+(R/D)\text{MP}}$ | $V_B + 0.175$ | $V_B + 0.474$ | $V_B + 0.80$ | |
| Decreasing | $V_{\text{TH}-(R/D)\text{MP}}$ | $V_B + 0.115$ | $V_B + 0.425$ | $V_B + 0.735$ | |
| Hysteresis | $V_{\text{HYS}(R/D)\text{MP}}$ | $V_B + 0.025$ | $V_B + 0.048$ | - | |

OUTPUTS

| | | | | | |
|--|---------------------|------|-------|------|------------------|
| Bias Resistance to Ground Dwell = $V_{CC} = \text{Ref/Dwell} = \text{Reference} = \text{Dwell Control} = \text{open}$, Advance = 1.0 V, EST = Bypass = 0 V | $R_{(B)}$ | 0.55 | 0.68 | 0.9 | $\text{k}\Omega$ |
| Bias Voltage (Bypass Mode) Ref/Dwell = Advance = 1.0 V, EST = Bypass = 0 V | $V_{(B)\text{BP}}$ | 2.25 | 2.43 | 2.6 | V |
| Bias Voltage Regulation (Bypass Mode) Ref/Dwell = Advance = 1.0 V, EST = Bypass = 0 V | $V_{(B)\text{BP}}$ | - | 30 | 40 | mV |
| Bias Voltage (EST Mode) $V_{CC} = 16\text{ V}$, Ref/Dwell = Advance = 1.0 V, EST = 0 V, Bypass = 3.0 V | $V_{(B)\text{EST}}$ | 1.9 | 2.04 | 2.2 | V |
| Dwell Saturation Voltage $V_{CC} = 4.0\text{ V}$, $I_D = 40\text{ mA}$, Ref/Dwell = Advance = 3.0 V, EST = Bypass = 0 V $V_{CC} = 16\text{ V}$, $I_D = 160\text{ mA}$, Ref/Dwell = Advance = 3.0 V, EST = Bypass = 0 V $V_{CC} = 24\text{ V}$, $I_D = 240\text{ mA}$, Ref/Dwell = Advance = 1.0 V, EST = Bypass = 3.0 V $V_{CC} = 36\text{ V}$, $I_D = 360\text{ mA}$, Ref/Dwell = Advance = 1.0 V, EST = Bypass = 3.0 V | $V_{(D)\text{SAT}}$ | - | 0.05 | 0.1 | V |
| Dwell Reverse Clamp Voltage ⁽¹⁵⁾ | $V_{(D)\text{REV}}$ | -0.9 | -0.98 | -1.2 | V |
| Dwell Leakage Current ⁽¹⁶⁾ $V_{CC} = 16\text{ V}$, Dwell = 5.0 V, Ref/Dwell = Advance = 3.0 V, EST = Bypass = 0, Bias Voltage = Reference = open | $I_{(D)\text{KG}}$ | - | 0.044 | 50 | μA |
| Reference Low ⁽¹⁷⁾ $I_R = \text{sinking } 0.3\text{ mA}$, Ref/Dwell = Advance = 1.0 V, EST = Bypass = 0 V | $V_{(R)\text{LOW}}$ | - | 0.13 | 0.22 | V |

Notes

- Ref/Dwell Threshold Voltage (Max Pump) is the positive (or negative) going voltage on Ref/Dwell necessary cause the Dwell voltage to positive (or negative) going transition 1.5 V respectively. It is expressed as $V_{\text{TH}\pm(RD)} = V_B + V_X$ where V_B is the Bias Voltage and V_X is the additional voltage necessary to attain the threshold. Advance = 3.0 V providing maximum input assist or Max Pump" influence of Dwell signal; Reference = Dwell Control = open.
- All pins open except Pwr Gnd with Dwell sinking 200 mA.
- Limit conditions with Dwell output NPN in the OFF condition.
- Reference saturation voltage to ground with 0.3mA of current going into the Reference.

Table 2. Static Electrical Characteristics (continued)

Characteristics noted under conditions $7.0\text{ V} \leq V_{CC} \leq 18\text{ V}$, $-40^\circ\text{C} \leq T_A \leq 125^\circ\text{C}$, $\text{GND} = 0\text{ V}$ unless otherwise noted. Typical values noted reflect the approximate parameter means at $T_A = 25^\circ\text{C}$ under nominal conditions unless otherwise noted.

| Characteristic | Symbol | Min | Typ | Max | Unit |
|---|------------------|---------|--------------|----------|------|
| Reference High/Un-Clamped ⁽²⁷⁾ $V_{CC} = 4.0\text{ V}$, $I_R = \text{sourcing } 100\text{ mA}$, Ref/Dwell = 3.0 V, Advance = 1.0 V, EST = Bypass = 0 V | $V_{(R)HI/UNCL}$ | 3.2 | 3.36 | - | V |
| Reference High/Clamped ⁽²⁷⁾ $V_{CC} = 16\text{ V}$, Ref/Dwell = 3.0 V, Advance = 1.0 V, EST = Bypass = 0 V $I_R = \text{sourcing } 10\text{ }\mu\text{A}$ $I_R = \text{sourcing } 1.0\text{ mA}$ | $V_{(R)HI/CL}$ | - 12 | 5.41 15.3 | 6.0 - | V |

CONTROLS

| | | | | | |
|--|------------------|--------------|--------------|------------|---------------|
| Dwell Control Negative Clamp Voltage ⁽²⁷⁾ $V_{CC} = 16\text{ V}$, $I_{DC} = \text{sourcing } 100\text{ }\mu\text{A}$, Ref/Dwell = Advance = 1.0 V, EST = Bypass = 0 V | $V_{(DC)-CL}$ | 0.5 | 0.7 | 0.8 | V |
| Dwell Control Positive Clamp Voltage ⁽²⁷⁾ $V_{CC} = 16\text{ V}$, $I_{DC} = \text{sinking } 100\text{ }\mu\text{A}$, Ref/Dwell = 1.0 V, Advance = Open, EST = Bypass = 0 V | $V_{(DC)+CL}$ | 8.0 | 8.2 | 8.4 | V |
| Dwell Control Charge Current ⁽²⁷⁾ $V_{CC} = 16\text{ V}$, Ref/Dwell = 1.0 V, Advance = Dwell Control = 3.0 V, EST = Bypass = 0 V | $I_{(DC)CHG}$ | 30 | 47 | 58 | μA |
| Dwell Control Discharge Current ⁽²⁷⁾ $V_{CC} = 16\text{ V}$, Current Sense = 0.5 V, Ref/Dwell = Advance = 1.0 V, EST = Bypass = 0 V | $I_{(DC)DISCHG}$ | 18 | 33 | 48 | μA |
| Dwell Control Input Current ⁽²⁷⁾ $V_{CC} = 16\text{ V}$, Ref/Dwell = Advance = 1.0 V, EST = Bypass = 0 V, Dwell Control = 7.0 V | $I_{(DC)SINK}$ | - | 1.1 | 2.5 | μA |
| RPM Detect Charge Current ON ⁽²⁷⁾ $V_{CC} = 16\text{ V}$, Ref/Dwell = 3.0 V, Advance = 1.0 V, EST = Bypass = 0 V | $I_{(RPM)CHG}$ | -4.0 | 0.54 | 1.0 | mA |
| RPM Detect Current ⁽²⁷⁾ $V_{CC} = 16\text{ V}$, 1.0 V = Ref/Dwell = Advance = 3.0 V, EST = Bypass = 0 V RPM Detect = 0.5 V RPM Detect = 1.5 V | $I_{(RPM)LKG}$ | 04.0 -0.1 | 0.55 0.01 | 1.0 0.1 | μA |
| RPM Detect Clamp Voltage ⁽²⁷⁾ $V_{CC} = 16\text{ V}$, Ref/Dwell = 3.0 V, Advance = 1.0 V, EST = Bypass = 0 V, RPM Detect = sourcing 16 μA | $V_{(RPM)CL}$ | 2.4 | 2.5 | 2.7 | V |

Notes

18. Dwell Control adjusts the reference voltage of Dwell Comparator.
19. Dwell Control. sourcing 100 μA .
20. Dwell Control sinking 100 μA .
21. Dwell Control at 3.0 V; Internal Dwell Control transistor OFF.
22. Dwell Control at 3.0 V; Internal Dwell Control transistor ON.
23. Dwell Control at 7.0 V; Internal Dwell Control transistor OFF.
24. Q53 and Q54 both ON; Measured with RPM Detect voltage at 0.5 V to reflect maximum source current capability. See [Typical Applications on page 10](#)
25. Q53 and Q54 both OFF; Measured with RPM Detect voltage at 0.5 V and 1.5 V to reflect maximum leakage current. [Typical Applications on page 10](#)
26. Q53 and Q54 both ON; RPM Detect sinking 16 μA . [Typical Applications on page 10](#)

Table 2. Static Electrical Characteristics (continued)

Characteristics noted under conditions $7.0\text{ V} \leq V_{CC} \leq 18\text{ V}$, $-40^\circ\text{C} \leq T_A \leq 125^\circ\text{C}$, $\text{GND} = 0\text{ V}$ unless otherwise noted. Typical values noted reflect the approximate parameter means at $T_A = 25^\circ\text{C}$ under nominal conditions unless otherwise noted.

| Characteristic | Symbol | Min | Typ | Max | Unit |
|--|-----------------------|-----|------|-----|------|
| RPM Detect Threshold ⁽²⁷⁾ $V_{CC} = 16\text{ V}$, Ref/Dwell = Advance = 3.0 V, EST = Bypass = 0 V | $V_{\text{TH-(RPM)}}$ | 0.8 | 0.92 | 1.0 | V |
| RPM Detect Charge Current $V_{CC} = 16\text{ V}$, Ref/Dwell = 3.0 V, Advance = 1.0 V, EST = Bypass = 0 V | $I_{\text{(RPM)CHG}}$ | - | -2.0 | - | mA |

Notes

27. Decreasing Threshold; RPM Detect voltage decreased from 0.6 V until Dwell voltage transitions low to 1.5 V with 10 mA load.

PACKAGING

PACKAGE DIMENSIONS

For the most current package revision, visit www.freescale.com and perform a keyword search using the "98A" listed below.

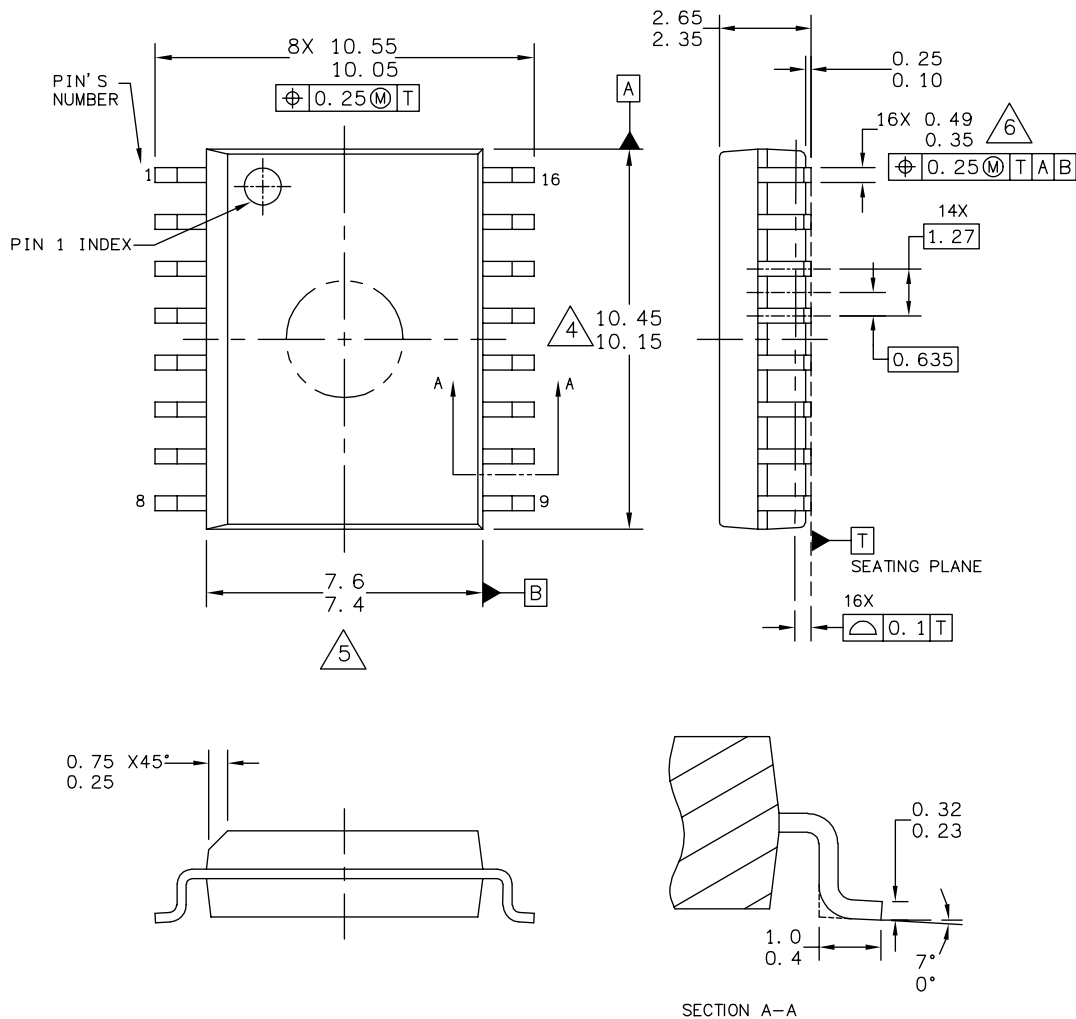

| | | |
|---|---------------------------|----------------------------|
| © FREESCALE SEMICONDUCTOR, INC. ALL RIGHTS RESERVED. | MECHANICAL OUTLINE | PRINT VERSION NOT TO SCALE |
| TITLE: 16LD SOIC W/B, 1.27 PITCH CASE-OUTLINE | DOCUMENT NO: 98ASB42567B | REV: F |
| | CASE NUMBER: 751G-04 | 02 JUN 2005 |
| | STANDARD: JEDEC MS-013AA | |

DW SUFFIX
EG SUFFIX (PB-FREE)
16-PIN
PLASTIC PACKAGE
98ASB42567B
ISSUE F

REVISION HISTORY

| REVISION | DATE | DESCRIPTION OF CHANGES |
|----------|--------|---|
| 3.0 | 3/2007 | <ul style="list-style-type: none">• Implemented Revision History page• Converted to Freescale format• Added MCZ79076EG/R2 to the Ordering Information• Removed MCCF79076 and all corresponding references. |

How to Reach Us:

Home Page:

www.freescale.com

Web Support:

<http://www.freescale.com/support>

USA/Europe or Locations Not Listed:

Freescale Semiconductor, Inc.
Technical Information Center, EL516
2100 East Elliot Road
Tempe, Arizona 85284
+1-800-521-6274 or +1-480-768-2130
www.freescale.com/support

Europe, Middle East, and Africa:

Freescale Halbleiter Deutschland GmbH
Technical Information Center
Schatzbogen 7
81829 Muenchen, Germany
+44 1296 380 456 (English)
+46 8 52200080 (English)
+49 89 92103 559 (German)
+33 1 69 35 48 48 (French)
www.freescale.com/support

Japan:

Freescale Semiconductor Japan Ltd.
Headquarters
ARCO Tower 15F
1-8-1, Shimo-Meguro, Meguro-ku,
Tokyo 153-0064
Japan
0120 191014 or +81 3 5437 9125
support.japan@freescale.com

Asia/Pacific:

Freescale Semiconductor Hong Kong Ltd.
Technical Information Center
2 Dai King Street
Tai Po Industrial Estate
Tai Po, N.T., Hong Kong
+800 2666 8080
support.asia@freescale.com

For Literature Requests Only:

Freescale Semiconductor Literature Distribution Center
P.O. Box 5405
Denver, Colorado 80217
1-800-441-2447 or 303-675-2140
Fax: 303-675-2150
LDCForFreescaleSemiconductor@hibbertgroup.com

RoHS-compliant and/or Pb-free versions of Freescale products have the functionality and electrical characteristics of their non-RoHS-compliant and/or non-Pb-free counterparts. For further information, see <http://www.freescale.com> or contact your Freescale sales representative.

For information on Freescale's Environmental Products program, go to <http://www.freescale.com/epp>.

Information in this document is provided solely to enable system and software implementers to use Freescale Semiconductor products. There are no express or implied copyright licenses granted hereunder to design or fabricate any integrated circuits or integrated circuits based on the information in this document.

Freescale Semiconductor reserves the right to make changes without further notice to any products herein. Freescale Semiconductor makes no warranty, representation or guarantee regarding the suitability of its products for any particular purpose, nor does Freescale Semiconductor assume any liability arising out of the application or use of any product or circuit, and specifically disclaims any and all liability, including without limitation consequential or incidental damages. "Typical" parameters that may be provided in Freescale Semiconductor data sheets and/or specifications can and do vary in different applications and actual performance may vary over time. All operating parameters, including "Typicals", must be validated for each customer application by customer's technical experts. Freescale Semiconductor does not convey any license under its patent rights nor the rights of others. Freescale Semiconductor products are not designed, intended, or authorized for use as components in systems intended for surgical implant into the body, or other applications intended to support or sustain life, or for any other application in which the failure of the Freescale Semiconductor product could create a situation where personal injury or death may occur. Should Buyer purchase or use Freescale Semiconductor products for any such unintended or unauthorized application, Buyer shall indemnify and hold Freescale Semiconductor and its officers, employees, subsidiaries, affiliates, and distributors harmless against all claims, costs, damages, and expenses, and reasonable attorney fees arising out of, directly or indirectly, any claim of personal injury or death associated with such unintended or unauthorized use, even if such claim alleges that Freescale Semiconductor was negligent regarding the design or manufacture of the part.

Freescale™ and the Freescale logo are trademarks of Freescale Semiconductor, Inc. All other product or service names are the property of their respective owners.

© Freescale Semiconductor, Inc., 2007. All rights reserved.

Looking for pricing, stock, or lifecycle information?

Click below to explore more details on WIN SOURCE:

 [View MCZ79076EG on WIN SOURCE](#)

 [NXP / Nexperia Information](#)

Optimize Your Supply Chain with WIN SOURCE Solutions

-  Global Sourcing Solution
-  Obsolete Management
-  Cost Control Management
-  Shortage Management
-  Alternative Solution
-  Excess Inventory Management