



**THE DATASHEET OF
MC33SB0400ES**



ABS motorcycle braking chip

The SB0400 is an antilock brake controller designed for use in harsh motorcycle environments.

It has four high-current low-side drivers for use with solenoid valves, two configurable wheel speed sense inputs capable of handling active sensors, and high-side gate drivers for controlling two external N-channel MOSFETs for use with a pump motor and master relay for solenoid coils. Along with this main functionality, the SB0400 also has a warning lamp driver and a K-line transceiver. The SB0400 boosts an internal charge pump, allowing the high-side drivers to use inexpensive N-channel MOSFETs. The digital I/O pins can be configured for both 5.0 V and 3.3 V levels for easy connection to any microprocessor. The SB0400 uses standard SPI protocol for communication.

The SB0400 is a solution for ABS braking application, and powered by SMARTMOS technology.

Features

- Four PWMed valves driver
- High-side pre-driver for valves protection
- Two wheel speed sensor interfaces (active)
- Dual vehicle speed outputs
- Pump motor pre-driver
- 16-bit SPI interface with watchdog
- K-line interface
- Warning lamp driver
- Die temperature warning
- Supervision

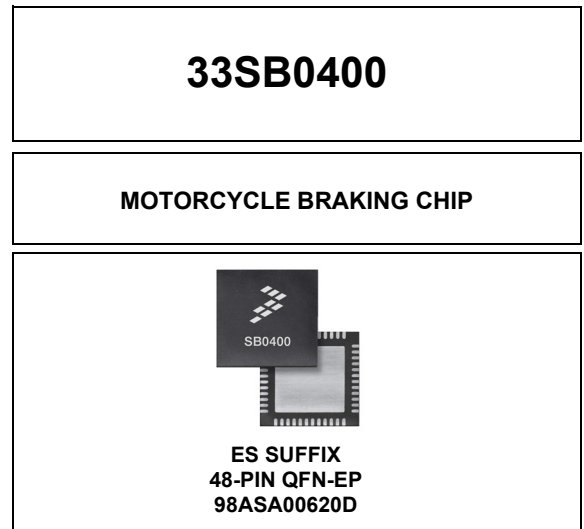

Applications

- Motorcycle braking on two wheels

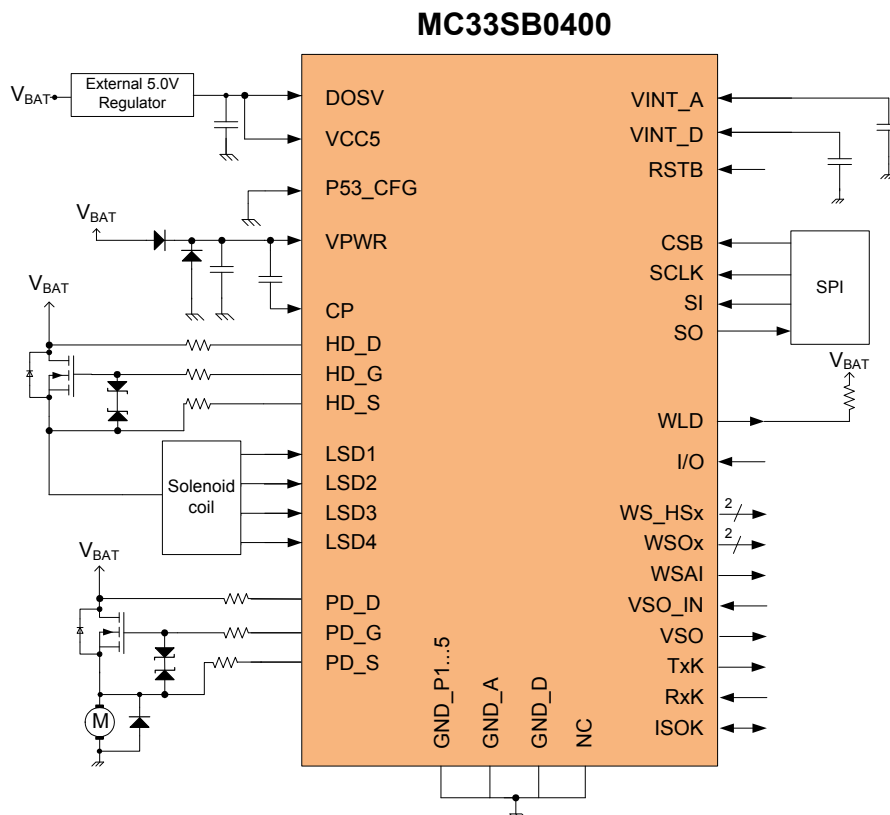

Figure 1. SB0400 simplified application diagram

* This document contains certain information on a new product. Specifications and information herein are subject to change without notice.

Table 1. Orderable part variations

| Part number | Notes | Temperature (T _A) | Package | Description |
|--------------|-------|-------------------------------|--|---|
| MC33SB0400ES | (1) | -40 °C to 125 °C | 7 x 7 x 0.9, 48-Pin QFN Exposed Pad, with 0.5 mm pitch, and a 5.6 x 5.6 exposed pad | <ul style="list-style-type: none"> • Four PWMed valves control • Safe switch control • Two wheel speed sensors • Pump motor control • ISO K-line interface • One warning lamp |

Notes

1. To order parts in Tape & Reel, add the R2 suffix to the part number.

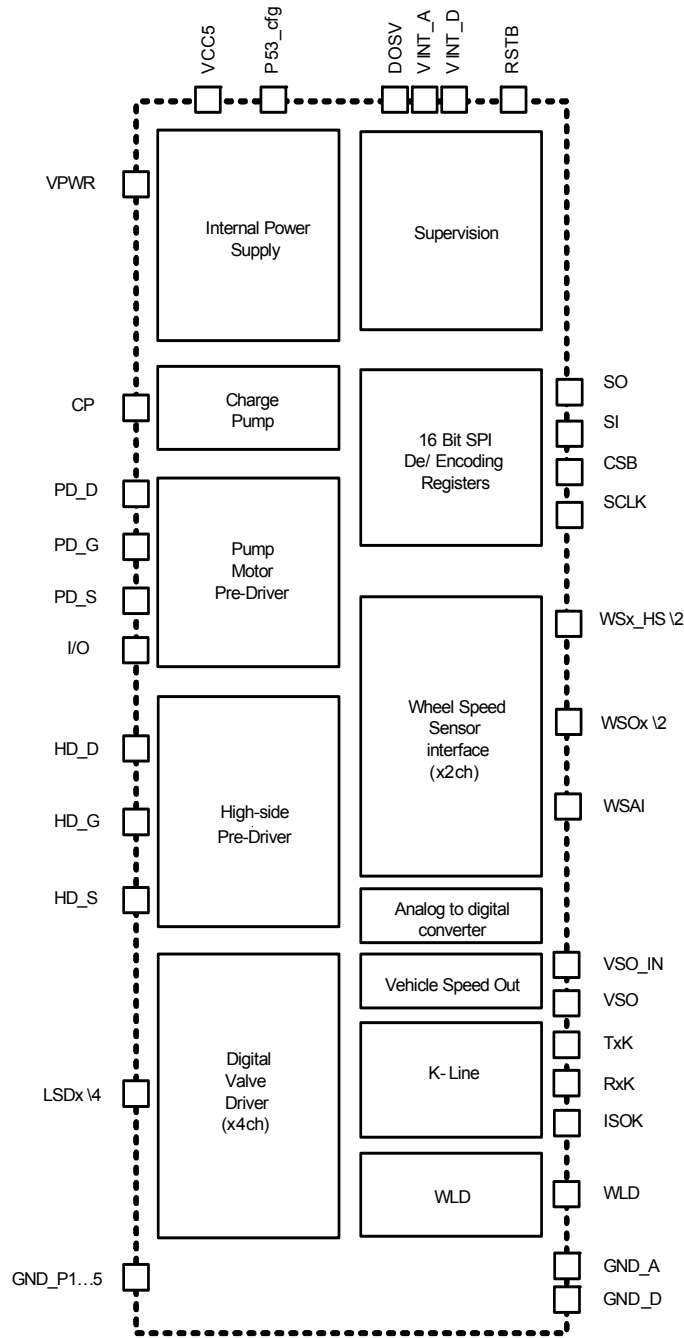

Figure 2. SB0400 simplified block diagram

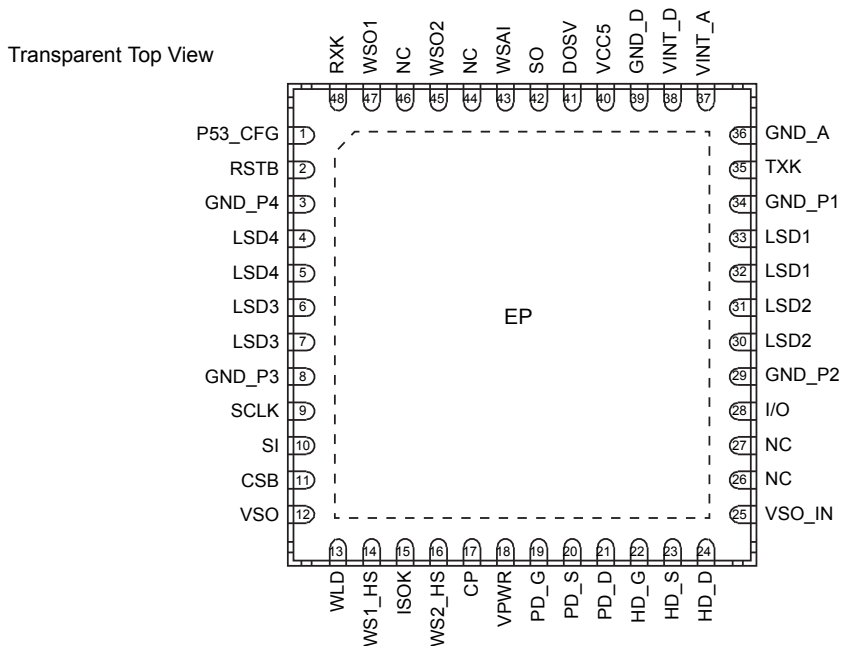

Figure 3. SB0400 48-pin QFN-EP pinout diagram

Table 2. SB0400 pin definitions

| Pin number | Pin name | Pin Function |
|------------|----------|--|
| 1 | P53_CFG | Supply |
| 2 | RSTB | Reset |
| 3 | GND_P4 | Supply |
| 4, 5 | LSD4 | Low-side Driver for Valves |
| 6, 7 | LSD3 | Low-side Driver for Valves |
| 8 | GND_P3 | Supply |
| 9 | SCLK | SPI |
| 10 | SI | SPI |
| 11 | CSB | SPI |
| 12 | VSO | Vehicle Speed Output |
| 13 | WLD | Warning Lamp Driver |
| 14 | WS1_HS | Wheel Speed Sensor Interface |
| 15 | ISOK | K-LINE |
| 16 | WS2_HS | Wheel Speed Sensor Interface |
| 17 | CP | Charge Pump |
| 18 | VPWR | Supply |
| 19 | PD_G | Motor Pump Driver |
| 20 | PD_S | Motor Pump Driver |
| 21 | PD_D | Motor Pump Driver |
| 22 | HD_G | High-side Driver for Valve's Fail Safe FET |
| 23 | HD_S | High-side Driver for Valve's Fail Safe FET |
| 24 | HD_D | High-side Driver for Valve's Fail Safe FET |
| 25 | VSO_IN | Digital Input of VSO |

| Pin Number | Pin Name | Pin Function |
|-------------|----------|------------------------------|
| 25 | VSO_IN | Digital Input of VSO |
| 28 | I/O | General I/O |
| 29 | GND_P2 | Supply |
| 30, 31 | LSD2 | Low-side Driver for Valves |
| 32, 33 | LSD1 | Low-side Driver for Valves |
| 34 | GND_P1 | Supply |
| 35 | TXK | K-LINE |
| 36 | GND_A | Supply |
| 37 | VINT_A | Internal Function |
| 38 | VINT_D | Internal Function |
| 39 | GND_D | Supply |
| 40 | VCC5 | Supply |
| 41 | DOSV | Supply |
| 42 | SO | SPI |
| 43 | WSAI | Wheel Speed Sensor Interface |
| 45 | WSO2 | Wheel Speed Sensor Interface |
| 47 | WSO1 | Wheel Speed Sensor Interface |
| 48 | RXK | K-LINE |
| 26, 27 | NC | Not connected |
| 44, 46 | NC | Not connected |
| Exposed pad | GND_P5 | Supply |

Table 3. Key parameters

Characteristics noted under conditions $6.0\text{ V} \leq V_{PWR} \leq 20\text{ V}$, $4.75\text{ V} \leq V_{CC5} \leq 5.25\text{ V}$, $3.13\text{ V} \leq V_{DOSV} \leq 5.25\text{ V}$, $-40\text{ }^\circ\text{C} \leq T_J \leq 150\text{ }^\circ\text{C}$, $GND = 0\text{ V}$, unless otherwise noted.

| Symbol | Characteristic | Typ. | Unit | Notes |
|--------|----------------|------|------|-------|
|--------|----------------|------|------|-------|

VPWR current consumptions

| | | | | |
|-------------|--|-----|---------------|--|
| I_{QVPWR} | Sleep Mode Measured at $V_{PWR} = 14\text{ V}$ | 3.0 | μA | |
| I_{VPWR} | Operating Mode | 10 | mA | |

VCC5 current consumptions

| | | | | |
|------------|----------------|----|----|--|
| I_{VCC5} | Operating Mode | 10 | mA | |
|------------|----------------|----|----|--|

Timings

| | | | | |
|---|---|--|-----|--|
| LF_PWM | Output PWM frequency <ul style="list-style-type: none"> • LF_PWM_14 = 111 • LF_PWM_14 = 110 • LF_PWM_14 = 101 • LF_PWM_14 = 100 • LF_PWM_14 = 000 (default) • LF_PWM_14 = 011 • LF_PWM_14 = 001 • LF_PWM_14 = 010 | 3.0 3.2 3.4 3.6 3.9 4.2 4.5 5.0 | kHz | |
| 0000 0000 0000 0001 ... 1111 1110 1111 1111 | PWM Duty cycle Programming (8bits) | OFF 0.39 ... 99.61 ON | % | |

| Revision | Date | Description of changes |
|----------|--------|---------------------------------|
| 2.0 | 8/2016 | • Added revision history table. |



How to Reach Us:

Home Page:

[NXP.com](http://www.nxp.com)

Web Support:

<http://www.nxp.com/support>

Information in this document is provided solely to enable system and software implementers to use NXP products. There are no expressed or implied copyright licenses granted hereunder to design or fabricate any integrated circuits based on the information in this document. NXP reserves the right to make changes without further notice to any products herein.

NXP makes no warranty, representation, or guarantee regarding the suitability of its products for any particular purpose, nor does NXP assume any liability arising out of the application or use of any product or circuit, and specifically disclaims any and all liability, including without limitation, consequential or incidental damages. "Typical" parameters that may be provided in NXP data sheets and/or specifications can and do vary in different applications, and actual performance may vary over time. All operating parameters, including "typicals," must be validated for each customer application by the customer's technical experts. NXP does not convey any license under its patent rights nor the rights of others. NXP sells products pursuant to standard terms and conditions of sale, which can be found at the following address:

<http://www.nxp.com/terms-of-use.html>.

NXP, the NXP logo, Freescale, the Freescale logo, SafeAssure, the SafeAssure logo, and SMARTMOS are trademarks of NXP B.V. All other product or service names are the property of their respective owners. All rights reserved.

© 2016 NXP B.V.

Document Number: MC33SB0400SM

Rev. 2.0

8/2016



Looking for pricing, stock, or lifecycle information?

Click below to explore more details on WIN SOURCE:

 [View MC33SB0400ES](#) on WIN SOURCE

 [NXP / Nexperia](#) Information

Optimize Your Supply Chain with WIN SOURCE Solutions

-  Global Sourcing Solution
-  Obsolete Management
-  Cost Control Management
-  Shortage Management
-  Alternative Solution
-  Excess Inventory Management