



**THE DATASHEET OF  
MAX14866UTM+T**



## General Description

The MAX14866 is a 16-channel, high-voltage (HV), analog SPST switch primarily intended for HV multiplexing in ultrasound applications.

The MAX14866 operates from one only low-voltage supply (+5V) and does not require dedicated HV supplies, resulting in cost-saving and system simplification. Moreover, for in-probe applications, HV supplies do not need to be associated with the MAX14866 in the probe/transducer head, resulting in greater safety and easier compliance with safety regulations.

The MAX14866 features best-in-class performance in terms of bandwidth (up to 50MHz), charge injection (<100pC), and linear transmit input range (up to 210V<sub>PKPK</sub>). The low-signal switch  $R_{DS(ON)}$  is typically about 7 $\Omega$  around 0V and remains flat in the entire input range ensuring extremely good linearity.

The latchup-free SOI (Silicon-on-Insulator) technology and the wide analog range results in extremely high robustness during undershoots and overshoots that occur in ultrasound systems due to the resonant nature of the load.

The status of the switches can be individually controlled through a high-speed SPI interface (up to 30MHz). Daisy-chain architecture is supported.

Alternatively, switches can also be controlled with global control signal (SET and CLR) for bank selections or relay replacement applications.

The MAX14866 is offered in two different packages: wafer-level packages (WLPs) and TQFNs. The 110-bump WLP size is only 5.53 x 5.47mm, resulting in less than 1.9mm<sup>2</sup>/channel footprint and allowing for very high levels of integration, which is especially beneficial for in-probe applications.

The size of the TQFN package is an industry standard 48-pin, 7mm x 7mm package.

## Applications

- Medical Ultrasound Imaging
- Relays replacements
- NDT
- Printers

## Benefits and Features

- Flexibility and Ease-of-Design
  - HV Switches Operate From +5V Supply Only—Eliminating Dedicated High-Voltage Supplies Eases Probe Compliance To Industry Safety Standards
  - SOI Technology—Latchup Free
  - Large Analog Input range (up to 210V<sub>PKPK</sub>)
  - 16 Independent SPST Ensure Flexibility Supporting All Possible MUX Combinations
  - Switches Can Be Controlled Either Individually or Globally (Bank Selection)
  - 30MHz SPI Interface for Individually Programming the Status of the Switches
  - SET and CLR CMOS for global control of the switches (Bank Selection or Relay Replacements Applications)
  - Extended Digital Logic Input Range From 1.8V to 5V
- High Level Of Integration and Density for Space-Saving Applications
  - 16 Channels Linear SPST switches
  - < 1.9mm<sup>2</sup>/channel footprint (WLP)
- High Performance:
  - Low  $R_{ON}$  (7 $\Omega$  typ) Ensures Low Insertion Loss
  - $R_{ON}$  Flatness in the Entire Input Range Ensures Excellent Performances In Harmonic Imaging
  - Low Charge Injection <100pC.
  - Wide Bandwidth of Operation (Up to 50MHz)
  - Low On Input Capacitance (33pF)  
Low Off Input Capacitance (7.7pF)
  - Excellent Off Isolation (-75dB at 5MHz)  
Excellent Crosstalk Performances (-62dB at 5MHz)

Ordering Information appears at end of data sheet.

**Absolute Maximum Ratings**

V <sub>CC</sub> to GND .....	-0.3V to 5.6V	TQFN Continuous Power Dissipation (Single Layer Board, T <sub>A</sub> = +70°C, derate 27.8mW/°C above +70°C.).....	0mW to 2222mW
V <sub>DD</sub> to GND .....	-0.3V to 5.6V	TQFN Continuous Power Dissipation (Multilayer Board, T <sub>A</sub> = +70°C, derate 40 mW/°C above +70°C.).....	0mW to 3200mW
COM <sub>x</sub> to GND, x = 0..15.....	-110V to +110V	WLP Continuous Power Dissipation (Multilayer Board, T <sub>A</sub> = +70°C, derate 37mW/°C above +70°C.) .....	0mW to 2960mW
NO <sub>x</sub> to GND, x = 0..15.....	-110V to +110V	Operating Temperature Range .....	0°C to 85°C
COM <sub>x</sub> to NO <sub>x</sub> , x = 0..15.....	-110V to +110V	Junction Temperature .....	+150°C
SDIN to GND .....	-0.3V to 5.6V	Storage Temperature Range .....	-65°C to +150°C
SDO <sub>UT</sub> to GND .....	-0.3V to V <sub>DD</sub> + 0.3V	Soldering Temperature (reflow)	
LE to GND .....	-0.3V to 5.6V		
CLK to GND .....	-0.3V to 5.6V		
CLR to GND .....	-0.3V to 5.6V		
SET to GND .....	-0.3V to 5.6V		

**Package Thermal Characteristics (Note 1)**

110-Bump WLP	Junction-to-Ambient Thermal Resistance (θ <sub>JA</sub> ) .....	26.93°C/W	48-Pin TQFN	Junction-to-Ambient Thermal Resistance (θ <sub>JA</sub> ) .....	25°C/W
	Junction-to-Case Thermal Resistance (θ <sub>JC</sub> ).....	N/A		Junction-to-Case Thermal Resistance (θ <sub>JC</sub> ).....	1°C/W

**Note 1:** Package thermal resistances were obtained using the method described in JEDEC specification JESD51-7, using a four-layer board. For detailed information on package thermal considerations, refer to [www.maximintegrated.com/thermal-tutorial](http://www.maximintegrated.com/thermal-tutorial).

*Stresses beyond those listed under "Absolute Maximum Ratings" may cause permanent damage to the device. These are stress ratings only, and functional operation of the device at these or any other conditions beyond those indicated in the operational sections of the specifications is not implied. Exposure to absolute maximum rating conditions for extended periods may affect device reliability.*

**Electrical Characteristics**

(V<sub>CC</sub> = 5V ±5%, V<sub>DD</sub> = 1.7V to 5.5V. Typical values are V<sub>DD</sub> = +2.5V, V<sub>CC</sub> = 5V, T<sub>A</sub> = +25°C. Limits are 100% tested at T<sub>A</sub> = +85°C and are guaranteed by design in the entire temperature range )

PARAMETER	SYMBOL	CONDITIONS	MIN	TYP	MAX	UNITS
<b>POWER SUPPLIES</b>						
V <sub>DD</sub> Logic Supply Voltage	V <sub>DD</sub>		1.7		5.5	V
V <sub>DD</sub> Static Current	I <sub>D</sub> DS			1	5	µA
V <sub>DD</sub> Dynamic Current	I <sub>DD</sub>	V <sub>DD</sub> = +5V, f <sub>CLK</sub> = 5MHz, f <sub>DIN</sub> = 2.5MHz, C <sub>DO</sub> UT = 15pF		300		µA
V <sub>CC</sub> Supply Static Current	I <sub>CC</sub> S	All switches remain on or off, COM <sub>_</sub> = NO <sub>_</sub> = GND		240	425	µA
V <sub>CC</sub> Supply Dynamic Current	I <sub>CC</sub>	All Channel Switching, f = 50kHz		5.2	8.5	mA
V <sub>CC</sub> Supply Voltage Range	V <sub>CC</sub>		4.75	5	5.25	V
<b>LOGIC LEVELS</b>						
Logic-Input Low Voltage	V <sub>IL</sub>			0.33 x V <sub>DD</sub>		V
Logic-Input High Voltage	V <sub>IH</sub>		0.66 x V <sub>DD</sub>			V
Logic-Output Low Voltage	V <sub>OL</sub>	I <sub>SINK</sub> = 1mA			0.2	V
Logic-Output High Voltage	V <sub>OH</sub>	I <sub>SOURCE</sub> = 1mA	V <sub>DD</sub> -0.2			V
Logic-Input Capacitance	C <sub>IN</sub>			5		pF

**Electrical Characteristics (continued)**

( $V_{CC} = 5V \pm 5\%$ ,  $V_{DD} = 1.7V$  to  $5.5V$ . Typical values are  $V_{DD} = +2.5V$ ,  $V_{CC} = 5V$ ,  $T_A = +25^\circ C$ . Limits are 100% tested at  $T_A = +85^\circ C$  and are guaranteed by design in the entire temperature range )

PARAMETER	SYMBOL	CONDITIONS	MIN	TYP	MAX	UNITS
Logic-Input Leakage	$I_{IN}$	CLK, DIN pins	-1		+1	$\mu A$
LEB Pullup Resistor	$R_{PU}$		70	100		$K\Omega$
CLR, SET Pulldown Resistor	$R_{PDW}$		70	100		$K\Omega$
<b>SWITCH CHARACTERISTICS</b>						
Analog Dynamic Signal Range	$V_{SW\_}$	AC operation only, $f > 500kHz$	-105		+105	V
Small Signal On-Resistance	$R_{ONS}$	$V(NO) = 0V$ , $I(COM) = 5mA$		7	13	$\Omega$
Small Signal On-Resistance Matching	DRONS	3 std, $VNO\_ = 0V$ , $ICOM\_ = 5mA$		3		%
Switch Symmetry	Symm	AC measured, $100\Omega$ Resistive load NO and GND. Transmit bipolar low frequency pulse $\pm 80V$ , $f = 0.5MHz$ Compare positive and negative output level on NO Symmetry = $[V_{OP} - V_{ON}] / [0.5 \times (V_{OP} + V_{ON})]$		$\pm 1$		%
Analog Switch Peak Current	$I_{PEAK}$	$V(NO) = GND$ , $V(COM)$ HV pulse 100ns duration		2.7		A
COM to GND Leakage Current Switch OFF	$I_{COMOFF}$	$V(COM) = \pm 100mV$	-1		+1	$\mu A$
COM to GND Equivalent Resistor. Switch ON	$R_{COMON}$	$V(COM) = 100mV$	60	82	104	$K\Omega$
NO to GND Equivalent Resistor. Switch OFF	$R_{NOOFF}$	$V(NO) = 100mV$	35	52	65	$K\Omega$
NO to GND Equivalent Resistor Switch ON	$R_{NOON}$	$V(NO) = 100mV$	60	82	104	$K\Omega$
Switch-Off DC Offset COM Pin	$V_{OFF1}$	Ref. Test Circuit $R = 100K\Omega$	-5		+6	mV
Switch-Off DC Offset NO Pin	$V_{OFF2}$	Ref. Test Circuit $R = 100K\Omega$	-5		+6	mV
Switch-On DC Offset	$V_{OFF3}$	Ref. Test Circuit $R = 100K\Omega$	-5		+9	mV
<b>SWITCH DYNAMIC CHARACTERISTICS</b>						
Turn-On Time	$t_{ON}$	Ref. Test Circuit. $VCOM\_ = +1V$ , $R_L = 50\Omega$ , from switch ON digital command to 90% of the transition completed			4	$\mu s$
Turn-Off Time	$t_{OFF}$	Ref. Test Circuit $VCOM\_ = +1V$ , $R_L = 50\Omega$ from switch OFF digital command to 90% of the transition completed			4	$\mu s$
Off-Isolation in Transmission (TX)	$V_{ISOTX}$	Ref. Test Circuit		-75		dB

## Electrical Characteristics (continued)

( $V_{CC} = 5V \pm 5\%$ ,  $V_{DD} = 1.7V$  to  $5.5V$ . Typical values are  $V_{DD} = +2.5V$ ,  $V_{CC} = 5V$ ,  $T_A = +25^\circ C$ . Limits are 100% tested at  $T_A = +85^\circ C$  and are guaranteed by design in the entire temperature range )

PARAMETER	SYMBOL	CONDITIONS	MIN	TYP	MAX	UNITS
Off-Isolation in Reception (RX)	$V_{ISORX}$	Ref. Test Circuit. $Z_L = 50\Omega$		-80		dB
		Ref. Test Circuit. $Z_L = 1k\Omega // 15pF$		-60		
Crosstalk	$V_{CT}$	Ref Test Circuit. RX and TX with switches open or closed		-62		dB
SW_ Off-Capacitance Small-Signal - NO Pin	$C_{SW\_OFF}$	$f = 5MHz$ , $100mV_{PK}$ on NO pin		7.7		pF
SW_ On-Capacitance Small-Signal	$C_{SW\_ON}$	$f = 5MHz$ , $100mV_{PK}$		33		pF
SW_ Off-Capacitance Small-Signal - COM Pin	$C_{SW\_OFF}$	$f = 5MHz$ , $100mV_{PK}$ on COM pin		11		pF
SW_ Off-Capacitance Large-Signal - COM Pin	$C_{SW\_OFF}$	$f = 5MHz$ , $100V_{PK}$ on COM pin		11		pF
SW_ On-Capacitance Large-Signal	$C_{SW\_ON}$	$f = 5MHz$ , $100V_{PK}$		16		pF
Charge Injection	QCH	Ref. Test Circuit		<100		pC
Output Voltage Spike	$V_{SPK}$	Ref. Test Circuit		65		mVpkpk
Large-signal Analog Bandwidth (-3dB)	$f_{BW\_L}$	$C_{LOAD} = 200pF$ , 60V amplitude sinusoidal burst, 1% duty cycle		>50		MHz
Small-signal Analog Bandwidth (-3dB)	$f_{BW\_S}$	$C_{LOAD} = 200pF$ , 100mV amplitude sinusoidal signal		80		MHz
<b>TIMING CHARACTERISTICS</b>						
2nd Harmonic Distortion HV	THD2	$f_{OUT} = 5MHz$ , Transmit amplitude $200V_{PKPK}$ square wave (20 cycles), NO Load: $100\Omega // 100pF$		-45		dBc
Pulse Cancellation 1 Fundamental	PC1	$f_{OUT\_} = 1MHz - 5MHz$ , Transmit amplitude $200V_{PKPK}$ , 2 cycles. Strength ratio of the strongest spurious signal of the sum function in the $f_0 \pm f_0/2$ bandwidth to the fundamental signal. NO Load: $100\Omega // 100pF$		-40		dBc
Pulse Cancellation 2 Second Harmonic	PC2	$f_{OUT\_} = 1MHz - 5MHz$ , Transmit Amplitude $200V_{PKPK}$ , 2 cycles. Strength ratio of the strongest spurious signal of the sum function in the $2 \times f_0 \pm f_0/2$ bandwidth to the fundamental signal. NO Load: $100\Omega // 100pF$		-40		dBc

**Electrical Characteristics (continued)**

( $V_{CC} = 5V \pm 5\%$ ,  $V_{DD} = 1.7V$  to  $5.5V$ . Typical values are  $V_{DD} = +2.5V$ ,  $V_{CC} = 5V$ ,  $T_A = +25^\circ C$ . Limits are 100% tested at  $T_A = +85^\circ C$  and are guaranteed by design in the entire temperature range )

PARAMETER	SYMBOL	CONDITIONS	MIN	TYP	MAX	UNITS
<b>TIMING CHARACTERISTICS/SPI TIMINGS</b>						
CLK Frequency	$f_{CLK}$				30	MHz
DIN to CLK Setup Time	$t_{DS}$		3			ns
DIN to CLK Hold Time	$t_{DH}$		3			ns
CLK to $\overline{LE}$ Setup Time	$t_{CS}$		3			ns
$\overline{LE}$ Low Pulse Width	$t_{WL}$		5			ns
CLR High Pulse Width	$t_{WC}$		115			ns
SET High Pulse Width	$t_{WS}$		115			ns
CLK Rise and Fall Times	$t_R, t_F$				50	ns
CLK to DOUT Delay	$t_{DO}$	$V_{DD}$ from 2.5V - 5% to 5V + 5%, CDOUT = 15pF	5		20	ns
		$V_{DD} = +1.8V \pm 5\%$ , CDOUT = 15pF	5		30	

Typical Operating Characteristics

$V_{DD} = 3V$ ,  $V_{CC} = 5V$ ,  $T_A = 25^\circ C$ , unless otherwise noted.

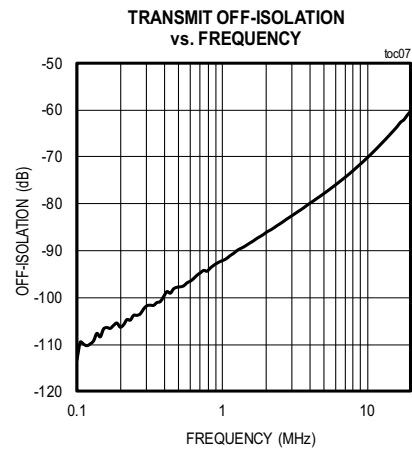
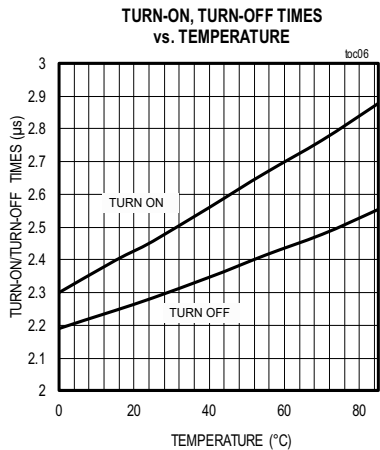
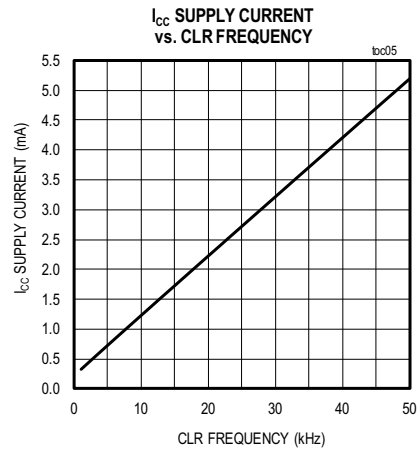
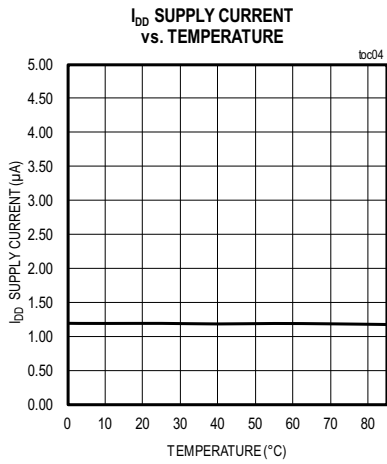
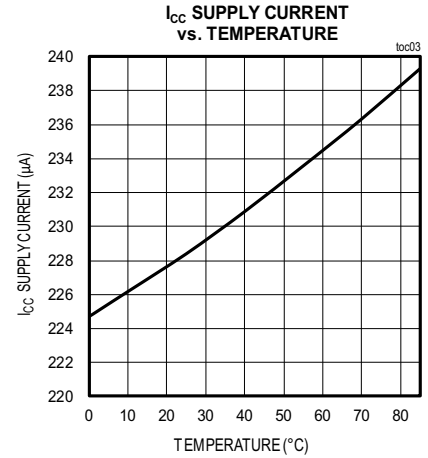
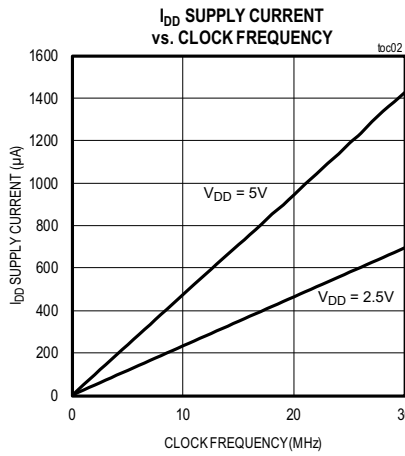
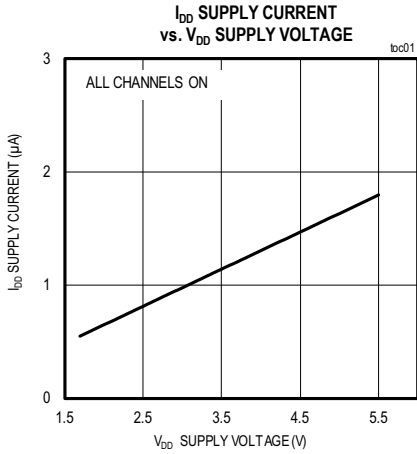

Typical Operating Characteristics (continued)

V<sub>DD</sub> = 3V, V<sub>CC</sub> = 5V, T<sub>A</sub> = 25°C, unless otherwise noted.

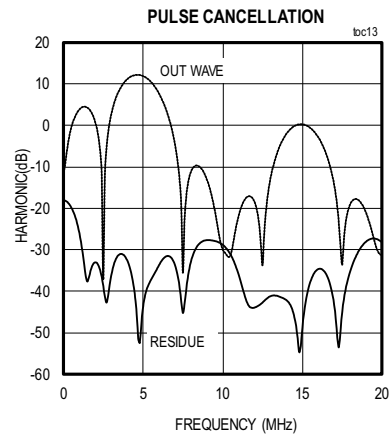
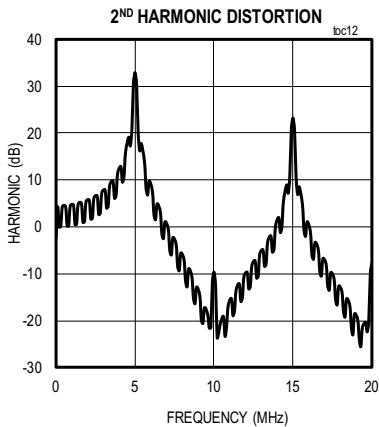
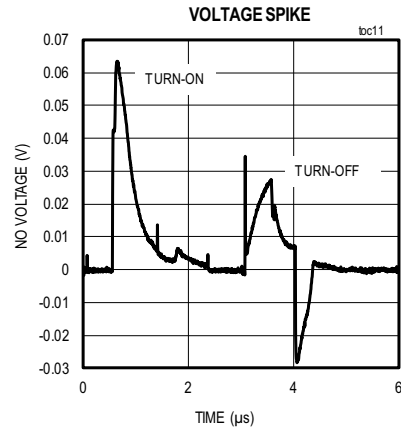
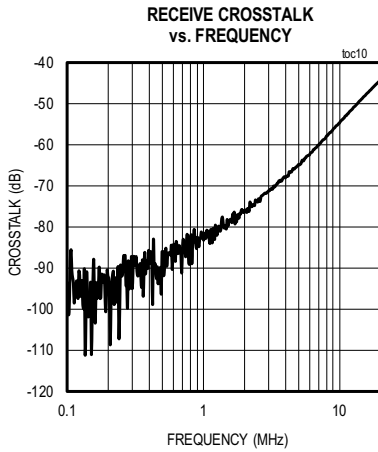
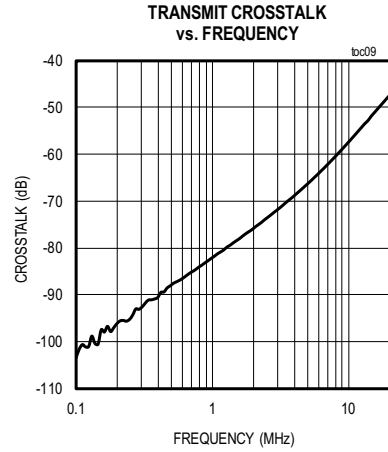
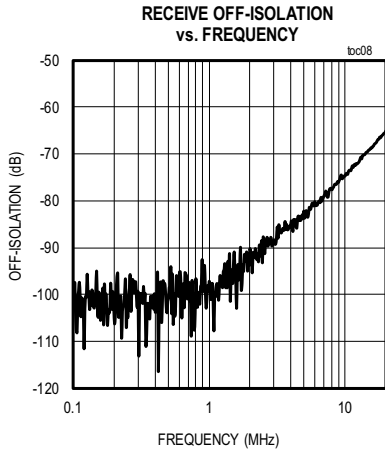

Pin Configurations

TOP VIEW

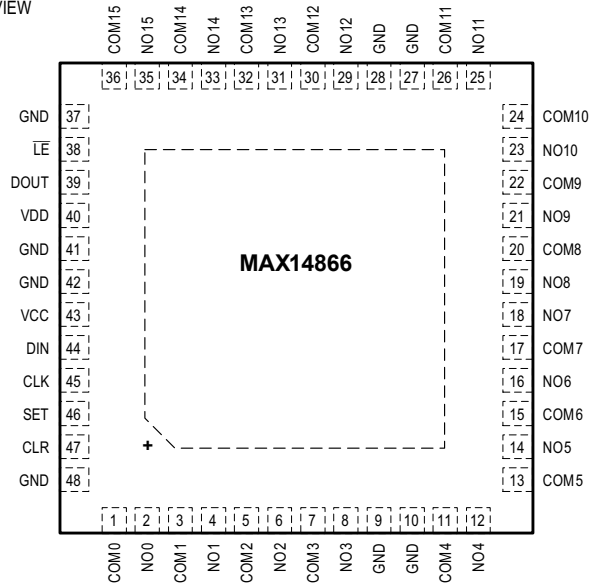

TQFN  
(7mm x 7mm)

TOP VIEW  
(BUMP SIDE DOWN)

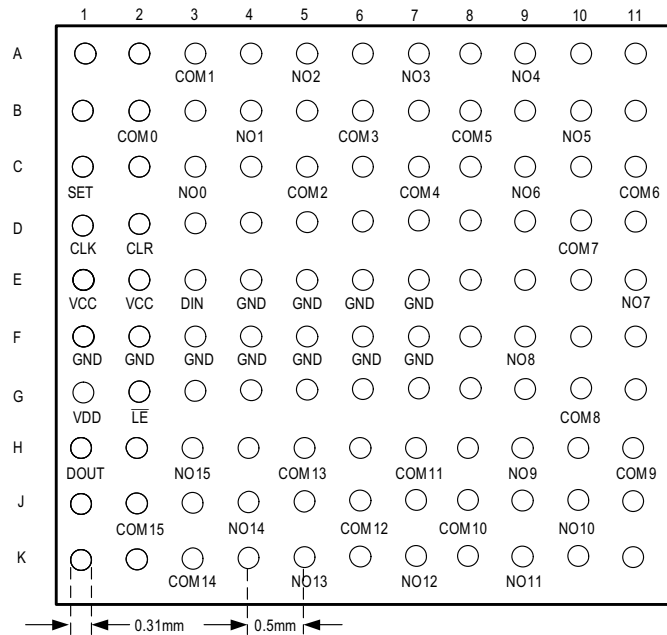

UNNAMED PINS ARE INTERNALLY NOT CONNECTED

WLP

## Pin Description

PIN		NAME	FUNCTION
MAX14866 WLP	MAX14866 TQFN		
B2	1	COM0	Analog Switch 0 - Terminal
C3	2	NO0	Analog Switch 0 - Terminal
A3	3	COM1	Analog Switch 1 - Terminal
B4	4	NO1	Analog Switch 1 - Terminal
C5	5	COM2	Analog Switch 2 - Terminal
A5	6	NO2	Analog Switch 2 - Terminal
B6	7	COM3	Analog Switch 3 - Terminal
A7	8	NO3	Analog Switch 3 - Terminal
E4–E7	9	GND	Ground
F1–F7	10	GND	Ground
C7	11	COM4	Analog Switch 4 - Terminal
A9	12	NO4	Analog Switch 4 - Terminal
B8	13	COM5	Analog Switch 5 - Terminal
B10	14	NO5	Analog Switch 5 - Terminal
C11	15	COM6	Analog Switch 6 - Terminal
C9	16	NO6	Analog Switch 6 - Terminal
D10	17	COM7	Analog Switch 7 - Terminal
E11	18	NO7	Analog Switch 7 - Terminal
F9	19	NO8	Analog Switch 8 - Terminal
G10	20	COM8	Analog Switch 8 - Terminal
H9	21	NO9	Analog Switch 9 - Terminal
H11	22	COM9	Analog Switch 9 - Terminal
J10	23	NO10	Analog Switch 10 - Terminal
J8	24	COM10	Analog Switch 10 - Terminal
K9	25	NO11	Analog Switch 11 - Terminal
H7	26	COM11	Analog Switch 11 - Terminal
	27	GND	Ground
	28	GND	Ground
K7	29	NO12	Analog Switch 12 - Terminal
J6	30	COM12	Analog Switch 12 - Terminal
K5	31	NO13	Analog Switch 13 - Terminal
H5	32	COM13	Analog Switch 13 - Terminal
J4	33	NO14	Analog Switch 14 - Terminal

## Pin Description (continued)

PIN		NAME	FUNCTION
MAX14866 WLP	MAX14866 TQFN		
K3	34	COM14	Analog Switch 14 - Terminal
H3	35	NO15	Analog Switch 15 - Terminal
J2	36	COM15	Analog Switch 15 - Terminal
	37	GND	Ground
G2	38	$\overline{LE}$	CMOS Digital Logic Input. Active-Low Latch Enable Input
H1	39	DOUT	CMOS Digital Logic Output - SPI Data Output
G1	40	VDD	Positive LV supply input for digital I/O (from 1.7V to 5.5V). Bypass VDD to GND with a 0.1 $\mu$ F or greater ceramic capacitor
	41	GND	Ground
	42	GND	Ground
E1, E2	43	VCC	Positive LV Supply Input (+5V). Bypass VCC to GND with a 0.1 $\mu$ F or greater ceramic capacitor
E3	44	DIN	CMOS Digital Logic Input - SPI Data Input
D1	45	CLK	CMOS Digital Logic Input - SPI Clock Input
C1	46	SET	CMOS Digital Logic Input - Asynchronous Set Input
D2	47	CLR	CMOS Digital Logic Input - Asynchronous Clear Input
	48	GND	Ground
—	EP		Exposed PAD (Thermal PAD). Connet EP to GND
A1, A2, A4, A6, A8, A10, A11, B1, B3, B5, B7, B9, B11, C2, C4, C6, C8, C10, D3-D9, D11, E8-E10, F8, F10, F11, G3-G9, G11, H2, H4, H6, H8, H10, J1, J3, J5, J7, J9, J11, K1, K2, K4, K6, K8, K10, K11	—	N.C.	Not internally connected

Functional (or Block) Diagram

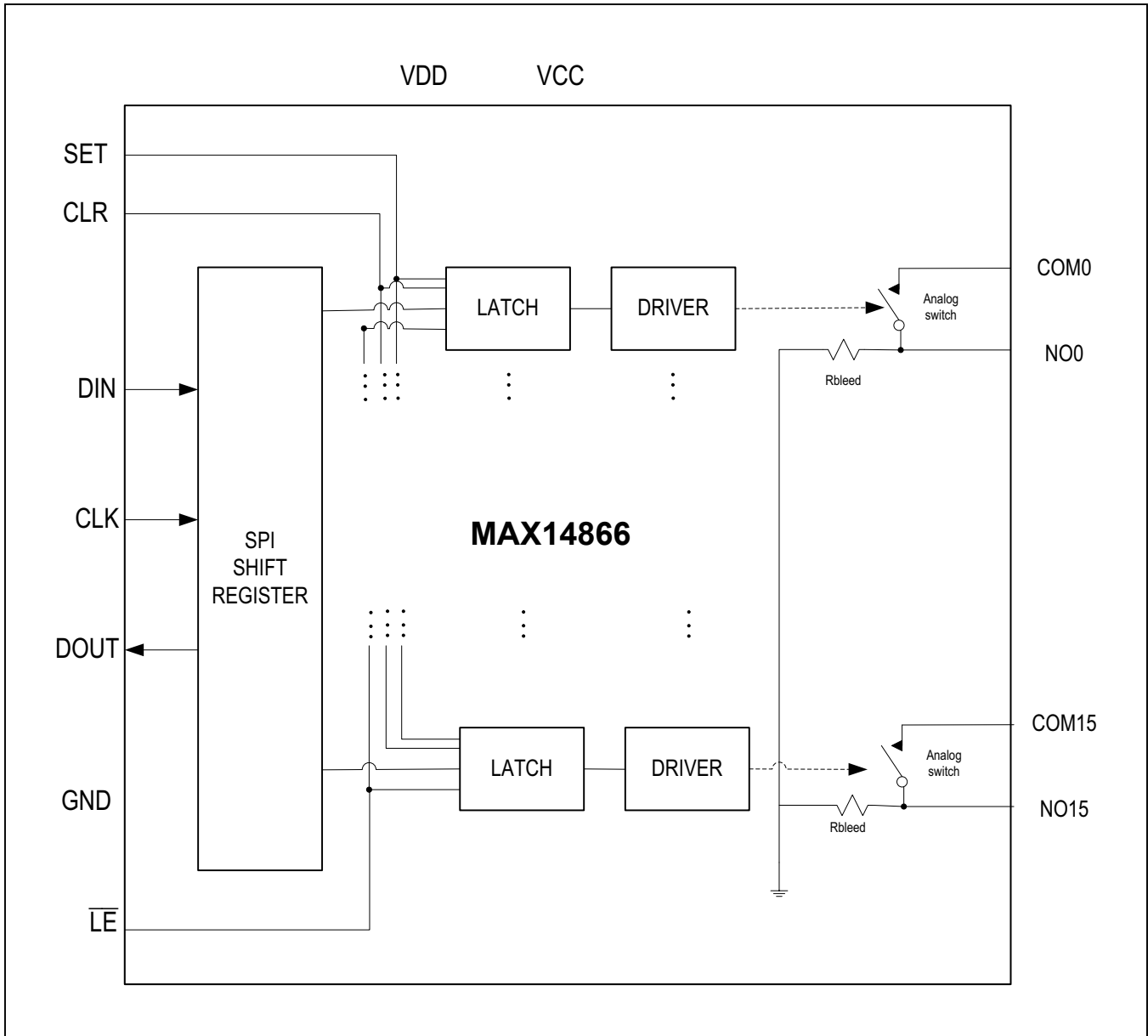

## Detailed Description

The MAX14866 is a 16-channel, high-voltage (HV), Analog SPST switch primarily intended for HV multiplexing in ultrasound applications.

The MAX14866 operates from one only low voltage supply (+5V) and does not require dedicated HV supplies resulting in cost saving and system simplification. Moreover, for in-probe applications, HV supplies do not need to be associated with the MAX14866 in the probe/transducer head, resulting in greater safety and easier compliance to safety regulations.

The MAX14866 features best-in-class performances in terms of bandwidth (up to 50MHz), charge injection (<100pC) and linear transmit input range (up to 210V<sub>PKPK</sub>). The low signal switch  $R_{DSON}$  is typically about 7 $\Omega$  around 0V and remains flat in the entire input range ensuring extremely good linearity.

The latch-up free SOI (Silicon-on-Insulator) technology and the wide analog range results in extremely high robustness during undershoots and overshoots which occur in ultrasound systems due to the resonant nature of the load.

The status of the switches can be individually controlled through a high speed SPI interface (up to 30MHz). Daisy-chain architecture is supported.

Alternatively, switches can also be controlled with global control signal (SET and CLR) for bank selections or relay replacement applications.

The MAX14866 is offered in two different packages: wafer-level package (WLP) and Thin-QFN (TQFN). The 110-Bump WLP size is only 5.53 x 5.47mm, resulting in less than 1.9mm<sup>2</sup>/channel footprint and allowing for very high levels of integration which is beneficial especially for in-probe applications.

The size of the TQFN package is an industry standard 48-pin 7mm x 7mm package.

## Analog Switches

The MAX14866 can transmit undistorted analog signals up to 210V<sub>P-P</sub>. For reliable operation, the maximum drop between input and output of the switch (pins COM and NO) must be less than 110V (refer to the absolute maximum rating in the [Electrical Characteristics](#) table)

It is required that the input signal is set at GND prior to HV transmission. The minimum guaranteed transmit frequency is 500KHz. The switch is not symmetrical. Transducer elements must be connected to pin named NO<sub>x</sub> (x = 0..15) while the transmit/receive front end circuits must be connected to the pin named COM<sub>x</sub> (x = 0..15). Refer to the [Typical Application Circuit](#) for further details.

## Voltage Supply

The MAX14866 operates from a low voltage supply  $V_{CC} = +5V \pm 5\%$ , and a logic supply  $V_{DD}$  (from +1.7V to +5.5V). In particular, if the logic high level of the control input signals (SPI, CLR, SET) is +5V, the two supply voltage inputs  $V_{DD}$  and  $V_{CC}$  can be connected together and the part can operate from one single +5V supply.

Local bypassing on supply voltage inputs is required ( $C > 100nF$ ).

## Bleed Resistors

The MAX14866 features integrated bleed resistors. Bleed resistors are intended to fully discharge the transducers and eliminate any voltage built up. The bleed resistor values depends on the status of the switch. Refer to the [Electrical Characteristics](#) table and to [Figure 1](#) for further details.

## Heading RST

The MAX14866 Equivalent Electrical Circuit is shown in [Figure 1](#) under different conditions depending on the status of the switch (on/off) and on the level of the signal (small-signal/large-signal).

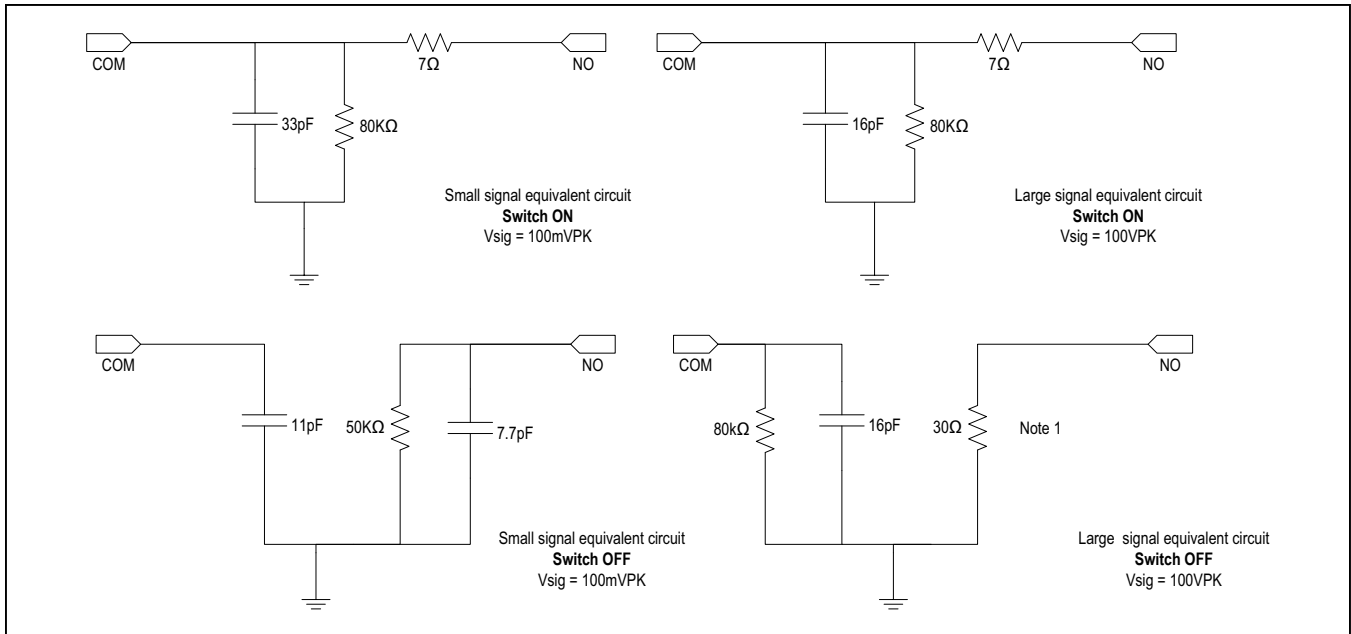

Figure 1. Electrical Equivalent Circuit

**Note 3:** The large-signal NO equivalent input impedance (30Ω typical) is shown for completeness only. It is intended that the High Voltage excitation signals are applied to terminal COM only so that no any HV transmit burst will hit terminal NO whenever the switch is programmed off.

**Note 4:** Resistances and capacitances values are typical.

**Transmit Operations: High-Voltage Bursts (Voltage Amplitude Greater Than 20V<sub>PKPK</sub>)**

The MAX14866 is capable of transmitting long High Voltage Bipolar Bursts (from 40V<sub>PKPK</sub> to 210V<sub>PKPK</sub>) with excellent linearity and stability. When transmitting Bipolar HV bursts (amplitude greater than 20V<sub>PK</sub>) the device is not sensitive to the DC content of the signal.

In particular, the MAX14866 supports long burst excitation modes like the ones commonly used in Elastography. The user must ensure that the total dissipated power can be handled by the package.

Unipolar transmission is supported up to 100V<sub>pk-to-pk</sub> only.

For reliability reasons, it is requested that both the switch input and output (COM and NO pins) are set at ground before the transmission is initiated.

**Transmit Operations: Continuous Wave**

Bipolar Continuous Wave Operation (CW) is supported for transmit voltages less than 20V<sub>PKPK</sub> (amplitude less than 10V). It is required that the DC content (offset) of the CW transmit waveform is less than ±1V. Larger DC

offsets during CW operation results in signal degradation and can affect the device reliability. In particular, unipolar CW operation is not supported.

**Serial Interface**

The MAX14866 is controlled by a serial interface with a 16-bit serial shift register and transparent latch. Each of the 16 data bits controls a single analog switch (see Table 1). Data on DIN is clocked with the most significant bit (MSB) first into the shift register on the rising edge of CLK. Data is clocked out of the shift register onto DOUT on the rising edge of CLK. DOUT reflects the status of DIN, delayed by 16 clock cycles (see Figure 2 and Figure 3).

Changing the switch status (from on to off or vice-versa) during the transmission of the analog signal is not permitted and can result in reliability issues. The user must ensure that the analog input is kept quiet at GND before any SPI programming session and during the entire settling time of the switches (T<sub>ON</sub>, T<sub>OFF</sub>). Similarly the user must ensure that the analog input is quiet at GND before asserting either the CLR or the SET signal and during the entire settling time of the switches (T<sub>ON</sub>, T<sub>OFF</sub>).

Table 1. SPI Programming and Logic Table

DATA BITS								CONTROL BITS								FUNCTION		
D0 (LSB)	D1	D2	D3	D4	D5	D6	D7	$\overline{LE}$	CLR	SET	SW0	SW1	SW2	SW3	SW4	SW5	SW6	SW7
L								L	L	L	OFF							
H								L	L	L	ON							
	L							L	L	L		OFF						
	H							L	L	L		ON						
		L						L	L	L			OFF					
		H						L	L	L			ON					
			L					L	L	L				OFF				
			H					L	L	L				ON				
				L				L	L	L					OFF			
				H				L	L	L					ON			
					L			L	L	L						OFF		
					H			L	L	L						ON		
						L		L	L	L								OFF
						H		L	L	L								ON
X	X	X	X	X	X	X	X	H	L	L								
X	X	X	X	X	X	X	X	X	H	X	OFF	OFF	OFF	OFF	OFF	OFF	OFF	OFF
X	X	X	X	X	X	X	X	X	L	H	ON	ON	ON	ON	ON	ON	ON	ON

DATA BITS								CONTROL BITS								FUNCTION		
D8	D9	D10	D11	D12	D13	D14	D15 (MSB)	$\overline{LE}$	CLR	SET	SW8	SW9	SW10	SW11	SW12	SW13	SW14	SW15
L								L	L	L	OFF							
H								L	L	L	ON							
	L							L	L	L		OFF						
	H							L	L	L		ON						
		L						L	L	L			OFF					
		H						L	L	L			ON					
			L					L	L	L				OFF				
			H					L	L	L				ON				
				L				L	L	L					OFF			
				H				L	L	L					ON			
					L			L	L	L						OFF		
					H			L	L	L						ON		

**Table 1. SPI Programming and Logic Table (continued)**

DATA BITS								CONTROL BITS								FUNCTION			
D8	D9	D10	D11	D12	D13	D14	D15 (MSB)	$\overline{LE}$	CLR	SET	SW8	SW9	SW10	SW11	SW12	SW13	SW14	SW15	
						L		L	L	L							OFF		
						H		L	L	L							ON		
							L	L	L	L								OFF	
							H	L	L	L								ON	
X	X	X	X	X	X	X	X	H	L	L	HOLD PREVIOUS STATE								
X	X	X	X	X	X	X	X	X	H	X	OFF	OFF	OFF	OFF	OFF	OFF	OFF	OFF	
X	X	X	X	X	X	X	X	X	L	H	ON	ON	ON	ON	ON	ON	ON	ON	

**Note 5:** The 16 switches operate independently.

**Note 6:** Serial data is clocked in on the rising edge of CLK.

**Note 7:** The switches go to a state retaining their present condition on the rising edge of  $\overline{LE}$ . When  $\overline{LE}$  is low, the shift register data flows through the latch.

**Note 8:**  $D_{OUT}$  is the data output pin of the 16 bits shift register. It always reflects the status of DIN delayed by 16 clock cycles.

**Note 9:** Shift register clocking has no effect on the switch states if  $\overline{LE}$  is high.

**Note 10:** The CLR input overrides all other inputs.

### SPI Programming Inhibition During Transmit

The MAX14866 cannot be programmed during the transmission of HV bursts. The device features a transmit detector circuit. If a transmit input signal greater than  $\pm 2V$  is detected, any SPI programming is inhibited for 4.5 $\mu$ s max. During such an interval any attempts of programming the part via the SPI is ignored and the previous device status is hold. This function prevents faults caused by false programming of the logic due to the large switching noise occurring during HV transmit.

### $\overline{LE}$ description

Drive  $\overline{LE}$  logic-low to change the contents of the latch and update the state of the high-voltage switches (Figure 3). Drive  $\overline{LE}$  logic-high to freeze the contents of the latch and prevent changes to the switch states. To reduce noise due to clock feedthrough, drive  $\overline{LE}$  logic-high while data is clocked into the shift register. After the data shift register is loaded with valid data, pulse  $\overline{LE}$  logic-low to load the contents of the shift register into the latch.

### CLR description

The MAX14866 features a latch clear input. Drive CLR logic-high to reset the contents of the latch to zero and open all switches. CLR does not affect the contents of the data shift register. Pulse  $\overline{LE}$  logic-low to reload the contents of the shift register into the latch.

### SET description

The MAX14866 features a latch set input. Drive SET logic-high to set the contents of the latch to logic-high and close all switches. SET does not affect the contents of the data shift register. Pulse  $\overline{LE}$  logic-low to reload the contents of the shift register into the latch. CLR is dominant with respect to SET.

### Power-On reset

The MAX14866 features a power-on-reset circuit to ensure all switches are open at power-on. The internal 16-bit serial shift register and latch are set to zero on power-up.

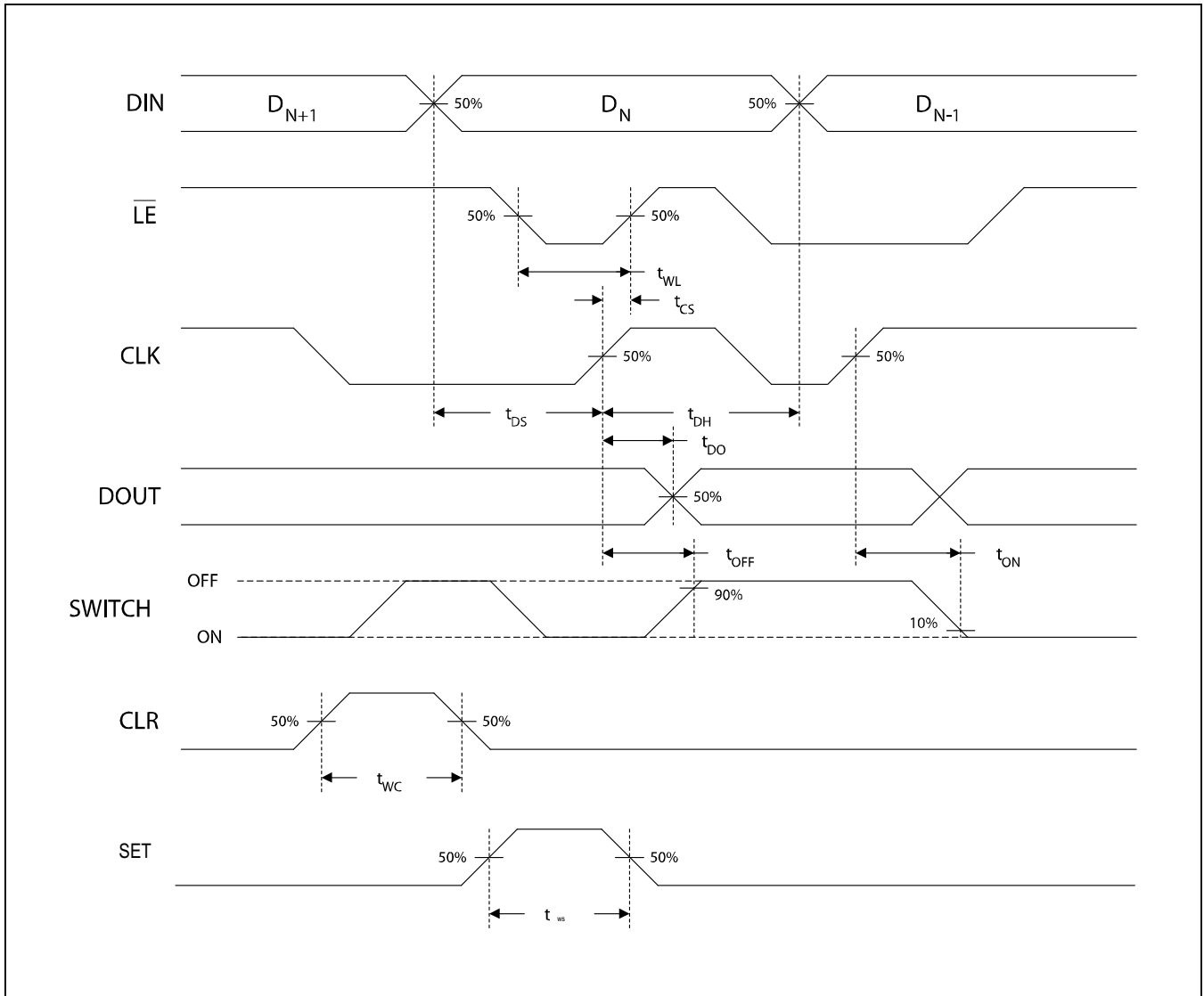

Figure 2. Timings

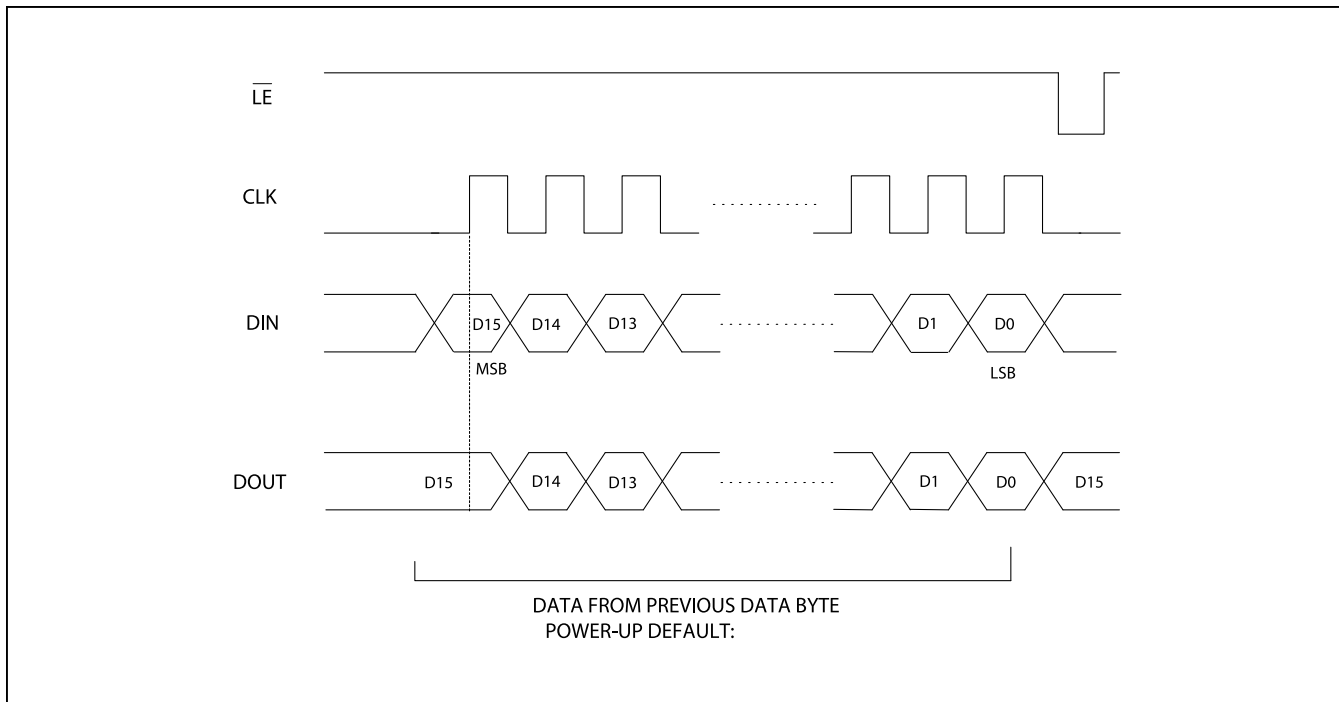
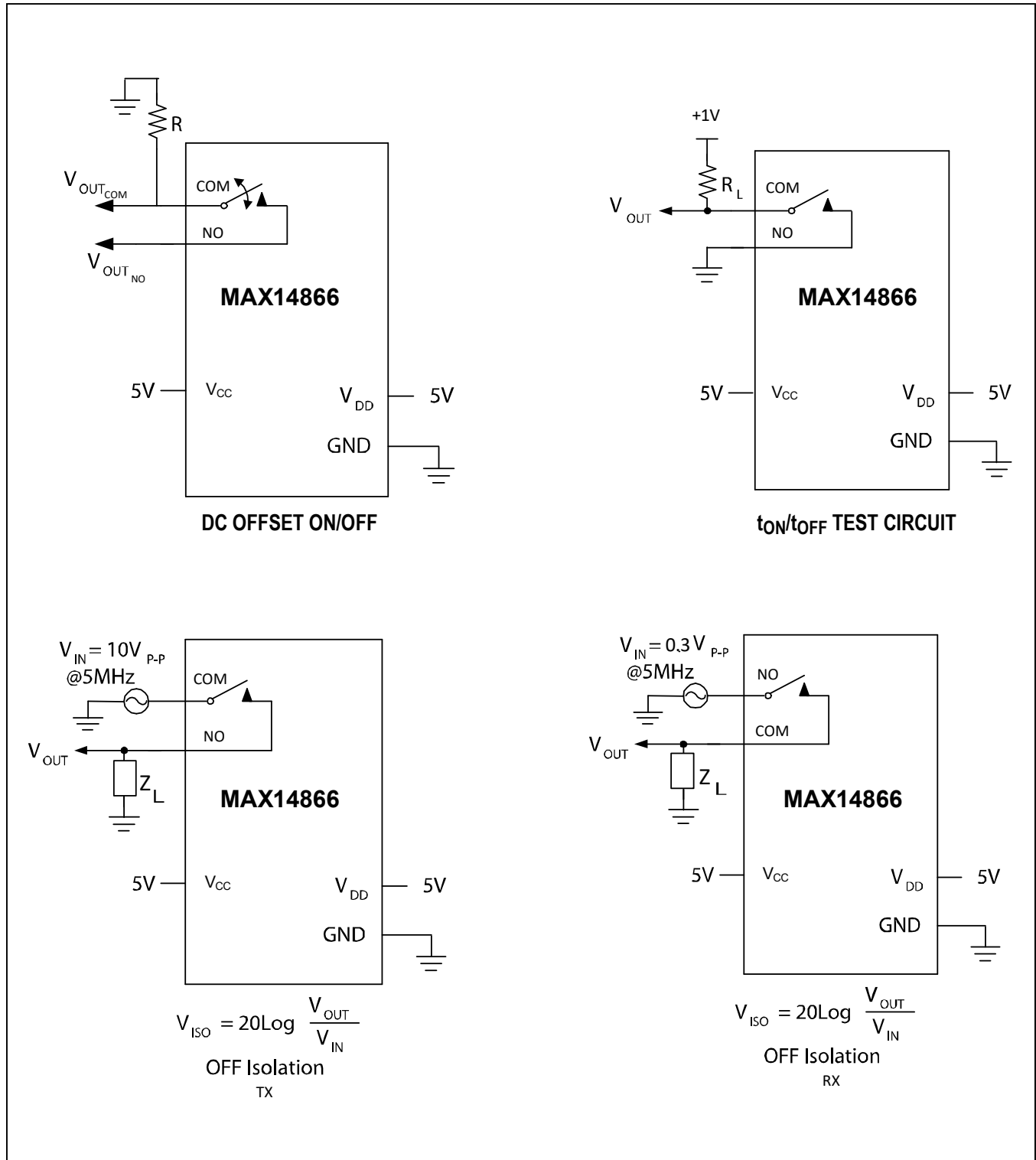
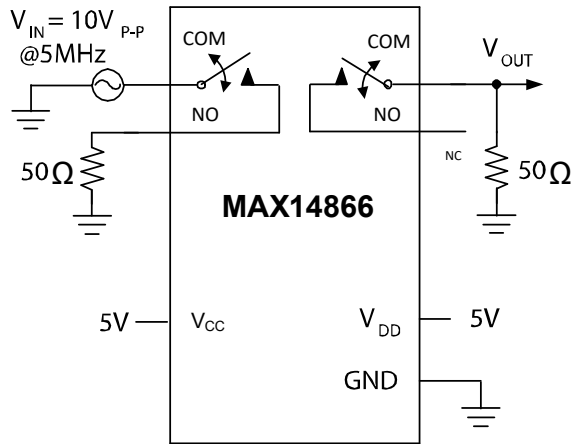

Figure 3. SPI Programming

Test Circuits 1



Test Circuits 2



$$V_{CT} = 20 \text{Log} \frac{V_{OUT}}{V_{IN}}$$

Crosstalk TX

SWITCHES ON OR OFF

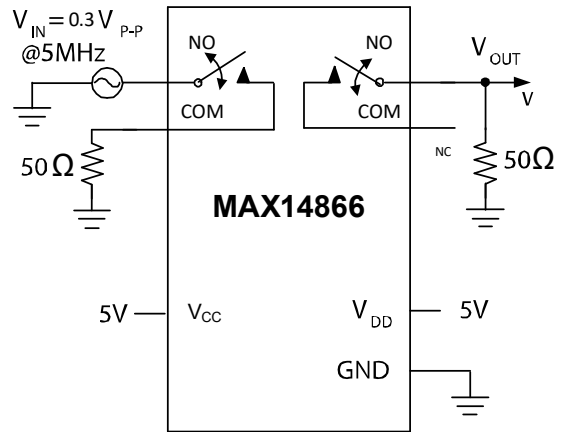

$$V_{CT} = 20 \text{Log} \frac{V_{OUT}}{V_{IN}}$$

Crosstalk RX

SWITCHES ON OR OFF

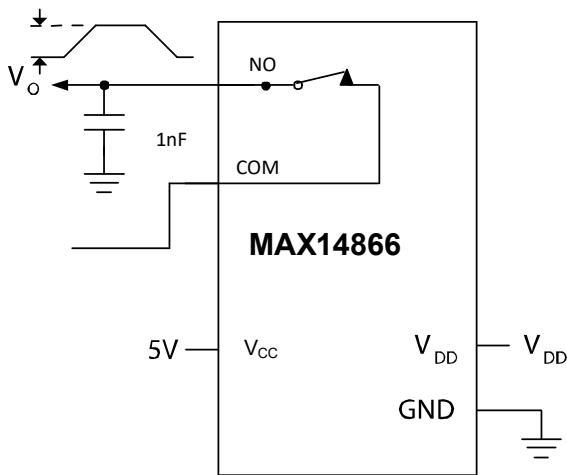

$$Q = 1\text{nF} * V_{OUT}$$

CHARGE INJECTION

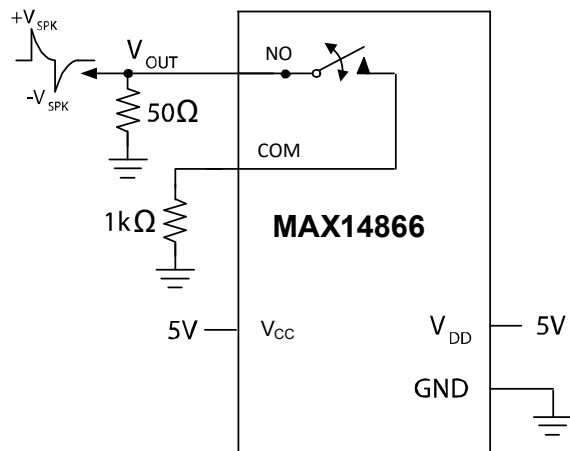

OUTPUT VOLTAGE SPIKE

**Applications Information**

**Power Supply**

The MAX14866 does not require dedicated high-voltage supplies; at a minimum, the device operates from a single LV supply only ( $V_{CC} = V_{DD} = +5V$ ).

$V_{DD}$  (supply voltage input for CMOS logic input) can be set at a lower voltage than  $V_{CC}$  and can vary from +1.8V to +5V depending on the voltage level of CMOS logic signals.

**Logic Inputs**

The MAX14866 digital interface inputs CLK, DIN,  $\overline{LE}$ , CLR, SET operate on the  $V_{DD}$  logic supply voltage.

**Daisy Chain**

Digital output DOUT is provided to allow the programming of multiple MAX14866 devices in daisy-chain configuration (Figure 4). Connect each DOUT to the DIN of the subsequent device in the chain. Connect CLK,  $\overline{LE}$ , CLR, and SET inputs of all devices, and drive  $\overline{LE}$  logic-low to update all devices simultaneously. Drive CLR high to open all the switches simultaneously.

**Banks-Switching Applications**

For relay replacement applications or any application in which the user needs to control the status of all the switches simultaneously so that independent control is not needed (bank selection, bi-plane or triplane probes, multidimensional array etc ..), CLR and SET command can be used to control the status of all the switches simultaneously. Notice that the CLR logic input is dominant with respect to the SET logic input so that CLR = SET = High corresponds to a Clear command (see Table 1). Therefore, in these applications, one only control signal is required since the user can toggle the CLR signal only while the SET input can be tied to  $V_{DD}$ . Whenever the SPI is not used, connect DIN and CLK to GND and  $\overline{LE}$  to  $V_{DD}$  and leave DOUT unconnected.

**Power Sequencing and Bypassing**

The MAX14866 does not require special sequencing of the  $V_{DD}$ ,  $V_{CC}$  supply voltages. Bypass  $V_{DD}$ ,  $V_{CC}$  to GND with greater than 0.1 $\mu$ F ceramic capacitor as close as possible to the device.

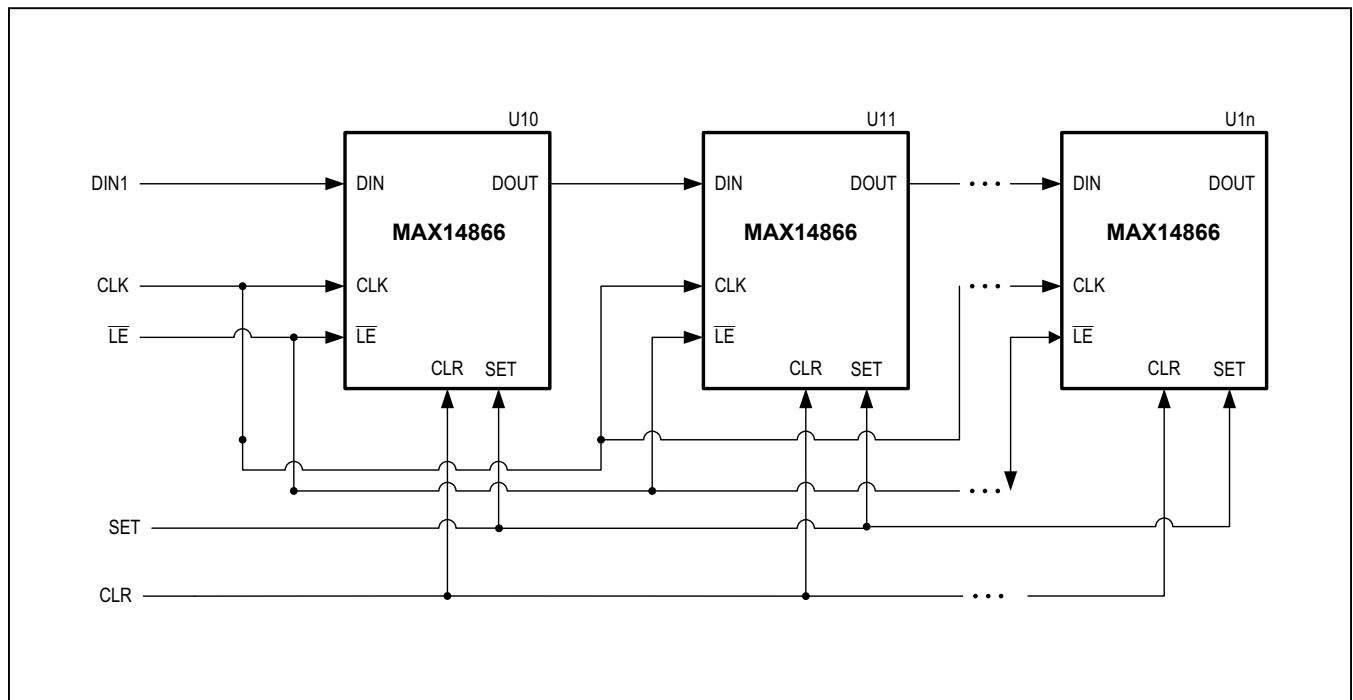

Figure 4. Daisy-Chain Connection

Typical Application Circuit

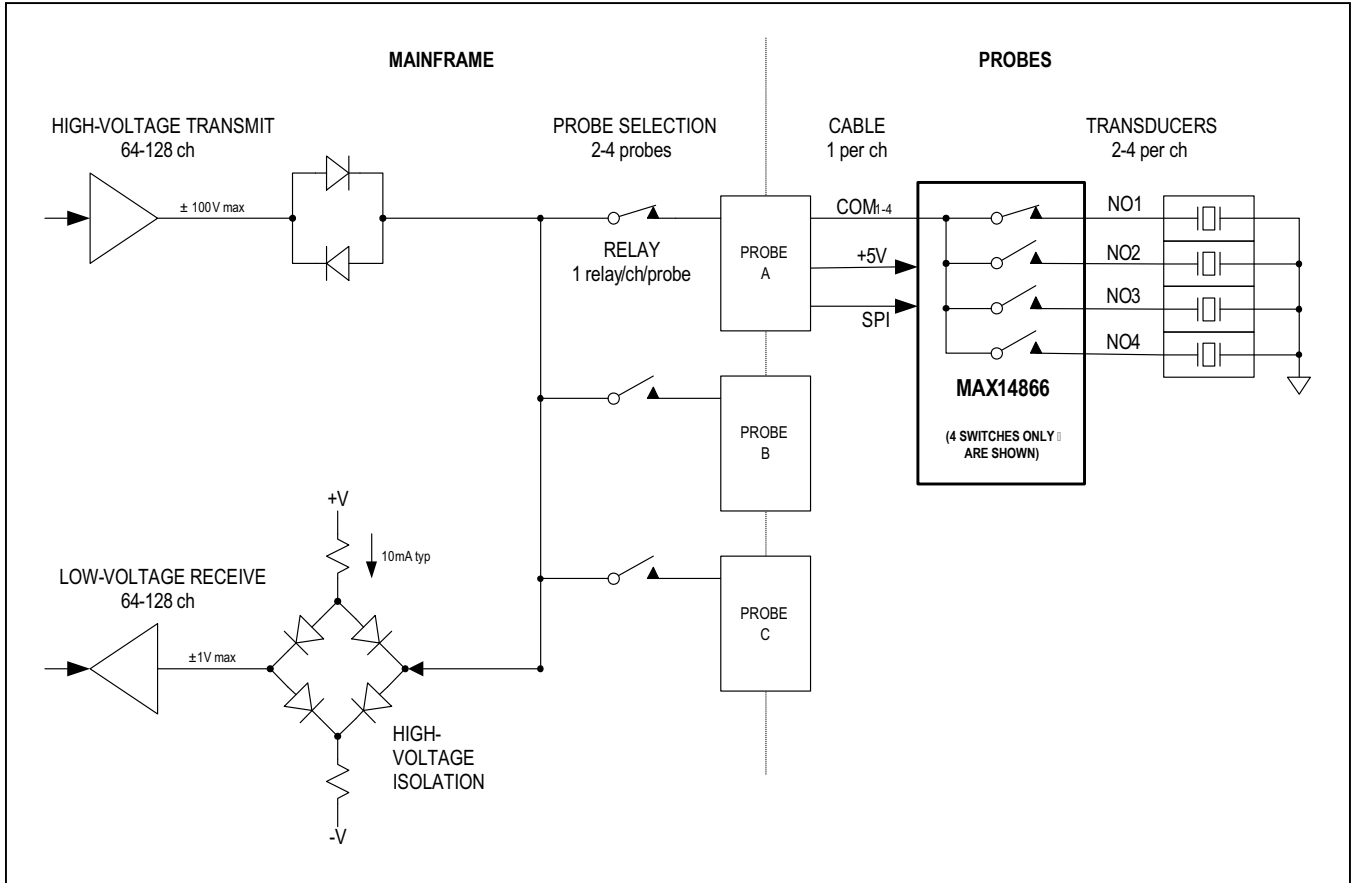

Figure 5. Application Diagram

MAX14866

## 16-Channel, High-Voltage Analog Switch without High-Voltage Supply Requirement

### Ordering Information

PART	TEMP RANGE	PIN-PACKAGE
MAX14866UWZ+	0°C to 85°C	110 WLP (5.47mm x 5.53mm)
MAX14866UTM+	0°C to 85°C	48 TQFN (7mm x 7mm)

+Denotes a lead (Pb)-free package/RoHS-compliant package

### Chip Information

PROCESS: DiCMOS

### Package Information

For the latest package outline information and land patterns (footprints), go to [www.maximintegrated.com/packages](http://www.maximintegrated.com/packages). Note that a "+", "#", or "-" in the package code indicates RoHS status only. Package drawings may show a different suffix character, but the drawing pertains to the package regardless of RoHS status.

PACKAGE TYPE	PACKAGE CODE	OUTLINE NO.	LAND PATTERN NO.
110 Bump WLP	W1105C5+1	<a href="#">21-11001051</a>	Refer to <a href="#">Application Note 1891</a>
48 Pin TQFN	T4877+6	<a href="#">90-0130</a>	Refer to <a href="#">Application Note 1891</a>

MAX14866

16-Channel, High-Voltage Analog Switch  
without High-Voltage Supply Requirement

Revision History

REVISION NUMBER	REVISION DATE	DESCRIPTION	PAGES CHANGED
0	7/17	Initial release	—
1	4/18	Updated <i>Pin Description</i> table	10

For pricing, delivery, and ordering information, please contact Maxim Direct at 1-888-629-4642, or visit Maxim Integrated's website at [www.maximintegrated.com](http://www.maximintegrated.com).

*Maxim Integrated cannot assume responsibility for use of any circuitry other than circuitry entirely embodied in a Maxim Integrated product. No circuit patent licenses are implied. Maxim Integrated reserves the right to change the circuitry and specifications without notice at any time. The parametric values (min and max limits) shown in the Electrical Characteristics table are guaranteed. Other parametric values quoted in this data sheet are provided for guidance.*

## Looking for pricing, stock, or lifecycle information?

Click below to explore more details on WIN SOURCE:

- ⊖ [View MAX14866UTM+T on WIN SOURCE](#)
- ⊖ [Maxim Integrated Information](#)

## Optimize Your Supply Chain with WIN SOURCE Solutions

- ✓ Global Sourcing Solution
- ✓ Obsolete Management
- ✓ Cost Control Management
- ✓ Shortage Management
- ✓ Alternative Solution
- ✓ Excess Inventory Management