



**THE DATASHEET OF  
ADZS-U4050WL-EZKIT**



## ADZS-U4050WL-EZKIT for the **ADuCM4050** Microcontroller

### INTRODUCTION

This user guide describes the ADZS-U4050WL-EZKIT that is used to evaluate the **ADuCM4050** microcontroller. This guide describes the different parts and components of the ADZS-U4050WL-EZKIT evaluation board, as well as the functionalities and configurations of the ADZS-U4050WL-EZKIT that enable the user to develop applications with the device.

### DOCUMENTS NEEDED

[ADuCM4050 EZ-Kit Manual](#)

### GENERAL DESCRIPTION

The **ADuCM4050** is an ultra low power, integrated, mixed signal microcontroller unit (MCU) that is used for processing, control, and connectivity. The MCU system is based on an Arm® Cortex®-M4F processor, which is a 32-bit reduced instruction set computer (RISC) processor and runs up to 52 MHz. The device has 512 kB of embedded flash memory with error correction code (ECC) and 128 kB of system RAM with parity.

The **ADuCM4050** also feature a collection of digital peripherals, and an analog subsystem that provides clocking, reset, and power management capability in addition to an analog to digital converter (ADC) subsystem.

Refer to the **ADuCM4050** product page for future updates.

For full details, see the **ADuCM4050** data sheet, which must be used in conjunction with this user guide when using the evaluation board.

### EVALUATION BOARD PHOTOGRAPH

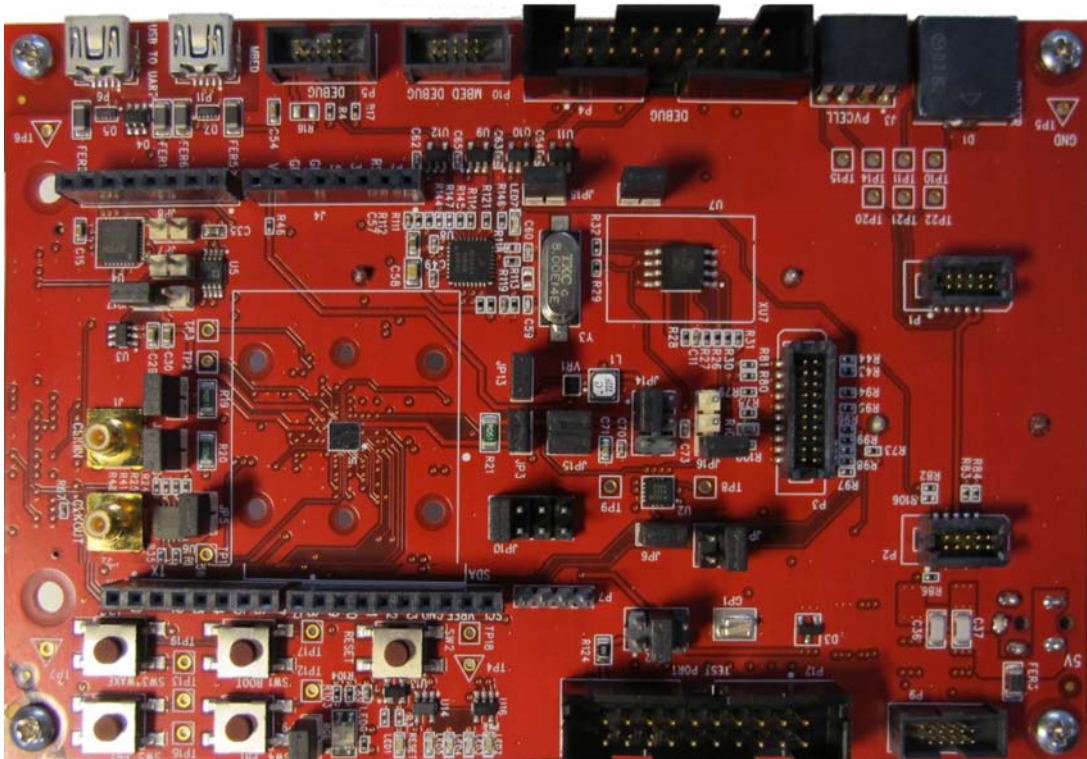

Figure 1. **ADuCM4050** Evaluation Board

**TABLE OF CONTENTS**

Introduction .....	1	Arduino Uno Connectors (J4, J5, J6, J7) .....	8
Documents Needed.....	1	Expansion Interface 3 (EI3) .....	9
General Description .....	1	Wireless Transceivers Interface (P1, P2, and P3).....	10
Evaluation Board Photograph.....	1	Emulation and Serial Interface Connector (P4, P5, and P9) ...	10
Revision History .....	2	ADZS-U4050WL-EZKIT Board System Architecture.....	11
Overview.....	3	ADZS-U4050WL-EZKIT Board Schematic .....	12
Contents.....	3	Ordering Information.....	23
Board Features .....	3	Bill of Materials.....	23
ADZS-U4050WL-EZKIT Board Connectors.....	8		

**REVISION HISTORY**

5/2018—Revision 0: Initial Version

## OVERVIEW

The ADZS-U4050WL-EZKIT allows the user to program, debug, and evaluate the performance of the [ADuCM4050](#) microcontroller.

## CONTENTS

The ADZS-U4050WL-EZKIT package contains the following items (see Figure 2):

- ADZS-U4050WL-EZKIT board
- USB 2.0 cable
- J-Link LITE emulator



Figure 2. ADZS-U4050WL-EZKIT Package Contents

### J-Link LITE Emulator

The J-Link LITE emulator board provides a debug path interface via serial wire, power supply, and UART communication with the ADZS-U4050WL-EZKIT board. Figure 3 shows a top view of the emulator board.

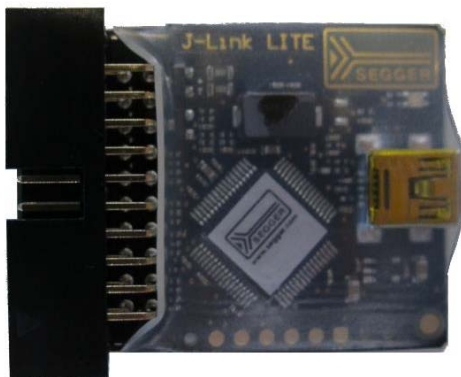

Figure 3. J-Link Lite Emulator

The serial wire debug connector is a 20-pin device, but only three connections are made: SWDIO and SWCLK are used for debug purposes and the RESET connection is used to provide a reset from the PC if required. Table 1 shows the JTAG connector pin configuration.

Table 1. JTAG Connector Pinouts

Pin Number	Signal
4, 6, 8, 10, 12, 14, 16, 18, 20	GND
1	VDD
7	SWDIO
9	SWCLK
15	RESET

When measuring current consumption using an external supply on the ADZS-U4050WL-EZKIT board IOVDD pins, it is recommended that the emulator be disconnected.

The connection on the board is used in P4, which is a debug port.

## BOARD FEATURES

### Power Supply

The ADZS-U4050WL-EZKIT evaluation board can be powered by numerous sources to evaluate the capability of the [ADuCM4050](#) microcontroller.

The following sources are the options for powering the board:

- External power supply. The ADZS-U4050WL-EZKIT board package has a 5 V dc regulated power adaptor included. To use the adapter to supply the microcontroller, Pin 3 and Pin 5 of JP12, and Pin 1 and Pin 3 of JP14 must be shorted; then, connect the adaptor to the P8 power jack.
- J-Link LITE emulator. The J-link lite emulator can be used to power the evaluation board while debugging and programming the microcontroller. Pin 1 and Pin 3 of JP12 and Pin 1 and Pin 3 of JP14 must be shorted to use this option. To power the board by this option, you must also command the J-Link LITE to power the board. Run the J-Link LITE commander, and then execute the **power on perm** command.
- USB power supply. The ADZS-U4050WL-EZKIT board can draw power from the USB to the UART port on the lower right side of the board. The configuration for this setup is shorting Pin 3 and Pin 4 of JP12 and Pin 1 and Pin 3 of JP14.
- USB mbed. The ADZS-U4050WL-EZKIT board can draw power from the USB to the mbed interface on the lower side of the board. The configuration for this setup is shorting Pin 3 and Pin 4 of JP12 and Pin 1 and Pin 3 of JP14.
- Coin cell battery. The ADZS-U4050WL-EZKIT board can be powered by a 3 V coin cell battery (included in the kit). To use the coin cell battery, Pin 1 and Pin 2 of JP16 and Pin 3 and Pin 4 of JP14 must be shorted.

- AA battery. To use an AA battery, Pin 2 and Pin 3 of JP16 and Pin 3 and Pin 4 of JP14 must be shorted.
- Photovoltaic (PV) cell. The ADZS-U4050WL-EZKIT board can be also be powered by energy harvesting kits by Analog Devices, Inc. To use this option, Pin 3 and Pin 5 of JP14 must be shorted.

The configuration for the power options are listed in Table 2. The numbers indicate the pins to be shorted.

The 5 V sources (external power, emulator, and USBs) are connected to the on-board 3.0 V low dropout (LDO) regulator before they power the components and the microcontroller in the board.

The battery and the PV cell supplies are directly connected to the ADZS-U4050WL-EZKIT internal components (microcontroller, flash, temperature sensor, and accelerometer). Do not supply more than 3.6 V on the battery and PV cell terminals to avoid damaging the microcontroller.

**Table 2. Power Option Configuration of ADZS-U4050WL-EZKIT Board**

Source	Pin Number		
	JP12 <sup>1</sup>	JP14	JP16 <sup>1</sup>
External Power Adapter	3, 5	1, 3	X
Emulator/J-Link LITE	1, 3	1, 3	X
USB Power	3, 4	1, 3	X
USB mbed	3, 4	1, 3	X
Coin Cell Battery	X	3, 4	1, 2
AA Battery	X	3, 4	2, 3
PV Cell	X	3, 5	X

<sup>1</sup> X means don't care.

**Power Indicator/General-Purpose LEDs**

The ADZS-U4050WL-EZKIT board has seven light emitting diodes to indicate different board statuses. LED1 (red) indicates if the board has been reset. LED2 (green) indicates that the board is powered up. LED7 (yellow) indicates mbed enabled.

The general-purpose yellow LEDs (LED3, LED4, and LED5) are programmable and connected to the pins of the microcontroller. These are all active low LEDs; this means that writing low to the pins where the LED is connected lights up the LEDs.

The red, green, blue (RGB) LED (LED6) is a multicolor LED, which internally uses three monochrome LEDs, one per primary color, in order to combine the lights to create new colors. The monochrome LEDs can be controlled independently from the microcontroller. JP9 must be closed.

The LED to pin connections are described in Table 3.

**Table 3. LED to MCU Pin Connections**

LED No.	Pin No.
LED1	SYS_HWRST
LED2	Not applicable, LED2 is directly connected to the power line
LED3	P0_13
LED4	P1_12
LED5	P1_13
LED6	P1_06, P1_07, P1_08
LED7	Not applicable, LED7 is controlled by mbed circuit

**Crystal Circuits**

The ADZS-U4050WL-EZKIT board uses two crystals to clock the system: a 26 MHz and a 32.768 kHz crystal. The 26 MHz crystal is a possible clock source for the full system such as the core, SRAM, bus, flash, and others. The 32.768 kHz crystal is a possible clock source of the low frequency multiplexer (LFMUX), connected to the low speed peripherals, such as the beeper controller or timers.

**Emulator Interface**

Application, download, and emulation are possible on the ADuCM4050 via serial wire by using the J-Link LITE emulator through the P4 connector of the ADZS-U4050WL-EZKIT board.

**Reset/Wake/Boot/General-Purpose Push-Buttons**

The ADZS-U4050WL-EZKIT board has five push-buttons (see Figure 4) that are responsible for different operations.

- The boot mode select switch (SW1) determines the boot mode of the processor. By default, the processor boots from the internal flash memory. When pressed, the UART download mode is triggered. See the [ADuCM4050 EZ-Kit Manual](#), Revision 1.0 for further information which can be found in the **Documentation** section of the [ADuCM4050](#) product page (this manual is included in the downloadable board support package for the [ADuCM4050](#)).

- The reset switch (SW2) resets the [ADuCM4050](#) processor.
- The wake switch (SW3) is connected to the processor wake signals, and is used to wake up the processor during low power modes. Depending on the configuration of JP10, the different external interrupts are used to wake up the microcontroller.
- Table 4 shows which pins must be shorted on JP10 to choose which external interrupt is connected to the WAKE switch.
- The PB1 switch (SW4) is a general-purpose switch that is connected to the GPIO P2\_09.
- The PB2 switch (SW5) is a general-purpose switch that is connected to the GPIO P2\_06.

**Table 4. External Interrupt Choice for the WAKE Switch**

Pin Number	Signal Name
1, 2	SYS_WAKE0
3, 4	SYS_WAKE1
5, 6	SYS_WAKE2
7, 8	SYS_WAKE3

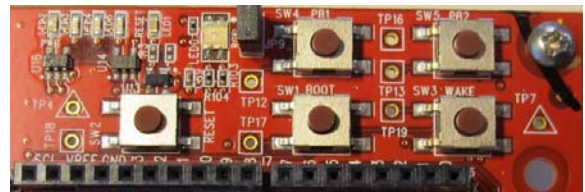

Figure 4. ADZS-U4050WL-EZKIT Push Buttons Located Near the LEDs

**USB to UART Interface**

The ADZS-U4050WL-EZKIT has an on-board USB to UART interface circuit used to connect the [ADuCM4050](#) microcontrollers to a PC. The USB to UART functionality is provided by an FT232RQ (U4) chip. The chip handles the entire USB protocol on-chip and no USB firmware development is required. The FT232R can transfer data at rates from 300 baud to 3 Mbaud at transistor to transistor (TTL) levels.

The UART0 pins of the [ADuCM4050](#) microcontrollers are connected directly to the interface pins of the FT232RQ chip (U4). If another USB to UART module is used, the UART1 signals can be tapped on the P7 4 × 1 header.

**mbed Interface**

mbed is a platform based on Cortex-M that features several components, where there are several components, an operating system and protocols. One of these components is the programming interface (CMSIS-DAP compliant).

The ADZS-U4050WL-EZKIT board has a programming interface, which enables the device to be programmed and debugged via the USB. When connected to a PC, an external unit called DAPLINK and a new COM port appear; if not, installing the mbed Windows® Serial Port Driver is required. For further information, see the ARM mbed web page.

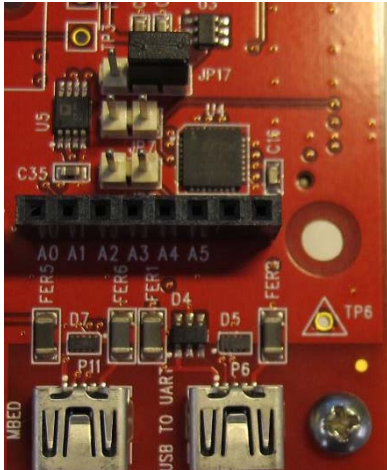

Figure 5. USB to UART Circuit (Right) and USB to mbed Circuit (Left)

**On-Board, Trisensor Circuit (Accelerometer, Temperature, and ADC)**

The ADZS-U4050WL-EZKIT board has an on board, trisensor circuit that consists of a 3-axis, micro electromechanical systems (MEMS) accelerometer, a temperature sensor, and an ADC; which is provided by the ADXL363 (U2), as shown in Figure 6.

The entire system consumes less than 2  $\mu$ A at a 100 Hz output data rate and 270 nA that triggers the wake-up mode when in motion. The ADXL363 communicates with the ADuCM4050 microcontroller via the serial port interface (SPI2). The accelerometer provides selectable measurements of 2G, 4G, and 8G with a resolution of 1 mG/LSB on the 2G range. The temperature sensor operates with a scale factor of 0.065°C. The ADC has no external connections, but can be used by tapping to TP8 test point. This circuit can be powered down by unshorting the JP6 header.



Figure 6. Trisensor Circuit

**On-Board, Digital I<sup>2</sup>C Temperature Sensor**

The ADZS-U4050WL-EZKIT board has an on-board, I<sup>2</sup>C digital temperature sensor, ADT7420. The ADT7420 (U6) is rated for operation over the -40°C to +150°C temperature range.

The ADT7420 operates from 2.7 V to 5.5 V. Operating at 3.3 V, the average supply current is typically 210  $\mu$ A and the shutdown current is typically 2.0  $\mu$ A.

The ADT7420 has two available pins for address selection with four possible I<sup>2</sup>C addresses. The user can configure the address by soldering resistors in R39 and R40 (to VCC), and R41 and R42 (to GND). The default address is 0x48.

The ADT7420 is connected to the I<sup>2</sup>C0 interface and can generate an interrupt signal to interrupt the microcontroller. The interrupt signal pin of the ADT7420 is connected to Pin P1\_14 of the ADuCM4050.

The temperature sensor can be disconnected from the board supply by unshorting the JP5 header. Figure 7 shows the circuit with the ADT7420 chip in the middle and the JP5 header above the chip.

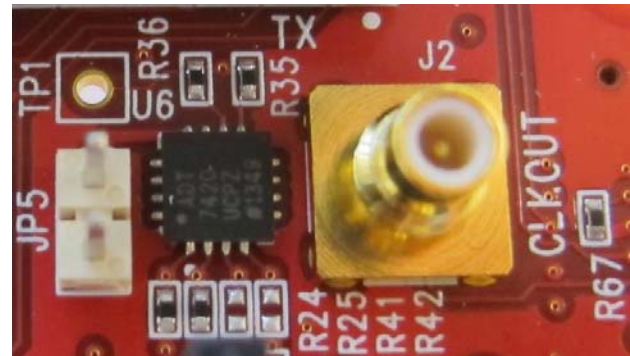

Figure 7. I<sup>2</sup>C Temperature Circuit

**On-Board, 32 Mb Serial Flash Memory**

The ADZS-U4050WL-EZKIT board has an on-board, serial flash memory that can be used to store voice, text, and data.

The serial flash memory (U7) is a W25Q32 chip that has a storage size of 32 Mb. The chip supports a standard serial peripheral interface (SPI) with speeds up to 104 MHz. The chip is interfaced with the SPI2 of the microcontroller and can be disconnected to the board by unshorting the JP4 header.

Figure 8 shows the circuit with the W25Q32 chip in the middle and the JP4 header below the flash chip.

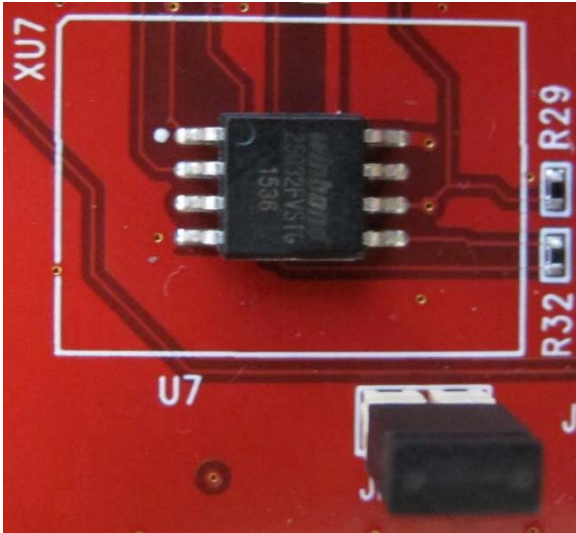

Figure 8. External 32 Mb Serial Flash Memory

**On-Board Buzzer**

The ADZS-U4050WL-EZKIT has a buzzer (D1) that can be used to generate tones and alarms with the beeper controller inside the ADuCM4050 microcontroller. Figure 9 shows the buzzer chip next to the PV cell connector.

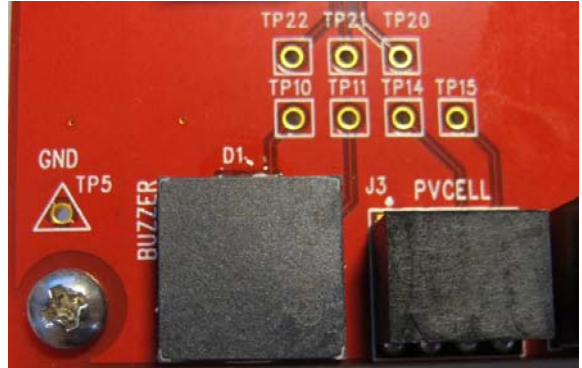

Figure 9. Buzzer Circuit

## ADZS-U4050WL-EZKIT BOARD CONNECTORS

The ADZS-U4050WL-EZKIT board has a number of connectors used to connect different boards and kits for evaluation. The locations of these connectors are described in Figure 10.

### ARDUINO UNO CONNECTORS (J4, J5, J6, J7)

The ADZS-U4050WL-EZKIT board has an Arduino Uno compatible form factor interface that can accept Arduino shields and daughter boards. The pinout of the Arduino interface is described in Table 5 to Table 8.

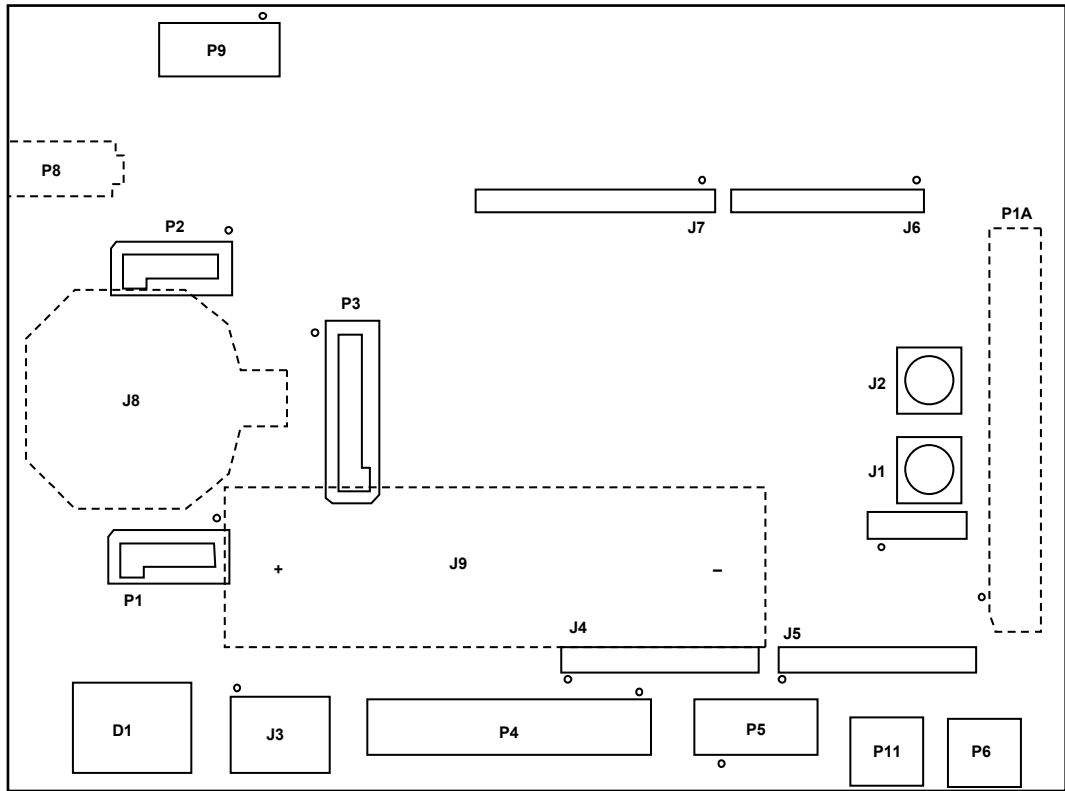

Figure 10. Connector Locations

Table 5. Arduino Interface J4 Connector Pinout

J4 Pin Number	Arduino Pin Name	ADuCM4050 Pin Name
1	No Connect	Not applicable
2, 4	3V	Not applicable
3	RST	SYS_HWRST
5	5V	Not applicable
6, 7	GND	Not applicable
8	VIN	Not applicable

Table 6. Arduino Interface J5 Connector Pinout

J5 Pin Number	Arduino Pin Name	ADuCM4050 Pin Name
1	A0	ADC0_VIN0 (P2_03)
2	A1	ADC0_VIN1 (P2_04)
3	A2	ADC0_VIN2 (P2_05)
4	A3	ADC0_VIN3 (P2_06)
5	A4	ADC0_VIN4 (P2_07)
6	A5	ADC0_VIN5 (P2_08)
7	Not applicable	P1_03/GPIO19/SPI2_MOSI
8	Not applicable	P1_04/GPIO20/SPI2_MISO

Table 7. Arduino Interface J6 Connector Pinout

J6 Pin Number	Arduino Pin Number	ADuCM4050 Pin Name
1	0	P0_11/UART0_RX
2	1	P0_10/UART0_TX
3	2	P0_15/GPIO15/SYS_WAKE0
4	3	P2_11/GPIO43/SP1_CS1/SYS_CLKOUT/RTC1_OPC1
5	4	P2_01/GPIO33/SYS_WAKE3/TMR2_OUT
6	5	P2_02/GPIO34/SPT0_ACN/SP11_CS2
7	6	P2_00/GPIO32/ADPT0_AFS/UART1_RX
8	7	P0_12/GPIO12/SPT0_AD0

Table 8. Arduino Interface J7 Connector Pinout

J7 Pin Number	Arduino Pin Name	ADuCM4050 Pin Name
1	8	P1_02/GPIO18/SPI2_CLK
2	9	P1_15/GPIO31/SPT0_ACLK/UART1_TX
3	10	P0_03/GPIO03/SPIO_CS0/SPT0_BCNV/SPI2_RDY
4	11	P0_01/GPIO01/SPIO_MOSI/SPT0_BFS
5	12	P0_02/GPIO02/SPIO_MISO/SPT0_BD0
6	13	P0_00/GPIO00/SPIO_CLK/SPT0_BCLK
7	GND	GND
8	AREF	VREF_ADC
9	SDA	P0_05/I2C0_SDA
10	SCL	P0_04/I2C0_SCL



Figure 11. J4 and J5 Arduino Compatible Interface (Power and ADC)

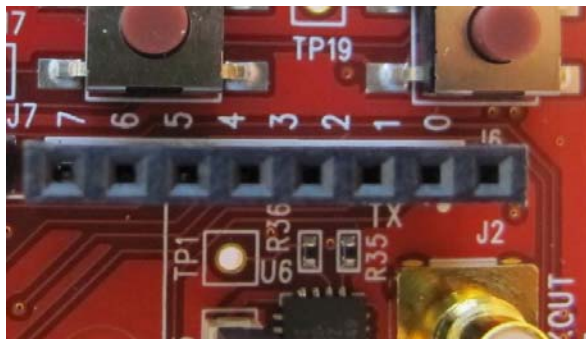

Figure 12. J6 Arduino Compatible Interface (GPIO)

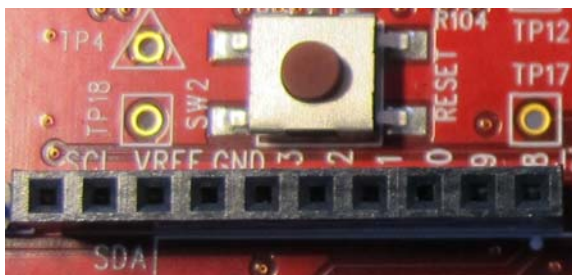

Figure 13. J7 Arduino Header (GPIO Pins, SPI, and I<sup>2</sup>C)

### EXPANSION INTERFACE 3 (EI3)

The ADZS-U4050WL-EZKIT board includes one expansion interface connector located on the bottom side of the board. EI3 supports connection to other EI3 daughter boards designed by Analog Devices, extending the capabilities of the evaluation board. The connectors provide power, ground, RESET, ADC, I<sup>2</sup>C, SPI, UART, serial port (SPORT), and GPIO signals.

An EI3 [SDP breakout board](#) (sold separately), is required to tap and probe the signals in this connector as shown in Figure 15.



Figure 14. EI3 Connector

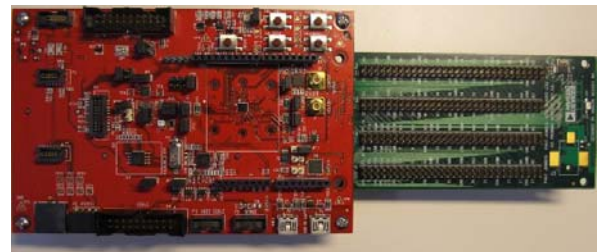

Figure 15. EI3 SDP Breakout Board Connected to the ADZS-U4050WL-EZKIT Board

**WIRELESS TRANSCEIVERS INTERFACE (P1, P2, AND P3)**

The wireless transceiver daughterboard interface supports the [ADF7023](#), [ADF7024](#), [ADF7242](#), [ADF7030](#), and [ADF7030-1](#) wireless transceivers. These are low power, high performance, integrated radio transceivers supporting a wide range of modulation schemes and channel widths in the sub GHz and 2.4 GHz frequency ranges.

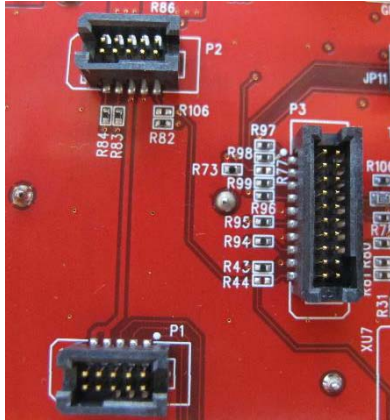

Figure 16. Wireless Transceiver Interface

16130-016

**EMULATION AND SERIAL INTERFACE CONNECTOR (P4, P5, AND P9)**

The P4, P5, and P9 connectors provide a connection from the ADZS-U4050WL-EZKIT board to the emulator board. P4 is a 20-pin, standard JTAG connector that is compatible with the J-Link LITE emulator.

P5 and P9 are 10-pin, debug/emulator connectors with serial wire, power source, and UART signal lines for debugging purposes.

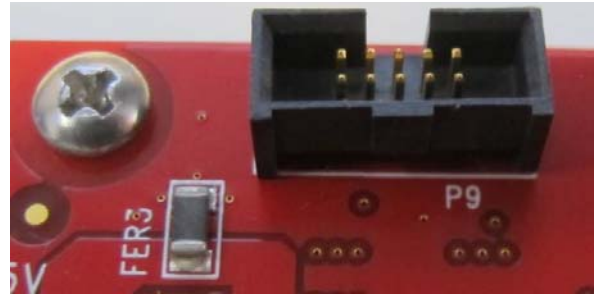

Figure 17. P9 Debug Connector

16130-017



Figure 18. P4 and P5 Debug Connectors

16130-018

# ADZS-U4050WL-EZKIT BOARD SYSTEM ARCHITECTURE

Figure 19 shows a block diagram of the ADZS-U4050WL-EZKIT board.

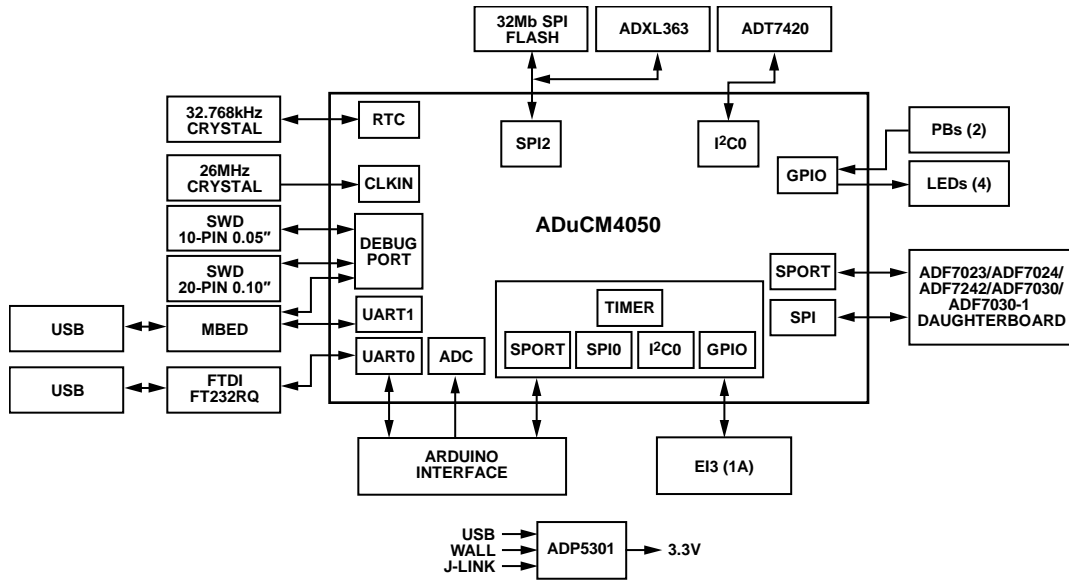

Figure 19. ADZS-U4050WL-EZKIT Board Block Diagram

16130419

# ADZS-U4050WL-EZKIT BOARD SCHEMATIC

Figure 20 through Figure 38 show the schematics of the ADZS-U4050WL-EZKIT board.

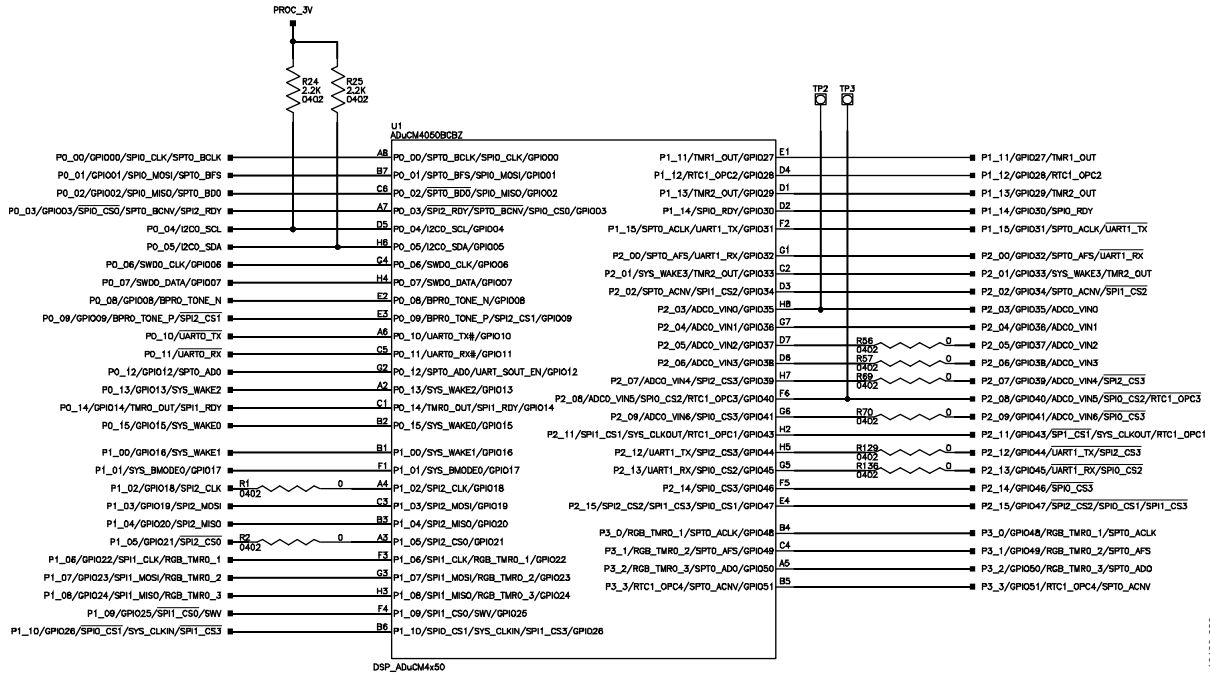

Figure 20. ADuCM4050 Microcontroller GPIO Schematic

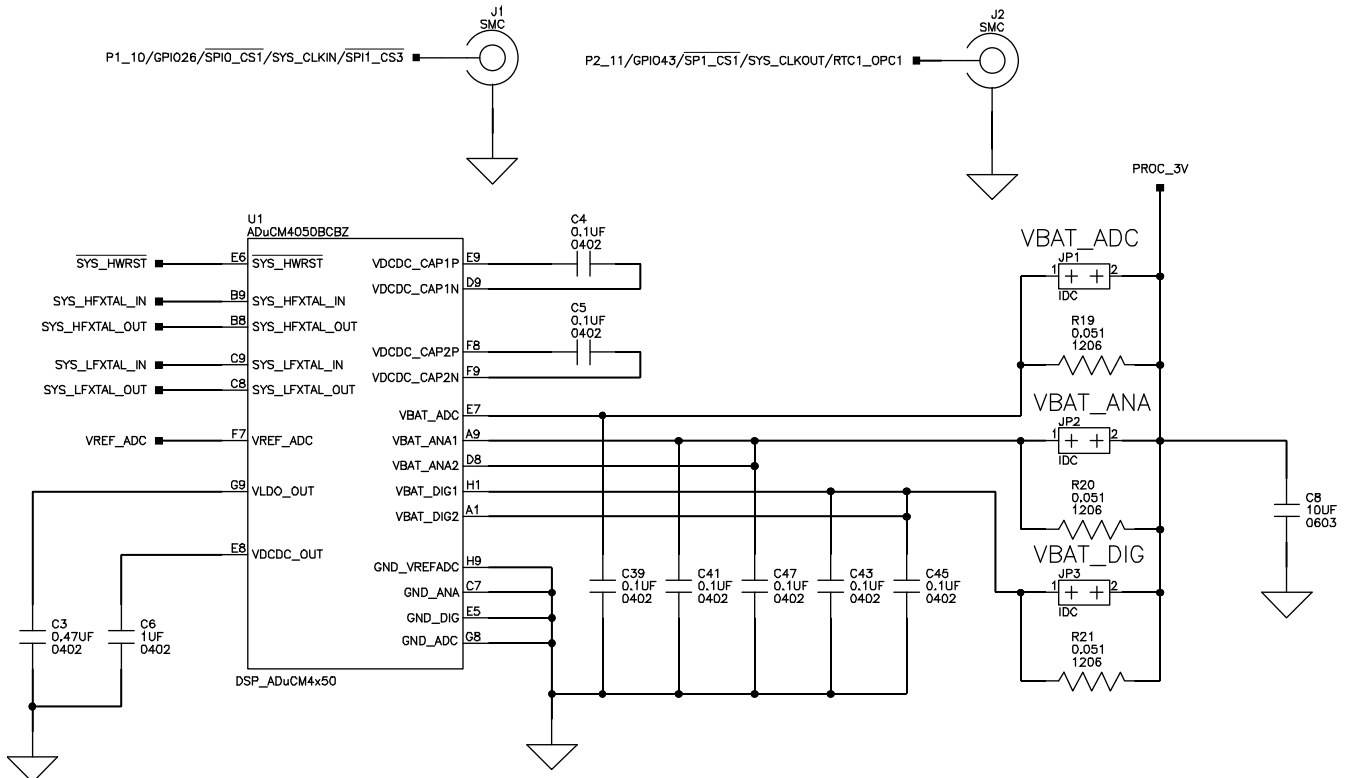

Figure 21. ADuCM4050 Microcontroller Power and External Clock Lines

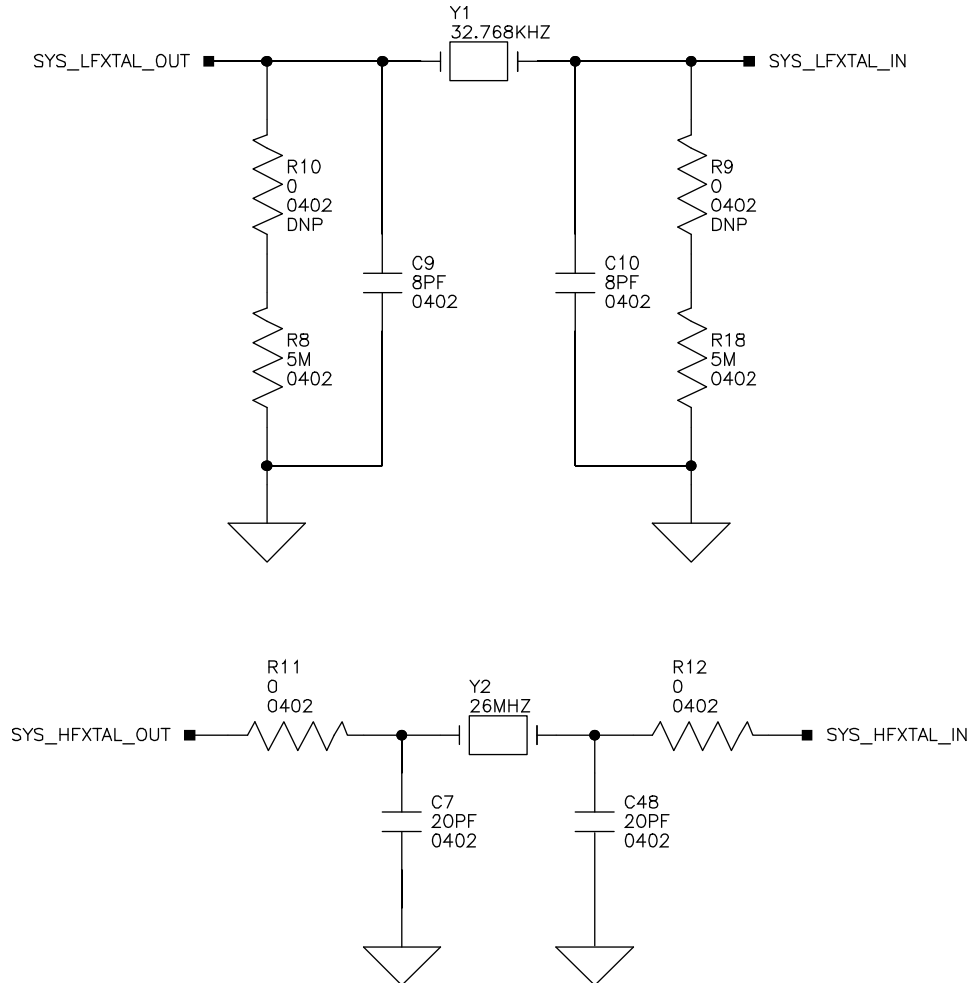

Figure 22. Crystal Circuit Figure

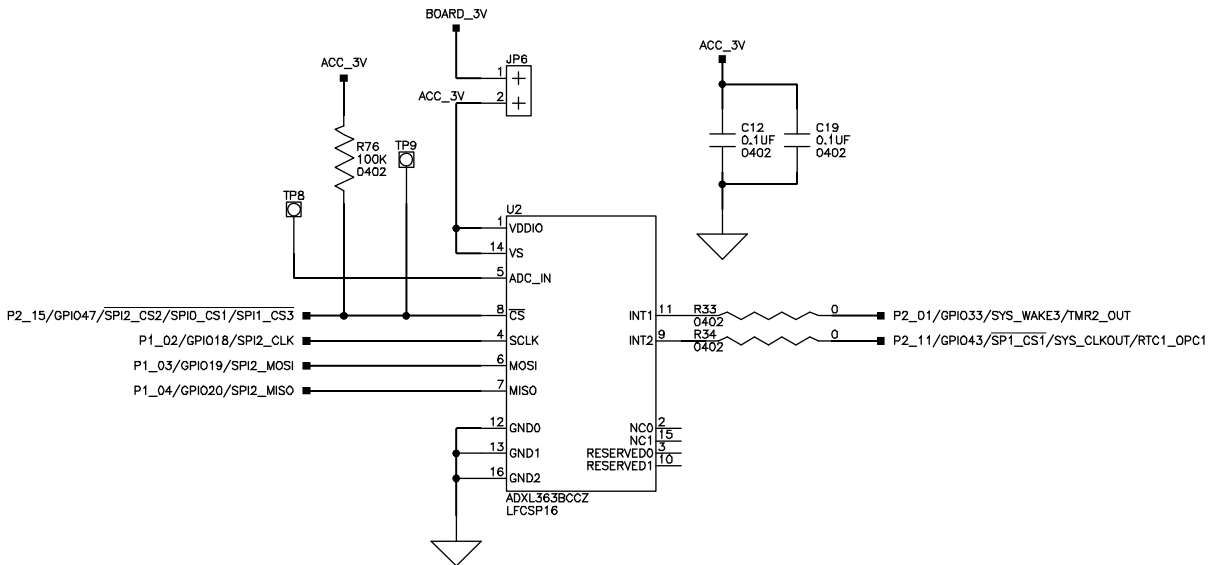

Figure 23. Trisensor Circuit

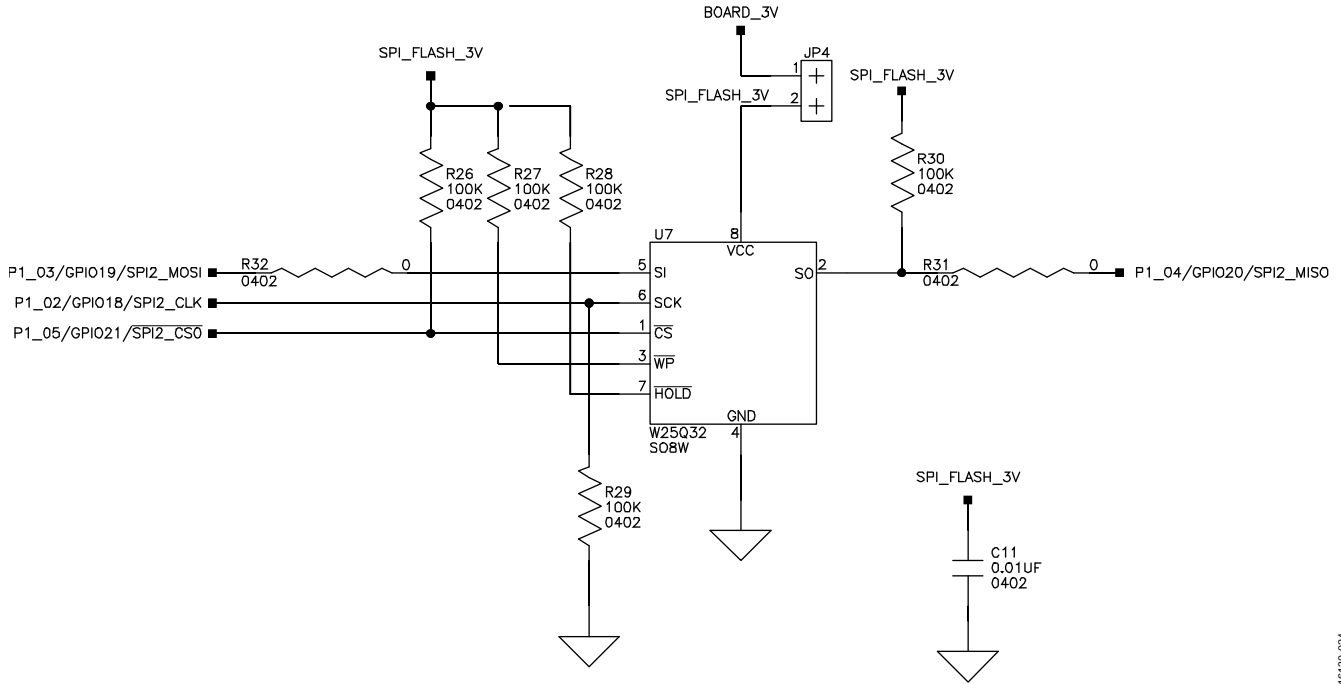

Figure 24. External Flash Circuit Diagram

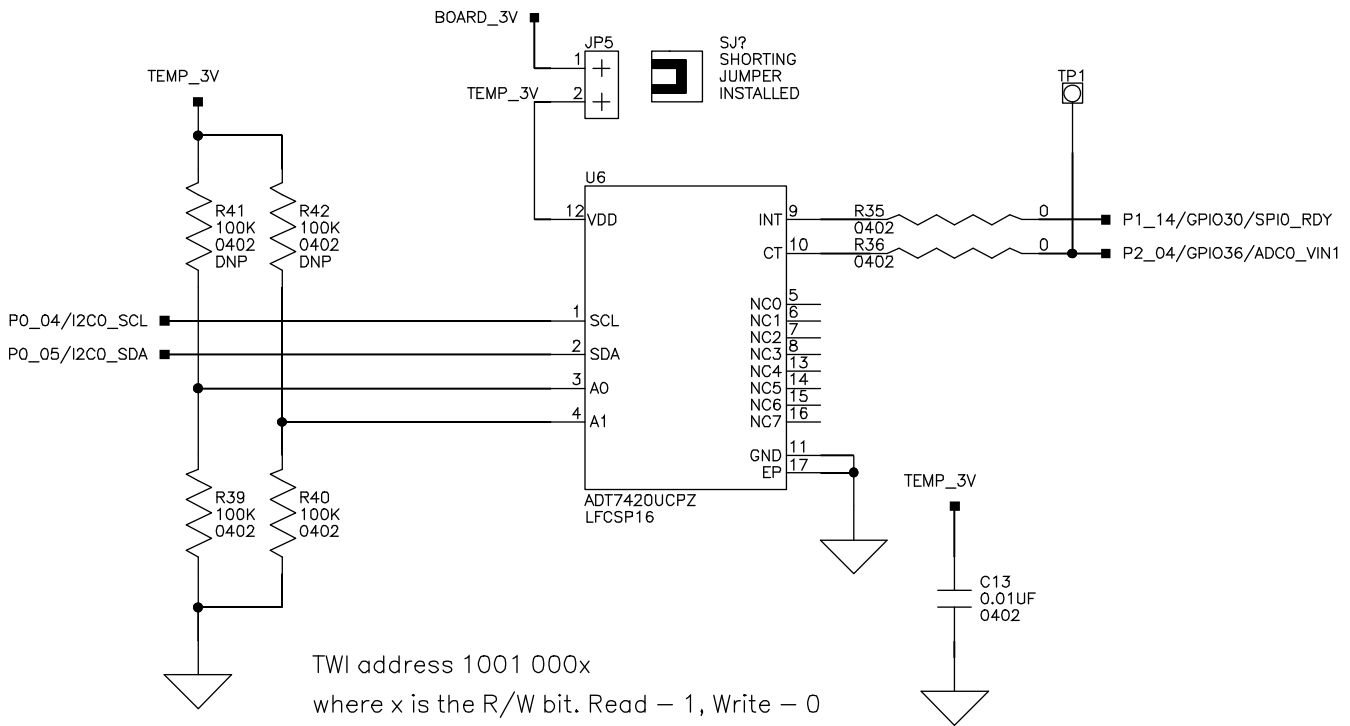

Figure 25. PC Temperature Sensor Circuit Diagram

16130-024

16130-025

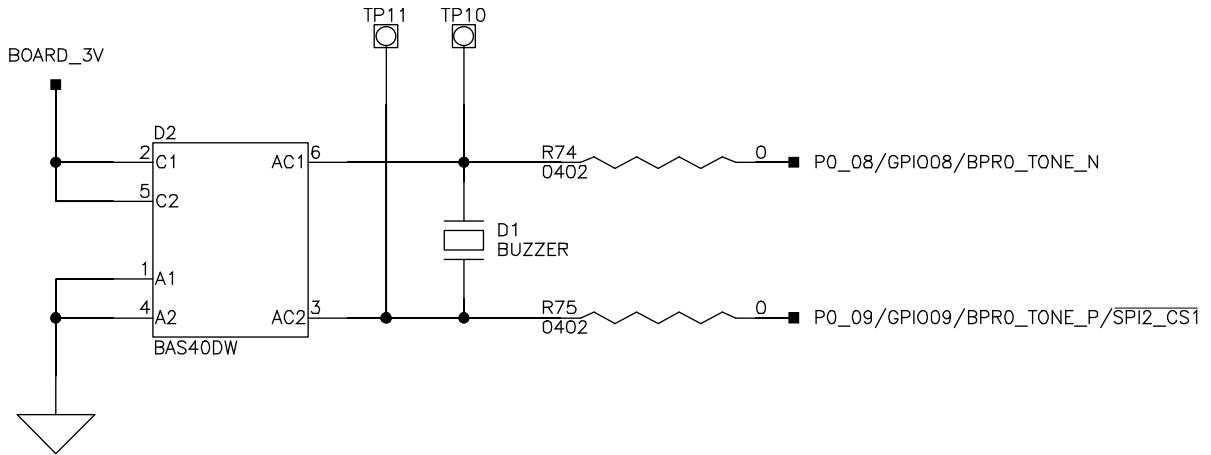

Figure 26. Buzzer Circuit Diagram

16130-026

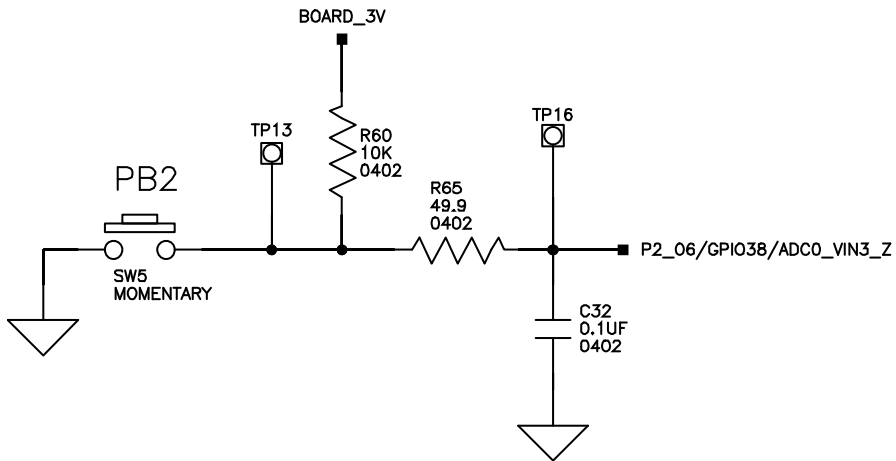
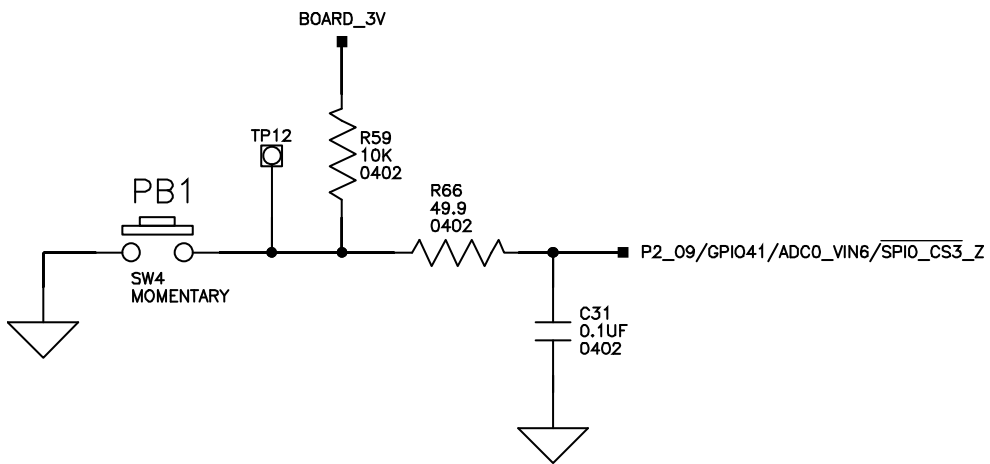

Figure 27. General-Purpose Push-Buttons Circuit

16130-027

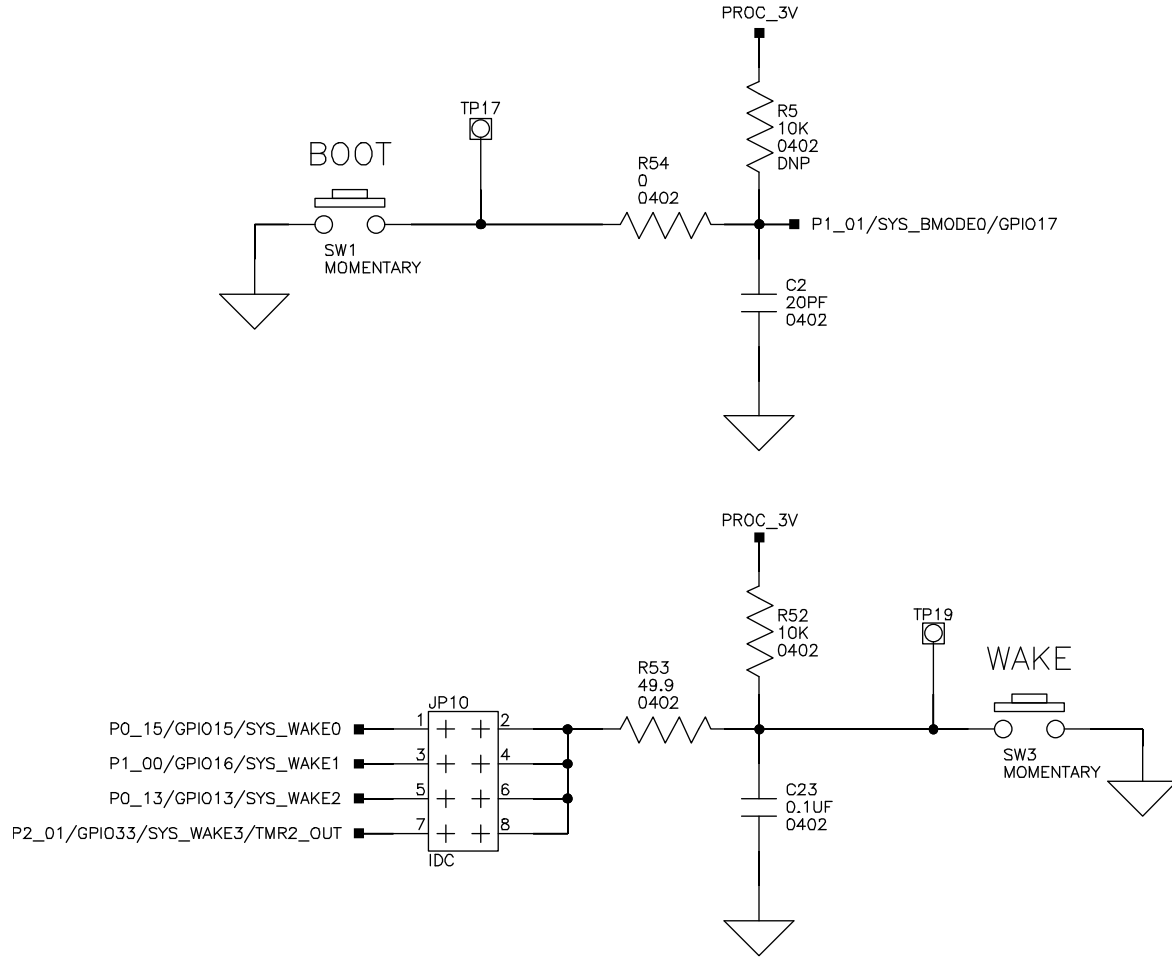

Figure 28. BOOT and WAKE Button Circuit

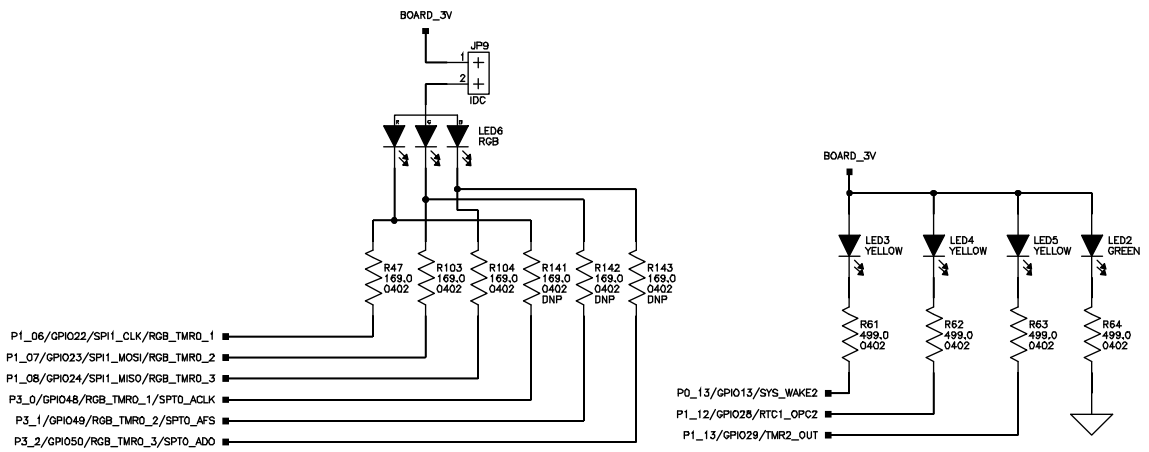

Figure 29. LED Circuit Schematic

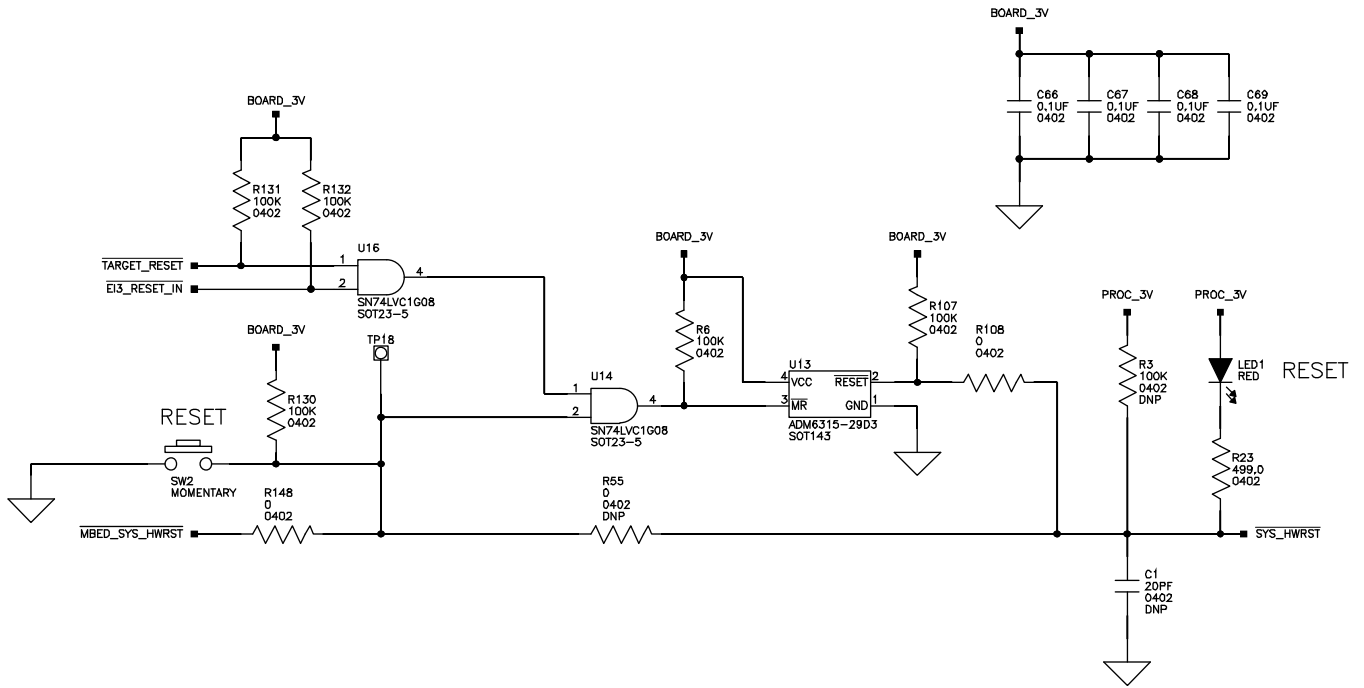

Figure 30. RESET Circuit Schematic

161310-030

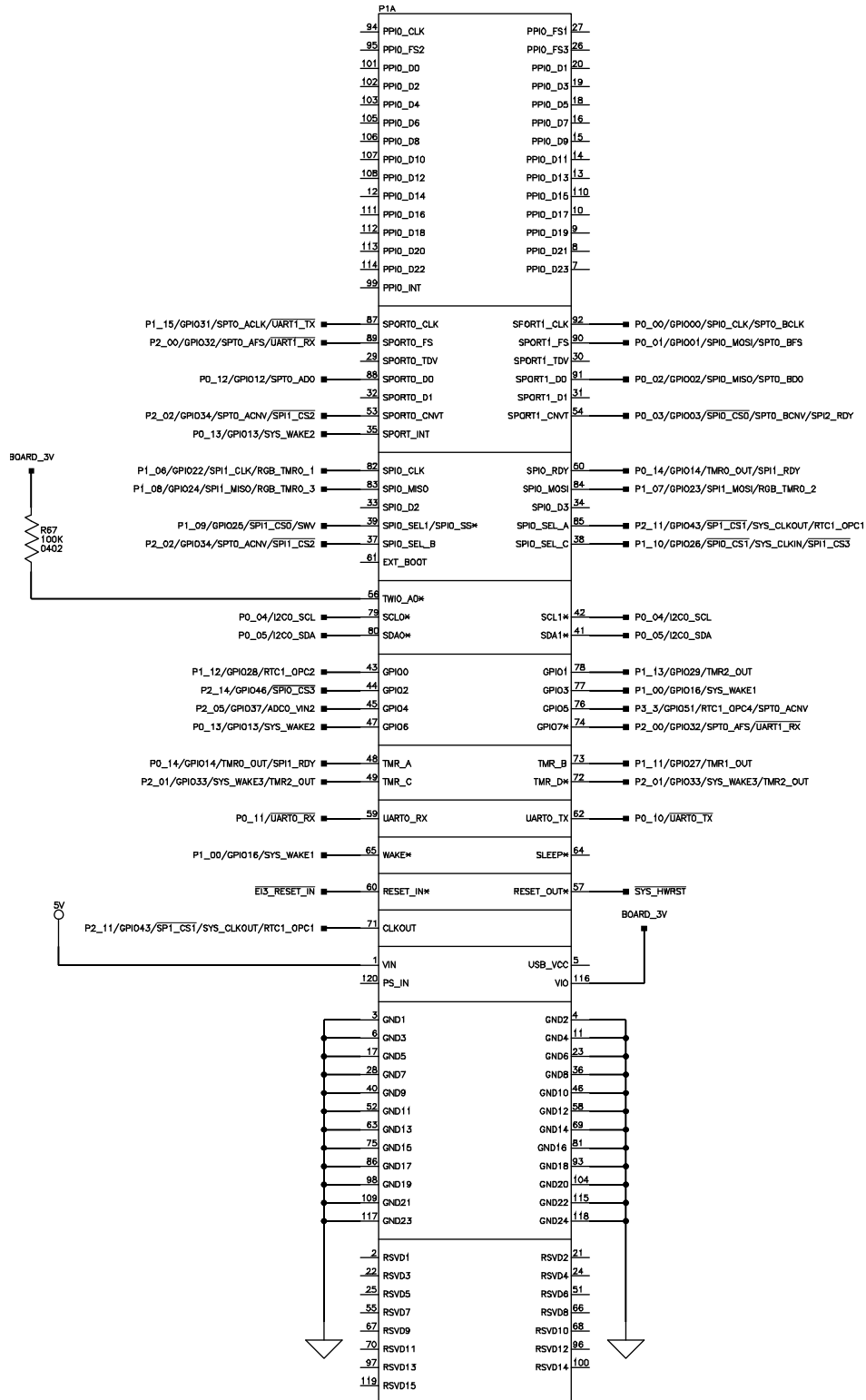

Figure 31. E13 Schematic and Pin Diagram

16130-031

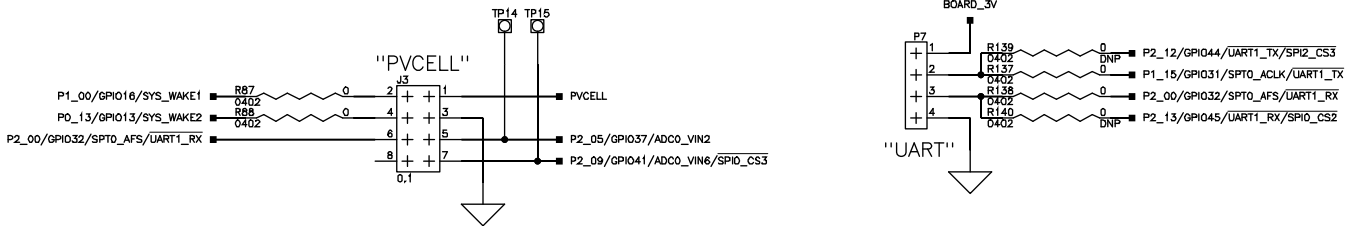

Figure 32. PV Cell Connector and UART (P7) Connector Schematic

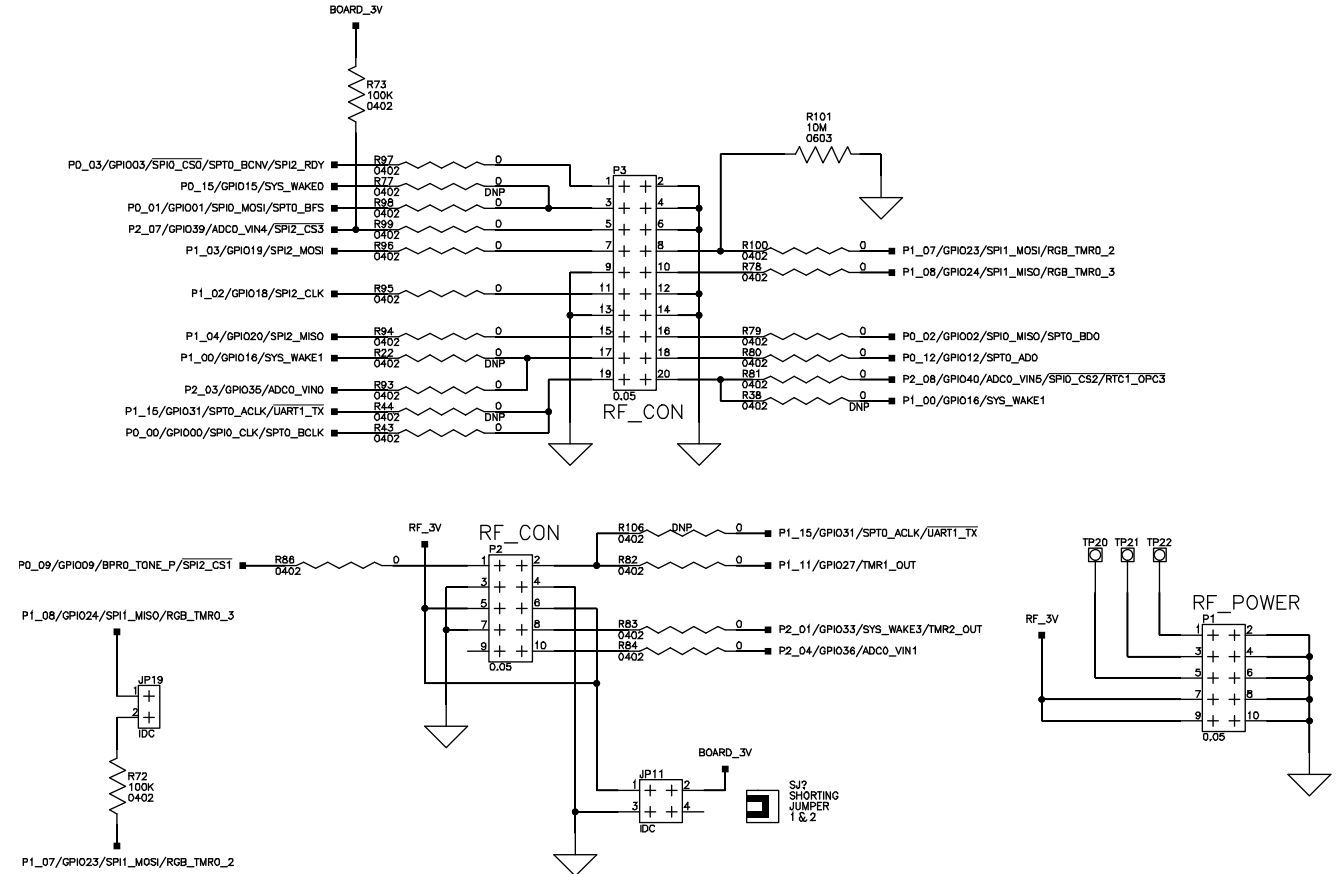

Figure 33. Wireless Transceiver Interface Schematic

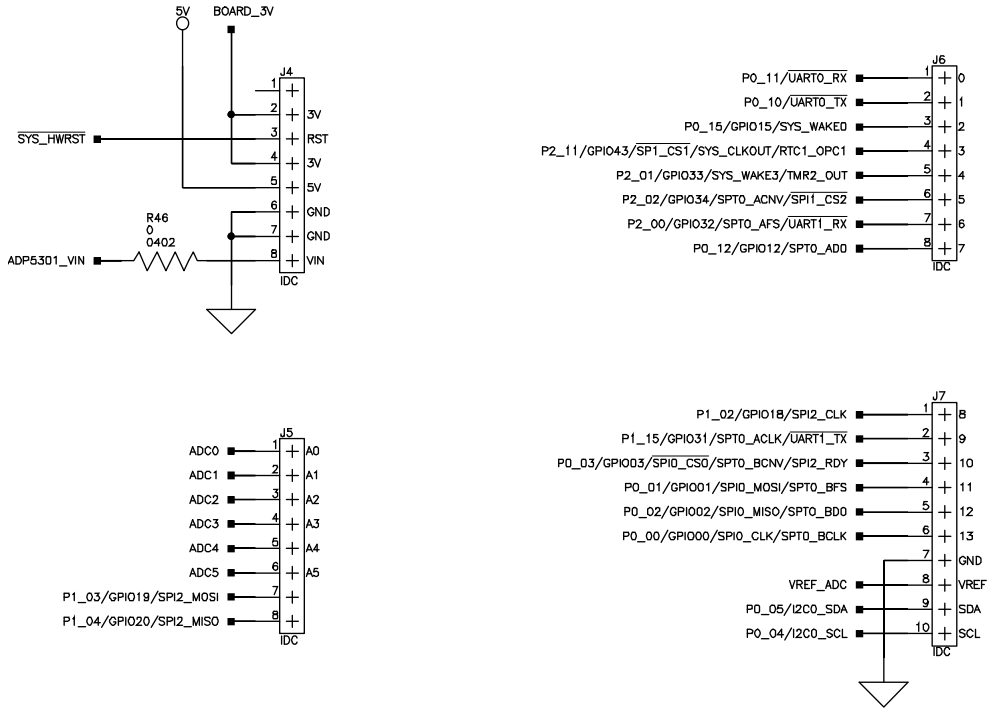

Figure 34. Arduino Headers Schematic

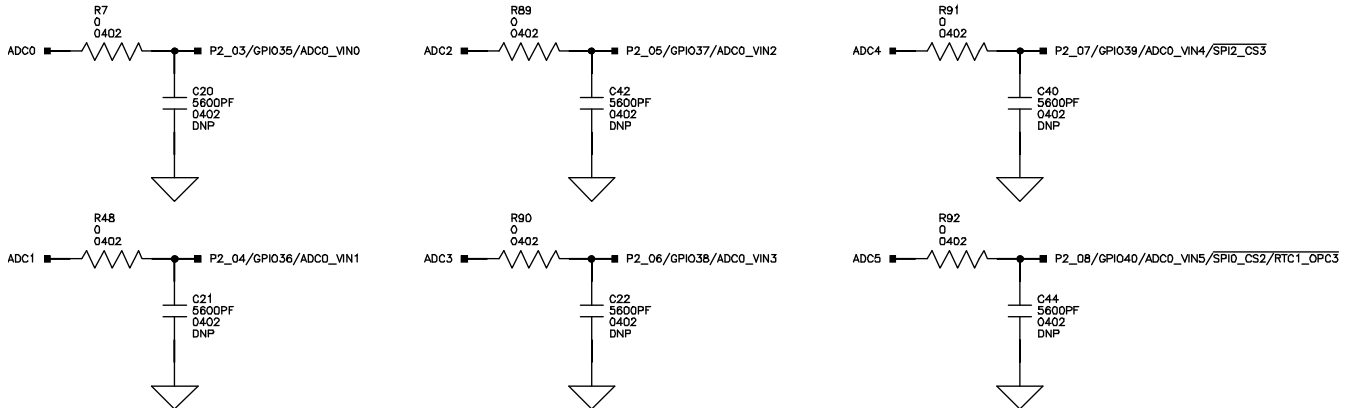

Figure 35. Arduino Analog Interface Schematic

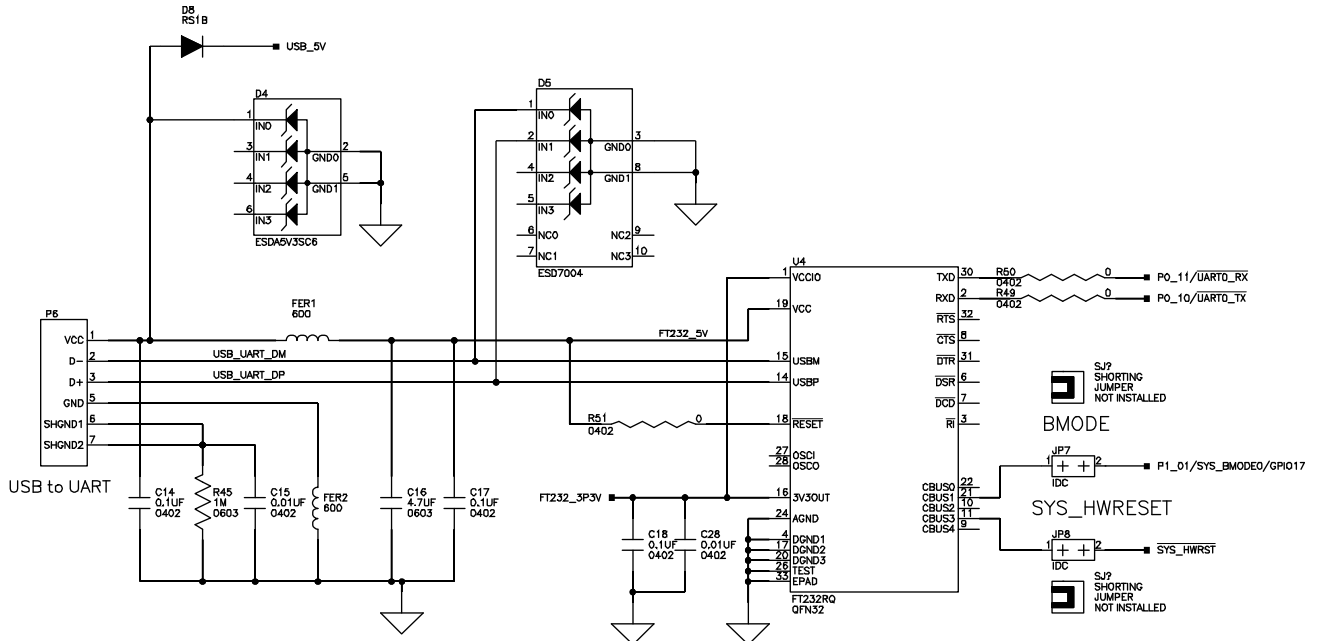

Figure 36. USB to UART Circuit Schematic

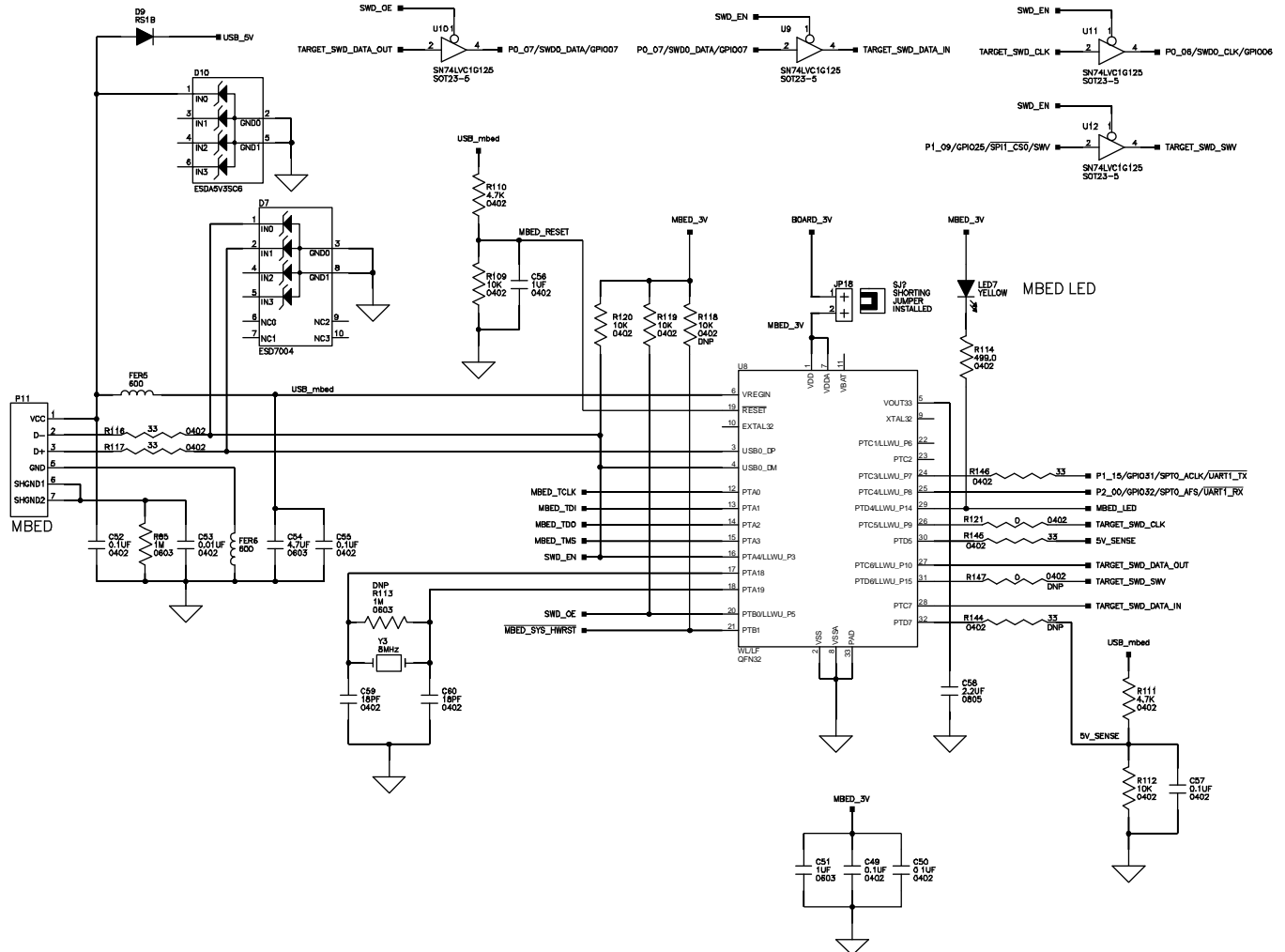

Figure 37. mbed Circuit Schematic

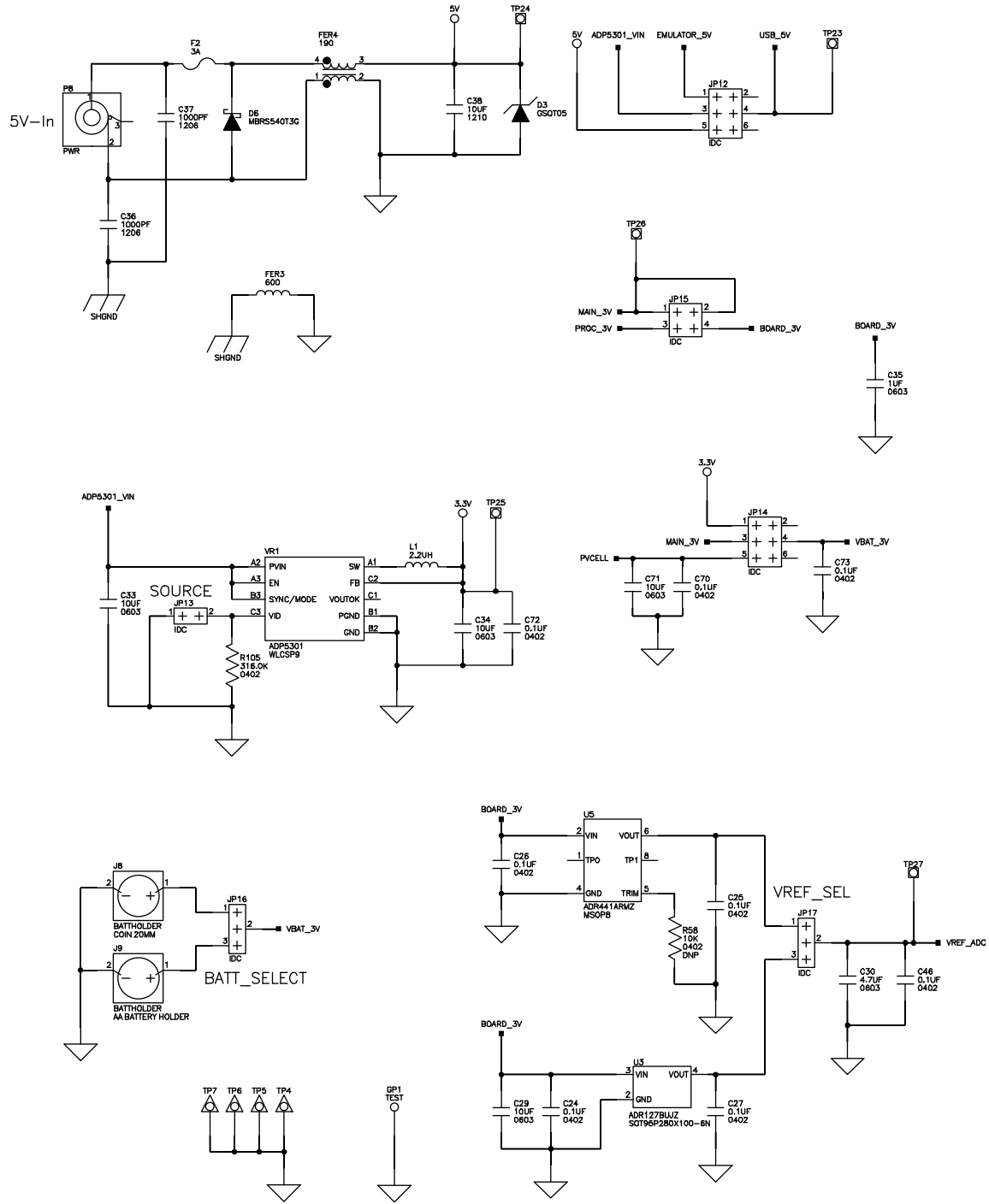

Figure 38. Power Circuit and Connectors Schematic

16130-038

## ORDERING INFORMATION

## BILL OF MATERIALS

Table 9.

Qty	Reference Designator	Description	Manufacturer	Part Number
1	C1	20 pF, 16 V, ±5%, 0402, COG	AVX Corp.	0402YA200JAT2A
5	C11, C13, C15, C28, C53	0.01 μF, 16 V, 10%, 0402, X7R	AVX Corp.	0402YC103KAT2A
13	C12, C19, C49, C50, C61 to C69	0.1 μF, 35 V, 10%, 0402, X7R	TDK	445-6901-2-ND
2	C16, C54	4.7 μF, 6.3 V, 20%, 0603, X5R	AVX Corp.	06036D475MAT2A
3	C2, C7, C48	20 pF, 16 V, ±5%, 0402, COG	AVX Corp.	0402YA200JAT2A
6	C20 to C22, C40, C42, C44	5600 pF, 25 V, X7R, 10%, 0402	Murata	GRM155R71E562KA01D
1	C3	0.47 μF, 16 V, 10%, 0402, JB	TDK	445-10942-2-ND
1	C30	4.7 μF, 10 V, 10%, 0603, X6S	Murata	490-10464-2-ND
1	C35	1 μF, 16 V, 10%, 0603, X5R	KEMET	399-5090-2-ND
2	C36, C37	1000 pF, 50 V, 5%, 1206	AVX Corp.	12065A102JAT2A
1	C38	10 μF, 16 V, 10%, 1210, X5R	AVX Corp.	1210YD106KAT2A
23	C4, C5, C14, C17, C18, C23 to C27, C31, C32, C39, C41, C43, C45, C47, C52, C55, C57, C70, C72, C73	0.1 μF, 10 V, 10%, 0402, X5R	AVX Corp.	0402ZD104KAT2A
1	C46	0.1 μF, 16 V, 10%, 0402, X7R	Taiyo Yuden	587-1451-2-ND
1	C51	1 μF, 50 V, 10%, 0603, X5S	Taiyo Yuden	587-2400-2-ND
1	C58	2.2 μF, 10 V, 10%, 0805, X5R	AVX Corp.	0805ZD225KAT2A
2	C59, C60	18 pF, 50 V, 5%, 0402, NP0	Murata	GRM1555C1H180JA01D
2	C6, C56	1 μF, 6.3 V, 20%, 0402, X5R	Murata	490-1319-2-ND
5	C8, C29, C33, C34, C71	10 μF, 6.3 V, 20%, 0603, X5R	Murata	490-3896-2-ND
2	C9,	8 pF, 16 V, ±0.5 pF, 0402, COG	AVX Corp.	0402YA8R0DAT2A
1	D1	Buzzer, 75 dB, 3 V, 4 kHz	Digikey	490-4683-2-ND
1	D2	200 mA, BAS40DW, SOT-363	Digikey	BAS40DW-04FDITR-ND
1	D3	30 A, GSOT05, SOT23-3	Vishay	GSOT05-E3-08
2	D4, D10	15 kV, ESDA5V3SC6, SOT95P280X145-6N	Digikey	497-6633-1-ND
2	D5, D7	15 kV, ESD7004, DFN50P250X100-10N	ON Semiconductors	ESD7004MUTAG
1	D6	5 A, MBR5540T3G, SMC	ON Semiconductors	MBRS5540T3GOSCT-ND
2	D8, D9	1 A, RS1B, SMB	Diodes Inc.	RS1JB-13-F
1	F2	3 A, resettable, FUS004	TE Connectivity Ltd.	SMD300F-2
5	FER1 to FER3, FER5, FER6	600 Ω at 100 MHz, 500 mA, 1206	Steward	HZ1206B601R-10
1	FER4	190 Ω at 100 MHz, 5 A, FER002	Murata	DLW5BSN191S02
1	GP1	Test loop, LOOP_2838	Keystone Electronics	5016
2	J1, J2	SMC, threaded, AMPHENOL_152119	Amphenol FCI	152119
1	J3	0.1", 8-pin, HARWIN_M20-7880446	Harwin	952-1787-ND
3	J4 to J6	IDC, 8 × 1, IDC8X1	Samtec	SSW-108-01-TM-S
1	J7	IDC, 10 × 1, SAMTEC_SSW-110-01-T-S	Samtec	SSW-110-01-T-S
1	J8	Battery holder, 20 mm, BATT_BS-3	MPD	BS-3
1	J9	Battery holder, AA BATT_2460	Keystone Electronics	2460
1	JP10	IDC, 4 × 2	Sullins Corp.	PEC04DAAN
2	JP11, JP15	IDC, 2 × 2	FCI	68737-404HLF
2	JP12, JP14	IDC, 3 × 2	Berg-FCI	54102-T08-03LF
2	JP16, JP17	IDC, 3 × 1	Samtec	HTSW-103-07-T-S
12	JP1 to JP9, JP13, JP18, JP19	IDC, 2 × 1	Samtec	HTSW-102-07-T-S
1	L1	2.2 μH, 20% PKG	Coilcraft	LPS3015-222MRC

Qty	Reference Designator	Description	Manufacturer	Part Number
1	LED1	Red LED, LED_0603	OSRAM Opto Semiconductors	475-2512-2-ND
1	LED2	Green LED, LED_0603	Lumex	67-1549-2-ND
4	LED3 to LED5, LED7	Yellow LED, LED_0603	OSRAM Opto Semiconductors	475-2793-1-ND
1	LED6	RGB LED_SM1210RGB	Bivar	492-1243-2-ND
2	P1, P2	0.05", 5 × 2, SAMTEC_TFM-105-02-S-DA	Samtec	TFM-105-02-S-D-A
1	P1A	0.6 mm, 120-pin, HIROSE_FX8-120PSV1(91)	HIROSE	FX8-120P-SV1(91)
1	P3	0.05", 10 × 2, SAMTEC_TFM-110-02-S-DA	Samtec	TFM-110-02-S-D-A
2	P4, P12	IDC, 10 × 2, TE_5103308-5	Mouser	571-5103308-5
3	P5,P9,P10	0.05", 10-pin, SAMTEC_SHF-105-01-L-DTH	Samtec	SHF-105-01-L-D-TH-TR
2	P6, P11	USB, 5-pin, CON069	HIROSE	H11589CT-ND
1	P7	IDC, 4 × 1	Berg-FCI	54101-T08-04LF
1	P8	DC power jack, 0.65 mm, CON045	CUI Inc.	CP1-023-ND
63	R1, R2, R4, R7, R11, R12, R14, R15, R17, R31 to R37, R43, R46, R48 to R51, R54, R56, R57, R69 to R71, R74, R75, R78 to R84, R86 to R100, R102, R108, R121, R123, R125, R129, R136 to R138, R148	0 Ω, 1/10 W, 5%, 0402	Panasonic	ERJ-2GE0R00X
1	R101	10 MΩ, 1/10 W, 5%, 0603	Vishay	CRCW060310M0FNEA
1	R105	316.0 kΩ, 1/16 W, 1%, 0402	Vishay	541-316KLTR-ND
2	R110, R111	4.7 kΩ, 1/16 W, 5%, 0402	Vishay	541-4.7KJTR-ND
1	R113	1 MΩ, 1/10 W, 5%, 0603	Vishay	CRCW06031M00JNEA
4	R116, R117, R137, R138	33 Ω, 1/16 W, 5%, 0402	Vishay	CRCW040233R0JNED
2	R13, R124	0 Ω, 1/8 W, 5%, 0805	Vishay	CRCW08050000ZSEA
3	R141 to R143	169.0 Ω, 1/10 W, 1%, 0402	Panasonic	ERJ-2RKF1690X
1	R144	33 Ω, 1/16 W, 5%, 0402	Vishay	CRCW040233R0JNED
1	R16	0 Ω, 1/8 W, 5%, 0805	Vishay	CRCW08050000ZSEA
3	R19 to R21	0.051 Ω, 1/2 W, 1%, 1206	Stackpole Electronics Inc.	CSF 1/2 0.05 1%R
6	R23, R61 to R64, R114	499.0 Ω, 1/10 W, 1%, 0402	Panasonic	ERJ-2RKF4990X
2	R24, R25	2.2 kΩ, 1/10 W, 5%, 0402	Panasonic	ERJ-2GEJ222X
8	R3, R41, R42, R126, R127, R133 to R135	100 kΩ, 1/16 W, 5%, 0402	Vishay	541-100KJTR-ND
2	R45, R85	1 MΩ, 1/10 W, 5%, 0603	Vishay	CRCW06031M00JNEA
3	R47, R103, R104	169.0 Ω, 1/10 W, 1%, 0402	Panasonic	ERJ-2RKF1690X
4	R5, R58, R122, R128	10 kΩ, 1/16 W, 5%, 0402	Vishay	CRCW040210K0FKED
5	R52, R59, R60, R109, R112, R119, R120	10 kΩ, 1/16 W, 5%, 0402	Vishay	CRCW040210K0FKED
3	R53, R65, R66	49.9 Ω, 1/16 W, 1%, 0402	Stackpole Electronics Inc.	RMCF0402FT49R9
18	R6, R26 to R30, R39, R40, R67, R68, R72, R73, R76, R107, R115, R130 to R132	100 kΩ, 1/16 W, 5%, 0402	Vishay	541-100KJTR-ND
2	R8, R18	5 MΩ, 1/20 W, 5%, 0402	Ohmite	HVC0402T5004JET
11	R9, R10, R22, R38, R44, R55, R77, R106, R139, R140, R147	0 Ω, 1/10 W, 5%, 0402	Panasonic	ERJ-2GE0R00X
5	SW1 to SW5	Momentary, SW_ADTSMW64	APEM Components	679-2310-2-ND
1	U1	<a href="#">ADuCM4050BCBZ WLCSP72</a>	Analog Devices	<a href="#">ADuCM4050BCBZ-U1</a>
1	U13	<a href="#">ADM6315-29D3 SOT143</a>	Analog Devices	<a href="#">ADM6315-29D3ARTZR7</a>
2	U14, U16	SN74LVC1G08 SOT23-5	FTDI	SN74LVC1G08DBVE
1	U2	<a href="#">ADXL363BCCZ LFCSP16</a>	Analog Devices	<a href="#">ADXL363BCCZ</a>
1	U3	<a href="#">ADR127BUJZ SOT95P280X100-6N</a>	Analog Devices	<a href="#">ADR127AUJZ-R2</a>
1	U4	FT232RQ QFN32	Winbond	768-1008-1-ND
1	U5	<a href="#">ADR441ARMZ MSOP8</a>	Analog Devices	<a href="#">ADR441ARMZ</a>

Qty	Reference Designator	Description	Manufacturer	Part Number
1	U6	ADT7420UCPZ LFCSP16	Analog Devices	ADT7420UCPZ
1	U7	W25Q32 SO8W	Winbond	W25Q32FVSSIG
1	U8	MK20DX128VFM5	NXP Semiconductors	MK20DX128VFM5
4	U9 to U12	SN74LVC1G125 SOT23-5	TI	74LVC1G125DBVRE4
1	VR1	ADP5301 WLCSP9	Analog Devices	ADP5301ACBZ-2-R7
1	Y1	32.768 kHz, SMD	Abracon LLC	535-12942-2-ND
1	Y2	26 MHz, SMT	Abracon LLC	535-10298-2-ND
1	Y3	8 MHz, SMT, HC49S	TXC Corp.	887-1263-2-ND

I<sup>2</sup>C refers to a communications protocol originally developed by Philips Semiconductors (now NXP Semiconductors).



#### ESD Caution

**ESD (electrostatic discharge) sensitive device.** Charged devices and circuit boards can discharge without detection. Although this product features patented or proprietary protection circuitry, damage may occur on devices subjected to high energy ESD. Therefore, proper ESD precautions should be taken to avoid performance degradation or loss of functionality.

#### Legal Terms and Conditions

By using the evaluation board discussed herein (together with any tools, components documentation or support materials, the "Evaluation Board"), you are agreeing to be bound by the terms and conditions set forth below ("Agreement") unless you have purchased the Evaluation Board, in which case the Analog Devices Standard Terms and Conditions of Sale shall govern. Do not use the Evaluation Board until you have read and agreed to the Agreement. Your use of the Evaluation Board shall signify your acceptance of the Agreement. This Agreement is made by and between you ("Customer") and Analog Devices, Inc. ("ADI"), with its principal place of business at One Technology Way, Norwood, MA 02062, USA. Subject to the terms and conditions of the Agreement, ADI hereby grants to Customer a free, limited, personal, temporary, non-exclusive, non-sublicensable, non-transferable license to use the Evaluation Board FOR EVALUATION PURPOSES ONLY. Customer understands and agrees that the Evaluation Board is provided for the sole and exclusive purpose referenced above, and agrees not to use the Evaluation Board for any other purpose. Furthermore, the license granted is expressly made subject to the following additional limitations: Customer shall not (i) rent, lease, display, sell, transfer, assign, sublicense, or distribute the Evaluation Board; and (ii) permit any Third Party to access the Evaluation Board. As used herein, the term "Third Party" includes any entity other than ADI, Customer, their employees, affiliates and in-house consultants. The Evaluation Board is NOT sold to Customer; all rights not expressly granted herein, including ownership of the Evaluation Board, are reserved by ADI. CONFIDENTIALITY. This Agreement and the Evaluation Board shall all be considered the confidential and proprietary information of ADI. Customer may not disclose or transfer any portion of the Evaluation Board to any other party for any reason. Upon discontinuation of use of the Evaluation Board or termination of this Agreement, Customer agrees to promptly return the Evaluation Board to ADI. ADDITIONAL RESTRICTIONS. Customer may not disassemble, decompile or reverse engineer chips on the Evaluation Board. Customer shall inform ADI of any occurred damages or any modifications or alterations it makes to the Evaluation Board, including but not limited to soldering or any other activity that affects the material content of the Evaluation Board. Modifications to the Evaluation Board must comply with applicable law, including but not limited to the RoHS Directive. TERMINATION. ADI may terminate this Agreement at any time upon giving written notice to Customer. Customer agrees to return to ADI the Evaluation Board at that time. LIMITATION OF LIABILITY. THE EVALUATION BOARD PROVIDED HEREUNDER IS PROVIDED "AS IS" AND ADI MAKES NO WARRANTIES OR REPRESENTATIONS OF ANY KIND WITH RESPECT TO IT. ADI SPECIFICALLY DISCLAIMS ANY REPRESENTATIONS, ENDORSEMENTS, GUARANTEES, OR WARRANTIES, EXPRESS OR IMPLIED, RELATED TO THE EVALUATION BOARD INCLUDING, BUT NOT LIMITED TO, THE IMPLIED WARRANTY OF MERCHANTABILITY, TITLE, FITNESS FOR A PARTICULAR PURPOSE OR NON-INFRINGEMENT OF INTELLECTUAL PROPERTY RIGHTS. IN NO EVENT WILL ADI AND ITS LICENSORS BE LIABLE FOR ANY INCIDENTAL, SPECIAL, INDIRECT, OR CONSEQUENTIAL DAMAGES RESULTING FROM CUSTOMER'S POSSESSION OR USE OF THE EVALUATION BOARD, INCLUDING BUT NOT LIMITED TO LOST PROFITS, DELAY COSTS, LABOR COSTS OR LOSS OF GOODWILL. ADI'S TOTAL LIABILITY FROM ANY AND ALL CAUSES SHALL BE LIMITED TO THE AMOUNT OF ONE HUNDRED US DOLLARS (\$100.00). EXPORT. Customer agrees that it will not directly or indirectly export the Evaluation Board to another country, and that it will comply with all applicable United States federal laws and regulations relating to exports. GOVERNING LAW. This Agreement shall be governed by and construed in accordance with the substantive laws of the Commonwealth of Massachusetts (excluding conflict of law rules). Any legal action regarding this Agreement will be heard in the state or federal courts having jurisdiction in Suffolk County, Massachusetts, and Customer hereby submits to the personal jurisdiction and venue of such courts. The United Nations Convention on Contracts for the International Sale of Goods shall not apply to this Agreement and is expressly disclaimed.

©2018 Analog Devices, Inc. All rights reserved. Trademarks and registered trademarks are the property of their respective owners.  
UG16130-0-5/18(0)



www.analog.com

## Looking for pricing, stock, or lifecycle information?

Click below to explore more details on WIN SOURCE:

- ⊖ [View ADZS-U4050WL-EZKIT on WIN SOURCE](#)
- ⊖ [Analog Devices Inc. Information](#)

## Optimize Your Supply Chain with WIN SOURCE Solutions

- ✓ Global Sourcing Solution
- ✓ Obsolete Management
- ✓ Cost Control Management
- ✓ Shortage Management
- ✓ Alternative Solution
- ✓ Excess Inventory Management