



**THE DATASHEET OF
AD9397KSTZ-150**



FEATURES

DVI interface

- Supports high-bandwidth digital content protection
- RGB to YCbCr 2-way color conversion
- 1.8 V/3.3 V power supply
- 100-lead, Pb-free LQFP
- RGB and YCbCr output formats

Digital video interface

- DVI 1.0
- 150 MHz DVI receiver
- Supports high-bandwidth digital content protection (HDCP 1.1)

APPLICATIONS

- Advanced TVs
- HDTVs
- Projectors
- LCD monitors

FUNCTIONAL BLOCK DIAGRAM

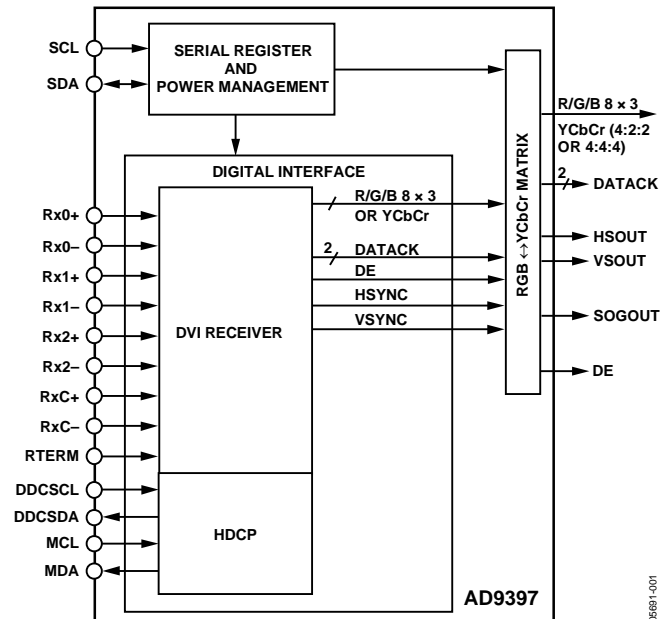

Figure 1.

GENERAL DESCRIPTION

The AD9397 is a digital visual interface (DVI) receiver integrated on a single chip. Also included is support for high bandwidth digital content protection (HDCP) with internal key storage.

The AD9397 contains a DVI 1.0-compatible receiver and supports all HDTV formats (up to 1080p and 720p) and display resolutions up to SXGA (1280 × 1024 @ 80 Hz). The receiver features an intrapair skew tolerance of up to one full clock cycle. With the inclusion of HDCP, displays can receive encrypted

video content. The AD9397 allows for authentication of a video receiver, decryption of encoded data at the receiver, and renewability of that authentication during transmission as specified by the HDCP 1.1 protocol.

Fabricated in an advanced CMOS process, the AD9397 is provided in a space-saving, 100-lead, surface-mount, Pb-free plastic LQFP and is specified over the 0°C to 70°C temperature range.

Rev. 0

Information furnished by Analog Devices is believed to be accurate and reliable. However, no responsibility is assumed by Analog Devices for its use, nor for any infringements of patents or other rights of third parties that may result from its use. Specifications subject to change without notice. No license is granted by implication or otherwise under any patent or patent rights of Analog Devices. Trademarks and registered trademarks are the property of their respective owners.

TABLE OF CONTENTS

Features	1	DVI Receiver	11
Applications	1	DE Generator	11
Functional Block Diagram	1	4:4:4 to 4:2:2 Filter	12
General Description	1	Output Data Formats	12
Revision History	2	2-Wire Serial Register Map	13
Specifications	3	2-Wire Serial Control Register Details	18
Electrical Characteristics	3	Chip Identification	18
Digital Interface Electrical Characteristics	4	BT656 Generation	20
Absolute Maximum Ratings	6	Macrovision	21
Explanation of Test Levels	6	Color Space Conversion	21
ESD Caution	6	2-Wire Serial Control Port	23
Pin Configuration and Function Descriptions	7	Data Transfer via Serial Interface	23
Design Guide	10	Serial Interface Read/Write Examples	24
General Description	10	PCB Layout Recommendations	25
Digital Inputs	10	Power Supply Bypassing	25
Serial Control Port	10	Outputs (Both Data and Clocks)	25
Output Signal Handling	10	Digital Inputs	25
Power Management	10	Color Space Converter (CSC) Common Settings	26
Timing	11	Outline Dimensions	28
HSYNC Timing	11	Ordering Guide	28
VSYNC Filter and Odd/Even Fields	11		

REVISION HISTORY**10/05—Revision 0: Initial Version**

SPECIFICATIONS

ELECTRICAL CHARACTERISTICS

V_{DD} , $V_D = 3.3$ V, $DV_{DD} = PV_{DD} = 1.8$ V, ADC clock = maximum.

Table 1.

Parameter	Temp	Test Level	AD9397KSTZ-100			AD9397KSTZ-150			Unit
			Min	Typ	Max	Min	Typ	Max	
RESOLUTION				8			8		Bits
Data-to-Clock Skew	Full	IV	-0.5		+2.0	-0.5		+2.0	ns
Serial Port Timing									
t_{BUFF}	Full	VI	4.7			4.7			μ s
t_{STAH}	Full	VI	4.0			4.0			μ s
t_{DHO}	Full	VI	0			0			μ s
t_{DAL}	Full	VI	4.7			4.7			μ s
t_{DAH}	Full	VI	4.0			4.0			μ s
t_{DSU}	Full	VI	250			250			ns
t_{STASU}	Full	VI	4.7			4.7			μ s
t_{STOSU}	Full	VI	4.0			4.0			μ s
DIGITAL INPUTS (5 V TOLERANT)									
Input Voltage, High (V_{IH})	Full	VI	2.6			2.6			V
Input Voltage, Low (V_{IL})	Full	VI			0.8			0.8	V
Input Current, High (I_{IH})	Full	V		-82			-82		μ A
Input Current, Low (I_{IL})	Full	V		82			82		μ A
Input Capacitance	25°C	V		3			3		pF
DIGITAL OUTPUTS									
Output Voltage, High (V_{OH})	Full	VI	$V_{DD} - 0.1$			$V_{DD} - 0.1$			V
Output Voltage, Low (V_{OL})	Full	VI			0.4			0.4	V
Duty Cycle, DATAACK	Full	V	45	50	55	45	50	55	%
Output Coding				Binary			Binary		
POWER SUPPLY									
V_D Supply Voltage	Full	IV	3.15	3.3	3.47	3.15	3.3	3.47	V
DV_{DD} Supply Voltage	Full	IV	1.7	1.8	1.9	1.7	1.8	1.9	V
V_{DD} Supply Voltage	Full	IV	1.7	3.3	3.47	1.7	3.3	3.47	V
PV_{DD} Supply Voltage	Full	IV	1.7	1.8	1.9	1.7	1.8	1.9	V
I_D Supply Current (V_D)	25°C	VI		260	300			330	mA
I_{DVDD} Supply Current (DV_{DD})	25°C	VI		45	60			85	mA
I_{DD} Supply Current (V_{DD}) ¹	25°C	VI		37	100 ²			130 ²	mA
I_{PVDD} Supply Current (PV_{DD})	25°C	VI		10	15			20	mA
Total Power	Full	VI		1.1	1.4		1.15	1.4	W
Power-Down Dissipation	Full	VI		130			130		mW
THERMAL CHARACTERISTICS									
θ_{JA} Junction to Ambient		V		35			35		°C/W

¹ DATAACK load = 15 pF, data load = 5 pF.

² Specified current and power values with a worst-case pattern (on/off).

AD9397

DIGITAL INTERFACE ELECTRICAL CHARACTERISTICS

$V_{DD} = V_D = 3.3$ V, $DV_{DD} = PV_{DD} = 1.8$ V, ADC clock = maximum.

Table 2.

Parameter	Test Level	Conditions	AD9397KSTZ-100			AD9397KSTZ-150			Unit
			Min	Typ	Max	Min	Typ	Max	
RESOLUTION				8			8		Bit
DC DIGITAL I/O SPECIFICATIONS									
High Level Input Voltage, (V_{IH})	VI		2.5			2.5			V
Low Level Input Voltage, (V_{IL})	VI				0.8			0.8	V
High Level Output Voltage, (V_{OH})	VI		$V_{DD} - 0.1$						V
Low Level Output Voltage, (V_{OL})	VI		$V_{DD} - 0.1$		0.1			0.1	V
DC SPECIFICATIONS									
Output High Level	IV	Output drive = high		36			36		mA
I_{OHD} , ($V_{OUT} = V_{OH}$)	IV	Output drive = low		24			24		mA
Output Low Level	IV	Output drive = high		12			12		mA
I_{OLD} , ($V_{OUT} = V_{OL}$)	IV	Output drive = low		8			8		mA
DATAACK High Level	IV	Output drive = high		40			40		mA
V_{OHC} , ($V_{OUT} = V_{OH}$)	IV	Output drive = low		20			20		mA
DATAACK Low Level	IV	Output drive = high		30			30		mA
V_{OLC} , ($V_{OUT} = V_{OL}$)	IV	Output drive = low		15			15		mA
Differential Input Voltage, Single-Ended Amplitude	IV		75		700	75		700	mV
POWER SUPPLY									
V_D Supply Voltage	IV		3.15	3.3	3.47	3.15	3.3	3.47	V
V_{DD} Supply Voltage	IV		1.7	3.3	347	1.7	3.3	347	V
DV_{DD} Supply Voltage	IV		1.7	1.8	1.9	1.7	1.8	1.9	V
PV_{DD} Supply Voltage	IV		1.7	1.8	1.9	1.7	1.8	1.9	V
I_{VD} Supply Current (Typical Pattern) ¹	V			80	100		80	110	mA
I_{VDD} Supply Current (Typical Pattern) ²	V			40	100 ³		55	175 ³	mA
I_{DVDD} Supply Current (Typical Pattern) ^{1, 4}	V			88	110		110	145	mA
I_{PVDD} Supply Current (Typical Pattern) ¹	V			26	35		30	40	mA
Power-Down Supply Current (I_{PD})	VI			130			130		mA

Parameter	Test Level	Conditions	AD9397KSTZ-100			AD9397KSTZ-150			Unit
			Min	Typ	Max	Min	Typ	Max	
AC SPECIFICATIONS									
Intrapair (+ to -) Differential Input Skew (T _{DPS})	IV							360	ps
Channel to Channel Differential Input Skew (T _{CCS})	IV							6	Clock Period
Low-to-High Transition Time for Data and Controls (D _{LHT})	IV	Output drive = high; C _L = 10 pF						900	ps
	IV	Output drive = low; C _L = 5 pF						1300	ps
Low-to-High Transition Time for DATAACK (D _{LHT})	IV	Output drive = high; C _L = 10 pF						650	ps
	IV	Output drive = low; C _L = 5 pF						1200	ps
High-to-Low Transition Time for Data and Controls (D _{HLT})	IV	Output drive = high; C _L = 10 pF						850	ps
	IV	Output drive = low; C _L = 5 pF						1250	ps
High-to-Low Transition Time for DATAACK (D _{HLT})	IV	Output drive = high; C _L = 10 pF						800	ps
	IV	Output drive = low; C _L = 5 pF						1200	ps
Clock to Data Skew ⁵ (T _{SKEW})	IV		-0.5		+2.0	-0.5		+2.0	ns
Duty Cycle, DATAACK ⁵	IV		45	50				55	%
DATAACK Frequency (F _{CIP})	VI		20					150	MHz

¹ The typical pattern contains a gray scale area, output drive = high. Worst-case pattern is alternating black and white pixels.

² The typical pattern contains a gray scale area, output drive = high.

³ Specified current and power values with a worst-case pattern (on/off).

⁴ DATAACK load = 10 pF, data load = 5 pF.

⁵ Drive strength = high.

ABSOLUTE MAXIMUM RATINGS

Table 3.

Parameter	Rating
V_D	3.6 V
V_{DD}	3.6 V
DV_{DD}	1.98 V
PV_{DD}	1.98 V
Analog Inputs	V_D to 0.0 V
Digital Inputs	5 V to 0.0 V
Digital Output Current	20 mA
Operating Temperature Range	-25°C to +85°C
Storage Temperature Range	-65°C to +150°C
Maximum Junction Temperature	150°C
Maximum Case Temperature	150°C

Stresses above those listed under Absolute Maximum Ratings may cause permanent damage to the device. This is a stress rating only; functional operation of the device at these or any other conditions above those indicated in the operational section of this specification is not implied. Exposure to absolute maximum rating conditions for extended periods may affect device reliability.

EXPLANATION OF TEST LEVELS

Table 4.

Level	Test
I	100% production tested.
II	100% production tested at 25°C and sample tested at specified temperatures.
III	Sample tested only.
IV	Parameter is guaranteed by design and characterization testing.
V	Parameter is a typical value only.
VI	100% production tested at 25°C; guaranteed by design and characterization testing.

ESD CAUTION

ESD (electrostatic discharge) sensitive device. Electrostatic charges as high as 4000 V readily accumulate on the human body and test equipment and can discharge without detection. Although this product features proprietary ESD protection circuitry, permanent damage may occur on devices subjected to high energy electrostatic discharges. Therefore, proper ESD precautions are recommended to avoid performance degradation or loss of functionality.



AD9397

Pin Type	Pin No.	Mnemonic	Function	Value
POWER SUPPLY	80, 76, 72, 67, 45, 33	V _D	Analog Power Supply and DVI Terminators	3.3 V
	100, 90, 10	V _{DD}	Output Power Supply	1.8 V to 3.3 V
	59, 56, 54	PV _{DD}	PLL Power Supply	1.8 V
	48, 32, 30	DV _{DD}	Digital Logic Power Supply	1.8 V
		GND	Ground	0 V
CONTROL	83	SDA	Serial Port Data I/O	3.3 V CMOS
	82	SCL	Serial Port Data Clock	3.3 V CMOS
HDCP	49	DDCSCL	HDCP Slave Serial Port Data Clock	3.3 V CMOS
	50	DDCSDA	HDCP Slave Serial Port Data I/O	3.3 V CMOS
	51	MCL	HDCP Master Serial Port Data Clock	3.3 V CMOS
	52	MDA	HDCP Master Serial Port Data I/O	3.3 V CMOS
DATA ENABLE	88	DE	Data Enable	3.3 V CMOS
RTERM	46	RTERM	Sets Internal Termination Resistance	500 Ω

Table 6. Pin Function Descriptions

Pin	Description
INPUTS	
Rx0+	Digital Input Channel 0 True.
Rx0-	Digital Input Channel 0 Complement.
Rx1+	Digital Input Channel 1 True.
Rx1-	Digital Input Channel 1 Complement.
Rx2+	Digital Input Channel 2 True.
Rx2-	Digital input Channel 2 Complement.
	These six pins receive three pairs of transition minimized differential signaling (TMDS) pixel data (at 10× the pixel rate) from a digital graphics transmitter.
RxC+	Digital Data Clock True.
RxC-	Digital Data Clock Complement.
	This clock pair receives a TMDS clock at 1× pixel data rate.
PWRDN	Power-Down Control/Three-State Control.
	The function of this pin is programmable via Register 0x26 [2:1].
RTERM	RTERM is the termination resistor used to drive the AD9397 internally to a precise 50 Ω termination for TMDS lines. This should be a 500 Ω 1% tolerance resistor.
OUTPUTS	
HSOUT	Horizontal Sync Output. A reconstructed and phase-aligned version of the HSYNC input. Both the polarity and duration of this output can be programmed via serial bus registers. By maintaining alignment with DATAACK and Data, data timing with respect to horizontal sync can always be determined.
VSOUT	Vertical Sync Output. The separated VSYNC from a composite signal or a direct pass through of the VSYNC signal. The polarity of this output can be controlled via the serial bus bit (Register 0x24 [6]).
FIELD	Odd/Even Field Bit for Interlaced Video. This output identifies whether the current field (in an interlaced signal) is odd or even. The polarity of this signal is programmable via Register 0x24[4].
DE	Data Enable that defines valid video. Can be received in the signal or generated by the AD9397.
CTL(3-0)	Control 3, Control 2, Control 1, and Control 0 are output from the DVI stream. Refer to the DVI 1.0 specification for explanation.
SERIAL PORT	
SDA	Serial Port Data I/O for Programming AD9397 Registers—I ² C Address is 0x98.
SCL	Serial Port Data Clock for Programming AD9397 Registers.
DDCSDA	Serial Port Data I/O for HDCP Communications to Transmitter—I ² C Address is 0x74 or 0x76.
DDCSCL	Serial Port Data Clock for HDCP Communications to Transmitter.
MDA	Serial Port Data I/O to EEPROM with HDCP Keys—I ² C Address is 0xA0.
MCL	Serial Port Data Clock to EEPROM with HDCP Keys.

Pin	Description
DATA OUTPUTS RED [7:0] GREEN [7:0] BLUE [7:0]	Data Output, Red Channel. Data Output, Green Channel. Data Output, Blue Channel. The main data outputs. Bit 7 is the MSB. The delay from pixel sampling time to output is fixed, but is different if the color space converter is used. When the sampling time is changed by adjusting the phase register, the output timing is shifted as well. The DATAACK and HSOUT outputs are also moved, so the timing relationship among the signals is maintained.
DATA CLOCK OUTPUT DATAACK	Data Clock Output. This is the main clock output signal used to strobe the output data and HSOUT into external logic. Four possible output clocks can be selected with Register 0x25 [7:6]. These are related to the pixel clock (1/2x pixel clock, 1x pixel clock, 2x frequency pixel clock, and a 90° phase shifted pixel clock). They are produced either by the internal PLL clock generator or EXTCLK and are synchronous with the pixel sampling clock. The polarity of DATAACK can also be inverted via Register 0x24 [0]. The sampling time of the internal pixel clock can be changed by adjusting the phase register. When this is changed, the pixel-related DATAACK timing is shifted as well. The DATA, DATAACK, and HSOUT outputs are all moved, so the timing relationship among the signals is maintained.
POWER SUPPLY ¹ V _D (3.3 V) V _{DD} (1.8 V to 3.3 V) PV _{DD} (1.8 V) DV _{DD} (1.8 V)	Analog Power Supply. These pins supply power to the ADCs and terminators. They should be as quiet and filtered as possible. Digital Output Power Supply. A large number of output pins (up to 27) switching at high speed (up to 150 MHz) generates many power supply transients (noise). These supply pins are identified separately from the V _D pins, so output noise transferred into the sensitive analog circuitry can be minimized. If the AD9397 is interfacing with lower voltage logic, V _{DD} may be connected to a lower supply voltage (as low as 1.8 V) for compatibility. Clock Generator Power Supply. The most sensitive portion of the AD9397 is the clock generation circuitry. These pins provide power to the clock PLL and help the user design for optimal performance. The designer should provide quiet, noise-free power to these pins. Digital Input Power Supply. This supplies power to the digital logic.
GND	Ground. The ground return for all circuitry on chip. It is recommended that the AD9397 be assembled on a single solid ground plane, with careful attention to ground current paths.

¹ The supplies should be sequenced such that V_D and V_{DD} are never less than 300 mV below DV_{DD}. At no time should DV_{DD} be more than 300 mV greater than V_D or V_{DD}.

DESIGN GUIDE

GENERAL DESCRIPTION

The AD9397 is a fully integrated digital visual interface (DVI) for receiving RGB or YUV signals for display on flat panel monitors, projectors or PDPs. This interface is capable of decoding HDCP-encrypted signals through connection to an external EEPROM. The circuit is ideal for providing an interface for HDTV monitors or as the front-end to high performance video scan converters.

Implemented in a high performance CMOS process, the interface can capture signals with pixel rates of up to 150 MHz.

The AD9397 includes all necessary input buffering, signal dc restoration (clamping), offset and gain (brightness and contrast) adjustment, pixel clock generation, sampling phase control, and output data formatting. Included in the output formatting is a color space converter (CSC), which accommodates any input color space and can output any color space. All controls are programmable via a 2-wire serial interface. Full integration of these sensitive analog functions makes system design straightforward and less sensitive to the physical and electrical environments.

DIGITAL INPUTS

All digital control inputs (HSYNC, VSYNC, I²C) on the AD9397 operate to 3.3 V CMOS levels. In addition, all digital inputs except the TMDS (DVI) inputs are 5 V tolerant. (Applying 5 V to them does not cause any damage.) TMDS inputs (Rx0+/Rx0-, Rx1+/Rx1-, Rx2+/Rx2-, and RxC+/RxC-) must maintain a 100 Ω differential impedance (through proper PCB layout) from the connector to the input where they are internally terminated (50 Ω to 3.3 V). If additional ESD protection is desired, use of a California Micro Devices (CMD) CM1213 (among others) series low capacitance ESD protection offers 8 kV of protection to the HDMI TMDS lines.

SERIAL CONTROL PORT

The serial control port is designed for 3.3 V logic. However, it is tolerant of 5 V logic signals.

OUTPUT SIGNAL HANDLING

The digital outputs operate from 1.8 V to 3.3 V (V_{DD}).

POWER MANAGEMENT

The AD9397 uses the activity detect circuits, the active interface bits in the serial bus, the active interface override bits, the power-down bit, and the power-down pin to determine the correct power state. There are four power states: full-power, seek mode, auto power-down, and power-down. Table 7 summarizes how the AD9397 determines which power mode to be in and which circuitry is powered on/off in each of these modes. The power-down command has priority and then the automatic circuitry. The power-down pin (Pin 81—polarity set by Register 0x26[3]) can drive the chip into four power-down options. Bit 2 and Bit 1 of Register 0x26 control these four options. Bit 0 controls whether the chip is powered down or the outputs are placed in high impedance mode (with the exception of SOG). Bit 7 to Bit 4 of Register 0x26 control whether the outputs, SOG, Sony Philips digital interface (S/PDIF), or Inter-IC sound bus (I²S or IIS) outputs are in high impedance mode or not. See the 2-Wire Serial Control Register Detail section for more details.

Table 7. Power-Down Mode Descriptions

Mode	Inputs			Power-On or Comments
	Power-Down ¹	Sync Detect ²	Auto PD Enable ³	
Full Power	1	1	X	Everything
Seek Mode	1	0	0	Everything
Seek Mode	1	0	1	Serial bus, sync activity detect, SOG, band gap reference
Power-Down	0	X		Serial bus, sync activity detect, SOG, band gap reference

¹ Power-down is controlled via Bit 0 in Serial Bus Register 0x26.

² Sync detect is determined by OR'ing Bit 7 to Bit 2 in Serial Bus Register 0x15.

³ Auto power-down is controlled via Bit 7 in Serial Bus Register 0x27.

TIMING

The output data clock signal is created so that its rising edge always occurs between data transitions and can be used to latch the output data externally.

Figure 3 shows the timing operation of the AD9397.

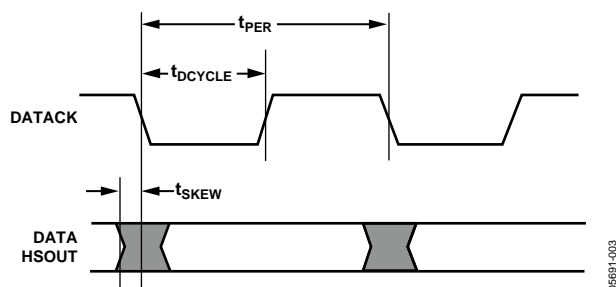

Figure 3. Output Timing

HSYNC TIMING

Horizontal sync (HSYNC) is processed in the AD9397 to eliminate ambiguity in the timing of the leading edge with respect to the phase-delayed pixel clock and data.

The HSYNC input is used as a reference to generate the pixel sampling clock. The sampling phase can be adjusted, with respect to HSYNC, through a full 360° in 32 steps via the phase adjust register (to optimize the pixel sampling time). Display systems use HSYNC to align memory and display write cycles, so it is important to have a stable timing relationship between the HSYNC output (HSOUT) and data clock (DATAACK).

VSYNC FILTER AND ODD/EVEN FIELDS

The VSYNC filter is used to eliminate spurious VSYNCs, maintain a consistent timing relationship between the VSYNC and HSYNC output signals, and generate the odd/even field output.

The filter works by examining the placement of VSYNC with respect to HSYNC and, if necessary, slightly shifting it in time at the VSOUT output. The goal is to keep the VSYNC and HSYNC leading edges from switching at the same time, eliminating confusion as to when the first line of a frame occurs. Enabling the VSYNC filter is done with Register 0x21 [5]. Use of the VSYNC filter is recommended for all cases, including interlaced video, and is required when using the HSYNC per VSYNC counter. Figure 4 and Figure 5 illustrate even/odd field determination in two situations.

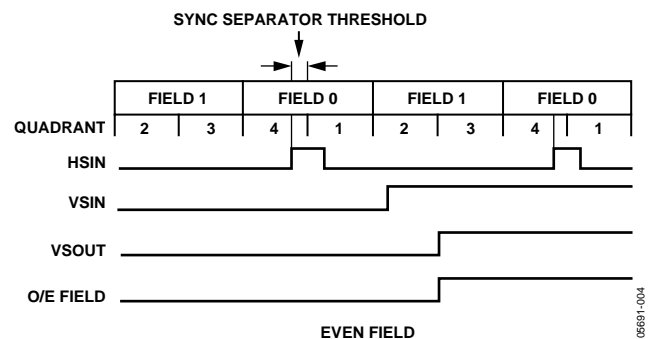

Figure 4. VSYNC Filter

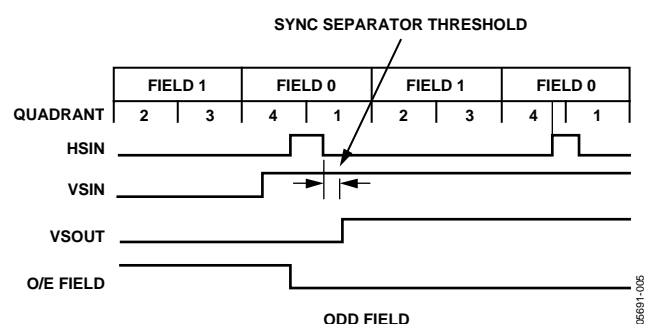

Figure 5. VSYNC Filter—Odd/Even

DVI RECEIVER

The DVI receiver section of the AD9397 allows the reception of a digital video stream compatible with DVI 1.0. Embedded in this data stream are HSYNCs, VSYNCs, and display enable (DE) signals. DVI restricts the received format to RGB, but the inclusion of a programmable color space converter (CSC) allows the output to be tailored to any format necessary. With this, the scaler following the AD9397 can specify that it always wishes to receive a particular format—for instance, 4:2:2 YCrCb—regardless of the transmitted mode. If RGB is sent, the CSC can easily convert that to 4:2:2 YCrCb while relieving the scaler of this task.

DE GENERATOR

The AD9397 has an onboard generator for DE, for start of active video (SAV), and for end of active video (EAV), all of which are necessary for describing the complete data stream for a BT656-compatible output. In addition to this particular output, it is possible to generate the DE for cases in which a scaler is not used. This signal alerts the following circuitry as to which are displayable video pixels.

4:4:4 TO 4:2:2 FILTER

The AD9397 contains a filter that allows it to convert a signal from YCrCb 4:4:4 to YCrCb 4:2:2 while maintaining the maximum accuracy and fidelity of the original signal.

Input Color Space to Output Color Space

The AD9397 can support a wide variety of output formats, such as:

- RGB 24-bit
- 4:4:4 YCrCb 8-bit
- 4:2:2 YCrCb 8-bit, 10-bit, and 12-bit
- Dual 4:2:2 YCrCb 8-bit

Color Space Conversion (CSC) Matrix

The CSC matrix in the AD9397 consists of three identical processing channels. In each channel, three input values are multiplied by three separate coefficients. Also included are an offset value for each row of the matrix and a scaling multiple for all values. Each value has a 13-bit, twos complement resolution to ensure the signal integrity is maintained. The CSC is designed to run at speeds up to 150 MHz supporting resolutions up to 1080p at 60 Hz. With any-to-any color space support, formats such as RGB, YUV, YCbCr, and others are supported by the CSC.

The main inputs, R_{IN} , G_{IN} , and B_{IN} , come from the 8-bit to 12-bit inputs from each channel. These inputs are based on the input format detailed in Table 9. The mapping of these inputs to the CSC inputs is shown in Table 8.

Table 8. CSC Port Mapping

Input Channel	CSC Input Channel
R/CR	R_{IN}
Gr/Y	G_{IN}
B/CB	B_{IN}

Table 9.

Port	Red								Green								Blue							
Bit	7	6	5	4	3	2	1	0	7	6	5	4	3	2	1	0	7	6	5	4	3	2	1	0
4:4:4	Red/CR [7:0]								Green/Y [7:0]								Blue/Cb [7:0]							
4:2:2	CbCr [7:0]								Y [7:0]								DDR 4:2:2 ↑ CbCr ↓ Y, Y							
4:4:4 DDR	DDR ↑ ¹ G [3:0]				DDR ↑ B [7:4]				DDR ↑ B [3:0]				DDR 4:2:2 ↑ CbCr [11:0]											
	DDR ↓ R [7:0]				DDR ↓ G [7:4]				DDR ↓ G [7:4]				DDR 4:2:2 ↓ Y, Y [11:0]											
4:2:2 to 12	CbCr [11:0]								Y [11:0]															

¹ Arrows in the table indicate clock edge. Rising edge of clock = ↑, falling edge = ↓.

One of the three channels is represented in Figure 6. In each processing channel, the three inputs are multiplied by three separate coefficients marked a1, a2, and a3. These coefficients are divided by 4096 to obtain nominal values ranging from -0.9998 to +0.9998. The variable labeled a4 is used as an offset control. The CSC_Mode setting is the same for all three processing channels. This multiplies all coefficients and offsets by a factor of 2^{CSC_Mode} .

The functional diagram for a single channel of the CSC, as shown in Figure 6, is repeated for the remaining G and B channels. The coefficients for these channels are b1, b2, b3, b4, c1, c2, c3, and c4.

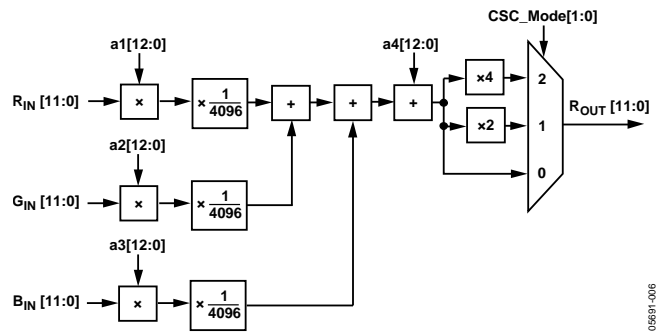

Figure 6. Single CSC Channel

A programming example and register settings for several common conversions are listed in the Color Space Converter (CSC) Common Settings section.

For a detailed functional description and more programming examples, refer to the Application Note [AN-795, AD9880 Color Space Converter User's Guide](#).

OUTPUT DATA FORMATS

The AD9398 supports 4:4:4, 4:2:2, double data-rate (DDR), and BT656 output formats. Register 0x25[3:0] controls the output mode. These modes and the pin mapping are illustrated in Table 8.

2-WIRE SERIAL REGISTER MAP

The AD9397 is initialized and controlled by a set of registers that determines the operating modes. An external controller is employed to write and read the control registers through the 2-wire serial interface port.

Table 10. Control Register Map

Hex Address	Read/Write or Read Only	Bits	Default Value	Register Name	Description
0x00	Read	[7:0]	00000000	Chip Revision	Chip revision ID.
0x11	Read/Write	[7]	0*****	HSYNC Source	0 = HSYNC. 1 = SOG.
		[6]	*0*****	HSYNC Source Override	0 = auto HSYNC source. 1 = manual HSYNC source.
		[5]	**0*****	VSYNC Source	0 = VSYNC. 1 = VSYNC from SOG.
		[4]	***0****	VSYNC Source Override	0 = auto HSYNC source. 1 = manual HSYNC source.
		[3]	****0***	Channel Select	0 = Channel 0. 1 = Channel 1.
		[2]	*****0**	Channel Select Override	0 = autochannel select. 1 = manual channel select.
		[1]	*****0*	Interface Select	0 = analog interface. 1 = digital interface.
		[0]	*****0	Interface Override	0 = auto-interface select. 1 = manual interface select.
0x12	Read/Write	[7]	1*****	Input HSYNC Polarity	0 = active low. 1 = active high.
		[6]	*0*****	HSYNC Polarity Override	0 = auto HSYNC polarity. 1 = manual HSYNC polarity.
		[5]	**1*****	Input VSYNC Polarity	0 = active low. 1 = active high.
		[4]	***0****	VSYNC Polarity Override	0 = auto VSYNC polarity. 1 = manual VSYNC polarity.
0x17	Read	[3:0]	****0000	HSYNCS per VSYNC MSB	MSB of HSYNCS per VSYNC.
0x18	Read	[7:0]	00000000	HSYNCS per VSYNC	HSYNCS per VSYNC count.
0x22	Read/Write	[7:0]	4	VSYNC Duration	VSYNC duration.
0x23	Read/Write	[7:0]	32	HSYNC Duration	HSYNC duration. Sets the duration of the output HSYNC in pixel clocks.
0x24	Read/Write	[7]	1*****	HSYNC Output Polarity	Output HSYNC polarity. 0 = active low out. 1 = active high out.
		[6]	*1*****	VSYNC Output Polarity	Output VSYNC polarity. 0 = active low out. 1 = active high out.
		[5]	**1*****	DE Output Polarity	Output DE polarity. 0 = active low out. 1 = active high out.

AD9397

Hex Address	Read/Write or Read Only	Bits	Default Value	Register Name	Description
		[4]	***1****	Field Output Polarity	Output field polarity. 0 = active low out. 1 = active high out.
		[0]	*****0	Output CLK Invert	0 = Don't invert clock out. 1 = Invert clock out.
0x25	Read/Write	[7:6]	01*****	Output CLK Select	Selects which clock to use on output pin. 1× CLK is divided down from TMDS clock input when pixel repetition is in use. 00 = ½× CLK. 01 = 1× CLK. 10 = 2× CLK. 11 = 90° phase 1× CLK.
		[5:4]	**11****	Output Drive Strength	Sets the drive strength of the outputs. 00 = lowest, 11 = highest.
		[3:2]	****00**	Output Mode	Selects which pins the data comes out on. 00 = 4:4:4 mode (normal). 01 = 4:2:2 + DDR 4:2:2 on blue. 10 = DDR 4:4:4 + DDR 4:2:2 on blue.
		[1]	*****1*	Primary Output Enable	Enables primary output.
		[0]	*****0	Secondary Output Enable	Enables secondary output (DDR 4:2:2 in Output Mode 1 and Mode 2).
0x26	Read/Write	[7]	0*****	Output Three-State	Three-state the outputs.
		[5]	**0*****	SPDIF Three-State	Three-state the SPDIF output.
		[4]	***0****	I ² S Three-State	Three-state the I ² S output and the MCLK out.
		[3]	****1***	Power-Down Pin Polarity	Sets polarity of power-down pin. 0 = active low. 1 = active high.
		[2:1]	****00*	Power-Down Pin Function	Selects the function of the power-down pin. 00 = power-down. 01 = power-down and three-state SOG. 10 = three-state outputs only. 11 = three-state outputs and SOG.
		[0]	*****0	Power-Down	0 = normal. 1 = power-down.
0x27	Read/Write	[7]	1*****	Auto Power-Down Enable	0 = disable auto low power state. 1 = enable auto low power state.
		[6]	*0*****	HDCP A0	Sets the LSB of the address of the HDCP I ² C. Set to 1 only for a second receiver in a dual-link configuration.
		[5]	**0*****	MCLK External Enable	0 = use internally generated MCLK. 1 = use external MCLK input.
		[4]	***0****	BT656 EN	If an external MCLK is used, it must be locked to the video clock according to the CTS and N available in the I ² C. Any mismatch between the internal MCLK and the input MCLK results in dropped or repeated audio samples.
		[3]	****0***	Force DE Generation	Enables EAV/SAV codes to be inserted into the video output data.
		[2:0]	*****000	Interface Offset	Allows use of the internal DE generator in DVI mode. Sets the difference (in HSYNCS) in field length between Field 0 and Field 1.

Hex Address	Read/Write or Read Only	Bits	Default Value	Register Name	Description
0x28	Read/Write	[7:2]	011000**	VS Delay	Sets the delay (in lines) from the VSYNC leading edge to the start of active video.
		[1:0]	*****01	HS Delay MSB	MSB, Register 0x29.
0x29	Read/Write	[7:0]	00000100	HS Delay	Sets the delay (in pixels) from the HSYNC leading edge to the start of active video.
0x2A	Read/Write	[3:0]	****0101	Line Width MSB	MSB, Register 0x2B.
0x2B	Read/Write	[7:0]	00000000	Line Width	Sets the width of the active video line in pixels.
0x2C	Read/Write	[3:0]	****0010	Screen Height MSB	MSB, Register 0x2D.
0x2D	Read/Write	[7:0]	11010000	Screen Height	Sets the height of the active screen in lines.
0x2E	Read/Write	[7]	0*****	Test 1	Must be written to 1 for proper operation.
0x2F	Read	[6]	*0*****	TMDS Sync Detect	Detects a TMDS DE.
		[5]	**0*****	TMDS Active	Detects a TMDS clock.
		[3]	****0***	HDCP Keys Read	Returns 1 when read of EEPROM keys is successful.
		[2:0]	*****000	DVI Quality	Returns quality number based on DE edges.
0x30	Read	[6]	*0*****	DVI Content Encrypted	This bit is high when HDCP decryption is in use (content is protected). The signal goes low when HDCP is not being used. Customers can use this bit to determine whether to allow copying of the content. The bit should be sampled at regular intervals because it can change on a frame-by-frame basis.
		[5]	**0*****	DVI HSYNC Polarity	Returns DVI HSYNC polarity.
		[4]	***0****	DVI VSYNC Polarity	Returns DVI VSYNC polarity.
0x31	Read/Write	[7:4]	1001****	MV Pulse Max	Sets the maximum pseudo sync pulse width for Macrovision detection.
		[3:0]	****0110	MV Pulse Min	Sets the minimum pseudo sync pulse width for Macrovision® detection.
0x32	Read/Write	[7]	0*****	MV Oversample En	Tells the Macrovision detection engine whether we are oversampling or not.
		[6]	*0*****	MV Pal En	Tells the Macrovision detection engine to enter PAL mode.
		[5:0]	**001101	MV Line Count Start	Sets the start line for Macrovision detection.
0x33	Read/Write	[7]	1*****	MV Detect Mode	0 = standard definition. 1 = progressive scan mode.
		[6]	*0*****	MV Settings Override	0 = use hard-coded settings for line counts and pulse widths. 1 = use I ² C values for these settings.
		[5:0]	**010101	MV Line Count End	Sets the end line for Macrovision detection.
0x34	Read/Write	[7:6]	10*****	MV Pulse Limit Set	Sets the number of pulses required in the last 3 lines (SD mode only).
		[5]	**0*****	Low Freq Mode	Sets audio PLL to low frequency mode. Low frequency mode should only be set for pixel clocks <80 MHz.
		[4]	***0****	Low Freq Override	Allows the previous bit to be used to set low frequency mode rather than the internal auto-detect.
		[3]	****0***	Up Conversion Mode	0 = repeat Cr and Cb values. 1 = interpolate Cr and Cb values.
		[2]	*****0**	CrCb Filter Enable	Enables the FIR filter for 4:2:2 CrCb output.
0x35	Read/Write	[6:5]	*01* ****	CSC_Mode	00 = ±1.0, -4096 to +4095. 01 = ±2.0, -8192 to +8190. 1× = ±4.0, -16384 to +16380.
		[4:0]	***01100	CSC_Coeff_A1 MSB	MSB, Register 0x36.

AD9397

Hex Address	Read/Write or Read Only	Bits	Default Value	Register Name	Description
0x36	Read/Write	[7:0]	01010010	CSC_Coeff_A1 LSB	Color space converter (CSC) coefficient for equation: $R_{OUT} = (A1 \times R_{IN}) + (A2 \times G_{IN}) + (A3 \times B_{IN}) + A4$ $G_{OUT} = (B1 \times R_{IN}) + (B2 \times G_{IN}) + (B3 \times B_{IN}) + B4$ $B_{OUT} = (C1 \times R_{IN}) + (C2 \times G_{IN}) + (C3 \times B_{IN}) + C4$
0x37	Read/Write	[4:0]	***01000	CSC_Coeff_A2 MSB	MSB, Register 0x38.
0x38	Read/Write	[7:0]	00000000	CSC_Coeff_A2 LSB	CSC coefficient for equation: $R_{OUT} = (A1 \times R_{IN}) + (A2 \times G_{IN}) + (A3 \times B_{IN}) + A4$ $G_{OUT} = (B1 \times R_{IN}) + (B2 \times G_{IN}) + (B3 \times B_{IN}) + B4$ $B_{OUT} = (C1 \times R_{IN}) + (C2 \times G_{IN}) + (C3 \times B_{IN}) + C4$
0x39	Read/Write	[4:0]	***00000	CSC_Coeff_A3 MSB	MSB, Register 0x3A.
0x3A	Read/Write	[7:0]	00000000	CSC_Coeff_A3 LSB	CSC coefficient for equation: $R_{OUT} = (A1 \times R_{IN}) + (A2 \times G_{IN}) + (A3 \times B_{IN}) + A4$ $G_{OUT} = (B1 \times R_{IN}) + (B2 \times G_{IN}) + (B3 \times B_{IN}) + B4$ $B_{OUT} = (C1 \times R_{IN}) + (C2 \times G_{IN}) + (C3 \times B_{IN}) + C4$
0x3B	Read/Write	[4:0]	***11001	CSC_Coeff_A4 MSB	MSB, Register 0x3C.
0x3C	Read/Write	[7:0]	11010111	CSC_Coeff_A4 LSB	CSC coefficient for equation: $R_{OUT} = (A1 \times R_{IN}) + (A2 \times G_{IN}) + (A3 \times B_{IN}) + A4$ $G_{OUT} = (B1 \times R_{IN}) + (B2 \times G_{IN}) + (B3 \times B_{IN}) + B4$ $B_{OUT} = (C1 \times R_{IN}) + (C2 \times G_{IN}) + (C3 \times B_{IN}) + C4$
0x3D	Read/Write	[4:0]	***11100	CSC_Coeff_B1 MSB	MSB, Register 0x3E.
0x3E	Read/Write	[7:0]	01010100	CSC_Coeff_B1 LSB	CSC coefficient for equation: $R_{OUT} = (A1 \times R_{IN}) + (A2 \times G_{IN}) + (A3 \times B_{IN}) + A4$ $G_{OUT} = (B1 \times R_{IN}) + (B2 \times G_{IN}) + (B3 \times B_{IN}) + B4$ $B_{OUT} = (C1 \times R_{IN}) + (C2 \times G_{IN}) + (C3 \times B_{IN}) + C4$
0x3F	Read/Write	[4:0]	***01000	CSC_Coeff_B2 MSB	MSB, Register 0x40.
0x40	Read/Write	[7:0]	00000000	CSC_Coeff_B2 LSB	CSC coefficient for equation: $R_{OUT} = (A1 \times R_{IN}) + (A2 \times G_{IN}) + (A3 \times B_{IN}) + A4$ $G_{OUT} = (B1 \times R_{IN}) + (B2 \times G_{IN}) + (B3 \times B_{IN}) + B4$ $B_{OUT} = (C1 \times R_{IN}) + (C2 \times G_{IN}) + (C3 \times B_{IN}) + C4$
0x41	Read/Write	[4:0]	***11110	CSC_Coeff_B3 MSB	MSB, Register 0x42.
0x42	Read/Write	[7:0]	10001001	CSC_Coeff_B3	CSC coefficient for equation: $R_{OUT} = (A1 \times R_{IN}) + (A2 \times G_{IN}) + (A3 \times B_{IN}) + A4$ $G_{OUT} = (B1 \times R_{IN}) + (B2 \times G_{IN}) + (B3 \times B_{IN}) + B4$ $B_{OUT} = (C1 \times R_{IN}) + (C2 \times G_{IN}) + (C3 \times B_{IN}) + C4$
0x43	Read/Write	[4:0]	***00010	CSC_Coeff_B4 MSB	MSB, Register 0x44.
0x44	Read/Write	[7:0]	10010010	CSC_Coeff_B4 LSB	CSC coefficient for equation: $R_{OUT} = (A1 \times R_{IN}) + (A2 \times G_{IN}) + (A3 \times B_{IN}) + A4$ $G_{OUT} = (B1 \times R_{IN}) + (B2 \times G_{IN}) + (B3 \times B_{IN}) + B4$ $B_{OUT} = (C1 \times R_{IN}) + (C2 \times G_{IN}) + (C3 \times B_{IN}) + C4$
0x45	Read/Write	[4:0]	***00000	CSC_Coeff_C1 MSB	MSB, Register 0x46.
0x46	Read/Write	[7:0]	00000000	CSC_Coeff_C1 LSB	CSC coefficient for equation: $R_{OUT} = (A1 \times R_{IN}) + (A2 \times G_{IN}) + (A3 \times B_{IN}) + A4$ $G_{OUT} = (B1 \times R_{IN}) + (B2 \times G_{IN}) + (B3 \times B_{IN}) + B4$ $B_{OUT} = (C1 \times R_{IN}) + (C2 \times G_{IN}) + (C3 \times B_{IN}) + C4$
0x47	Read/Write	[4:0]	***01000	CSC_Coeff_C2 MSB	MSB, Register 0x48.
0x48	Read/Write	[7:0]	00000000	CSC_Coeff_C2 LSB	CSC coefficient for equation: $R_{OUT} = (A1 \times R_{IN}) + (A2 \times G_{IN}) + (A3 \times B_{IN}) + A4$ $G_{OUT} = (B1 \times R_{IN}) + (B2 \times G_{IN}) + (B3 \times B_{IN}) + B4$ $B_{OUT} = (C1 \times R_{IN}) + (C2 \times G_{IN}) + (C3 \times B_{IN}) + C4$

Hex Address	Read/Write or Read Only	Bits	Default Value	Register Name	Description
0x49	Read/Write	[4:0]	***01110	CSC_Coeff_C3 MSB	MSB, Register 0x4A.
0x4A	Read/Write	[7:0]	10000111	CSC_Coeff_C3 LSB	CSC coefficient for equation: $R_{OUT} = (A1 \times R_{IN}) + (A2 \times G_{IN}) + (A3 \times B_{IN}) + A4$ $G_{OUT} = (B1 \times R_{IN}) + (B2 \times G_{IN}) + (B3 \times B_{IN}) + B4$ $B_{OUT} = (C1 \times R_{IN}) + (C2 \times G_{IN}) + (C3 \times B_{IN}) + C4$
0x4B	Read/Write	[4:0]	***11000	CSC_Coeff_C4 MSB	MSB, Register 0x4C.
0x4C	Read/Write	[7:0]	10111101	CSC_Coeff_C4 LSB	CSC coefficient for equation: $R_{OUT} = (A1 \times R_{IN}) + (A2 \times G_{IN}) + (A3 \times B_{IN}) + A4$ $G_{OUT} = (B1 \times R_{IN}) + (B2 \times G_{IN}) + (B3 \times B_{IN}) + B4$ $B_{OUT} = (C1 \times R_{IN}) + (C2 \times G_{IN}) + (C3 \times B_{IN}) + C4$
0x50	Read/Write	[7:0]	00100000	Test	Must be written to 0x20 for proper operation.
0x56	Read/Write	[7:0]	00001111	Test	Must be written to default of 0x0F for proper operation.
0x59	Read/Write	[6] [5] [4] [0]		MDA/MCL PU CLK Term O/R Manual CLK Term MDA/MCL Three-State	This disables the MDA/MCL pull-ups. Clock termination power-down override: 0 = auto, 1 = manual. Clock termination: 0 = normal, 1 = disconnected. This bit three-states the MDA/MCL lines.

2-WIRE SERIAL CONTROL REGISTER DETAILS

CHIP IDENTIFICATION

0x00—Bit[7:0] Chip Revision

An 8-bit value that reflects the current chip revision.

0x11—Bit[7] HSYNC Source

0 = HSYNC, 1 = SOG. The power-up default is 0. These selections are ignored if Register 0x11, Bit 6 = 0.

0x11—Bit[6] HSYNC Source Override

0 = auto HSYNC source, 1 = manual HSYNC source. Manual HSYNC source is defined in Register 0x11, Bit 7. The power-up default is 0.

0x11—Bit[5] VSYNC Source

0 = VSYNC, 1 = VSYNC from SOG. The power-up default is 0. These selections are ignored if Register 0x11, Bit 4 = 0.

0x11—Bit[4] VSYNC Source Override

0 = auto VSYNC source, 1 = manual VSYNC source. Manual VSYNC source is defined in Register 0x11, Bit 5. The power-up default is 0.

0x11—Bit[3] Channel Select

0 = Channel 0, 1 = Channel 1. The power-up default is 0. These selections are ignored if Register 0x11, Bit 2 = 0.

0x11—Bit[2] Channel Select Override

0 = auto channel select, 1 = manual channel select. Manual channel select is defined in Register 0x11, Bit 3. The power-up default is 0.

0x11—Bit[1] Interface Select

0 = analog interface, 1 = digital interface. The power-up default is 0. These selections are ignored if Register 0x11, Bit 0 = 0.

0x11—Bit[0] Interface Select Override

0 = auto interface select, 1 = manual interface select. Manual interface select is defined in Register 0x11, Bit 1. The power-up default is 0.

0x12—Bit[7] Input HSYNC Polarity

0 = active low, 1 = active high. The power-up default is 1. These selections are ignored if Register 10x2, Bit 6 = 0.

0x12—Bit[6] HSYNC Polarity Override

0 = auto HSYNC polarity, 1 = manual HSYNC polarity. Manual HSYNC polarity is defined in Register 0x11, Bit 7. The power-up default is 0.

0x12—Bit[5] Input VSYNC Polarity

0 = active low, 1 = active high. The power-up default is 1. These selections are ignored if Register 0x11, Bit 4 = 0.

0x12—Bit[4] VSYNC Polarity Override

0 = auto VSYNC polarity, 1 = manual VSYNC polarity. Manual VSYNC polarity is defined in Register 0x11, Bit 5. The power-up default is 0.

0x17—Bits[3:0] HSYNCs per VSYNC MSBs

The 4 MSBs of the 12-bit counter that reports the number of HSYNCs/VSYNC on the active input. This is useful in determining the mode and aids in setting the PLL divide ratio.

0x18—Bit[7:0] HSYNCs per VSYNC LSBs

The 8 LSBs of the 12-bit counter that reports the number of HSYNCs/VSYNC on the active input.

0x21—Bit[5] VSYNC Filter Enable

The purpose of the VSYNC filter is to guarantee the position of the VSYNC edge with respect to the HSYNC edge and to generate a field signal. The filter works by examining the placement of VSYNC and regenerating a correctly placed VSYNC one line later. The VSYNC is first checked to see whether it occurs in the Field 0 position or the Field 1 position. This is done by checking the leading edge position against the sync separator threshold and the HSYNC position. The HSYNC width is divided into four quadrants with Quadrant 1 starting at the HSYNC leading edge plus a sync separator threshold. If the VSYNC leading edge occurs in Quadrant 1 or Quadrant 4, the field is set to 0 and the output VSYNC is placed coincident with the HSYNC leading edge. If the VSYNC leading edge occurs in Quadrant 2 or Quadrant 3, the field is set to 1 and the output VSYNC leading edge is placed in the center of the line. In this way, the VSYNC filter creates a predictable relative position between HSYNC and VSYNC edges at the output.

If the VSYNC occurs near the HSYNC edge, this guarantees that the VSYNC edge follows the HSYNC edge. This performs filtering also in that it requires a minimum of 64 lines between VSYNCs. The VSYNC filter cleans up extraneous pulses that might occur on the VSYNC. This should be enabled whenever the HSYNC/VSYNC count is used. Setting this bit to 0 disables the VSYNC filter. Setting this bit to 1 enables the VSYNC filter. Power-up default is 0.

0x21—Bit[4] VSYNC Duration Enable

This enables the VSYNC duration block which is designed to be used with the VSYNC filter. Setting the bit to 0 leaves the VSYNC output duration unchanged; setting the bit to 1 sets the VSYNC output duration based on Register 0x22. The power-up default is 0.

0x22—Bits[7:0] VSYNC Duration

This is used to set the output duration of the VSYNC, and is designed to be used with the VSYNC filter. This is valid only if Register 0x21, Bit 4 is set to 1. Power-up default is 4.

0x23—Bit[7:0] HSYNC Duration

An 8-bit register that sets the duration of the HSYNC output pulse. The leading edge of the HSYNC output is triggered by the internally generated, phase-adjusted PLL feedback clock. The AD9397 then counts a number of pixel clocks equal to the value in this register. This triggers the trailing edge of the HSYNC output, which is also phase-adjusted. The power-up default is 32.

0x24—Bit[7] HSYNC Output Polarity

This bit sets the polarity of the HSYNC output. Setting this bit to 0 sets the HSYNC output to active low. Setting this bit to 1 sets the HSYNC output to active high. Power-up default setting is 1.

0x24—Bit[6] VSYNC Output Polarity

This bit sets the polarity of the VSYNC output (both DVI and analog). Setting this bit to 0 sets the VSYNC output to active low. Setting this bit to 1 sets the VSYNC output to active high. Power-up default is 1.

0x24—Bit[5] Display Enable Output Polarity

This bit sets the polarity of the display enable (DE) for both DVI and analog. 0 = DE output polarity is negative. 1 = DE output polarity is positive. The power-up default is 1.

0x24—Bit[4] Field Output Polarity

This bit sets the polarity of the field output signal (both DVI and analog) on Pin 21. 0 = active low out = even field; active high = odd field. 1 = active high out = odd field; active high = even field. The power-up default is 1.

0x24—Bit[0] Output Clock Invert

This bit allows inversion of the output clock as specified by Register 0x25, Bits 7 to 6. 0 = noninverted clock. 1 = inverted clock. The power-up default setting is 0.

0x25—Bits[7:6] Output Clock Select

These bits select the clock output on the DATACLK pin. They include 1/2× clock, a 2× clock, a 90° phase shifted clock, or the normal pixel clock. The power-up default setting is 01.

Table 11. Output Clock Select

Select	Result
00	½× pixel clock
01	1× pixel clock
10	2× pixel clock
11	90° phase 1× pixel clock

0x25—Bit[5:4] Output Drive Strength

These two bits select the drive strength for all the high speed digital outputs (except VSOUT, A0 and O/E field). Higher drive strength results in faster rise/fall times and in general makes it easier to capture data. Lower drive strength results in slower rise/fall times and helps to reduce EMI and digitally generated power supply noise. The power-up default setting is 11.

Table 12. Output Drive Strength

Output Drive	Result
00	Low output drive strength
01	Medium low output drive strength
10	Medium high output drive strength
11	High output drive strength

0x25—Bits[3:2] Output Mode

These bits choose between four options for the output mode, one of which is exclusive to an HDMI input. 4:4:4 mode is standard RGB; 4:2:2 mode is YCrCb, which reduces the number of active output pins from 24 to 16; 4:4:4 is double data rate (DDR) output mode; and the data is RGB mode, but changes on every clock edge. The power-up default setting is 00.

Table 13. Output Mode

Output Mode	Result
00	4:4:4 RGB mode
01	4:2:2 YCrCb mode + DDR 4:2:2 on blue (secondary)
10	DDR 4:4:4: DDR mode + DDR 4:2:2 on blue (secondary)
11	12-bit 4:2:2 (HDMI option only)

0x25—Bit[1] Primary Output Enable

This bit places the primary output in active or high impedance mode. The primary output is designated when using either 4:2:2 or DDR 4:4:4. In these modes, the data on the red and green output channels is the primary output, while the output data on the blue channel (DDR YCrCb) is the secondary output. 0 = primary output is in high impedance mode. 1 = primary output is enabled. The power-up default setting is 1.

0x25—Bit[0] Secondary Output Enable

This bit places the secondary output in active or high impedance mode. The secondary output is designated when using either 4:2:2 or DDR 4:4:4. In these modes, the data on the blue output channel is the secondary output while the output data on the red and green channels is the primary output. Secondary output is always a DDR YCrCb data mode. The power-up default setting is 0. 0 = secondary output is in high impedance mode. 1 = secondary output is enabled.

0x26—Bit[7] Output Three-State

When enabled, this bit puts all outputs (except SOGOUT) in a high impedance state. 0 = normal outputs. 1 = all outputs (except SOGOUT) in high impedance mode. The power-up default setting is 0.

0x26—Bit[3] Power-Down Polarity

This bit defines the polarity of the input power-down pin. 0 = power-down pin is active low. 1 = power-down pin is active high. The power-up default setting is 1.

0x26—Bits[2:1] Power-Down Pin Function

These bits define the different operational modes of the power-down pin. These bits are functional only when the power-down pin is active; when it is not active, the part is powered up and functioning. 0x = the chip is powered down and all outputs are in high impedance mode. 1x = the chip remains powered up, but all outputs are in high impedance mode. The power-up default setting is 00.

0x26—Bit[0] Power-Down

This bit is used to put the chip in power-down mode. In this mode, the power dissipation is reduced to a fraction of the typical power (see Table 1 for exact power dissipation). When in power-down, the HSOUT, VSOUT, DATAACK, and all 30 of the data outputs are put into a high impedance state. Note that the SOGOUT output is not put into high impedance. Circuit blocks that continue to be active during power-down include the voltage references, sync processing, sync detection, and the serial register. These blocks facilitate a fast start-up from power-down. 0 = normal operation. 1 = power-down. The power-up default setting is 0.

0x27—Bit[7] Auto Power-Down Enable

This bit enables the chip to go into low power mode, or seek mode if no sync inputs are detected. 0 = auto power-down disabled. 1 = chip powers down if no sync inputs present. The power-up default setting is 1.

0x27—Bit[6] HDCP A0 Address

This bit sets the LSB of the address of the HDCP I²C. This should be set to 1 only for a second receiver in a dual-link configuration. The power-up default is 0.

BT656 GENERATION**0x27—Bit[4] BT656 Enable**

This bit enables the output to be BT656 compatible with the defined start of active video (SAV) and end of active video (EAV) controls to be inserted. These require specification of the number of active lines, active pixels per line, and delays to place these markers. 0 = disable BT656 video mode. 1 = enable BT656 video mode. The power-up default setting is 0.

0x27—Bit[3] Force DE Generation

This bit allows the use of the internal DE generator in DVI mode. 0 = internal DE generation disabled. 1 = force DE generation via programmed registers. The power-up default setting is 0.

0x27—Bits[2:0] Interlace Offset

These bits define the offset in HSYNCs from Field 0 to Field 1. The power-up default setting is 000.

0x28—Bits[7:2] VSYNC Delay

These bits set the delay (in lines) from the leading edge of VSYNC to active video. The power-up default setting is 24.

0x28—Bit[1:0] HSYNC Delay MSBs

These 2 bits and the following 8 bits set the delay (in pixels) from the HSYNC leading edge to the start of active video. The power-up default setting is 0x104.

0x29—Bits[7:0] HSYNC Delay LSBs

See the HSYNC Delay MSBs section.

0x2A—Bits[3:0] Line Width MSBs

These 4 bits and the following 8 bits set the width of the active video line (in pixels). The power-up default setting is 0x500.

0x2B—Bits[7:0] Line Width LSBs

See the line width MSBs section.

0x2C—Bits[3:0] Screen Height MSBs

These 4 bits and the following 8 bits set the height of the active screen (in lines). The power-up default setting is 0x2D0.

0x2D—Bits[7:0] Screen Height LSBs

See the Screen Height MSBs section.

0x2F—Bit[6] TMDS Sync Detect

This read-only bit indicates the presence of a TMDS DE. 0 = no TMDS DE present. 1 = TMDS DE detected.

0x2F—Bit[5] TMDS Active

This read-only bit indicates the presence of a TMDS clock. 0 = no TMDS clock present. 1 = TMDS clock detected.

0x2F—Bit[3] HDCP Keys Read

This read-only bit reports if the HDCP keys were read successfully. 0 = failure to read HDCP keys. 1 = HDCP keys read.

0x2F—Bits[2:0] DVI Quality

These read-only bits indicate a level of DVI quality based on the DE edges. A larger number indicates a higher quality.

0x30—Bit[6] DVI Content Encrypted

This read-only bit is high when HDCP decryption is in use (content is protected). The signal goes low when HDCP is not being used. Customers can use this bit to allow copying of the content. The bit should be sampled at regular intervals because it can change on a frame-by-frame basis. 0 = HDCP not in use. 1 = HDCP decryption in use.

0x30—Bit[5] DVI HSYNC Polarity

This read-only bit indicates the polarity of the DVI HSYNC. 0 = DVI HSYNC polarity is low active. 1 = DVI HSYNC polarity is high active.

0x30—Bit[4] DVI VSYNC Polarity

This read-only bit indicates the polarity of the DVI VSYNC. 0 = DVI VSYNC polarity is low active. 1 = DVI VSYNC polarity is high active.

MACROVISION**0x31—Bits[7:4] Macrovision Pulse Max**

These bits set the pseudo sync pulse width maximum for Macrovision detection in pixel clocks. This is functional for 13.5 MHz SDTV or 27 MHz progressive scan. Power-up default is 9.

0x31—Bits[3:0] Macrovision Pulse Min

These bits set the pseudo sync pulse width minimum for Macrovision detection in pixel clocks. This is functional for 13.5 MHz SDTV or 27 MHz progressive scan. Power up default is 6.

0x32—Bit[7] Macrovision Oversample Enable

Tells the Macrovision detection engine whether oversampling is used. This accommodates 27 MHz sampling for SDTV and 54 MHz sampling for progressive scan and is used as a correction factor for clock counts. Power-up default is 0.

0x32—Bit[6] Macrovision PAL Enable

Tells the Macrovision detection engine to enter PAL mode when set to 1. Default is 0 for NTSC mode.

0x32—Bits[5:0] Macrovision Line Count Start

Set the start line for Macrovision detection. Along with Register 0x33, Bits [5:0], they define the region where MV pulses are expected to occur. The power-up default is Line 13.

0x33—Bit[7] Macrovision Detect Mode

0 = standard definition. 1 = progressive scan mode

0x33—Bit[6] Macrovision Settings Override

This defines whether preset values are used for the MV line counts and pulse widths or the values stored in I²C registers are used. 0 = use hard-coded settings for line counts and pulse widths. 1 = use I²C values for these settings.

0x33—Bits[5:0] Macrovision Line Count End

Set the end line for Macrovision detection. Along with Register 0x32, Bits [5:0], they define the region where MV pulses are expected to occur. The power-up default is Line 21.

0x34—Bits[7:6] Macrovision Pulse Limit Select

Set the number of pulses required in the last three lines (SD mode only). If there is not at least this number of MV pulses, the engine stops. These two bits define these pulse counts:

- 00 = 6.
- 01 = 4.
- 10 = 5 (default).
- 11 = 7.

0x34—Bit[5] Low Frequency Mode

Sets whether the audio PLL is in low frequency mode or not. Low frequency mode should only be set for pixel clocks <80 MHz.

0x34—Bit[4] Low Frequency Override

Allows the previous bit to be used to set low frequency mode rather than the internal autodetect.

0x34—Bit[3] Upconversion Mode

0 = repeat Cb/Cr values. 1 = interpolate Cb/Cr values.

0x34—Bit[2] CbCr Filter Enable

Enables the FIR filter for 4:2:2 CbCr output.

COLOR SPACE CONVERSION

The default power-up values for the color space converter coefficients (R0x35 through R0x4C) are set for ATSC RGB-to-YCbCr conversion. They are completely programmable for other conversions.

0x34—Bit[1] Color Space Converter Enable

This bit enables the color space converter. 0 = disable color space converter. 1 = enable color space converter. The power-up default setting is 0.

0x35—Bits[6:5] Color Space Converter Mode

These two bits set the fixed-point position of the CSC coefficients, including the A4, B4, and C4 offsets. Default = 01.

Table 14. CSC Fixed Point Converter Mode

Select	Result
00	±1.0, -4096 to +4095
01	±2.0, -8192 to +8190
1x	±4.0, -16384 to +16380

0x35—Bits[4:0] Color Space Conversion Coefficient A1 MSBs

These 5 bits form the 5 MSBs of the Color Space Conversion Coefficient A1. This combined with the 8 LSBs of the following register form a 13-bit, twos complement coefficient which is user programmable. The equation takes the form of:

$$\begin{aligned}R_{OUT} &= (A1 \times R_{IN}) + (A2 \times G_{IN}) + (A3 \times B_{IN}) + A4 \\G_{OUT} &= (B1 \times R_{IN}) + (B2 \times G_{IN}) + (B3 \times B_{IN}) + B4 \\B_{OUT} &= (C1 \times R_{IN}) + (C2 \times G_{IN}) + (C3 \times B_{IN}) + C4\end{aligned}$$

The default value for the 13-bit A1 coefficient is 0x0C52.

0x36—Bits[7:0] Color Space Conversion Coefficient A1 LSBs

See the Register 0x35 section.

0x37—Bits[4:0] CSC A2 MSBs

These five bits form the 5 MSBs of the Color Space Conversion Coefficient A2. Combined with the 8 LSBs of the following register they form a 13-bit, twos complement coefficient that is user programmable. The equation takes the form of:

$$\begin{aligned}R_{OUT} &= (A1 \times R_{IN}) + (A2 \times G_{IN}) + (A3 \times B_{IN}) + A4 \\G_{OUT} &= (B1 \times R_{IN}) + (B2 \times G_{IN}) + (B3 \times B_{IN}) + B4 \\B_{OUT} &= (C1 \times R_{IN}) + (C2 \times G_{IN}) + (C3 \times B_{IN}) + C4\end{aligned}$$

The default value for the 13-bit A2 coefficient is 0x0800.

0x38—Bits[7:0] CSC A2 LSBs

See the Register 0x37 section.

0x39—Bits[4:0] CSC A3 MSBs

The default value for the 13-bit A3 is 0x0000.

0x3A—Bits[7:0] CSC A3 LSBs**0x3B—Bits[4:0] CSC A4 MSBs**

The default value for the 13-bit A4 is 0x19D7.

0x3C—Bits[7:0] CSC A4 LSBs**0x3D—Bits[4:0] CSC B1 MSBs**

The default value for the 13-bit B1 is 0x1C54.

0x3E—Bits[7:0] CSC B1 LSBs**0x3F—Bits[4:0] CSC B2 MSBs**

The default value for the 13-bit B2 is 0x0800.

0x40—Bits[7:0] CSC B2 LSBs**0x41—Bits[4:0] CSC B3 MSBs**

The default value for the 13-bit B3 is 0x1E89.

0x42—Bit[7:0] CSC B3 LSBs**0x43—Bit[4:0] CSC B4 MSBs**

The default value for the 13-bit B4 is 0x0291.

0x44—Bits[7:0] CSC B4 LSBs**0x45—Bits[4:0] CSC C1 MSBs**

The default value for the 13-bit C1 is 0x0000.

0x46—Bits[7:0] CSC C1 LSBs**0x47—Bits[4:0] CSC C2 MSBs**

The default value for the 13-bit C2 is 0x0800.

0x48—Bits[7:0] CSC C2 LSBs**0x49—Bits[4:0] CSC C3 MSBs**

The default value for the 13-bit C3 is 0x0E87.

0x4A—Bits[7:0] CSC C3 LSBs**0x4B—Bits[4:0] CSC C4 MSBs**

The default value for the 13-bit C4 is 0x18BD.

0x4C—Bits[7:0] CSC C4 LSBs**0x59—Bit[6] MDA/MCL PU Disable**

This bit disables the inter-MDA/MCL pull-ups.

0x59—Bit[5] CLK Term O/R

This bit allows for overriding during power down. 0 = auto, 1 = manual.

0x59—Bit[4] Manual CLK Term

This bit allows normal clock termination or disconnects this. 0 = normal, 1 = disconnected.

0x59—Bit[0] MDA/MCL Three-State

This bit three-states the MDA/MCL lines to allow in-circuit programming of the EEPROM.

2-WIRE SERIAL CONTROL PORT

A 2-wire serial interface control interface is provided in the AD9397. Up to two AD9397 devices can be connected to the 2-wire serial interface, with a unique address for each device.

The 2-wire serial interface comprises a clock (SCL) and a bidirectional data (SDA) pin. The analog flat panel interface acts as a slave for receiving and transmitting data over the serial interface. When the serial interface is not active, the logic levels on SCL and SDA are pulled high by external pull-up resistors.

Data received or transmitted on the SDA line must be stable for the duration of the positive-going SCL pulse. Data on SDA must change only when SCL is low. If SDA changes state while SCL is high, the serial interface interprets that action as a start or stop sequence.

There are six components to serial bus operation:

- Start signal
- Slave address byte
- Base register address byte
- Data byte to read or write
- Stop signal
- Acknowledge (Ack)

When the serial interface is inactive (SCL and SDA are high), communications are initiated by sending a start signal. The start signal is a high-to-low transition on SDA while SCL is high. This signal alerts all slave devices that a data transfer sequence is coming.

The first 8 bits of data transferred after a start signal comprise a 7-bit slave address (the first 7 bits) and a single R/W bit (the eighth bit). The R/W bit indicates the direction of data transfer, read from (1) or write to (0) the slave device. If the transmitted slave address matches the address of the device (set by the state of the SA0 input pin as shown in Table 15), the AD9397 acknowledges by bringing SDA low on the 9th SCL pulse. If the addresses do not match, the AD9397 does not acknowledge.

Table 15. Serial Port Addresses

Bit 7	Bit 6	Bit 5	Bit 4	Bit 3	Bit 2	Bit 1
A ₆ (MSB)	A ₅	A ₄	A ₃	A ₂	A ₁	A ₀
1	0	0	1	1	0	0

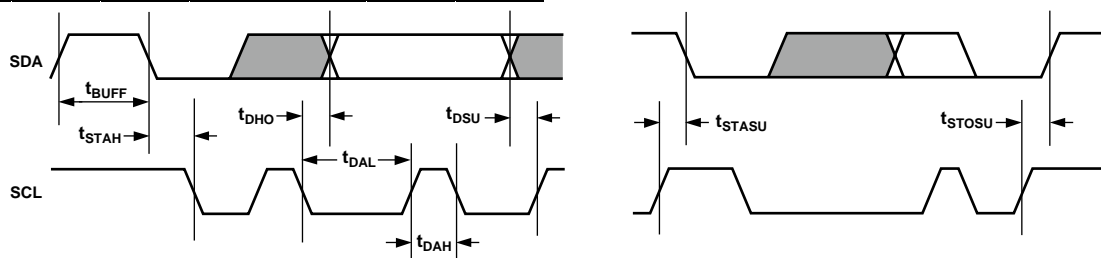

Figure 7. Serial Port Read/Write Timing

DATA TRANSFER VIA SERIAL INTERFACE

For each byte of data read or written, the MSB is the first bit of the sequence.

If the AD9397 does not acknowledge the master device during a write sequence, the SDA remains high so the master can generate a stop signal. If the master device does not acknowledge the AD9397 during a read sequence, the AD9397 interprets this as the end of data. The SDA remains high, so the master can generate a stop signal.

To write data to specific control registers of the AD9397, the 8-bit address of the control register of interest must be written after the slave address has been established. This control register address is the base address for subsequent write operations. The base address auto-increments by 1 for each byte of data written after the data byte intended for the base address. If more bytes are transferred than there are available addresses, the address does not increment and remains at its maximum value. Any base address higher than the maximum value does not produce an acknowledge signal.

Data are read from the control registers of the AD9397 in a similar manner. Reading requires two data transfer operations:

- The base address must be written with the R/W bit of the slave address byte low to set up a sequential read operation.
- Reading (the R/W bit of the slave address byte high) begins at the previously established base address. The address of the read register auto-increments after each byte is transferred.

To terminate a read/write sequence to the AD9397, a stop signal must be sent. A stop signal comprises a low-to-high transition of SDA while SCL is high.

A repeated start signal occurs when the master device driving the serial interface generates a start signal without first generating a stop signal to terminate the current communication. This is used to change the mode of communication (read, write) between the slave and master without releasing the serial interface lines.

SERIAL INTERFACE READ/WRITE EXAMPLES

Write to one control register:

- Start signal
- Slave address byte ($\overline{R/\overline{W}}$ bit = low)
- Base address byte
- Data byte to base address
- Stop signal

Write to four consecutive control registers:

- Start signal
- Slave address byte ($\overline{R/\overline{W}}$ bit = low)
- Base address byte
- Data byte to base address
- Data byte to (base address + 1)
- Data byte to (base address + 2)
- Data byte to (base address + 3)
- Stop signal

Read from one control register:

- Start signal
- Slave address byte ($\overline{R/\overline{W}}$ bit = low)
- Base address byte
- Start signal
- Slave address byte ($\overline{R/\overline{W}}$ bit = high)
- Data byte from base address
- Stop signal

Read from four consecutive control registers:

- Start signal
- Slave address byte ($\overline{R/\overline{W}}$ bit = low)
- Base address byte
- Start signal
- Slave address byte ($\overline{R/\overline{W}}$ bit = high)
- Data byte from base address
- Data byte from (base address + 1)
- Data byte from (base address + 2)
- Data byte from (base address + 3)
- Stop signal

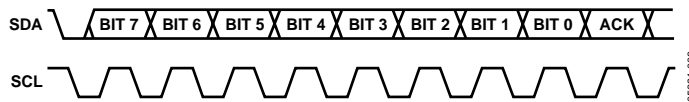

Figure 8. Serial Interface—Typical Byte Transfer

PCB LAYOUT RECOMMENDATIONS

The AD9397 is a high precision, high speed digital device. To achieve the maximum performance from the part, it is important to have a well laid-out board. The following is a guide for designing a board using the AD9397.

POWER SUPPLY BYPASSING

It is recommended to bypass each power supply pin with a 0.1 μF capacitor. The exception is in the case where two or more supply pins are adjacent to each other. For these groupings of powers/grounds, it is only necessary to have one bypass capacitor. The fundamental idea is to have a bypass capacitor within about 0.5 cm of each power pin. Also, avoid placing the capacitor on the opposite side of the PC board from the AD9397, because that interposes resistive vias in the path.

The bypass capacitors should be physically located between the power plane and the power pin. Current should flow from the power plane to the capacitor to the power pin. Do not make the power connection between the capacitor and the power pin. Placing a via underneath the capacitor pads down to the power plane is generally the best approach.

It is particularly important to maintain low noise and good stability of PV_{DD} (the clock generator supply). Abrupt changes in PV_{DD} can result in similarly abrupt changes in sampling clock phase and frequency. This can be avoided by careful attention to regulation, filtering, and bypassing. It is highly desirable to provide separate regulated supplies for each of the analog circuitry groups (V_{D} and PV_{DD}).

Some graphic controllers use substantially different levels of power when active (during active picture time) and when idle (during HSYNC and VSYNC periods). This can result in a measurable change in the voltage supplied to the analog supply regulator, which can in turn produce changes in the regulated analog supply voltage. This can be mitigated by regulating the analog supply, or at least PV_{DD} , from a different, cleaner power source (for example, from a 12 V supply).

It is recommended to use a single ground plane for the entire board. Experience has repeatedly shown that the noise performance is the same or better with a single ground plane. Using multiple ground planes can be detrimental because each separate ground plane is smaller and long ground loops can result.

In some cases, using separate ground planes is unavoidable, so it is recommend to place a single ground plane under the AD9397. The location of the split should be at the receiver of the digital outputs. In this case, it is even more important to place components wisely because the current loops are much longer (current takes the path of least resistance). An example of a current loop is: power plane to AD9397 to digital output trace to digital data receiver to digital ground plane.

OUTPUTS (BOTH DATA AND CLOCKS)

Try to minimize the trace length that the digital outputs have to drive. Longer traces have higher capacitance, which require more current that causes more internal digital noise.

Shorter traces reduce the possibility of reflections.

Adding a 50 Ω to 200 Ω series resistor can suppress reflections, reduce EMI, and reduce the current spikes inside the AD9397. If series resistors are used, place them as close as possible to the AD9397 pins (although try not to add vias or extra length to the output trace to move the resistors closer).

If possible, limit the capacitance that each of the digital outputs drives to less than 10 pF. This can be accomplished easily by keeping traces short and by connecting the outputs to only one device. Loading the outputs with excessive capacitance increases the current transients inside of the AD9397 and creates more digital noise on its power supplies.

DIGITAL INPUTS

The digital inputs on the AD9397 were designed to work with 3.3 V signals, but are tolerant of 5.0 V signals. Therefore, no extra components need to be added if using 5.0 V logic.

Any noise that enters the HSYNC input trace can add jitter to the system. Therefore, minimize the trace length and do not run any digital or other high frequency traces near it.

COLOR SPACE CONVERTER (CSC) COMMON SETTINGS

Table 16. HDTV YCrCb (0 to 255) to RGB (0 to 255) (Default Setting for AD9397)

Register	Red/Cr Coeff 1		Red/Cr Coeff 2		Red/Cr Coeff 3		Red/Cr Offset	
Address	0x35	0x36	0x37	0x38	0x39	0x3A	0x3B	0x3C
Value	0x2C	0x52	0x08	0x00	0x00	0x00	0x19	0xD7
Register	Green/Y Coeff 1		Green/Y Coeff 2		Green/Y Coeff 3		Green/Y Offset	
Address	0x3D	0x3E	0x3F	0x40	0x41	0x42	0x43	0x44
Value	0x1C	0x54	0x08	0x00	0x3E	0x89	0x02	0x91
Register	Blue/Cb Coeff 1		Blue/Cb Coeff 2		Blue/Cb Coeff 3		Blue/Cb Offset	
Address	0x45	0x46	0x47	0x48	0x49	0x4A	0x4B	0x4C
Value	0x00	0x00	0x08	0x00	0x0E	0x87	0x18	0xBD

Table 17. HDTV YCrCb (16 to 235) to RGB (0 to 255)

Register	Red/Cr Coeff 1		Red/Cr Coeff 2		Red/Cr Coeff 3		Red/Cr Offset	
Address	0x35	0x36	0x37	0x38	0x39	0x3A	0x3B	0x3C
Value	0x47	0x2C	0x04	0xA8	0x00	0x00	0x1C	0x1F
Register	Green/Y Coeff 1		Green/Y Coeff 2		Green/Y Coeff 3		Green/Y Offset	
Address	0x3D	0x3E	0x3F	0x40	0x41	0x42	0x43	0x44
Value	0x1D	0xDD	0x04	0xA8	0x1F	0x26	0x01	0x34
Register	Blue/Cb Coeff 1		Blue/Cb Coeff 2		Blue/Cb Coeff 3		Blue/Cb Offset	
Address	0x45	0x46	0x47	0x48	0x49	0x4A	0x4B	0x4C
Value	0x00	0x00	0x04	0xA8	0x08	0x75	0x1B	0x7B

Table 18. SDTV YCrCb (0 to 255) to RGB (0 to 255)

Register	Red/Cr Coeff 1		Red/Cr Coeff 2		Red/Cr Coeff 3		Red/Cr Offset	
Address	0x35	0x36	0x37	0x38	0x39	0x3A	0x3B	0x3C
Value	0x2A	0xF8	0x08	0x00	0x00	0x00	0x1A	0x84
Register	Green/Y Coeff 1		Green/Y Coeff 2		Green/Y Coeff 3		Green/Y Offset	
Address	0x3D	0x3E	0x3F	0x40	0x41	0x42	0x43	0x44
Value	0x1A	0x6A	0x08	0x00	0x1D	0x50	0x04	0x23
Register	Blue/Cb Coeff. 1		Blue/Cb Coeff 2		Blue/Cb Coeff 3		Blue/Cb Offset	
Address	0x45	0x46	0x47	0x48	0x49	0x4A	0x4B	0x4C
Value	0x00	0x00	0x08	0x00	0x0D	0xDB	0x19	0x12

Table 19. SDTV YCrCb (16 to 235) to RGB (0 to 255)

Register	Red/Cr Coeff 1		Red/Cr Coeff 2		Red/Cr Coeff 3		Red/Cr Offset	
Address	0x35	0x36	0x37	0x38	0x39	0x3A	0x3B	0x3C
Value	0x46	0x63	0x04	0xA8	0x00	0x00	0x1C	0x84
Register	Green/Y Coeff 1		Green/Y Coeff 2		Green/Y Coeff 3		Green/Y Offset	
Address	0x3D	0x3E	0x3F	0x40	0x41	0x42	0x43	0x44
Value	0x1C	0xC0	0x04	0xA8	0x1E	0x6F	0x02	0x1E
Register	Blue/Cb Coeff 1		Blue/Cb Coeff 2		Blue/Cb Coeff 3		Blue/Cb Offset	
Address	0x45	0x46	0x47	0x48	0x49	0x4A	0x4B	0x4C
Value	0x00	0x00	0x04	0xA8	0x08	0x11	0x1B	0xAD

Table 20. RGB (0 to 255) to HDTV YCrCb (0 to 255)

Register	Red/Cr Coeff 1		Red/Cr Coeff 2		Red/Cr Coeff 3		Red/Cr Offset	
Address	0x35	0x36	0x37	0x38	0x39	0x3A	0x3B	0x3C
Value	0x08	0x2D	0x18	0x93	0x1F	0x3F	0x08	0x00
Register	Green/Y Coeff 1		Green/Y Coeff 2		Green/Y Coeff 3		Green/Y Offset	
Address	0x3D	0x3E	0x3F	0x40	0x41	0x42	0x43	0x44
Value	0x03	0x68	0x0B	0x71	0x01	0x27	0x00	0x00
Register	Blue/Cb Coeff 1		Blue/Cb Coeff 2		Blue/Cb Coeff 3		Blue/Cb Offset	
Address	0x45	0x46	0x47	0x48	0x49	0x4A	0x4B	0x4C
Value	0x1E	0x21	0x19	0xB2	0x08	0x2D	0x08	0x00

Table 21. RGB (0 to 255) to HDTV YCrCb (16 to 235)

Register	Red/Cr Coeff 1		Red/Cr Coeff 2		Red/Cr Coeff 3		Red/Cr Offset	
Address	0x35	0x36	0x37	0x38	0x39	0x3A	0x3B	0x3C
Value	0x07	0x06	0x19	0xA0	0x1F	0x5B	0x08	0x00
Register	Green/Y Coeff 1		Green/Y Coeff 2		Green/Y Coeff 3		Green/Y Offset	
Address	0x3D	0x3E	0x3F	0x40	0x41	0x42	0x43	0x44
Value	0x02	0xED	0x09	0xD3	0x00	0xFD	0x01	0x00
Register	Blue/Cb Coeff 1		Blue/Cb Coeff 2		Blue/Cb Coeff 3		Blue/Cb Offset	
Address	0x45	0x46	0x47	0x48	0x49	0x4A	0x4B	0x4C
Value	0x1E	0x64	0x1A	0x96	0x07	0x06	0x08	0x00

Table 22. RGB (0 to 255) to SDTV YCrCb (0 to 255)

Register	Red/Cr Coeff 1		Red/Cr Coeff 2		Red/Cr Coeff 3		Red/Cr Offset	
Address	0x35	0x36	0x37	0x38	0x39	0x3A	0x3B	0x3C
Value	0x08	0x2D	0x19	0x27	0x1E	0xAC	0x08	0x00
Register	Green/Y Coeff 1		Green/Y Coeff 2		Green/Y Coeff 3		Green/Y Offset	
Address	0x3D	0x3E	0x3F	0x40	0x41	0x42	0x43	0x44
Value	0x04	0xC9	0x09	0x64	0x01	0xD3	0x00	0x00
Register	Blue/Cb Coeff 1		Blue/Cb Coeff 2		Blue/Cb Coeff 3		Blue/Cb Offset	
Address	0x45	0x46	0x47	0x48	0x49	0x4A	0x4B	0x4C
Value	0x1D	0x3F	0x1A	0x93	0x08	0x2D	0x08	0x00

Table 23. RGB (0 to 255) to SDTV YCrCb (16 to 235)

Register	Red/Cr Coeff 1		Red/Cr Coeff 2		Red/Cr Coeff 3		Red/Cr Offset	
Address	0x35	0x36	0x37	0x38	0x39	0x3A	0x3B	0x3C
Value	0x07	0x06	0x1A	0x1E	0x1E	0xDC	0x08	0x00
Register	Green/Y Coeff 1		Green/Y Coeff 2		Green/Y Coeff 3		Green/Y Offset	
Address	0x3D	0x3E	0x3F	0x40	0x41	0x42	0x43	0x44
Value	0x04	0x1C	0x08	0x11	0x01	0x91	0x01	0x00
Register	Blue/Cb Coeff 1		Blue/Cb Coeff 2		Blue/Cb Coeff 3		Blue/Cb Offset	
Address	0x45	0x46	0x47	0x48	0x49	0x4A	0x4B	0x4C
Value	0x1D	0xA3	0x1B	0x57	0x07	0x06	0x08	0x00

OUTLINE DIMENSIONS

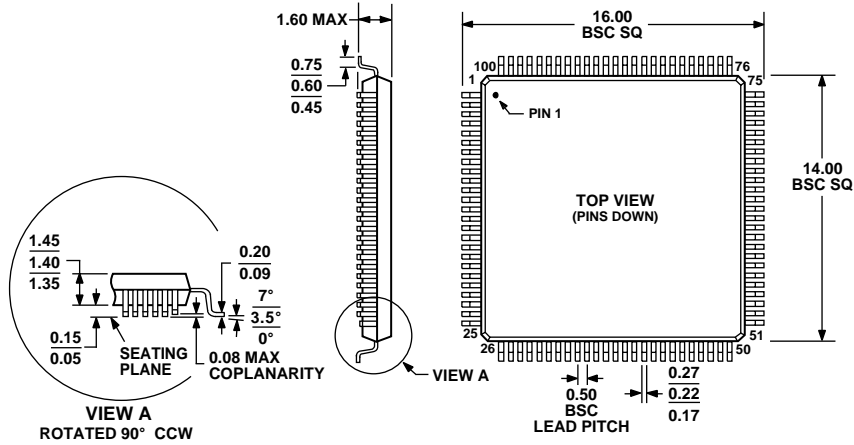

COMPLIANT TO JEDEC STANDARDS MS-026-BED
 Figure 9. 100-Lead Low Profile Quad Flat Package [LQFP]
 (ST-100)
 Dimensions shown in millimeters

ORDERING GUIDE

Model	Max Speeds (MHz)		Temperature Range	Package Description	Package Option
	Analog	Digital			
AD9397KSTZ-100 ¹	100	100	0°C to 70°C	100-Lead Low Profile Quad Flat Package (LQFP)	ST-100
AD9397KSTZ-150 ¹	150	150	0°C to 70°C	100-Lead Low Profile Quad Flat Package (LQFP)	ST-100
AD9397/PCB				Evaluation Board	

¹ Z = Pb-free part.

Looking for pricing, stock, or lifecycle information?

Click below to explore more details on WIN SOURCE:

 [View AD9397KSTZ-150 on WIN SOURCE](#)

 [Analog Devices Inc. Information](#)

Optimize Your Supply Chain with WIN SOURCE Solutions

-  Global Sourcing Solution
-  Obsolete Management
-  Cost Control Management
-  Shortage Management
-  Alternative Solution
-  Excess Inventory Management