



# THE DATASHEET OF DIR9001PWR



# DIR9001 96-kHz, 24-Bit Digital Audio Interface Receiver

## 1 Features

- One-Chip Digital Audio Interface Receiver (DIR) Including Low-Jitter Clock-Recovery System
- Compliant With Digital Audio Interface Standards: IEC60958 (former IEC958), JEITA CPR-1205 (former EIAJ CP-1201, CP-340), AES3, EBU tech3250
- Clock Recovery and Data Decode From Biphasic Input Signal, Generally Called S/PDIF, EIAJ CP-1201, IEC60958, AES/EBU
- Biphasic Input Signal Sampling Frequency ( $f_s$ ) Range: 28 kHz to 108 kHz
- Low-Jitter Recovered System Clock: 50 ps
- Jitter Tolerance Compliant With IEC60958-3
- Selectable Recovered System Clock: 128  $f_s$ , 256  $f_s$ , 384  $f_s$ , 512  $f_s$
- Serial Audio Data Output Formats: 24-Bit I<sup>2</sup>S; MSB-First, 24-Bit Left-Justified; MSB-First 16-, 24-Bit Right-Justified
- User Data, Channel-Status Data Outputs Synchronized With Decoded Serial Audio Data
- No External Clock Required for Decode
- Includes Actual Sampling Frequency Calculator (Needs External 24.576-MHz Clock)
- Function Control: Parallel (Hardware)
- Functions Similar and Pin Assignments Equivalent to Those of DIR1703
- Single Power Supply: 3.3 V (2.7 V to 3.6 V)
- Wide Operating Temperature Range: -40°C to 85°C
- 5 V-Tolerant Digital Inputs
- Package: 28-pin TSSOP, Pin Pitch: 0,65 mm

## 2 Applications

- AV/DVD Receiver, AV Amplifier
- Car or Mobile Audio System
- Digital Television
- Musical Instruments
- Recording Systems
- High-End Audio/Sound Card for PC
- Replacement of DIR1703
- Other Applications Requiring S/PDIF Receiver

## 3 Description

The DIR9001 is a digital audio interface receiver that can receive a 28-kHz to 108-kHz sampling-frequency, 24-bit-data-word, biphasic-encoded signal. The DIR9001 complies with IEC60958-3, JEITA CPR-1205 (Revised version of EIAJ CP-1201), AES3, EBUtech3250, and it can be used in various applications that require a digital audio interface.

The DIR9001 supports many output system clock and output data formats and can be used flexibly in many application systems. As the all functions which the DIR9001 provides can be controlled directly through control pins, it can be used easily in an application system that does not have a microcontroller. Also, as dedicated pins are provided for the channel-status bit and user-data bit, processing of their information can be easily accomplished by connecting with a microcontroller, DSP, or others.

The DIR9001 does not require an external clock source or resonator for decode operation if the internal actual-sampling-frequency calculator is not used. Therefore, it is possible to reduce the cost of a system.

The operating temperature range of the DIR9001 is specified as -40°C to 85°C, which makes it suitable for automotive applications.

### Device Information

PART NUMBER	PACKAGE	BODY SIZE (NOM)
DIR9001	TSSOP (28)	4.40 mm x 9.70 mm

(1) For all available packages, see the orderable addendum at the end of the data sheet.

### Block Diagram

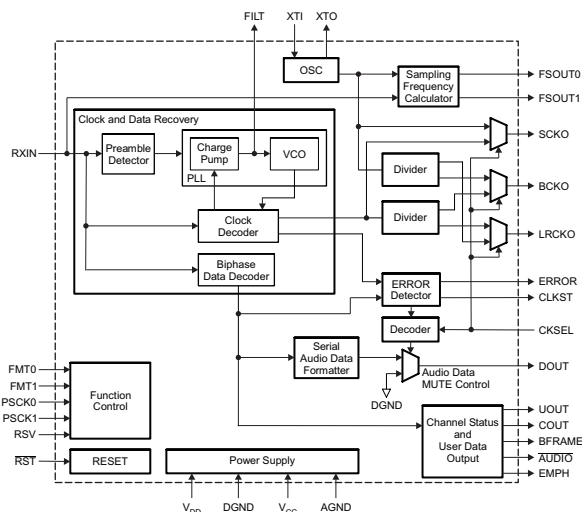

## Table of Contents

<b>1 Features</b> .....	<b>1</b>	8.2 Functional Block Diagram .....	<b>11</b>
<b>2 Applications</b> .....	<b>1</b>	8.3 Feature Description .....	<b>12</b>
<b>3 Description</b> .....	<b>1</b>	8.4 Device Functional Modes .....	<b>20</b>
<b>4 Revision History</b> .....	<b>2</b>	8.5 Programming .....	<b>23</b>
<b>5 Device Comparison Table</b> .....	<b>3</b>	<b>9 Application and Information</b> .....	<b>26</b>
5.1 Differences From DIR1703 .....	<b>3</b>	9.1 Application Information .....	<b>26</b>
<b>6 Pin Configuration and Functions</b> .....	<b>4</b>	9.2 Typical Application .....	<b>27</b>
<b>7 Specifications</b> .....	<b>6</b>	<b>10 Power Supply Recommendations</b> .....	<b>29</b>
7.1 Absolute Maximum Ratings .....	<b>6</b>	<b>11 Layout</b> .....	<b>29</b>
7.2 ESD Ratings .....	<b>6</b>	11.1 Layout Guidelines .....	<b>29</b>
7.3 Recommended Operating Conditions .....	<b>6</b>	11.2 Layout Example .....	<b>30</b>
7.4 Thermal Information .....	<b>7</b>	<b>12 Device and Document Support</b> .....	<b>31</b>
7.5 Electrical Characteristics .....	<b>7</b>	12.1 Community Resources .....	<b>31</b>
7.6 Timing Requirements .....	<b>8</b>	12.2 Trademarks .....	<b>31</b>
7.7 Switching Characteristics .....	<b>9</b>	12.3 Electrostatic Discharge Caution .....	<b>31</b>
7.8 Typical Characteristics .....	<b>10</b>	12.4 Glossary .....	<b>31</b>
<b>8 Detailed Description</b> .....	<b>11</b>	<b>13 Mechanical, Packaging, and Orderable Information</b> .....	<b>31</b>
8.1 Overview .....	<b>11</b>		

## 4 Revision History

### Changes from Original (Dec 2006) to Revision A

**Page**

- Added *Pin Configuration and Functions* section, *ESD Ratings* table, *Feature Description* section, *Device Functional Modes*, *Application and Implementation* section, *Power Supply Recommendations* section, *Layout* section, *Device and Documentation Support* section, and *Mechanical, Packaging, and Orderable Information* section ..... **1**

## 5 Device Comparison Table

### 5.1 Differences From DIR1703

The DIR9001 has many improved functions compared to the DIR1703.

The DIR9001 functions are similar to those of the DIR1703.

The DIR9001 pin assignment is equivalent to that of the DIR1703.

The DIR9001 biphasic input signal decoding function is almost equivalent to that of the DIR1703.

The differences between the DIR9001 and DIR1703 are shown in [Table 1](#).

**Table 1. Main Differences Between DIR1703 and DIR9001**

DIFFERENCE	DIR1703	DIR9001
Operational supply-voltage range	3 V to 3.6 V	2.7 V to 3.6 V
Operation temperature range	–25°C to 85°C	–40°C to 85°C
Package	SSOP-28P, pin pitch: 0.65 mm	TSSOP-28P, pin pitch: 0.65 mm
Clock recovery architecture	SpAct™ feature	Conventional PLL
IEC60958-3 jitter tolerance	Not compliant	Compliant
IEC60958 sampling frequency accuracy	Level II ( $\pm 1000$ ppm)	Level III ( $\pm 12.5\%$ )
Acceptable sampling frequency	32/44.1/48/88.2/96 kHz, $\pm 1500$ ppm	28 kHz to 108 kHz continuous
Biphase input signal level	CMOS level	5-V tolerant TTL level
Connection of loop filter	Between FILT pin and VCC	Between FILT pin and AGND
XTI source clock frequency	One of the following clock sources or resonators must be connected to the XTI pin: 4.069/5.6448/6.144/ 8.192/11.2896/12.288/ 16.384/16.9344/18.432/ 22.5792/24.576-MHz	Optional 24.576-MHz (24.576-MHz clock is only required to use the internal actual-sampling-frequency calculator or use the DIR9001 as a 24.576-MHz clock generator.)
BFRAME H period	$32/f_s$	$8/f_s$
Channel status and user data	Synchronous with LRCK transition	17-BCK delay from LRCK transition
Latest tracked frequency hold	Available	Not available
PLL mode clock at error	Latest tracked frequency	VCO free-running frequency
Clock transition signal out	CKTRNS pin, active H	CLKST pin, active-high
Oscillation amplifier	External feedback resistor (typ. 1 M $\Omega$ )	Internal feedback resistor

The differences between the DIR1703 and DIR9001 I/O pins are shown in [Table 2](#).

**Table 2. The Differences Between DIR1703 and DIR9001 in All I/O Pin**

PIN NO.	DIR1703	DIR9001	DIFFERENCES	DESCRIPTIONS OF DIR9001
1	ADFLG	AUDIO	Pin name only	Channel-status data information of non-audio sample word, active-low
2	BRATE0	FSOUT0	Pin name only	Actual-sampling-frequency calculated result output 0
3	BRATE1	FSOUT1	Pin name only	Actual-sampling-frequency calculated result output 1
4	SCKO	SCKO	Same function	System clock output
5	V <sub>DD</sub>	V <sub>DD</sub>	Same function	Digital power supply, 3.3-V
6	DGND	DGND	Same function	Digital ground
7	XTO	XTO	Same function	Oscillation amplifier output
8	XTI	XTI	Same function	Oscillation amplifier input, or external XTI source clock input
9	CKTRNS	CLKST	CLKST is active-high	Clock change/transition signal output
10	LRCKO	LRCKO	Same function	Audio data latch enable output
11	BCKO	BCKO	Same function	Audio data bit clock output
12	DOUT	DOUT	Same function	16 bit–24 bit decoded serial digital audio data output
13	SCF0	PSCK0	Pin name only	SCKO output frequency selection 0
14	SCF1	PSCK1	Pin name only	SCKO output frequency selection 1
15	CSBIT	COUT	Pin name only	Channel-status data serial output synchronized with LRCKO

**Table 2. The Differences Between DIR1703 and DIR9001 in All I/O Pin (continued)**

PIN NO.	DIR1703	DIR9001	DIFFERENCES	DESCRIPTIONS OF DIR9001
16	URBIT	UOUT	Pin name only	User data serial output synchronized with LRCKO
17	EMFLG	EMPH	Pin name only	Channel-status data Information of pre-emphasis (50 μs/15 μs)
18	BFRAME	BFRAME	Same function	Indication of top block of biphas input signal
19	BRSEL	RSV	Reserved	Reserved, must be connected to DGND
20	DIN	RXIN	Pin name only	Biphase digital data input
21	$\overline{\text{RST}}$	$\overline{\text{RST}}$	Same function	Reset control input, active-low
22	FILT	FILT	Same function	External filter connection terminal. Recommended filter must be connected.
23	AGND	AGND	Same function	Analog ground
24	V <sub>CC</sub>	V <sub>CC</sub>	Same function	Analog power supply, 3.3-V
25	FMT0	FMT0	Same function	Decoded serial digital audio data output format selection 0
26	FMT1	FMT1	Same function	Decoded serial digital audio data output format selection 1
27	UNLOCK	ERROR	Pin name only	Indication of internal PLL or data parity error
28	CKSEL	CKSEL	Same function	Selection of system clock source, Low: PLL (VCO) clock, High: XTI clock

## 6 Pin Configuration and Functions

DIR9001  
(TOP VIEW)



### Pin Functions

PIN		I/O	PULL UP/DOWN	REMARKS	DESCRIPTION
NAME	NO.				
AGND	23	–			Analog ground
$\overline{\text{AUDIO}}$	1	OUT		CMOS	Channel-status data information of non-audio sample word, active-low
BCKO	11	OUT		CMOS	Audio data bit clock output
BFRAME	18	OUT		CMOS	Indication of top block of biphasic input signal
CKSEL	28	IN	Pulldown	5-V tolerant TTL	Selection of system clock source, Low: PLL (VCO) clock, High: XTI clock <sup>(1)</sup>
CLKST	9	OUT		CMOS	Clock change/transition signal output
COUT	15	OUT		CMOS	Channel-status data serial output synchronized with LRCKO
DGND	6	–			Digital ground
DOUT	12	OUT		CMOS	16-bit/24-bit decoded serial digital audio data output
EMPH	17	OUT		CMOS	Channel-status data information of pre-emphasis (50 $\mu$ s/15 $\mu$ s)
ERROR	27	OUT		CMOS	Indication of internal PLL or data parity error
FILT	22	–			External filter connection terminal; must connect recommended filter.
FMT0	25	IN	Pulldown	5-V tolerant TTL	Decoded serial digital audio data output format selection 0 <sup>(1)</sup>
FMT1	26	IN	Pulldown	5-V tolerant TTL	Decoded serial digital audio data output format selection 1 <sup>(1)</sup>
FSOUT0	2	OUT		CMOS	Actual sampling frequency calculated result output 0
FSOUT1	3	OUT		CMOS	Actual sampling frequency calculated result output 1
LRCKO	10	OUT		CMOS	Audio data latch enable output
PSCK0	13	IN	Pulldown	5-V tolerant TTL	PLL source SCKO output frequency selection 0 <sup>(1)</sup>
PSCK1	14	IN	Pulldown	5-V tolerant TTL	PLL source SCKO output frequency selection 1 <sup>(1)</sup>
$\overline{\text{RST}}$	21	IN	Pullup	5-V tolerant TTL	Reset control input, active-low <sup>(2)</sup>
RSV	19	IN	Pulldown		Reserved, must be connected to DGND <sup>(1)</sup>
RXIN	20	IN		5-V tolerant TTL	Biphase digital data input <sup>(3)</sup>
SCKO	4	OUT		CMOS	System clock output
UOUT	16	OUT		CMOS	User data serial output synchronized with LRCKO
V <sub>CC</sub>	24	–			Analog power supply, 3.3-V
V <sub>DD</sub>	5	–			Digital power supply, 3.3-V
XTI	8	IN		CMOS Schmitt-trigger	Oscillation amplifier input, or external XTI source clock input
XTO	7	OUT		CMOS	Oscillation amplifier output

(1) TTL Schmitt-trigger input with internal pulldown (51 k $\Omega$  typical), 5-V tolerant

(2) TTL Schmitt-trigger input with internal pullup (51 k $\Omega$  typical), 5-V tolerant

(3) TTL Schmitt-trigger input, 5-V tolerant.

## 7 Specifications

### 7.1 Absolute Maximum Ratings

 over operating free-air temperature range (unless otherwise noted) <sup>(1)</sup>

		MIN	MAX	UNIT
V <sub>CC</sub>	Supply voltage	-0.3	4	V
V <sub>DD</sub>				
V <sub>CC</sub> to V <sub>DD</sub>	Supply voltage differences	-0.1	0.1	V
AGND to DGND	Ground voltage differences	-0.1	0.1	V
Digital input voltage	Digital input	-0.3	6.5	V
	Digital output	-0.3	(V <sub>DD</sub> + 0.3) < 4	
Analog input voltage	XTI, XTO	-0.3	(V <sub>CC</sub> + 0.3) < 4	V
	FILT	-0.3	(V <sub>CC</sub> + 0.3) < 4	
Input current (any pins except supplies)		-10	10	mA
Ambient temperature under bias		-40	125	°C
Junction temperature			150	°C
Lead temperature (soldering)			260	°C
Package temperature (reflow, peak)			260	°C
T <sub>stg</sub>	Storage temperature	-55	150	°C

(1) Stresses beyond those listed under *Absolute Maximum Ratings* may cause permanent damage to the device. These are stress ratings only and functional operation of the device at these or any other conditions beyond those indicated under *recommended operating conditions* is not implied. Exposure to absolute-maximum-rated conditions for extended periods may affect device reliability.

### 7.2 ESD Ratings

		VALUE	UNIT
V <sub>(ESD)</sub>	Electrostatic discharge	±500	V
		±250	

(1) JEDEC document JEP155 states that 500-V HBM allows safe manufacturing with a standard ESD control process.

(2) JEDEC document JEP157 states that 250-V CDM allows safe manufacturing with a standard ESD control process.

### 7.3 Recommended Operating Conditions

over operating free-air temperature range (unless otherwise noted)

		MIN	NOM	MAX	UNIT
V <sub>CC</sub>	Analog supply voltage	2.7	3.3	3.6	VDC
V <sub>DD</sub>	Digital supply voltage	2.7	3.3	3.6	VDC
Digital input clock frequency	XTI is connected to clock source		24.576		MHz
	XTI is connected to DGND		Not required		MHz
Digital output load capacitance, except SCKO				20	pF
Digital output load capacitance (SCKO)				10	pF
T <sub>A</sub>	Operating free-air temperature	-40		85	°C

## 7.4 Thermal Information

THERMAL METRIC <sup>(1)</sup>		DR9001	
		TSSOP (PW)	UNIT
		28 PINS	
R <sub>θJA</sub>	Junction-to-ambient thermal resistance	81.9	°C/W
R <sub>θJC(top)</sub>	Junction-to-case (top) thermal resistance	22.5	°C/W
R <sub>θJB</sub>	Junction-to-board thermal resistance	40	°C/W
ψ <sub>JT</sub>	Junction-to-top characterization parameter	0.7	°C/W
ψ <sub>JB</sub>	Junction-to-board characterization parameter	39.4	°C/W

(1) For more information about traditional and new thermal metrics, see the *IC Package Thermal Metrics* application report, [SPRA953](#).

## 7.5 Electrical Characteristics

All specifications at T<sub>A</sub> = 25°C, V<sub>DD</sub> = V<sub>CC</sub> = 3.3 V (unless otherwise noted)

PARAMETER		TEST CONDITIONS	MIN	TYP	MAX	UNIT
<b>DIGITAL INPUT/OUTPUT CHARACTERISTICS</b>						
V <sub>IH</sub>	Input logic level <sup>(1)</sup>		0.7 V <sub>DD</sub>		V <sub>DD</sub>	VDC
V <sub>IL</sub>					0.3 V <sub>DD</sub>	
V <sub>IH</sub>	Input logic level <sup>(2)</sup>		2		5.5	VDC
V <sub>IL</sub>					0.8	
V <sub>OH</sub>	Output logic level <sup>(3)</sup>	I <sub>O</sub> = 4 mA	0.85 V <sub>DD</sub>			VDC
V <sub>OL</sub>		I <sub>O</sub> = -4 mA			0.15 V <sub>DD</sub>	
I <sub>IH</sub>	Input leakage current <sup>(4)</sup>	V <sub>IN</sub> = V <sub>DD</sub>		65	100	μA
I <sub>IL</sub>		V <sub>IN</sub> = 0 V	-10		10	
I <sub>IH</sub>	Input leakage current <sup>(5)</sup>	V <sub>IN</sub> = V <sub>DD</sub>	-10		10	μA
I <sub>IL</sub>		V <sub>IN</sub> = 0 V	-100	-65		
I <sub>IH</sub>	Input leakage current <sup>(6)</sup>	V <sub>IN</sub> = V <sub>DD</sub>	-10		10	μA
I <sub>IL</sub>		V <sub>IN</sub> = 0 V	-10		10	
<b>BIPHASE SIGNAL INPUT AND PLL</b>						
Jitter tolerance — (IEC60958-3)		IEC60958-3 (2003-01)	Compliant			
<b>RECOVERED CLOCK AND DATA</b>						
Serial audio data width			16		24	Bit
SCKO jitter		f <sub>S</sub> = 48 kHz, SCKO = 256 f <sub>S</sub> , measured periodic		50	100	ps rms
<b>XTI SOURCE CLOCK</b>						
Frequency accuracy		XTI is connected to clock source	-100		100	ppm
<b>POWER SUPPLY AND SUPPLY CURRENT</b>						
V <sub>CC</sub>	Operation voltage range		2.7	3.3	3.6	VDC
V <sub>DD</sub>			2.7	3.3	3.6	
I <sub>CC</sub>	Supply current <sup>(7)</sup>	f <sub>S</sub> = 96 kHz, PLL locked, XTI connected to DGND		6	8.3	mA
		f <sub>S</sub> = 96 kHz, PLL locked, XTI connected to 24.576-MHz resonator		6	8.3	mA
		RXIN = H or L, XTI = L, $\overline{\text{RST}}$ = L		130		μA

(1) CMOS compatible input: XTI (not 5-V tolerant)

(2) 5-V tolerant TTL inputs: RXIN, FMT0, FMT1, PSCK0, PSCK1, CKSEL,  $\overline{\text{RST}}$ , RSV

(3) CMOS outputs: XTO, SCKO, BCKO, LRCKO, DOUT, UOUT, COUT, BFRAME, ERROR, CLKST,  $\overline{\text{AUDIO}}$ , EMPH, FSOUT0, FSOUT1

(4) Internal pulldowns: FMT0, FMT1, PSCK0, PSCK1, CKSEL, RSV

(5) Internal pullup:  $\overline{\text{RST}}$

(6) No internal pullup and pulldown: RXIN, XTI

(7) No load connected to SCKO, BCKO, LRCKO, DOUT, COUT, VOUT, BFRAME, FSOUT0, FSOUT1, CLKST, ERROR, EMPH,  $\overline{\text{AUDIO}}$

## Electrical Characteristics (continued)

 All specifications at  $T_A = 25^\circ\text{C}$ ,  $V_{DD} = V_{CC} = 3.3\text{ V}$  (unless otherwise noted)

PARAMETER		TEST CONDITIONS	MIN	TYP	MAX	UNIT
$I_{DD}$	Supply current <sup>(7)</sup>	$f_S = 96\text{ kHz}$ , PLL locked, XTI connected to DGND		6	8.3	mA
		$f_S = 96\text{ kHz}$ , PLL locked, XTI connected to 24.576-MHz resonator		9	12.4	mA
		RXIN = H or L, XTI = L, $\overline{\text{RST}} = \text{L}$		72		$\mu\text{A}$
$P_D$	Power dissipation <sup>(7)</sup>	$f_S = 96\text{ kHz}$ , PLL locked, XTI connected to DGND		40	55	mW
		$f_S = 96\text{ kHz}$ , PLL locked, XTI connected to 24.576-MHz resonator		50	68	mW
		RXIN = H or L, XTI = L, $\overline{\text{RST}} = \text{L}$		0.67		mW
<b>TEMPERATURE RANGE</b>						
$T_A$	Operation temperature range		-40		85	$^\circ\text{C}$
$\theta_{JA}$	Thermal resistance	28-pin T-SSOP		105		$^\circ\text{C/W}$

## 7.6 Timing Requirements

 All specifications at  $T_A = 25^\circ\text{C}$ ,  $V_{DD} = V_{CC} = 3.3\text{ V}$  (unless otherwise noted)

		MIN	NOM	MAX	UNIT
<b>BIPHASE SIGNAL INPUT AND PLL</b>					
Input sampling frequency range		28		108	kHz
<b>XTI SOURCE CLOCK</b>					
XTI source clock frequency	XTI is connected to clock source	24.576			MHz
	XTI is connected to DGND	Not required			
XTI input-clock duty cycle	XTI is connected to clock source	45%		55%	
<b>CLKST</b>					
$t_{\text{CLKST}}$	CLKST pulse duration, high	4		20	$\mu\text{s}$
<b>LATENCY</b>					
$t_{\text{LATE}}$	LRCKO/DOUT latency	See <a href="#">Figure 14</a>		$3/f_S$	s
<b>DATA OUTPUT<sup>(1)</sup></b>					
$t_{\text{SCY}}$	System clock pulse cycle time	18			ns
$t_{\text{SCBC}}$	Delay time of SCK rising edge to BCK rising edge	4	8	15	ns
$t_{\text{CKLR}}$	Delay time of BCKO falling edge to LRCKO valid	-5 0.5 0.5			ns
$t_{\text{BCY}}$	BCKO pulse cycle time	$1/64f_S$			s
$t_{\text{BCH}}$	BCKO pulse duration, HIGH	60			ns
$t_{\text{BCL}}$	BCKO pulse duration, LOW	60			ns
$t_{\text{BCDO}}$	Delay time of BCKO falling edge to DOUT valid	-5	1	5	ns
$t_r$	Rising time of all signals				10 ns
$t_f$	Falling time of all signals				10 ns

(1) Load capacitance of the LRCKO, BCKO, and DOUT pins is 20 pF. DOUT, LRCKO, and BCKO are synchronized with SCKO.

## 7.7 Switching Characteristics

All specifications at  $T_A = 25^\circ\text{C}$ ,  $V_{DD} = V_{CC} = 3.3\text{ V}$  (unless otherwise noted)

PARAMETER	TEST CONDITIONS	MIN	TYP	MAX	UNIT
<b>BIPHASE SIGNAL INPUT AND PLL</b>					
PLL lock-up time	From biphas signal detection to error-out release (ERROR = L)			100	ms
<b>RECOVERED CLOCK AND DATA</b>					
SCKO frequency	128 $f_S$	3.584		13.824	MHz
	256 $f_S$	7.168		27.648	
	384 $f_S$	10.752		41.472	
	512 $f_S$	14.336		55.296	
BCKO frequency	64 $f_S$	1.792		6.912	MHz
LRCKO frequency	$f_S$	28		108	kHz
SCKO duty cycle		45%		55%	

### 7.8 Typical Characteristics

Oscillation amplifier operating with crystal; 1-kHz, 0-dB, sine-wave data; no load

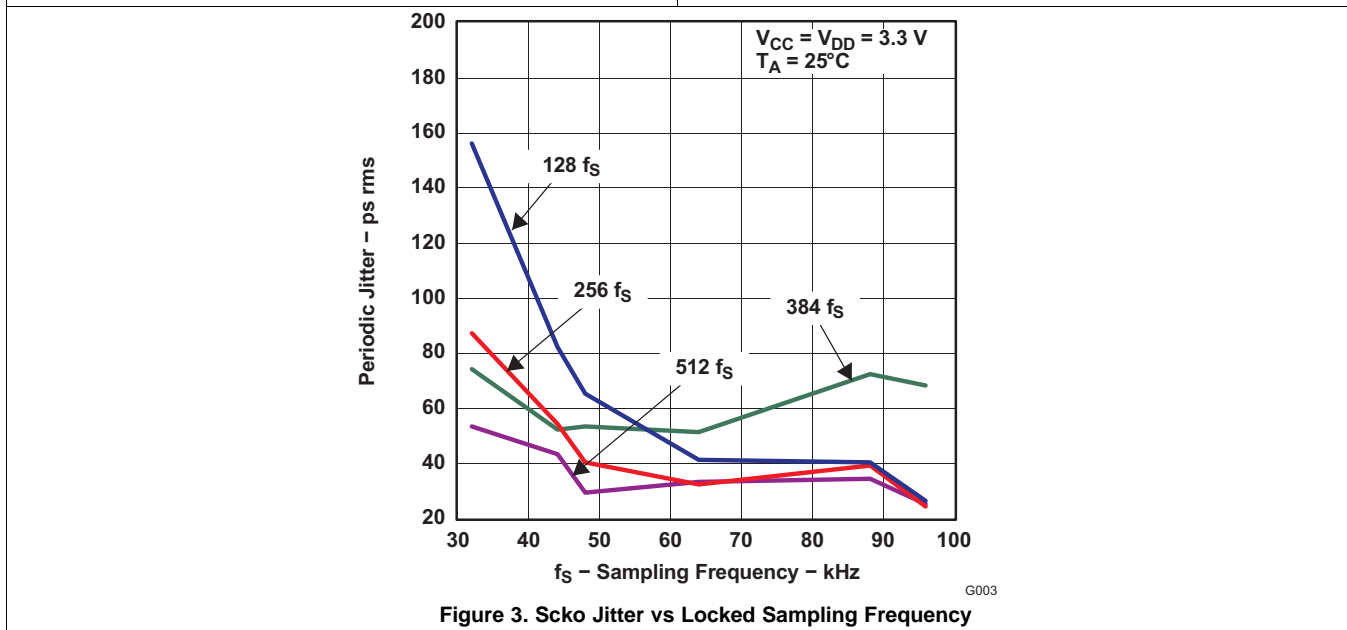
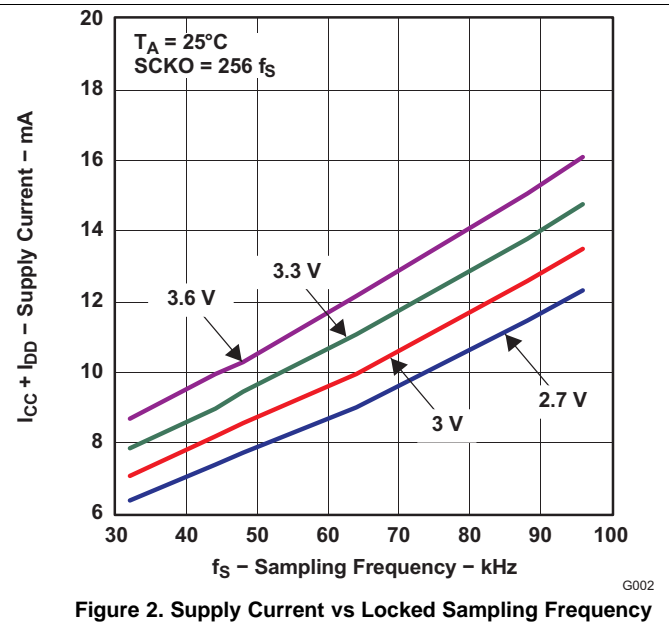
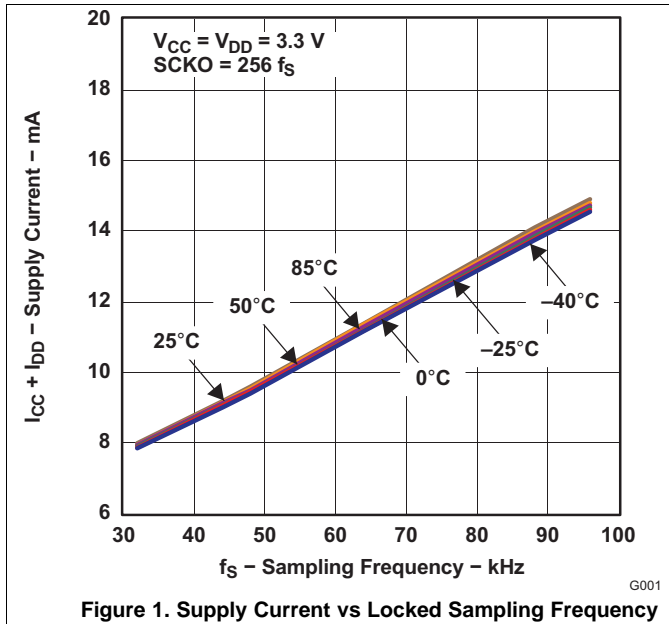

## 8 Detailed Description

### 8.1 Overview

The DIR9001 is a digital audio interface receiver that can receive a 28-kHz to 108-kHz sampling frequency, 24-bit-data-word, biphas-encoded signal and output a serial audio signal. The DIR9001 complies with the jitter specification IEC60958-3, JEITA CPR1205 (Revised version of EIAJ CP-1201), AES3, EBUtech3250, and it can be used in various applications that require a digital audio interface.

The DIR9001 supports MSB-first PCM data output in 24-bit I2S, 24-bit left justified, 24-bit right justified, or 16-bit right justified form. Sampling rates of 32 kHz, 44.1 kHz, 48 kHz, 88.2 kHz, and 96 kHz are supported on the serial audio data output when in PLL mode. All functions which the DIR9001 provides can be controlled directly through control pins. This means that they can be pulled high or low for full operation of the DIR9001 without a microcontroller. A microcontroller can also be used to drive the function pins to provide an adaptable system. Also, as dedicated pins are provided for the channel-status bit and user-data bit, processing of their information can be easily accomplished by connecting with a microcontroller, DSP, and so on.

The DIR9001 can derive a system clock by recovering the source's clock from the biphas input signal. Therefore, the DIR9001 does not require an external clock source or resonator for decode operation if the internal actual-sampling-frequency calculator is not used which in turn can reduce the system cost. The serial audio data output can also be driven by an external source such as a crystal or ceramic resonator.

The operating temperature range of the DIR9001 is specified as  $-40^{\circ}\text{C}$  to  $85^{\circ}\text{C}$ , which makes it suitable for automotive applications.

### 8.2 Functional Block Diagram

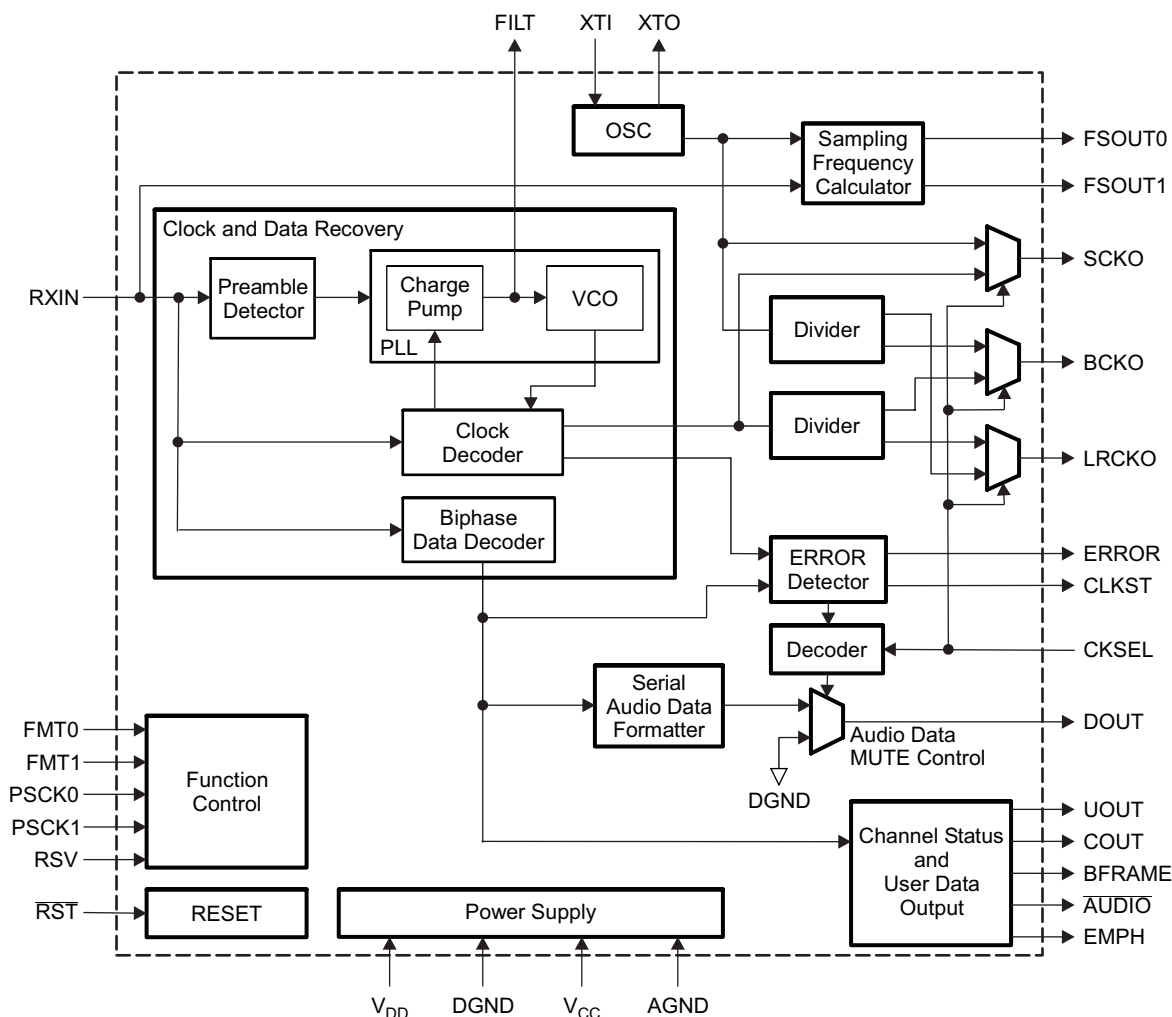

## 8.3 Feature Description

### 8.3.1 Acceptable Biphase Input Signal and Biphase Input Pin (RXIN)

The DIR9001 can decode the biphase signal format which is specified in one of the following standards. Generally, these following standards may be called Sony/Philips digital interface format (S/PDIF) or AES/EBU.

- IEC60958 (revised edition of former IEC958)
- JEITA CPR-1205 (revised edition of former EIAJ CP-1201, CP-340)
- AES3
- EBU tech3250

The sampling frequency range and data word length which DIR9001 can decode is as follows:

- Sampling frequency range is 28 kHz to 108 kHz.
- Maximum audio sample word length is 24-bit.

Note of others about the biphase input signal.

- The capture ratio of the built-in PLL complies with level III of sampling frequency accuracy ( $\pm 12.5\%$ ), which is specified in IEC60958-3.
- The jitter tolerance of the DIR9001 complies with IEC60958-3.
- The PLL may also lock in outside of the specified sampling-frequency range, but extended range is not assured.

Notice about the signal level and transmission line of the biphase input signal.

- The signal level and the transmission line (optical, differential, single-ended) are different in each standard.
- The biphase input signal is connected to the RXIN pin of the DIR9001.
- The RXIN pin has a 5-V tolerant TTL-level input.
- An optical receiver module (optical to electric converter) such as TOSLINK, which is generally used in consumer applications, is connected directly to the RXIN pin without added external components.
- The output waveform of the optical receiver module varies depending on the characteristics of each product type, so a dumping resistor or buffer amplifier might be required between the optical receiver module output and the DIR9001 input. Careful handling is required if the optical receiver module and the DIR9001 are separated by a long distance.
- The DIR9001 needs an external amplifier if it is connected to a coaxial transmission line.
- The DIR9001 needs an external differential to single-ended converter, attenuator, etc., for general consumer applications if non-optical transmission line is used.

### 8.3.2 System Reset

The DIR9001 reset function is controlled by an external reset pin,  $\overline{\text{RST}}$ .

The reset operation must be performed during the power-up sequence as shown in Figure 4. Specifically, the DIR9001 requires reset operation with a 100-ns period after the supply voltage rises above 2.7 V.

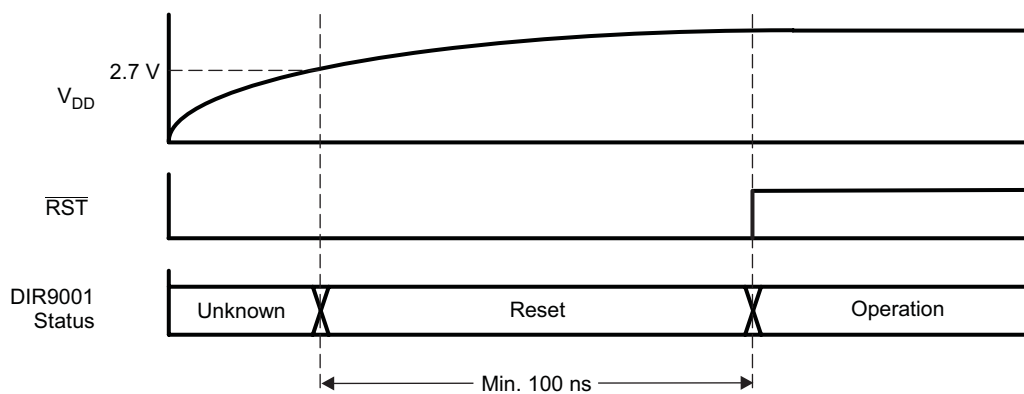

**Figure 4. Required System Reset Timing**

## Feature Description (continued)

The state of each output pins during reset is shown in [Table 3](#).

**Table 3. Output-Pin States During Reset Period**

CLASSIFICATION	PIN NAME	WHILE $\overline{RST} = L$
Clock	BCKO	L
	LRCKO	L
	SCKO	L
Data	DOUT	L
Flag and status	AUDIO	L
	BFRAME	L
	CLKST	L
	COUT	L
	EMPH	L
	ERROR	H
	FSOUT0	L
	FSOUT1	L
Oscillation amplifier	XTO	Output

### 8.3.3 Clock Description

#### 8.3.3.1 System Clock Source

DIR9001 has the following two clock sources for the system clock.

- PLL source (128  $f_S$ , 256  $f_S$ , 384  $f_S$ , 512  $f_S$  are available, recovered by built-in PLL)
- XTI source (One 24.576-MHz resonator or external clock source is required.)

Two clock sources are used for the following purpose.

- PLL source: Recovered system clock from the biphasic input signal
- XTI source: Clock source for peripheral devices (for example, A/D converter, microcontroller, etc.)  
Measurement reference clock for the internal actual-sampling-frequency calculator

Description of PLL clock source

- The PLL clock source is the output clock of built-in PLL (including VCO).
- The PLL clock source frequency is selectable from 128  $f_S$ , 256  $f_S$ , 384  $f_S$ , 512  $f_S$  by PSCK[1:0].
- When the PLL is in the locked condition, the PLL clock source is the clock recovered from the biphasic input signal.
- When PLL is in the unlocked condition, the PLL clock source is the built-in free-running clock of the VCO.
- The frequency of the PLL clock source in the unlocked condition is not constant.  
(The VCO free-running frequency is dependent on supply voltage, temperature, and variations in the die's wafer.)

Description of XTI clock source

- The XTI clock source is not used to recover the clock and decode data from the biphasic input signal.
- Therefore, if the DIR9001 is used only for recovering the clock and decoding data from the biphasic input signal, an XTI clock source is not required. In this case, the XTI pin must be connected to the DGND pin.  
(The DIR9001 does not have a selection pin for using an XTI clock source or not using one.)

The selection method of clock source

- The output clock is selected from two clock sources by the level of the CKSEL pin.
- The selection of the system clock source depends only on the input level of CKSEL pin.
- CKSEL = L setting is required for recovering the clock and decoding data from biphasic input.
- CKSEL = H setting is required for XTI clock source output.
- The continuity of clock during the clock source transition between the XTI source and the PLL source is not

assured.

Method of automatic clock source selection (CLOCK SOURCE MODE: AUTO)

- This method enables selection of the clock source automatically, using the DIR9001 ERROR status. The PLL source clock is output when ERROR = L; the XTI source is output when ERROR = H.
- To enable automatic clock source selection, the CKSEL pin must be connected to the ERROR pin.
- If XTI clock source is needed during the ERROR period, this method is recommended.
- Because the clock source during ERROR status is XTI, if an XTI clock source is not provided to the XTI pin, then SCKO, BCKO, and LRCKO are not output during the ERROR period.

The relationship between the clock/data source and the combination of CKSEL pin and PLL status inputs is shown in [Table 12](#).

The clock tree system is shown in [Figure 5](#).

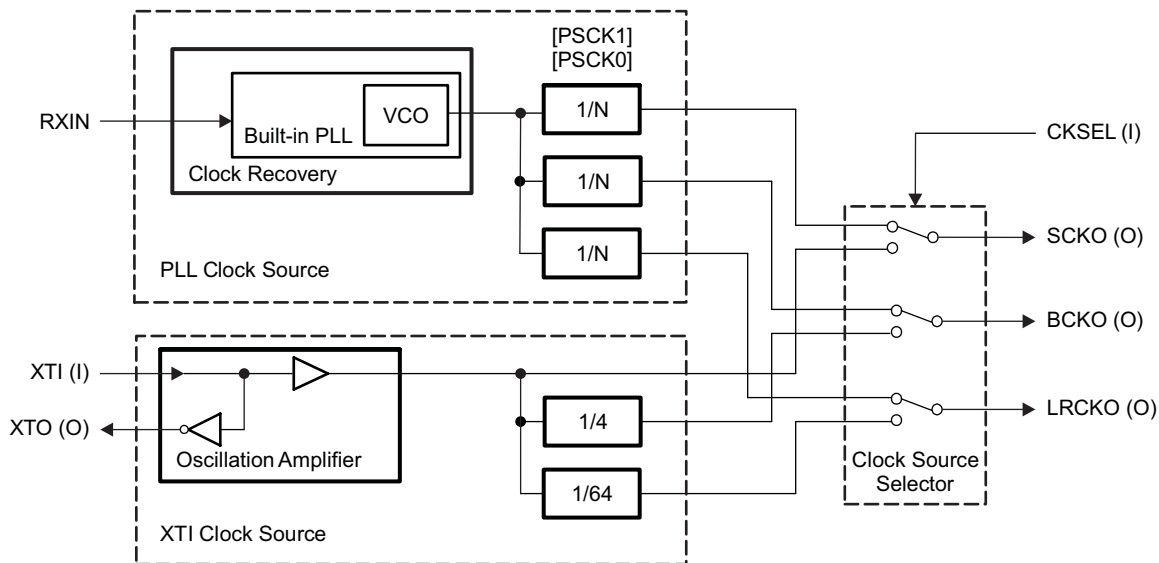

**Figure 5. Clock Tree Diagram**

### 8.3.4 PLL Clock Source (Built-In PLL and VCO) Description

The DIR9001 has on-chip PLL (including VCO) for recovering the clock from the biphasic input signal.

The clock that is output from the built-in VCO is defined as the PLL clock source.

In the locked state, the built-in PLL generates a system clock that synchronizes with the biphasic input signal.

In the unlocked state, the built-in PLL (VCO) generates a free-running clock. (The frequency is not constant.)

The PLL can support a system clock of  $128 f_s$ ,  $256 f_s$ ,  $384 f_s$ , or  $512 f_s$ , where  $f_s$  is the sampling frequency of the biphasic input signal.

The system clock frequency of the PLL is selected by PSCK[1:0].

The DIR9001 can decode a biphasic input signal through its sampling-frequency range of 28 kHz to 108 kHz, independent of the setting of PSCK[1:0].

Therefore, the DIR9001 can decode a biphasic input signal with a sampling frequency from 28 kHz to 108 kHz at all settings of PSCK[1:0]

The relationship between the PSCK[1:0] selection and the output clock (SCKO, BCKO, LRCKO) from the PLL source is shown in [Table 4](#).

**Table 4. SCKO, BCKO, and LRCKO Frequencies Set by PSCK[1:0]**

PSCK[1:0] SETTING		OUTPUT CLOCK FROM PLL SOURCE		
PSCK1	PSCK0	SCKO	BCKO	LRCKO
L	L	128 $f_s$	64 $f_s$	$f_s$
L	H	256 $f_s$	64 $f_s$	$f_s$
H	L	384 $f_s$	64 $f_s$	$f_s$
H	H	512 $f_s$	64 $f_s$	$f_s$

In PLL mode (CKSEL = L), output clocks (SCKO, BCKO, LRCKO) are generated from the PLL source clock.

The relationship between frequencies of LRCKO, BCKO, and SCKO at different sampling frequencies  $f_s$  of the biphase input signal are shown in [Table 5](#).

**Table 5. Output Clock Frequency in PLL Locked State (CKSEL = L)**

LRCKO $f_s$	BCKO 64 $f_s$	SCKO (DEPENDING ON PSCK[1:0] SETTING)			
		128 $f_s$	256 $f_s$	384 $f_s$	512 $f_s$
32 kHz	2.048 MHz	4.096 MHz	8.192 MHz	12.288 MHz	16.384 MHz
44.1 kHz	2.8224 MHz	5.6448 MHz	11.2896 MHz	16.9344 MHz	22.5792 MHz
48 kHz	3.072 MHz	6.144 MHz	12.288 MHz	18.432 MHz	24.576 MHz
88.2 kHz	5.6448 MHz	11.2896 MHz	22.5792 MHz	33.8688 MHz	45.1584 MHz
96 kHz	6.144 MHz	12.288 MHz	24.576 MHz	36.864 MHz	49.152 MHz

### 8.3.5 Required PLL Loop Filter Description

The DIR9001 incorporates a PLL for generating a clock synchronized with the biphase input signal.

The built-in PLL requires an external loop filter, which is specified as follows.

Operation and performance is assured for recommended filter components R1, C1, and C2.

Notes about Loop Filter Components and Layout

- The resistor and capacitors which comprise the filter should be located and routed as close as possible to the DIR9001.
- A carbon film resistor or metal film resistor, with tolerance less than 5%, is recommended.
- Film capacitors, with tolerance is less than 5%, is recommended.
- If ceramic capacitors are used for C1 and C2, parts with a low voltage coefficient and low temperature coefficient, such as CH or C0G, are recommended.
- The external loop filter must be placed on FILT pins.
- The GND node of the external loop filter must be directly connected with the AGND pin of the DIR9001; it must be not combined with other signals.

The configuration of external loop filter and the connection with the DIR9001 is shown in [Figure 6](#).

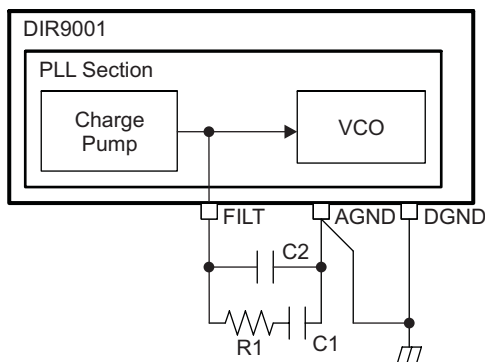

**Figure 6. Loop Filter Connection**

The recommended values of loop filter components is shown in [Table 6](#).

**Table 6. Recommended Value of Loop Filter Components**

REF. NO.	RECOMMENDED VALUE	PARTS TYPE	TOLERANCE
R1	680 Ω	Metal film or carbon	≤5%
C1	0.068 μF	Film or ceramic (CH or C0G)	≤5%
C2	0.0047 μF	Film or ceramic (CH or C0G)	≤5%

**8.3.6 XTI Clock Source and Oscillation Amplifier Description**

This clock, driven by the built-in oscillation amplifier or input into the XTI pin from an external clock, is defined as the XTI source. A 24.576-MHz fundamental resonator or external 24.576-MHz clock is used as the XTI source.

The DIR9001 requires an XTI source for following purposes:

- The measurement reference clock of actual-sampling-frequency calculator
- The clock source for the XTI source mode (CKSEL = H setting)  
(That is, the DIR9001 does not require an XTI source if it is only decoding the biphasic input signal.)

The XTI clock source is supplied in one of the following two ways; the details are described in [Figure 7](#).

- Setting up an oscillation circuit by connecting a resonator with the built-in amplifier
- Applying a clock from an external oscillator circuit or oscillator module

To set up an oscillation circuit by connecting a resonator with the built-in amplifier:

- Connect a 24.576-MHz resonator between the XTI pin and XTO pin.
- The resonator should be a fundamental-mode type.
- A crystal resonator or ceramic resonator can be used.
- The load capacitor  $C_{L1}$ ,  $C_{L2}$ , and the current-limiting resistor  $R_d$  depend on the characteristics of the resonator.
- No external feedback resistor between the XTI pin and XTO pin is required, as an appropriate resistor is incorporated in the device.
- No load other than the resonator is allowed on the XTO pin.

To connect an external oscillator circuit or oscillator module:

- Provide a 24.576-MHz clock on the XTI pin
- Note that the XTI pin is not 5-V tolerant; it is simple CMOS input.
- The XTO pin must be open.

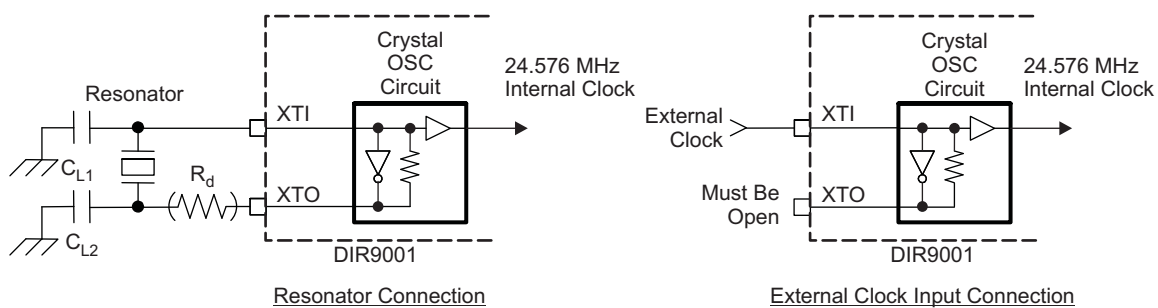

**Figure 7. XTI and XTO Connection Diagram**

Description of oscillation amplifier operation:

- The built-in oscillation amplifier is always working.
- If the XTI source clock is not used, then the XTI pin must be connected to DGND.
- For reducing power dissipation, it is recommended to not use the XTI source clock.

In XTI mode (CKSEL = H), output clocks (SCKO, BCKO, LRCKO) are generated from XTI source clock.

The relation between output clock frequency (SCKO, BCKO, LRCKO) and the XSCK pin setting in XTI source mode is shown in [Table 7](#).

**Table 7. SCKO, BCKO, LRCKO Output Frequency at XTI Mode**

XTI FREQUENCY	OUTPUT CLOCK FREQUENCY IN XTI SOURCE MODE (CKSEL = H)		
	SCKO	BCKO	LRCKO
24.576 MHz	24.576 MHz	6.144 MHz	96 kHz

### 8.3.7 Channel-Status Data and User Data Serial Outputs

The DIR9001 can output channel-status data and user data synchronized with audio data from the biphasic input signal.

Each output data has its own dedicated output pin.

**Channel-status data** (C, hereinafter) is output through COUT pin.

**User data** (U, hereinafter) is output through UOUT pin.

The C and U outputs are synchronized with LRCKO recovered from the biphasic input signal.

The polarity of LRCKO recovered from the biphasic input signal depends on FMT[1:0] setting.

For detecting the top of the block of channel-status data or user data, the BFRAME pin is provided.

The BFRAME pin outputs a high level for an 8-LRCK period if the preamble *B* is detected in the received biphasic signal.

In processing these data by a microcontroller or register circuit, LRCKO is used as the data input clock, and the output pulse on the BFRAME pin is used as the top-of-block signal.

The relationship among LRCKO, BFRAME, DOUT, COUT, and UOUT is shown in Figure 8.

When in the XTI mode and the PLL-locked state, COUT and UOUT output L.

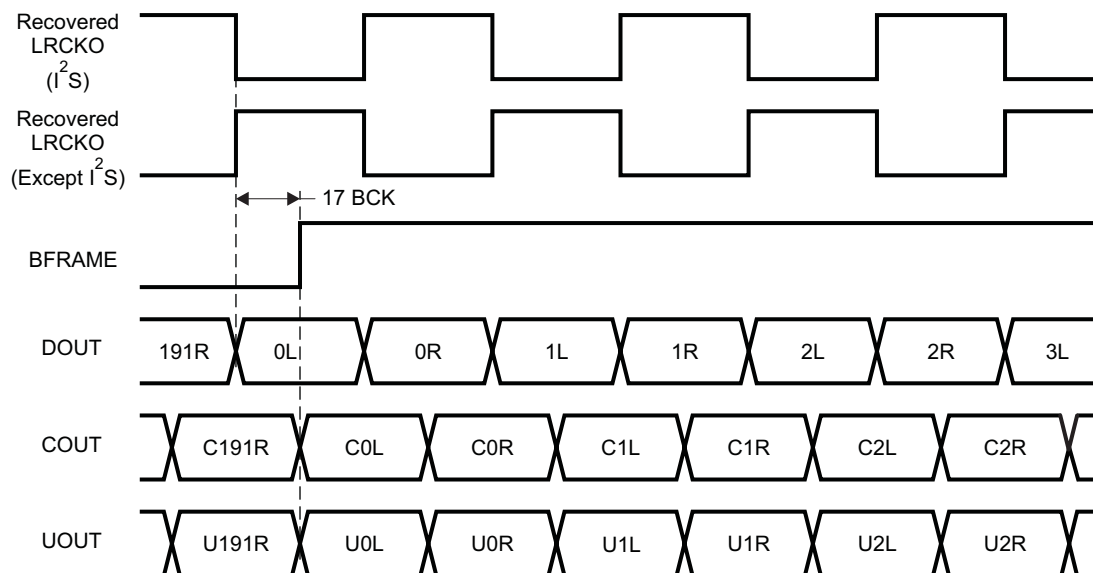

NOTE: The numbers 0 through 191 of DOUT, COUT, and UOUT indicate frame numbers of the biphasic input.

**Figure 8. LRCKO, DOUT, BFRAME, COUT, UOUT Output Timing**

### 8.3.8 Channel-Status Data Information Output Terminal

The DIR9001 can output part of the channel-status information (bit 1, bit 3) through two dedicated pins,  $\overline{\text{AUDIO}}$  and EMPH.

The channel-status information which can be output from dedicated pins is limited to information from the L-channel.

If channel-status information other than AUDIO or EMPH is required, or information from the R-channel, then the channel-status data on the COUT pin, which is synchronized with biphasic input signal, can be used.

These outputs are synchronized with the top of block.

The information that can be output through the dedicated pins is shown as follows.

### 8.3.8.1 **AUDIO Pin**

This is the output pin for the audio sample word information of the channel-status data bit 1.

**Table 8. Audio Sample Word Information**

AUDIO	DESCRIPTION
L	Audio sample word represents linear PCM samples.
H	Audio sample word is used for other purposes.

### 8.3.8.2 **EMPH Pin**

This is the output pin for the emphasis information of the channel-status data bit 3.

**Table 9. Pre-Emphasis Information**

EMPH	DESCRIPTION
L	Two audio channels without pre-emphasis
H	Two audio channels with 50 $\mu$ s / 15 $\mu$ s pre-emphasis

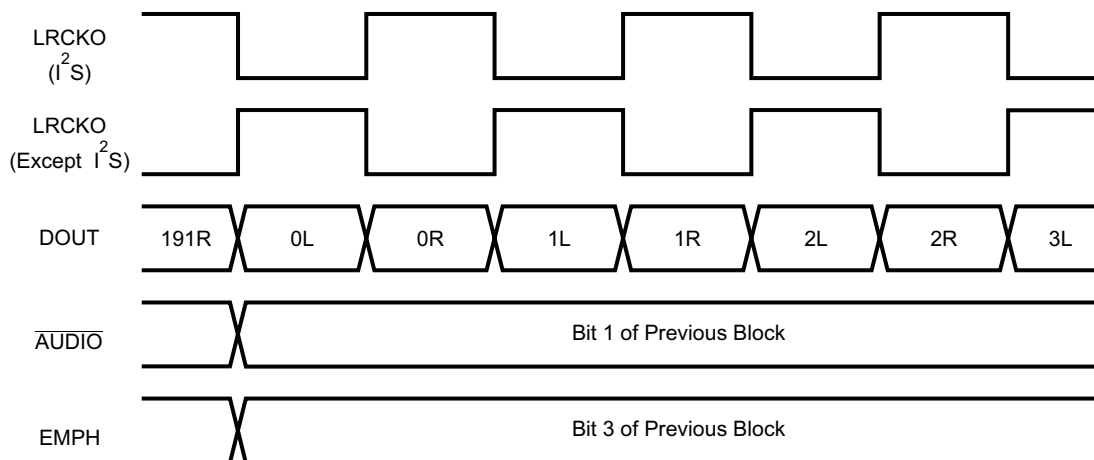

NOTE: The numbers 0 through 191 of DOUT indicate frame numbers of the biphase input.

**Figure 9. AUDIO and EMPH Output Timing**

## 8.3.9 Errors And Error Processing

### 8.3.9.1 **Error Output Description**

Error detection and data error processing for PLL errors

- PLL responds with unlock for data in which the rule of biphase encoding is lost (biphase error and frame-length error).
- PLL responds with unlock for data in which the preamble B, M, W can not be detected.

Error processing function and error output pins

- The DIR9001 has a data error detect function and an error output pin, ERROR.
- The ERROR pin is defined as the logical OR of data error and parity error detection.
- The ERROR rising edge is synchronized with CLKST.
- The ERROR falling edge is synchronized with LRCK.

The relationship between data error and detected parity error is shown in [Figure 10](#).

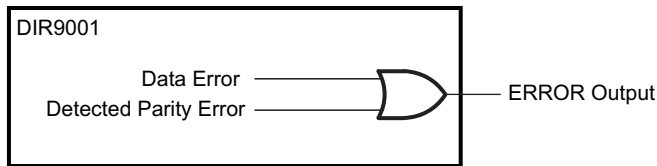

Figure 10. ERROR Output

The state of the ERROR pin and the details of error are shown in Table 10.

Table 10. State of ERROR Output Pin

ERROR	DESCRIPTION
L	Lock state of PLL and nondetection of parity error
H	Unlock state of PLL or detection of parity error

### 8.3.9.2 Parity Error Processing

Error detection and error processing for parity errors

- For PCM data, interpolation processing by previous data is performed.
- For non-PCM data, interpolation is not performed and data is directly output with no processing. (Non-PCM data is data with channel-status data bit 1 = 1.)

The processing for parity error occurrence is shown in Figure 11.

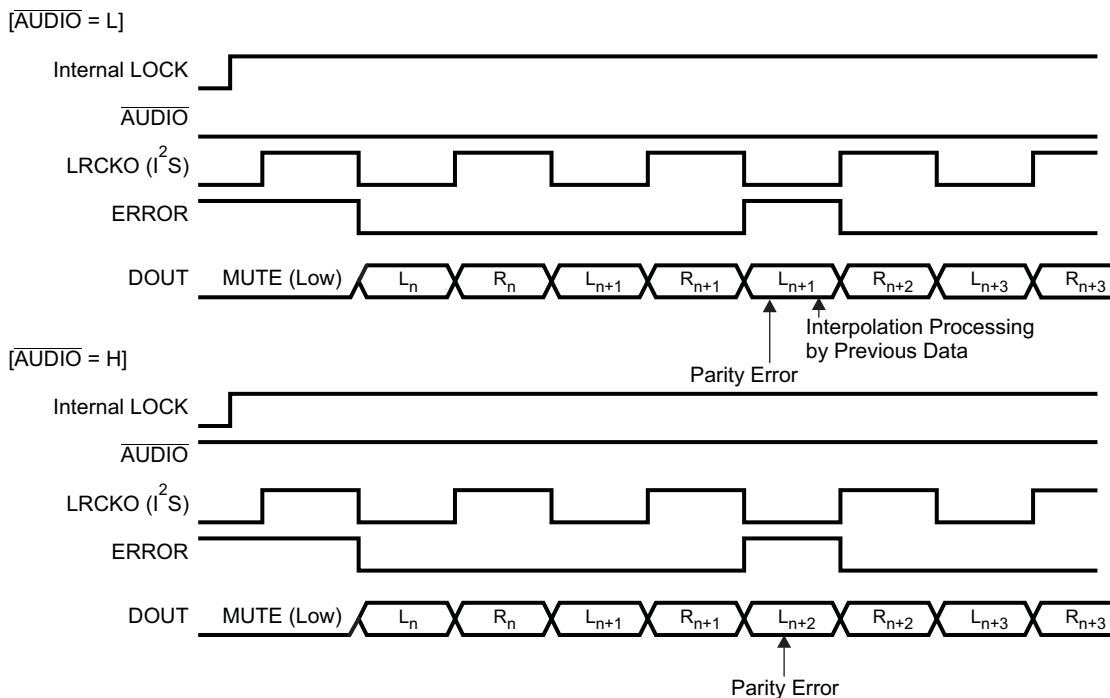

Figure 11. Processing for Parity Error Occurrence

### 8.3.9.3 Other Error

Error for sampling frequency change: A rapid continuous change or a discontinuous change of the input sampling frequency causes the PLL to lose lock.

### 8.3.10 Calculation of Actual Sampling Frequency

The DIR9001 calculates the actual sampling frequency of the biphase input signal and outputs its result through dedicated pins.

To use this function, a 24.576-MHz clock source must be supplied to the XTI pin. The 24.576-MHz clock is used as a measurement reference clock to calculate the actual sampling frequency.

If the XTI pin is connected to DGND, calculation of the actual sampling frequency is not performed.

If there is an error in the XTI clock frequency, the calculation result and range are shifted correspondingly.

This output is the result of calculating the sampling frequency, it is not the sampling frequency information of the channel-status data (bit 24–bit 27).

The sampling frequency information of the channel-status data (bit 24–bit 27) is not output through these pins.

The calculation result is decoded into 2-bit data, which is output on the FSOUT[1:0] pins.

If the PLL is locked but the sampling frequency is out-of-range, or if the PLL is unlocked, FSOUT[1:0] = HL is output to indicate an abnormality.

When the XTI source clock is not supplied before power on, FSOUT [1:0] always outputs LL.

When the XTI source clock is stopped, the  $f_s$  calculator holds the last value of the  $f_s$  calculator result.

If XTI source clock is supplied, the  $f_s$  calculator resumes operation.

The calculated value is held until reset.

The relationship between the FSOUT[1:0] outputs and the range of sampling frequencies is shown in [Table 11](#).

**Table 11. Calculated Sampling Frequency Output**

NOMINAL $f_s$	ACTUAL SAMPLING FREQUENCY RANGE	CALCULATED SAMPLING FREQUENCY OUTPUT	
		FSOUT1	FSOUT0
Out of range	Out of range or PLL unlocked	H	L
32 kHz	31.2 kHz–32.8 kHz	H	H
44.1 kHz	43 kHz–45.2 kHz	L	L
48 kHz	46.8 kHz–49.2 kHz	L	H

## 8.4 Device Functional Modes

### 8.4.1 Operation Mode and Clock Transition Signal Out

#### 8.4.1.1 Operation Mode

The DIR9001 has the following three operation modes.

These modes are selected by the connection of the CKSEL pin.

- PLL MODE: For demodulating a biphase input signal; always outputs PLL source clock
- XTI MODE: For clock generator; always outputs XTI source clock
- AUTO MODE: Automatic clock source selection; output source depends on ERROR pin.

Notes about operation mode selection:

- Normally, the PLL mode: CKSEL = L is selected to decode a biphase input signal.
- The XTI mode is a mode that supplies the XTI source clock to peripheral devices (A/D converters, etc); therefore, recovered clock and decoded data is not output.
- When the XTI source is not used, an XTI source is not required. In this case, clocks are not output in the XTI mode.
- At the time of XTI mode selection, biphase decode function continues to operate. Therefore, the biphase input status (ERROR) and the result of the sampling frequency calculator (a required XTI source for operation), are always monitored. That is, the following output pins: ERROR, BFRAME, FSOUT[1:0], CLKST, AUDIO and EMPH are always enabled.

Device Functional Modes (continued)

The details of these three modes are given in Table 12.

Table 12. Operation Mode and Clock Source

OPERATION MODE	CKSEL PIN SETTING	ERROR PIN STATUS	SCKO, BCKO, LRCKO CLOCK SOURCE	DOUT DATA	AUDIO EMPH	FSOUT [1:0]	BFRAME	COUT UOUT
PLL	L	H	PLL (VCO) free-running clock <sup>(1)</sup>	MUTE (Low)	LOW	HL	LOW	LOW
		L	PLL recovered clock	Decoded data	OUT	OUT	OUT	OUT
XTI	H	H	XTI clock	MUTE (Low)	LOW	HL	LOW	LOW
		L	XTI clock	MUTE (Low)	OUT	OUT	OUT	LOW
AUTO	Connected to ERROR pin	H	XTI clock	MUTE (Low)	LOW	HL	LOW	LOW
		L	PLL recovered clock	Decoded data	OUT	OUT	OUT	OUT

(1) The VCO free-running frequency is not a constant frequency, because the VCO oscillation frequency is dependent on supply voltage, temperature, and process variations.

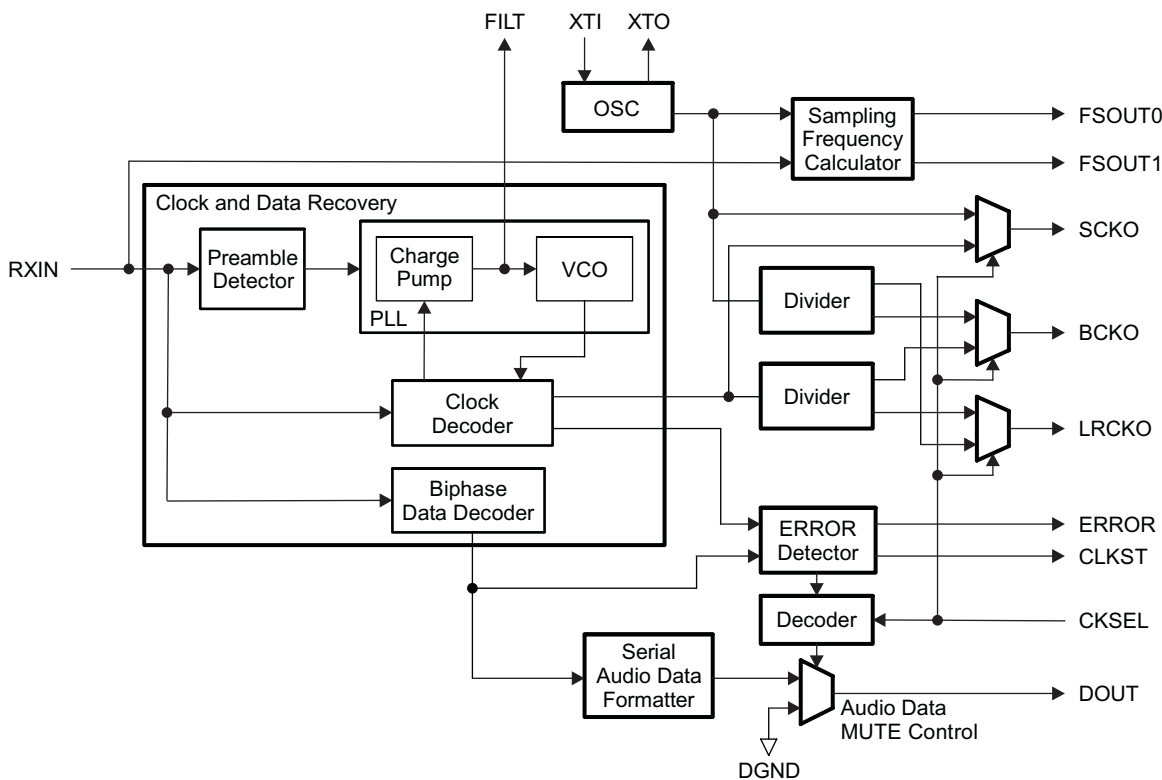

Figure 12. Clock Source, Source Selector and Data Path

8.4.1.2 Clock Transition Signal Out

The DIR9001 provides an output pulse that is synchronized with the PLL's LOCK/UNLOCK status change.

The CLKST pin outputs the PLL status change between LOCK and UNLOCK. The CLKST output pulse depends only on the status change of the PLL.

This clock change/transition signal is output through CLKST.

As this signal indicates a clock transition period due to a PLL status change, it can be used for muting or other appropriate functions in an application.

A clock source selection caused by the CLKSEL pin does not affect the output of CLKST.

# DIR9001

SLES198A – DECEMBER 2006 – REVISED MAY 2015

www.ti.com

CLKST does change due to PLL status change even if CKSEL = H in the XTI source mode.

When DIR9001 is reset in the state where it is locked to the biphasic input signal, the pulse signal of CLKST is not output. That is, the priority of reset is higher than CLKST.

The relation among the lock-in/unlock process, the CLKST and ERROR outputs, the output clocks (SCKO, BCKO, LRCKO), and data (DOUT) is shown in [Figure 13](#).

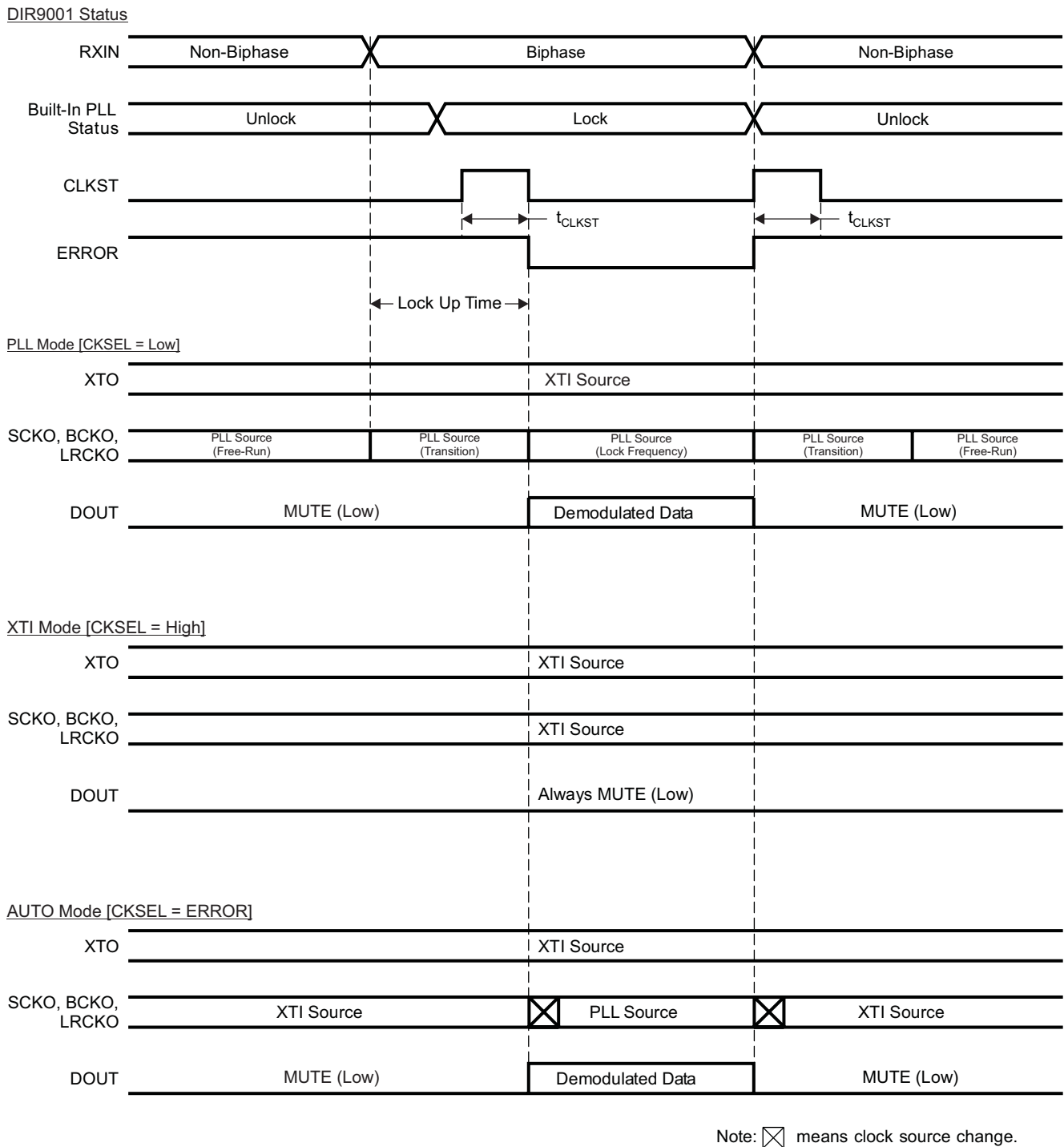

**Figure 13. Lock-In and Unlock Process**

## 8.5 Programming

### 8.5.1 Data Description

#### 8.5.1.1 Decoded Serial Audio Data Output and Interface Format

The DIR9001 supports following 4-data formats for the decoded data.

- 16-bit, MSB-first, right-justified
- 24-bit, MSB-first, right-justified
- 24-bit, MSB-first, left-justified
- 24-bit, MSB-first, I<sup>2</sup>S

Decoded data is MSB first and 2s-complement in all formats.

The decoded data is provided through the DOUT pin.

The format of the decoded data is selected by the FMT[1:0] pins.

The data formats for each FMT[1:0] pin setting are shown in [Table 13](#).

**Table 13. Serial Audio Data Output Format Set by FMT[1:0]**

FMT[1:0] SETTINGS		DOUT SERIAL AUDIO DATA OUTPUT FORMAT
FMT1	FMT0	
L	L	16-bit, MSB-first, right-justified
L	H	24-bit, MSB-first, right-justified
H	L	24-bit MSB-first, left-justified
H	H	24-bit, MSB-first, I <sup>2</sup> S

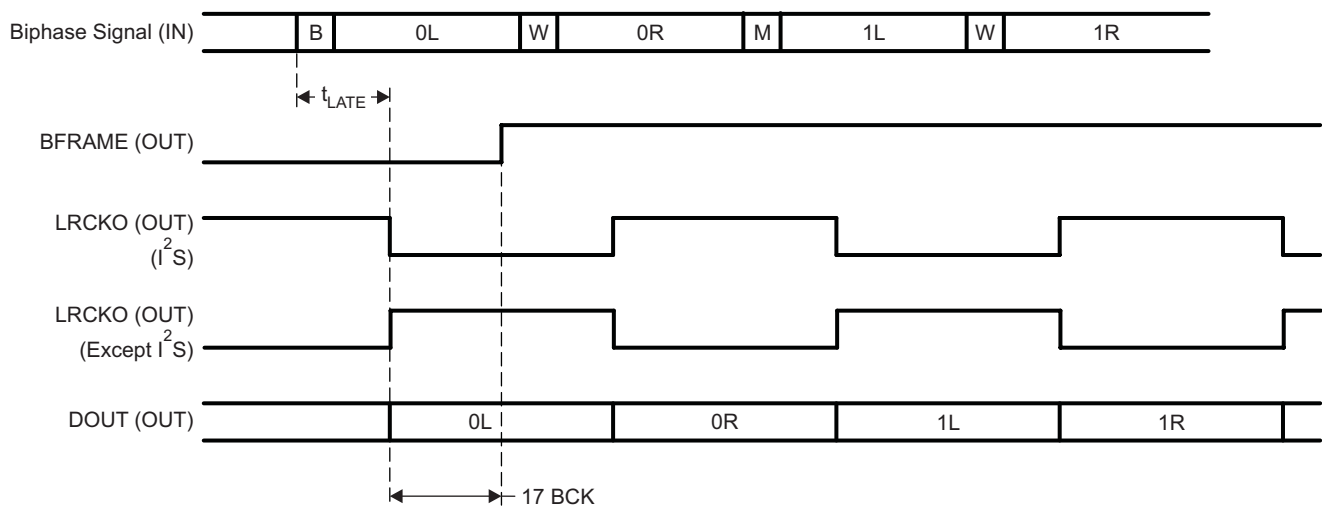

**Figure 14. Latency Time Between Biphase Input and LRCKO/DOUT**

The relationships among BCKO, LRCKO, and DOUT for each format are shown in [Figure 15](#).

Right Justified (MSB First, 24-bit, 16-bit)

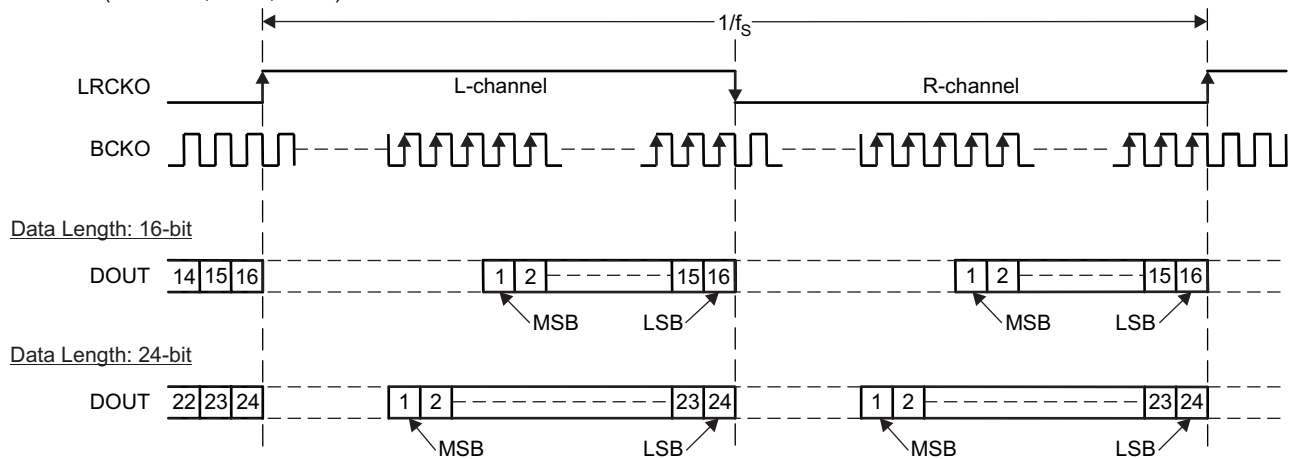

Left Justified (MSB First)

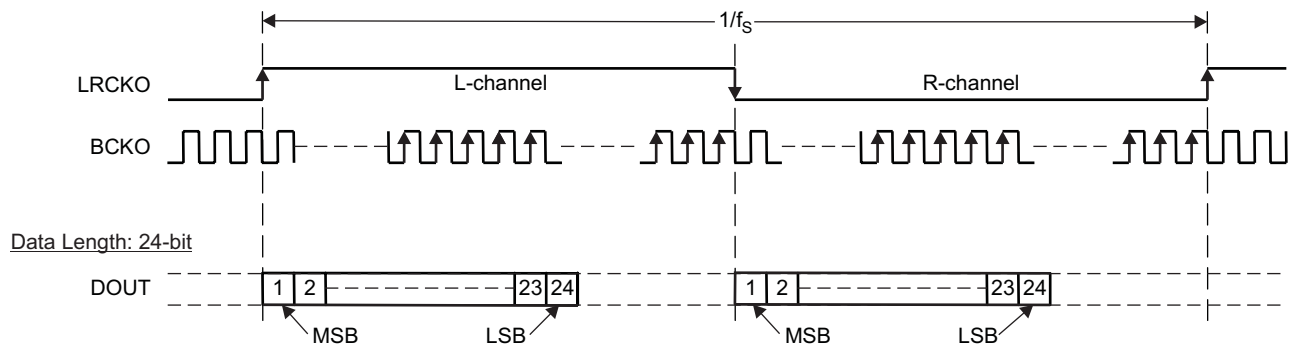

I<sup>2</sup>S Format (MSB First)

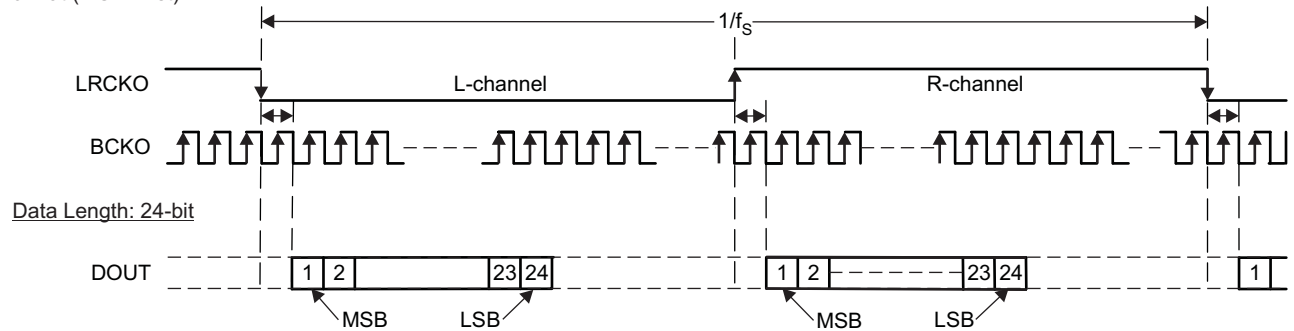
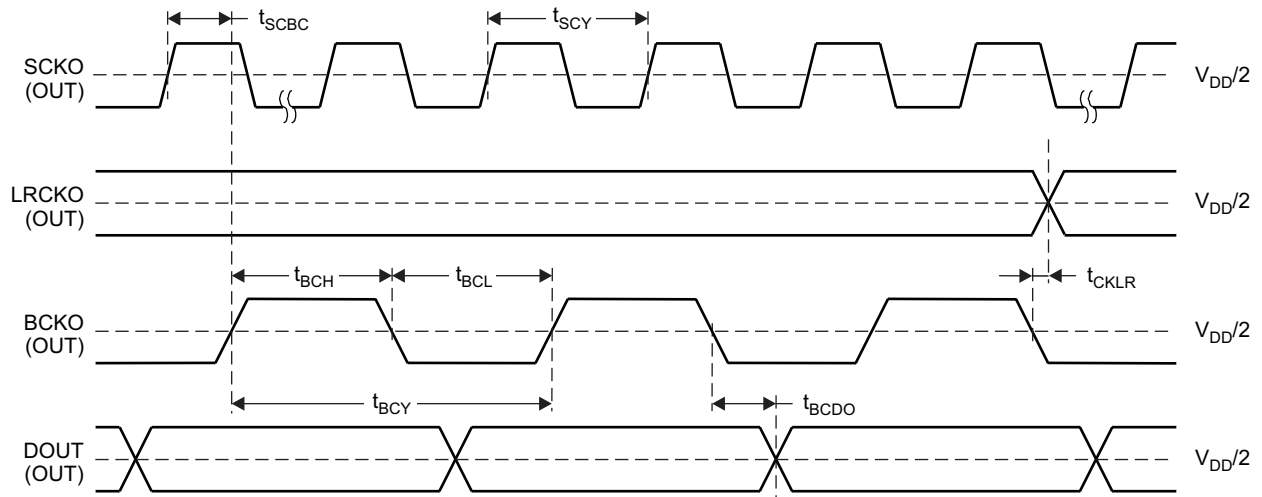

Figure 15. Decoded Serial Audio Data Output Formats



**Figure 16. Decoded Audio Data Output Timing**

## 9 Application and Information

---

### NOTE

Information in the following applications sections is not part of the TI component specification, and TI does not warrant its accuracy or completeness. TI's customers are responsible for determining suitability of components for their purposes. Customers should validate and test their design implementation to confirm system functionality.

---

### 9.1 Application Information

The DIR9001 is an audio receiver capable of accepting S/PDIF, EIAJ CP-1201, IEC60958, and AES/EBU up to a 108-kHz sampling rate. When receiving a biphase differential signal, a clock can be recovered to be used as a master clock or use an external crystal. 16-bit and 24-bit PCM serial audio data can be output in master mode. All settings are controlled in hardware by setting pins high or low, this can be done with pull up/down resistors or with GPIO from a microcontroller. User and channel data from the S/PDIF or AES/EBU standard is processed and output at the UOUT and COUT pins. BFRAME is a synching signal meant to indicate the start of a frame of information. A 3.3-V analog and 3.3-V digital supply are required, this could come from the same 3.3-V supply or separate supplies.

## 9.2 Typical Application

Figure 17 illustrates typical circuit connection.

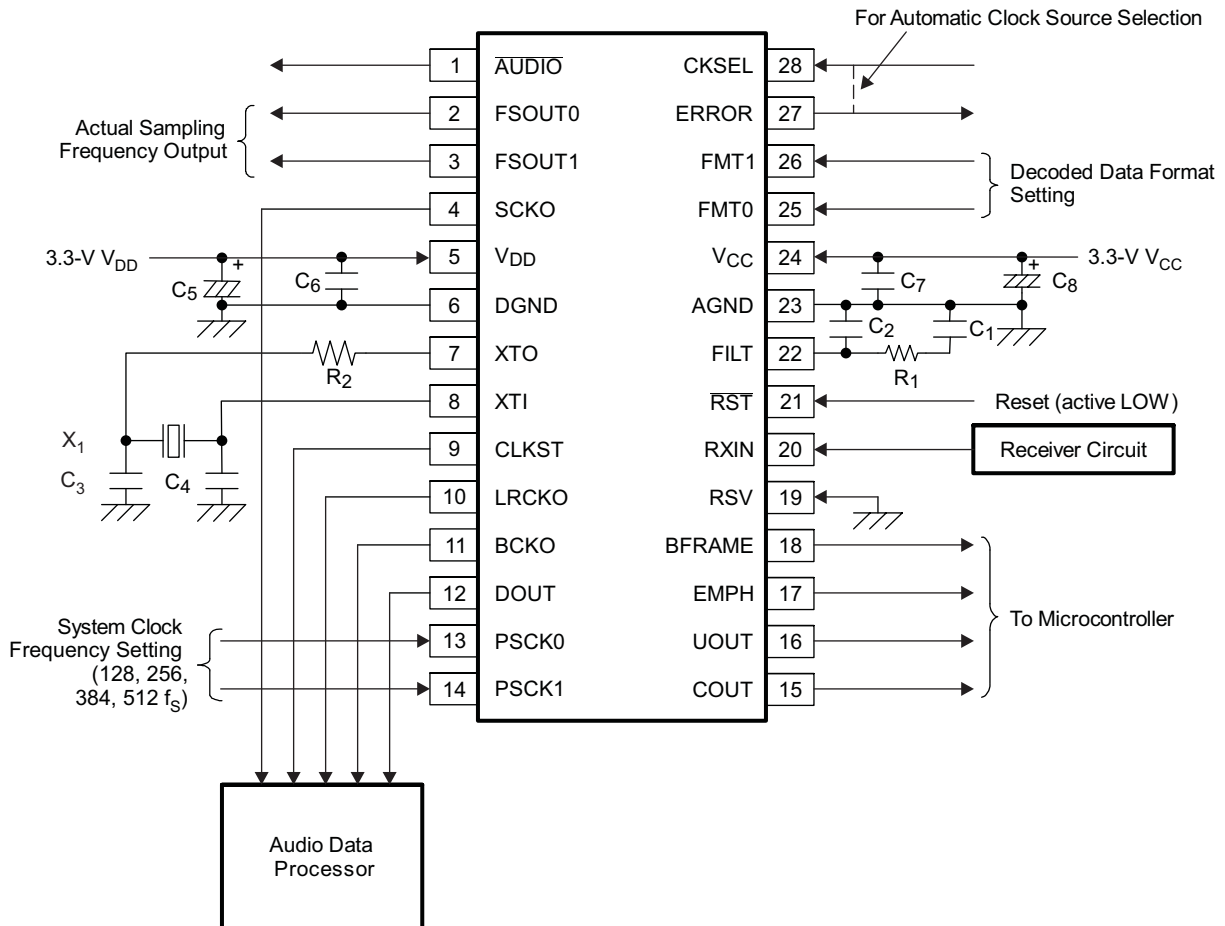

- NOTES: R<sub>1</sub>: Loop filter resistor, 680 Ω  
R<sub>2</sub>: Current-limiting resistor; generally, a 100 Ω–500 Ω resistor is used, but it depends on the crystal resonator.  
C<sub>1</sub>: Loop filter capacitor, 0.068 μF.  
C<sub>2</sub>: Loop filter capacitor, 0.0047 μF.  
C<sub>3</sub>, C<sub>4</sub>: OSC load capacitor; generally, a 10-pF–30-pF capacitor is used, but it depends on the crystal resonator and PCB layout.  
C<sub>5</sub>, C<sub>8</sub>: 10-μF electrolytic capacitor typical, depending on power-supply quality and PCB layout.  
C<sub>6</sub>, C<sub>7</sub>: 0.1-μF ceramic capacitor typical, depending on power-supply quality and PCB layout.  
X<sub>1</sub>: Crystal resonator, use a 24.576-MHz fundamental resonator when XT1 clock source is needed.

Figure 17. Typical Circuit Connection Diagram

### 9.2.1 Design Requirements

- Control: Hardware
- Audio Input: Biphase differential signal
- Audio Output: PCM serial audio data
- Master Clock: 24.576-MHz crystal

## Typical Application (continued)

### 9.2.2 Detailed Design Procedure

- Hardware control with GPIO of microcontroller
- Select crystal capacitors by reading the crystal data sheet
- Select if system will be run off the recovered clock or the external crystal by setting CKSEL high for the external crystal and low for the recovered clock
- Decide sampling rate and audio related settings
- Configure microcontroller to receive PCM data along with User and Channel data from S/PDIF or AES/EBU data stream

### 9.2.3 Application Curve

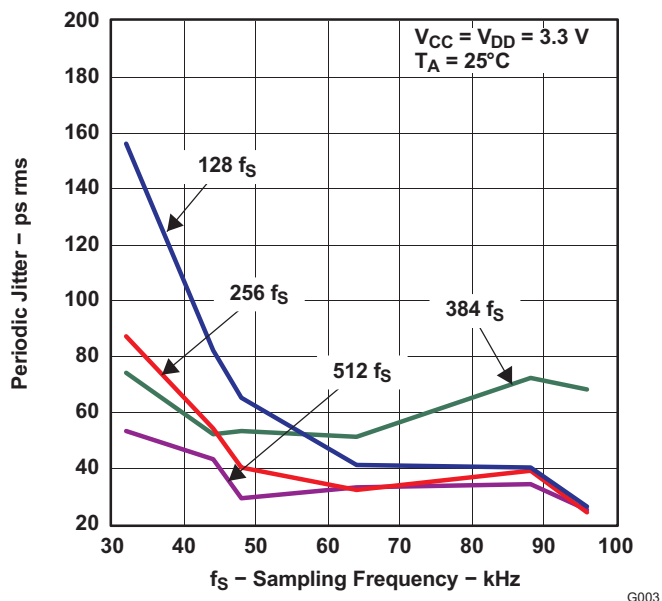

Figure 18. SCKO Jitter vs Locked Sampling Frequency

## 10 Power Supply Recommendations

The DIR9001 requires that 3.3 V be supplied to the digital VDD pin and analog VCC pin. For better separation of analog and digital components two supplies can be used but is not required. Decoupling capacitors for the power supplies should be placed close to the device terminals. For both VDD and VCC, a 10- $\mu$ F and 0.1- $\mu$ F capacitor should be used.

## 11 Layout

### 11.1 Layout Guidelines

- Use a ground plane with multiple vias for each terminal to create a low-impedance connection to GND for minimum ground noise.
- A single common GND plane between AGND and DGND is recommended to avoid a potential voltage difference between them. To avoid signal interference between digital and analog signals, take care to separate analog and digital signals and return paths.
- Use supply decoupling capacitors as shown in [Figure 17](#) and described in [Power Supply Recommendations](#).
- Series resistors can be used on MCLK, LRCK, and BCK to reduce or eliminate reflections and noise. These are to be tuned as each PCB is different but the resistors are usually below 50 Ohms.

## 11.2 Layout Example

It is recommended to place a top layer ground pour for shielding around DIR9001 and connect to lower main PCB ground plane by multiple vias

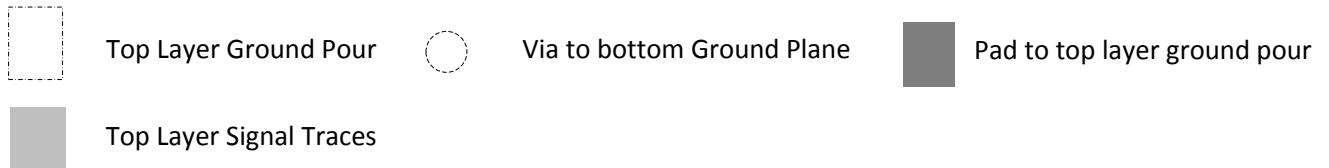
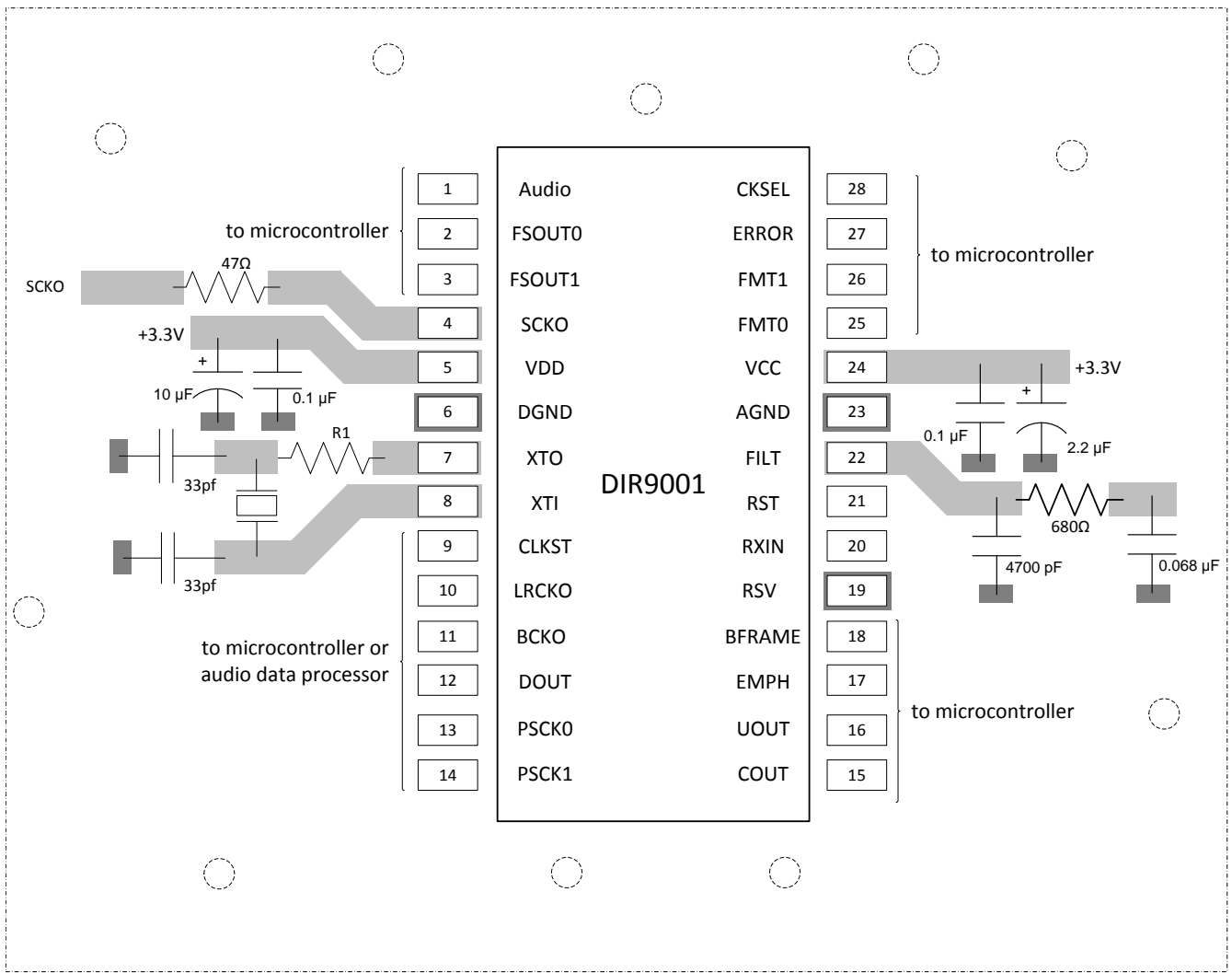

Figure 19. Layout Example

## 12 Device and Document Support

### 12.1 Community Resources

The following links connect to TI community resources. Linked contents are provided "AS IS" by the respective contributors. They do not constitute TI specifications and do not necessarily reflect TI's views; see TI's [Terms of Use](#).

**TI E2E™ Online Community** *TI's Engineer-to-Engineer (E2E) Community*. Created to foster collaboration among engineers. At [e2e.ti.com](http://e2e.ti.com), you can ask questions, share knowledge, explore ideas and help solve problems with fellow engineers.

**Design Support** *TI's Design Support* Quickly find helpful E2E forums along with design support tools and contact information for technical support.

### 12.2 Trademarks

SpAct, E2E are trademarks of Texas Instruments.  
All other trademarks are the property of their respective owners.

### 12.3 Electrostatic Discharge Caution



This integrated circuit can be damaged by ESD. Texas Instruments recommends that all integrated circuits be handled with appropriate precautions. Failure to observe proper handling and installation procedures can cause damage.

ESD damage can range from subtle performance degradation to complete device failure. Precision integrated circuits may be more susceptible to damage because very small parametric changes could cause the device not to meet its published specifications.

### 12.4 Glossary

[SLYZ022](#) — *TI Glossary*.

This glossary lists and explains terms, acronyms, and definitions.

## 13 Mechanical, Packaging, and Orderable Information

The following pages include mechanical, packaging, and orderable information. This information is the most current data available for the designated devices. This data is subject to change without notice and revision of this document. For browser-based versions of this data sheet, refer to the left-hand navigation.

**PACKAGING INFORMATION**

Orderable Device	Status (1)	Package Type	Package Drawing	Pins	Package Qty	Eco Plan (2)	Lead/Ball Finish (6)	MSL Peak Temp (3)	Op Temp (°C)	Device Marking (4/5)	Samples
DIR9001PW	ACTIVE	TSSOP	PW	28	50	Green (RoHS & no Sb/Br)	CU NIPDAU	Level-1-260C-UNLIM	-40 to 85	DIR9001	<a href="#">Samples</a>
DIR9001PWR	ACTIVE	TSSOP	PW	28	2000	Green (RoHS & no Sb/Br)	CU NIPDAU	Level-1-260C-UNLIM	-40 to 85	DIR9001	<a href="#">Samples</a>

(1) The marketing status values are defined as follows:

**ACTIVE:** Product device recommended for new designs.

**LIFEBUY:** TI has announced that the device will be discontinued, and a lifetime-buy period is in effect.

**NRND:** Not recommended for new designs. Device is in production to support existing customers, but TI does not recommend using this part in a new design.

**PREVIEW:** Device has been announced but is not in production. Samples may or may not be available.

**OBsolete:** TI has discontinued the production of the device.

(2) **RoHS:** TI defines "RoHS" to mean semiconductor products that are compliant with the current EU RoHS requirements for all 10 RoHS substances, including the requirement that RoHS substance do not exceed 0.1% by weight in homogeneous materials. Where designed to be soldered at high temperatures, "RoHS" products are suitable for use in specified lead-free processes. TI may reference these types of products as "Pb-Free".

**RoHS Exempt:** TI defines "RoHS Exempt" to mean products that contain lead but are compliant with EU RoHS pursuant to a specific EU RoHS exemption.

**Green:** TI defines "Green" to mean the content of Chlorine (Cl) and Bromine (Br) based flame retardants meet JS709B low halogen requirements of <=1000ppm threshold. Antimony trioxide based flame retardants must also meet the <=1000ppm threshold requirement.

(3) MSL, Peak Temp. - The Moisture Sensitivity Level rating according to the JEDEC industry standard classifications, and peak solder temperature.

(4) There may be additional marking, which relates to the logo, the lot trace code information, or the environmental category on the device.

(5) Multiple Device Markings will be inside parentheses. Only one Device Marking contained in parentheses and separated by a "~" will appear on a device. If a line is indented then it is a continuation of the previous line and the two combined represent the entire Device Marking for that device.

(6) Lead/Ball Finish - Orderable Devices may have multiple material finish options. Finish options are separated by a vertical ruled line. Lead/Ball Finish values may wrap to two lines if the finish value exceeds the maximum column width.

**Important Information and Disclaimer:**The information provided on this page represents TI's knowledge and belief as of the date that it is provided. TI bases its knowledge and belief on information provided by third parties, and makes no representation or warranty as to the accuracy of such information. Efforts are underway to better integrate information from third parties. TI has taken and continues to take reasonable steps to provide representative and accurate information but may not have conducted destructive testing or chemical analysis on incoming materials and chemicals. TI and TI suppliers consider certain information to be proprietary, and thus CAS numbers and other limited information may not be available for release.

In no event shall TI's liability arising out of such information exceed the total purchase price of the TI part(s) at issue in this document sold by TI to Customer on an annual basis.

**OTHER QUALIFIED VERSIONS OF DIR9001 :**

- Automotive: [DIR9001-Q1](#)

## NOTE: Qualified Version Definitions:

- Automotive - Q100 devices qualified for high-reliability automotive applications targeting zero defects

## TAPE AND REEL INFORMATION



### QUADRANT ASSIGNMENTS FOR PIN 1 ORIENTATION IN TAPE



\*All dimensions are nominal

Device	Package Type	Package Drawing	Pins	SPQ	Reel Diameter (mm)	Reel Width W1 (mm)	A0 (mm)	B0 (mm)	K0 (mm)	P1 (mm)	W (mm)	Pin1 Quadrant
DIR9001PWR	TSSOP	PW	28	2000	330.0	16.4	6.9	10.2	1.8	12.0	16.0	Q1

TAPE AND REEL BOX DIMENSIONS

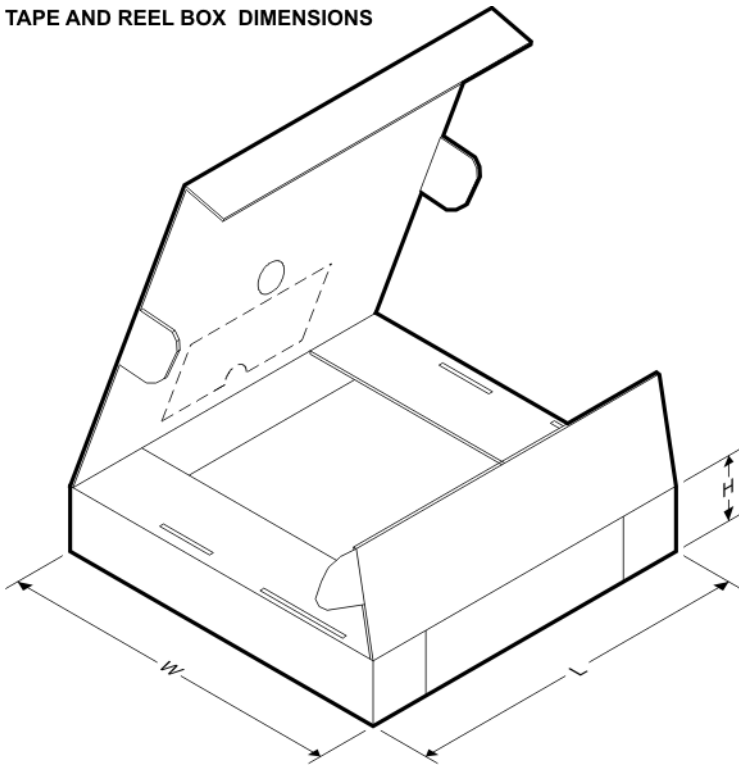

\*All dimensions are nominal

Device	Package Type	Package Drawing	Pins	SPQ	Length (mm)	Width (mm)	Height (mm)
DIR9001PWR	TSSOP	PW	28	2000	350.0	350.0	43.0

# MECHANICAL DATA

PW (R-PDSO-G28)

PLASTIC SMALL OUTLINE

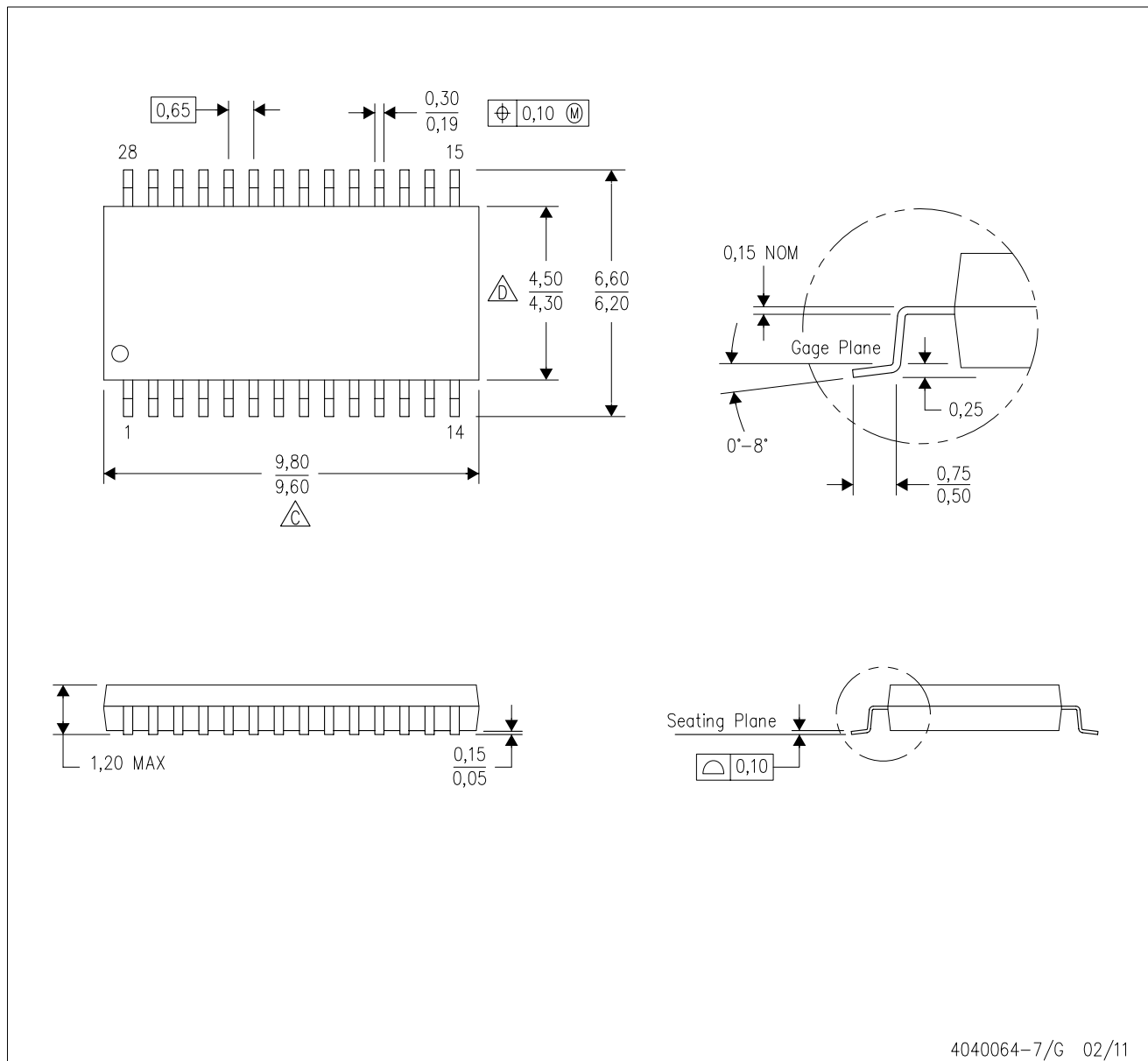

4040064-7/G 02/11

- NOTES:
- A. All linear dimensions are in millimeters. Dimensioning and tolerancing per ASME Y14.5M-1994.
  - B. This drawing is subject to change without notice.
  - C. Body length does not include mold flash, protrusions, or gate burrs. Mold flash, protrusions, or gate burrs shall not exceed 0,15 each side.
  - D. Body width does not include interlead flash. Interlead flash shall not exceed 0,25 each side.
  - E. Falls within JEDEC MO-153

PW (R-PDSO-G28)

PLASTIC SMALL OUTLINE

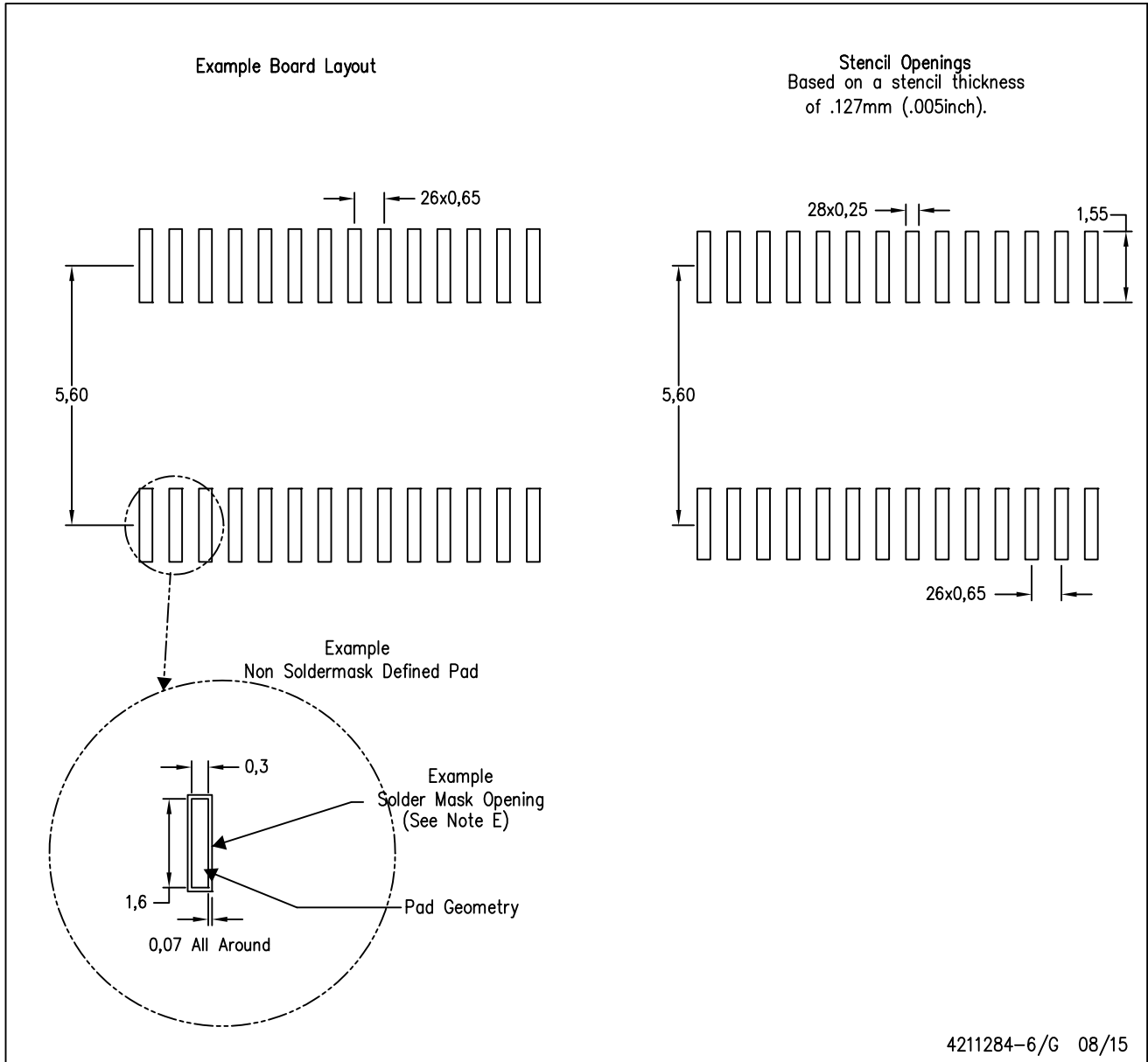

- NOTES:
- A. All linear dimensions are in millimeters.
  - B. This drawing is subject to change without notice.
  - C. Publication IPC-7351 is recommended for alternate design.
  - D. Laser cutting apertures with trapezoidal walls and also rounding corners will offer better paste release. Customers should contact their board assembly site for stencil design recommendations. Refer to IPC-7525 for other stencil recommendations.
  - E. Customers should contact their board fabrication site for solder mask tolerances between and around signal pads.

## IMPORTANT NOTICE AND DISCLAIMER

TI PROVIDES TECHNICAL AND RELIABILITY DATA (INCLUDING DATASHEETS), DESIGN RESOURCES (INCLUDING REFERENCE DESIGNS), APPLICATION OR OTHER DESIGN ADVICE, WEB TOOLS, SAFETY INFORMATION, AND OTHER RESOURCES "AS IS" AND WITH ALL FAULTS, AND DISCLAIMS ALL WARRANTIES, EXPRESS AND IMPLIED, INCLUDING WITHOUT LIMITATION ANY IMPLIED WARRANTIES OF MERCHANTABILITY, FITNESS FOR A PARTICULAR PURPOSE OR NON-INFRINGEMENT OF THIRD PARTY INTELLECTUAL PROPERTY RIGHTS.

These resources are intended for skilled developers designing with TI products. You are solely responsible for (1) selecting the appropriate TI products for your application, (2) designing, validating and testing your application, and (3) ensuring your application meets applicable standards, and any other safety, security, or other requirements. These resources are subject to change without notice. TI grants you permission to use these resources only for development of an application that uses the TI products described in the resource. Other reproduction and display of these resources is prohibited. No license is granted to any other TI intellectual property right or to any third party intellectual property right. TI disclaims responsibility for, and you will fully indemnify TI and its representatives against, any claims, damages, costs, losses, and liabilities arising out of your use of these resources.

TI's products are provided subject to TI's Terms of Sale ([www.ti.com/legal/termsofsale.html](http://www.ti.com/legal/termsofsale.html)) or other applicable terms available either on [ti.com](http://ti.com) or provided in conjunction with such TI products. TI's provision of these resources does not expand or otherwise alter TI's applicable warranties or warranty disclaimers for TI products.

Mailing Address: Texas Instruments, Post Office Box 655303, Dallas, Texas 75265  
Copyright © 2019, Texas Instruments Incorporated

## Looking for pricing, stock, or lifecycle information?

Click below to explore more details on WIN SOURCE:

 [View DIR9001PWR](#) on WIN SOURCE

 [Texas Instruments](#) Information

## Optimize Your Supply Chain with WIN SOURCE Solutions

-  Global Sourcing Solution
-  Obsolete Management
-  Cost Control Management
-  Shortage Management
-  Alternative Solution
-  Excess Inventory Management