



**THE DATASHEET OF
USB5926-I/KD**



USB58XX/59XX Families

SuperSpeed USB 3.1 Gen1 SmartHub Controllers for USB Type-C™ Applications

Summary

New technologies like the USB Type-C connector and power delivery are changing the USB landscape. Designed to simplify the latest USB hub designs, the USB58XX and USB59XX families of 7-port, monolithic USB 3.1 Gen1 hubs incorporate Microchip's unique SmartHub technology. This technology, available in previous generations of Microchip USB hubs, enables I/O bridging and FlexConnect port swapping and switching to deliver expanded functionality. By eliminating the need for additional bridging ICs and high-speed switches, SmartHub technology significantly reduces BOM cost while providing a more robust data interface solution.

These 7-port hubs eliminate the need to tier hubs to provide end users with more than four USB downstream ports, simplifying your PCB design and reducing your costs. The USB58XX and USB59XX are available in different SKUs, depending on the number of upstream and downstream USB Type-C connections your design requires. If your hub application requires power delivery, the built-in Billboard support gives you the option to offload this function from the power delivery controller onto the hub.

Port configurations can be done at boot up through pin strapping or OTP, or at run time via the USB host, removing the need for an EEPROM or other external non-volatile device. Microchip's PortSplitting technology enables each port to be used as a USB 2.0 and USB 3.1 Gen1-only interface for internal connections of bridging devices like USB-to-Ethernet or USB-based Wi-Fi® modules.

For traditional USB Type-A ports, each downstream port can be set to support traditional battery charging (Apple® legacy, BC1.2, China charging, etc.) or shut off completely to save power.

Technical support and design guidance for USB58XX and USB59XX designs is available through our USBCheck™ Design Review, an engineering service that reviews customer schematics and layout designs.

Typical Applications

- Standalone USB hubs
- Laptop docks
- PC motherboards
- PC monitor docks
- Multi-function USB 3.1 Gen1 peripherals

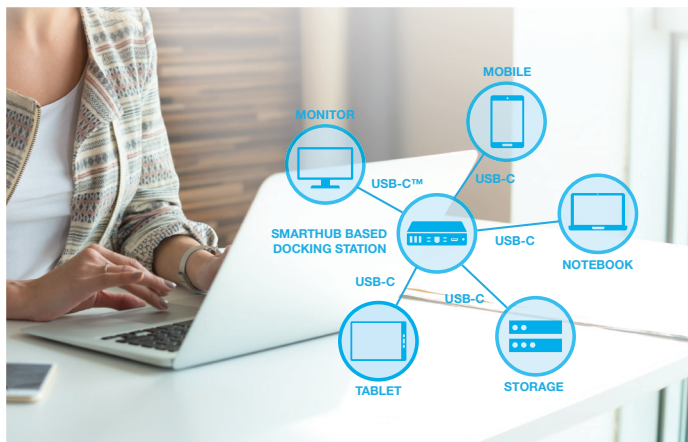

Highlights

- USB Hub with seven USB 3.1 Gen1/USB 2.0 downstream ports
- Integrated Hub Feature Controller (HFC) enabling I/O bridging and FlexConnect
- I/O bridging: host communication to external peripherals
 - Integrated USB to I²C/SPI/GPIO endpoint support
- FlexConnect: host port swapping and switching to a separate downstream device
 - Reversible upstream and downstream Port 1 roles on command
- Integrated 2:1 MUXes for direct support of the new USB Type-C ports
- Integrated Billboard class device for power delivery notification support
- PortSplitting: USB downstream port can be split for custom applications using embedded USB 3.0 devices in parallel with USB 2.0 devices.
- Battery charging: USB-IF rev 1.2 support on downstream ports (DCP, CDP, SDP) including legacy Apple iOS, BlackBerry®, China Charging and many others
- Port bootstraps: predefined configuration of port settings (battery charging, non-removable, disable)
- ProTouch2 configuration utility
 - Ability to program hub through either USB host, OTP or external SPI ROM
 - Includes manufacturing line programming and field update capabilities
- Compatible with Microsoft Windows® 10, 8, 7, XP, Apple OS X® 10.4+, and Linux® hub drivers
- Available in 100-pin (12 × 12 mm) VQFN RoHS-compliant package
- Industrial grade temperature support (-40°C to +85°C)
- Automotive quality and PPAP support



MICROCHIP

Features and Benefits

Features	Benefits
Integrates Microchip's proven USB 2.0/USB 3.1 Gen1 hub technology	Leverages Microchip's 15-year history of interoperability
USB-to-I ² C/SPI/GPIO communication bridging	Simplifies design, BOM reduction
Port swapping and switching	Enables intelligent downstream device or second host system control
Intelligent 2:1 port muxing	Enables direct interface to USB Type-C™ ports
Embedded port splitting	Splits USB 2.0 and USB 3.0 ports for internal use

Block Diagram

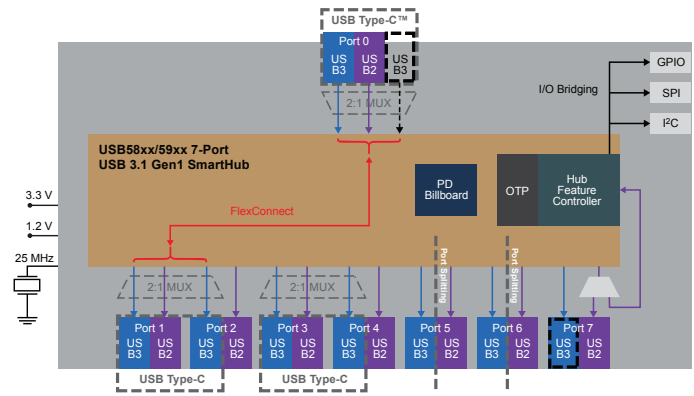

Development Tools

USB5806 USB 3.1 Gen1 6-Port SmartHub Evaluation Board (EVB-USB5806)

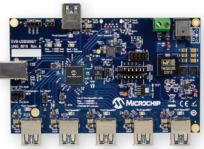

- Legacy B connector upstream
- Six Type-A USB 2.0/USB 3.1 Gen1 downstream ports

USB5807 USB 3.1 Gen1 7-Port SmartHub Evaluation Board (EVB-USB5807)

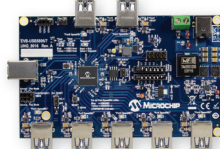

- Legacy B connector upstream
- Seven Type-A USB 2.0/USB 3.1 Gen1 downstream ports
- No HFC support

USB5926 USB 3.1 Gen1 6-Port with USB Type-C SmartHub Evaluation Board (EVB-USB5926)

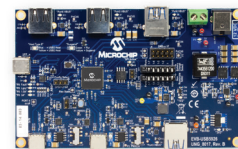

- USB Type-C USB connector upstream
- Two USB Type-C USB2.0/USB 3.1 Gen1 downstream ports
- Two Type-A USB 2.0/USB 3.1 Gen1 and two Type-A USB 2.0 only downstream ports

Which USB5XXX Family Member is Right for Your Design?

Part Number	Total DFPs	Package	Package Size	USB Type-C™ UFP	USB Type-C DFP	I/O Bridging	FlexConnect	Industrial Versions
USB5807	7	100-pin SQFN	12 × 12 mm	–	0	–	–	✓
USB5806	6	100-pin SQFN	12 × 12 mm	–	0	✓	✓	✓
USB5816	6	100-pin SQFN	12 × 12 mm	–	1	✓	✓	✓
USB5826	6	100-pin SQFN	12 × 12 mm	–	2	✓	✓	✓
USB5906	6	100-pin SQFN	12 × 12 mm	✓	0	✓	✓	✓
USB5916	6	100-pin SQFN	12 × 12 mm	✓	1	✓	✓	✓
USB5926	6	100-pin SQFN	12 × 12 mm	✓	2	✓	✓	✓

UFP = Upstream Facing Port
DFP = Downstream Facing Port



MICROCHIP
www.microchip.com/USB

Visit our web site for additional product information and to locate your local sales office.



Microchip Technology Inc. • 2355 W. Chandler Blvd. • Chandler, AZ 85224-6199

Microcontrollers • Digital Signal Controllers • Analog • Memory • Wireless

The Microchip name and logo and the Microchip logo are registered trademarks and USBCheck is a trademark of Microchip Technology Incorporated in the U.S.A. and other countries. All other trademarks mentioned herein are property of their respective companies. USB Type-C and USB-C are trademarks of USB Implementers Forum. © 2016, Microchip Technology Incorporated. All Rights Reserved. Printed in the U.S.A. 10/16
DS00002311A

Looking for pricing, stock, or lifecycle information?

Click below to explore more details on WIN SOURCE:

-  [View USB5926-I/KD on WIN SOURCE](#)
-  [Microchip Technology](#) Information

Optimize Your Supply Chain with WIN SOURCE Solutions

-  Global Sourcing Solution
-  Obsolete Management
-  Cost Control Management
-  Shortage Management
-  Alternative Solution
-  Excess Inventory Management