



**THE DATASHEET OF
KSZ8441HLI-EVAL**



KSZ8441HL Evaluation Board User Guide

Revision 1.0 / July 17, 2013

Table of Contents

| | |
|---|----|
| Introduction..... | 3 |
| 1 Board Features | 3 |
| 2 KSZ8441HL Evaluation Board Kit | 3 |
| 3 Hardware Description..... | 4 |
| 3.1 Device Configuration | 5 |
| 3.1.1 Strap-in Configuration..... | 5 |
| 3.1.2 EEPROM Configuration..... | 5 |
| 3.2 Power Supplies..... | 5 |
| 3.3 Parallel Host Interface | 6 |
| 3.4 GPIO pins..... | 8 |
| 3.5 10/100 Ethernet PHY Ports | 9 |
| 3.6 100BASE-FX Fiber Port Option | 9 |
| 3.7 LED Indicators..... | 9 |
| 3.8 List of Jumpers and Connectors | 10 |
| 3.9 Board Layout..... | 11 |
| 4 Using the KSZ8441HL Evaluation Board..... | 11 |
| 5 Reference Documents | 12 |
| 6 Revision History | 12 |

List of Figures

| | |
|---|----|
| Figure 1 KSZ8441HL Evaluation Board | 4 |
| Figure 2 Power Supply Section and Related Jumper Locations..... | 6 |
| Figure 3 GPIO Connectors and Strap-in Jumper Locations | 8 |
| Figure 4 Topside Layout of the Board..... | 11 |

List of Tables

| | |
|--|----|
| Table 1 Strap-In Configuration Jumpers | 5 |
| Table 2 Power Supply Related Jumpers | 6 |
| Table 3 Signal Descriptions on the Parallel (Host-Port) Connector J16..... | 7 |
| Table 4 GPIO Pin Selection for KSZ8441HL..... | 8 |
| Table 5 LED Functions | 9 |
| Table 6 List of Jumpers and Connectors..... | 10 |

Introduction

The KSZ8441HL Evaluation Board provides a platform in which to test or explore the functionality of the KSZ8441HL IEEE 1588 Precision Time Protocol (PTP) enabled switch products.

The KSZ8441HL and KSZ8441FHL devices are 1-port 10BASE-T / 100BASE-TX/FX Ethernet end points with a generic parallel host interface. This is the ideal solution in industrial applications where real time clock synchronization using Ethernet connectivity across a network is desired. The KSZ8441HL is fully compliant with the IEEE 1588 (Version 2) Precision Time Protocol and IEEE 802.3 (10/100BASE-T/TX) standards.

This KSZ8441HL Evaluation Board User Guide provides the information necessary to configure and set up the board to evaluate or test the KSZ8441HL devices in different environments.

1 Board Features

The KSZ8441HL Evaluation Board encompasses the following features.

- Micrel's KSZ8441HL IEEE 1588 Precision Time Protocol 10/100 Ethernet End Point
- Ethernet LAN Interface with RJ-45 jack and isolation magnetics
- Auto MDI/MDI-X for automatic detection and correction for straight-through and crossover cables
- Generic 8/16 bit parallel host processor interface
- Provisioning for 100BASE-FX fiber interface (optional)
- Provisioning for line side and chip side over-voltage protection (optional)
- On-board 3.3V and 1.8V/2.5V regulators
- Configurable for VDDIO of 3.3V, 2.5V, or 1.8V operation
- Serial port interface for EEPROM
- LED indicators for link status and activity of the RJ-45 port
- On-board 25 MHz crystal
- Jumpers for power up configuration of the device
- Jumpers for GPIO pins, I/O voltage selection and serial-port connections
- 5V DC voltage required for operation
- Reset switch
- Various test points

2 KSZ8441HL Evaluation Board Kit

The KSZ8441HL Evaluation Board kit includes the following:

- KSZ8441HL Evaluation Board
- KSZ8441HL Evaluation Board User's Guide (This document, available in the eval kit, on the Micrel website)
- KSZ8441HL Evaluation Board Schematic (Available in the eval kit, on the Micrel website)

3 Hardware Description

The KSZ8441HL Evaluation board uses the same PCB as the KSZ8462HL Evaluation board. The KSZ8441 has one less Ethernet port, so there are components and connectors on the board which are unused with the KSZ8441.

It is a small form-factor board (5.2" x 4.75") that can be configured by a host processor connected through the 16-bit generic parallel host interface. In addition to passing full-rate Ethernet traffic, the external host processor can read and write the entire register set within the KSZ8441HL device through this interface.

The board supports different types of host processors. Therefore a strap-in configuration mode is provided to set the parallel interface according to the type of processor used. Strap-in mode configuration occurs at power on time where the voltage level on certain pins is automatically sampled and used to configure various features in the device. This is accomplished with the on board jumper options.

Available configuration options are explained in detail in the following sections. Figure 1 is a picture of the KSZ8441HL Evaluation board.

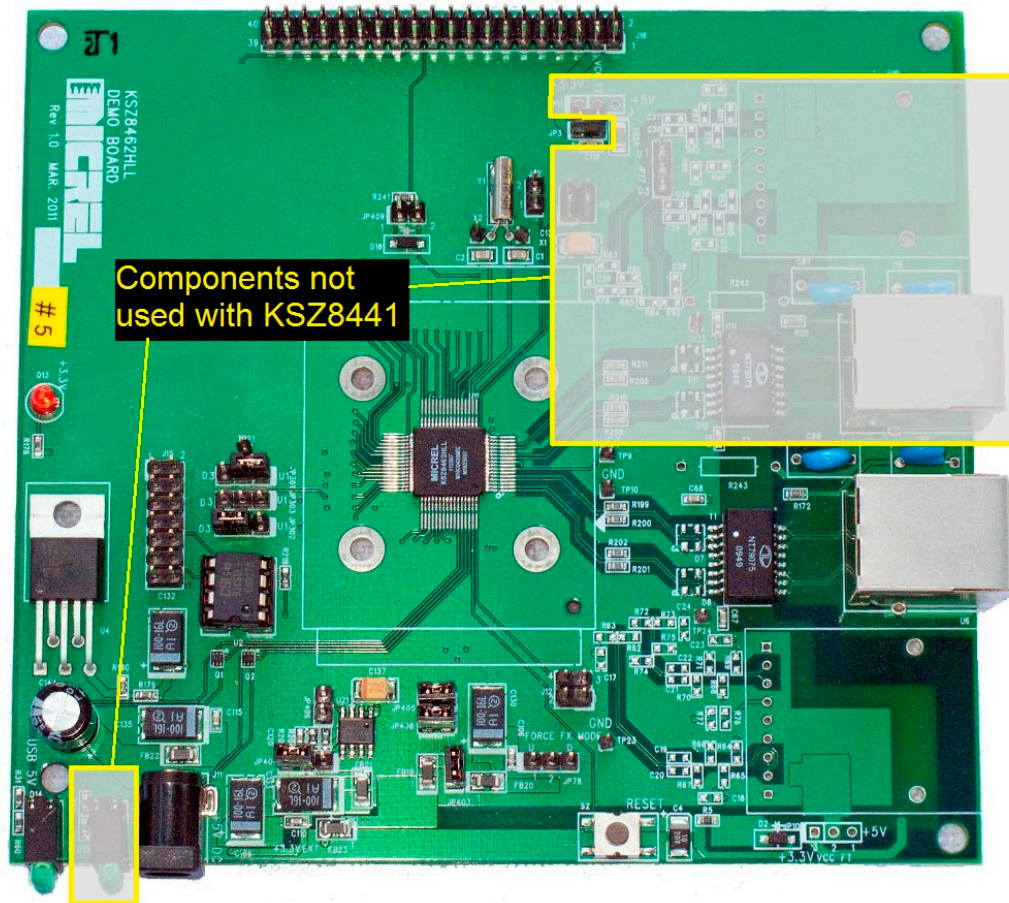

Figure 1 KSZ8441HL Evaluation Board

3.1 Device Configuration

3.1.1 Strap-in Configuration

Strap-in configuration is used for setting up the parallel host interface and to indicate the presence of an EEPROM. This is accomplished by setting available configuration jumpers which are used at device power-up. Simply set the board's configuration jumpers to the desired settings and apply power to the board. The configuration can be changed while power is applied to the board by changing the jumper settings and pressing the convenient manual reset button for the new settings to take effect. Note that even if no external strap-in jumpers are set, internal pull-up and pull-down resistors will set the KSZ8441HL to the default configuration.

The following table covers each jumper used for the strap-in option and describes its function.

| JUMPER | FUNCTION | SETTING | DEFAULT |
|--------|---------------------------------|--|--------------------|
| JP301 | Parallel Bus Width select | Pins 1-2 closed: 16-bit Pins 2-3 closed: 8-bit | 16-bit |
| JP302 | Parallel Bus Endian-mode select | Pins 1-2 closed: Little Endian Pins 2-3 closed: Big Endian | Little Endian |
| JP303 | EEPROM select | Pins 1-2 closed: EEPROM present Pins 2-3 closed: EEPROM not present | EEPROM not present |

Table 1 Strap-In Configuration Jumpers

3.1.2 EEPROM Configuration

The KSZ8441HL Evaluation Board has a serial EEPROM to enable loading the MAC address into the device at power-up time with a pre-programmed value. The strap-in option should be set to enable the EEPROM presence, as indicated on the above table. If enabled, the first seven words of the Serial EEPROM will be read. Registers 0x010 – 0x015 will be loaded with words 0x01 – 0x03 from the EEPROM.

In addition, the remainder of EEPROM space (0x07 – 0x3F) can be written or read and used as needed by the host processor.

Supported EEPROM: 93C46

3.2 Power Supplies

The board requires a single 5V DC supply, which can be provided through a barrel power-supply jack (J11) or through the parallel host port. The current requirement is 200mA. When configured for fiber operation, expect the fiber modules to draw approximately 250mA of additional current.

The pin diameter of jack J11 is 2.5mm on early boards, and is 2.1mm on newer boards. 2.5mm plugs are recommended because they are generally compatible with both jack sizes. A 2.1mm plug, however, cannot be used with the 2.5mm jack.

JP3 must be in place if the board is powered through the parallel port. There is a 3.3V regulator on the board supplying power for the KSZ8441 and other components. A separate on-board voltage regulator is

provided for the optional 2.5V and 1.8V supplies for KSZ8441's I/O interface (VDD_IO). JP404 and JP406 are used for VDD_IO selection. JP403 and JP405 must be in place and other options properly selected before powering up the board.

| JUMPER | FUNCTION | SETTING | | |
|--------|--|--|-----------------|-----------------|
| JP3 | Enable +5V supply from host-port connector J16 | Closed: enabled Open: disabled, use external power supply through J11 | | |
| JP403 | +3.3V supply for KSZ8441 analog circuits | Must be closed | | |
| JP405 | +1.2V supply for KSZ8441 analog circuits | Must be closed | | |
| JP408 | +1.2V supply for KSZ8441 digital circuits | Must be closed | | |
| | VDD_IO selection | 3.3V | 2.5V | 1.8V |
| JP404 | | Pins 2-3 closed | Pins 1-2 closed | Pins 1-2 closed |
| JP406 | | X | open | Closed |

Table 2 Power Supply Related Jumpers

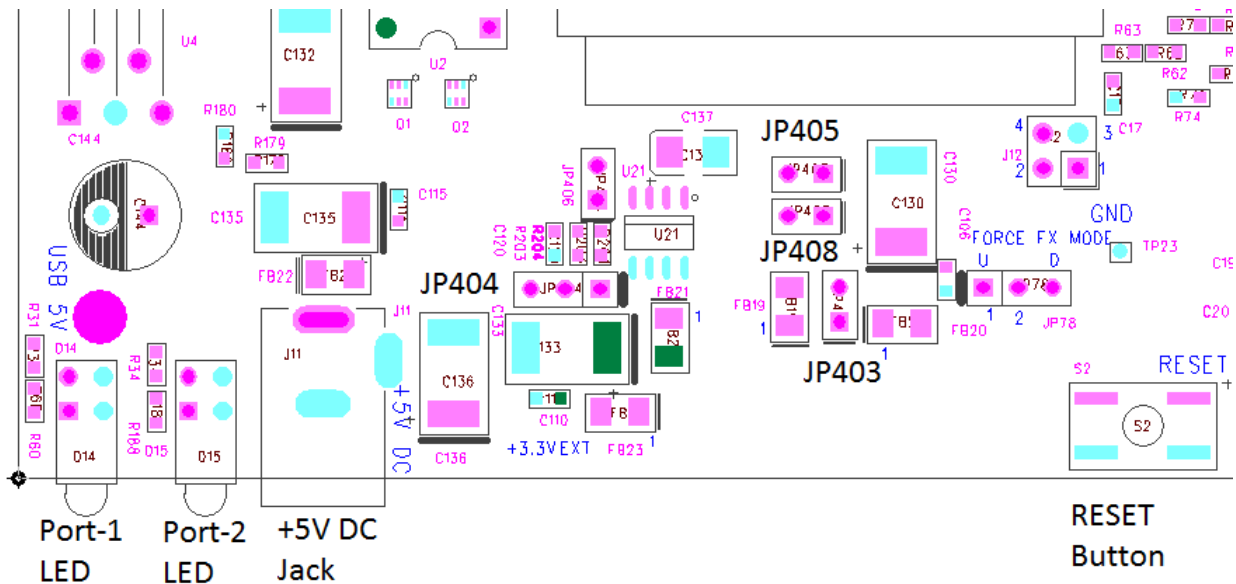

Figure 2 Power Supply Section and Related Jumper Locations

3.3 Parallel Host Interface

The board features a 40-pin connector (J16) for interfacing the Bus Interface Unit (BIU) on the KSZ8441HL to an external host processor. The BIU is a generic parallel host interface providing access to the MAC of Port 3.

The 40-pin connector is a standard dual-row straight pin header. In order to evaluate the IEEE1588 PTP functionality, a host processor board such as the Micrel KSZ9692MII-PTP-EV or KSZ9692PB-PTP-EVAL board has to be connected to the parallel interface. Strap-in configurations determine the mode of host interface operation at power-up.

The voltage level on all interface pins (VDD_IO) can be set to 1.8V, 2.5V or 3.3V of operation, enabling a direct connection to different type of host processors.

| Signal | Pin No. | Type | Function |
|----------------|---|------------------|--|
| SD[15:0] | 5-20 | I/O | Shared Data Bus In 16-bit mode: SD[15:0] -> D[15:0] data access when CMD = "0". SD[10:2] -> A[10:2] address access and SD[15:12] -> BE[3:0] byte enable access when CMD = "1" (SD[1:0] and SD[11] are not used). In 8-bit mode: SD[7:0] -> D[7:0] data access when CMD = "0". SD[7:0] -> A[7:0] 1 st address access and SD[2:0] -> A[10:8] 2 nd address access when CMD = "1" (SD[7:3] are not used during 2 nd address access). |
| CMD | 28 | Input | Command Type This command input determines the SD[15:0] shared data bus access cycle information. 0: Data access 1: Command access for address and byte enable |
| CSN | 23 | Input | Chip Select Enable Chip Enable is an active low signal used to enable the shared data bus access. |
| INTRN | 31 | Output | Interrupt This low active signal asserted low when an interrupt is being requested. |
| RDN | 36 | Input | Asynchronous Read This low active signal is asserted to low during a read cycle. A 4.7K pull-up resistor is recommended on this signal. |
| WRN | 35 | Input | Asynchronous Write This low active signal is asserted low during a write cycle. |
| PME/ EEPROM | 27 | Output/ Input | Power Management Event This output signal indicates that a Wake On LAN event has been detected. The KSZ8441HL is requesting the system to wake up from low power mode. Its assertion polarity is programmable with the default polarity to be active low. EEPROM select Configuration Mode During Power-on/Reset time this pin is an input and the strap-in value is read by KSZ8441HL to determine the presence of an EEPROM. (see description of JP303 in Table 1) |
| RSTN | 24 | Input | Reset This is the Hardware reset pin. It is active Low. This reset input is required to be low for a minimum of 10 ms after supply voltages VDD_IO and 3.3V are stable. |
| +5V | 1, 3 | | Power supply Connection to +5V supply of the Host processor board. |
| GND | 2, 4, 21, 22, 25, 26, 29, 33, 34, 37-40 | | Ground |
| N.C. | 30, 32 | | |

Table 3 Signal Descriptions on the Parallel (Host-Port) Connector J16

3.4 GPIO pins

KSZ8441HL chip has up to 7 General Purpose I/O (GPIO) pins which are available on the evaluation board at connector J15. Three GPIO pins of the KSZ8441HL device are shared with EEPROM signals and are user programmable. By default the EEPROM signals are enabled, therefore initially only 4 GPIO pins are available. If more than 4 GPIO pins are required, the user needs to program IOMUXSEL register (0x0D6) as follows:

| IOMUXSEL register (0x0D6) | Description | Setting |
|---------------------------|--|--|
| Bit 5 | Selection of EESK or GPIO3 for Pin 53 | 1 = This pin is used for EESK (default) 0 = This pin is used for GPIO3 |
| Bit 2 | Selection of EEDIO or GPIO4 for Pin 54 | 1 = This pin is used for EEDIO (default) 0 = This pin is used for GPIO4 |
| Bit 1 | Selection of EECS or GPIO5 for Pin 55 | 1 = This pin is used for EECS (default) 0 = This pin is used for GPIO5 |

Table 4 GPIO Pin Selection for KSZ8441HL

GPIO signals are on the odd numbered pins of connector J15. All even numbered pins are GND connections. The GPIO pins can be used for any general purpose I/O as well as to support IEEE1588 PTP functionality.

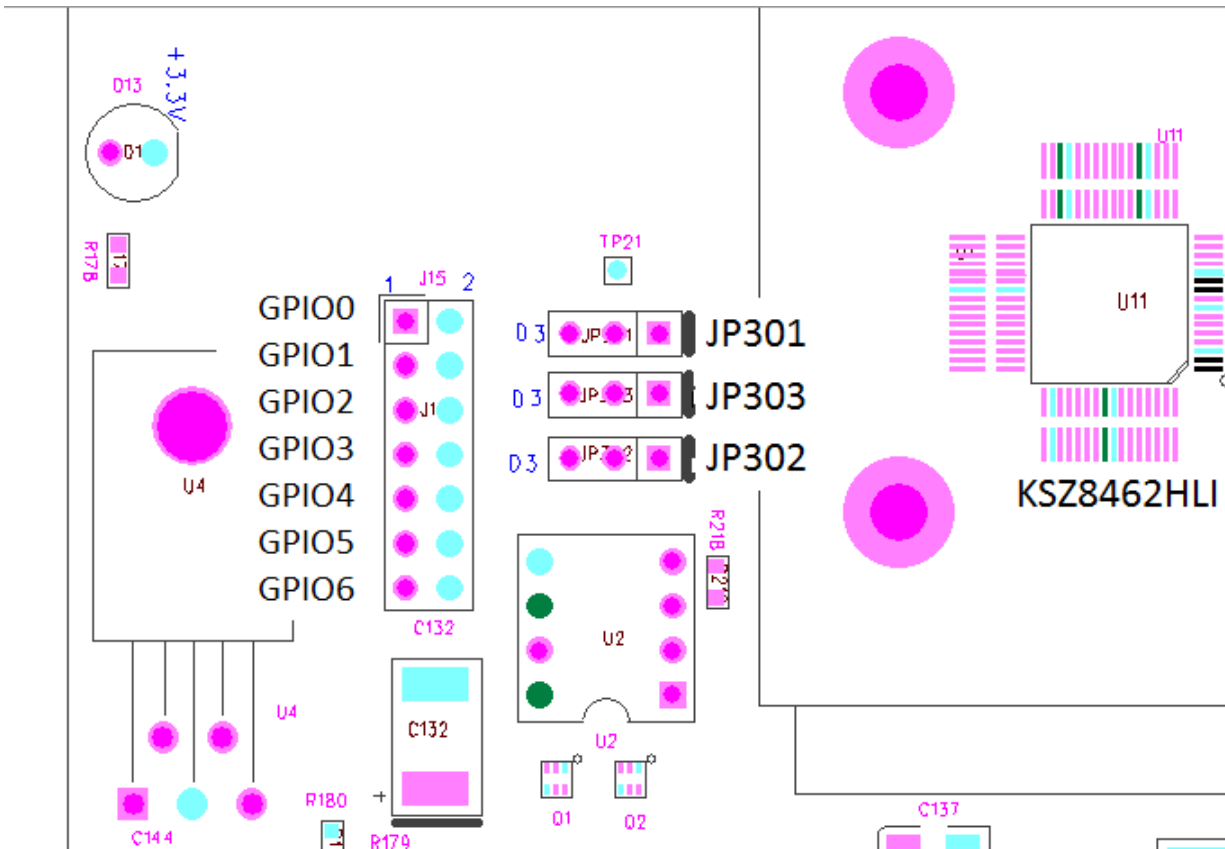

Figure 3 GPIO Connectors and Strap-in Jumper Locations

3.5 10/100 Ethernet PHY Ports

There is one 10/100 Ethernet PHY port on the KSZ8441HL evaluation board. The ports can be connected to an Ethernet traffic generator or analyzer via standard RJ-45 connectors using CAT-5 (or better) UTP cables. Both ports support auto MDI/MDI-X, eliminating the need for cross-over cables.

Transformers are utilized for proper interfacing to an Ethernet network. In addition, optional over-voltage protection devices D5 thru D12 may be installed to protect the KSZ8441 in the event of an over-voltage condition.

For 10/100 Ethernet, the FXSD1 and FXSD2 pins should be pulled low by installing jumpers on pins 3 & 4 of J12 and J13.

3.6 100BASE-FX Fiber Port Option

There are two 100BASE-FX PHY ports on the KSZ8441HL evaluation board, which are not populated with necessary components. The ports can be connected to an Ethernet traffic generator or analyzer via fiber transceiver and fiber cable. In 100BASE-FX operation, both fiber signal detect input FXSD1 and FXSD2 are usually connected to the fiber transceiver SD (signal detect) output pin. This is done by jumpering pins 1 & 2 of J12 (Port 1) and J13 (Port 2). No jumpers are required on JP77 and JP78 except as noted below. Capacitors C5 and C6 are also generally not required.

100BASE-FX is supported by the KSZ8441FHL device. All KSZ8441 devices power up in copper mode. Fiber Mode is selected by clearing the appropriate bits in the GFCR register (0x0D8 – 0x0D9).

The fiber signal detect threshold is set to 1.7V internally. When FXSD is less than the threshold, no fiber signal is detected and a far-end fault (FEF) is generated. When FXSD is over the threshold, the fiber signal is detected. To ensure proper operation, a resistive voltage divider is recommended to adjust the fiber transceiver SD output voltage swing to match the FXSD pin's input voltage threshold.

Alternatively, the user may choose not to implement the FEF feature. In this case, the FXSD input pin may be pulled high via jumpers JP77 and JP78.

3.7 LED Indicators

The KSZ8441HL evaluation board provides two LEDs (PxLED1, PxLED0) for each PHY port. The LED indicators are programmable to four different states. LED mode is selected through bits [9:8] of the SGR7 register (0x00E-0x00F).

The LED mode definitions are specified in Table 7. See Figure 2 for the LEDs' orientation on the KSZ8441HL evaluation board in the power supply section.

| SGCR7 Control Register (0x00E-0x00F) Bits[9:8] | | | |
|--|-----------------|----------------------|-----------------|
| 00 (default) | 01 | 10 | 11 |
| PxLED1 = Speed | PxLED1 = Active | PxLED1 = Duplex | PxLED1 = Duplex |
| PxLED0 = Link/Active | PxLED0 = Link | PxLED0 = Link/Active | PxLED0 = Link |

Table 5 LED Functions

The KSZ8441HL evaluation board also has a power LED (D3) for the 3.3V power supply. When D3 is illuminated, the board's 3.3V power supply is "on".

The activity LED indicators for Port-1 and Port-2 are powered by 3.3V, regardless of the VDD_IO selected for the device.

3.8 List of Jumpers and Connectors

| Jumper | Description | Setting |
|-----------|---|--|
| JP2 | PWRDN Chip Power-down | Place Jumper for full chip power-down |
| JP3 | Enable +5V supply from host-port connector | Closed: enabled Open: disabled |
| JP10, 11 | Power selection for the Fiber module | Leave open when no Fiber Module present |
| JP77, 78 | FXSD1, FXSD2 Fiber signal detect input for Port 1 and Port 2 (not used) | |
| JP301-303 | Strapping options | See Table 1 |
| JP403-408 | Power-supply strapping options | See Table 2 |
| JP409 | Enable bi-directional Reset signal | Closed: enable Reset signal on both directions Open: Local reset signal does not affect the host processor board. |
| J1, J2 | RJ45 connectors for Port-1 and Port-2 | |
| J11 | +5V DC Power Jack | |
| J12, J13 | FXSD pin connections | Pins 1-2 closed: connect to SD signal from fiber module Pins 3-4 closed: ground the FXSD pins, for copper mode |
| J15 | GPIO Header | |
| J16 | Parallel Host-port interface (Port-3) | |

Table 6 List of Jumpers and Connectors

3.9 Board Layout

The layout of the board is shown in Figure 3. The key areas are indicated.

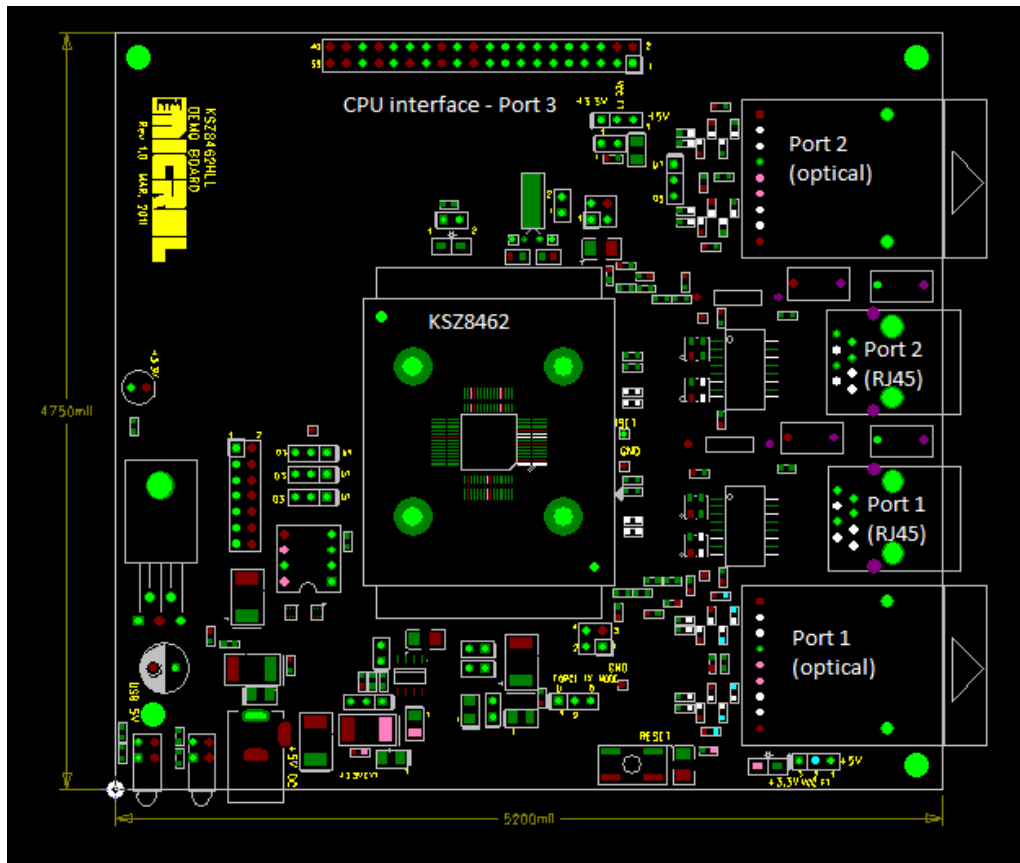

Figure 4 Topside Layout of the Board

The KSZ8441HL Evaluation board, together with the KSZ9692PB SOC board (KSZ9692-MII-PTP-EV), provides a complete evaluation platform for the IEEE1588 PTP functionality. In this setup, Port3 of the KSZ8441 evaluation board is connected to the SOC board through its parallel host interface. For more details on this configuration, refer to the KSZ8441HL Evaluation Kit User Guide.

4 Using the KSZ8441HL Evaluation Board

The Evaluation Board is intended to provide a platform that enables designers to investigate and evaluate the capabilities of the KSZ8441 device. It is not intended to be a complete development system to be used for an entire product design effort.

5 Reference Documents

KSZ8441HL Datasheet (Contact Micrel for latest Datasheet)
KSZ8441HL Evaluation Board Schematic (Contact Micrel for latest Schematic)
KSZ8441HL Evaluation Board Gerber files
IEEE802.3 Specification
KSZ8441HL Evaluation Kit User Guide

6 Revision History

| Revision | Date | Summary of Changes |
|----------|-----------|--------------------|
| 1.0 | 7/17/2013 | - Initial Release |

© Micrel, Inc. 2013
All rights reserved

Micrel is a registered trademark of Micrel and its subsidiaries in the United States and certain other countries. All other trademarks are the property of their respective owners.

The information furnished by Micrel in this datasheet is believed to be accurate and reliable. However, no responsibility is assumed by Micrel for its use. Micrel reserves the right to change circuitry and specifications at any time without notification to the customer. Micrel Products are not designed or authorized for use as components in life support appliances, devices or systems where malfunction of a product can reasonably be expected to result in personal injury. Life support devices or systems are devices or systems that (a) are intended for surgical implant into the body or (b) support or sustain life, and whose failure to perform can be reasonably expected to result in a significant injury to the user. A Purchaser's use or sale of Micrel Products for use in life support appliances, devices or systems is at Purchaser's own risk and Purchaser agrees to fully indemnify Micrel for any damages resulting from such use or sale.

Looking for pricing, stock, or lifecycle information?

Click below to explore more details on WIN SOURCE:

-  [View KSZ8441HLI-EVAL on WIN SOURCE](#)
-  [Microchip Technology](#) Information

Optimize Your Supply Chain with WIN SOURCE Solutions

-  Global Sourcing Solution
-  Obsolete Management
-  Cost Control Management
-  Shortage Management
-  Alternative Solution
-  Excess Inventory Management