



**THE DATASHEET OF
BQ75614EVM-021**



BQ79616-Q1, BQ75614-Q1, and BQ79656-Q1 Evaluation Modules



ABSTRACT

The BQ79616-Q1 and BQ75614-Q1 Evaluation Modules user's guide describes the general features, theory of operation, hardware setup, and use of the BQ79616EVM and BQ75614EVM. Throughout this user's guide, the abbreviations *BMS021*, *EVM*, and the term *evaluation module* are synonymous with the two different variants of BMS021, *BQ79616-Q1 Evaluation Module* and *BQ75614-Q1 Evaluation Module*, unless otherwise noted. When a difference is noted between the two variants, each variant is differentiated as *BQ79616EVM* for the *BQ79616-Q1 Evaluation Module*, and the *BQ75614EVM* for the *BQ75614-Q1 Evaluation Module*. These EVMs are evaluation boards for the *BQ79616-Q1* and *BQ75614-Q1* devices for use in large format lithium-ion battery pack applications to provide monitoring, protecting, balancing, and communications.

Table of Contents

General Texas Instruments High Voltage Evaluation (TI HV EVM) User Safety Guidelines	3
1 General Description	5
1.1 Key Features.....	5
1.2 Key Electrical Parameters.....	5
2 Theory of Operation - Stackable BQ79616EVM	6
2.1 Single Board.....	7
2.2 Stacked Systems.....	7
2.3 Configuring the BQ79616-Q1 EVM to be used for Lower Cell Count Applications.....	7
3 Theory of Operation - Standalone BQ75614EVM	8
4 Connectors	10
4.1 Primary Input and Output Connectors.....	10
5 Quick Start Guide	14
5.1 Required Devices for using the Example Code.....	14
5.2 Power Connections.....	14
5.3 Connecting the EVM to TMS570 LaunchPad.....	15
5.4 Stacking BQ79616EVMs.....	15
5.5 Software.....	15
5.6 GUI.....	16
6 Physical Dimensions	17
6.1 Board Dimensions.....	17
6.2 Board Mounting.....	17
7 BQ79616EVM Schematic, Assembly, Layout, and BOM	18
7.1 Schematic.....	18
7.2 Assembly.....	22
7.3 Layout.....	24
7.4 BQ79616EVM-021 Bill of Materials (BOM).....	33
8 BQ75614EVM Schematic, Assembly, Layout, and BOM	38
8.1 Schematic.....	38
8.2 Assembly.....	42
8.3 Layout.....	43
8.4 BQ75614EVM Bill of Materials (BOM).....	44
9 BQ79656EVM Schematic, Assembly, Layout, and BOM	49
9.1 Schematic.....	49
9.2 Assembly.....	53
9.3 Layout.....	54
9.4 BQ79656EVM Bill of Materials (BOM).....	55

10 Revision History	59
----------------------------------	-----------

Trademarks

LaunchPad™ and Code Composer Studio™ are trademarks of Texas Instruments.
All trademarks are the property of their respective owners.

General Texas Instruments High Voltage Evaluation (TI HV EVM) User Safety Guidelines



WARNING

Warning: To minimize risk of fire hazard, always verify and follow any specific safety instructions and application considerations related to the batteries being used in conjunction with this EVM.

Always follow TI's set-up and application instructions, including use of all interface components within their recommended electrical rated voltage and power limits. Always use electrical safety precautions to help ensure your personal safety and the safety of those working around you. Contact TI's Product Information Center <http://support/ti.com> for further information.

Save all warnings and instructions for future reference.

Failure to follow warnings and instructions can result in personal injury, property damage, or death due to electrical shock and/or burn hazards.

The term TI HV EVM refers to an electronic device typically provided as an open framed, unenclosed printed-circuit-board assembly. This is intended strictly for use in development laboratory environments, solely for qualified professional users having training, expertise, and knowledge of electrical safety risks in development and application of high-voltage electrical circuits. Any other use or application are strictly prohibited by Texas Instruments. If you are not suitably qualified, then immediately stop from further use of the HV EVM.

1. Work Area Safety:

- Keep work area clean and orderly.
- Qualified observers must be present any time circuits are energized.
- Effective barriers and signage must be present in the area where the TI HV EVM and the interface electronics are energized, indicating operation of accessible high voltages can be present, for the purpose of protecting inadvertent access.
- All interface circuits, power supplies, evaluation modules, instruments, meters, scopes and other related apparatus used in a development environment exceeding 50 V_{RMS} or 75 VDC must be electrically located within a protected Emergency Power Off (EPO) protected power strip.
- Use a stable and non-conductive work surface.
- Use adequately insulated clamps and wires to attach measurement probes and instruments. No freehand testing whenever possible.

2. Electrical Safety: As a precautionary measure, a good engineering practice is to assume that the entire EVM can have fully accessible and active high voltages.

- De-energize the TI HV EVM and all the inputs, outputs, and electrical loads before performing any electrical or other diagnostic measurements. Revalidate that TI HV EVM power has been safely de-energized.
- With the EVM confirmed de-energized, proceed with required electrical circuit configurations, wiring, measurement equipment hook-ups and other application needs, while still assuming the EVM circuit and measuring instruments are electrically live.
- Once EVM readiness is complete, energize the EVM as intended.

WARNING

WARNING: while the EVM is energized, never touch the EVM or the electrical circuits as the EVM or the electrical circuits can be at high voltages capable of causing electrical shock hazard.

3. Personal Safety:

- Wear personal protective equipment, for example, latex gloves or safety glasses with side shields or protect EVM in an adequate lucent plastic box with interlocks from accidental touch.

4. Limitation for Safe Use:

- a. EVMs are not to be used as all or part of a production unit.

The following warnings and cautions are noted for the safety of anyone using or working close to the BQ79616 EVM. Observe all safety precautions.

Caution

Do not leave EVM powered when unattended.

Danger High Voltage

The BQ79616EVM is rated as a high voltage EVM, but is not required to operate this EVM at high voltage. If you apply high voltage to this board, then all terminals must be considered high voltage.

Electric shock is possible when connecting the board to live wire. The board must be handled with care by a professional.

For safety, use of isolated test equipment with overvoltage and overcurrent protection is highly recommended.

CAUTION

The circuit module has signal traces, components, and component leads on the bottom of the board. This can result in exposed voltages, hot surfaces, or sharp edges. Do not reach under the board during operation.

CAUTION

The circuit module can be damaged by overtemperature. To avoid damage, monitor the temperature during evaluation and provide cooling, as needed, for your system environment.

CAUTION

Some power supplies can be damaged by application of external voltages. If using more than 1 power supply, check your equipment requirements and use blocking diodes or other isolation techniques, as needed, to prevent damage to your equipment.

CAUTION

The communication interface is not isolated on the EVM. Be sure no ground potential exists between the computer and the EVM. Also be aware that the computer is referenced to the Battery-potential of the EVM.

1 General Description

TI's *BMS021 Battery Management System* (BMS) is an evaluation board for the *BQ7961X-Q1* family of devices for use in large format lithium-ion battery pack applications to provide monitoring, protecting, balancing, and communications. There are two variants of the evaluation board, the *BQ79616EVM* and the *BQ75614EVM*.

Each *BQ79616EVM* can manage up to 16 cells (80-V max) for Li-ion battery applications. Up to 35 *BQ79616EVM* modules can be stacked for packs up to 560 series cells.

Each *BQ75614EVM* can manage 14 or 16 cells (80-V max) for Li-ion battery applications. The standalone *BQ75614EVM* module includes integrated current sense.

Each system provides fast cell balancing, diagnostics, and module to controller communication. Independent protection circuitry is also provided. Please see the *BQ79616-Q1* or *BQ75614-Q1* data sheet for more details on each respective part.

Each EVM is equipped with precision measurement and synchronous communication to enable a controller to perform *State of Charge* (SOC) and *State of Health* (SOH) estimation. Highly-accurate cell voltages and a fast sampling time for the entire battery pack allows more efficient operation of battery modules and more accurate SOC and SOH calculations. Communication with stacked *BQ79616EVMs* is via an isolated daisy-chain differential bus. For the standalone *BQ75614EVM*, SOC and SOH are further assisted by an integrated current sense ADC.

Control a single EVM or multiple stacked EVMs using a PC-hosted GUI. Communication between the PC and the base device in a stack of *BQ79616EVM* (or a single standalone *BQ75614EVM* device) is via a USB2ANY UART interface. For a stack of *BQ79616EVM* devices, communication between all other EVMs in the stack occurs via the isolated, daisy-chain differential communication bus. The PC GUI allows configuration of the EVMs to monitor cells and other analog data channels, control balancing, and monitor details of any faults.

1.1 Key Features

This EVM includes the following features:

- Internal passive cell balancing
- Isolated differential daisy chain communications with optional ring architecture
- Flexible architecture for 6 to 16 cell applications
- UART interface
- High-accuracy cell voltage measurement
- Diagnostics
- 8 multipurpose GPIOs
- Resistor ladder to simulate cell voltages
- Supports Bus Bar Connection/Measurement
- High-accuracy current sense measurement (only available on the *BQ75614EVM*).

1.2 Key Electrical Parameters

The following table identifies the key electrical parameters:

Parameter	Value
Maximum battery pack voltage (stacked EVMs)	2400 V
Maximum operating voltage	80 V (depends on series R3, R4 value)
Minimum operating voltage	9 V (depends on series R3, R4 value, by default use at least 18V)
Maximum cell open circuit voltage	5 V
Ambient temperature	-40 °C to 105 °C
Nominal operating temperature	-20 °C to 60 °C
Cell balancing current	Approximately 200 mA @ 80 °C

2 Theory of Operation - Stackable BQ79616EVM

Figure 2-1 shows the system stack diagram.

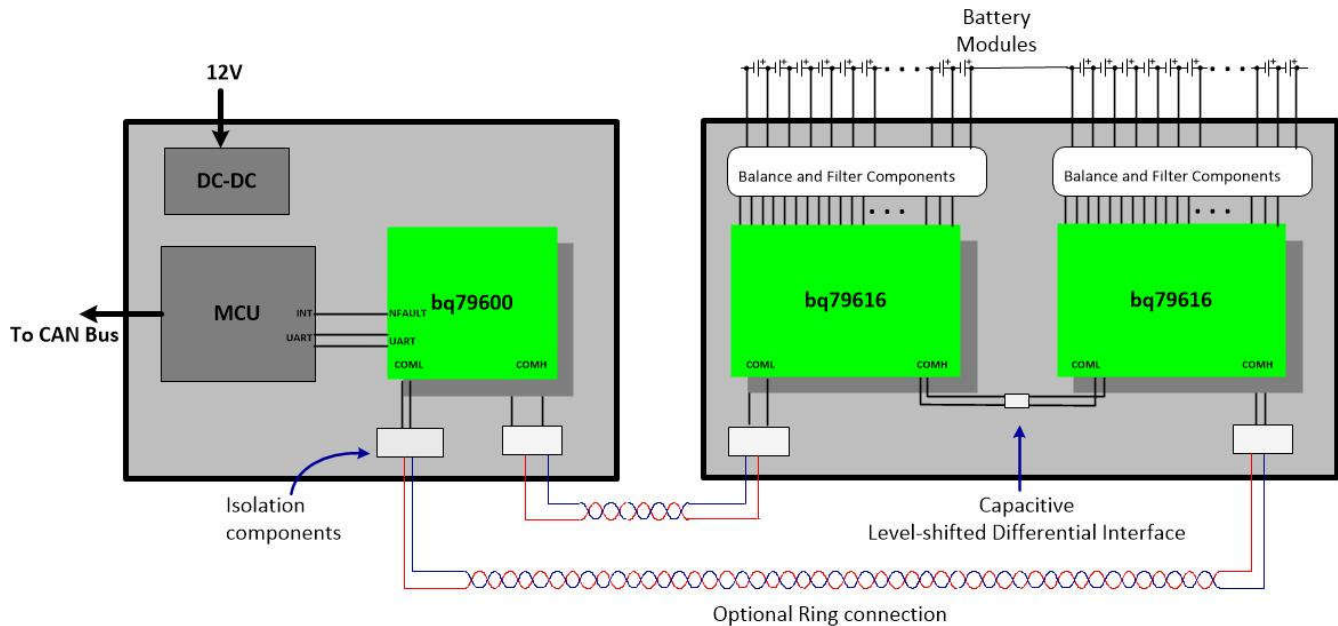

Figure 2-1. System Block Diagram - BQ79616

The BMS system is designed to prolong the useful life of lithium-ion cells in battery packs through passive balancing. The battery pack is broken into a series of modules, each of which contains up to 16 cells. This system monitors voltages of individual battery cells and dissipates individual cell voltages through the use of internal cell balancing FETs. The BMS allows battery-powered electric machines to use smaller battery packs and fewer charging cycles to perform the same amount of work. The BMS also improves the overall lifetime of Li-ion battery packs by preventing undervoltage and overvoltage damage from occurring.

The typical BMS system with stacked modules has three main sub-systems, as shown in Figure 2-1:

- Host controller - in this case a TMS570 LaunchPad™
- A BQ79616-Q1 configured as an isolated communication bridge device - a BQ79600EVM or another BQ79616EVM can support this
- BQ79616EVM based modules attached to cells - these can be stacked up to 35 total (including the bridge device)

All commands and data are communicated with a host through either a UART or daisy-chain communication connection. The BQ79616 remains idle until a command is received from the host. The BQ79616 can support a host PC or microcontroller (via the UART connection header) or a daisy-chain interface from a BQ79616-Q1 implemented as a communication bridge.

The typical flow is for the host to go through the following simplified sequence:

1. Wakeup the BQ79616EVM board by sending a WAKEUP pulse when using the UART interface, or sending a WAKE tone when using the BQ79616EVM in a stack of other BQ79616EVM boards for a large battery pack or a BQ79616-Q1 configured as a bridge. Initialize the BQ79616-Q1 to be ready for use.
2. Send a sample command to the BQ79616-Q1 to read the cell measurement results.
3. The host uses the cell measurement data to calculate an average and determine the highest or lowest cells and determine the cells that are balanced.
4. If no stop command is sent, then the BQ79616-Q1 has a built-in timeout (set by the user), after which time the discharge is stopped automatically.
5. The host can then decide to repeat the process (back to step 2) or send commands to shutdown the BQ79616EVM and return later.

2.1 Single Board

As a single board the BMS can passively balance up to 16 cells, up to 80 V of total voltage. Communication to the BQ79616EVM is handled by the daisy-chain communications bus from another BQ79616-Q1 or the UART host interface.

2.2 Stacked Systems

The boards can be stacked in daisy chain to accommodate larger battery packs than the 16 channels provide on a single board. Communication to the BQ79616EVM is handled by the daisy-chain communications bus from another BQ79616-Q1.

2.3 Configuring the BQ79616-Q1 EVM to be used for Lower Cell Count Applications

The BQ79616-Q1 EVM can be configured to support lower cell count applications, especially for users designing with the BQ79614-Q1/BQ79612-Q1 devices. For these cases, the EVM comes fitted with placeholder 0 ohm resistors for shorting together the VC and CB pins of the topmost cells. These can be found in the schematic at the bottom of this user guide, with a note *Resistors for Lower Cell Count Applications*. The user needs to populate the 0 ohm resistors depending on the use of 12 or 14 cells. For 14, the user populates only R24, R28, R22, and R26, whereas for 12 the user populates all 8 of the resistors (R24, R28, R22, R26, R21, R23, R25, R27). The GUI is also implemented with a feature to change the active cell configuration. Navigate to the cell monitor page to *View Poll Settings* and then select their desired active cell configuration by using the dropdown selection below the *No. of cells* column.

3 Theory of Operation - Standalone BQ75614EVM

Figure 3-1 shows the system block diagram.

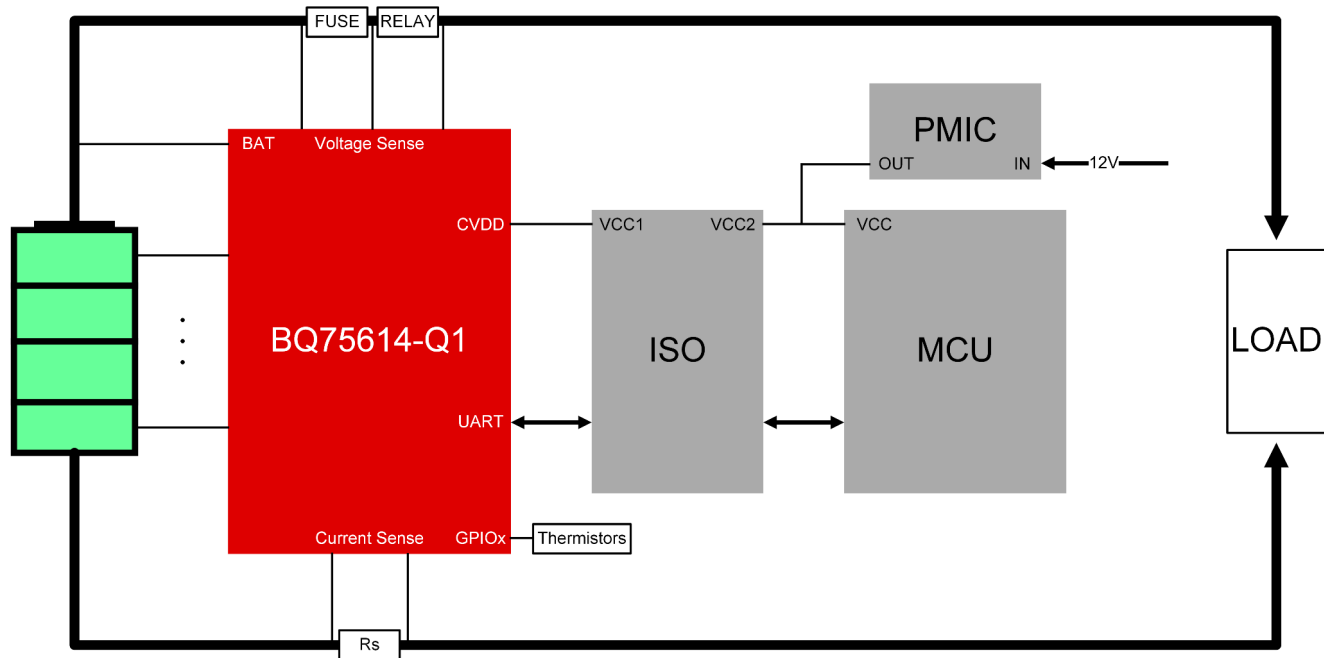

Figure 3-1. System Block Diagram - BQ75614

The BMS system is designed to prolong the useful life of lithium-ion cells in battery packs through passive balancing, and provide enhanced SOC and SOH measurements using integrated current sense measurement. The device can monitor a battery pack which contains up to 16 cells, or up to 14 cells with the ability to measure fuse and relay voltages. This system monitors voltages of individual battery cells and dissipates individual cell voltages through the use of internal cell balancing FETs. The BMS allows battery-powered electric machines to use smaller battery packs and fewer charging cycles to perform the same amount of work. The BMS also improves the overall lifetime of Li-ion battery packs by preventing undervoltage and overvoltage damage from occurring.

The typical BMS system with integrated current sense has two main sub-systems, as shown in Figure 3-1:

- Host controller - in this case a TMS570 LaunchPad™
- BQ75614EVM module attached to cells, and communicating with the host
- Optional: a digital isolator between the host domain and the BQ75614EVM domain

All commands and data are communicated with a host through UART. The BQ75614-Q1 remains idle until a command is received from the host. The BQ75614EVM can support a host PC or microcontroller (via the UART connection header).

The typical flow is for the host to go through the following simplified sequence:

1. Wakeup the BQ75614EVM board by sending a WAKEUP pulse when using the UART interface.
2. Send a sample command to the BQ75614-Q1 to read the cell measurement results and current measurement results.
3. The host uses the cell measurement data to calculate an average and determine the highest or lowest cells and determine the cells that are balanced. The host uses the current measurement data to estimate SOC and SOH.
4. If no stop command is sent, then the BQ75614-Q1 has a built-in timeout (set by the user), after which time the discharge is stopped automatically.
5. The host can then decide to repeat the process (back to step 2) or send commands to shutdown the BQ75614EVM and return later.

As a single standalone board, the BQ75614EVM can passively balance up to 16 cells, up to 80 V of total voltage. Communication to the BQ75614EVM is handled by the UART host interface.

4 Connectors

4.1 Primary Input and Output Connectors

4.1.1 Jumper Placements

Below is a table explaining each of the jumpers available for the user's flexibility.

Pinheader	Contacts	Jumper Connection	Populated by Default?
J1	1-2	Rx direct connection to CVDD	No
J2	1-2	NFAULT connection to Digital Isolator	Yes
J4	1-2	GPIO1 connection to 10k pullup and thermistor	Yes
J5	1-2	TSREF pullup to GPIOs	Yes
J6	1-2	LED connection on AVDD to indicate the device is awake	Yes
J14	1-2	PWR/BAT connection to CELL16	Yes
J16	1-2	CELL0 connection to GND	Yes
J18	1-2	CVDD connection to Digital Isolator	Yes
J21	1-2	RX to Dig Isolator Connection	Yes

To set up the EVM as a base or stack device, the following jumper configurations need to be made:

- If the EVM is being used as a base device, then populate J2, J18, and J21, but remove J1.
- If the EVM is being used as a stack device, then populate J1, but remove J2, J18, and J21.

4.1.2 Battery Connector

The live battery cell connections are made from connector J15. Cell voltage measurements and balancing currents use these connections. Alternatively, the user can simulate cell voltages using the on board resistor ladder across each of the cells, which can be utilized by closing switches S1 and S2 and applying a DC voltage across the VSTACK test point and GND. Short unused channels to the top cell connection in the wiring harness to support fewer than 16 cells. At the minimum, the user must support 6 cells. Additional instructions for the connections for wiring J15 to live battery cells can be found in [Figure 7-3](#).



Figure 4-1. Molex 50-57-9422 (Reference Image Only)

Table 4-1. Connector Information

Designator	Manufacturer	Part Number	Mating Connector
J15	Molex	Manufacturer:0705550056 Digi-Key: 0705550056-ND	Manufacturer:50-57-9422 Digi-Key:WM2920-ND

Table 4-2. Pin Description

Pin	Name	Comments
1	CELL0/GND	Negative terminal of CELL1, Connected directly to AVSS GND of device
2	CELL16	Positive terminal of CELL16, Direct connection to BAT, LDOIN
3	CELL0	Negative terminal of CELL1, Connected directly to AVSS GND of device
4	CELL0S	Negative terminal of CELL1, Actual sense connection for VC0 path
5	CELL1	Positive terminal of CELL1, negative terminal of CELL2
6	CELL2	Positive terminal of CELL2, negative terminal of CELL3
7	CELL3	Positive terminal of CELL3, negative terminal of CELL4
8	CELL4	Positive terminal of CELL4, negative terminal of CELL5
9	CELL5	Positive terminal of CELL5, negative terminal of CELL6
10	CELL6	Positive terminal of CELL6, negative terminal of CELL7
11	CELL7	Positive terminal of CELL7, negative terminal of CELL8
12	CELL8	Positive terminal of CELL8, negative terminal of CELL9
13	CELL9	Positive terminal of CELL9, negative terminal of CELL10
14	CELL10	Positive terminal of CELL10, negative terminal of CELL11
15	CELL11	Positive terminal of CELL11, negative terminal of CELL12
16	CELL12	Positive terminal of CELL12, negative terminal of CELL13
17	CELL13	Positive terminal of CELL13, negative terminal of CELL14
18	CELL14	Positive terminal of CELL14, negative terminal of CELL15
19	CELL15	Positive terminal of CELL15, negative terminal of CELL16
20	CELL16S	Positive terminal of CELL16, actual sense connection to VC16 path
21	CELL16	Positive terminal of CELL16, Direct connection to BAT, LDOIN
22	CELL0/GND	Negative terminal of CELL1, Connected directly to AVSS GND of device

4.1.3 Host Interface

The 10-pin J17 - Serial connector is used to connect the EVM to a PC running the GUI or to a host controller. Texas Instruments recommends using the USB2ANY that is available to order through TI.com, which includes the proper 10 pin cable.

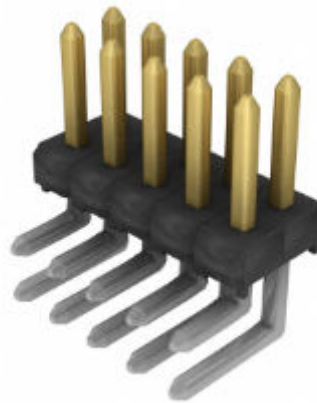

Figure 4-2. Samtec Inc. TSW-105-08-L-D-RA (Reference Image Only)

Table 4-3. Connector Information

Designator	Manufacturer	Part Number	Mating Connector
J17	Samtec Inc.	Manufacturer: TSW-105-08-L-D-RA	10 pin ribbon connector packaged with USB2ANY

Table 4-4. Pin Description

Pin	Name
1	NC
2	NC
3	$\overline{\text{nFAULT}}$ signal from BQ79616-Q1 or BQ75614-Q1
4	NC
5	GND
6	USB2ANY 3.3V
7	USB2ANY TX (RX of BQ79616-Q1 or BQ75614-Q1)
8	USB2ANY RX (TX of BQ79616-Q1 or BQ75614-Q1)
9	NC
10	NC

4.1.4 GPIO or Thermistor Inputs

There are 8 GPIO pins, which can either be floated, connected to a thermistor and 10k pullup, or forced to certain voltage for a measurement. This can be determined by using the J4 header as shown below. Insert a shunt from pins 1 and 2 to connect GPIO1 to the thermistor, pins 3 and 4 to connect GPIO2 and so on for the other GPIOs. Jumper J5 must also be connected to pull the GPIOs up to the TSREF reference voltage for ratiometric NTC measurements.

**Figure 4-3. Sullins Connector Solutions PEC08DAAN (Reference Image Only)****Table 4-5. Connector Information**

Designator	Manufacturer	Part Number	Mating Connector
J4	Sullins Connector Solutions	Manufacturer: PEC08DAAN	N/A

Table 4-6. Pin Description - J4

Pin	Name	Comments
1	GPIO1	GPIO1 Pin of BQ79616-Q1 or BQ75614-Q1
2	GPIO1_R	Connection for GPIO1 to 10k pullup and thermistor
3	GPIO2	GPIO2 Pin of BQ79616-Q1 or BQ75614-Q1
4	GPIO2_R	Connection for GPIO2 to 10k pullup and thermistor
5	GPIO3	GPIO3 Pin of BQ79616-Q1 or BQ75614-Q1
6	GPIO3_R	Connection for GPIO3 to 10k pullup and thermistor
7	GPIO4	GPIO4 Pin of BQ79616-Q1 or BQ75614-Q1
8	GPIO4_R	Connection for GPIO4 to 10k pullup and thermistor
9	GPIO5	GPIO5 Pin of BQ79616-Q1 or BQ75614-Q1
10	GPIO5_R	Connection for GPIO5 to 10k pullup and thermistor
11	GPIO6	GPIO6 Pin of BQ79616-Q1 or BQ75614-Q1
12	GPIO6_R	Connection for GPIO6 to 10k pullup and thermistor
13	GPIO7	GPIO7 Pin of BQ79616-Q1 or BQ75614-Q1
14	GPIO7_R	Connection for GPIO7 to 10k pullup and thermistor
15	GPIO8	GPIO8 Pin of BQ79616-Q1 or BQ75614-Q1
16	GPIO8_R	Connection for GPIO8 to 10k pullup and thermistor

4.1.5 High-Side and Low-Side Communications

There are two sets of 4-position molex connectors available on each BQ79616EVM board. These are not available on the BQ75614EVM. These provide high-side (J11) and low-side (J10) communications between stacked EVM devices.

Table 4-7. Connector Information

Designator	Manufacturer	Part Number	Mating Connector
J10/J11	Molex	Manufacturer: 0705510038 Digi-Key: WM14059-ND	Manufacturer: 0050579404 Digi-Key: WM2902-ND

Table 4-8. Pin Description - J10

Pin	Name	Comments
1	COML_N	COM lowside negative
2	COML_P	COM lowside positive
3	N/A	Unused
4	N/A	Unused

Table 4-9. Pin Description - J11

Pin	Name	Comments
1	N/A	Unused
2	N/A	Unused
3	COMH_P	COM highside positive
4	COMH_N	COM highside negative

5 Quick Start Guide

This section includes hardware setup instructions, connection procedures, and software and GUI instructions.

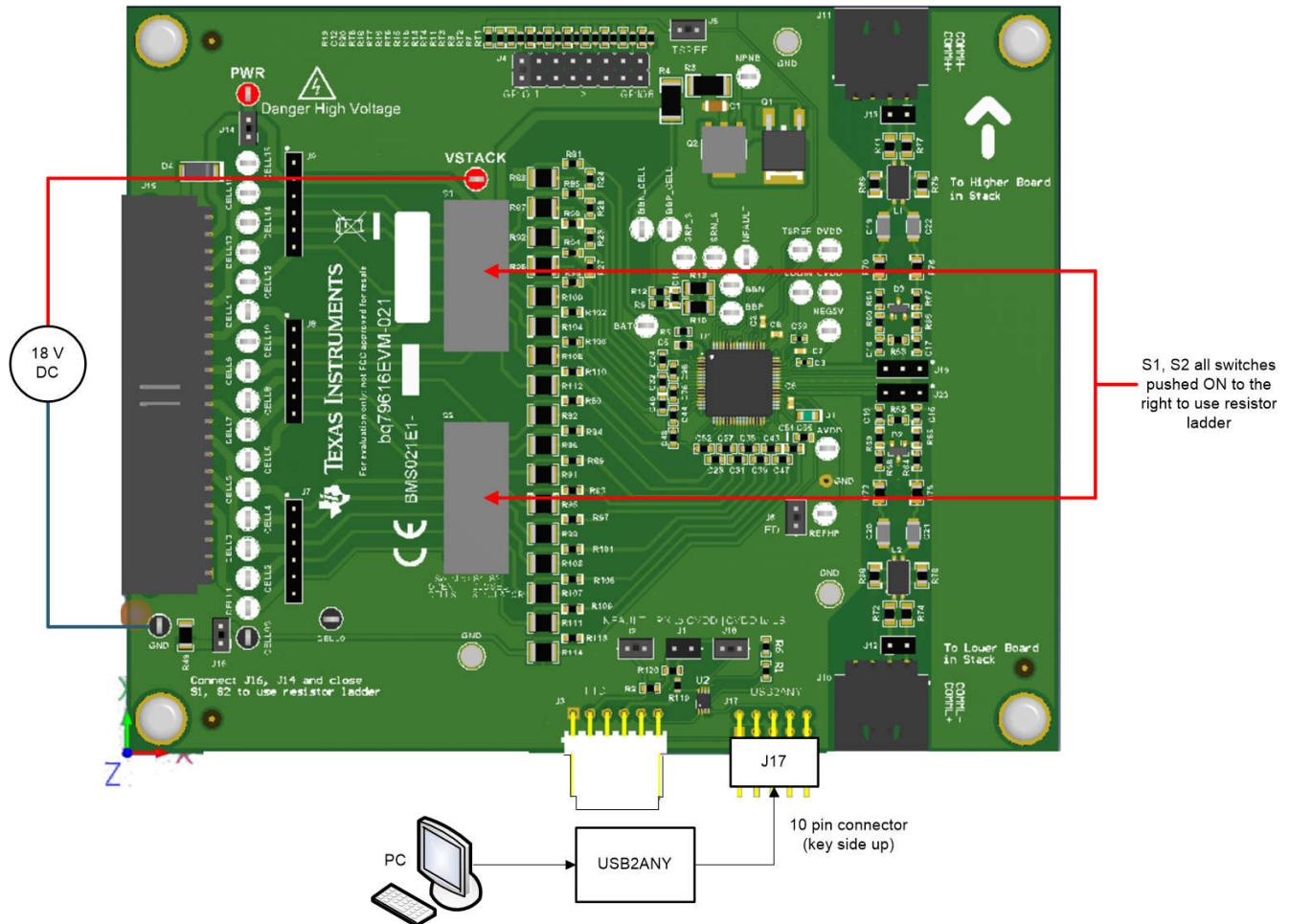

Figure 5-1. Basic EVM Setup using DC Voltage with Resistor Ladder

5.1 Required Devices for using the Example Code

The system example code is implemented using the TMS570LS12 LaunchPad™ board (TMS570LS1224 MCU) and the BMS021 via Code Composer Studio.

The part numbers of the evaluation modules are LAUNCHXL2-TMS57012 and BQ79616EVM-021 (for BQ79616-Q1 evaluation) or BQ75614EVM-021 (for BQ75614-Q1 evaluation). These boards are available from the TI eStore (<https://estore.ti.com/>) or from your local TI sales representative. For more details and information related to the LaunchPad modules, see the specific module user's guide.

5.2 Power Connections

If powering the EVM using the included resistor ladder as cells, simply ensure that the power supply positive terminal is connected to the "VSTACK" or "PWR" testpoints provided on the board, and the power supply negative terminal is connected to the "GND" or "Cell0" testpoints provided on the board, or any "GND" standoff provided.

If not using the resistor ladder, the power supply positive terminal must be connected to the "PWR" testpoint, and the power supply negative terminal must be connected to the "Cell0" testpoint.

Also ensure that headers J16 and J14 are both jumpered, to allow for power and ground to be supplied from the "battery stack" (resistor ladder).

5.2.1 On-Board Resistor Ladder - Power Supply

Each EVM utilizes an on-board resistor ladder to simplify the evaluation process. Each of the sixteen resistors is nominally 100 Ω , resulting in roughly one-sixteenth of the module voltage at each cell connection. For the BQ75614EVM, this is one-fourteenth the module voltage as the board does not use the top two cells. By default, all actuators of S1, S2 are positioned closest to the IC, which is the "ON" or "closed" state. In this state, all of the resistors are connected to the EVM sense and balance connections and allow easy start up with a DC voltage connection across VSTACK and GND.

To simulate connected cells to the sense and balance connections (using a power supply), ALL switch actuators on S1, S2 must be moved away from the module connector J15 if not already done. Moving the actuators in this manner connects the EVM to the resistor ladder, and allows for simulated cell measurements.

5.2.2 Using Actual Battery Cells

When using actual battery cells, disconnect the resistor ladder by moving ALL switch actuators on S1, S2 to the "OFF" or open position (away from the IC and towards J15).

5.3 Connecting the EVM to TMS570 LaunchPad

The EVMs are connected using a standard wire jumper; [Table 5-1](#) shows the connections between the two EVMs. By default, the TMS570 LaunchPad is powered by the USB port on the host computer.

Table 5-1. *Connections Between EVM and TMS570 LaunchPad

Connection Name	EVM	TMS570 LaunchPad
TX	J17 Pin	J2 pin 3 (UARX)
RX	J17	J2 pin 4 (UATX)
nFAULT	J17	J2 pin 5 (PA7)
GND	J17	J3 pin 2 (GND)

5.4 Stacking BQ79616EVMs

Note

This section does not apply to BQ75614EVMs.

The BQ79616EVMs are connected using 4-position Molex connectors. There is a high side (J11) and low side (J10) communication connector available on each device. By default, the isolation filters for the vertical interface are set to cap only configuration. The user can change this by populating/depopping components. For example, the user can depopulate resistors R69, R79, R72, and R74 to use the on board choke in series with the capacitors. There are also footprints to populate a transformer on the bottom of the PCB board. More details can be found in the schematic near the bottom of this user guide.

Table 5-2. Connections Between High-Side/Low-Side BQ79616EVMs

Connection Name	BQ79616EVM High Side	BQ79616EVM Low Side
COMH_N/COML_N	J11 pin 4	J10 pin 1
COMH_P/COML_P	J11 pin 3	J10 pin 2

5.5 Software

The software provides a command API and drivers that are capable of implementing the examples provided in *BQ79616-Q1 Software Design Reference*.

The example code only provides a control interface to the BQ79616-Q1 and does not provide any other communications interface to the outside world. The customer is expected to develop their own communication implementation. Examples of communications interfaces available to the TMS570 are SPI, CAN, or UART. For the TMS570 example code, UART is the communication protocol used between the microcontroller and BQ79616-Q1 device.

This firmware provided with this application note provides source code examples of the command sequences described in the *BQ79616-Q1 Software Design Reference*.

Importing a project into Code Composer Studio™:

1. Launch the provided file: *BQ79616-Q1 Example Code 0.1 Installer.exe* and extract files to the default path provided (C:\ti\bq79616-Q1 Example Code 0.1).
2. Launch *Code Composer Studio* (CCS):
Start → **Programs** → **Texas Instruments** → **Code Composer Studio v8** → **Code Composer Studio v8**.
3. When *Code Composer Studio* launches, CCS requests a workspace is selected, choose "C:\myWorkspace".
Once CCS loads, go to:
Project → **Import CSS Projects...** → **Select search-directory**.
4. In *Select search-directory*, browse to the folder:
C:\ti\bq79616-Q1 Example Code 0.1 .
5. In *Discovered projects*:, check BQ79616-Q1 example code.

5.6 GUI

An initial evaluation can be more beneficial to use the graphical user's interface (GUI), which provides a *point and click* interface to become familiar with the BQ79616-Q1 or BQ75614-Q1. During the initial sampling phase, please contact your local TI FAE to get the latest GUI version.

To get started with the GUI, please refer to the *BQ79616 GUI User Guide* ([SLUUC36](#)) document.

5.6.1 GUI UART Connection

The physical setup for the GUI is the same as for the microcontroller, but uses an USB2ANY interface and 10 pin cable for the UART connections on J17 instead. The USB2ANY has a USB Mini-B connector on the right side. Plug the provided USB cable (or any USB cable with a Mini-B connector) into the USB2ANY. Plug the other end of the cable (USB 'A') into the computer. Then connect the 10 pin connector cable to J4 of the USB2ANY (middle most connector). The key side must be facing upwards when connecting to the EVM header J17. Please refer to the picture below and this is explained in more detail in the USB2ANY user's guide ([SNAU228](#)) and the BQ79616-Q1 GUI User's Guide ([SLUUC36](#)).

6 Physical Dimensions

6.1 Board Dimensions

Board dimensions: 4.400 in × 5.500 in

Board height:

- Top - Tallest component (GPIO, Shunts) is 0.35 in (8.8 mm) above PCB.
- Bottom - Tallest component if populated (Transformers) is 0.41 in (10.5 mm) above PCB (Depopulated by default).

6.2 Board Mounting

Figure 6-1 illustrates the EVM dimension drawing.

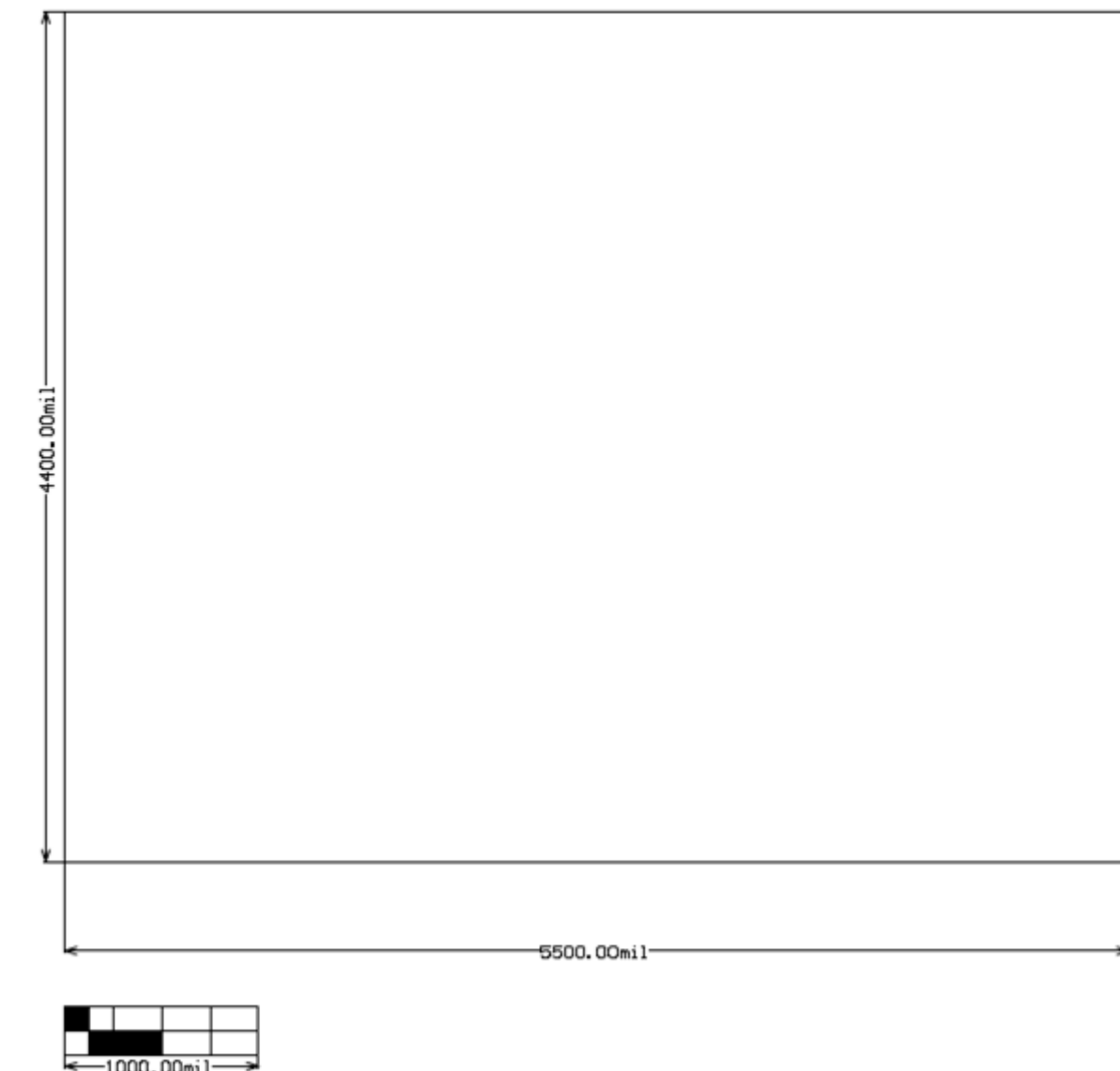

Figure 6-1. Board Dimensions

7 BQ79616EVM Schematic, Assembly, Layout, and BOM

Provided are the BQ79616EVM schematic, assembly, layout and BOM in their respective sections.

7.1 Schematic

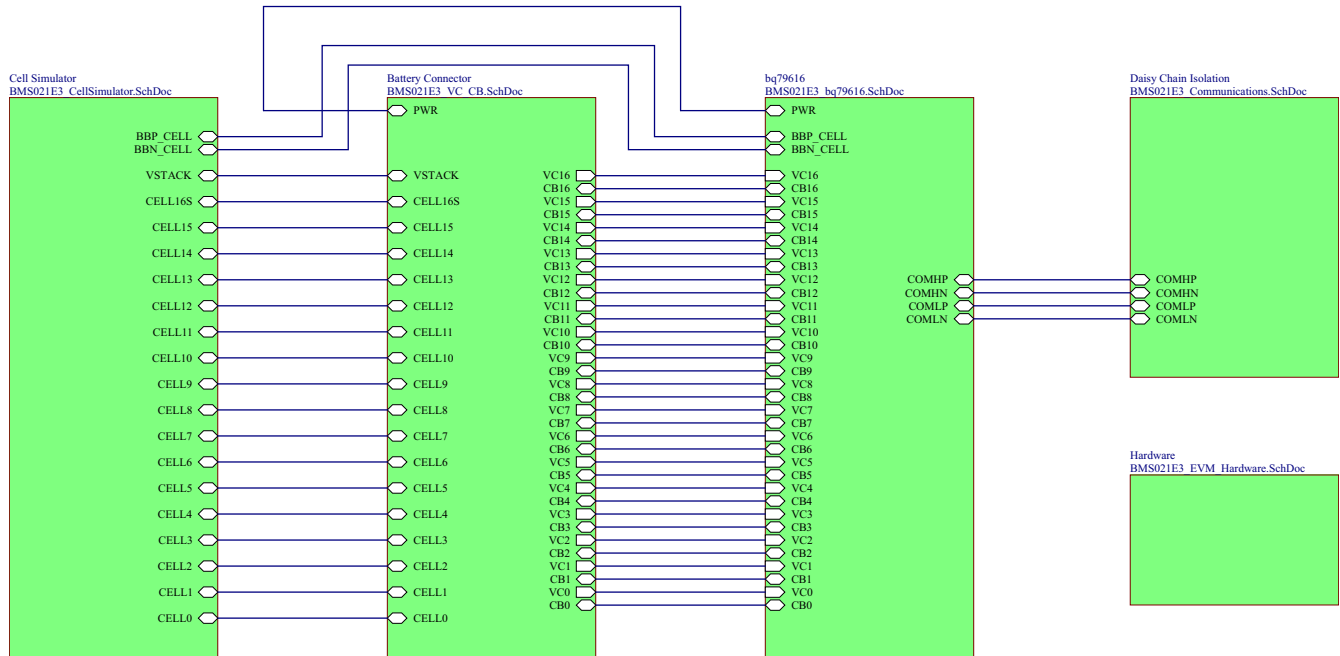

Figure 7-1. BQ79616EVM Schematic Block Diagram

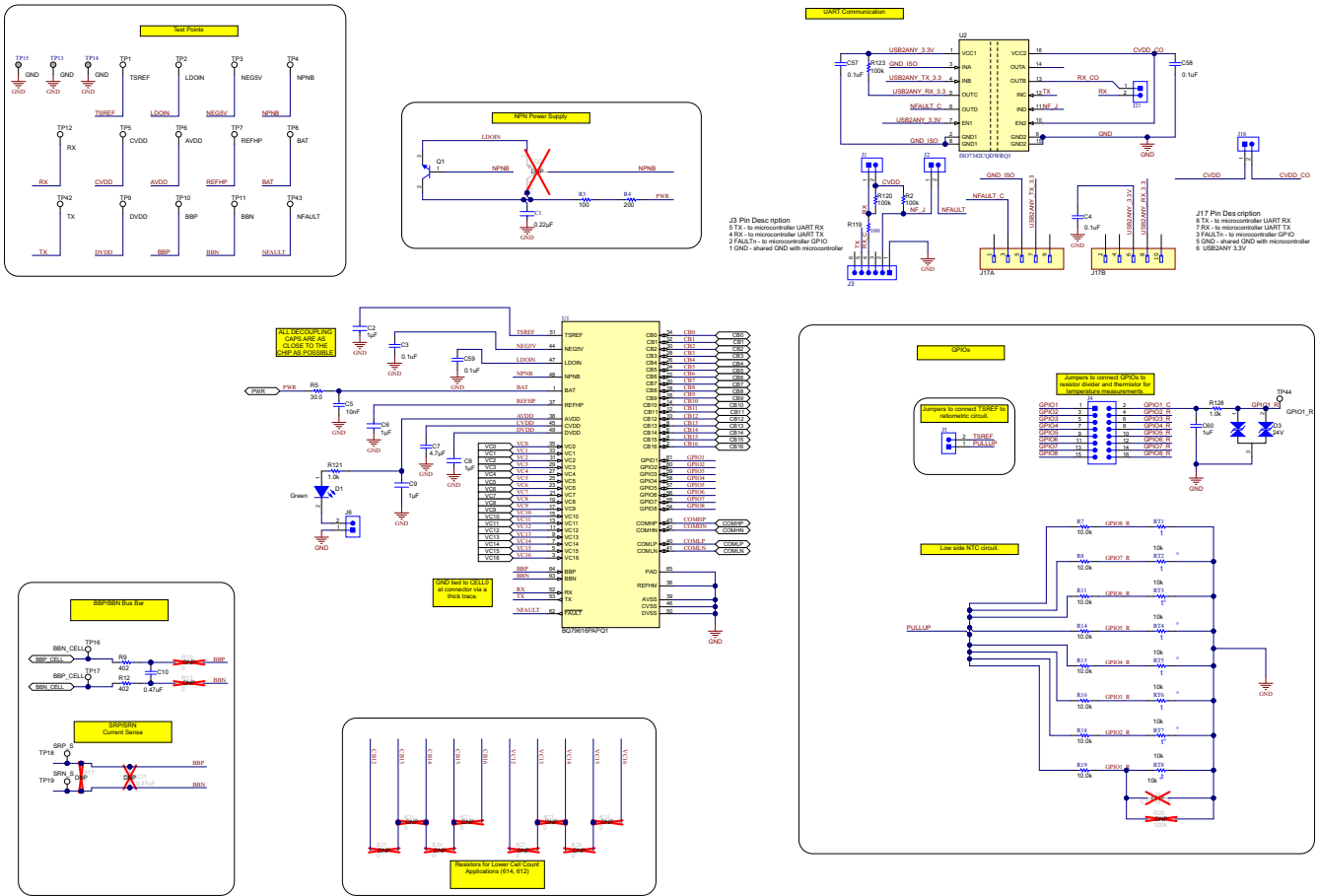
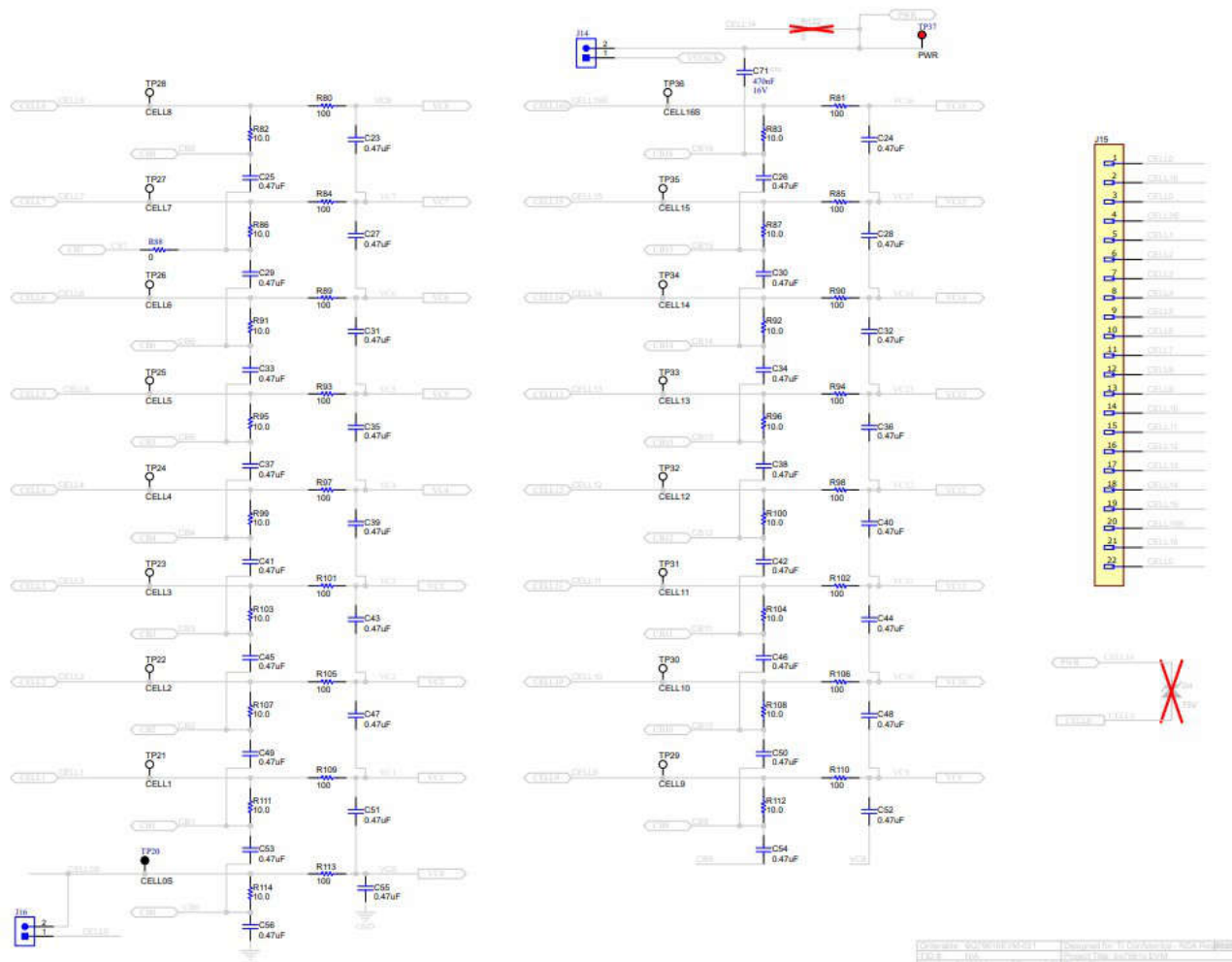

Figure 7-2. BQ79616EVM Schematic Part 1



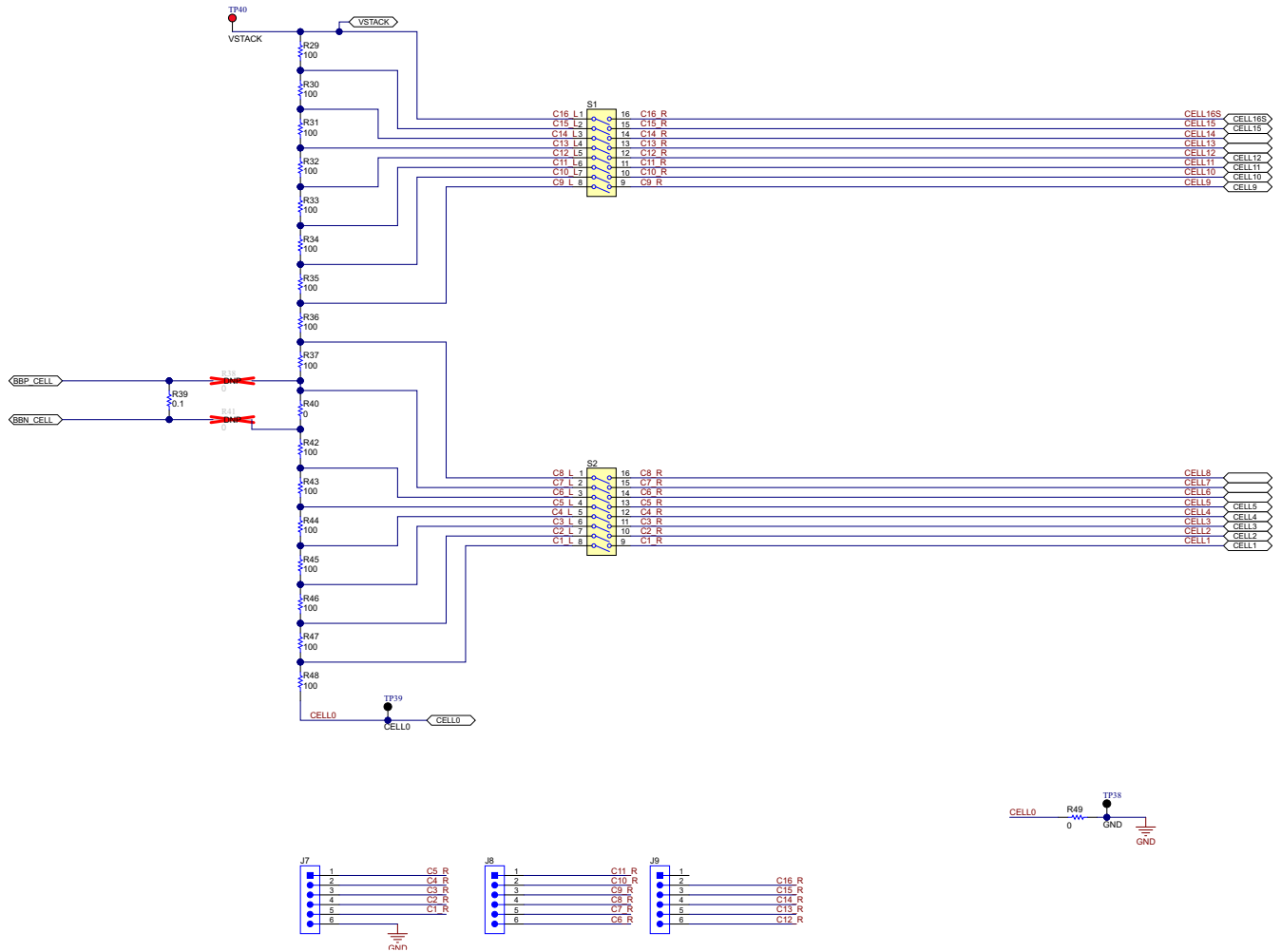

Figure 7-4. BQ79616EVM Schematic Part 3

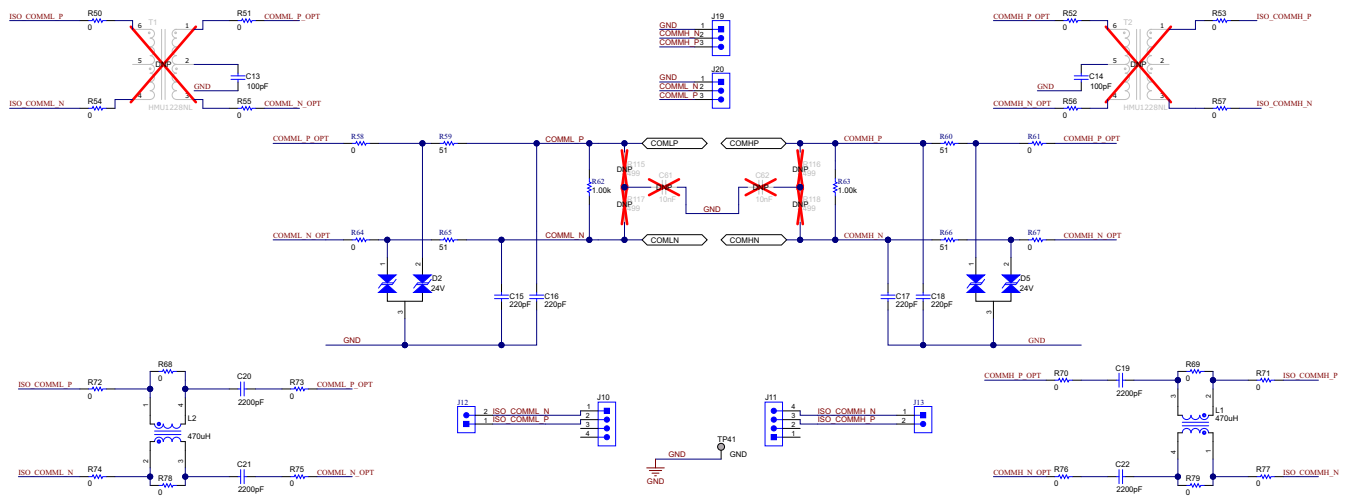
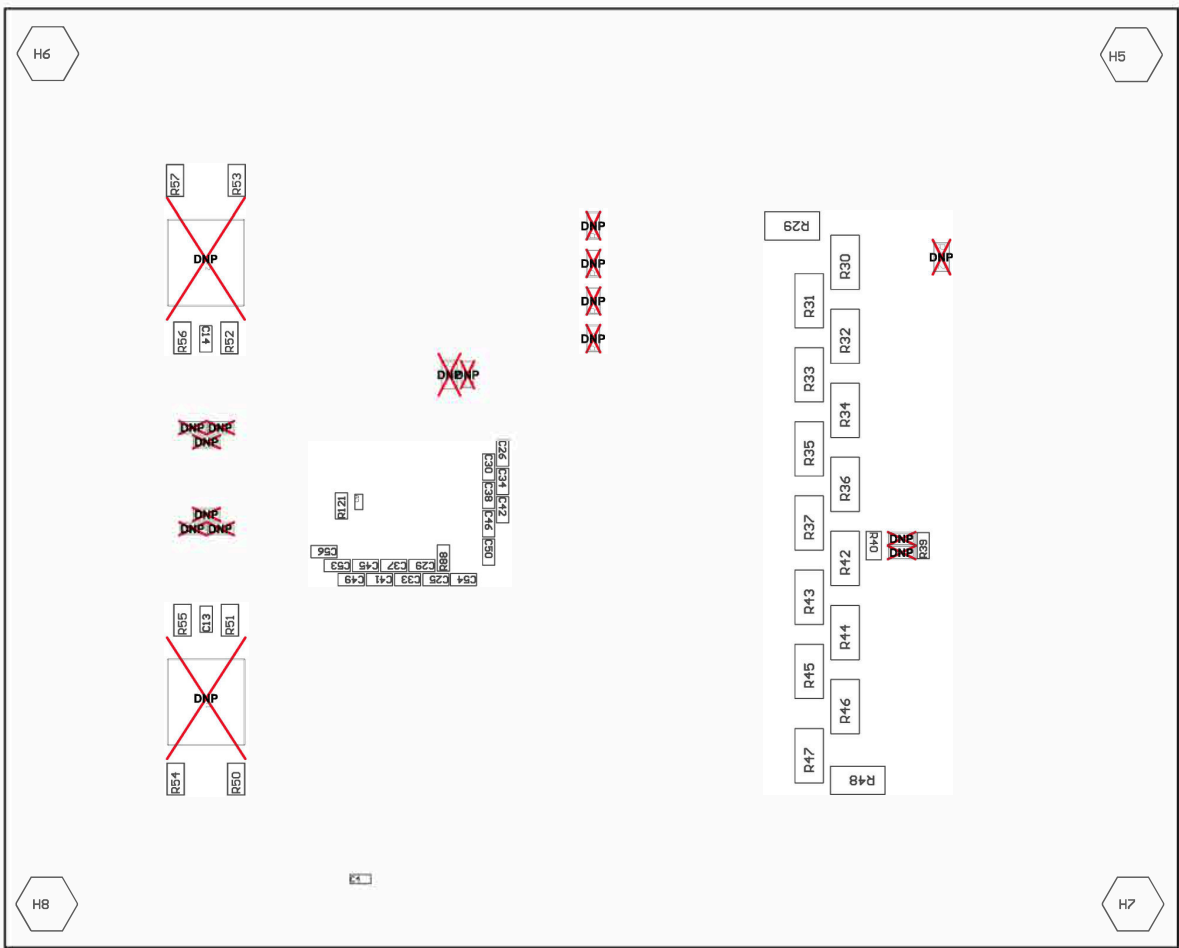

Figure 7-5. BQ79616EVM Schematic Part 4



COMPONENTS MARKED 'DNP' SHOULD NOT BE POPULATED.
 ASSEMBLY VARIANT: 001

Figure 7-7. BQ79616EVM Assembly Bottom

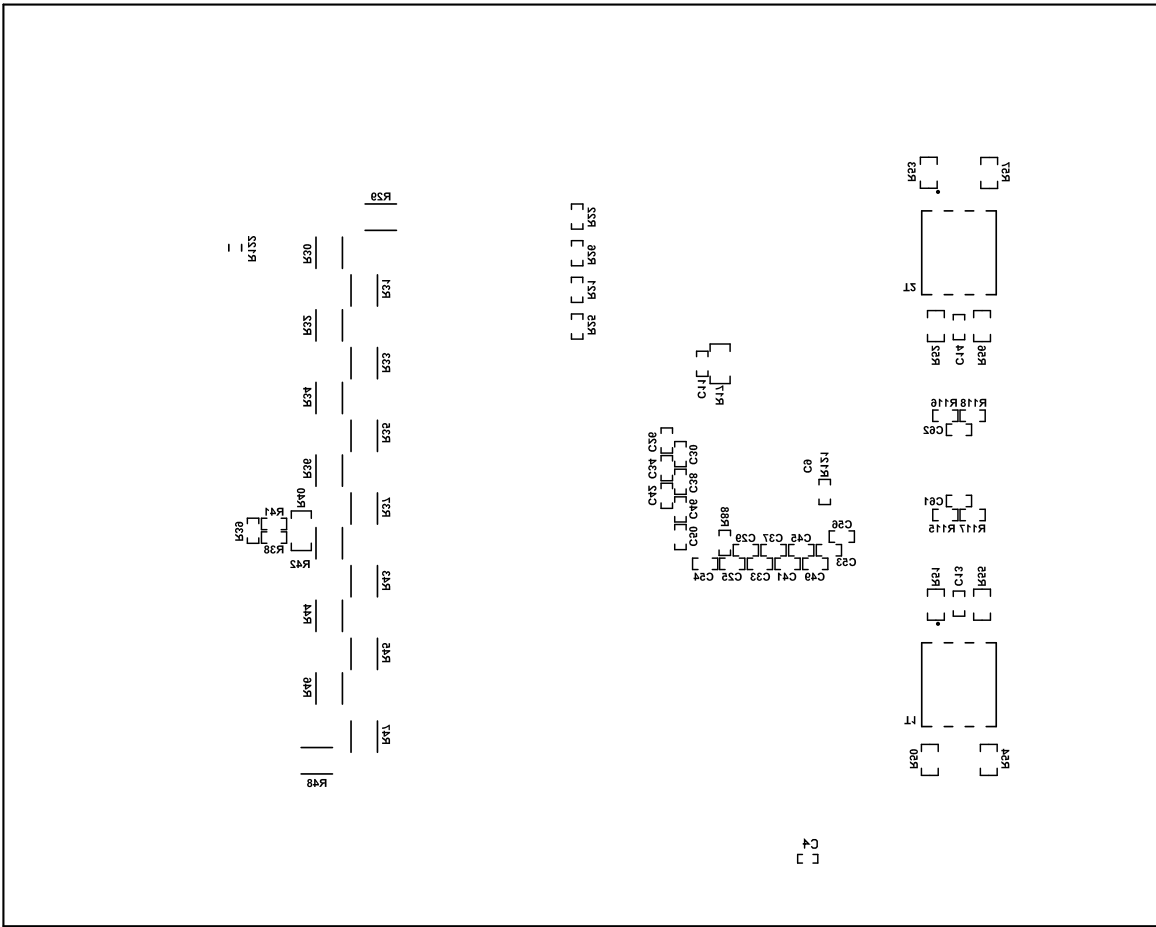

Figure 7-9. BQ79616EVM Bottom Overlay

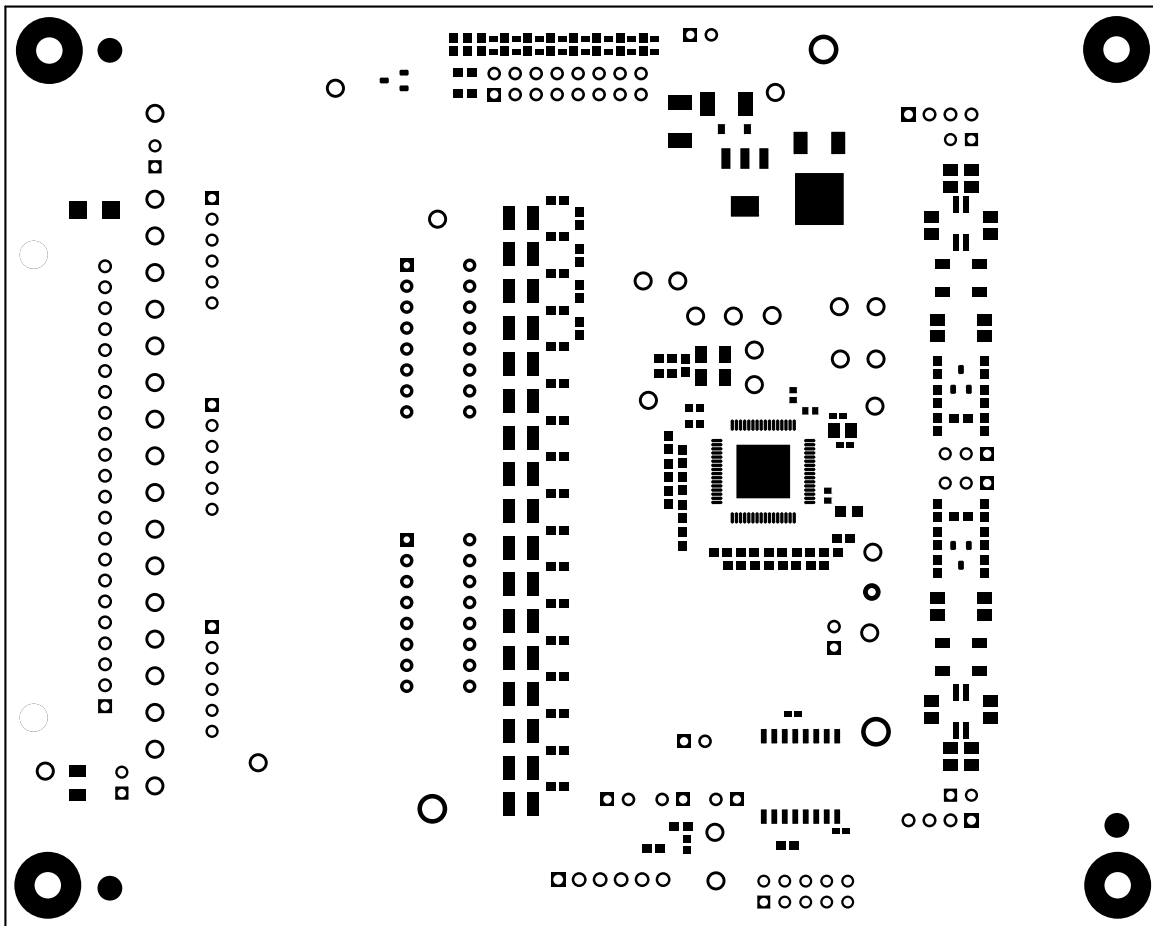

Figure 7-10. BQ79616EVM Top Solder

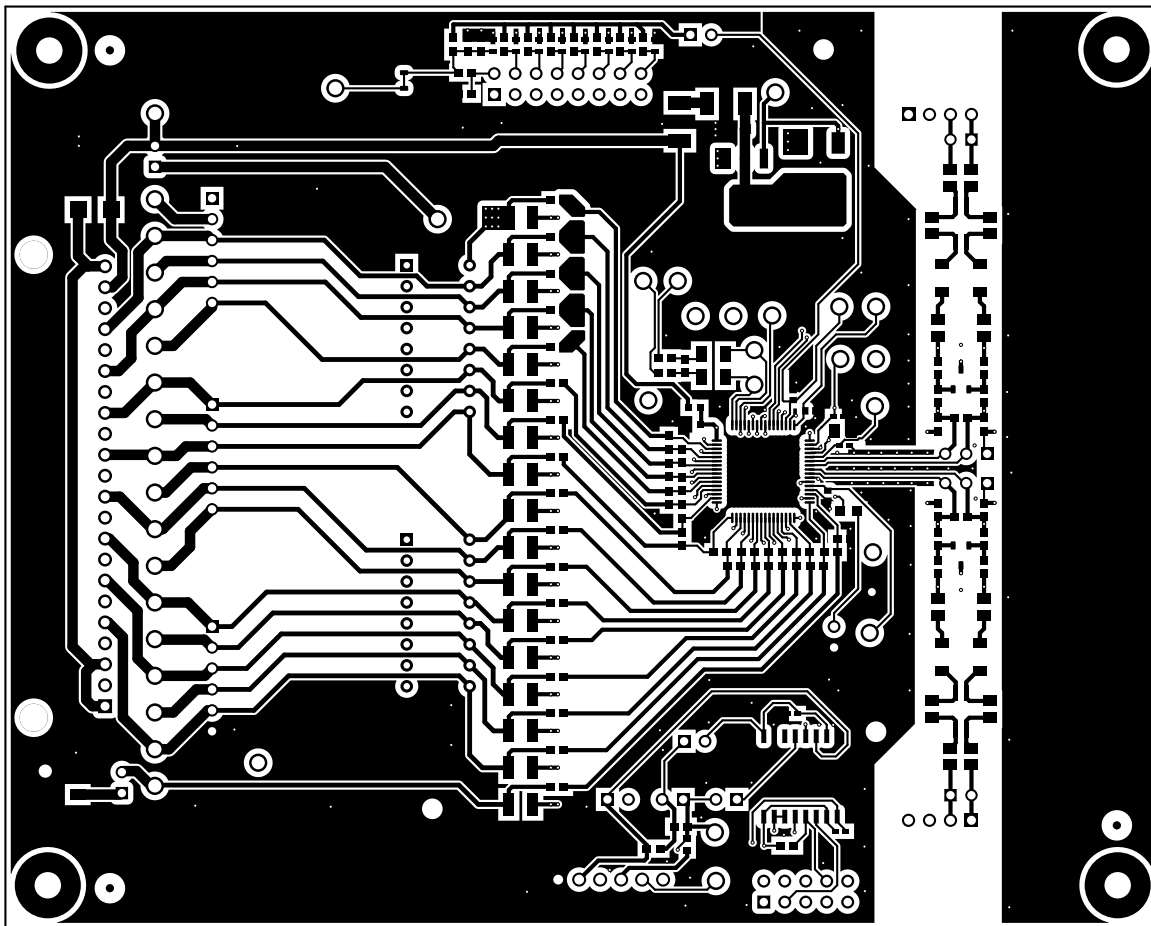

Figure 7-11. BQ79616EVM Top Layer

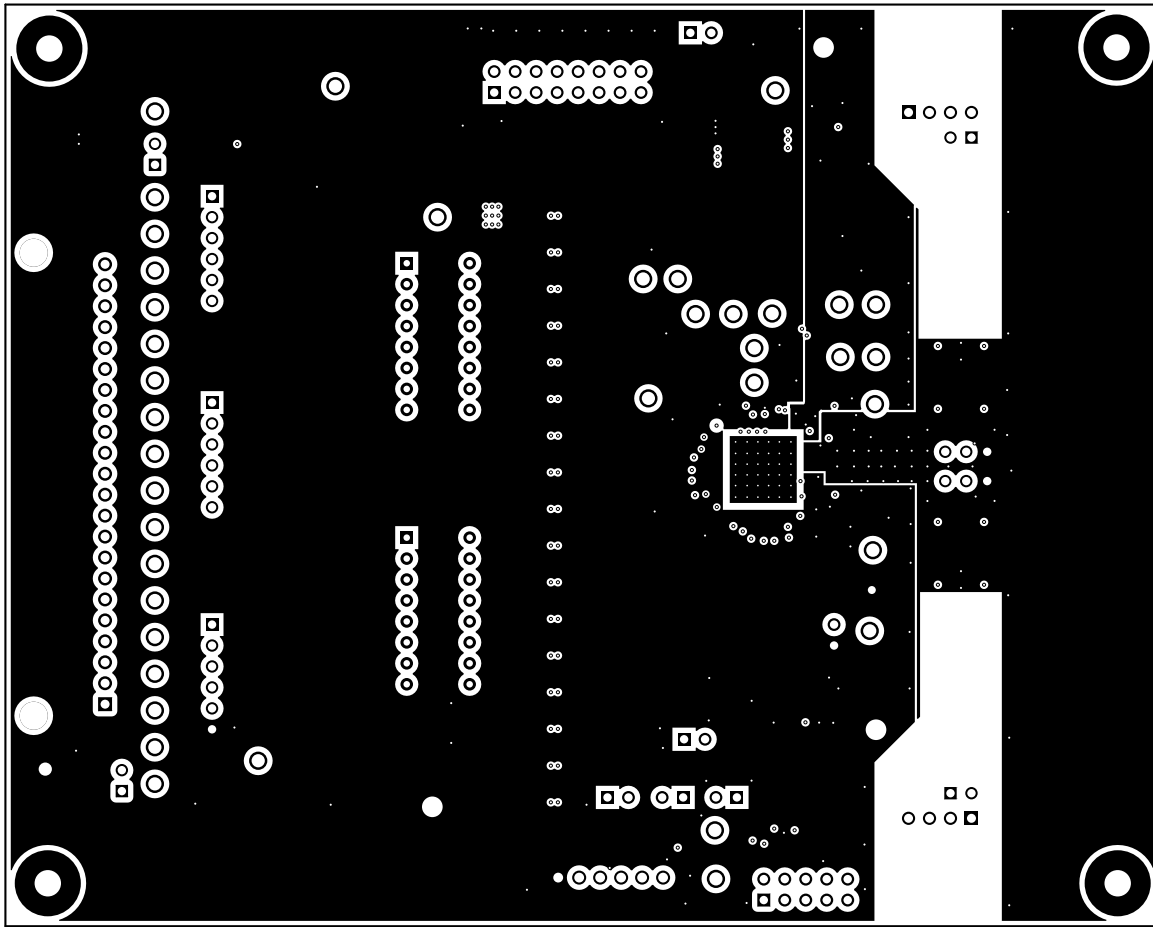

Figure 7-12. BQ79616EVM Internal Signal Layer 1 - GND Plane

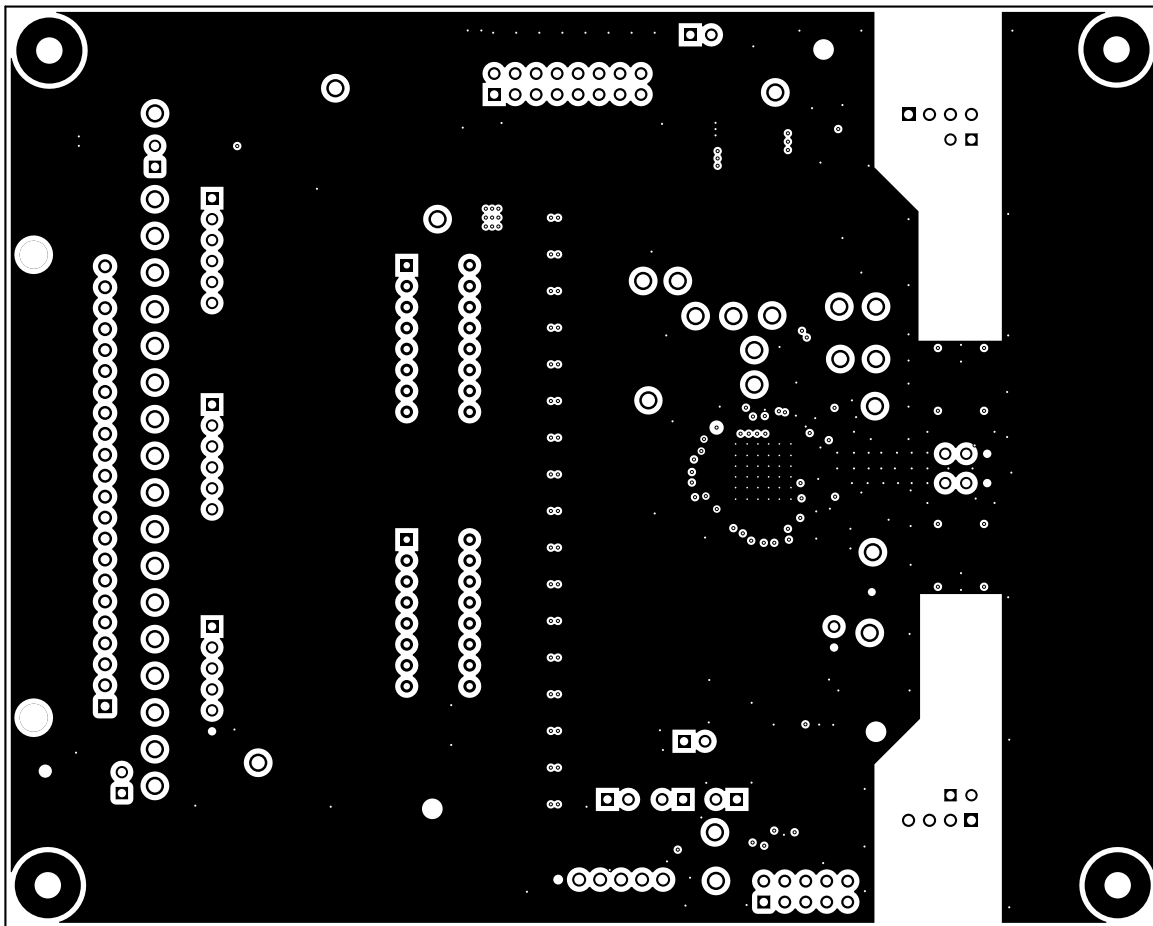

Figure 7-13. BQ79616EVM Internal Signal Layer 2

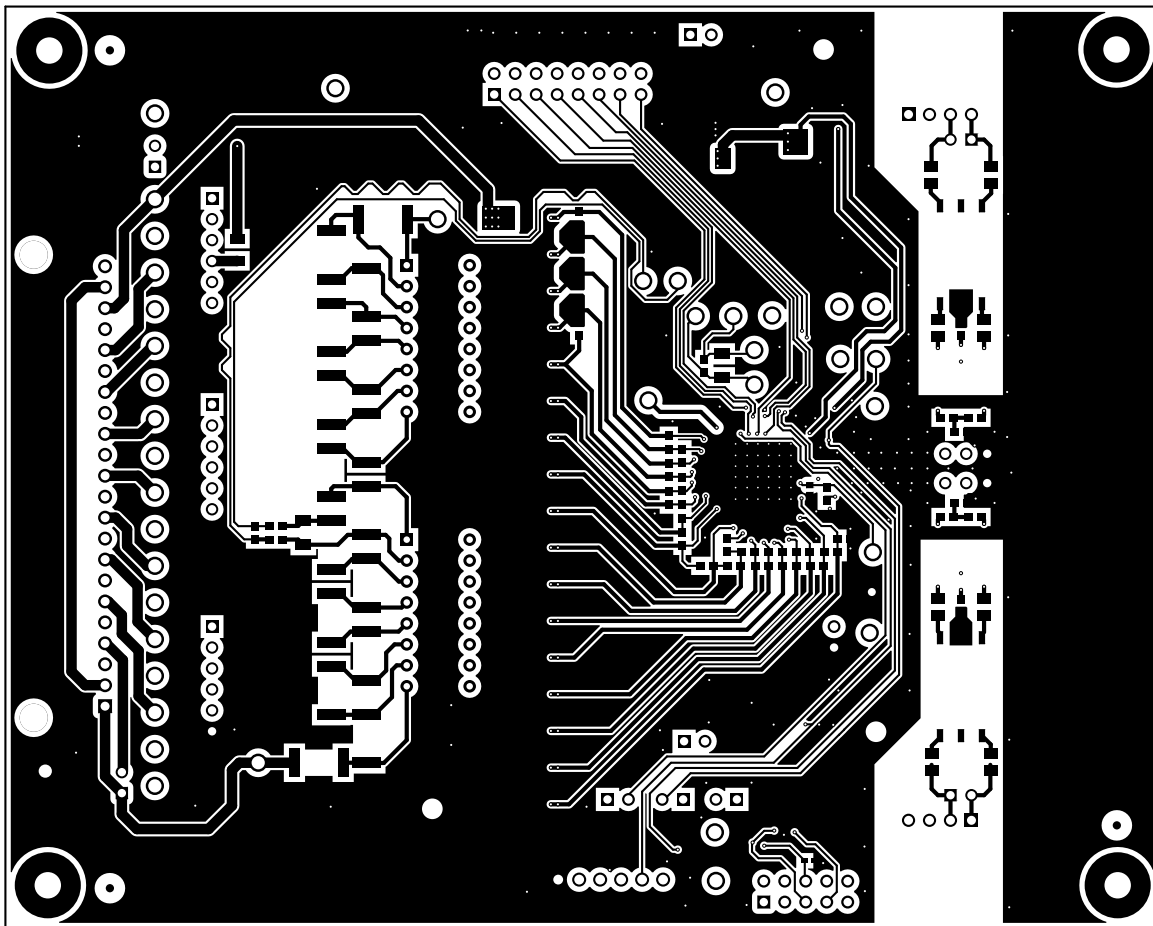

Figure 7-14. BQ79616EVM Bottom Layer

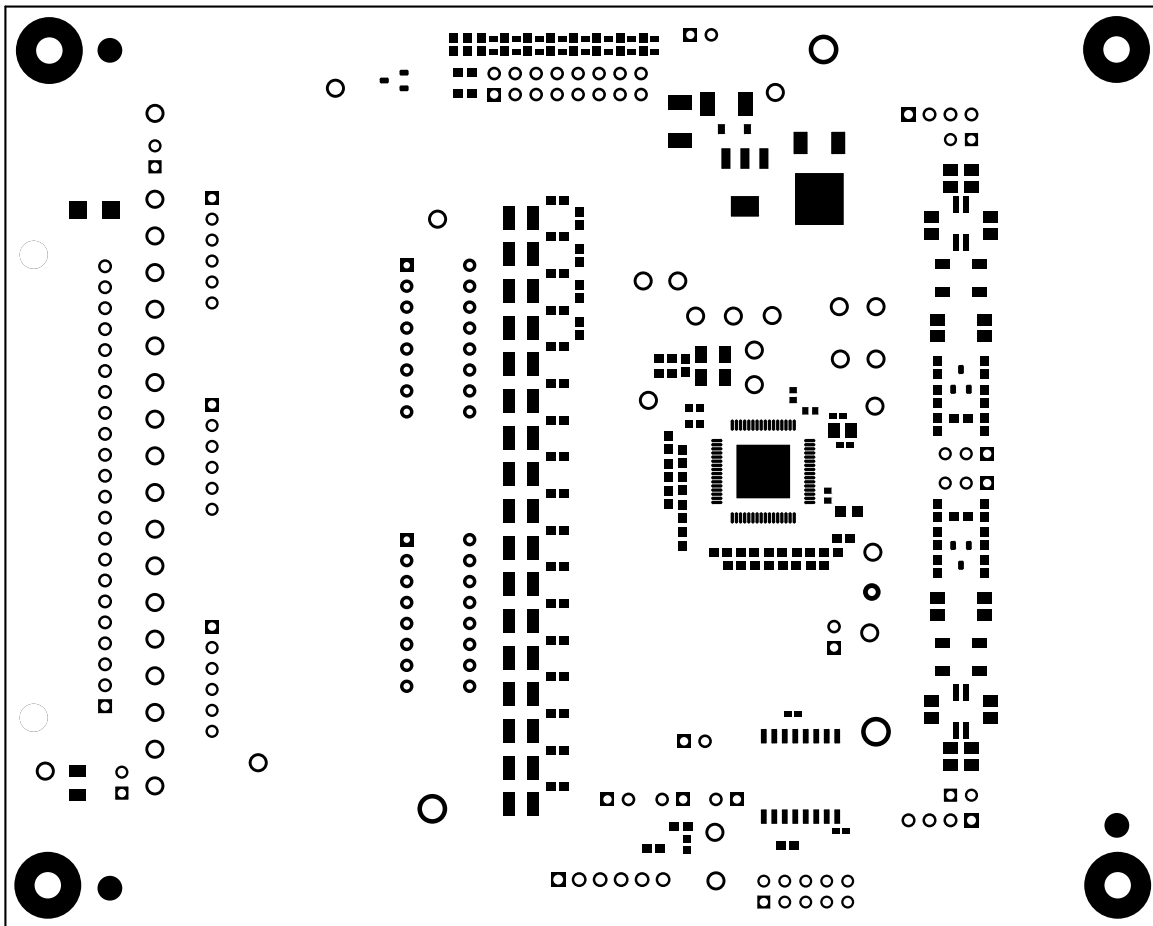

Figure 7-15. BQ79616EVM Bottom Solder

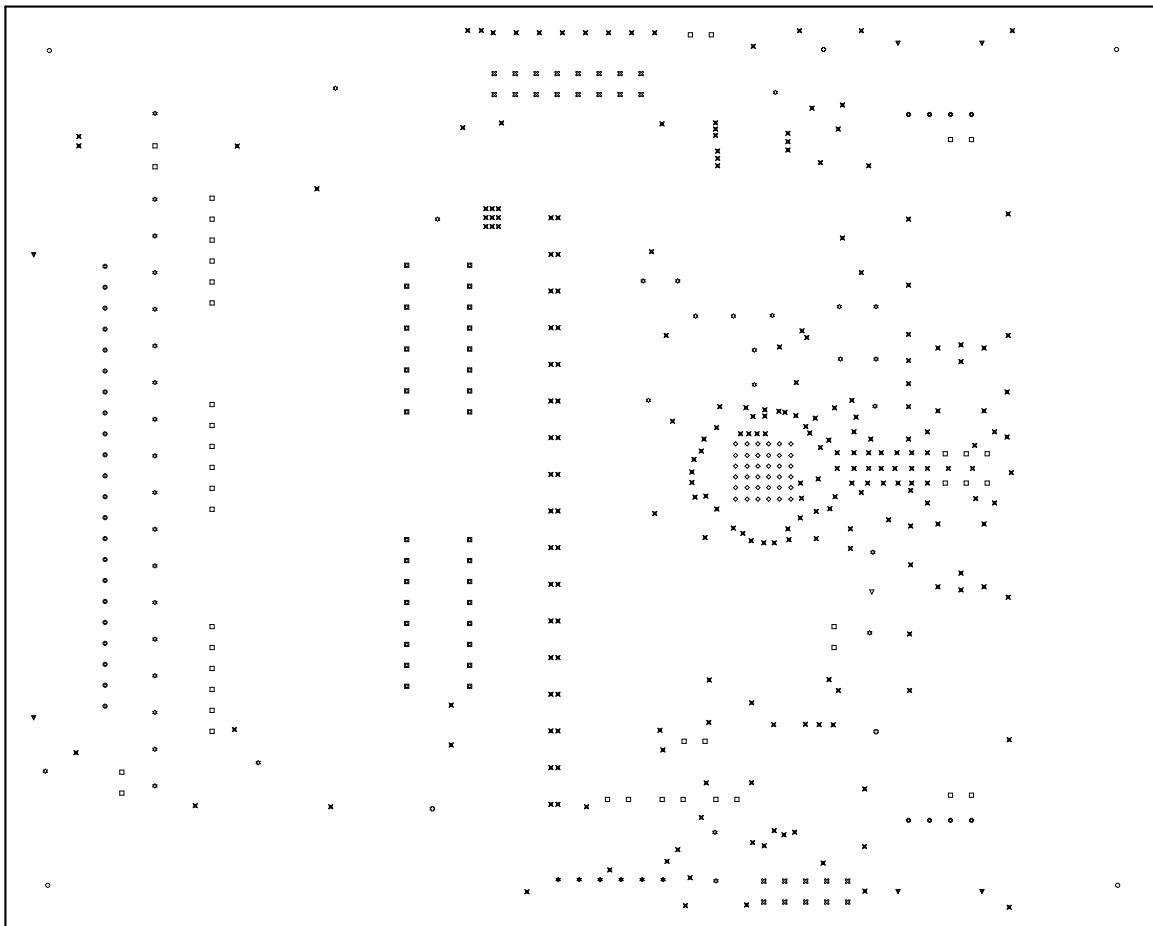

Figure 7-16. BQ79616EVM Drill Drawing

7.4 BQ79616EVM-021 Bill of Materials (BOM)
Table 7-1. BQ79616EVM-021 BOM

Designator	Qty	Value	Description	Package Reference	Part Number	Manufacturer	Alternate	Alternate Manufacturer
!PCB1	1		Printed Circuit Board		BMS021	Any		
C1	1		Multilayer Ceramic Capacitors MLCC - SMD/SMT 1206 0.22uF 100volts X7R +/-10%	1206	GCM31MR72A 224KA37L	Murata		
C2, C6, C8, C9	4		CAP CER 0603 1UF 10 V X7R 10%	0603 (1608 Metric)	C0603C105K8 RACAUTO	KEMET		
C3, C4, C57, C58, C59	5	0.1uF	CAP, CERM, 0.1 uF, 10 V, +/- 10%, X7R, AEC-Q200 Grade 1, 0402	0402	GCM155R71A 104KA55D	MuRata		
C5	1	0.01uF	CAP, CERM, 0.01 uF, 100 V, +/- 10%, X7R, AEC-Q200 Grade 1, 0603	0603	GCM188R72A 103KA37J	MuRata		
C7	1	4.7uF	CAP, CERM, 4.7 uF, 10 V, +/- 20%, X7R, 0805	0805	C2012X7R1A4 75M125AC	TDK		
C10, C23, C24, C25, C26, C27, C28, C29, C30, C31, C32, C33, C34, C35, C36, C37, C38, C39, C40, C41, C42, C43, C44, C45, C46, C47, C48, C49, C50, C51, C52, C53, C54, C55, C56	35	0.47uF	CAP, CERM, 0.47 uF, 16 V, +/- 10%, X7R, AEC-Q200 Grade 1, 0603	0603	GCM188R71C 474KA55D	MuRata		
C13, C14	2	100 pF	CAP, CERM, 100 pF, 50 V, +/- 5%, COG/NP0, AEC-Q200 Grade 1, 0603	0603	GCM1885C1H 101JA16J	MuRata		
C15, C16, C17, C18	4	220 pF	CAP, CERM, 220 pF, 50 V, +/- 5%, X7R, 0603	0603	CL10B221JB8 NNNC	Samsung Electro-Mechanics		
C19, C20, C21, C22	4	2200 pF	CAP, CERM, 2200 pF, 2000 V, +/- 10%, X7R, AEC-Q200 Grade 1, 1206	1206	1206J2K00222 KXR	Knowles Capacitors		
C60	1	1uF	CAP, CERM, 1 uF, 16 V, +/- 10%, X7R, AEC-Q200 Grade 1, 0603	0603	GCM188R71C 105KA64D	MuRata		
D1	1	Green	LED, Green, SMD	LED_0805	LTST-C170KGKT	Lite-On		
D2, D3, D5	3	24 V	Diode, TVS, Bi, 24 V, 70 Vc, AEC-Q101, SOT-23	SOT-23	PESD1CAN,21 5	NXP Semiconductor		
FID1, FID2, FID3, FID4, FID5, FID6	6		Fiducial mark. There is nothing to buy or mount.	N/A	N/A	N/A		
H1, H2, H3, H4	4		Machine Screw, Round, #4-40 x 1/4, Nylon, Philips panhead	Screw	NY PMS 440 0025 PH	B&F Fastener Supply		
H5, H6, H7, H8	4		Standoff, Hex, 0.5"L #4-40 Nylon	Standoff	1902C	Keystone		

Table 7-1. BQ79616EVM-021 BOM (continued)

Designator	Qty	Value	Description	Package Reference	Part Number	Manufacturer	Alternate	Alternate Manufacturer
H9	1		CONN HOUSING 22POS .100 W / LATCH		50-57-9422	Molex		
H11, H12	2		Rectangular Housing Connector, 4 Pos, 2.54mm		50-57-9404	Molex		
J1, J2, J5, J6, J18, J21	6		Header, 2.54mm, 1x2, Tin, Black, TH	Header, 2.54mm, 2x1, TH	PEC01DAAN	Sullins Connector Solutions		
J3	1		Header, 0.5mm, 6x1, R/A, Gold, TH	Header, 0.5mm, 6x1, R/A, TH	22-12-4062	Molex		
J4	1		Header, 2.54 mm, 8x2, Tin, Vertical, TH	Header, 2.54 mm, 8x2, TH	PEC08DAAN	Sullins Connector Solutions		
J7, J8, J9	3		Header, 100mil, 6x1, Tin, TH	TH, 6-Leads, Body 608x100mil, Pitch 100mil	PEC06SAAN	Sullins Connector Solutions		
J10, J11	2		Header(shrouded), 2.54mm, 4x1, R/A, Gold, TH	Header(shrouded), 2.54mm, 4x1, R/A, TH	70551-0038	Molex		
J12, J13, J14, J16	4		Header, 100mil, 2x1, Tin, TH	Header, 2 PIN, 100mil, Tin	PEC02SAAN	Sullins Connector Solutions		
J15	1		Connector Header Through Hole, Right Angle 22 position 0.100" (2.54mm)	HDR22	705550056	Molex		
J17	1		CONN HEADER 10POS .100 DL R/A AU	HDR10	TSW-105-08-L- D-RA	Samtec		
J19, J20	2		Header, 100mil, 3x1, Tin, TH	Header, 3 PIN, 100mil, Tin	PEC03SAAN	Sullins Connector Solutions		
L1, L2	2	470uH	Coupled inductor, 470 uH, 0.4 A, 0.35 ohm, SMD	5x3.3mm	744242471	Würth Elektronik		
LBL1	1		Thermal Transfer Printable Labels, 0.650" W x 0.200" H - 10,000 per roll	PCB Label 0.650 x 0.200 inch	THT-14-423-10	Brady		
Q1	1	150 V	Transistor, NPN, 150 V, 1 A, AEC-Q101, DPAK	DPAK	ZXTN4004KTC	Diodes Inc.		
R2, R120, R123	3	100k	RES, 100 k, 5%, 0.1 W, AEC-Q200 Grade 0, 0603	0603	CRCW060310 0KJNEA	Vishay-Dale		
R3	1	100	RES, 100, 1%, 0.75 W, AEC-Q200 Grade 0, 2010	2010	CRCW201010 0RFKEF	Vishay-Dale		
R4	1	200	RES, 200, 1%, 0.75 W, AEC-Q200 Grade 0, 2010	2010	CRCW201020 0RFKEF	Vishay-Dale		
R5	1	30.0	RES, 30.0, 1%, 0.1 W, AEC-Q200 Grade 0, 0603	0603	ERJ-3EKF30R 0V	Panasonic		
R7, R8, R11, R14, R15, R16, R18, R19	8	10.0k	RES, 10.0 k, 1%, 0.1 W, AEC-Q200 Grade 0, 0603	0603	CRCW060310 K0FKEA	Vishay-Dale		
R9, R12	2	402	RES, 402, 1%, 0.1 W, AEC-Q200 Grade 0, 0603	0603	CRCW060340 2RFKEA	Vishay-Dale		

Table 7-1. BQ79616EVM-021 BOM (continued)

Designator	Qty	Value	Description	Package Reference	Part Number	Manufacturer	Alternate	Alternate Manufacturer
R29, R30, R31, R32, R33, R34, R35, R36, R37, R42, R43, R44, R45, R46, R47, R48	16	100	RES, 100, 1%, 1 W, AEC-Q200 Grade 0, 2512	2512	CRCW2512100RFKEG	Vishay-Dale		
R39	1	0.1	RES, 0.1, 5%, 0.1 W, 0603	0603	CRL0603-JW-R100ELF	Bourns		
R40, R49	2	0	RES, 0, 5%, 0.25 W, AEC-Q200 Grade 0, 1206	1206	ERJ-8GEY0R00V	Panasonic		
R50, R51, R52, R53, R54, R55, R56, R57, R68, R69, R70, R71, R72, R73, R74, R75, R76, R77, R78, R79	20	0	RES, 0, 5%, 0.333 W, AEC-Q200 Grade 0, 0805	0805	CRCW0805000Z0EAHP	Vishay-Dale		
R58, R61, R64, R67	4	0	RES, 0, 5%, 0.1 W, 0603	0603	RC0603JR-070RL	Yageo		
R59, R60, R65, R66	4	51	RES, 51, 5%, 0.1 W, AEC-Q200 Grade 0, 0603	0603	CRCW060351R0JNEA	Vishay-Dale		
R62, R63	2	1.00k	RES, 1.00 k, 1%, 0.1 W, 0603	0603	ERJ-3EKF1001V	Panasonic		
R80, R81, R84, R85, R89, R90, R93, R94, R97, R98, R101, R102, R105, R106, R109, R110, R113	17	100	RES, 100, 0.1%, 0.1 W, AEC-Q200 Grade 0, 0603	0603	ERA-3AEB101V	Panasonic		
R82, R83, R86, R87, R91, R92, R95, R96, R99, R100, R103, R104, R107, R108, R111, R112, R114	17	10.0	RES, 10.0, 1%, 0.75 W, AEC-Q200 Grade 0, 1210	1210	CRCW121010R0FKEAHP	Vishay-Dale		
R88	1	0	RES, 0, 5%, 0.1 W, AEC-Q200 Grade 0, 0603	0603	CRCW0603000Z0EA	Vishay-Dale		
R119	1	100	RES, 100, 5%, 0.25 W, AEC-Q200 Grade 0, 0603	0603	ESR03EZPJ101	Rohm		
R121, R128	2	1.0k	RES, 1.0 k, 5%, 0.1 W, AEC-Q200 Grade 0, 0603	0603	CRCW06031K00JNEA	Vishay-Dale		
RT1, RT2, RT3, RT4, RT5, RT6, RT7, RT8	8	10k	Thermistor NTC, 10k ohm, 2%, 0603	0603	ERT-J1VG103GA	Panasonic		

Table 7-1. BQ79616EVM-021 BOM (continued)

Designator	Qty	Value	Description	Package Reference	Part Number	Manufacturer	Alternate	Alternate Manufacturer
S1, S2	2		Switch, SPST 8Pos, Rocker, TH	9.65X8X22.4 mm	76SB08ST	Grayhill		
SH1, SH2, SH3, SH4, SH5, SH6, SH7, SH8	8		Shunt, 100mil, Gold plated, Black	Shunt 2 pos. 100 mil	881545-2	TE Connectivity		
TP1, TP2, TP3, TP4, TP5, TP6, TP7, TP8, TP9, TP10, TP11, TP12, TP16, TP17, TP18, TP19, TP21, TP22, TP23, TP24, TP25, TP26, TP27, TP28, TP29, TP30, TP31, TP32, TP33, TP34, TP35, TP36, TP42, TP43, TP44	35		Test Point, Multipurpose, White, TH	White Multipurpose Testpoint	5012	Keystone		
TP13, TP14, TP15	3		Terminal, Turret, TH, Triple	Keystone159 8-2	1598-2	Keystone		
TP20, TP38, TP39	3		Test Point, Multipurpose, Black, TH	Black Multipurpose Testpoint	5011	Keystone		
TP37, TP40	2		Test Point, Multipurpose, Red, TH	Red Multipurpose Testpoint	5010	Keystone		
U1	1		SafeTI™ Precision Monitor With Integrated Hardware Protector for Lithium-Ion, Lithium Phosphate, Lithium Titanate Battery Pack, PAP0064F (HTQFP-64)	PAP0064F	BQ79616PAPQ 1	Texas Instruments		Texas Instruments
U2	1		Automotive, Low Power, Quad-Channel 2/2 Digital Isolator, DW0016B (SOIC-16)	DW0016B	ISO7342CQD WRQ1	Texas Instruments	ISO7342CQD WQ1	Texas Instruments
C11	0	0.47uF	CAP, CERM, 0.47 uF, 16 V, +/- 10%, X7R, AEC-Q200 Grade 1, 0603	0603	GCM188R71C 474KA55D	MuRata		
C12	0	1uF	CAP, CERM, 1 uF, 16 V, +/- 10%, X7R, AEC-Q200 Grade 1, 0603	0603	GCM188R71C 105KA64D	MuRata		

Table 7-1. BQ79616EVM-021 BOM (continued)

Designator	Qty	Value	Description	Package Reference	Part Number	Manufacturer	Alternate	Alternate Manufacturer
C61, C62	0	0.01uF	CAP, CERM, 0.01 uF, 50 V, +/- 10%, X7R, 0603	0603	CL10B103KB8 NCNC	Samsung Electro-Mechanics		
D4	0	75 V	Diode, TVS, Uni, 75 V, 121 Vc, 400 W, 3.3 A, SMA	SMA	SMAJ75A	Littelfuse		
Q2	0	80 V	Transistor, NPN, 80 V, 1 A, AEC-Q101, SOT-223	SOT-223	BCP56T1G	ON Semiconductor		
R10, R13, R17, R122	0	0	RES, 0, 5%, 0.25 W, AEC-Q200 Grade 0, 1206	1206	ERJ-8GEY0R00V	Panasonic		
R20	0	100k	RES, 100 k, 5%, 0.1 W, AEC-Q200 Grade 0, 0603	0603	CRCW0603100KJNEA	Vishay-Dale		
R21, R22, R23, R24, R25, R26, R27, R28, R38, R41	0	0	RES, 0, 5%, 0.1 W, AEC-Q200 Grade 0, 0603	0603	CRCW0603000Z0EA	Vishay-Dale		
R115, R116, R117, R118	0	499	RES, 499, 1%, 0.1 W, 0603	0603	RC0603FR-07499RL	Yageo		
T1, T2	0		BMS TRANSFORMER	SMT_TRANSFORMER_8M89_10MM09	HMU1228NL	Pulse		

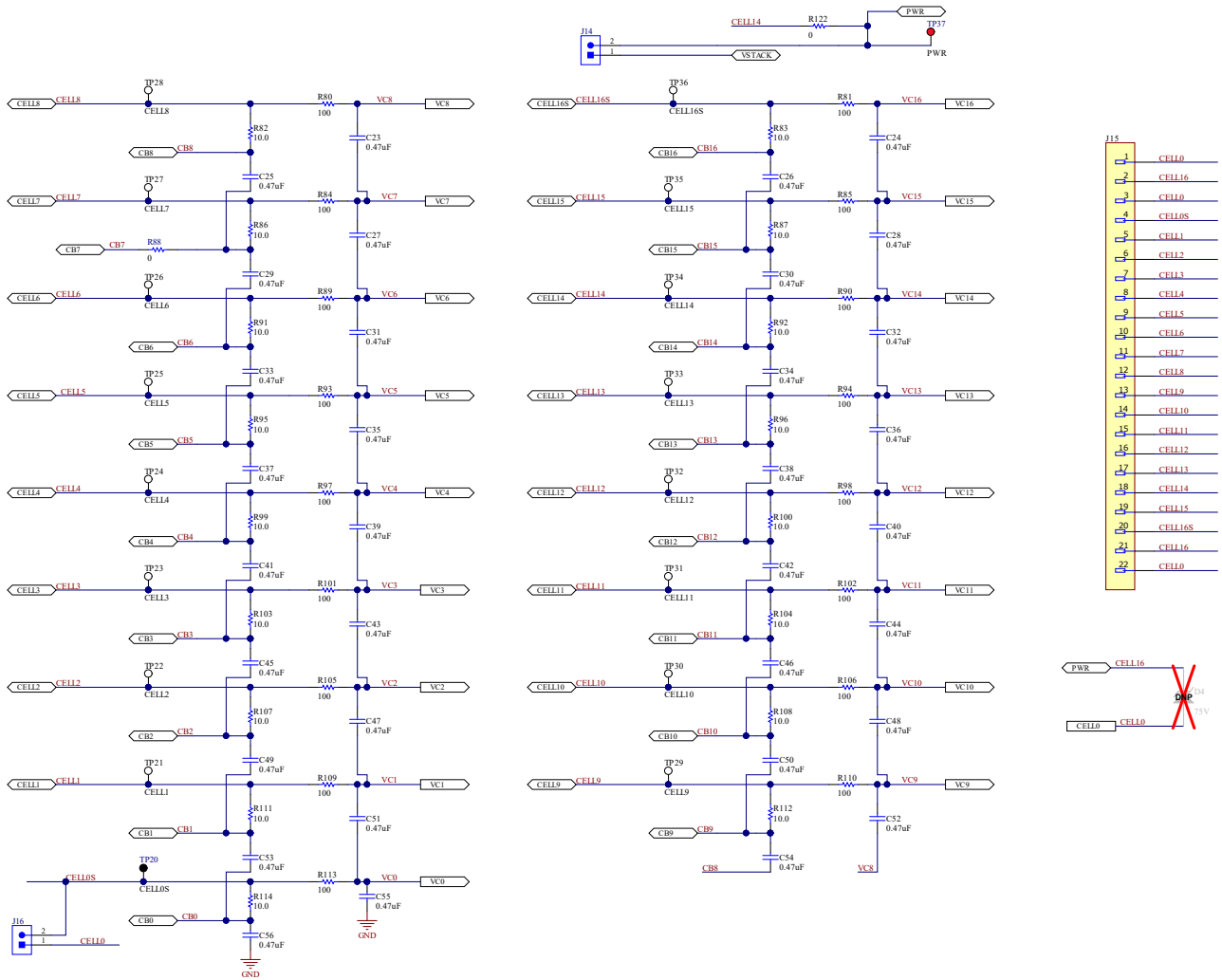

Figure 8-2. BQ75614EVM Schematic Part 2

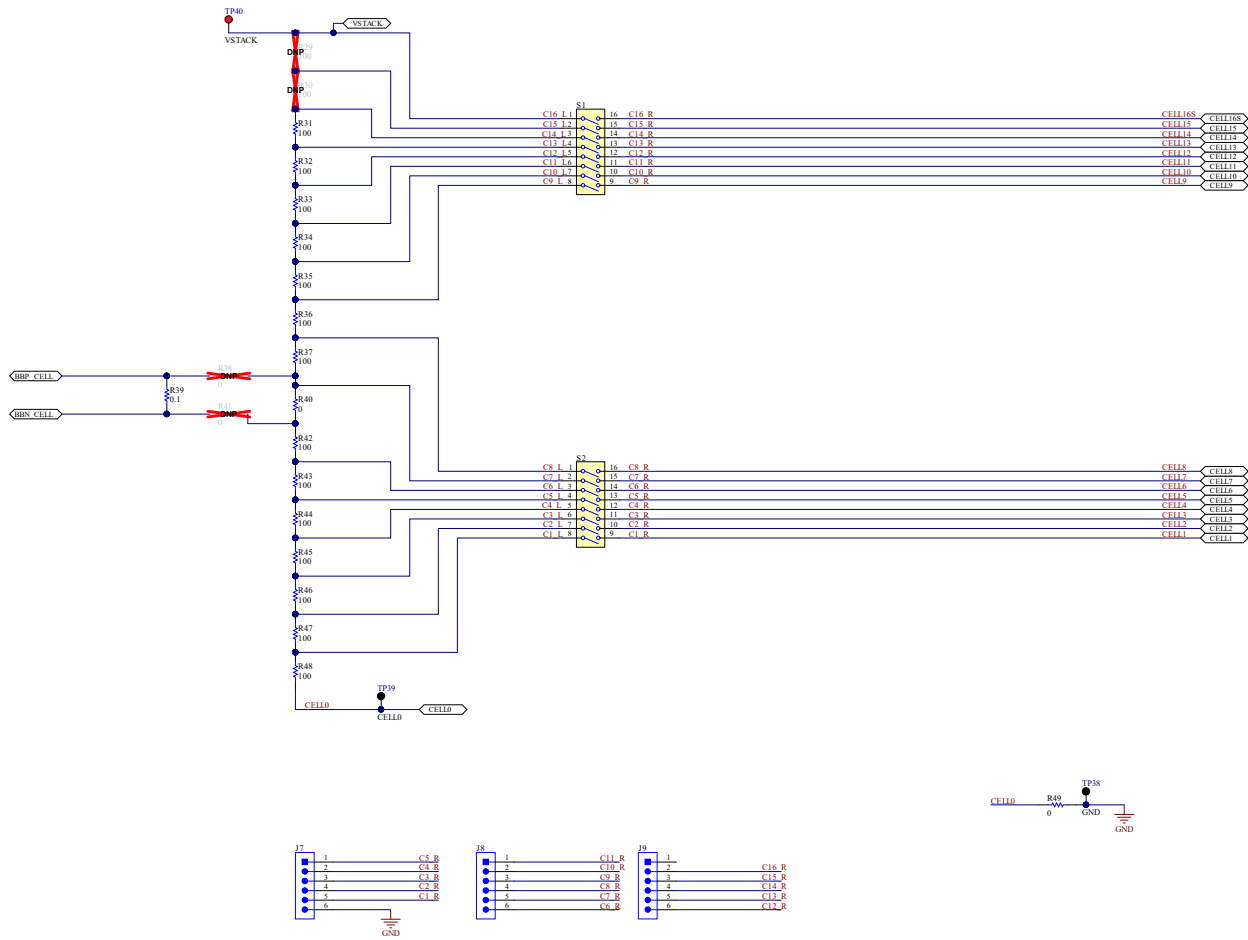

Figure 8-3. BQ75614EVM Schematic Part 3

8.2 Assembly

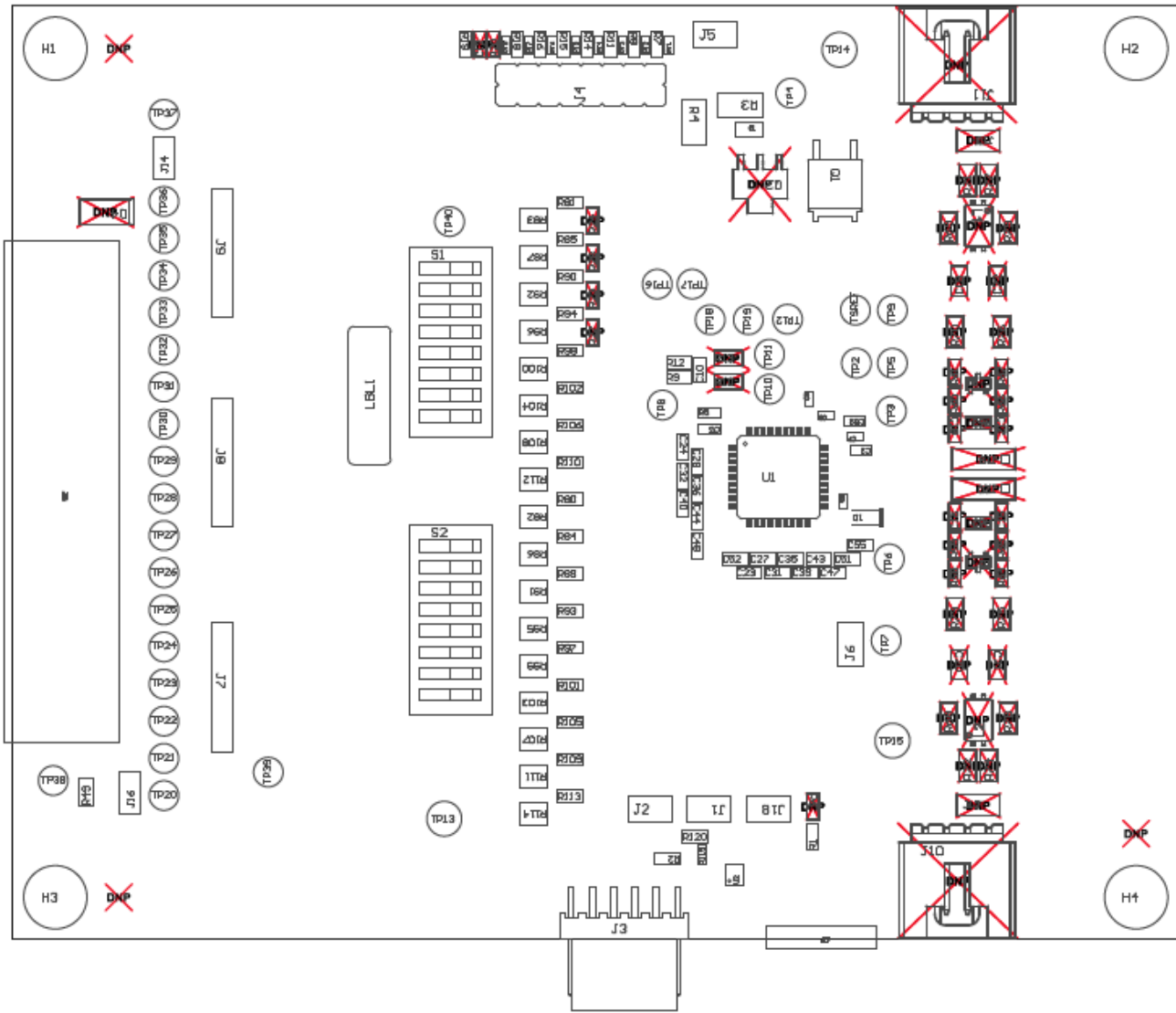

Figure 8-5. BQ75614EVM Assembly Top

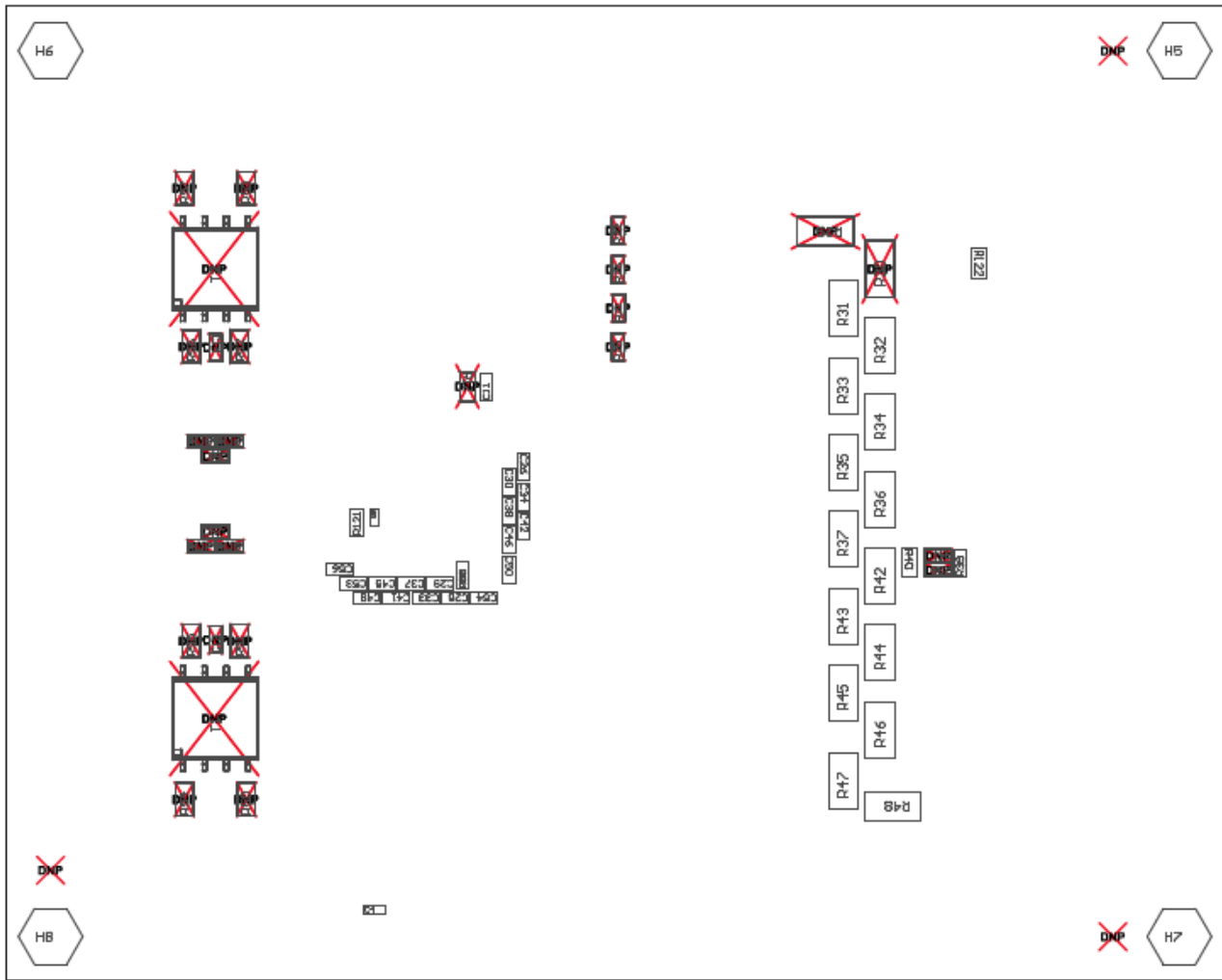

Figure 8-6. BQ75614EVM Assembly Bottom

8.3 Layout

See section 7.3 for same drawings as for BQ79616.

8.4 BQ75614EVM Bill of Materials (BOM)

Table 8-1. BQ75614EVM Bill of Materials

Designator	Qty	Value	Description	Package Reference	Part Number	Manufacturer	Alternate Part Number	Alternate Manufacturer
!PCB1	1		Printed Circuit Board		BMS021	Any		
C1	1		Multilayer Ceramic Capacitors MLCC - SMD/SMT 1206 0.22uF 100volts X7R +/-10%	1206	GCM31MR72A 224KA37L	Murata		
C2, C6, C8, C9	4		CAP CER 0603 1UF 10 V X7R 10%	0603 (1608 Metric)	C0603C105K8 RACAUTO	KEMET		
C3, C4, C57, C58, C59	5	0.1uF	CAP, CERM, 0.1 uF, 10 V, +/- 10%, X7R, AEC-Q200 Grade 1, 0402	0402	GCM155R71A1 04KA55D	MuRata		
C5	1	0.01uF	CAP, CERM, 0.01 uF, 100 V, +/- 10%, X7R, AEC-Q200 Grade 1, 0603	0603	GCM188R72A1 03KA37J	MuRata		
C7	1	4.7uF	CAP, CERM, 4.7 uF, 10 V, +/- 20%, X7R, 0805	0805	C2012X7R1A4 75M125AC	TDK		
C10, C11, C23, C24, C25, C26, C27, C28, C29, C30, C31, C32, C33, C34, C35, C36, C37, C38, C39, C40, C41, C42, C43, C44, C45, C46, C47, C48, C49, C50, C51, C52, C53, C54, C55, C56	36	0.47uF	CAP, CERM, 0.47 uF, 16 V, +/- 10%, X7R, AEC-Q200 Grade 1, 0603	0603	GCM188R71C 474KA55D	MuRata		
C12, C60	2	1uF	CAP, CERM, 1 uF, 16 V, +/- 10%, X7R, AEC-Q200 Grade 1, 0603	0603	GCM188R71C 105KA64D	MuRata		
D1	1	Green	LED, Green, SMD	LED_0805	LTST-C170KGKT	Lite-On		
D3	1	24 V	Diode, TVS, Bi, 24 V, 70 Vc, AEC-Q101, SOT-23	SOT-23	PESD1CAN,21 5	NXP Semiconductor		
FID1, FID2, FID3, FID4, FID5, FID6	6		Fiducial mark. There is nothing to buy or mount.	N/A	N/A	N/A		
H1, H2, H3, H4	4		Machine Screw, Round, #4-40 x 1/4, Nylon, Philips panhead	Screw	NY PMS 440 0025 PH	B&F Fastener Supply		
H5, H6, H7, H8	4		Standoff, Hex, 0.5"L #4-40 Nylon	Standoff	1902C	Keystone		
H9	1		CONN HOUSING 22POS .100 W / LATCH		50-57-9422	Molex		
H11, H12	2		Rectangular Housing Connector, 4 Pos, 2.54mm		50-57-9404	Molex		
J1, J2, J5, J6, J18, J21	6		Header, 2.54mm, 1x2, Tin, Black, TH	Header, 2.54mm, 2x1, TH	PEC01DAAN	Sullins Connector Solutions		

Table 8-1. BQ75614EVM Bill of Materials (continued)

Designator	Qty	Value	Description	Package Reference	Part Number	Manufacturer	Alternate Part Number	Alternate Manufacturer
J3	1		Header, 0.5mm, 6x1, R/A, Gold, TH	Header, 0.5mm, 6x1, R/A, TH	22-12-4062	Molex		
J4	1		Header, 2.54 mm, 8x2, Tin, Vertical, TH	Header, 2.54 mm, 8x2, TH	PEC08DAAN	Sullins Connector Solutions		
J7, J8, J9	3		Header, 100mil, 6x1, Tin, TH	TH, 6-Leads, Body 608x100mil, Pitch 100mil	PEC06SAAN	Sullins Connector Solutions		
J14, J16	2		Header, 100mil, 2x1, Tin, TH	Header, 2 PIN, 100mil, Tin	PEC02SAAN	Sullins Connector Solutions		
J15	1		Connector Header Through Hole, Right Angle 22 position 0.100" (2.54mm)	HDR22	705550056	Molex		
J17	1		CONN HEADER 10POS .100 DL R/A AU	HDR10	TSW-105-08-L-D-RA	Samtec		
LBL1	1		Thermal Transfer Printable Labels, 0.650" W x 0.200" H - 10,000 per roll	PCB Label 0.650 x 0.200 inch	THT-14-423-10	Brady		
Q1	1	150 V	Transistor, NPN, 150 V, 1 A, AEC-Q101, DPAK	DPAK	ZXTN4004KTC	Diodes Inc.		
R2, R120, R123	3	100k	RES, 100 k, 5%, 0.1 W, AEC-Q200 Grade 0, 0603	0603	CRCW0603100 KJNEA	Vishay-Dale		
R3	1	100	RES, 100, 1%, 0.75 W, AEC-Q200 Grade 0, 2010	2010	CRCW2010100 RFKEF	Vishay-Dale		
R4	1	200	RES, 200, 1%, 0.75 W, AEC-Q200 Grade 0, 2010	2010	CRCW2010200 RFKEF	Vishay-Dale		
R5	1	30.0	RES, 30.0, 1%, 0.1 W, AEC-Q200 Grade 0, 0603	0603	ERJ-3EKF30R 0V	Panasonic		
R7, R8, R11, R14, R15, R16, R18, R19	8	10.0k	RES, 10.0 k, 1%, 0.1 W, AEC-Q200 Grade 0, 0603	0603	CRCW060310 K0FKEA	Vishay-Dale		
R9, R12	2	402	RES, 402, 1%, 0.1 W, AEC-Q200 Grade 0, 0603	0603	CRCW0603402 RFKEA	Vishay-Dale		
R31, R32, R33, R34, R35, R36, R37, R42, R43, R44, R45, R46, R47, R48	14	100	RES, 100, 1%, 1 W, AEC-Q200 Grade 0, 2512	2512	CRCW2512100 RFKEG	Vishay-Dale		
R39	1	0.1	RES, 0.1, 5%, 0.1 W, 0603	0603	CRL0603-JW-R100ELF	Bourns		
R40, R49, R122	3	0	RES, 0, 5%, 0.25 W, AEC-Q200 Grade 0, 1206	1206	ERJ-8GEY0R0 0V	Panasonic		

Table 8-1. BQ75614EVM Bill of Materials (continued)

Designator	Qty	Value	Description	Package Reference	Part Number	Manufacturer	Alternate Part Number	Alternate Manufacturer
R80, R81, R84, R85, R89, R90, R93, R94, R97, R98, R101, R102, R105, R106, R109, R110, R113	17	100	RES, 100, 0.1%, 0.1 W, AEC-Q200 Grade 0, 0603	0603	ERA-3AEB101 V	Panasonic		
R82, R83, R86, R87, R91, R92, R95, R96, R99, R100, R103, R104, R107, R108, R111, R112, R114	17	10.0	RES, 10.0, 1%, 0.75 W, AEC-Q200 Grade 0, 1210	1210	CRCW121010 R0FKEAHP	Vishay-Dale		
R88	1	0	RES, 0, 5%, 0.1 W, AEC-Q200 Grade 0, 0603	0603	CRCW0603000 0Z0EA	Vishay-Dale		
R119	1	100	RES, 100, 5%, 0.25 W, AEC-Q200 Grade 0, 0603	0603	ESR03EZPJ10 1	Rohm		
R121, R128	2	1.0k	RES, 1.0 k, 5%, 0.1 W, AEC-Q200 Grade 0, 0603	0603	CRCW06031K 00JNEA	Vishay-Dale		
RT1, RT2, RT3, RT4, RT5, RT6, RT7, RT8	8	10k	Thermistor NTC, 10k ohm, 2%, 0603	0603	ERT-J1VG103GA	Panasonic		
S1, S2	2		Switch, SPST 8Pos, Rocker, TH	9.65X8X22.4 mm	76SB08ST	Grayhill		
SH1, SH2, SH3, SH4, SH5, SH6, SH7, SH8	8		Shunt, 100mil, Gold plated, Black	Shunt 2 pos. 100 mil	881545-2	TE Connectivity		
TP1, TP2, TP3, TP4, TP5, TP6, TP7, TP8, TP9, TP10, TP11, TP12, TP16, TP17, TP18, TP19, TP21, TP22, TP23, TP24, TP25, TP26, TP27, TP28, TP29, TP30, TP31, TP32, TP33, TP34, TP35, TP36, TP42, TP43, TP44	35		Test Point, Multipurpose, White, TH	White Multipurpose Testpoint	5012	Keystone		
TP13, TP14, TP15	3		Terminal, Turret, TH, Triple	Keystone1598 -2	1598-2	Keystone		
TP20, TP38, TP39	3		Test Point, Multipurpose, Black, TH	Black Multipurpose Testpoint	5011	Keystone		
TP37, TP40	2		Test Point, Multipurpose, Red, TH	Red Multipurpose Testpoint	5010	Keystone		

Table 8-1. BQ75614EVM Bill of Materials (continued)

Designator	Qty	Value	Description	Package Reference	Part Number	Manufacturer	Alternate Part Number	Alternate Manufacturer
U1	1		BQ75614-Q1, PAP0064F (HTQFP-64)	PAP0064F	BQ75614PAPR Q1	Texas Instruments		Texas Instruments
U2	1		Automotive, Low Power, Quad-Channel 2/2 Digital Isolator, DW0016B (SOIC-16)	DW0016B	ISO7342CQD WRQ1	Texas Instruments	ISO7342CQ DWQ1	Texas Instruments
C13, C14	0	100 pF	CAP, CERM, 100 pF, 50 V,+/- 5%, C0G/NP0, AEC-Q200 Grade 1, 0603	0603	GCM1885C1H 101JA16J	MuRata		
C15, C16, C17, C18	0	220 pF	CAP, CERM, 220 pF, 50 V,+/- 5%, X7R, 0603	0603	CL10B221JB8 NNNC	Samsung Electro-Mechanics		
C19, C20, C21, C22	0	2200 pF	CAP, CERM, 2200 pF, 2000 V,+/- 10%, X7R, AEC-Q200 Grade 1, 1206	1206	1206J2K00222 KXR	Knowles Capacitors		
C61, C62	0	0.01uF	CAP, CERM, 0.01 uF, 50 V, +/- 10%, X7R, 0603	0603	CL10B103KB8 NCNC	Samsung Electro-Mechanics		
D2, D5	0	24 V	Diode, TVS, Bi, 24 V, 70 Vc, AEC-Q101, SOT-23	SOT-23	PESD1CAN,21 5	NXP Semiconductor		
D4	0	75 V	Diode, TVS, Uni, 75 V, 121 Vc, 400 W, 3.3 A, SMA	SMA	SMAJ75A	Littelfuse		
J10, J11	0		Header(shrouded), 2.54mm, 4x1, R/A, Gold, TH	Header(shrouded), 2.54mm, 4x1, R/A, TH	70551-0038	Molex		
J12, J13	0		Header, 100mil, 2x1, Tin, TH	Header, 2 PIN, 100mil, Tin	PEC02SAAN	Sullins Connector Solutions		
J19, J20	0		Header, 100mil, 3x1, Tin, TH	Header, 3 PIN, 100mil, Tin	PEC03SAAN	Sullins Connector Solutions		
L1, L2	0	470uH	Coupled inductor, 470 uH, 0.4 A, 0.35 ohm, SMD	5x3.3mm	744242471	Würth Elektronik		
Q2	0	80 V	Transistor, NPN, 80 V, 1 A, AEC-Q101, SOT-223	SOT-223	BCP56T1G	ON Semiconductor		
R10, R13, R17	0	0	RES, 0, 5%, 0.25 W, AEC-Q200 Grade 0, 1206	1206	ERJ-8GEY0R0 0V	Panasonic		
R20	0	100k	RES, 100 k, 5%, 0.1 W, AEC-Q200 Grade 0, 0603	0603	CRCW0603100 KJNEA	Vishay-Dale		
R21, R22, R23, R24, R25, R26, R27, R28, R38, R41	0	0	RES, 0, 5%, 0.1 W, AEC-Q200 Grade 0, 0603	0603	CRCW0603000 0Z0EA	Vishay-Dale		
R29, R30	0	100	RES, 100, 1%, 1 W, AEC-Q200 Grade 0, 2512	2512	CRCW2512100 RFKEG	Vishay-Dale		

Table 8-1. BQ75614EVM Bill of Materials (continued)

Designator	Qty	Value	Description	Package Reference	Part Number	Manufacturer	Alternate Part Number	Alternate Manufacturer
R50, R51, R52, R53, R54, R55, R56, R57, R68, R69, R70, R71, R72, R73, R74, R75, R76, R77, R78, R79	0	0	RES, 0, 5%, 0.333 W, AEC-Q200 Grade 0, 0805	0805	CRCW08050000Z0EAHP	Vishay-Dale		
R58, R61, R64, R67	0	0	RES, 0, 5%, 0.1 W, 0603	0603	RC0603JR-070RL	Yageo		
R59, R60, R65, R66	0	51	RES, 51, 5%, 0.1 W, AEC-Q200 Grade 0, 0603	0603	CRCW060351R0JNEA	Vishay-Dale		
R62, R63	0	1.00k	RES, 1.00 k, 1%, 0.1 W, 0603	0603	ERJ-3EKF1001V	Panasonic		
R115, R116, R117, R118	0	499	RES, 499, 1%, 0.1 W, 0603	0603	RC0603FR-07499RL	Yageo		
T1, T2	0		BMS TRANSFORMER	SMT_TRANSFORMER_8M89_10MM09	HMU1228NL	Pulse		

9 BQ79656EVM Schematic, Assembly, Layout, and BOM

Provided are the BQ79656EVM schematic, assembly, and BOM in their respective sections.

9.1 Schematic

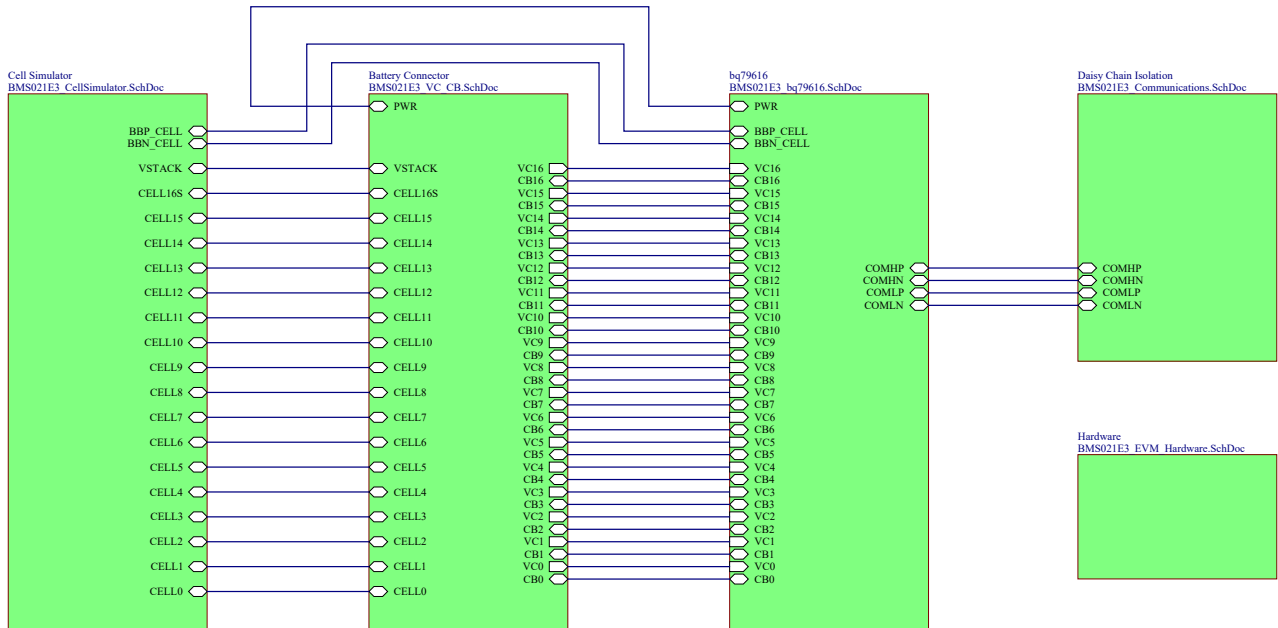
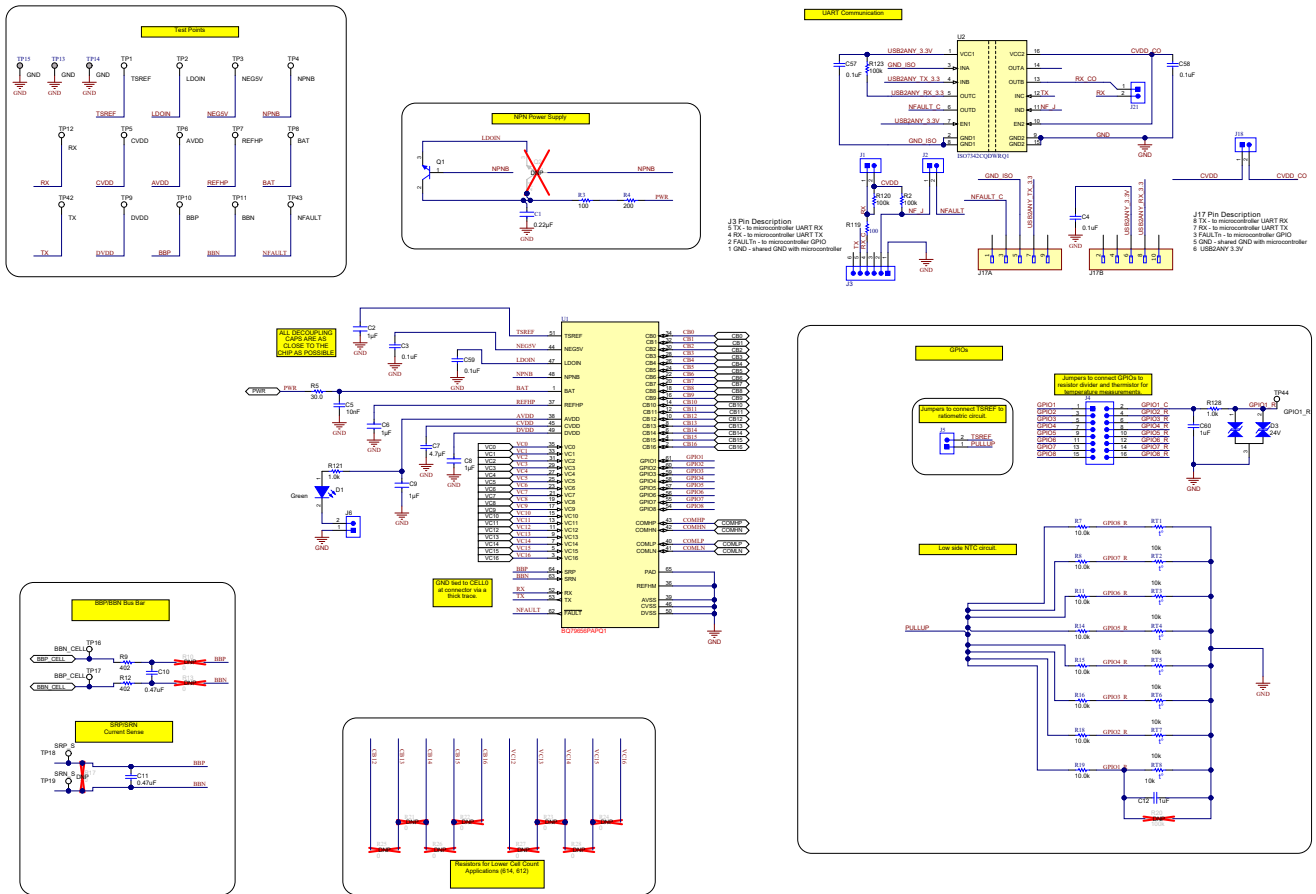

Figure 9-1. BQ79656EVM Schematic Block Diagram



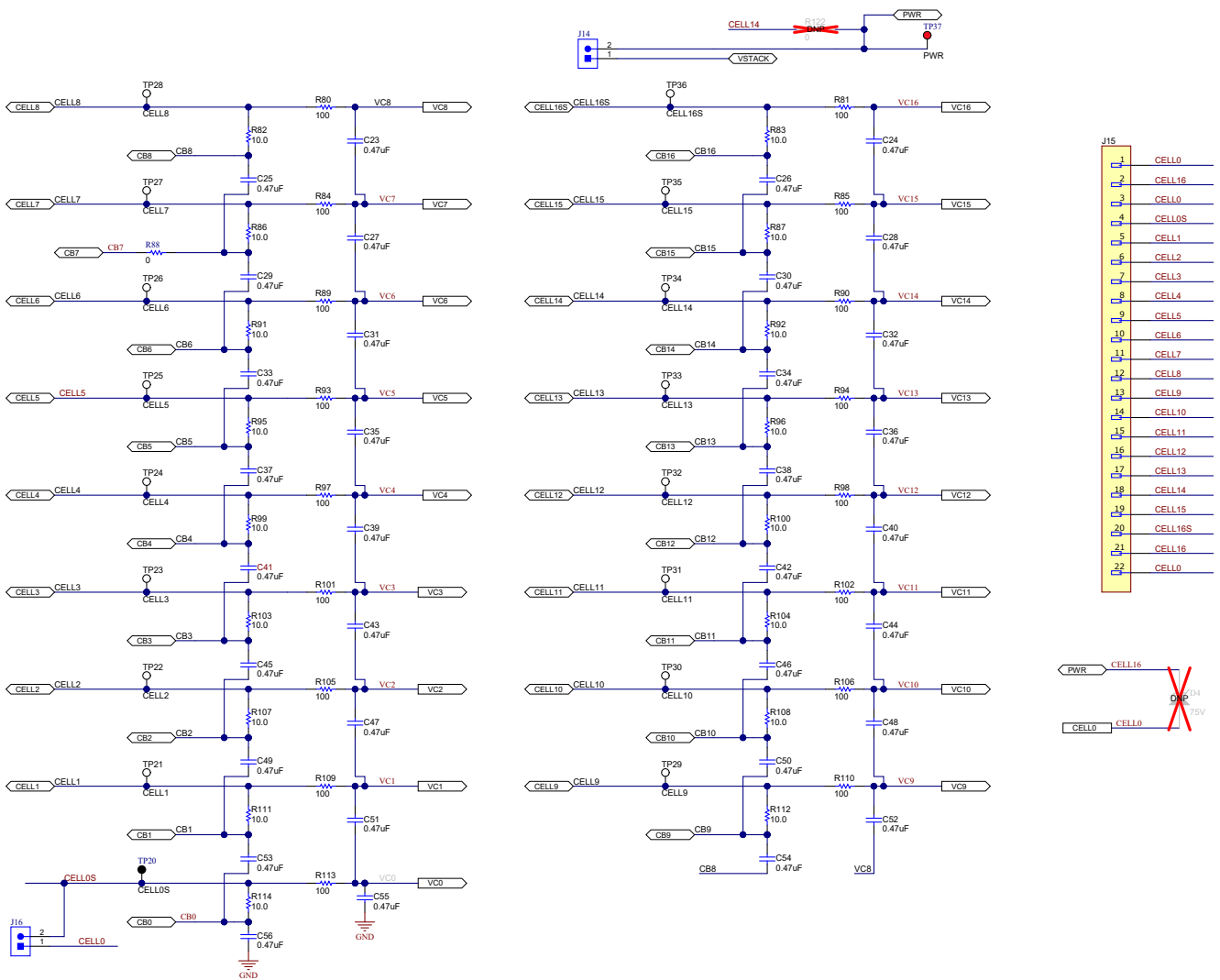

Figure 9-3. BQ79656EVM Schematic Part 2

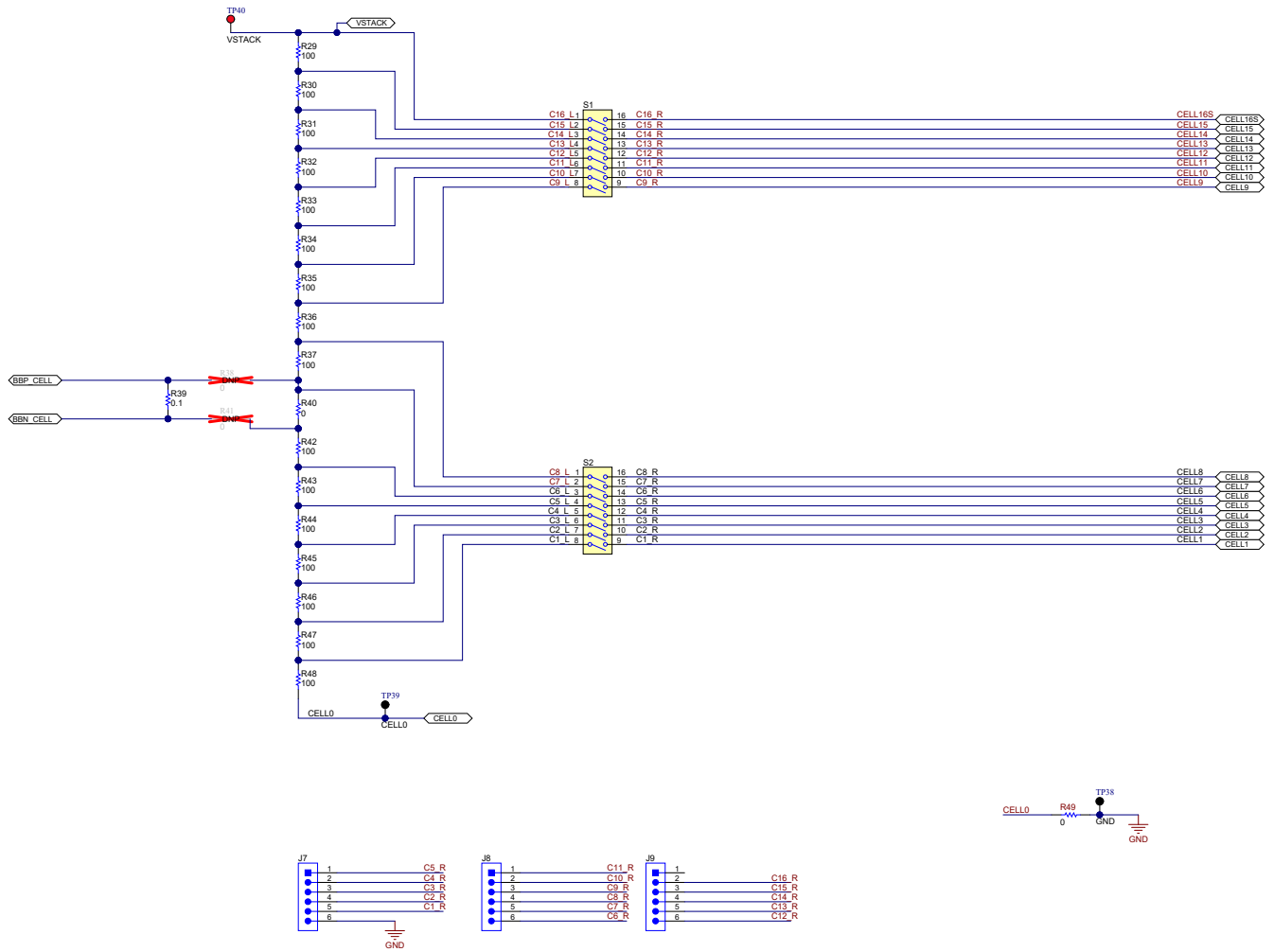

Figure 9-4. BQ79656EVM Schematic Part 3

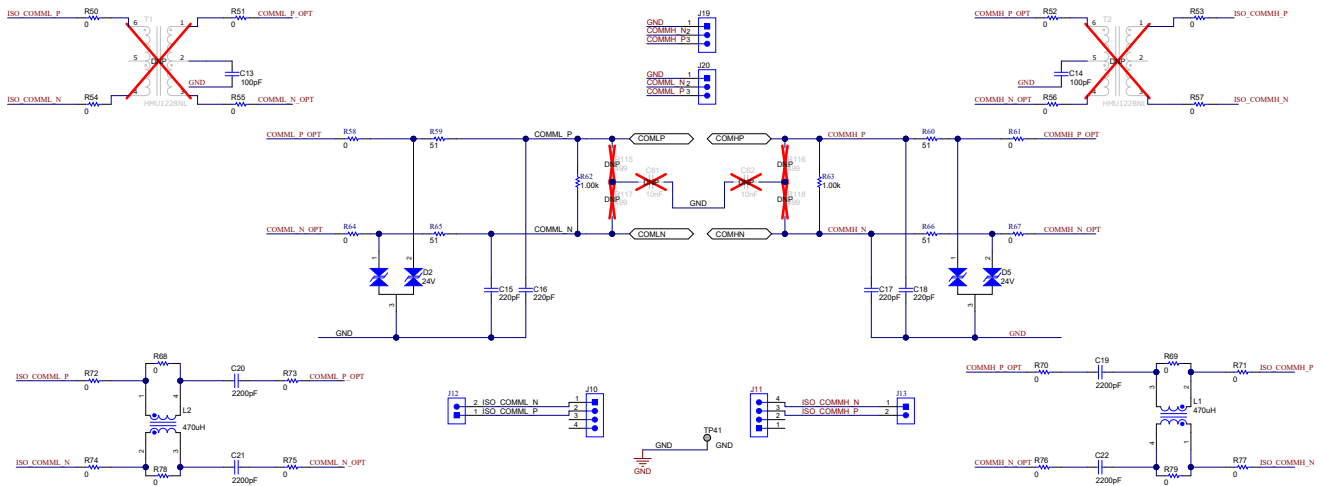
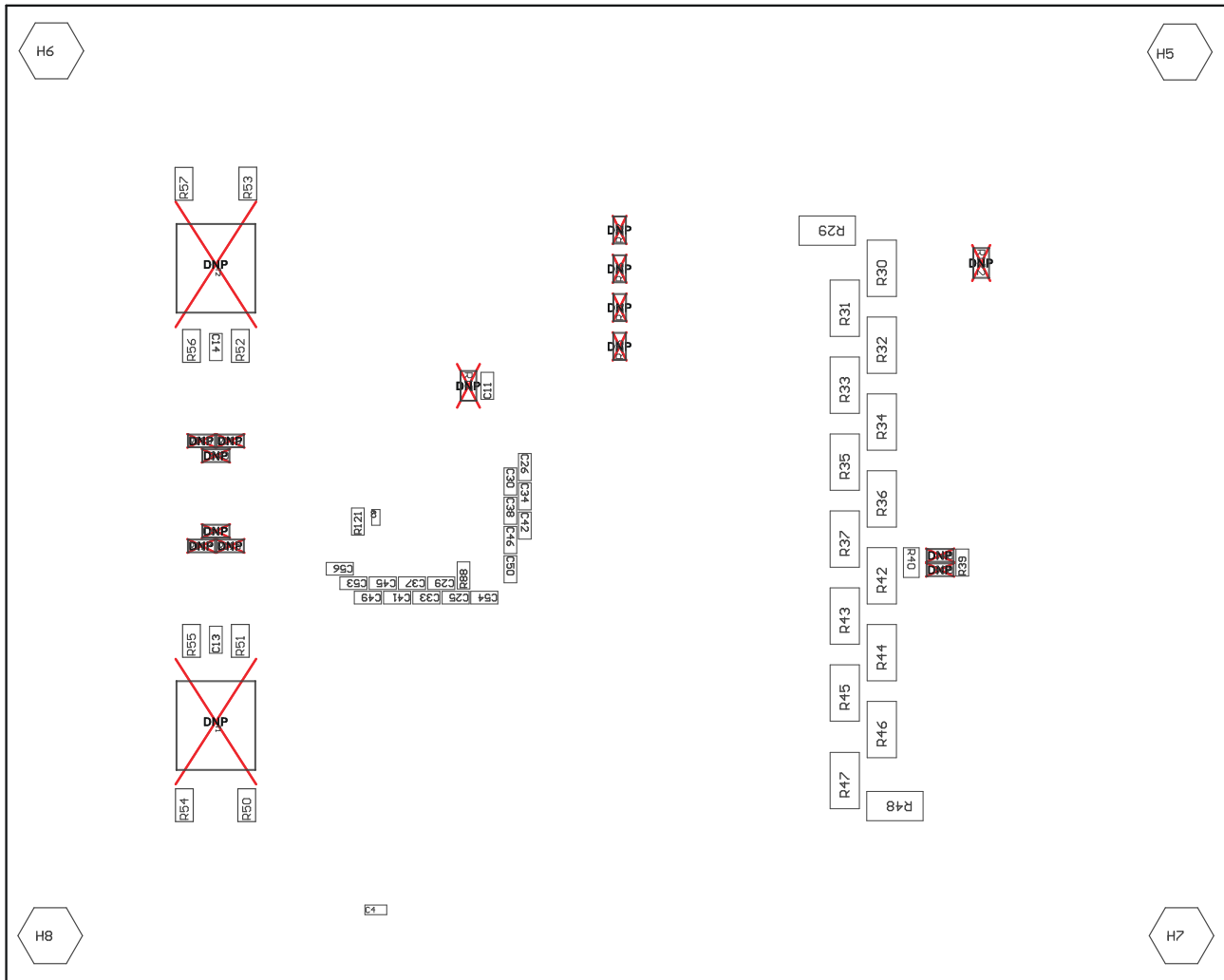

Figure 9-5. BQ79656EVM Schematic Part 4



Components marked 'DNP' must not be populated.

Figure 9-7. BQ79656EVM Assembly Bottom

9.3 Layout

See section 7.3 for same drawings as for BQ79616.

9.4 BQ79656EVM Bill of Materials (BOM)

Table 9-1. BQ79656EVM BOM

Designator	Qty	Value	Description	Package Reference	Part Number	Manufacturer	Alternate Part Number ⁽¹⁾	Alternate Manufacturer
!PCB1	1		Printed Circuit Board		BMS021	Any		
C1	1		Multilayer Ceramic Capacitors MLCC - SMD/SMT 1206 0.22uF 100volts X7R +/-10%	1206	GCM31MR7 2A224KA37L	Murata		
C2, C6, C8, C9	4		CAP CER 0603 1UF 10 V X7R 10%	0603 (1608 Metric)	C0603C105K 8RACAUTO	KEMET		
C3, C4, C57, C58, C59	5	0.1uF	CAP, CERM, 0.1 uF, 10 V, +/- 10%, X7R, AEC-Q200 Grade 1, 0402	0402	GCM155R71 A104KA55D	MuRata		
C5	1	0.01uF	CAP, CERM, 0.01 uF, 100 V,+/- 10%, X7R, AEC-Q200 Grade 1, 0603	0603	GCM188R72 A103KA37J	MuRata		
C7	1	4.7uF	CAP, CERM, 4.7 uF, 10 V, +/- 20%, X7R, 0805	0805	C2012X7R1 A475M125A C	TDK		
C10, C11, C23, C24, C25, C26, C27, C28, C29, C30, C31, C32, C33, C34, C35, C36, C37, C38, C39, C40, C41, C42, C43, C44, C45, C46, C47, C48, C49, C50, C51, C52, C53, C54, C55, C56	36	0.47uF	CAP, CERM, 0.47 uF, 16 V, +/- 10%, X7R, AEC-Q200 Grade 1, 0603	0603	GCM188R71 C474KA55D	MuRata		
C12, C60	2	1uF	CAP, CERM, 1 uF, 16 V, +/- 10%, X7R, AEC-Q200 Grade 1, 0603	0603	GCM188R71 C105KA64D	MuRata		
C13, C14	2	100 pF	CAP, CERM, 100 pF, 50 V,+/- 5%, C0G/NP0, AEC-Q200 Grade 1, 0603	0603	GCM1885C1 H101JA16J	MuRata		
C15, C16, C17, C18	4	220 pF	CAP, CERM, 220 pF, 50 V,+/- 5%, X7R, 0603	0603	CL10B221JB 8NNNC	Samsung Electro-Mechanics		
C19, C20, C21, C22	4	2200 pF	CAP, CERM, 2200 pF, 2000 V,+/- 10%, X7R, AEC-Q200 Grade 1, 1206	1206	1206J2K002 22KXR	Knowles Capacitors		
D1	1	Green	LED, Green, SMD	LED_0805	LTST-C170KGKT	Lite-On		
D2, D3, D5	3	24 V	Diode, TVS, Bi, 24 V, 70 Vc, AEC-Q101, SOT-23	SOT-23	PESD1CAN, 215	NXP Semiconductor		
FID1, FID2, FID3, FID4, FID5, FID6	6		Fiducial mark. There is nothing to buy or mount.	N/A	N/A	N/A		
H1, H2, H3, H4	4		Machine Screw, Round, #4-40 x 1/4, Nylon, Philips panhead	Screw	NY PMS 440 0025 PH	B&F Fastener Supply		

Table 9-1. BQ79656EVM BOM (continued)

Designator	Qty	Value	Description	Package Reference	Part Number	Manufacturer	Alternate Part Number ⁽¹⁾	Alternate Manufacturer
H5, H6, H7, H8	4		Standoff, Hex, 0.5"L #4-40 Nylon	Standoff	1902C	Keystone		
H9	1		CONN HOUSING 22POS .100 W / LATCH		50-57-9422	Molex		
H11, H12	2		Rectangular Housing Connector, 4 Pos, 2.54mm		50-57-9404	Molex		
J1, J2, J5, J6, J18, J21	6		Header, 2.54mm, 1x2, Tin, Black, TH	Header, 2.54mm, 2x1, TH	PEC01DAAN	Sullins Connector Solutions		
J3	1		Header, 0.5mm, 6x1, R/A, Gold, TH	Header, 0.5mm, 6x1, R/A, TH	22-12-4062	Molex		
J4	1		Header, 2.54 mm, 8x2, Tin, Vertical, TH	Header, 2.54 mm, 8x2, TH	PEC08DAAN	Sullins Connector Solutions		
J7, J8, J9	3		Header, 100mil, 6x1, Tin, TH	TH, 6-Leads, Body 608x100mil, Pitch 100mil	PEC06SAAN	Sullins Connector Solutions		
J10, J11	2		Header(shrouded), 2.54mm, 4x1, R/A, Gold, TH	Header(shrouded), 2.54mm, 4x1, R/A, TH	70551-0038	Molex		
J12, J13, J14, J16	4		Header, 100mil, 2x1, Tin, TH	Header, 2 PIN, 100mil, Tin	PEC02SAAN	Sullins Connector Solutions		
J15	1		Connector Header Through Hole, Right Angle 22 position 0.100" (2.54mm)	HDR22	705550056	Molex		
J17	1		CONN HEADER 10POS .100 DL R/A AU	HDR10	TSW-105-08-L-D-RA	Samtec		
J19, J20	2		Header, 100mil, 3x1, Tin, TH	Header, 3 PIN, 100mil, Tin	PEC03SAAN	Sullins Connector Solutions		
L1, L2	2	470uH	Coupled inductor, 470 uH, 0.4 A, 0.35 ohm, SMD	5x3.3mm	744242471	Wurth Elektronik		
LBL1	1		Thermal Transfer Printable Labels, 0.650" W x 0.200" H - 10,000 per roll	PCB Label 0.650 x 0.200 inch	THT-14-423-10	Brady		
Q1	1	150 V	Transistor, NPN, 150 V, 1 A, AEC-Q101, DPAK	DPAK	ZXTN4004K TC	Diodes Inc.		
R2, R120, R123	3	100k	RES, 100 k, 5%, 0.1 W, AEC-Q200 Grade 0, 0603	0603	CRCW0603100KJNEA	Vishay-Dale		
R3	1	100	RES, 100, 1%, 0.75 W, AEC-Q200 Grade 0, 2010	2010	CRCW2010100RFKEF	Vishay-Dale		
R4	1	200	RES, 200, 1%, 0.75 W, AEC-Q200 Grade 0, 2010	2010	CRCW2010200RFKEF	Vishay-Dale		
R5	1	30.0	RES, 30.0, 1%, 0.1 W, AEC-Q200 Grade 0, 0603	0603	ERJ-3EKF30R0V	Panasonic		
R7, R8, R11, R14, R15, R16, R18, R19	8	10.0k	RES, 10.0 k, 1%, 0.1 W, AEC-Q200 Grade 0, 0603	0603	CRCW060310K0FKEA	Vishay-Dale		
R9, R12	2	402	RES, 402, 1%, 0.1 W, AEC-Q200 Grade 0, 0603	0603	CRCW0603402RFKEA	Vishay-Dale		

Table 9-1. BQ79656EVM BOM (continued)

Designator	Qty	Value	Description	Package Reference	Part Number	Manufacturer	Alternate Part Number ⁽¹⁾	Alternate Manufacturer
R29, R30, R31, R32, R33, R34, R35, R36, R37, R42, R43, R44, R45, R46, R47, R48	16	100	RES, 100, 1%, 1 W, AEC-Q200 Grade 0, 2512	2512	CRCW2512100RFKEG	Vishay-Dale		
R39	1	0.1	RES, 0.1, 5%, 0.1 W, 0603	0603	CRL0603-JW-R100ELF	Bourns		
R40, R49	2	0	RES, 0, 5%, 0.25 W, AEC-Q200 Grade 0, 1206	1206	ERJ-8GEY0R00V	Panasonic		
R50, R51, R52, R53, R54, R55, R56, R57, R68, R69, R70, R71, R72, R73, R74, R75, R76, R77, R78, R79	20	0	RES, 0, 5%, 0.333 W, AEC-Q200 Grade 0, 0805	0805	CRCW0805000Z0EAHP	Vishay-Dale		
R58, R61, R64, R67	4	0	RES, 0, 5%, 0.1 W, 0603	0603	RC0603JR-070RL	Yageo		
R59, R60, R65, R66	4	51	RES, 51, 5%, 0.1 W, AEC-Q200 Grade 0, 0603	0603	CRCW060351R0JNEA	Vishay-Dale		
R62, R63	2	1.00k	RES, 1.00 k, 1%, 0.1 W, 0603	0603	ERJ-3EKF1001V	Panasonic		
R80, R81, R84, R85, R89, R90, R93, R94, R97, R98, R101, R102, R105, R106, R109, R110, R113	17	100	RES, 100, 0.1%, 0.1 W, AEC-Q200 Grade 0, 0603	0603	ERA-3AEB101V	Panasonic		
R82, R83, R86, R87, R91, R92, R95, R96, R99, R100, R103, R104, R107, R108, R111, R112, R114	17	10.0	RES, 10.0, 1%, 0.75 W, AEC-Q200 Grade 0, 1210	1210	CRCW121010R0FKEAHP	Vishay-Dale		
R88	1	0	RES, 0, 5%, 0.1 W, AEC-Q200 Grade 0, 0603	0603	CRCW0603000Z0EA	Vishay-Dale		
R119	1	100	RES, 100, 5%, 0.25 W, AEC-Q200 Grade 0, 0603	0603	ESR03EZPJ101	Rohm		
R121, R128	2	1.0k	RES, 1.0 k, 5%, 0.1 W, AEC-Q200 Grade 0, 0603	0603	CRCW06031K00JNEA	Vishay-Dale		
RT1, RT2, RT3, RT4, RT5, RT6, RT7, RT8	8	10k	Thermistor NTC, 10k ohm, 2%, 0603	0603	ERT-J1VG103GA	Panasonic		
S1, S2	2		Switch, SPST 8Pos, Rocker, TH	9.65X8X22.4 mm	76SB08ST	Grayhill		

Table 9-1. BQ79656EVM BOM (continued)

Designator	Qty	Value	Description	Package Reference	Part Number	Manufacturer	Alternate Part Number ⁽¹⁾	Alternate Manufacturer
SH1, SH2, SH3, SH4, SH5, SH6, SH7, SH8	8		Shunt, 100mil, Gold plated, Black	Shunt 2 pos. 100 mil	881545-2	TE Connectivity		
TP1, TP2, TP3, TP4, TP5, TP6, TP7, TP8, TP9, TP10, TP11, TP12, TP16, TP17, TP18, TP19, TP21, TP22, TP23, TP24, TP25, TP26, TP27, TP28, TP29, TP30, TP31, TP32, TP33, TP34, TP35, TP36, TP42, TP43, TP44	35		Test Point, Multipurpose, White, TH	White Multipurpose Testpoint	5012	Keystone		
TP13, TP14, TP15	3		Terminal, Turret, TH, Triple	Keystone159 8-2	1598-2	Keystone		
TP20, TP38, TP39	3		Test Point, Multipurpose, Black, TH	Black Multipurpose Testpoint	5011	Keystone		
TP37, TP40	2		Test Point, Multipurpose, Red, TH	Red Multipurpose Testpoint	5010	Keystone		
U1	1		14S or 16S Standalone Precision Automotive Battery Monitor, Balancer and Integrated Current Sense with up to SafeTITM-26262 ASIL-D ASIL-D Compliance	HTQPF64	BQ79656PA PQ1	Texas Instruments		
U2	1		Automotive, Low-power, Quad-Channel 2/2 Digital Isolator, DW0016B (SOIC-16)	DW0016B	ISO7342CQ DWRQ1	Texas Instruments	ISO7342CQD WQ1	Texas Instruments
C61, C62	0	0.01uF	CAP, CERM, 0.01 uF, 50 V, +/- 10%, X7R, 0603	0603	CL10B103KB 8NCNC	Samsung Electro-Mechanics		
D4	0	75 V	Diode, TVS, Uni, 75 V, 121 Vc, 400 W, 3.3 A, SMA	SMA	SMAJ75A	Littelfuse		
Q2	0	80 V	Transistor, NPN, 80 V, 1 A, AEC-Q101, SOT-223	SOT-223	BCP56T1G	ON Semiconductor		
R10, R13, R17, R122	0	0	RES, 0, 5%, 0.25 W, AEC-Q200 Grade 0, 1206	1206	ERJ-8GEY0 R00V	Panasonic		
R20	0	100k	RES, 100 k, 5%, 0.1 W, AEC-Q200 Grade 0, 0603	0603	CRCW06031 00KJNEA	Vishay-Dale		
R21, R22, R23, R24, R25, R26, R27, R28, R38, R41	0	0	RES, 0, 5%, 0.1 W, AEC-Q200 Grade 0, 0603	0603	CRCW06030 000Z0EA	Vishay-Dale		
R115, R116, R117, R118	0	499	RES, 499, 1%, 0.1 W, 0603	0603	RC0603FR-0 7499RL	Yageo		

Table 9-1. BQ79656EVM BOM (continued)

Designator	Qty	Value	Description	Package Reference	Part Number	Manufacturer	Alternate Part Number ⁽¹⁾	Alternate Manufacturer
T1, T2	0		BMS TRANSFORMER	SMT_TRANSFORMER_8MM89_10MM09	HMU1228NL	Pulse		

(1) Unless otherwise noted in the Alternate PartNumber and/or Alternate Manufacturer columns, all parts can be substituted with equivalents.

10 Revision History

NOTE: Page numbers for previous revisions may differ from page numbers in the current version.

Changes from Revision B (October 2020) to Revision C (August 2023) Page

- Changed all instances of legacy terminology to controller and peripheral where SPI is mentioned..... 1
- Added information about the shunt configurations..... 10

Changes from Revision A (October 2019) to Revision B (October 2020) Page

- Updated the numbering format for tables, figures, and cross-references throughout the document..... 3
- Added BQ79656EVM Schematic, Assembly, Layout, and BOM..... 54

Changes from Revision * (July 2019) to Revision A (October 2019) Page

- Changed instances of BQ79606/BQ79606-Q1 to BQ79606A/BQ79606A-Q1..... 3
- Corrected EVM device typographical errors in the General Description and Host Interface sections.....5
- Added [Section 3](#) 8
- Added cross reference to additional wiring instructions for J15..... 10
- Changed contents of the *Name* column in the *Pin Description* table..... 10
- Added [Section 8](#) 38

STANDARD TERMS FOR EVALUATION MODULES

1. *Delivery:* TI delivers TI evaluation boards, kits, or modules, including any accompanying demonstration software, components, and/or documentation which may be provided together or separately (collectively, an "EVM" or "EVMs") to the User ("User") in accordance with the terms set forth herein. User's acceptance of the EVM is expressly subject to the following terms.
 - 1.1 EVMs are intended solely for product or software developers for use in a research and development setting to facilitate feasibility evaluation, experimentation, or scientific analysis of TI semiconductor products. EVMs have no direct function and are not finished products. EVMs shall not be directly or indirectly assembled as a part or subassembly in any finished product. For clarification, any software or software tools provided with the EVM ("Software") shall not be subject to the terms and conditions set forth herein but rather shall be subject to the applicable terms that accompany such Software
 - 1.2 EVMs are not intended for consumer or household use. EVMs may not be sold, sublicensed, leased, rented, loaned, assigned, or otherwise distributed for commercial purposes by Users, in whole or in part, or used in any finished product or production system.
2. *Limited Warranty and Related Remedies/Disclaimers:*
 - 2.1 These terms do not apply to Software. The warranty, if any, for Software is covered in the applicable Software License Agreement.
 - 2.2 TI warrants that the TI EVM will conform to TI's published specifications for ninety (90) days after the date TI delivers such EVM to User. Notwithstanding the foregoing, TI shall not be liable for a nonconforming EVM if (a) the nonconformity was caused by neglect, misuse or mistreatment by an entity other than TI, including improper installation or testing, or for any EVMs that have been altered or modified in any way by an entity other than TI, (b) the nonconformity resulted from User's design, specifications or instructions for such EVMs or improper system design, or (c) User has not paid on time. Testing and other quality control techniques are used to the extent TI deems necessary. TI does not test all parameters of each EVM. User's claims against TI under this Section 2 are void if User fails to notify TI of any apparent defects in the EVMs within ten (10) business days after delivery, or of any hidden defects with ten (10) business days after the defect has been detected.
 - 2.3 TI's sole liability shall be at its option to repair or replace EVMs that fail to conform to the warranty set forth above, or credit User's account for such EVM. TI's liability under this warranty shall be limited to EVMs that are returned during the warranty period to the address designated by TI and that are determined by TI not to conform to such warranty. If TI elects to repair or replace such EVM, TI shall have a reasonable time to repair such EVM or provide replacements. Repaired EVMs shall be warranted for the remainder of the original warranty period. Replaced EVMs shall be warranted for a new full ninety (90) day warranty period.

WARNING

Evaluation Kits are intended solely for use by technically qualified, professional electronics experts who are familiar with the dangers and application risks associated with handling electrical mechanical components, systems, and subsystems.

User shall operate the Evaluation Kit within TI's recommended guidelines and any applicable legal or environmental requirements as well as reasonable and customary safeguards. Failure to set up and/or operate the Evaluation Kit within TI's recommended guidelines may result in personal injury or death or property damage. Proper set up entails following TI's instructions for electrical ratings of interface circuits such as input, output and electrical loads.

NOTE:

EXPOSURE TO ELECTROSTATIC DISCHARGE (ESD) MAY CAUSE DEGRADATION OR FAILURE OF THE EVALUATION KIT; TI RECOMMENDS STORAGE OF THE EVALUATION KIT IN A PROTECTIVE ESD BAG.

3 Regulatory Notices:

3.1 United States

3.1.1 Notice applicable to EVMs not FCC-Approved:

FCC NOTICE: This kit is designed to allow product developers to evaluate electronic components, circuitry, or software associated with the kit to determine whether to incorporate such items in a finished product and software developers to write software applications for use with the end product. This kit is not a finished product and when assembled may not be resold or otherwise marketed unless all required FCC equipment authorizations are first obtained. Operation is subject to the condition that this product not cause harmful interference to licensed radio stations and that this product accept harmful interference. Unless the assembled kit is designed to operate under part 15, part 18 or part 95 of this chapter, the operator of the kit must operate under the authority of an FCC license holder or must secure an experimental authorization under part 5 of this chapter.

3.1.2 For EVMs annotated as FCC – FEDERAL COMMUNICATIONS COMMISSION Part 15 Compliant:

CAUTION

This device complies with part 15 of the FCC Rules. Operation is subject to the following two conditions: (1) This device may not cause harmful interference, and (2) this device must accept any interference received, including interference that may cause undesired operation.

Changes or modifications not expressly approved by the party responsible for compliance could void the user's authority to operate the equipment.

FCC Interference Statement for Class A EVM devices

NOTE: This equipment has been tested and found to comply with the limits for a Class A digital device, pursuant to part 15 of the FCC Rules. These limits are designed to provide reasonable protection against harmful interference when the equipment is operated in a commercial environment. This equipment generates, uses, and can radiate radio frequency energy and, if not installed and used in accordance with the instruction manual, may cause harmful interference to radio communications. Operation of this equipment in a residential area is likely to cause harmful interference in which case the user will be required to correct the interference at his own expense.

FCC Interference Statement for Class B EVM devices

NOTE: This equipment has been tested and found to comply with the limits for a Class B digital device, pursuant to part 15 of the FCC Rules. These limits are designed to provide reasonable protection against harmful interference in a residential installation. This equipment generates, uses and can radiate radio frequency energy and, if not installed and used in accordance with the instructions, may cause harmful interference to radio communications. However, there is no guarantee that interference will not occur in a particular installation. If this equipment does cause harmful interference to radio or television reception, which can be determined by turning the equipment off and on, the user is encouraged to try to correct the interference by one or more of the following measures:

- Reorient or relocate the receiving antenna.
- Increase the separation between the equipment and receiver.
- Connect the equipment into an outlet on a circuit different from that to which the receiver is connected.
- Consult the dealer or an experienced radio/TV technician for help.

3.2 Canada

3.2.1 For EVMs issued with an Industry Canada Certificate of Conformance to RSS-210 or RSS-247

Concerning EVMs Including Radio Transmitters:

This device complies with Industry Canada license-exempt RSSs. Operation is subject to the following two conditions:

(1) this device may not cause interference, and (2) this device must accept any interference, including interference that may cause undesired operation of the device.

Concernant les EVMs avec appareils radio:

Le présent appareil est conforme aux CNR d'Industrie Canada applicables aux appareils radio exempts de licence. L'exploitation est autorisée aux deux conditions suivantes: (1) l'appareil ne doit pas produire de brouillage, et (2) l'utilisateur de l'appareil doit accepter tout brouillage radioélectrique subi, même si le brouillage est susceptible d'en compromettre le fonctionnement.

Concerning EVMs Including Detachable Antennas:

Under Industry Canada regulations, this radio transmitter may only operate using an antenna of a type and maximum (or lesser) gain approved for the transmitter by Industry Canada. To reduce potential radio interference to other users, the antenna type and its gain should be so chosen that the equivalent isotropically radiated power (e.i.r.p.) is not more than that necessary for successful communication. This radio transmitter has been approved by Industry Canada to operate with the antenna types listed in the user guide with the maximum permissible gain and required antenna impedance for each antenna type indicated. Antenna types not included in this list, having a gain greater than the maximum gain indicated for that type, are strictly prohibited for use with this device.

Concernant les EVMs avec antennes détachables

Conformément à la réglementation d'Industrie Canada, le présent émetteur radio peut fonctionner avec une antenne d'un type et d'un gain maximal (ou inférieur) approuvé pour l'émetteur par Industrie Canada. Dans le but de réduire les risques de brouillage radioélectrique à l'intention des autres utilisateurs, il faut choisir le type d'antenne et son gain de sorte que la puissance isotrope rayonnée équivalente (p.i.r.e.) ne dépasse pas l'intensité nécessaire à l'établissement d'une communication satisfaisante. Le présent émetteur radio a été approuvé par Industrie Canada pour fonctionner avec les types d'antenne énumérés dans le manuel d'usage et ayant un gain admissible maximal et l'impédance requise pour chaque type d'antenne. Les types d'antenne non inclus dans cette liste, ou dont le gain est supérieur au gain maximal indiqué, sont strictement interdits pour l'exploitation de l'émetteur.

3.3 Japan

3.3.1 *Notice for EVMs delivered in Japan:* Please see http://www.tij.co.jp/lstds/ti_ja/general/eStore/notice_01.page 日本国内に輸入される評価用キット、ボードについては、次のところをご覧ください。

<https://www.ti.com/ja-jp/legal/notice-for-evaluation-kits-delivered-in-japan.html>

3.3.2 *Notice for Users of EVMs Considered "Radio Frequency Products" in Japan:* EVMs entering Japan may not be certified by TI as conforming to Technical Regulations of Radio Law of Japan.

If User uses EVMs in Japan, not certified to Technical Regulations of Radio Law of Japan, User is required to follow the instructions set forth by Radio Law of Japan, which includes, but is not limited to, the instructions below with respect to EVMs (which for the avoidance of doubt are stated strictly for convenience and should be verified by User):

1. Use EVMs in a shielded room or any other test facility as defined in the notification #173 issued by Ministry of Internal Affairs and Communications on March 28, 2006, based on Sub-section 1.1 of Article 6 of the Ministry's Rule for Enforcement of Radio Law of Japan,
2. Use EVMs only after User obtains the license of Test Radio Station as provided in Radio Law of Japan with respect to EVMs, or
3. Use of EVMs only after User obtains the Technical Regulations Conformity Certification as provided in Radio Law of Japan with respect to EVMs. Also, do not transfer EVMs, unless User gives the same notice above to the transferee. Please note that if User does not follow the instructions above, User will be subject to penalties of Radio Law of Japan.

【無線電波を送信する製品の開発キットをお使いになる際の注意事項】 開発キットの中には技術基準適合証明を受けていないものがあります。技術適合証明を受けていないものご使用に際しては、電波法遵守のため、以下のいずれかの措置を取っていただく必要がありますのでご注意ください。

1. 電波法施行規則第6条第1項第1号に基づく平成18年3月28日総務省告示第173号で定められた電波暗室等の試験設備でご使用いただく。
2. 実験局の免許を取得後ご使用いただく。
3. 技術基準適合証明を取得後ご使用いただく。

なお、本製品は、上記の「ご使用にあたっての注意」を譲渡先、移転先に通知しない限り、譲渡、移転できないものとします。

上記を遵守頂けない場合は、電波法の罰則が適用される可能性があることをご留意ください。日本テキサス・イ

ンスツルメンツ株式会社

東京都新宿区西新宿 6 丁目 2 4 番 1 号

西新宿三井ビル

3.3.3 *Notice for EVMs for Power Line Communication:* Please see http://www.tij.co.jp/lstds/ti_ja/general/eStore/notice_02.page

電力線搬送波通信についての開発キットをお使いになる際の注意事項については、次のところをご覧ください。 <https://www.ti.com/ja-jp/legal/notice-for-evaluation-kits-for-power-line-communication.html>

3.4 European Union

3.4.1 *For EVMs subject to EU Directive 2014/30/EU (Electromagnetic Compatibility Directive):*

This is a class A product intended for use in environments other than domestic environments that are connected to a low-voltage power-supply network that supplies buildings used for domestic purposes. In a domestic environment this product may cause radio interference in which case the user may be required to take adequate measures.

-
4. *EVM Use Restrictions and Warnings:*
 - 4.1 EVMS ARE NOT FOR USE IN FUNCTIONAL SAFETY AND/OR SAFETY CRITICAL EVALUATIONS, INCLUDING BUT NOT LIMITED TO EVALUATIONS OF LIFE SUPPORT APPLICATIONS.
 - 4.2 User must read and apply the user guide and other available documentation provided by TI regarding the EVM prior to handling or using the EVM, including without limitation any warning or restriction notices. The notices contain important safety information related to, for example, temperatures and voltages.
 - 4.3 *Safety-Related Warnings and Restrictions:*
 - 4.3.1 User shall operate the EVM within TI's recommended specifications and environmental considerations stated in the user guide, other available documentation provided by TI, and any other applicable requirements and employ reasonable and customary safeguards. Exceeding the specified performance ratings and specifications (including but not limited to input and output voltage, current, power, and environmental ranges) for the EVM may cause personal injury or death, or property damage. If there are questions concerning performance ratings and specifications, User should contact a TI field representative prior to connecting interface electronics including input power and intended loads. Any loads applied outside of the specified output range may also result in unintended and/or inaccurate operation and/or possible permanent damage to the EVM and/or interface electronics. Please consult the EVM user guide prior to connecting any load to the EVM output. If there is uncertainty as to the load specification, please contact a TI field representative. During normal operation, even with the inputs and outputs kept within the specified allowable ranges, some circuit components may have elevated case temperatures. These components include but are not limited to linear regulators, switching transistors, pass transistors, current sense resistors, and heat sinks, which can be identified using the information in the associated documentation. When working with the EVM, please be aware that the EVM may become very warm.
 - 4.3.2 EVMs are intended solely for use by technically qualified, professional electronics experts who are familiar with the dangers and application risks associated with handling electrical mechanical components, systems, and subsystems. User assumes all responsibility and liability for proper and safe handling and use of the EVM by User or its employees, affiliates, contractors or designees. User assumes all responsibility and liability to ensure that any interfaces (electronic and/or mechanical) between the EVM and any human body are designed with suitable isolation and means to safely limit accessible leakage currents to minimize the risk of electrical shock hazard. User assumes all responsibility and liability for any improper or unsafe handling or use of the EVM by User or its employees, affiliates, contractors or designees.
 - 4.4 User assumes all responsibility and liability to determine whether the EVM is subject to any applicable international, federal, state, or local laws and regulations related to User's handling and use of the EVM and, if applicable, User assumes all responsibility and liability for compliance in all respects with such laws and regulations. User assumes all responsibility and liability for proper disposal and recycling of the EVM consistent with all applicable international, federal, state, and local requirements.
 5. *Accuracy of Information:* To the extent TI provides information on the availability and function of EVMs, TI attempts to be as accurate as possible. However, TI does not warrant the accuracy of EVM descriptions, EVM availability or other information on its websites as accurate, complete, reliable, current, or error-free.
 6. *Disclaimers:*
 - 6.1 EXCEPT AS SET FORTH ABOVE, EVMS AND ANY MATERIALS PROVIDED WITH THE EVM (INCLUDING, BUT NOT LIMITED TO, REFERENCE DESIGNS AND THE DESIGN OF THE EVM ITSELF) ARE PROVIDED "AS IS" AND "WITH ALL FAULTS." TI DISCLAIMS ALL OTHER WARRANTIES, EXPRESS OR IMPLIED, REGARDING SUCH ITEMS, INCLUDING BUT NOT LIMITED TO ANY EPIDEMIC FAILURE WARRANTY OR IMPLIED WARRANTIES OF MERCHANTABILITY OR FITNESS FOR A PARTICULAR PURPOSE OR NON-INFRINGEMENT OF ANY THIRD PARTY PATENTS, COPYRIGHTS, TRADE SECRETS OR OTHER INTELLECTUAL PROPERTY RIGHTS.
 - 6.2 EXCEPT FOR THE LIMITED RIGHT TO USE THE EVM SET FORTH HEREIN, NOTHING IN THESE TERMS SHALL BE CONSTRUED AS GRANTING OR CONFERRING ANY RIGHTS BY LICENSE, PATENT, OR ANY OTHER INDUSTRIAL OR INTELLECTUAL PROPERTY RIGHT OF TI, ITS SUPPLIERS/LICENSORS OR ANY OTHER THIRD PARTY, TO USE THE EVM IN ANY FINISHED END-USER OR READY-TO-USE FINAL PRODUCT, OR FOR ANY INVENTION, DISCOVERY OR IMPROVEMENT, REGARDLESS OF WHEN MADE, CONCEIVED OR ACQUIRED.
 7. *USER'S INDEMNITY OBLIGATIONS AND REPRESENTATIONS.* USER WILL DEFEND, INDEMNIFY AND HOLD TI, ITS LICENSORS AND THEIR REPRESENTATIVES HARMLESS FROM AND AGAINST ANY AND ALL CLAIMS, DAMAGES, LOSSES, EXPENSES, COSTS AND LIABILITIES (COLLECTIVELY, "CLAIMS") ARISING OUT OF OR IN CONNECTION WITH ANY HANDLING OR USE OF THE EVM THAT IS NOT IN ACCORDANCE WITH THESE TERMS. THIS OBLIGATION SHALL APPLY WHETHER CLAIMS ARISE UNDER STATUTE, REGULATION, OR THE LAW OF TORT, CONTRACT OR ANY OTHER LEGAL THEORY, AND EVEN IF THE EVM FAILS TO PERFORM AS DESCRIBED OR EXPECTED.

8. *Limitations on Damages and Liability:*

8.1 *General Limitations.* IN NO EVENT SHALL TI BE LIABLE FOR ANY SPECIAL, COLLATERAL, INDIRECT, PUNITIVE, INCIDENTAL, CONSEQUENTIAL, OR EXEMPLARY DAMAGES IN CONNECTION WITH OR ARISING OUT OF THESE TERMS OR THE USE OF THE EVMS , REGARDLESS OF WHETHER TI HAS BEEN ADVISED OF THE POSSIBILITY OF SUCH DAMAGES. EXCLUDED DAMAGES INCLUDE, BUT ARE NOT LIMITED TO, COST OF REMOVAL OR REINSTALLATION, ANCILLARY COSTS TO THE PROCUREMENT OF SUBSTITUTE GOODS OR SERVICES, RETESTING, OUTSIDE COMPUTER TIME, LABOR COSTS, LOSS OF GOODWILL, LOSS OF PROFITS, LOSS OF SAVINGS, LOSS OF USE, LOSS OF DATA, OR BUSINESS INTERRUPTION. NO CLAIM, SUIT OR ACTION SHALL BE BROUGHT AGAINST TI MORE THAN TWELVE (12) MONTHS AFTER THE EVENT THAT GAVE RISE TO THE CAUSE OF ACTION HAS OCCURRED.

8.2 *Specific Limitations.* IN NO EVENT SHALL TI'S AGGREGATE LIABILITY FROM ANY USE OF AN EVM PROVIDED HEREUNDER, INCLUDING FROM ANY WARRANTY, INDEMNITY OR OTHER OBLIGATION ARISING OUT OF OR IN CONNECTION WITH THESE TERMS, , EXCEED THE TOTAL AMOUNT PAID TO TI BY USER FOR THE PARTICULAR EVM(S) AT ISSUE DURING THE PRIOR TWELVE (12) MONTHS WITH RESPECT TO WHICH LOSSES OR DAMAGES ARE CLAIMED. THE EXISTENCE OF MORE THAN ONE CLAIM SHALL NOT ENLARGE OR EXTEND THIS LIMIT.

9. *Return Policy.* Except as otherwise provided, TI does not offer any refunds, returns, or exchanges. Furthermore, no return of EVM(s) will be accepted if the package has been opened and no return of the EVM(s) will be accepted if they are damaged or otherwise not in a resalable condition. If User feels it has been incorrectly charged for the EVM(s) it ordered or that delivery violates the applicable order, User should contact TI. All refunds will be made in full within thirty (30) working days from the return of the components(s), excluding any postage or packaging costs.

10. *Governing Law:* These terms and conditions shall be governed by and interpreted in accordance with the laws of the State of Texas, without reference to conflict-of-laws principles. User agrees that non-exclusive jurisdiction for any dispute arising out of or relating to these terms and conditions lies within courts located in the State of Texas and consents to venue in Dallas County, Texas. Notwithstanding the foregoing, any judgment may be enforced in any United States or foreign court, and TI may seek injunctive relief in any United States or foreign court.

Mailing Address: Texas Instruments, Post Office Box 655303, Dallas, Texas 75265
Copyright © 2023, Texas Instruments Incorporated

IMPORTANT NOTICE AND DISCLAIMER

TI PROVIDES TECHNICAL AND RELIABILITY DATA (INCLUDING DATA SHEETS), DESIGN RESOURCES (INCLUDING REFERENCE DESIGNS), APPLICATION OR OTHER DESIGN ADVICE, WEB TOOLS, SAFETY INFORMATION, AND OTHER RESOURCES "AS IS" AND WITH ALL FAULTS, AND DISCLAIMS ALL WARRANTIES, EXPRESS AND IMPLIED, INCLUDING WITHOUT LIMITATION ANY IMPLIED WARRANTIES OF MERCHANTABILITY, FITNESS FOR A PARTICULAR PURPOSE OR NON-INFRINGEMENT OF THIRD PARTY INTELLECTUAL PROPERTY RIGHTS.

These resources are intended for skilled developers designing with TI products. You are solely responsible for (1) selecting the appropriate TI products for your application, (2) designing, validating and testing your application, and (3) ensuring your application meets applicable standards, and any other safety, security, regulatory or other requirements.

These resources are subject to change without notice. TI grants you permission to use these resources only for development of an application that uses the TI products described in the resource. Other reproduction and display of these resources is prohibited. No license is granted to any other TI intellectual property right or to any third party intellectual property right. TI disclaims responsibility for, and you will fully indemnify TI and its representatives against, any claims, damages, costs, losses, and liabilities arising out of your use of these resources.

TI's products are provided subject to [TI's Terms of Sale](#) or other applicable terms available either on [ti.com](https://www.ti.com) or provided in conjunction with such TI products. TI's provision of these resources does not expand or otherwise alter TI's applicable warranties or warranty disclaimers for TI products.

TI objects to and rejects any additional or different terms you may have proposed.

Mailing Address: Texas Instruments, Post Office Box 655303, Dallas, Texas 75265
Copyright © 2023, Texas Instruments Incorporated

Looking for pricing, stock, or lifecycle information?

Click below to explore more details on WIN SOURCE:

 [View BQ75614EVM-021](#) on WIN SOURCE

 [Texas Instruments](#) Information

Optimize Your Supply Chain with WIN SOURCE Solutions

-  Global Sourcing Solution
-  Obsolete Management
-  Cost Control Management
-  Shortage Management
-  Alternative Solution
-  Excess Inventory Management