



**THE DATASHEET OF  
UCC5870QEVM-045**





Gangyao Wang

**ABSTRACT**

The evaluation module is designed for evaluation of TI's functional safety compliant 15-A isolated single-channel gate driver UCC5870-Q1 with advanced protection functions. This gate driver is targeted to drive high power SiC MOSFETs or Si IGBTs in EV/HEV applications. Protection functions such as DESAT short circuit protection, shunt current sensing support, soft turn-off, VCE overvoltage clamping, UVLO and OVLO of gate driver power supplies, temperature monitoring and thermal shutdown, and gate monitoring are included to support system's demanding high reliability. This driver also incorporates sophisticated diagnostic, protection, and monitoring features through a serial peripheral interface (SPI).

The UCC5870-Q1-045 evaluation module includes six channel gate drivers which can be used for driving a three phase converter. This evaluation module can be connected with a C2000 LaunchPad LAUNCHXL-F28379D directly for programming the drivers and generating PWMs. The evaluation module also has pin outputs to connect different types of controllers. The board has the option to support both address mode SPI and daisy-chain mode SPI communication between the drivers and the controller.

This evaluation module also uses the LM5180-Q1 PSR flyback converter with wide input voltage (wide VIN) range. An integrated 100-V, 1.5-A power MOSFET provides ample margin for line transients and switch (SW) node voltage spikes related to transformer parasitic leakage inductance. Load regulation errors related to transformer secondary winding resistance are avoided by virtue of the quasi-resonant boundary conduction mode (BCM) control scheme.

**Table of Contents**

<b>1 Description</b> .....	3
<b>2 Electrical Specifications</b> .....	4
<b>3 Test Equipment, Setup and Example Waveforms</b> .....	4
<b>4 EVM Other Configuration Option: Using Other MCU Control Board</b> .....	6
<b>5 Schematic</b> .....	7
<b>6 Layout Diagrams</b> .....	9
<b>7 Bill of Materials</b> .....	12

**List of Figures**

Figure 3-1. Bench Setup Configuration.....	5
Figure 3-2. Gate Waveforms for Driver Channels Ch1, Ch3, Ch5.....	5
Figure 4-1. J4 Connector Pin Definition.....	6
Figure 5-1. EVM Top Level Schematic for all Six Drivers.....	7
Figure 5-2. EVM One Driver Block Schematic.....	8
Figure 6-1. PCB Layout Top Overlay.....	9
Figure 6-2. PCB Layout Top Layer.....	9
Figure 6-3. PCB Layout Inter Layer 1.....	10
Figure 6-4. PCB Layout Inter Layer 2.....	10
Figure 6-5. PCB Layout Bottom Layer.....	11
Figure 6-6. PCB Layout Bottom Overlay.....	11

**List of Tables**

Table 1-1. I/O Description.....	3
Table 2-1. UCC5870 EVM Electrical Specifications.....	4
Table 7-1. List of Materials.....	12

## **Trademarks**

All trademarks are the property of their respective owners.

## 1 Description

The UCC5870-Q1-045 evaluation module is designed to test six channels of the UCC5870-Q1 gate drivers with TI address mode SPI communication, and has the option to configure the board for daisy chain mode SPI communication. The board can directly fit C2000 LaunchPad LAUNCHXL-F28379D, but also provides connectors for other type of controllers.

### 1.1 Features

- 15-A peak split sink/source drive current for fast turn ON and turn OFF time
- Driver output voltages by default are +15V/-8V with 12-V input supply
- 3750- $V_{RMS}$  one minute isolation per UL 1577 for UCC5870-Q1
- 3000- $V_{RMS}$  one minute isolation for the flyback transformer
- > 8-mm creepage distance between primary and secondary
- Desat short-circuit protection and active Vce clamp
- Active miller clamp using internal or external FET
- Fault feedback and reset
- ADC for temperature sensing and DC bus voltage sensing
- Primary and secondary ASC
- Address mode or daisy chain mode SPI based device reconfiguration, verification, supervision and diagnosis
- Compatible with C2000 LaunchPad LAUNCHXL-F28379D
- Tightly-regulated, isolated output voltages of 15 V and -7.7 V with better than  $\pm 2\%$  load regulation from 1% to 100% load

### 1.2 I/O Description

**Table 1-1. I/O Description**

PINS	DESCRIPTION
PWR1-1	+12V supply
PWR1-2	+3.3V supply
PWR1-3	GND1
J1/J3, J2/J4, J5/J7, J6/J8	Connectors for C2000 LaunchPad LAUNCHXL-F28379D
J4	Connector for connecting other type controller board
J1_1, J1_2, J1_3, J1_4, J1_5, J1_6	Connectors for connecting IGBTs/MOSFETs for each channel: pin1: Collector/Drain; pin2: Gate; pin3: Emitter/Source
J2_1, J2_2, J2_3, J2_4, J2_5, J2_6	Connectors for connecting ADC sources for each channel: pin1: AI1; pin2: AI2; pin3: AI3; pin4: AI5; pin5: AI6
TP-1	Test point for SPI nCS
TP-2	Test point for SPI SCLK
TP-3	Test point for SPI SDI
TP-4	Test point for SPI SDO
TP-5	GND1
TP-6	High side nFLT1
TP-7	High side nFLT2
TP-8	Low side nFLT1
TP-9	Low side nFLT2
TP-10	High side ASC Enable
TP-11	Low side ASC Enable
TP-12	High side ASC
TP-13	Low side ASC

## 2 Electrical Specifications

**Table 2-1. UCC5870 EVM Electrical Specifications**

DESCRIPTION		MIN	TYP	MAX	UNIT
PWR1-2: 3.3V power supply	Primary-side VCC1 power supply	3.0	3.3	5.5	V
PWR1-1: 12V power supply	Input power supply for driver VCC2 and VEE2	10	12	15	V
F <sub>s</sub>	Switching frequency	0		50 <sup>(1)</sup>	kHz
T <sub>j</sub>	Operating junction temperature range for UCC5870-Q1	-40		150	°C

(1) 30kHz if ADC is used

## 3 Test Equipment, Setup and Example Waveforms

In this section, the EVM is tested in its default configuration with TI address mode SPI and C2000 LaunchPad LAUNCHXL-F28379D controller.

### 3.1 Equipment

#### 3.1.1 Power Supplies

Two DC power supplies with voltage/current above 5-V/0.5-A and 35-V/0.5-A (for example: Agilent E3634A)

#### 3.1.2 LaunchPad LAUNCHXL-F28379D and a Computer

LaunchPad LAUNCHXL-F28379D and one computer with Windows system and TI Code Composer Studio installed: <https://www.ti.com/tool/CCSTUDIO>.

### 3.2 Test Setup

#### 3.2.1 DC Power Supply Settings

- DC power supply #1
  - Voltage setting: 3.3-V, as the driver VCC1 power supply.
  - Current limit: 0.2-A
- DC power supply #2
  - Voltage setting: 12-V, as the input of the flyback power supply on the board
  - Current limit: 0.5 A

#### 3.2.2 Bench Setup For The Test

The bench setup includes power supplies, oscilloscope and LaunchPad USB connections.

Follow the connection procedure below. [Figure 3-1](#) can be used as a reference.

- Make sure the outputs of DC voltage power supplies are off before connection;
- Connect 12V and 3.3V power supplies;
- Plug in the LaunchPad LAUNCHXL-F28379D on top of the EVM board;
- Connect oscilloscope probes to corresponding test pins;
- Connect the LaunchPad LAUNCHXL-F28379D to computer through USB cable.

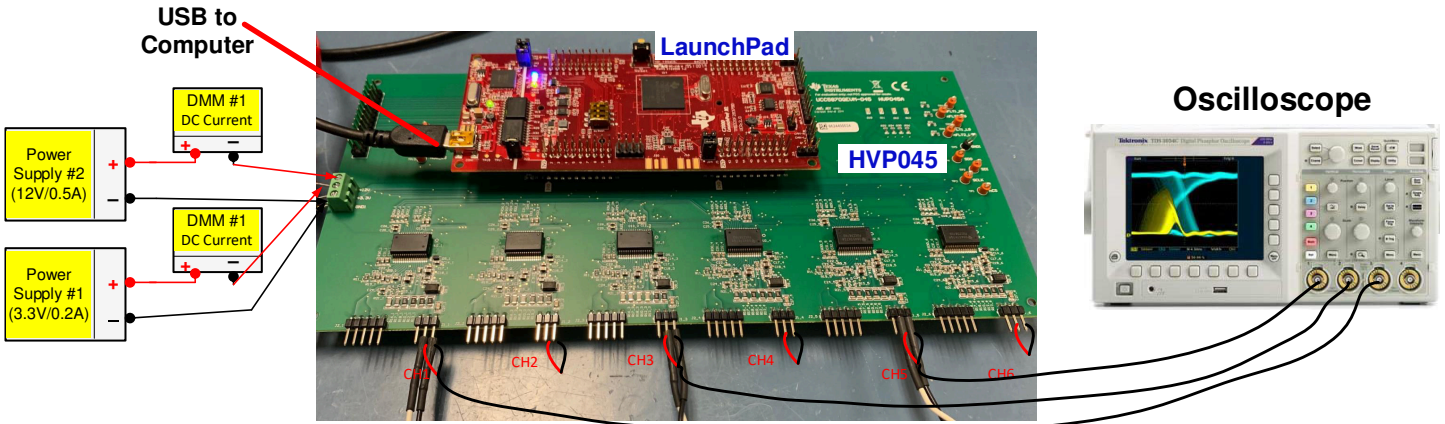

Figure 3-1. Bench Setup Configuration

### 3.3 Test Example Waveforms

After configuring and programming the gate drivers through the Launchpad and Code Composer Studio (CCS), the drivers will output PWMs. Figure 3-2 shows an example of 5kHz 50% duty cycle PWM waveforms for all channels. The example only captures V<sub>ge</sub>/V<sub>gs</sub> waveforms for driver channels Ch1, Ch3, and Ch5, but the other three channels will have similar waveforms. Under this test condition, the 3.3V power supply outputs about 29mA current and 12V power supply outputs about 126mA current. Driver output high voltage is 15V and low voltage is -7.7V for all channels.



Figure 3-2. Gate Waveforms for Driver Channels Ch1, Ch3, Ch5

## 4 EVM Other Configuration Option: Using Other MCU Control Board

This EVM could also be connected with a different MCU control board by using the J4 connector which includes pins for all SPI, PWM, Fault and ASC signals connection. The detailed definition is shown as in [Figure 4-1](#).

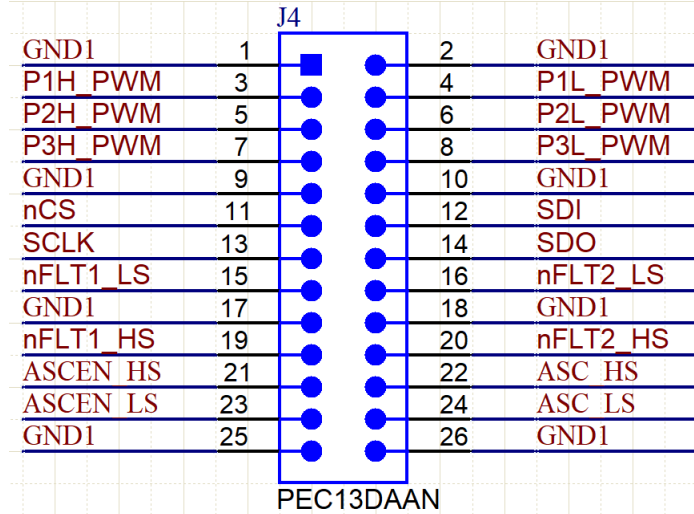

**Figure 4-1. J4 Connector Pin Definition**

## 5 Schematic

Figure 5-1 shows the top level schematic diagram for all six channels and Figure 5-2 shows the driver block schematic for one of the channel.

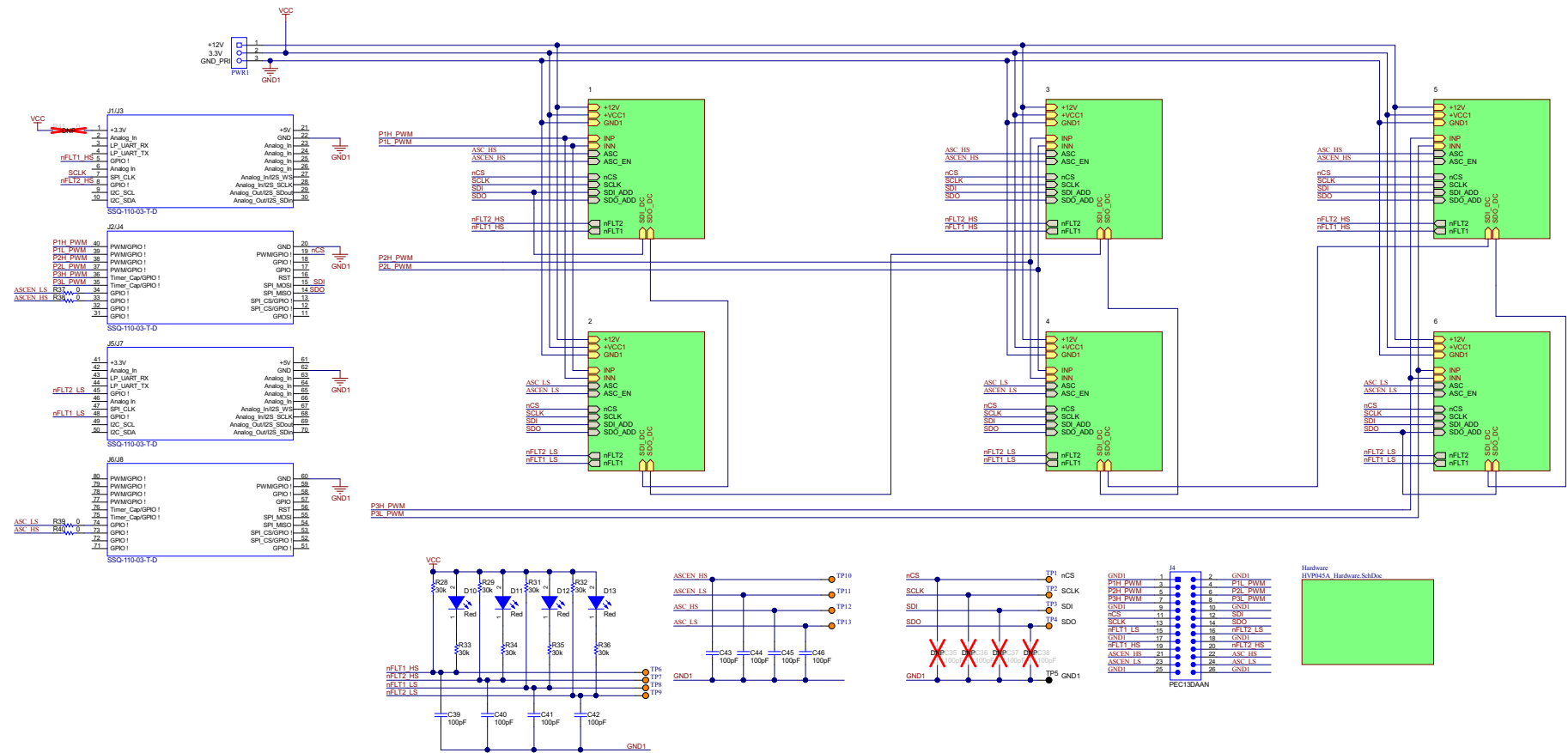

Figure 5-1. EVM Top Level Schematic for all Six Drivers

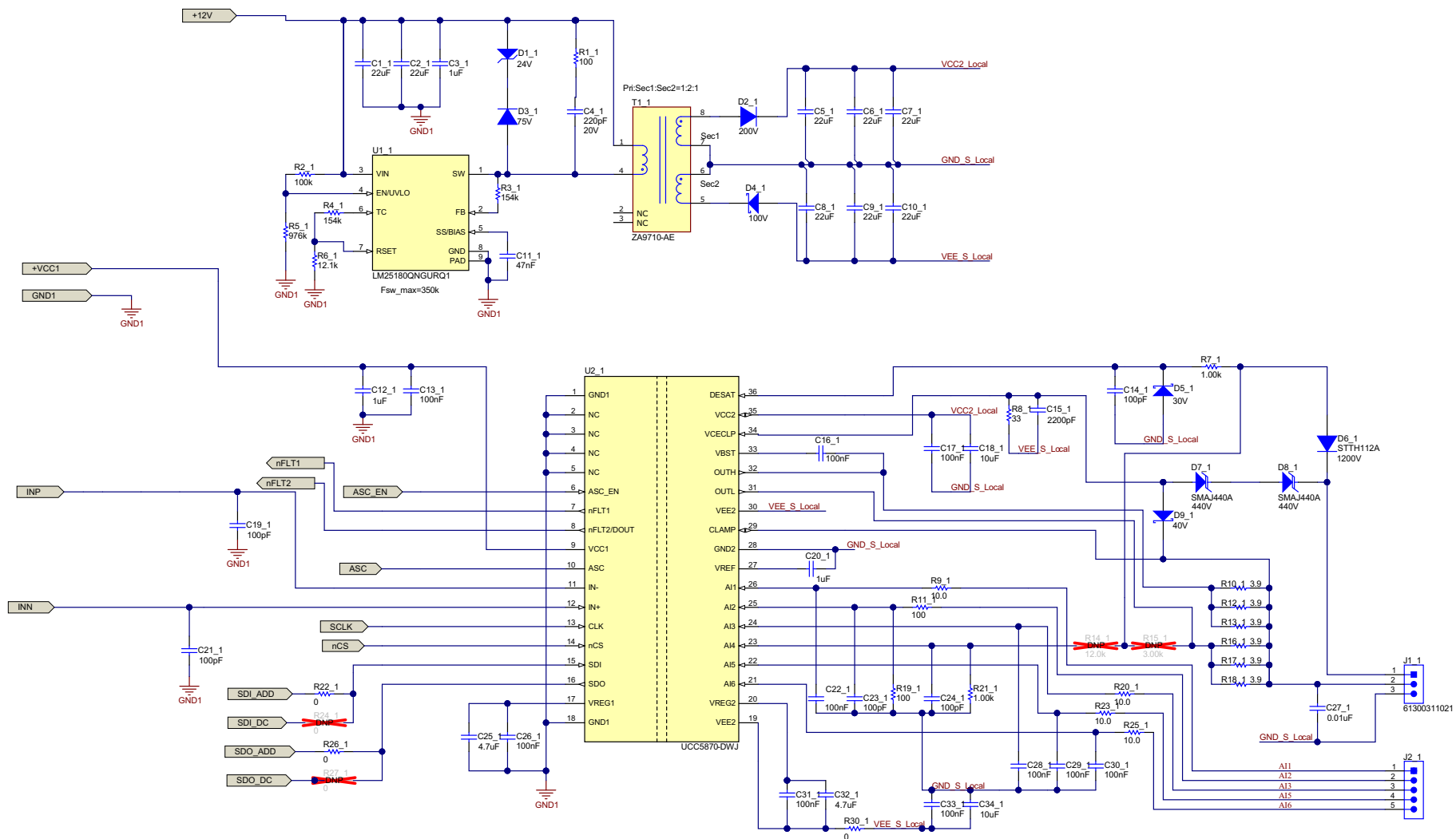

Figure 5-2. EVM One Driver Block Schematic

## 6 Layout Diagrams

Figure 6-1 to Figure 6-6 show the PCB layout information for the UCC5870-045 EVM.

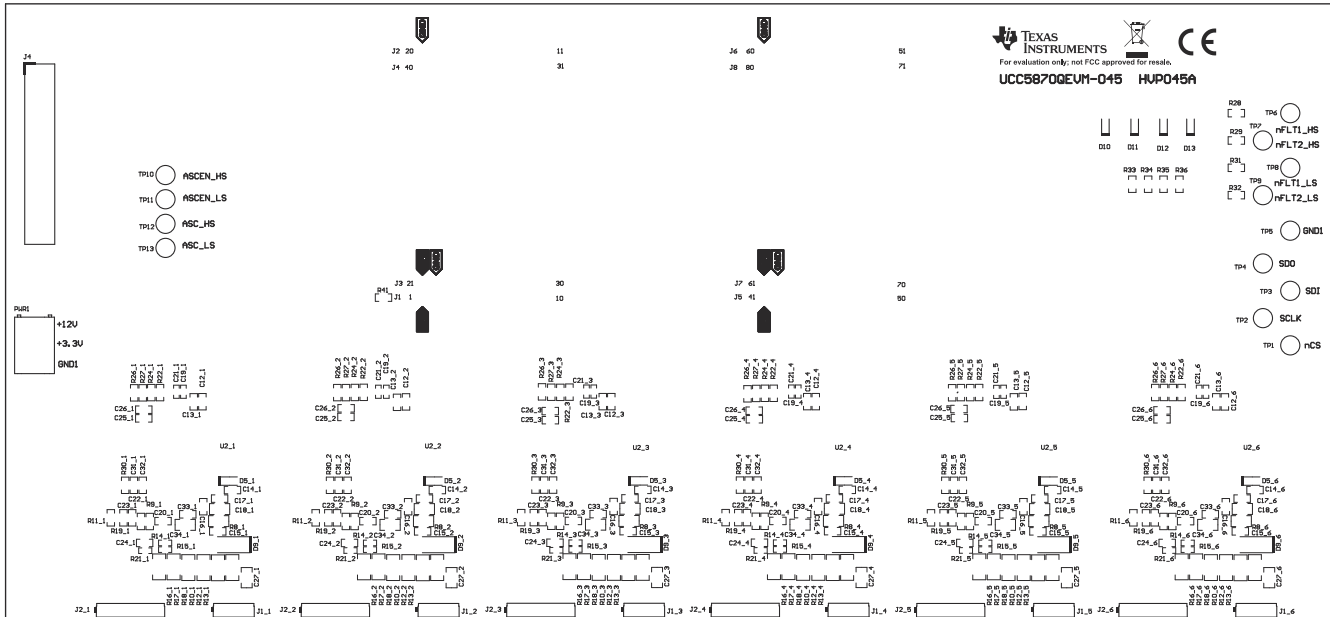

Figure 6-1. PCB Layout Top Overlay

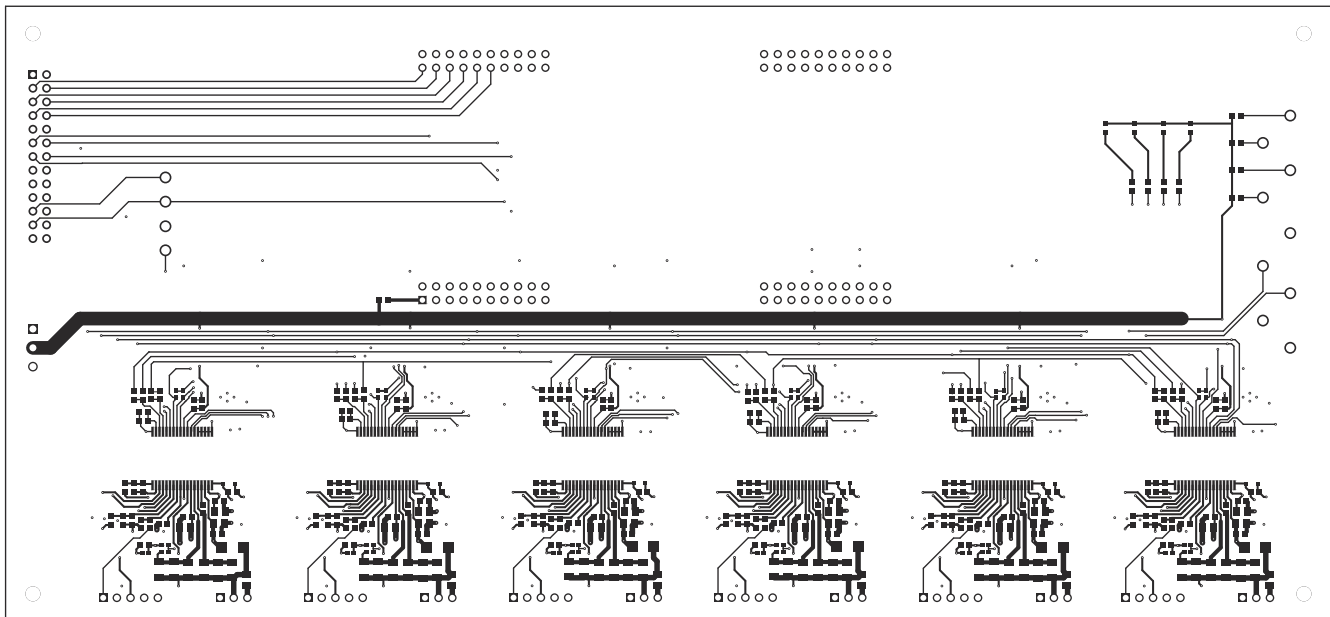

Figure 6-2. PCB Layout Top Layer

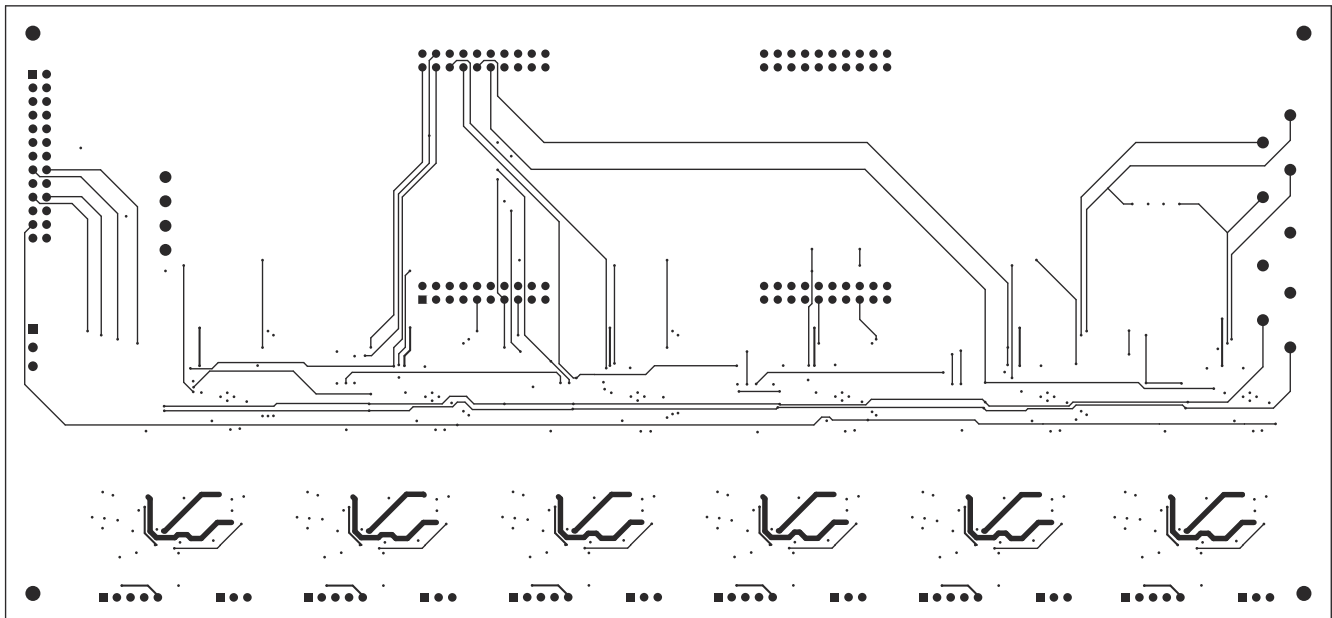

Figure 6-3. PCB Layout Inter Layer 1

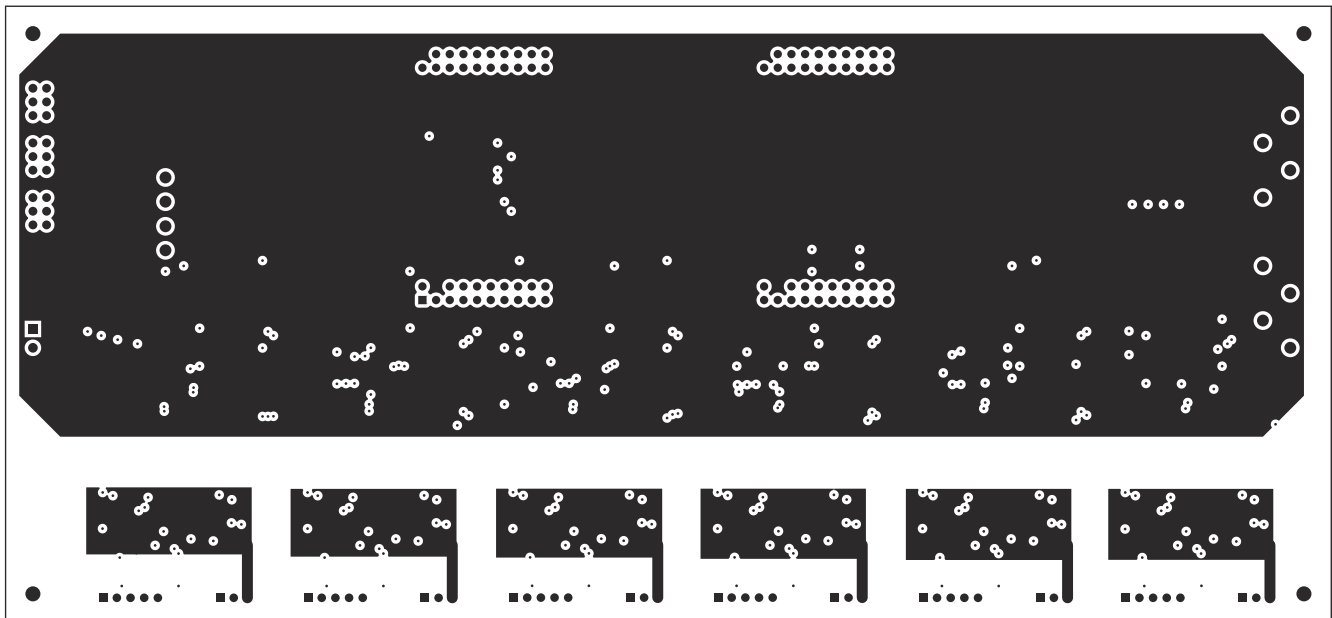

Figure 6-4. PCB Layout Inter Layer 2



## 7 Bill of Materials

**Table 7-1. List of Materials**

DES	QTY	DESCRIPTION	MANUFACTURE R	PART NUMBER
C1_1, C1_2, C1_3, C1_4, C1_5, C1_6, C2_1, C2_2, C2_3, C2_4, C2_5, C2_6, C5_1, C5_2, C5_3, C5_4, C5_5, C5_6, C6_1, C6_2, C6_3, C6_4, C6_5, C6_6, C7_1, C7_2, C7_3, C7_4, C7_5, C7_6, C8_1, C8_2, C8_3, C8_4, C8_5, C8_6, C9_1, C9_2, C9_3, C9_4, C9_5, C9_6, C10_1, C10_2, C10_3, C10_4, C10_5, C10_6	48	CAP, CERM, 22 uF, 25 V, +/- 20%, X5R, 0805	MuRata	GRM21BR61E226ME44L
C3_1, C3_2, C3_3, C3_4, C3_5, C3_6, C12_1, C12_2, C12_3, C12_4, C12_5, C12_6, C20_1, C20_2, C20_3, C20_4, C20_5, C20_6	18	CAP, CERM, 1 uF, 35 V, +/- 10%, X7R, AEC-Q200 Grade 1, 0603	TDK	CGA3E1X7R1V105K080A C
C4_1, C4_2, C4_3, C4_4, C4_5, C4_6	6	CAP, CERM, 220 pF, 20 V, +/- 5%, C0G/NP0, AEC-Q200 Grade 1, 0603	TDK	CGA3E2C0G1H221J080A A
C11_1, C11_2, C11_3, C11_4, C11_5, C11_6	6	CAP, CERM, 0.047 uF, 50 V, +/- 10%, X7R, 0603	TDK	C1608X7R1H473K080AA
C13_1, C13_2, C13_3, C13_4, C13_5, C13_6, C16_1, C16_2, C16_3, C16_4, C16_5, C16_6, C17_1, C17_2, C17_3, C17_4, C17_5, C17_6, C22_1, C22_2, C22_3, C22_4, C22_5, C22_6, C26_1, C26_2, C26_3, C26_4, C26_5, C26_6, C28_1, C28_2, C28_3, C28_4, C28_5, C28_6, C29_1, C29_2, C29_3, C29_4, C29_5, C29_6, C30_1, C30_2, C30_3, C30_4, C30_5, C30_6, C31_1, C31_2, C31_3, C31_4, C31_5, C31_6, C33_1, C33_2, C33_3, C33_4, C33_5, C33_6	60	CAP, CERM, 0.1 uF, 50 V, +/- 10%, X7R, 0603	Würth Elektronik	885012206095
C14_1, C14_2, C14_3, C14_4, C14_5, C14_6, C23_1, C23_2, C23_3, C23_4, C23_5, C23_6, C24_1, C24_2, C24_3, C24_4, C24_5, C24_6, C39, C40, C41, C42, C43, C44, C45, C46	26	CAP, CERM, 100 pF, 50 V, +/- 5%, C0G/NP0, 0603	Würth Elektronik	885012006057
C15_1, C15_2, C15_3, C15_4, C15_5, C15_6	6	CAP, CERM, 2200 pF, 50 V, +/- 5%, C0G/NP0, 0603	MuRata	GRM1885C1H222JA01D
C18_1, C18_2, C18_3, C18_4, C18_5, C18_6, C34_1, C34_2, C34_3, C34_4, C34_5, C34_6	12	CAP, CERM, 10 uF, 35 V, +/- 10%, X5R, 0805	MuRata	GRM21BR6YA106KE43L

Table 7-1. List of Materials (continued)

DES	QTY	DESCRIPTION	MANUFACTURER	PART NUMBER
C19_1, C19_2, C19_3, C19_4, C19_5, C19_6, C21_1, C21_2, C21_3, C21_4, C21_5, C21_6	12	CAP, CERM, 100 pF, 50 V, +/- 5%, C0G/NP0, 0402	Yageo America	CC0402JRNPO9BN101
C25_1, C25_2, C25_3, C25_4, C25_5, C25_6, C32_1, C32_2, C32_3, C32_4, C32_5, C32_6	12	CAP, CERM, 4.7 uF, 6.3 V, +/- 10%, X5R, 0603	Kemet	C0603C475K9PACTU
C27_1, C27_2, C27_3, C27_4, C27_5, C27_6	6	CAP, CERM, 0.01 uF, 50 V, +/- 10%, X7R, 0805	Würth Elektronik	885012207092
D1_1, D1_2, D1_3, D1_4, D1_5, D1_6	6	Diode, Zener, 24 V, 1 W, PowerDI123	Diodes Inc.	DFLZ24-7
D2_1, D2_2, D2_3, D2_4, D2_5, D2_6	6	Diode, Superfast Rectifier, 200 V, 1 A, AEC-Q101, PowerDI123	Diodes Inc.	DFLU1200-7
D3_1, D3_2, D3_3, D3_4, D3_5, D3_6	6	Diode, Ultrafast, 75 V, 0.25 A, SOD-323	Central Semiconductor	CMDD4448
D4_1, D4_2, D4_3, D4_4, D4_5, D4_6	6	Diode, Schottky, 100 V, 1 A, AEC-Q101, SOD-123W	Nexperia	PMEG10010ELRX
D5_1, D5_2, D5_3, D5_4, D5_5, D5_6	6	Diode, Schottky, 30 V, 0.2 A, SOD-323	Diodes Inc.	BAT54WS-7-F
D6_1, D6_2, D6_3, D6_4, D6_5, D6_6	6	Diode, Ultrafast, 1200 V, 1 A, SMA	STMicroelectronics	STTH112A
D7_1, D7_2, D7_3, D7_4, D7_5, D7_6, D8_1, D8_2, D8_3, D8_4, D8_5, D8_6	12	Diode, TVS, Uni, 440 V, 713 Vc, 400 W, 0.6 A, SMA	Littelfuse	SMAJ440A
D9_1, D9_2, D9_3, D9_4, D9_5, D9_6	6	Diode, Schottky, 40 V, 3 A, SMA	ON Semiconductor	MBRA340T3G
D10, D11, D12, D13	4	LED, Red, SMD	Würth Elektronik	150060RS75000
J1/J3, J2/J4, J5/J7, J6/J8	4	Receptacle, 2.54mm, 10x2, Tin, TH	Samtec	SSQ-110-03-T-D
J1_1, J1_2, J1_3, J1_4, J1_5, J1_6	6	Header, 2.54 mm, 3x1, Gold, R/A, TH	Würth Elektronik	61300311021
J2_1, J2_2, J2_3, J2_4, J2_5, J2_6	6	Header, 2.54 mm, 5x1, Gold, R/A, TH	Würth Elektronik	61300511021
J4	1	Header, 100mil, 13x2, Tin, TH	Sullins Connector Solutions	PEC13DAAN
PWR1	1	Terminal Block, 3.5mm, 3x1, Tin, TH	Würth Elektronik	691214110003
R1_1, R1_2, R1_3, R1_4, R1_5, R1_6	6	RES, 100, 1%, 0.125 W, AEC-Q200 Grade 0, 0805	Vishay-Dale	CRCW0805100RFKEA
R2_1, R2_2, R2_3, R2_4, R2_5, R2_6	6	RES, 100 k, 1%, 0.125 W, AEC-Q200 Grade 0, 0805	Panasonic	ERJ-6ENF1003V
R3_1, R3_2, R3_3, R3_4, R3_5, R3_6, R4_1, R4_2, R4_3, R4_4, R4_5, R4_6	12	RES, 154 k, 1%, 0.1 W, 0603	Yageo	RC0603FR-07154KL
R5_1, R5_2, R5_3, R5_4, R5_5, R5_6	6	RES, 976 k, 1%, 0.1 W, AEC-Q200 Grade 0, 0603	Vishay-Dale	CRCW0603976KFKEA
R6_1, R6_2, R6_3, R6_4, R6_5, R6_6	6	RES, 12.1 k, 1%, 0.1 W, AEC-Q200 Grade 0, 0603	Vishay-Dale	CRCW060312K1FKEA
R7_1, R7_2, R7_3, R7_4, R7_5, R7_6	6	RES, 1.00 k, 1%, 0.125 W, AEC-Q200 Grade 0, 0805	Vishay-Dale	CRCW08051K00FKEA
R8_1, R8_2, R8_3, R8_4, R8_5, R8_6	6	RES, 33, 5%, 0.125 W, AEC-Q200 Grade 0, 0805	Vishay-Dale	CRCW080533R0JNEA

**Table 7-1. List of Materials (continued)**

DES	QTY	DESCRIPTION	MANUFACTURE R	PART NUMBER
R9_1, R9_2, R9_3, R9_4, R9_5, R9_6, R20_1, R20_2, R20_3, R20_4, R20_5, R20_6, R23_1, R23_2, R23_3, R23_4, R23_5, R23_6, R25_1, R25_2, R25_3, R25_4, R25_5, R25_6	24	RES, 10.0, 1%, 0.1 W, AEC-Q200 Grade 0, 0603	Vishay-Dale	CRCW060310R0FKEA
R10_1, R10_2, R10_3, R10_4, R10_5, R10_6, R12_1, R12_2, R12_3, R12_4, R12_5, R12_6, R13_1, R13_2, R13_3, R13_4, R13_5, R13_6, R16_1, R16_2, R16_3, R16_4, R16_5, R16_6, R17_1, R17_2, R17_3, R17_4, R17_5, R17_6, R18_1, R18_2, R18_3, R18_4, R18_5, R18_6	36	RES, 3.9, 5%, 0.25 W, AEC-Q200 Grade 0, 1206	Vishay-Dale	CRCW12063R90JNEA
R11_1, R11_2, R11_3, R11_4, R11_5, R11_6, R19_1, R19_2, R19_3, R19_4, R19_5, R19_6	12	RES, 100, 1%, 0.1 W, AEC-Q200 Grade 0, 0603	Vishay-Dale	CRCW0603100RFKEA
R21_1, R21_2, R21_3, R21_4, R21_5, R21_6	6	RES, 1.00 k, 1%, 0.063 W, AEC-Q200 Grade 0, 0402	Vishay-Dale	CRCW04021K00FKED
R22_1, R22_2, R22_3, R22_4, R22_5, R22_6, R26_1, R26_2, R26_3, R26_4, R26_5, R26_6, R30_1, R30_2, R30_3, R30_4, R30_5, R30_6, R37, R38, R39, R40	22	RES, 0, 5%, 0.1 W, AEC-Q200 Grade 0, 0603	Vishay-Dale	CRCW06030000Z0EA
R28, R29, R31, R32, R33, R34, R35, R36	8	RES, 30 k, 5%, 0.1 W, AEC-Q200 Grade 0, 0603	Vishay-Dale	CRCW060330K0JNEA
T1_1, T1_2, T1_3, T1_4, T1_5, T1_6	6	Flyback Transformer	Coilcraft	ZA9710-AE
TP1, TP2, TP3, TP4, TP6, TP7, TP8, TP9, TP10, TP11, TP12, TP13	12	Test Point, Compact, Orange, TH	Keystone	5008
TP5	1	Test Point, Multipurpose, Black, TH	Keystone	5011
U1_1, U1_2, U1_3, U1_4, U1_5, U1_6	6	LM25180-Q1 42-VIN PSR Flyback DC/DC Converter With 65-V, 1.5-A Integrated MOSFET, NGU0008C (WSO8)	Texas Instruments	LM25180QNGURQ1
U2_1, U2_2, U2_3, U2_4, U2_5, U2_6	6	Isolated IGBT, SiC MOSFET Gate Driver With Real-Time Programmability, DWJ0036A (SOIC-36)	Texas Instruments	UCC5870-DWJ
C35, C36, C37, C38	0	CAP, CERM, 100 pF, 50 V, +/- 5%, COG/NP0, 0603	Würth Elektronik	885012006057
FID1, FID2, FID3	0	Fiducial mark. There is nothing to buy or mount.	N/A	N/A
R14_1, R14_2, R14_3, R14_4, R14_5, R14_6	0	RES, 12.0 k, 1%, 0.063 W, AEC-Q200 Grade 0, 0402	Vishay-Dale	CRCW040212K0FKED
R15_1, R15_2, R15_3, R15_4, R15_5, R15_6	0	RES, 3.00 k, 1%, 0.063 W, AEC-Q200 Grade 0, 0402	Vishay-Dale	CRCW04023K00FKED
R24_1, R24_2, R24_3, R24_4, R24_5, R24_6, R27_1, R27_2, R27_3, R27_4, R27_5, R27_6, R41	0	RES, 0, 5%, 0.1 W, AEC-Q200 Grade 0, 0603	Vishay-Dale	CRCW06030000Z0EA

## IMPORTANT NOTICE AND DISCLAIMER

TI PROVIDES TECHNICAL AND RELIABILITY DATA (INCLUDING DATA SHEETS), DESIGN RESOURCES (INCLUDING REFERENCE DESIGNS), APPLICATION OR OTHER DESIGN ADVICE, WEB TOOLS, SAFETY INFORMATION, AND OTHER RESOURCES "AS IS" AND WITH ALL FAULTS, AND DISCLAIMS ALL WARRANTIES, EXPRESS AND IMPLIED, INCLUDING WITHOUT LIMITATION ANY IMPLIED WARRANTIES OF MERCHANTABILITY, FITNESS FOR A PARTICULAR PURPOSE OR NON-INFRINGEMENT OF THIRD PARTY INTELLECTUAL PROPERTY RIGHTS.

These resources are intended for skilled developers designing with TI products. You are solely responsible for (1) selecting the appropriate TI products for your application, (2) designing, validating and testing your application, and (3) ensuring your application meets applicable standards, and any other safety, security, regulatory or other requirements.

These resources are subject to change without notice. TI grants you permission to use these resources only for development of an application that uses the TI products described in the resource. Other reproduction and display of these resources is prohibited. No license is granted to any other TI intellectual property right or to any third party intellectual property right. TI disclaims responsibility for, and you will fully indemnify TI and its representatives against, any claims, damages, costs, losses, and liabilities arising out of your use of these resources.

TI's products are provided subject to [TI's Terms of Sale](#) or other applicable terms available either on [ti.com](http://ti.com) or provided in conjunction with such TI products. TI's provision of these resources does not expand or otherwise alter TI's applicable warranties or warranty disclaimers for TI products.

TI objects to and rejects any additional or different terms you may have proposed.

Mailing Address: Texas Instruments, Post Office Box 655303, Dallas, Texas 75265  
Copyright © 2022, Texas Instruments Incorporated

## Looking for pricing, stock, or lifecycle information?

Click below to explore more details on WIN SOURCE:

 [View UCC5870QEVM-045](#) on WIN SOURCE

 [Texas Instruments](#) Information

## Optimize Your Supply Chain with WIN SOURCE Solutions

-  Global Sourcing Solution
-  Obsolete Management
-  Cost Control Management
-  Shortage Management
-  Alternative Solution
-  Excess Inventory Management