



THE DATASHEET OF EK-LM4F120XL



Stellaris[®] LM4F120 LaunchPad Evaluation Kit

BoosterPack Development Guide



Build your own BoosterPack and take advantage of Texas Instruments' web site to help promote it!

From sharing a new idea or project, to designing, manufacturing, and selling your own BoosterPack kit, TI offers a variety of avenues for you to reach potential customers with your solutions.

www.ti.com/stellaris-launchpad

Copyright

Copyright © 2012 Texas Instruments, Inc. All rights reserved. Stellaris and StellarisWare are registered trademarks of Texas Instruments. ARM and Thumb are registered trademarks, and Cortex is a trademark of ARM Limited. Other names and brands may be claimed as the property of others.

Texas Instruments
108 Wild Basin, Suite 350
Austin, TX 78746
<http://www.ti.com/stellaris>



Table of Contents

Chapter 1: Stellaris® LaunchPad and BoosterPack Expansion Concept and Overview	6
BoosterPack Functional Interface.....	7
BoosterPack XL Functional Interface	9
LaunchPad Power Interface	10
Special Consideration for Shared Pins	11
Stellaris LaunchPad Dimensions and Mating	11
BoosterPack Design Guidelines	12
Appendix A: Schematics	13
Appendix B: References	17

List of Figures

Figure 1-1. Stellaris® LM4F120 LaunchPad Evaluation Board 7

List of Tables

Table 1-1. LaunchPad BoosterPack Compatibility Summary	6
Table 1-2. J1Connector	8
Table 1-3. J2 Connector	8
Table 1-4. J3 Connector	9
Table 1-5. J4 Connector	9
Table 1-6. Stellaris® LaunchPad Jumper List	11

Stellaris® LaunchPad and BoosterPack Expansion Concept and Overview

The Texas Instruments' Stellaris® LM4F120 LaunchPad concept is an extremely low-cost, expandable evaluation system for TI microcontrollers. This concept began with the tremendously successful MSP430™ LaunchPad which introduced a large number of engineers to the TI MSP430 family of microcontrollers. The TI Stellaris microcontroller family is expanding on that success by introducing the Stellaris® LM4F120 LaunchPad featuring the Stellaris ARM® Cortex™-M4F LM4F120H5QRF1G microcontroller.

A Stellaris LaunchPad consists of a target microcontroller, an in-circuit debug interface (ICDI) such as JTAG, a regulated power supply, a minimal microcontroller support circuit, a user interface, and a set of expansion headers. The expansion headers are referred to as the BoosterPack interface. A BoosterPack is an expansion card designed for this interface. This interface provides a mechanism for developers to easily extend the Stellaris LaunchPad with application- and user-specific functions.

The Stellaris LaunchPad provides a BoosterPack interface that is compatible with the MSP430 LaunchPad. In addition, the Stellaris LaunchPad provides access to additional Stellaris functionality through an extended BoosterPack interface called the BoosterPack XL Interface. BoosterPack interfaces with highly similar functionality for expansion will be available for the Stellaris LaunchPad, in addition to microcontroller-family-specific functionality available on a BoosterPack XL Interface for additional options. Table 1-1 provides a summary of BoosterPack interface compatibility.

Table 1-1. LaunchPad BoosterPack Compatibility Summary

LaunchPad	Compatible with...	
	BoosterPack Interface	BoosterPack XL Interface
Stellaris LaunchPad	Yes	Yes
MSP430 LaunchPad	Yes	No
Other TI LaunchPads	Yes	No

This development guide provides necessary design information for developers who want to create BoosterPacks that extend the functionality of the Stellaris® LaunchPad using either the original BoosterPack or the BoosterPack XL Interface. Figure 1-1 on page 7 shows a photo of the Stellaris® LaunchPad.

Figure 1-1. Stellaris® LM4F120 LaunchPad Evaluation Board

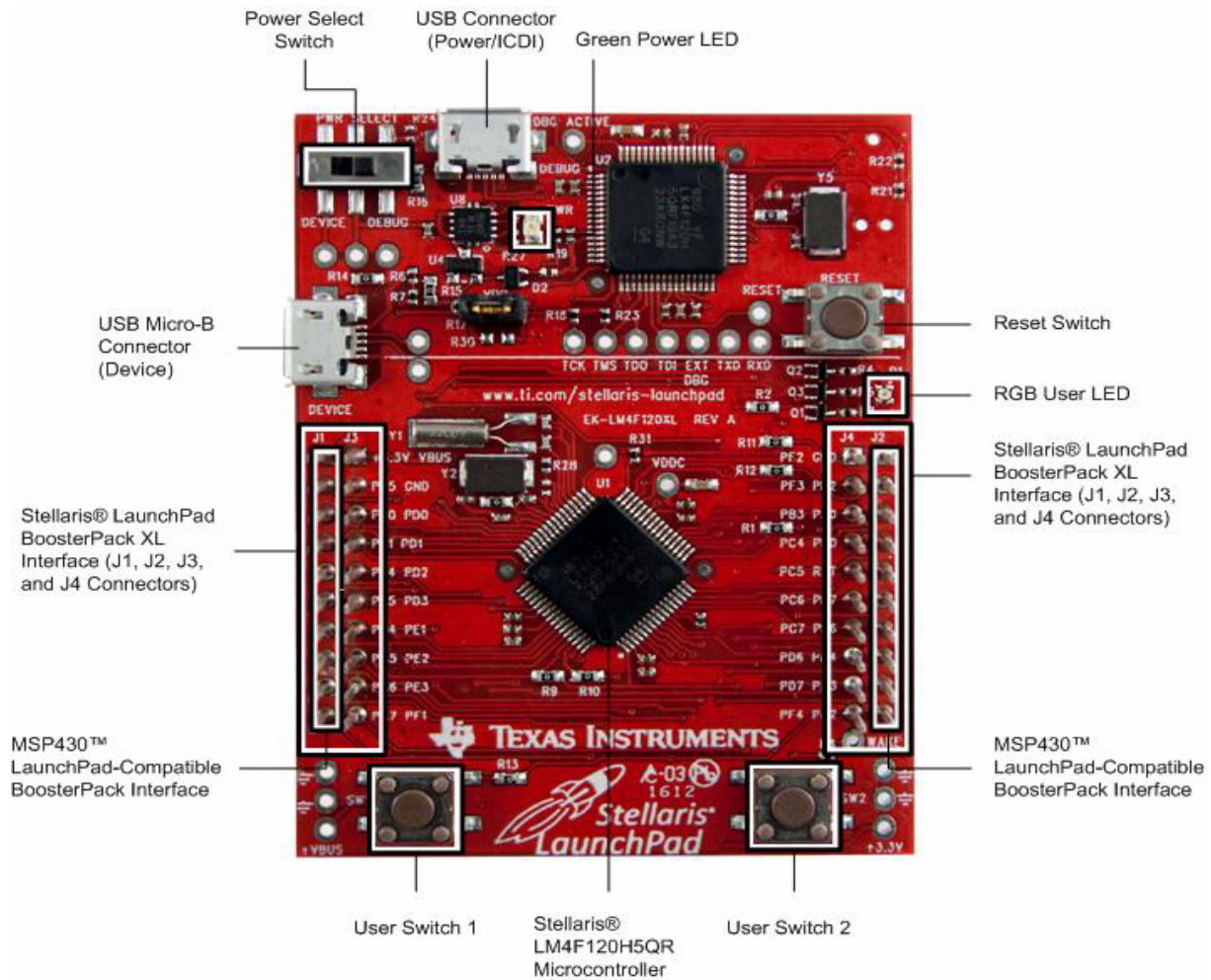

BoosterPack Functional Interface

The Stellaris® LaunchPad's BoosterPack Interface provides compatibility with the original MSP430 LaunchPad's BoosterPack interface. This interface consists of the outer 10 pin headers. The pins are spaced 0.10-inch apart with the two headers located 1.8 inches apart.

Table 1-2, "J1Connector" on page 8 and Table 1-3, "J2 Connector" on page 8 provide information for which Stellaris microcontroller peripherals are routed to each of the interface pins. The J1 connector is located on the far left side of the Stellaris LaunchPad. The J2 connector is located on the far right side of the Stellaris LaunchPad. Software is used to configure the LM4F120 pin for one of the functions found in the table. Highlighted functions indicate configuration for compatibility with the MSP430 LaunchPad.

Table 1-2. J1Connector

J1 Pin	GPIO	Stellaris Pin	GPIOCTL Register Setting							
			GPIOAMSEL	1	2	3	7	8	9	14
1.01	3.3 V									
1.02	PB5	57	AIN11	-	SSI2Fss	-	T1CCP1	CAN0Tx	-	-
1.03	PB0	45	-	U1Rx	-	-	T2CCP0	-	-	-
1.04	PB1	46	-	U1Tx	-	-	T2CCP1	-	-	-
1.05	PE4	59	AIN9	U5Rx	-	I2C2SCL	-	CAN0Rx	-	-
1.06	PE5	60	AIN8	U5Tx	-	I2C2SDA	-	CAN0Tx	-	-
1.07	PB4	58	AIN10	-	SSI2Clk	-	T1CCP0	CAN0Rx	-	-
1.08	PA5	22	-	-	SSI0Tx	-	-	-	-	-
1.09	PA6	23	-	-	-	I2C1SCL	-	-	-	-
1.10	PA7	24	-	-	-	I2C1SDA	-	-	-	-

Table 1-3. J2 Connector

J2 Pin	GPIO	Stellaris Pin	GPIOCTL Register Setting							
			GPIOAMSEL	1	2	3	7	8	9	14
2.01	GND									
2.02	PB2	47	-	-	-	I2C0SCL	T3CCP0	-	-	-
2.03	PE0	9	AIN3	U7Rx	-	-	-	-	-	-
2.04 ^a	PF0	28	-	U1RTS	SSI1Rx	CAN0Rx	T0CCP0	NMI	C0o	-
2.05	RESET									
2.06 ^b	PB7	4	-	-	SSI2Tx	-	T0CCP1	-	-	-
2.07 ^c	PB6	1	-	-	SSI2Rx	-	T0CCP0	-	-	-
2.08	PA4	21	-	-	SSI0Rx	-	-	-	-	-
2.09	PA3	20	-	-	SSI0Fss	-	-	-	-	-
2.10	PA2	19	-	-	SSI0Clk	-	-	-	-	-

- a. Not recommended for BoosterPack use. J2.04 is a TEST pin on the MSP430 LaunchPad. This signal tied to on-board function via 0-Ω resistor.
- b. J2.06 (PB7) is also connected via 0-Ω resistor to J3.04 (PD1) to provide MSP430 LaunchPad Compatible I2C SDA Signal.
- c. J2.07 (PB6) is also connected via 0-Ω resistor to J3.03 (PD0) to provide MSP430 LaunchPad Compatible I2C SCL Signal

BoosterPack XL Functional Interface

The BoosterPack XL Interface consists of the J1 and J2 connectors as well as the inner 10-pin headers spaced 1.6 inches apart directly inside of the MSP430 LaunchPad-compatible BoosterPack interface headers. The pins are spaced on 0.10-inch centers. These inner 10-pin headers (connectors J3 and J4) are not intended to be compatible with other TI LaunchPads or LaunchPad XL's. This is a Stellaris-only interface. TI recommends that LaunchPads provide analog functions on the left side of the BoosterPack XL interface and timer or PWM functions on the right side of the BoosterPack XL interface. Stellaris conforms to these recommendations. No effort has been made to make this interface compatible with any other LaunchPad.

Table 1-4 and Table 1-5 show which Stellaris peripherals are routed to each pin of the Stellaris-only BoosterPack XL Interface pins. J3 is the inner left BoosterPack XL Interface header. J4 is the inner right BoosterPack XL Interface header. Software is used to configure the LMF4120 pin for one of the functions found in the table.

Table 1-4. J3 Connector

J3 Pin	GPIO	Stellaris Pin	GPIOCTL Register Setting							
			GPIOAMSEL	1	2	3	7	8	9	14
3.01	5.0V									
3.02	GND									
3.03	PD0	61	AIN7	SSI3Clk	SSI1Clk	I2C3SCL	WT2CCP0	-	-	-
3.04	PD1	62	AIN6	SSI3Fss	SSI1Fss	I2C3SDA	WT2CCP1	-	-	-
3.05	PD2	63	AIN5	SSI3Rx	SSI1Rx	-	WT3CCP0	-	-	-
3.06	PD3	64	AIN4	SSI3Tx	SSI1Tx	-	WT3CCP1	-	-	-
3.07	PE1	8	AIN2	U7Tx	-	-	-	-	-	-
3.08	PE2	7	AIN1	-	-	-	-	-	-	-
3.09	PE3	6	AIN0	-	-	-	-	-	-	-
3.10 ^a	PF1	29	-	U1CTS	SSI1Tx	-	T0CCP1	-	C1o	TRD1

a. Not recommended for BoosterPack use. This signal tied to on-board function via 0-Ω resistor.

Table 1-5. J4 Connector

J4 Pin	GPIO	Stellaris Pin	GPIOCTL Register Setting							
			GPIOAMSEL	1	2	3	7	8	9	14
4.01 ^a	PF2	30	-	-	SSI1Clk	-	T1CCP0	-	-	TRD0
4.02 ^a	PF3	31	-	-	SSI1Fss	CAN0Tx	T1CCP1	-	-	TRCLK
4.03	PB3	48	-	-	-	I2C0SDA	T3CCP1	-	-	-
4.04	PC4	16	C1-	U4Rx	U1Rx	-	WT0CCP0	U1RTS	-	-
4.05	PC5	15	C1+	U4Tx	U1Tx	-	WT0CCP1	U1CTS	-	-
4.06	PC6	14	C0+	U3Rx	-	-	WT1CCP0	-	-	-

Table 1-5. J4 Connector (Continued)

J4 Pin	GPIO	Stellaris Pin	GPIOCTL Register Setting							
			GPIOAMSEL	1	2	3	7	8	9	14
4.07	PC7	13	C0-	U3Tx	-	-	WT1CCP1	-	-	-
4.08	PD6	53	-	U2Rx	-	-	WT5CCP0	-	-	-
4.09	PD7	10	-	U2Tx	-	-	WT5CCP1	NMI	-	-
4.10 ^a	PF4	5	-	-	-	-	T2CCP0	-	-	-

a. Not recommended for BoosterPack use. This signal tied to on-board function via 0-Ω resistor.

LaunchPad Power Interface

The Stellaris LaunchPad has provisions to provide power to a BoosterPack through either the BoosterPack interface or the BoosterPack XL Interface. The configuration of power and ground pins on both of these interfaces must be consistent across LaunchPads from all TI microcontroller families.

The Stellaris LaunchPad draws power from either of the on-board USB interfaces as selected by the power switch in the top left corner of the board. Typically, the USB connection provides 500 milliamps at 5 V to the Stellaris LaunchPad. The selected USB power source is made directly available to the BoosterPack XL Interface on the J3.01 pin. This is a direct connection with only small decoupling capacitors provided on the Stellaris LaunchPad.

All LaunchPads, including the Stellaris LaunchPad, also provide a 3.3-V supply on pin J1.01 of the BoosterPack interface. On the Stellaris LaunchPad, this is sourced by a TPS73633 LDO voltage regulator which converts the selected 5-V USB power to 3.3 V. The regulator is capable of sourcing 400 milliamps at 3.3 V. This 3.3-V supply is shared between the BoosterPack interface, the in-circuit debug interface (ICDI), and the target microcontroller. Therefore, under normal circumstances, about 300 to 350 milliamps are available to the BoosterPack interface. Detailed power management is left to the BoosterPack developer who must also manage the application to be run on the target microcontroller.

The Stellaris LaunchPad can be powered through an external supply on a BoosterPack. If providing power to the Stellaris LaunchPad from a BoosterPack, move the power select switch to select an unused USB connection to prevent power bus contention between the BoosterPack and the USB connection. Power may be supplied to either the 3.3 V or the 5.0-V system but not both. Providing external power to both 5 V and 3.3 V would result in a contention between the external power supplies and the Stellaris LaunchPad's voltage regulator. Providing only 3.3 V will result in some lost functionality such as the on-board LED's. It may also result in reverse current leakage through the on-board voltage regulator. Therefore, it is recommended if providing power externally to use either the existing USB connections or an external 5-V supply from a BoosterPack.

Ground connections are available on pins J2.01 and J3.02. These provide a ground connection for both the BoosterPack interface and the BoosterPack XL Interface respectively.

Additional power and ground pins are available through labeled pins located in the extreme lower corners of the Stellaris LaunchPad. These are connected to the same 3.3 V, 5 V, and ground connections as the pins on the BoosterPack interface and the BoosterPack XL Interface.

Special Consideration for Shared Pins

To provide compatibility with the MSP430 LaunchPad's BoosterPack interface and to provide a maximum number of signals to the BoosterPack interface and BoosterPack XL Interface, it was necessary to route some signals to more than one pin. In addition, certain on-board functions such as the button and LED signals are available on the BoosterPack interface and BoosterPack XL Interface. A 0- Ω jumper resistor was installed for signals that are used for more than one purpose or routed to more than one GPIO. Removal of this jumper disconnects the functions. All jumpers are installed by default. A listing of these jumpers and their use is provided in Table 1-6.

Table 1-6. Stellaris® LaunchPad Jumper List

Resistor	Primary Function	Alternate Function	Comments
R1	Right User Switch	J2.04	Test pin on MSP430 LaunchPad. This connection along with R13 provides Hibernate wake to BoosterPack interface
R2	Red LED	To PF1 and J3.10	If removed: allows extra GPIO to the BoosterPack XL interface. If installed (default): allows booster pack to drive LED or sense LED state. Also provides Embedded Trace signal TRD1.
R8	Hibernate Wake	To PF0 and J2.04 via R1	Allows user switch 2 to wake device from hibernate. Also ties wake to J2.04 to allow BoosterPack to wake Stellaris LaunchPad from Hibernate.
R9	PB6 SSI2 TX on J2.07	PD0 I2C SCL on J2.07	Routes I2C from PD0 to J2.07 for MSP430 Stellaris LaunchPad compatibility. If using PD0 or PB6, the unused GPIO must be configured as an input or R9 removed.
R10	PB7 SSI2 RX on J2.06	PD1 I2C SDA on J2.06	Routes I2C from PD1 to J2.06 for MSP430 Stellaris LaunchPad compatibility. If using PD1 or PB7, the unused GPIO must be configured as an input or R9 removed.
R11	Blue LED	To PF2 and J4.01	If removed: allows extra GPIO to the BoosterPack XL interface. If installed (default): allows BoosterPack to drive LED or sense LED state. Also provides Embedded Trace signal TRD0.
R12	Green LED	To PF3 and J4.02	If removed: allows extra GPIO to the BoosterPack XL interface. If installed (default): allows BoosterPack to drive LED or sense LED state. Also provides Embedded Trace signal TRDCLK.
R13	Left User Switch	To PF4 and J4.10	If removed: allows extra GPIO to the BoosterPack XL interface. If installed (default): allows BoosterPack to simulate switch press or sense switch state.

Stellaris LaunchPad Dimensions and Mating

Figure 1-1 on page 7 shows a dimensional drawing of the Stellaris LaunchPad. J1 and J2 are 1.8 inches apart and constitute the BoosterPack interface. J3 and J4 are 1.6 inches apart and constitute the BoosterPack XL Interface. Other major board signals are available on unpopulated headers on a 0.1 inch grid. Dimensions to these signals are provided for convenience. These signals are subject to change or move across revisions of the Stellaris LaunchPad or future LaunchPads. It is recommended that BoosterPacks use only the BoosterPack interface and BoosterPack XL Interface. Use of other pins and signals is acceptable but these pins and signals can change at any time.

BoosterPack Design Guidelines

Follow these guidelines when designing your BoosterPack:

- BoosterPacks should not extend more than 0.350 inches above the center of the top BoosterPack interface pin.
- BoosterPacks should not extend more than 0.150 inches below the center of the bottom pin of the BoosterPack interface.

Note: BoosterPacks that extend more than 0.150 inches below the center of the bottom pin will partially cover the Stellaris LaunchPad user switches which can result in lost user access to those user inputs.

- BoosterPacks are not restricted in width and may extend as much as desired left and right of the Stellaris LaunchPad.
- For BoosterPacks with RF antennas, place the antenna to the left or right of the Stellaris LaunchPad for minimal interference and signal attenuation.
- The BoosterPack interface does not provide any means of keying or alignment guidance. It is recommended that visual cues be provided on the BoosterPack to assist user in proper orientation of the BoosterPack.
- If possible, design the BoosterPack so that incorrect mating to a Stellaris LaunchPad will not damage the BoosterPack.

Schematics

This section contains the schematics for the Stellaris® LaunchPad evaluation board:

- Microcontroller, USB, Expansion, Buttons, and LED on page 14
- Power Management on page 15
- Stellaris In-Circuit Debug Interface (ICDI) on page 16

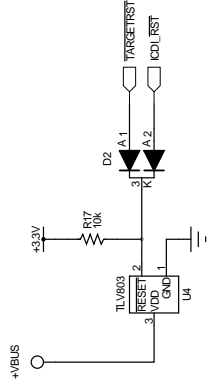
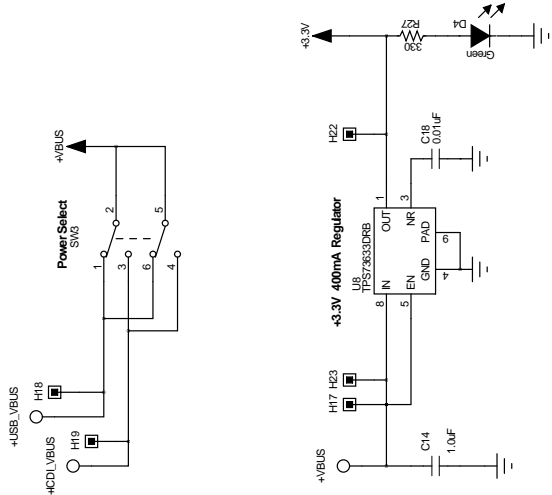
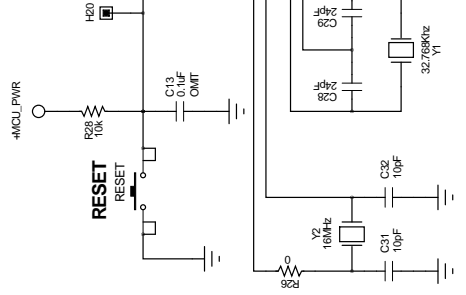

DESIGNER	REVISION	DATE
DGT	0.1	8/23/2012
PROJECT		
Stellaris Launchpad		
DESCRIPTION		
Power Management		
FILENAME		
EK-LM4F120XL_RevA.sch		

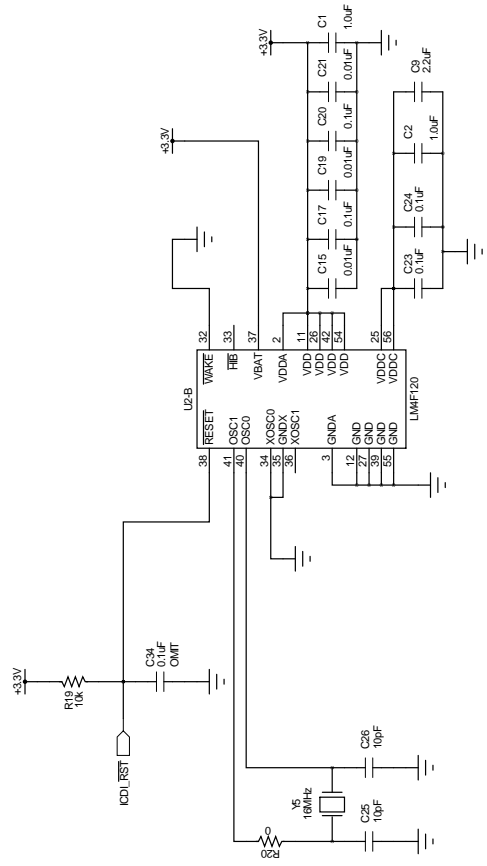
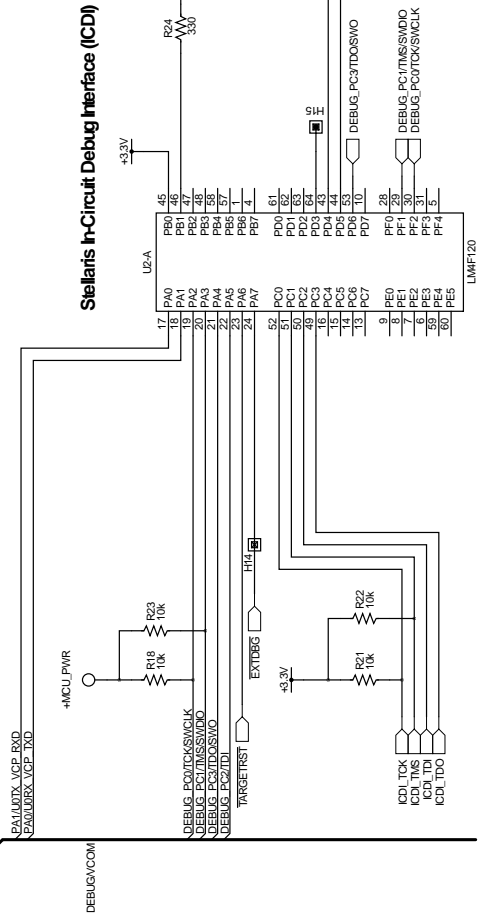

DESIGNER	REVISION	DATE
DGT	0.1	8/23/2012
PROJECT		
Stellaris Launchpad		
DESCRIPTION		
SSStellaris In Circuit Debug Interface		
FILENAME		
EK-LM4F120XL RevA.sch		

References

In addition to this document, the following references are included on the Stellaris LaunchPad Evaluation Kit CD and are also available for download at www.ti.com.

- *Stellaris LaunchPad (EK-LM4120XL) User's Manual*, publication EK-LM4F120-XL
- *Stellaris LM4F120H5QRFIG Microcontroller Data Sheet*, publication DS-LM4F120H5QR
- StellarisWare® Driver Library
- *StellarisWare® Driver Library User's Manual*, publication SW-DRL-UG

Information on development tool being used:

- Texas Instruments' Code Composer Studio™ IDE web site, www.ti.com/ccs

IMPORTANT NOTICE

Texas Instruments Incorporated and its subsidiaries (TI) reserve the right to make corrections, enhancements, improvements and other changes to its semiconductor products and services per JESD46C and to discontinue any product or service per JESD48B. Buyers should obtain the latest relevant information before placing orders and should verify that such information is current and complete. All semiconductor products (also referred to herein as "components") are sold subject to TI's terms and conditions of sale supplied at the time of order acknowledgment.

TI warrants performance of its components to the specifications applicable at the time of sale, in accordance with the warranty in TI's terms and conditions of sale of semiconductor products. Testing and other quality control techniques are used to the extent TI deems necessary to support this warranty. Except where mandated by applicable law, testing of all parameters of each component is not necessarily performed.

TI assumes no liability for applications assistance or the design of Buyers' products. Buyers are responsible for their products and applications using TI components. To minimize the risks associated with Buyers' products and applications, Buyers should provide adequate design and operating safeguards.

TI does not warrant or represent that any license, either express or implied, is granted under any patent right, copyright, mask work right, or other intellectual property right relating to any combination, machine, or process in which TI components or services are used. Information published by TI regarding third-party products or services does not constitute a license to use such products or services or a warranty or endorsement thereof. Use of such information may require a license from a third party under the patents or other intellectual property of the third party, or a license from TI under the patents or other intellectual property of TI.

Reproduction of significant portions of TI information in TI data books or data sheets is permissible only if reproduction is without alteration and is accompanied by all associated warranties, conditions, limitations, and notices. TI is not responsible or liable for such altered documentation. Information of third parties may be subject to additional restrictions.

Resale of TI components or services with statements different from or beyond the parameters stated by TI for that component or service voids all express and any implied warranties for the associated TI component or service and is an unfair and deceptive business practice. TI is not responsible or liable for any such statements.

Buyer acknowledges and agrees that it is solely responsible for compliance with all legal, regulatory and safety-related requirements concerning its products, and any use of TI components in its applications, notwithstanding any applications-related information or support that may be provided by TI. Buyer represents and agrees that it has all the necessary expertise to create and implement safeguards which anticipate dangerous consequences of failures, monitor failures and their consequences, lessen the likelihood of failures that might cause harm and take appropriate remedial actions. Buyer will fully indemnify TI and its representatives against any damages arising out of the use of any TI components in safety-critical applications.

In some cases, TI components may be promoted specifically to facilitate safety-related applications. With such components, TI's goal is to help enable customers to design and create their own end-product solutions that meet applicable functional safety standards and requirements. Nonetheless, such components are subject to these terms.

No TI components are authorized for use in FDA Class III (or similar life-critical medical equipment) unless authorized officers of the parties have executed a special agreement specifically governing such use.

Only those TI components which TI has specifically designated as military grade or "enhanced plastic" are designed and intended for use in military/aerospace applications or environments. Buyer acknowledges and agrees that any military or aerospace use of TI components which have **not** been so designated is solely at the Buyer's risk, and that Buyer is solely responsible for compliance with all legal and regulatory requirements in connection with such use.

TI has specifically designated certain components which meet ISO/TS16949 requirements, mainly for automotive use. Components which have not been so designated are neither designed nor intended for automotive use; and TI will not be responsible for any failure of such components to meet such requirements.

Products

Audio	www.ti.com/audio
Amplifiers	amplifier.ti.com
Data Converters	dataconverter.ti.com
DLP® Products	www.dlp.com
DSP	dsp.ti.com
Clocks and Timers	www.ti.com/clocks
Interface	interface.ti.com
Logic	logic.ti.com
Power Mgmt	power.ti.com
Microcontrollers	microcontroller.ti.com
RFID	www.ti-rfid.com
OMAP Mobile Processors	www.ti.com/omap
Wireless Connectivity	www.ti.com/wirelessconnectivity

Applications

Automotive and Transportation	www.ti.com/automotive
Communications and Telecom	www.ti.com/communications
Computers and Peripherals	www.ti.com/computers
Consumer Electronics	www.ti.com/consumer-apps
Energy and Lighting	www.ti.com/energy
Industrial	www.ti.com/industrial
Medical	www.ti.com/medical
Security	www.ti.com/security
Space, Avionics and Defense	www.ti.com/space-avionics-defense
Video and Imaging	www.ti.com/video

TI E2E Community e2e.ti.com

Looking for pricing, stock, or lifecycle information?

Click below to explore more details on WIN SOURCE:

 [View EK-LM4F120XL on WIN SOURCE](#)

 [Texas Instruments](#) Information

Optimize Your Supply Chain with WIN SOURCE Solutions

-  Global Sourcing Solution
-  Obsolete Management
-  Cost Control Management
-  Shortage Management
-  Alternative Solution
-  Excess Inventory Management