



**THE DATASHEET OF  
DH1364-470M**



Series Number  
 DH8950  
 DH1364  
 DH2280



3004 9th Av 3005 9th Avenue SW  
 Watertown, Watertown, SD 57203  
 Toll free: 88 Toll free: 888-978-2640  
 Ph: 605-88 Ph: 605-886-3328  
 Fax: 605-88 Fax: 605-886-8997



**SMD Unshielded Self-Leaded Inductor ; Part Numbering Sequence: ( Series Number ) - ( Suffix Code )(Tolerance), example DH1364-100M**  
**Bulk Packaging add (-B) to end of Part Numbering Sequence. example DH1364-100M-B**

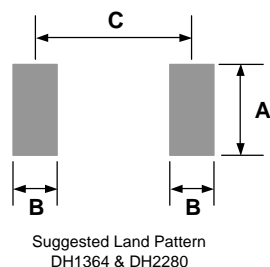
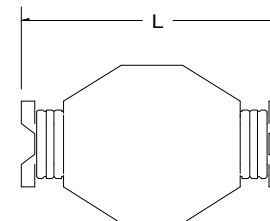
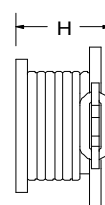
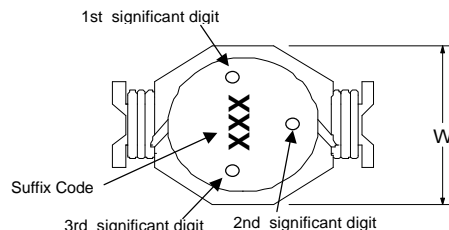
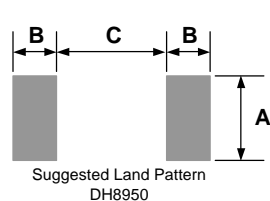

Parts will be marked with Significant Digit Dots OR Suffix code

Series Number	Units	Maximum Dimensions			Nominal Dimensions		
		L	W	H	A	B	C
DH8950	inches	0.362"	0.252"	0.197"	0.160"	0.075"	0.200"
	[ mm ]	[ 9.19 ]	[ 6.40 ]	[ 5.00 ]	[ 4.06 ]	[ 1.91 ]	[ 5.08 ]
DH1364	inches	0.522"	0.392"	0.250"	0.160"	0.060"	0.400"
	[ mm ]	[ 13.26 ]	[ 9.96 ]	[ 6.35 ]	[ 4.06 ]	[ 1.52 ]	[ 10.16 ]
DH2280	inches	0.880"	0.640"	0.315"	0.340"	0.125"	0.690"
	[ mm ]	[ 22.35 ]	[ 16.26 ]	[ 8.00 ]	[ 8.64 ]	[ 3.18 ]	[ 17.53 ]

**Features:**

- High energy storage and low resistance
- Ideal for DC-DC step-up or step-down conversion
- Reliable surface mounting, flat top for pick and place
- Robust temperature deflection to prevent

L <sup>1</sup> μH	Suffix Codes	DH8950				DH1364				DH2280				Significant Digit Dot Code		
		DCR <sup>2</sup> W	I <sub>SAT</sub> <sup>4</sup> A	I <sub>RMS</sub> <sup>5</sup>	Tolerance Suffix <sup>6</sup>	DCR <sup>2</sup> W	I <sub>SAT</sub> <sup>3</sup> A	I <sub>RMS</sub> <sup>5</sup>	Tolerance Suffix <sup>6</sup>	DCR <sup>2</sup> W	I <sub>SAT</sub> <sup>3</sup> A	I <sub>RMS</sub> <sup>5</sup>	Tolerance Suffix <sup>6</sup>	1st	2nd	3rd
0.33	R33					0.002	20.0	16.0	M					Orange	Orange	Brown
0.56	R56	0.010	7.7	6.00	M									Green	Blue	Brown
0.68	R68					0.005	13.0	12.0	M					Blue	Grey	Brown
0.78	R78									0.0026	30.0	15.0	M	Violet	Grey	Brown
1.0	1R0					0.006	11.0	10.0	M					Brown	Black	Red
1.2	1R2	0.017	5.3	4.40	M									Brown	Red	Red
1.5	1R5					0.008	9.0	9.0	M	0.0040	25.0	15.0	M	Brown	Green	Red
2.2	2R2	0.035	3.5	3.10	M	0.011	7.8	7.4	M	0.0061	20.0	12.0	M	Red	Red	Red
2.7	2R7					0.012	7.0	6.6	M					Red	Violet	Red
3.3	3R3					0.014	6.4	5.9	M	0.0086	17.0	10.0	M	Orange	Orange	Red
3.9	3R9									0.0100	15.0	9.0	M	Orange	White	Red
4.7	4R7	0.054	2.6	2.20	M	0.018	5.4	4.8	M	0.0140	13.0	8.4	M	Yellow	Violet	Red
6.0	6R0									0.0170	12.0	7.5	M	Blue	Black	Red
6.8	6R8					0.035	3.6	4.5	M					Blue	Grey	Red
7.8	7R8									0.0180	11.0	7.5	M	Violet	Grey	Red
10	100	0.111	1.9	1.50	M	0.040	3.30	4.50	M	0.0260	10.0	6.0	M	Brown	Black	Orange
15	150	0.170	1.5	1.20	M	0.060	2.40	3.50	M	0.0320	8.0	4.4	M	Brown	Green	Orange
22	220	0.250	1.20	1.00	M	0.080	2.00	2.80	M					Red	Red	Orange
33	330	0.370	0.99	0.82	M	0.150	1.70	2.10	M					Orange	Orange	Orange
47	470	0.470	0.87	0.72	M	0.280	1.40	1.70	M					Yellow	Violet	Orange
68	680					0.300	1.20	1.50	M					Blue	Grey	Orange
100	101					0.400	0.95	1.2	M					Brown	Black	Yellow

1) Tolerance ±20%, Tested at 100kHz, 100mVrms @20°C. DH8950 series tested at 100kHz, 250mVrms @20°C.  
 2) DCRs (DC resistances) are maximums @20°C.  
 3) DC (Direct Current) current applied to produce a typical 10% drop from measured nominal inductance.  
 4) DC (Direct Current) current applied to produce a typical 30% drop from measured nominal inductance.  
 5) Current applied to produce a typical 40°C temperature rise from measured nominal inductance.  
 6) Tolerance M = ±20%

Specifications subject to change without notice

Call Toll Free: 888-978-2638 Website: www.coev.net

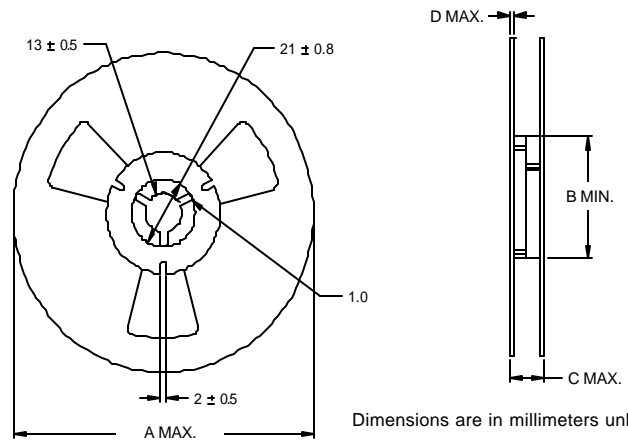

Dimensions are in millimeters unless specified.

Series Number	Reel dimensions				Reel Qty	Packaging Specification	
	Units	A	B	C			D
DH8950	in.	(B) 14.17"	(B) 3.94"	0.882"	(B) 0.098"	1000	90-0061
	[mm]	[ 360 ]	[ 100.0 ]	[ 22.4 ]	[ 2.50 ]		
DH1364	in.	(B) 14.17"	(B) 3.94"	(B) 1.20"	(B) 0.098"	750	90-0055
	[mm]	[ 360 ]	[ 100.0 ]	[ 30.4 ]	[ 2.50 ]		
DH2280	in.	(B) 14.17"	(B) 3.94"	(B) 1.98"	(B) 0.098"	250	90-0064
	[mm]	[ 360 ]	[ 100.0 ]	[ 50.4 ]	[ 2.50 ]		

PACKAGING NOTE: Only pressure sensitive cover tape is to be used.

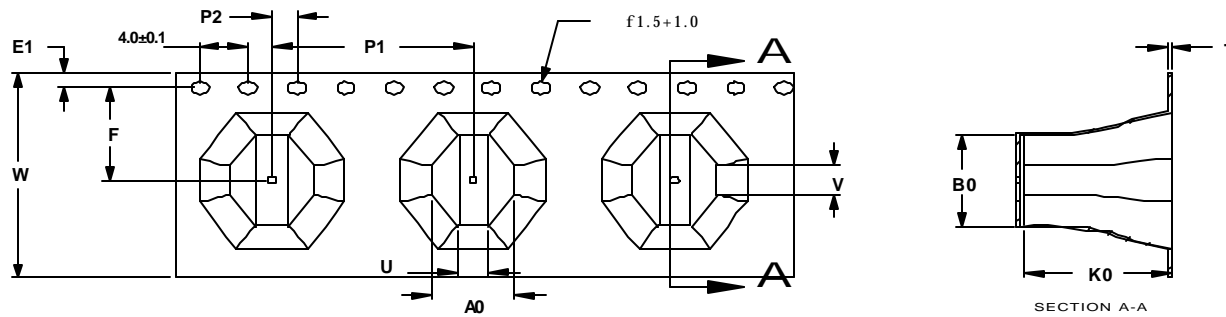

Series	A0 ± 0.1	U ± 0.1	V ± 0.1	P1 ± 0.1	P2 ± 0.1	W ± 0.3	F ± 0.1	E1 ± 0.1	B0 ± 0.1	K0 ± 0.05	T ± 0.05
DH8950	6.65	4.70	2.90	12.00	2.00	16.00	7.50	1.75	9.45	4.70	0.35
DH1364	10.30	5.80	4.00	16.00	2.00	24.00	11.50	1.75	13.50	5.70	0.35
DH2280	15.40	8.10	5.30	24.00	2.00	44.00	20.20	1.75	22.50	6.90	0.35

**Customer Packaging Specifications**  
For Print Distribution to Customers

Series	Revision
<b>DH SERIES</b>	<b>B</b>

Item	Specification	Test Method/Condition
<b>Environmental</b>		
Static Humidity	After exposure part remains within specified electrical parameters for L, Q and DCR.	Precondition at 25°C for 60 minutes. Expose parts to an environment of +40°C with 90 to 95% R.H. for 240 hours.
Storage Life	After exposure part remains within specified electrical parameters for L, Q and DCR.	Subject parts to an environment of 85°C 85% R.H. for 168 hours. After exposure allow parts to dry for 4 hours before measurements are taken.
Temperature Cycle	After exposure part remains within specified electrical parameters for L, Q and DCR.	10 cycles (Air to Air) 1 cycle shall consist of: 30 minutes exposure to +85°C 30 minutes exposure to -40°C Allow 20 minutes transition between extremes.
Temperature Shock	After exposure part remains within specified electrical parameters for L, Q and DCR.	10 cycles (Air to Air) 1 cycle shall consist of: 30 minutes exposure to -55°C 30 minutes exposure to +125°C 15 seconds maximum transition between temperatures
<b>General</b>		
Storage Temperature Range	-40°C to +85°C	
Operating Temperature Range	-40°C to +85°C	
Flammability	IEC 695-2-2	Withstands needle-flame test
<b>Other</b>		
Vibration	After exposure part remains within specified electrical parameters for L, Q and DCR.	1 cycle of 30 minutes of the following: 5 - 7 Hz constant displacement of 0.75 inches, 5 minutes 7 - 30 Hz constant acceleration of 1.5 Gs, 10 minutes 31 - 50 Hz constant displacement of 0.33 inches, 5 minutes 50 - 500 Hz constant acceleration of 1.2 Gs, 10 minutes
Mechanical Shock	After exposure part remains within specified electrical parameters for L, Q and DCR.	DH8950 Series - 2000 Gs per axis, 2 directions DH1364 Series - 500 Gs per axis, 2 directions DH2280 Series - 500 Gs per axis, 2 directions
Solderability	Wetting shall cover 90% minimum of each termination	Dip pads in RMA flux, 63/37 solder (Sn/Pb) at 232°C for 5 seconds ±2 seconds.
Component Adhesion (Push Test)	Component shall withstand 6 lb. push force minimum without delaminating from mounting surface.	Apply and measure force with a digital force gauge set.
Resistance to Solvent		Withstands 6 minutes of alcohol.
		Withstands 3 minutes forced spray Freon TMS
<b>Chemical</b>		
Ionic Contamination	Conductivity: pH: Chlorides: Sodium: Potassium:	11 μOhms/cm maximum 5.5 to 9 65 ppm maximum 20 ppm maximum 10 ppm maximum
<b>For Print Distribution to Customers</b>		Series
		<b>DH SERIES</b>
		Revision
		<b>B</b>
Sheet 3 of 3		

## Looking for pricing, stock, or lifecycle information?

Click below to explore more details on WIN SOURCE:

 [View DH1364-470M on WIN SOURCE](#)

 [TE Connectivity](#) Information

## Optimize Your Supply Chain with WIN SOURCE Solutions

-  Global Sourcing Solution
-  Obsolete Management
-  Cost Control Management
-  Shortage Management
-  Alternative Solution
-  Excess Inventory Management