



**THE DATASHEET OF
MAAL-011141-TR0500**



Low Noise Amplifier

DC - 28 GHz



MAAL-011141

Rev. V4

Features

- Ultra Wideband Performance
- Noise Figure: 1.4 dB @ 8 GHz
- High Gain: 17.5 dB @ 8 GHz
- Output IP3: 27.5 dBm @ 8 GHz
- Bias Voltage: $V_{DD} = 5 - 6 V$
- Bias Current: $I_{DSQ} = 60 - 100 mA$
- 50 Ω Matched Input / Output
- Positive Voltage Only
- Lead-Free 5 mm 32-lead AQFN Package
- RoHS* Compliant

Applications

- Test & Measurement, EW, ECM, and Radar

Description

The MAAL-011141 is an easy to use, wideband low noise distributed amplifier die. It operates from DC to 28 GHz and provides 17.5 dB of linear gain, 16 dBm of P1dB and 1.4 dB of noise figure at 8 GHz. The input and output are fully matched to 50 Ω with typical return loss >15 dB.

This amplifier employs an active termination circuit to achieve a lower noise figure at the lower end of the frequency range than is possible using traditional resistive termination techniques.

This product is fabricated using a GaAs pHEMT process which features full passivation for enhanced reliability.

The MAAL-011141 can be used as a low noise amplifier stage or as a driver stage in higher power applications. This device is ideally suited for Test and Measurement, EW, ECM, and Radar applications.

Ordering Information^{1,2}

Part Number	Package
MAAL-011141-TR0500	500 piece reel
MAAL-011141-001SMB	Sample Board

1. Reference Application Note M513 for reel size information.
2. All sample boards include 3 loose parts.

* Restrictions on Hazardous Substances, compliant to current RoHS EU directive.

Functional Schematic

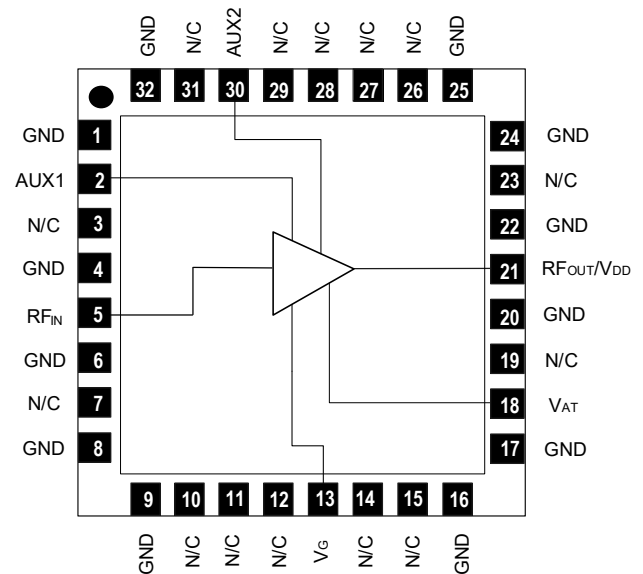

Pin Configuration^{3,4}

Pin #	Pin Name	Description
2	AUX1	Auxiliary Drain Voltage 1
5	RF _{IN}	RF Input
13	V _G	Gate Voltage
18	V _{AT}	Active Termination Voltage
21	RF _{OUT} / V _{DD}	RF Output / Drain Voltage
30	AUX2	Auxiliary Drain Voltage 2
1, 4, 6, 8, 9, 16, 17, 20, 22, 24, 25, 32	GND	Ground
3, 7, 10 - 12, 14, 15, 19, 23, 26 - 29, 31	N/C	No Connection

3. MACOM recommends connecting all no connection pins to ground.
4. The exposed pad centered on the package bottom must be connected to RF, DC and thermal ground.

Electrical Specifications: $T_A = +25^\circ\text{C}$, $V_{DD} = 6\text{ V}$, $I_{DSQ} = 75\text{ mA}$, $V_{AT} = 5\text{ V}$, $Z_0 = 50\ \Omega$

Parameter	Test Conditions	Units	Min.	Typ.	Max.
Gain	$P_{IN} = -20\text{ dBm}$ 2.0 GHz 8.0 GHz 12.0 GHz 18.0 GHz 26.5 GHz	dB	16.0 — 15.0 — —	18.0 17.5 17.5 17.5 17.5	—
Output P1dB	2.0 GHz 8.0 GHz 12.0 GHz 18.0 GHz 26.5 GHz	dBm	—	17.0 16.0 15.5 15.5 12.0	—
OIP3	$P_{IN} = -20\text{ dBm}$ / tone, 10 MHz Tone Spacing 2.0 GHz 8.0 GHz 12.0 GHz 18.0 GHz 26.5 GHz	dBm	—	29.5 27.5 26.0 25.0 22.5	—
Input Return Loss	$P_{IN} = -20\text{ dBm}$	dB	—	15	—
Output Return Loss	$P_{IN} = -20\text{ dBm}$	dB	—	15	—
Noise Figure	2.0 GHz 8.0 GHz 12.0 GHz 18.0 GHz 26.5 GHz	dB	—	2.7 1.4 1.5 2.2 3.4	3.5 — 2.2 — —
Isolation	$P_{IN} = -20\text{ dBm}$ 2.0 GHz 8.0 GHz 12.0 GHz 18.0 GHz 26.5 GHz	dB	—	55 40 37 35 33	—
V_G	Adjusted to set $I_{DSQ} = 75\text{ mA}$	V	—	0.7	—
I_{AT}	$V_{AT} = 5\text{ V}$	mA	—	10	—

Operating Conditions

Recommended biasing conditions are $V_{DD} = 6\text{ V}$, $I_{DSQ} = 75\text{ mA}$. Bias of 5 V must be applied to V_{AT} pin. I_{DSQ} is set by adjusting V_G after setting V_{DD} and V_{AT} . The drain bias voltage range, V_{DD} , is 5 to 6 V, and the quiescent drain current biasing is 60 to 100 mA. To maintain the best performance MACOM recommends using an active bias circuit for constant I_{DD} .

There are three possible bias methods:

1. The use of an external bias tee where the required V_{DD} is applied at RF_{OUT}/V_{DD} and V_G is set to provide a current bias (I_{DSQ}) of 60 to 100 mA. This provides wide band performance of DC - 28 GHz. (depending on the bandwidth of the bias tee).
2. The direct application of V_{DD} to AUX1. Using this method provides for an operational frequency of 2 - 28 GHz. However, a voltage drop across an internal 17 Ω resistance and a 1.5 Ω typical series DC inductor resistance must be accounted for. For example, with $I_{DSQ} = 75\text{ mA}$, 7.4 V must be applied at AUX1 for a V_{DD} of 6 V.
3. The direct application of V_{DD} to AUX2. Using this method provides for an operational frequency of DC - 28 GHz. However, a voltage drop across series 17 Ω and 32 Ω resistors must be accounted for. For example, with $I_{DSQ} = 75\text{ mA}$, 9.67 V must be applied at AUX2 for a V_{DD} of 6 V.

In all cases DC blocking is required on the RF input. Additionally options 2 and 3 require DC blocking on the RF output line. It should also be noted that when using the internal bias circuit (option 2 or 3) I_{DSQ} is limited to a maximum of 80 mA.

Regardless of bias method used, a bypass capacitor of 0.1 μF should be connected to AUX2. This provides for increased device stability margins and improved gain flatness below 2 GHz when required. When using bias method 2, an 82 nH series inductor combined with a 0.1 μF shunt capacitor and 220 Ω resistor is recommended. This increases gain flatness below 2 GHz.

The available evaluation board is configured for bias option 3 using AUX2 for the supply of V_{DD} .

Maximum Operating Conditions

Parameter	Operating Maximum
Input Power ⁵	$P_{IN} \leq 1\text{ dB compression level}$
Junction Temperature ⁶	+150°C
Operating Temperature	-40°C to +85°C

5. MACOM does not recommend sustained operation at power levels above 1 dB gain compression.
6. Operating at nominal conditions with junction temperature $\leq +150^\circ\text{C}$ will ensure MTTF $> 1 \times 10^6$ hours.

Absolute Maximum Ratings^{7,8}

Parameter	Absolute Maximum
Input Power	18 dBm
Drain Voltage	7 V
Gate Voltage	0.9 V
Active Termination Voltage	6 V
AUX1 Current	80 mA
AUX2 Current	80 mA
Junction Temperature ⁹	+175°C
Storage Temperature	-65°C to +125°C

7. Exceeding any one or combination of these limits may cause permanent damage to this device.
8. MACOM does not recommend sustained operation near these survivability limits.
9. Junction temperature directly effects device MTTF, and should be kept as low as possible to maximize product lifetime.

Handling Procedures

Please observe the following precautions to avoid damage:

Static Sensitivity

These electronic devices are sensitive to electrostatic discharge (ESD) and can be damaged by static electricity. Proper ESD control techniques should be used when handling these HBM Class 1A devices.

Application Schematic

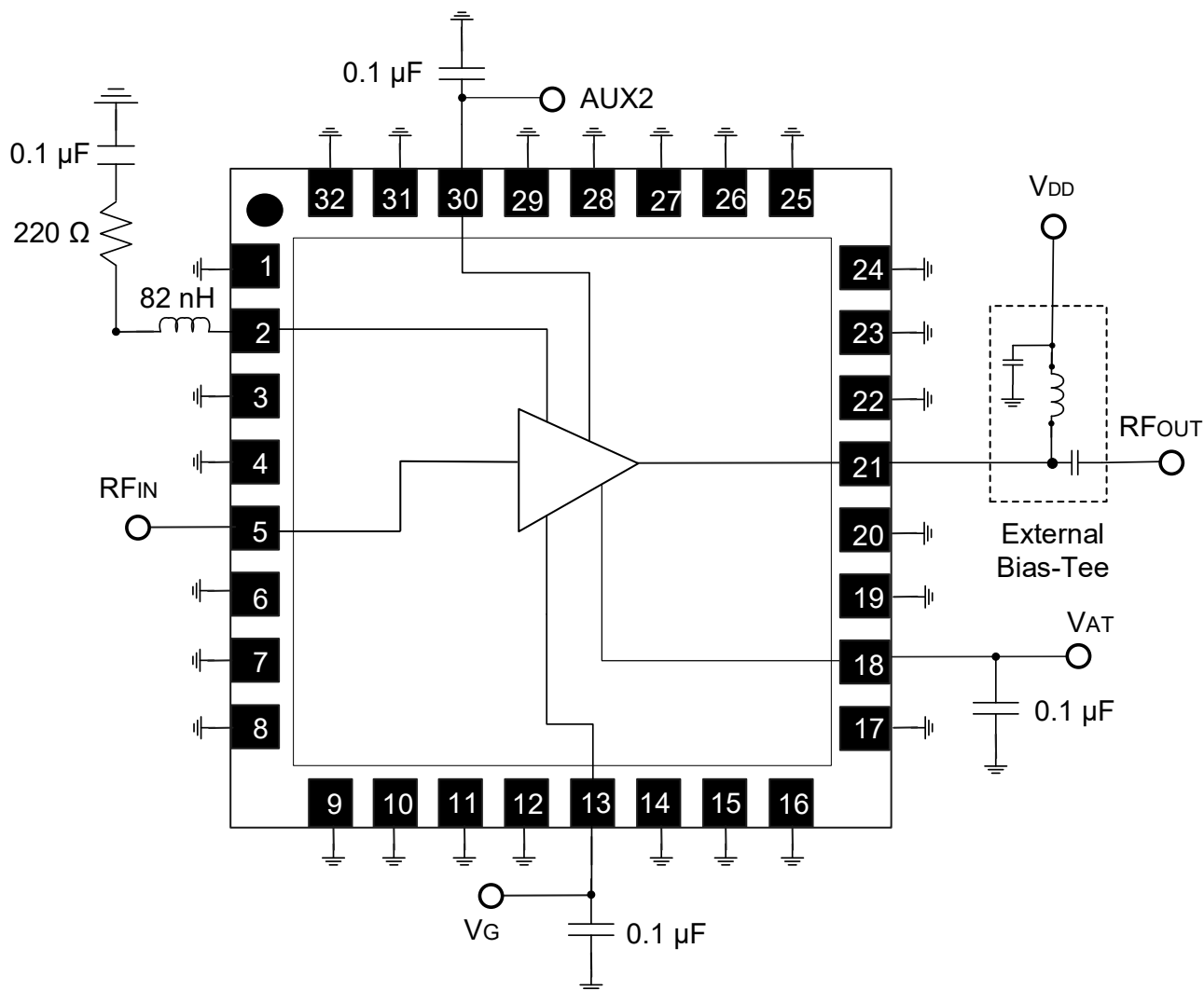

Applications Section: Sample board layout for bias option 3 using AUX2

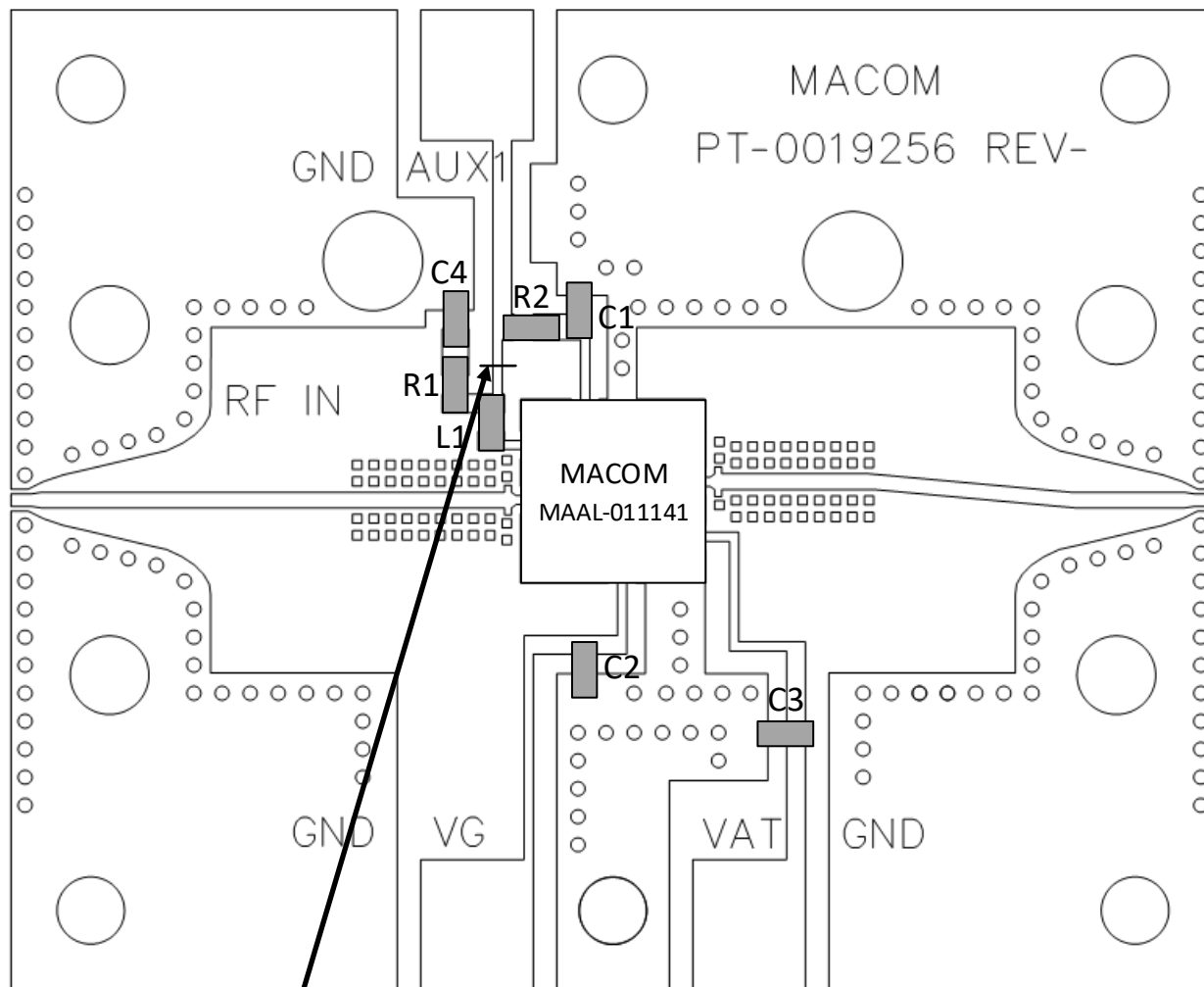

Cut trace for AUX2 operation

Parts List

Part	Value	Case Style
C1 - C4	0.1 μ F	0402
R1	220 Ω	0402
R2	0 Ω	0402
L1	82 nH	0402

Evaluation PCB Specifications

Top Layer: 1/2 oz Copper Cladding, 0.017 mm thickness
Dielectric Layer: Rogers RO4003C 0.203 mm thickness
Bottom Layer: 1/2 oz Copper Cladding, 0.017 mm thickness
Finished overall thickness: 0.237 mm

Sample Board Layout: Input and Output Tuning¹⁰

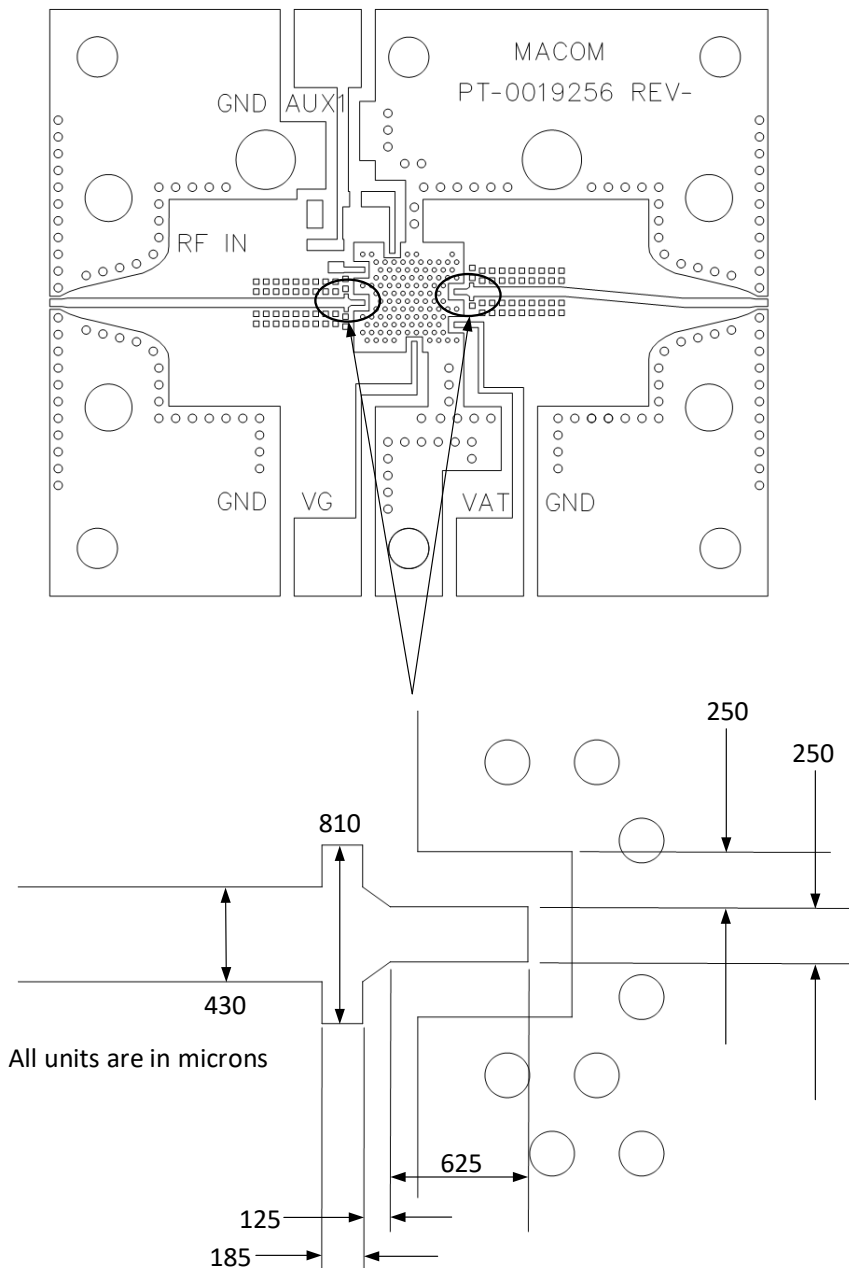

Evaluation PCB Specifications

Top Layer: 1/2 oz Copper Cladding, 0.017 mm thickness
 Dielectric Layer: Rogers RO4003C 0.203 mm thickness
 Bottom Layer: 1/2 oz Copper Cladding, 0.017 mm thickness
 Finished overall thickness: 0.237 mm

10. Input and output use the same tuning.

Typical Performance Curves: $V_{DD} = 6\text{ V}$, $I_{DSQ} = 75\text{ mA}$, $V_{AT} = 5\text{ V}$

Gain

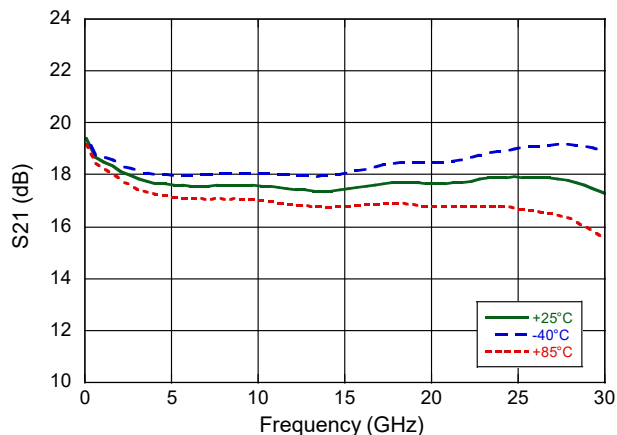

Noise Figure

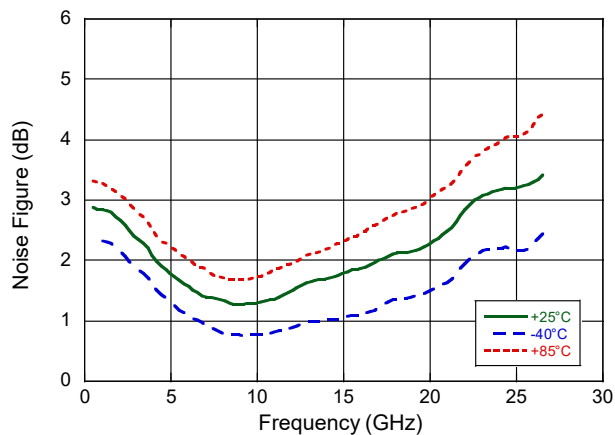

Input Return loss

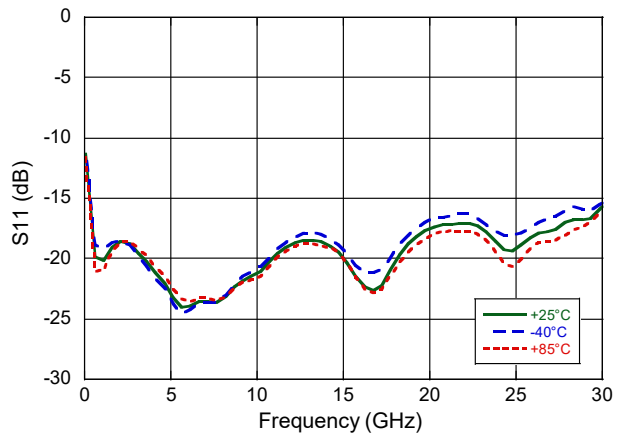

Output Return Loss

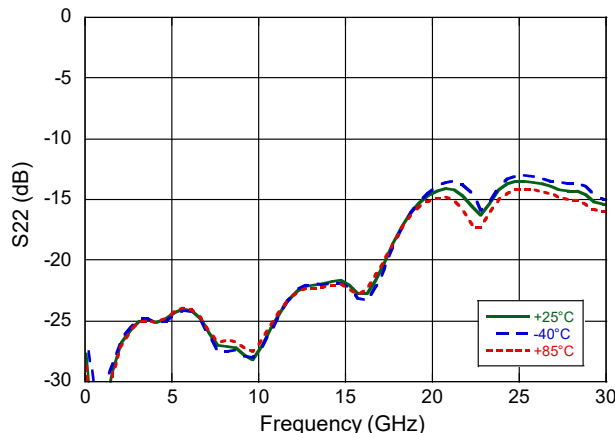

Low Frequency S-Parameters

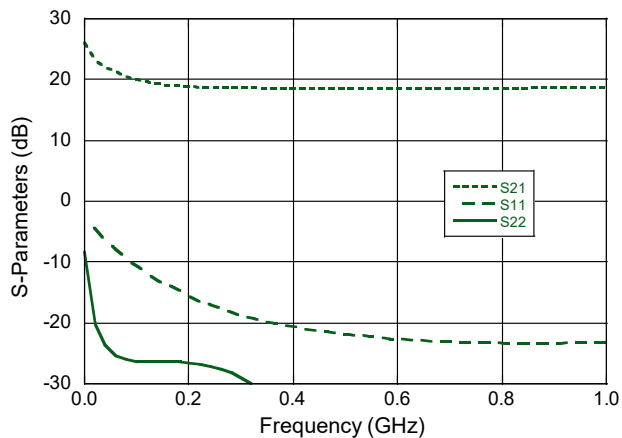

Reverse Isolation

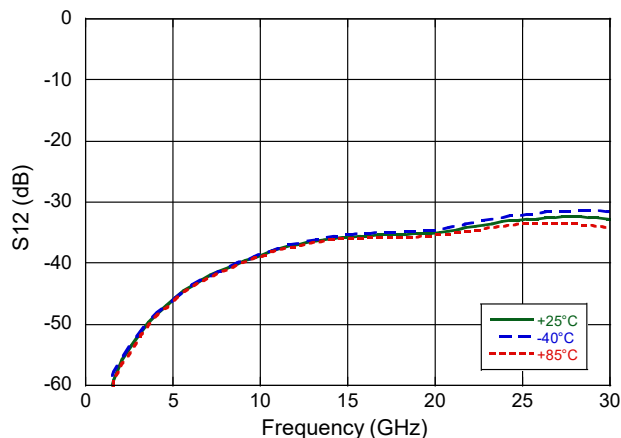

Typical Performance Curves: $V_{DD} = 6\text{ V}$, $I_{DSQ} = 75\text{ mA}$, $V_{AT} = 5\text{ V}$

Output P1dB

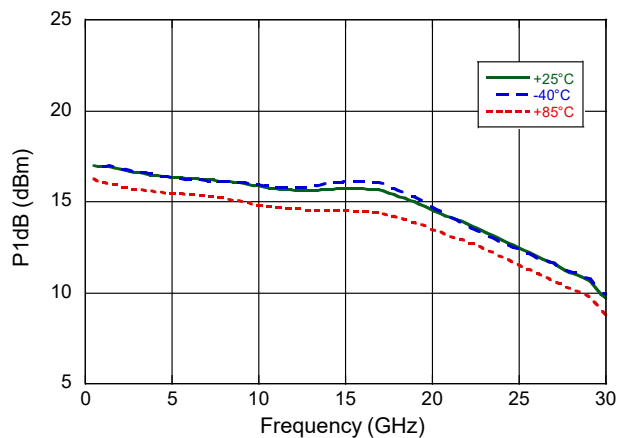

Output IP3 (10 MHz tone spacing)

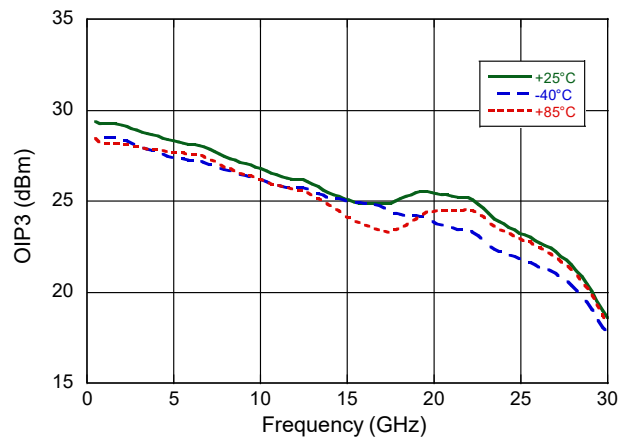

Lead-Free 5 mm 32-Lead AQFN Package[†]

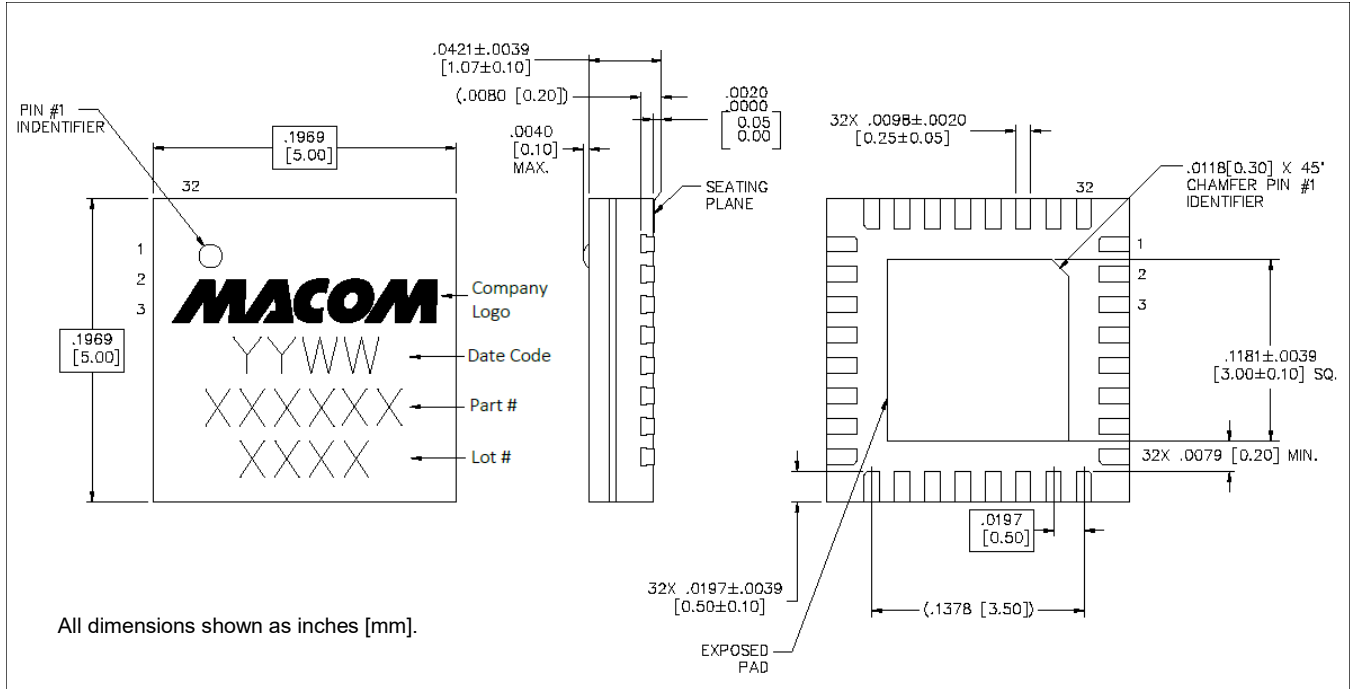

[†] Reference Application Note S2083 for lead-free solder reflow recommendations.
Meets JEDEC moisture sensitivity level 3 requirements.
Plating is NiPdAu.

MACOM Technology Solutions Inc. ("MACOM"). All rights reserved.

These materials are provided in connection with MACOM's products as a service to its customers and may be used for informational purposes only. Except as provided in its Terms and Conditions of Sale or any separate agreement, MACOM assumes no liability or responsibility whatsoever, including for (i) errors or omissions in these materials; (ii) failure to update these materials; or (iii) conflicts or incompatibilities arising from future changes to specifications and product descriptions, which MACOM may make at any time, without notice. These materials grant no license, express or implied, to any intellectual property rights.

THESE MATERIALS ARE PROVIDED "AS IS" WITH NO WARRANTY OR LIABILITY, EXPRESS OR IMPLIED, RELATING TO SALE AND/OR USE OF MACOM PRODUCTS INCLUDING FITNESS FOR A PARTICULAR PURPOSE, MERCHANTABILITY, INFRINGEMENT OF INTELLECTUAL PROPERTY RIGHT, ACCURACY OR COMPLETENESS, OR SPECIAL, INDIRECT, INCIDENTAL, OR CONSEQUENTIAL DAMAGES WHICH MAY RESULT FROM USE OF THESE MATERIALS.

MACOM products are not intended for use in medical, lifesaving or life sustaining applications. MACOM customers using or selling MACOM products for use in such applications do so at their own risk and agree to fully indemnify MACOM for any damages resulting from such improper use or sale.

Looking for pricing, stock, or lifecycle information?

Click below to explore more details on WIN SOURCE:

- ⊖ [View MAAL-011141-TR0500 on WIN SOURCE](#)
- ⊖ [M/A-Com Technology Solutions Information](#)

Optimize Your Supply Chain with WIN SOURCE Solutions

- ✓ Global Sourcing Solution
- ✓ Obsolete Management
- ✓ Cost Control Management
- ✓ Shortage Management
- ✓ Alternative Solution
- ✓ Excess Inventory Management