



**THE DATASHEET OF  
ISL4245EIRZ-T**



## ISL4238E, ISL4244E, ISL4245E

QFN Packaged, ±15kV ESD Protected, +2.7V to +5.5V, 10Nanoamp, 250kbps/  
1Mbps, RS-232 Transceivers with Enhanced Automatic Power-down

FN8038  
Rev 5.00  
May 13, 2010

The Intersil ISL4238E, ISL4244E and ISL4245E devices are 2.7V to 5.5V powered RS-232 transmitters/receivers which meet EIA/TIA-232 and V.28/V.24 specifications, even at  $V_{CC} = 3.0V$ . Additionally, they provide ±15kV ESD protection (IEC61000-4-2 Air Gap and Human Body Model) on transmitter outputs and receiver inputs (RS-232 pins). Targeted applications are PDAs, Palmtops, and notebook and laptop computers where the low operational, and even lower standby power consumption is critical. Efficient on-chip charge pumps, coupled with manual and enhanced automatic power-down functions, reduce the standby supply current to a 10nA trickle. Tiny 5mmx5mm Quad Flat No-Lead (QFN) packaging and the use of small, low value capacitors ensure board space savings as well. Data rates greater than 250kbps (ISL4238E/ISL4244E)/1Mbps (ISL4245E) are guaranteed at worst case load conditions.

The ISL424xE are 3 driver, 5 receiver (DTE) devices that, coupled with the QFN package, provide the industry's smallest, lowest power complete serial port suitable for PDAs, and laptop or notebook computers. The 32 Ld 5x5 QFN requires 60% less board area than a 28 lead TSSOP, and is nearly 20% thinner. The devices also include a noninverting always-active receiver for "wake-up" capability.

The ISL4238E is a 5 driver, 3 receiver device optimized for DCE applications with full hardware handshaking. It also includes a noninverting always-active receiver for RING INDICATOR monitoring. Transmitter and logic inputs include active feedback resistors that retain the input state once driven to a valid logic level.

These devices feature an *enhanced automatic power-down* function which powers down the on-chip power-supply and driver circuits. This occurs when all receiver and transmitter inputs detect no signal transitions for a period of 30s. These devices power back-up, automatically, whenever they sense a transition on any transmitter or receiver input.

Table 1 summarizes the features of the ISL4238E, ISL4244E, ISL4245, while Application Note AN9863 summarizes the features of each device comprising the 3V RS-232 family.

### Features

- Parameters Fully Specified for 10% Tolerance Supplies and Full Industrial Temp Range
- Available in Small QFN (5mm x 5mm) Package which is 60% Smaller than a 28 Lead TSSOP
- ESD Protection for RS-232 I/O Pins to ±15kV (IEC61000)
- DTE (ISL4244E/45E) and DCE (ISL4238E) Versions
- Lowest Supply Current in Power-down . . . . . 10nA
- Active Feedback Resistors on  $T_X$  and Logic Inputs (ISL4238E)
- Flow Through Pinouts
- Manual and Enhanced Automatic Power-down Features
- Guaranteed Minimum Data Rate  
250kbps (ISL4238E/ISL4244E) / 1Mbps (ISL4245E)
- Latch-Up Free
- On-Chip Charge Pumps Require Only Four External 0.1µF Capacitors
- Wide Power Supply Range . . . . . Single +2.7V to +5.5V
- Meets EIA/TIA-232 and V.28/V.24 Specifications at 3V
- RS-232 Compatible with  $V_{CC} = 2.7V$
- Pb-Free Available (RoHS Compliant)

### Applications

- Any Space Constrained System Requiring RS-232 Ports
  - Battery Powered, Hand-Held, and Portable Equipment
  - Laptop Computers, Notebooks
  - PDAs and Palmtops, Data Cables
  - Cellular/Mobile Phones, Digital Cameras, GPS Receivers

### Related Literature

- Technical Brief TB363 "Guidelines for Handling and Processing Moisture Sensitive Surface Mount Devices"
- Technical Brief TB379 "Thermal Characterization of Packages for ICs"
- Technical Brief TB389 "PCB Land Pattern Design and Surface Mount Guidelines for QFN Packages"

TABLE 1. SUMMARY OF FEATURES

PART NUMBER	NO. OF Tx.	NO. OF Rx.	CONFIG.	QFN PKG.	NO. OF MONITOR Rx. (R <sub>OUTB</sub> )	DATA RATE (kbps)	Rx. ENABLE FUNCTION?	MANUAL POWER-DOWN?	ENHANCED AUTOMATIC POWER-DOWN FUNCTION?
ISL4238E	5	3	DCE	5x5	1	250	No	Yes	Yes
ISL4244E	3	5	DTE	5x5	1	250	No	Yes	Yes
ISL4245E	3	5	DTE	5x5	1	1000	No	Yes	Yes

### Ordering Information

PART NUMBER	PART MARKING	TEMP. RANGE (°C)	PACKAGE	PKG. DWG. #
ISL4238EIR	ISL 4238EIR	-40 to +85	32 Ld 5X5 QFN	L32.5x5B
ISL4238EIRZ (Note)	ISL4238 EIRZ	-40 to +85	32 Ld 5X5 QFN (Pb-Free)	L32.5x5B
ISL4238EIR-T*	ISL 4238EIR	-40 to +85	32 Ld 5X5 QFN Tape & Reel	L32.5x5B
ISL4238EIRZ-T* (Note)	ISL4238 EIRZ	-40 to +85	32 Ld 5X5 QFN Tape & Reel, (Pb-Free)	L32.5x5B
ISL4244EIR	ISL 4244EIR	-40 to +85	32 Ld 5X5 QFN	L32.5x5B
ISL4244EIRZ (Note)	ISL4244 EIRZ	-40 to +85	32 Ld 5X5 QFN (Pb-free)	L32.5x5B
ISL4244EIR-T*	ISL 4244EIR	-40 to +85	32 Ld 5X5 QFN Tape & Reel	L32.5x5B
ISL4244EIRZ-T* (Note)	ISL4244 EIRZ	-40 to +85	32 Ld 5X5 QFN Tape & Reel, (Pb-Free)	L32.5x5B
ISL4245EIR	ISL 4245EIR	-40 to +85	32 Ld 5X5 QFN	L32.5x5B
ISL4245EIRZ (Note)	ISL4245 EIRZ	-40 to +85	32 Ld 5X5 QFN (Pb-Free)	L32.5x5B
ISL4245EIR-T*	ISL 4245EIR	-40 to +85	32 Ld 5X5 QFN Tape & Reel	L32.5x5B
ISL4245EIRZ-T* (Note)	ISL4245 EIRZ	-40 to +85	32 Ld 5X5 QFN Tape & Reel, (Pb-Free)	L32.5x5B

\*Please refer to TB347 for details on reel specifications.

NOTE: These Intersil Pb-free plastic packaged products employ special Pb-free material sets, molding compounds/die attach materials, and 100% matte tin plate plus anneal (e3 termination finish, which is RoHS compliant and compatible with both SnPb and Pb-free soldering operations). Intersil Pb-free products are MSL classified at Pb-free peak reflow temperatures that meet or exceed the Pb-free requirements of IPC/JEDEC J STD-020.

**Pinouts**

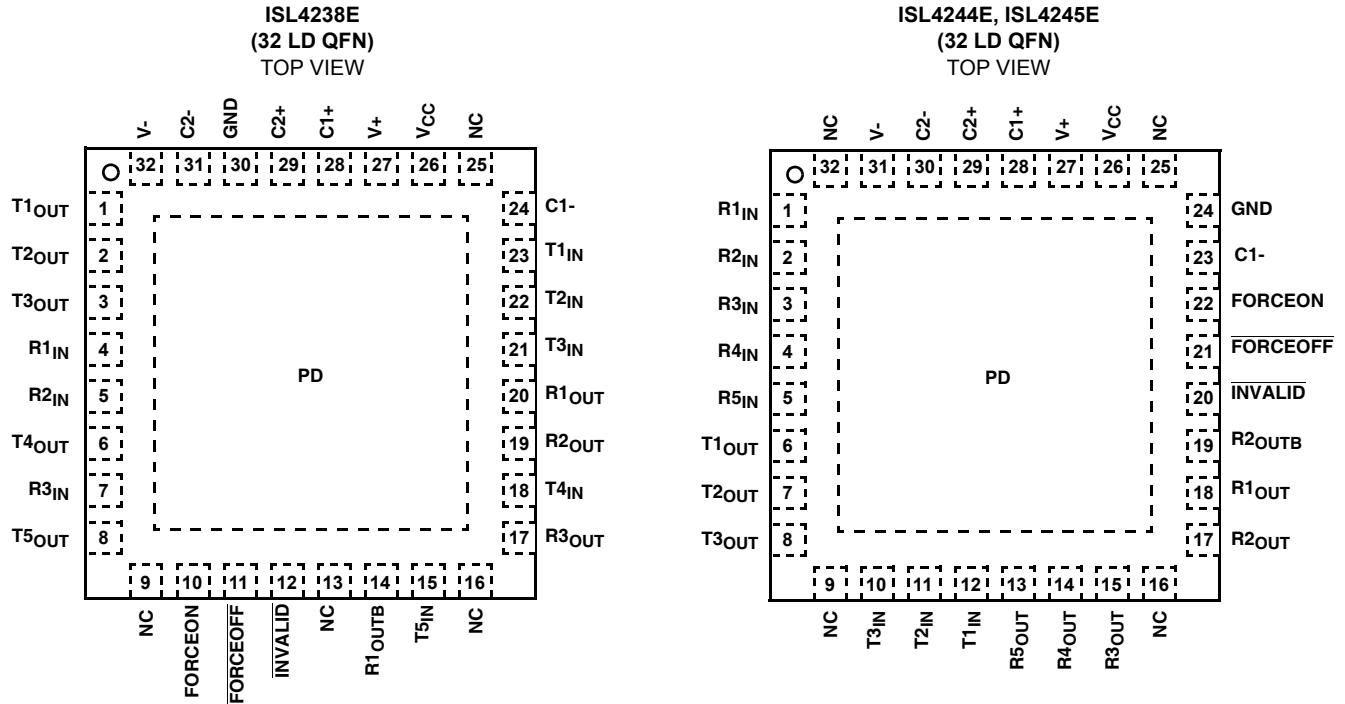

**Pin Descriptions**

PIN	FUNCTION
V <sub>CC</sub>	System power supply input (2.7V to 5.5V).
V+	Internally generated positive transmitter supply (+5.5V).
V-	Internally generated negative transmitter supply (-5.5V).
GND	Ground connection. This is also the potential of the thermal pad (PD).
C1+	External capacitor (voltage doubler) is connected to this lead.
C1-	External capacitor (voltage doubler) is connected to this lead.
C2+	External capacitor (voltage inverter) is connected to this lead.
C2-	External capacitor (voltage inverter) is connected to this lead.
T <sub>IN</sub>	TTL/CMOS compatible transmitter Inputs. (Note)
T <sub>OUT</sub>	±15kV ESD Protected, RS-232 level (nominally ±5.5V) transmitter outputs.
R <sub>IN</sub>	±15kV ESD Protected, RS-232 compatible receiver inputs.
R <sub>OUT</sub>	TTL/CMOS level receiver outputs.
R <sub>OUTB</sub>	TTL/CMOS level, noninverting, always enabled receiver outputs.
$\overline{\text{INVALID}}$	Active low output that indicates if no valid RS-232 levels are present on any receiver input.
$\overline{\text{FORCEOFF}}$	Active low to shut down transmitters and on-chip power supply. This overrides any automatic circuitry and FORCEON (see Table 2).
FORCEON	Active high input to override automatic power-down circuitry thereby keeping transmitters active. ( $\overline{\text{FORCEOFF}}$ must be high).
NC	No Connection
PD	Exposed Thermal Pad. Connect to GND.

NOTE: ISL4238E input pins incorporate positive feedback resistors. Once the input is driven to a valid logic level, the feedback resistor maintains that logic level until V<sub>CC</sub> is removed. Unused transmitter inputs may be left unconnected by the user.

**Typical Operating Circuits**

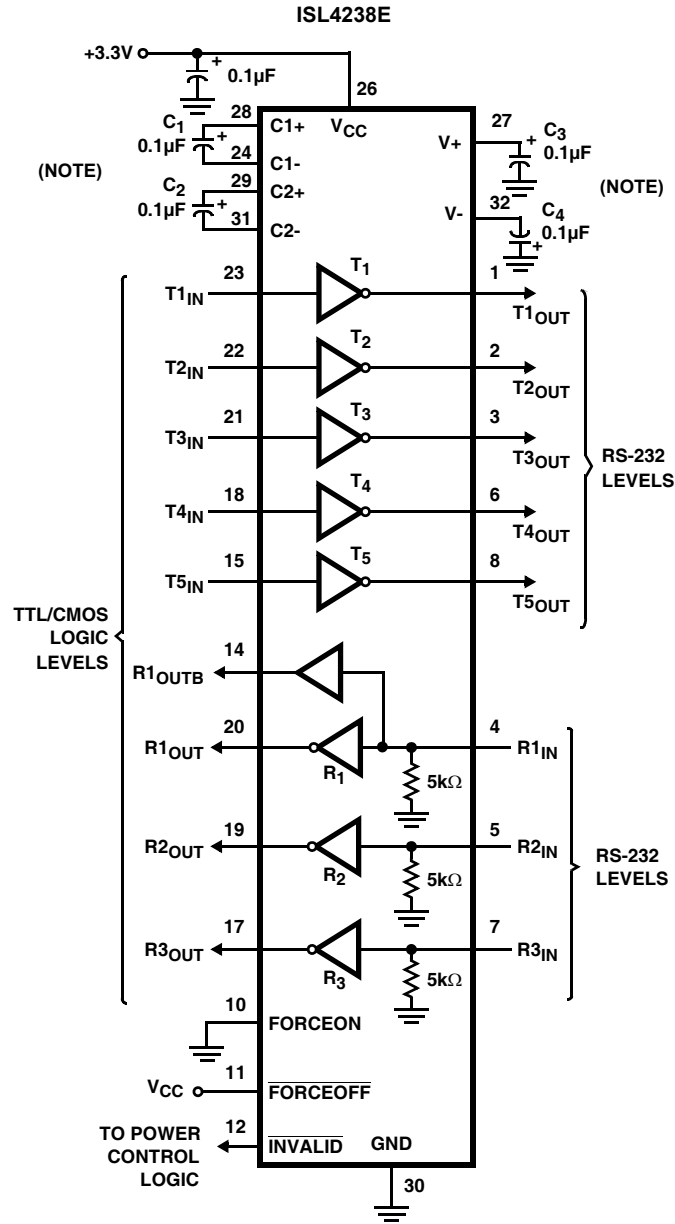

NOTE: For  $V_{CC} = 3.15V$  (3.3V -5%), use  $C_1$  to  $C_4 = 0.1\mu F$  or greater. For  $V_{CC} = 3.0V$  (3.3V -10%), use  $C_1$  to  $C_4 = 0.22\mu F$  or greater.

**Typical Operating Circuits** (Continued)

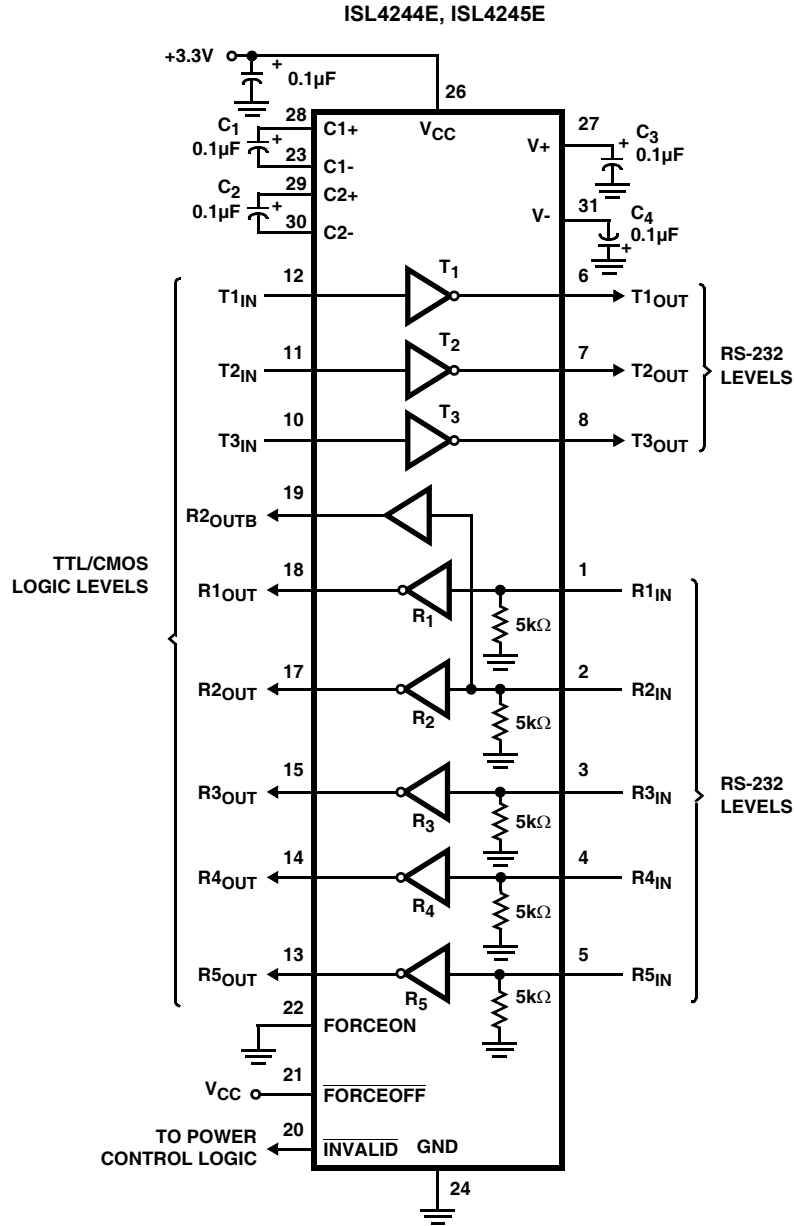

**Absolute Maximum Ratings**

V <sub>CC</sub> to Ground	-0.3V to 6V
V+ to Ground	-0.3V to 7V
V- to Ground	+0.3V to -7V
V+ to V-	14V
<b>Input Voltages</b>	
T <sub>IN</sub> , FORCEOFF, FORCEON	-0.3V to 6V
R <sub>IN</sub>	±25V
<b>Output Voltages</b>	
T <sub>OUT</sub>	±13.2V
R <sub>OUT</sub> , INVALID	-0.3V to V <sub>CC</sub> +0.3V
<b>Short Circuit Duration</b>	
T <sub>OUT</sub>	Continuous
ESD Rating	See "ESD PERFORMANCE" on page 8

**Thermal Information**

Thermal Resistance (Typical, Notes 1, 2)	θ <sub>JA</sub> (°C/W)	θ <sub>JC</sub> (°C/W)
32 Ld QFN Package	32	3.0
Moisture Sensitivity (see Technical Brief TB363)		
QFN Package	Level 1	
Maximum Storage Temperature Range	-65°C to +150°C	
Pb-Free Reflow Profile	see link below	
<a href="http://www.intersil.com/pbfree/Pb-FreeReflow.asp">http://www.intersil.com/pbfree/Pb-FreeReflow.asp</a>		

**Operating Conditions**

Temperature Range	ISL42xxEIR	-40°C to +85°C
-------------------	------------	----------------

*CAUTION: Do not operate at or near the maximum ratings listed for extended periods of time. Exposure to such conditions may adversely impact product reliability and result in failures not covered by warranty.*

**NOTE:**

1. θ<sub>JA</sub> is measured in free air with the component mounted on a high effective thermal conductivity test board with "direct attach" features. See Tech Brief TB379, and Tech Brief TB389.
2. For θ<sub>JC</sub>, the "case temp" location is the center of the exposed metal pad on the package underside.

**Electrical Specifications** Test Conditions: ISL4238E V<sub>CC</sub> = 3.15V to 5.5V, C<sub>1</sub> to C<sub>4</sub> = 0.1µF; V<sub>CC</sub> = 3V, C<sub>1</sub> to C<sub>4</sub> = 0.22µF; ISL424xE V<sub>CC</sub> = 3V to 5.5V, C<sub>1</sub> to C<sub>4</sub> = 0.1µF; Unless Otherwise Specified. Typical values are at T<sub>A</sub> = +25°C

PARAMETER	TEST CONDITIONS	TEMP (°C)	MIN (Note 7)	TYP	MAX (Note 7)	UNITS
<b>DC CHARACTERISTICS</b>						
Operating Voltage Range		Full	2.7	-	5.5	V
Supply Current, Automatic Power-down	All R <sub>IN</sub> Open, FORCEON = GND, FORCEOFF = V <sub>CC</sub>	25	-	3	300	nA
		Full		50	300	nA
Supply Current, Power-down	All R <sub>IN</sub> Open, FORCEOFF = GND	25	-	3	300	nA
		Full		50	300	nA
Supply Current, Automatic Power-down Disabled	All Outputs Unloaded, FORCEON = FORCEOFF = V <sub>CC</sub> , V <sub>CC</sub> = 3.0V	25	-	0.3	1.0	mA
		Full		0.3	1.5	mA
<b>LOGIC AND TRANSMITTER INPUTS AND RECEIVER OUTPUTS</b>						
Input Logic Threshold Low	T <sub>IN</sub> , FORCEON, FORCEOFF	Full	-	-	0.8	V
Input Logic Threshold High	T <sub>IN</sub> , FORCEON, FORCEOFF, V <sub>CC</sub> = 3.6V	Full	2.0	-	-	V
Transmitter Input Hysteresis		25	-	0.5	-	V
Input Leakage Current	T <sub>IN</sub> , FORCEON, FORCEOFF (ISL4238E, Note 3)	Full	-	±0.01	±1.0	µA
Output Leakage Current	FORCEOFF = GND	Full	-	±0.05	±10	µA
Output Voltage Low	I <sub>OUT</sub> = 1.6mA	Full	-	-	0.4	V
Output Voltage High	I <sub>OUT</sub> = -1.0mA	Full	V <sub>CC</sub> - 0.6	V <sub>CC</sub> - 0.1	-	V
<b>RECEIVER INPUTS</b>						
Input Voltage Range		Full	-25	-	25	V
Input Threshold Low	V <sub>CC</sub> = 3.0V	Full	-	1.0	0.6	V
Input Threshold High	V <sub>CC</sub> = 3.6V	Full	2.4	1.5	-	V
Input Hysteresis		25	-	0.5	-	V
Input Resistance		Full	3	5	7	kΩ
<b>TRANSMITTER OUTPUTS</b>						
Output Voltage Swing	All Transmitter Outputs Loaded with 3kΩ to Ground	Full	±5.0	±5.4	-	V
Output Resistance	V <sub>CC</sub> = V+ = V- = 0V, Transmitter Output = ±2V	Full	300	10M	-	Ω
Output Short-Circuit Current		Full	-	±35	±60	mA
Output Leakage Current	V <sub>OUT</sub> = ±12V, V <sub>CC</sub> = 0V or 3V to 5.5V, Automatic Power-down or FORCEOFF = GND	Full	-	-	±25	µA

**Electrical Specifications** Test Conditions: ISL4238E  $V_{CC} = 3.15V$  to  $5.5V$ ,  $C_1$  to  $C_4 = 0.1\mu F$ ;  $V_{CC} = 3V$ ,  $C_1$  to  $C_4 = 0.22\mu F$ ;  
ISL424xE  $V_{CC} = 3V$  to  $5.5V$ ,  $C_1$  to  $C_4 = 0.1\mu F$ ; Unless Otherwise Specified. Typicals are at  $T_A = +25^\circ C$

PARAMETER	TEST CONDITIONS	TEMP (°C)	MIN (Note 7)	TYP	MAX (Note 7)	UNITS	
<b>ENHANCED AUTOMATIC POWER-DOWN</b> (FORCEON = GND, FORCEOFF = $V_{CC}$ )							
Receiver Input Thresholds to INVALID High	(see Figure 6)	Full	-2.7	-	2.7	V	
Receiver Input Thresholds to INVALID Low	(see Figure 6)	Full	-0.3	-	0.3	V	
INVALID, Output Voltage Low	$I_{OUT} = 1.6mA$	Full	-	-	0.4	V	
INVALID, Output Voltage High	$I_{OUT} = -1.0mA$	Full	$V_{CC} - 0.6$	-	-	V	
Receiver Positive or Negative Threshold to INVALID High Delay ( $t_{INVH}$ )		25	-	0.5	1	$\mu s$	
		Full	-	0.9	1.5	$\mu s$	
Receiver Positive or Negative Threshold to INVALID Low Delay ( $t_{INVL}$ )	ISL4238E	25	-	60	100	$\mu s$	
		Full		100	150	$\mu s$	
Receiver Positive or Negative Threshold to INVALID Low Delay ( $t_{INVL}$ )	ISL4244E/ISL42445E	25	-	30	50	$\mu s$	
		Full		40	60	$\mu s$	
Receiver or Transmitter Edge to Transmitters Enabled Delay ( $t_{WU}$ )	(Note 4)	Full	-	20	100	$\mu s$	
Receiver or Transmitter Edge to Transmitters Disabled Delay ( $t_{AUTOPWDN}$ )	(Note 4)	Full	15	30	60	sec	
<b>TIMING CHARACTERISTICS</b>							
Maximum Data Rate ISL4238E/4244E	$R_L = 3k\Omega$ , $C_L = 1000pF$ , One Transmitter Switching	Full	250	500	-	kbps	
Maximum Data Rate ISL4245E	$R_L = 3k\Omega$ , One Transmitter Switching	$C_L = 1000pF$	Full	250	900	-	kbps
		$V_{CC} = 3V$ to $4.5V$ , $C_L = 250pF$	Full	1000	2000	-	kbps
		$V_{CC} = 4.5V$ to $5.5V$ , $C_L = 1000pF$	Full	1000	1500	-	kbps
Receiver Propagation Delay	Receiver Input to Receiver Output, $C_L = 150pF$	$t_{PHL}$	25	-	0.15	0.3	$\mu s$
			Full	-	0.2	0.35	$\mu s$
		$t_{PLH}$	25	-	0.3	0.5	$\mu s$
			Full	-	0.35	0.55	$\mu s$
Receiver Skew	$t_{PHL} - t_{PLH}$ , $C_L = 150pF$	25	-	120	250	ns	
		Full	-	150	300	ns	
Transmitter Propagation Delay ISL4238E/44E	Transmitter Input to Transmitter Output, $C_L = 1000pF$ , $R_L = 3k\Omega$	$t_{PHL}$	25	-	0.75	1	$\mu s$
			Full	-	0.85	1.1	$\mu s$
		$t_{PLH}$	25	-	0.8	1	$\mu s$
			Full	-	0.9	1.1	$\mu s$
Transmitter Skew ISL4238E/44E	$t_{PHL} - t_{PLH}$ (see Note 6), $R_L = 3k\Omega$ , $C_L = 1000pF$	25	-	50	200	ns	
		Full	-	100	250	ns	
Transmitter Propagation Delay ISL4245E	Transmitter Input to Transmitter Output, $C_L = 1000pF$ , $R_L = 3k\Omega$	$t_{PHL}$	25	-	0.4	0.8	$\mu s$
			Full	-	0.5	0.8	$\mu s$
		$t_{PLH}$	25	-	0.35	0.7	$\mu s$
			Full	-	0.4	0.7	$\mu s$
Transmitter Skew ISL4245E	$t_{PHL} - t_{PLH}$ (see Note 5), $R_L = 3k\Omega$ , $C_L = 1000pF$	25	-	50	200	ns	
		Full	-	60	250	ns	
Receiver Output Enable Time	Normal Operation, $R_L = 1k\Omega$ to $0.5V_{CC}$ , $C_L = 15pF$	25	-	200	350	ns	
		Full	-	200	400	ns	

**Electrical Specifications** Test Conditions: ISL4238E  $V_{CC} = 3.15V$  to  $5.5V$ ,  $C_1$  to  $C_4 = 0.1\mu F$ ;  $V_{CC} = 3V$ ,  $C_1$  to  $C_4 = 0.22\mu F$ ;  
ISL424xE  $V_{CC} = 3V$  to  $5.5V$ ,  $C_1$  to  $C_4 = 0.1\mu F$ ; Unless Otherwise Specified. Typicals are at  $T_A = +25^\circ C$

PARAMETER	TEST CONDITIONS	TEMP (°C)	MIN (Note 7)	TYP	MAX (Note 7)	UNITS	
Receiver Output Disable Time	Normal Operation, $R_L = 1k\Omega$ to $0.5V_{CC}$ , $C_L = 15pF$	25	-	350	500	ns	
		Full	-	400	600	ns	
Transmitter Output Enable Time ISL4238E/ISL4244E/ISL4245E	Normal Operation, $R_L = 3k\Omega$ , $C_L = 1000pF$	25	-	25	40	$\mu s$	
		Full	-	35	50	$\mu s$	
Transmitter Output Disable Time ISL4238E/ISL4244E/ISL4245E	Normal Operation, $R_L = 3k\Omega$ , $C_L = 1000pF$	25	-	2.5	4	$\mu s$	
		Full	-	2.7	4	$\mu s$	
Transition Region Slew Rate ISL4238E/ISL4244E	$V_{CC} = 3V$ to $3.6V$ , $R_L = 3k\Omega$ to $7k\Omega$ , Measured From $3V$ to $-3V$ or $-3V$ to $3V$	$C_L = 150pF$ to $1000pF$	25	6	11	30	$V/\mu s$
			Full	6	10	30	$V/\mu s$
	$C_L = 150pF$ to $2500pF$	25	4	9	30	$V/\mu s$	
		Full	4	8	30	$V/\mu s$	
Transition Region Slew Rate ISL4245E	$V_{CC} = 3V$ to $3.6V$ , $R_L = 3k\Omega$ to $7k\Omega$ , Measured From $3V$ to $-3V$ or $-3V$ to $3V$ , $C_L = 150pF$ to $1000pF$	25	24	40	150	$V/\mu s$	
		Full	24	35	150	$V/\mu s$	
<b>ESD PERFORMANCE</b>							
RS-232 Pins ( $T_{OUT}$ , $R_{IN}$ )	Human Body Model		25	-	$\pm 15$	-	kV
	IEC61000-4-2 Air Gap Discharge		25	-	$\pm 15$	-	kV
	IEC61000-4-2 Contact Discharge		25	-	$\pm 8$	-	kV
All Other Pins	Human Body Model		25	-	$\pm 3$	-	kV

## NOTES:

- ISL4238E inputs utilize a positive feedback resistor. The input current is negligible when the input is at either supply rail.
- An "edge" is defined as a transition through the transmitter or receiver input thresholds.
- Skew is measured at the receiver input switching points (1.4V).
- Skew is measured at the transmitter zero crossing points.
- Parameters with MIN and/or MAX limits are 100% tested at  $+25^\circ C$ , unless otherwise specified. Temperature limits established by characterization and are not production tested.

## Detailed Description

These interface ICs operate from a single  $+2.7V$  to  $+5.5V$  supply, guarantee a 250kbps (ISL4238E/ISL4244E)/1Mbps (ISL4245E) minimum data rate, require only four small external  $0.1\mu F$  capacitors, feature low power consumption, and meet all EIA RS-232C and V.28 specifications. The circuit is divided into three sections: The charge pump, the transmitters, and the receivers.

### Charge-Pump

Intersil's new RS-232 family utilizes regulated on-chip dual charge pumps as voltage doublers, and voltage inverters to generate  $\pm 5.5V$  transmitter supplies from a  $V_{CC}$  supply as low as  $3.0V$ . This allows these devices to maintain RS-232 compliant output levels over the  $\pm 10\%$  tolerance range of  $3.3V$  powered systems. The efficient on-chip power supplies require only four small, external  $0.1\mu F$  capacitors for the voltage doubler and inverter functions. The charge pumps operate discontinuously (i.e., they turn off as soon as the V+ and V- supplies are pumped up to the nominal values), resulting in significant power savings.

### Transmitters

The transmitters are proprietary, low dropout, inverting drivers that translate TTL/CMOS inputs to EIA/TIA-232 output levels. Coupled with the on-chip  $\pm 5.5V$  supplies, these transmitters deliver true RS-232 levels over a wide range of single supply system voltages.

Transmitter outputs disable and assume a high impedance state when the device enters the power-down mode (see Table 2). These outputs may be driven to  $\pm 12V$  when disabled.

The ISL4238E/ISL4244E guarantee a 250kbps data rate for full load conditions ( $3k\Omega$  and  $1000pF$ ),  $V_{CC} \geq 3.0V$ , with one transmitter operating at full speed. Under more typical conditions of  $V_{CC} \geq 3.3V$ ,  $R_L = 3k\Omega$ , and  $C_L = 250pF$ , one transmitter easily operates at 1Mbps.

The ISL4245E guarantees a 1Mbps data rate for full load conditions ( $3k\Omega$  and  $250pF$ ),  $V_{CC} \geq 3.0V$ , with one transmitter operating at full speed. Under more typical conditions of  $V_{CC} \geq 3.3V$ ,  $R_L = 3k\Omega$ , and  $C_L = 250pF$ , one transmitter easily operates at 1.4Mbps.

Transmitter inputs on the ISL424XE float if left unconnected, and may cause  $I_{CC}$  increases. Connect unused inputs to

TABLE 2. POWER-DOWN LOGIC TRUTH TABLE

RCVR OR XMTR EDGE WITHIN 30 SEC?	FORCEOFF INPUT	FORCEON INPUT	TRANSMITTER OUTPUTS	RECEIVER OUTPUTS	ROUTB OUTPUTS	RS-232 LEVEL PRESENT AT RECEIVER INPUT?	INVALID OUTPUT	MODE OF OPERATION
NO	H	H	Active	Active	Active	No	L	Normal Operation (Enhanced Auto Power-down Disabled)
NO	H	H	Active	Active	Active	Yes	H	
YES	H	L	Active	Active	Active	No	L	Normal Operation (Enhanced Auto Power-down Enabled)
YES	H	L	Active	Active	Active	Yes	H	
NO	H	L	High-Z	Active	Active	No	L	Power-down Due to Enhanced Auto Power-down Logic
NO	H	L	High-Z	Active	Active	Yes	H	
X	L	X	High-Z	High-Z	Active	No	L	Manual Power-down
X	L	X	High-Z	High-Z	Active	Yes	H	
<b>INVALID DRIVING FORCEON AND FORCEOFF (EMULATES AUTOMATIC POWER-DOWN)</b>								
X	Note 8	Note 8	Active	Active	Active	Yes	H	Normal Operation
X	Note 8	Note 8	High-Z	High-Z	Active	No	L	Forced Auto Power-down

NOTE:

8. Input is connected to  $\overline{\text{INVALID}}$  Output.

GND for the best performance. ISL4238E transmitter inputs incorporate an active positive feedback resistor that maintains the last input state in the absence of a forcing signal, so unused transmitter inputs may be left unconnected.

**Receivers**

ISL4238E, ISL4244E, ISL4245 devices contain standard inverting receivers which can tristate via the FORCEOFF control line. Additionally, they include a noninverting (monitor) receiver (denoted by the ROUTB label) that is always active, regardless of the state of any control lines. Both receiver types convert RS-232 signals to CMOS output levels and accept inputs up to ±25V while presenting the required 3kΩ to 7kΩ input impedance (see Figure 1) even if the power is off (VCC = 0V). The receivers' Schmitt trigger input stage uses hysteresis to increase noise immunity and decrease errors due to slow input signal transitions.

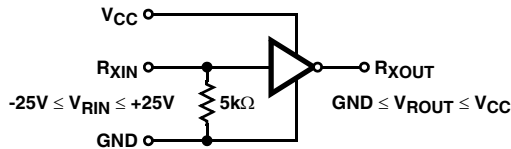

FIGURE 1. INVERTING RECEIVER CONNECTIONS

The ISL4238E, ISL4244E, ISL4245 inverting receivers disable during forced (manual) power-down, but not during automatic power-down (see Table 2). Conversely, the monitor receiver remains active even during manual power-down making it extremely useful for Ring Indicator monitoring. Standard receivers driving powered down peripherals must be disabled to prevent current flow through the peripheral's protection diodes (see Figures 2 and 3). This

renders them useless for wake up functions, but the corresponding monitor receiver can be dedicated to this task as shown in Figure 3.

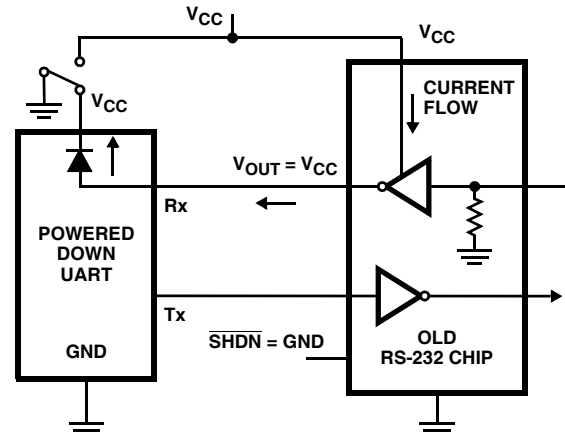

FIGURE 2. POWER DRAIN THROUGH POWERED DOWN PERIPHERAL

**Low Power Operation**

These 3V devices require a nominal supply current of 0.3mA, even at VCC = 5.5V, during normal operation (not in power-down mode). This is considerably less than the 5mA to 11mA current required by comparable 5V RS-232 devices, allowing users to reduce system power simply by switching to this new family.

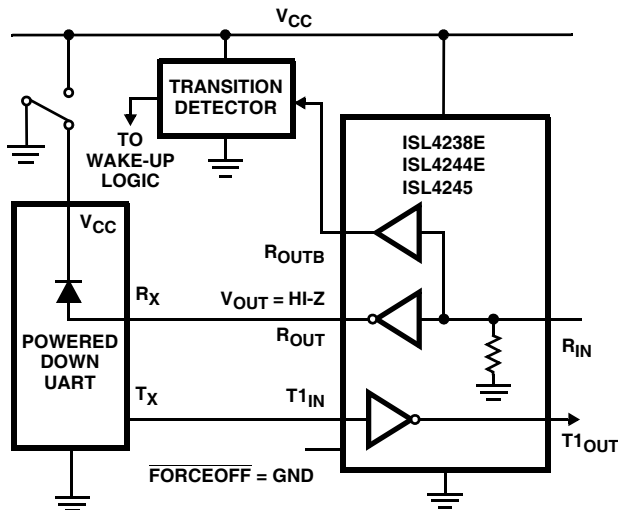

FIGURE 3. DISABLED RECEIVERS PREVENT POWER DRAIN

### Power-down Functionality

The already low current requirement drops significantly when the device enters power-down mode. In power-down, supply current drops to 10nA, because the on-chip charge pump turns off ( $V+$  collapses to  $V_{CC}$ ,  $V-$  collapses to GND), and the transmitter outputs tristate. Inverting receiver outputs disable only in manual power-down; refer to Table 2 for details. This micro-power mode makes these devices ideal for battery powered and portable applications.

### Software Controlled (Manual) Power-down

These devices allow the user to force the IC into the low power, standby state, and utilize a two pin approach where the  $\overline{\text{FORCEON}}$  and  $\overline{\text{FORCEOFF}}$  inputs determine the IC's mode. For always enabled operation,  $\overline{\text{FORCEON}}$  and  $\overline{\text{FORCEOFF}}$  are both strapped high. To switch between active and power-down modes, under logic or software control, only the  $\overline{\text{FORCEOFF}}$  input need be driven. The  $\overline{\text{FORCEON}}$  state isn't critical, as  $\overline{\text{FORCEOFF}}$  dominates over  $\overline{\text{FORCEON}}$ . Nevertheless, if strictly manual control over power-down is desired, the user must strap  $\overline{\text{FORCEON}}$  high to disable the enhanced automatic power-down circuitry. ISL4238E, ISL4244E, ISL4245 inverting (standard) receiver outputs also disable when the device is in manual power-down, thereby eliminating the possible current path through a shutdown peripheral's input protection diode (see Figures 2 and 3).

Connecting  $\overline{\text{FORCEOFF}}$  and  $\overline{\text{FORCEON}}$  together disables the enhanced automatic power-down feature, enabling them to function as a manual SHUTDOWN input (see Figure 4).

With any of the previous mentioned control schemes, the time required to exit power-down, and resume transmission is only 100 $\mu$ s.

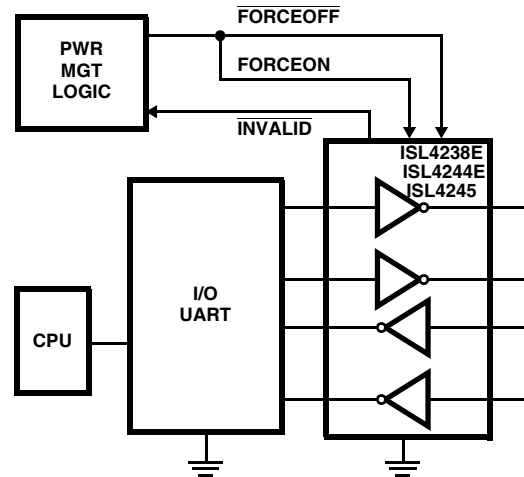

FIGURE 4. CONNECTIONS FOR MANUAL POWER-DOWN WHEN NO VALID RECEIVER SIGNALS ARE PRESENT

When using both manual and enhanced automatic power-down ( $\overline{\text{FORCEON}} = 0$ ), the ISL4238E, ISL4244E, ISL4245 won't power up from manual power-down until both  $\overline{\text{FORCEOFF}}$  and  $\overline{\text{FORCEON}}$  are driven high, or until a transition occurs on a receiver or transmitter input. Figure 5 illustrates a circuit for ensuring that the ISL4238E, ISL4244E, ISL4245 powers up as soon as  $\overline{\text{FORCEOFF}}$  switches high. The rising edge of the Master Power-down signal forces the device to power up, and the ISL4238E, ISL4244E, ISL4245 returns to enhanced automatic power-down mode an RC time constant after this rising edge. The time constant isn't critical, because the ISL4238E, ISL4244E, ISL4245 remains powered up for 30s after the  $\overline{\text{FORCEON}}$  falling edge, even if there are no signal transitions. This gives slow-to-wake systems (e.g., a mouse) plenty of time to start transmitting, and as long as it starts transmitting within 30s both systems remain enabled.

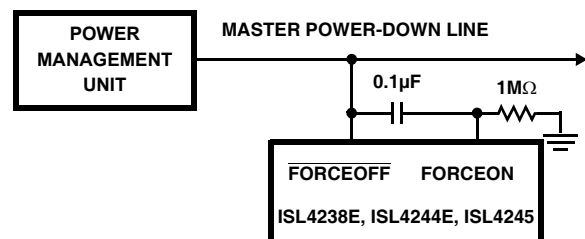

FIGURE 5. CIRCUIT TO ENSURE IMMEDIATE POWER UP WHEN EXITING FORCED POWER-DOWN

### INVALID Output

The  $\overline{\text{INVALID}}$  output always indicates (see Table 2) whether or not 30 $\mu$ s have elapsed with invalid RS-232 signals (see Figures 6 and 9) persisting on all of the receiver inputs, giving the user an easy way to determine when the interface block should power down. Invalid receiver levels occur whenever the driving peripheral's outputs are shut off (powered down) or when the RS-232 interface cable is disconnected. In the case of a disconnected interface cable where all the receiver inputs are

floating (but pulled to GND by the internal receiver pull down resistors), the  $\overline{\text{INVALID}}$  logic detects the invalid levels and drives the output low. The power management logic then uses this indicator to power down the interface block. Reconnecting the cable restores valid levels at the receiver inputs,  $\overline{\text{INVALID}}$  switches high, and the power management logic wakes up the interface block.  $\overline{\text{INVALID}}$  can also be used to indicate the DTR or RING INDICATOR signal, as long as the other receiver inputs are floating, or driven to GND (as in the case of a powered down driver).

$\overline{\text{INVALID}}$  switches high  $1\mu\text{s}$  after detecting a valid RS-232 level on a receiver input.  $\overline{\text{INVALID}}$  operates in all modes (forced or automatic power-down, or forced on), so it is also useful for systems employing manual power-down circuitry.

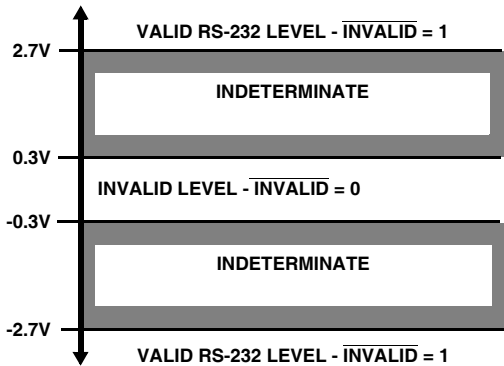

FIGURE 6. DEFINITION OF VALID RS-232 RECEIVER LEVELS

**Enhanced Automatic Power-down**

Even greater power savings is available by using these devices which feature an *enhanced automatic* power-down function. When the enhanced power-down logic determines that no transitions have occurred on any of the transmitter nor receiver inputs for 30 seconds, the charge pump and transmitters power-down, thereby reducing supply current to **10nA**. The ISL4238E, ISL4244E, ISL4245 automatically powers back up whenever it detects a transition on one of these inputs. This automatic power-down feature provides additional system power savings without changes to the existing operating system.

Enhanced automatic power-down operates when the FORCEON input is low, and the  $\overline{\text{FORCEOFF}}$  input is high. Tying FORCEON high disables automatic power-down, but manual power-down is always available via the overriding  $\overline{\text{FORCEOFF}}$  input. Table 2 summarizes the enhanced automatic power-down functionality.

Figure 7 illustrates the enhanced power-down control logic. Note that once the ISL4238E, ISL4244E, ISL4245 enters power-down (manually or automatically), the 30 second timer remains timed out (set), keeping the ISL4238E, ISL4244E, ISL4245 powered down until FORCEON transitions high, or until a transition occurs on a receiver or transmitter input.

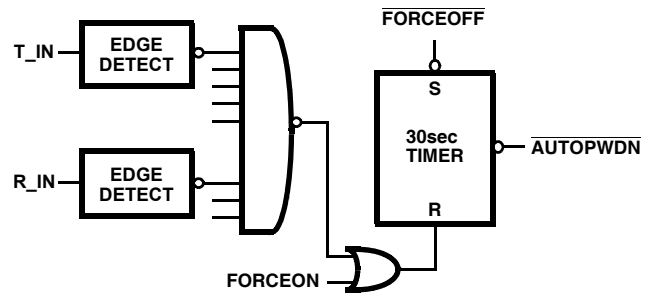

FIGURE 7. ENHANCED AUTOMATIC POWER-DOWN LOGIC

The  $\overline{\text{INVALID}}$  output signal switches low to indicate that invalid levels have persisted on all of the receiver inputs for more than  $30\mu\text{s}$  (see Figure 9), but this has no direct effect on the state of the ISL4238E, ISL4244E, ISL4245 (see the next sections for methods of utilizing  $\overline{\text{INVALID}}$  to power down the device).

The time to recover from automatic power-down mode is typically  $100\mu\text{s}$ .

**Emulating Standard Automatic Power-down**

If enhanced automatic power-down isn't desired, the user can implement the standard automatic power-down feature (mimics the function on the ISL4243E) by connecting the  $\overline{\text{INVALID}}$  output to the FORCEON and  $\overline{\text{FORCEOFF}}$  inputs, as shown in Figure 8. After  $30\mu\text{s}$  of invalid receiver levels,  $\overline{\text{INVALID}}$  switches low and drives the ISL4238E, ISL4244E, ISL4245 into a forced power-down condition.  $\overline{\text{INVALID}}$  switches high as soon as a receiver input senses a valid RS-232 level, forcing the ISL4238E, ISL4244E, ISL4245 to power on. See the " $\overline{\text{INVALID}}$  DRIVING FORCEON AND  $\overline{\text{FORCEOFF}}$ " section of Table 2 for an operational summary. This operational mode is perfect for handheld devices that communicate with another computer via a detachable cable. Detaching the cable allows the internal receiver pull-down resistors to pull the inputs to GND (an invalid RS-232 level), causing the  $30\mu\text{s}$  timer to time-out and drive the IC into power-down. Reconnecting the cable restores valid levels, causing the IC to power back up.

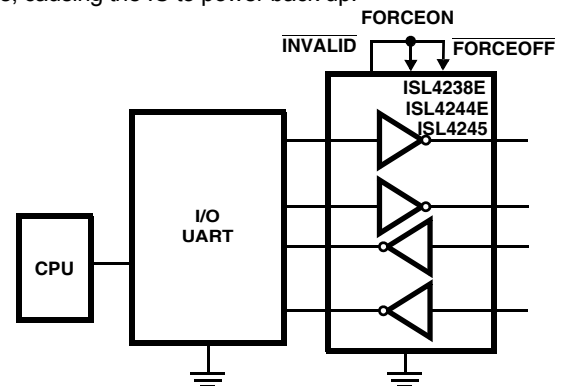

FIGURE 8. CONNECTIONS FOR AUTOMATIC POWER-DOWN WHEN NO VALID RECEIVER SIGNALS ARE PRESENT

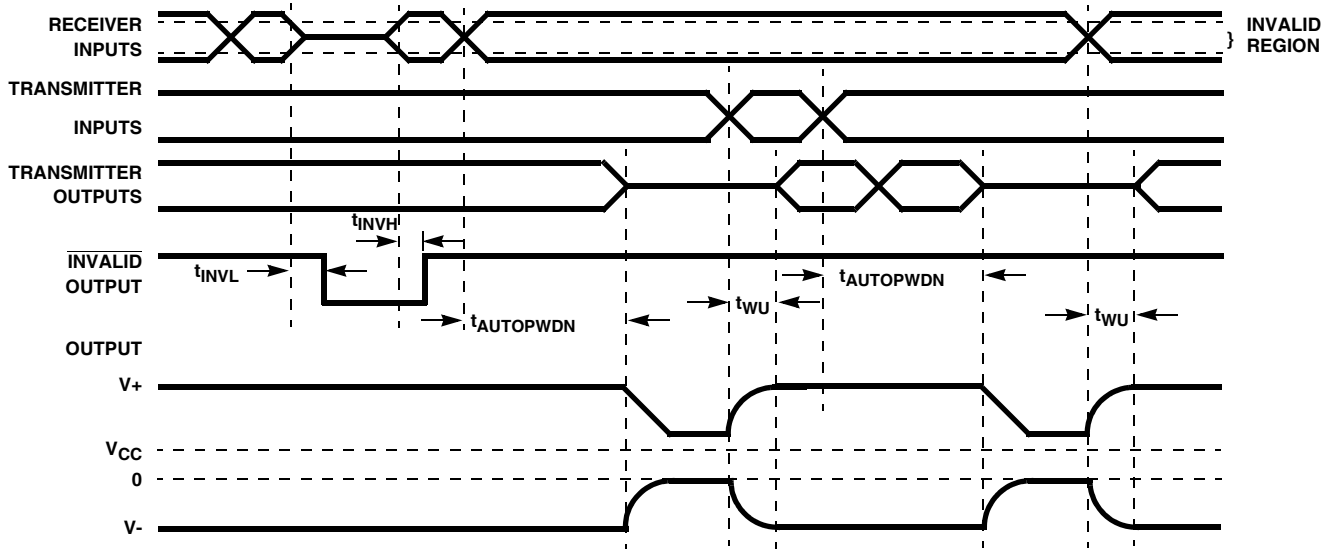

FIGURE 9. ENHANCED AUTOMATIC POWER-DOWN AND  $\overline{\text{INVALID}}$  TIMING DIAGRAMS

**Hybrid Automatic Power-down Options**

For devices which communicate only through a detachable cable, connecting  $\overline{\text{INVALID}}$  to  $\overline{\text{FORCEOFF}}$  (with  $\text{FORCEON} = 0$ ) may be a desirable configuration. While the

cable is attached  $\overline{\text{INVALID}}$  and  $\overline{\text{FORCEOFF}}$  remain high, so the enhanced automatic power-down logic powers down the RS-232 device whenever there is 30 seconds of inactivity on the receiver and transmitter inputs. Detaching the cable allows the receiver inputs to drop to an invalid level (GND), so  $\overline{\text{INVALID}}$  switches low and forces the RS-232 device to power down. The ISL4238E, ISL4244E, ISL4245 remains powered down until the cable is reconnected ( $\overline{\text{INVALID}} = \overline{\text{FORCEOFF}} = 1$ ) and a transition occurs on a receiver or transmitter input (see Figure 7). For immediate power up when the cable is reattached, connect  $\text{FORCEON}$  to  $\overline{\text{FORCEOFF}}$  through a network similar to that shown in Figure 5.

**Capacitor Selection**

The ISL4238E charge pumps require 0.1 $\mu\text{F}$ , or greater, capacitors for 3.3V (5% tolerance) operation. For other supply voltages refer to Table 3 for capacitor values. Do not use values smaller than those listed in Table 3.

TABLE 3. REQUIRED CAPACITOR VALUES (ISL4238E)

V <sub>CC</sub> (V)	C <sub>1</sub> ( $\mu\text{F}$ )	C <sub>2</sub> , C <sub>3</sub> , C <sub>4</sub> ( $\mu\text{F}$ )
3.0 to 3.6 (3.3V $\pm 10\%$ )	0.22	0.22
3.15 to 3.6 (3.3V $\pm 5\%$ )	0.1	0.1
4.5 to 5.5	0.047	0.33
3.0 to 5.5	0.22	1

The ISL4244E/45E charge pumps require 0.1 $\mu\text{F}$  capacitors for proper operation. Increasing the capacitor values (by a factor of 2) reduces ripple on the transmitter outputs and

slightly reduces power consumption. C<sub>2</sub>, C<sub>3</sub>, and C<sub>4</sub> can be increased without increasing C<sub>1</sub>'s value, however, do not increase C<sub>1</sub> without also increasing C<sub>2</sub>, C<sub>3</sub>, and C<sub>4</sub> to maintain the proper ratios (C<sub>1</sub> to the other capacitors).

When using minimum required capacitor values, make sure that capacitor values do not degrade excessively with temperature. If in doubt, use capacitors with a larger nominal value. The capacitor's equivalent series resistance (ESR) usually rises at low temperatures and it influences the amount of ripple on V+ and V-.

**Power Supply Decoupling**

In most circumstances a 0.1 $\mu\text{F}$  bypass capacitor is adequate. In applications that are particularly sensitive to power supply noise, decouple V<sub>CC</sub> to ground with a capacitor of the same value as the charge-pump capacitor C<sub>1</sub>. Connect the bypass capacitor as close as possible to the IC.

**Transmitter Outputs when Exiting Power-down**

Figure 10 shows the response of two transmitter outputs when exiting power-down mode. As they activate, the two transmitter outputs properly go to opposite RS-232 levels, with no glitching, ringing, nor undesirable transients. Each transmitter is loaded with 3k $\Omega$  in parallel with 250pF. Note that the transmitters enable only when the magnitude of the supplies exceed approximately 3V.

**Operation Down to 2.7V**

ISL4238E, ISL4244E, ISL4245 transmitter outputs meet RS-562 levels ( $\pm 3.7\text{V}$ ), at the full data rate, with V<sub>CC</sub> as low as 2.7V. RS-562 levels typically ensure interoperability with RS-232 devices.

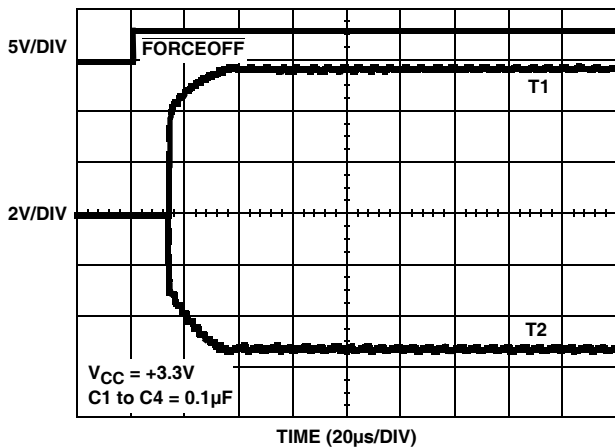

FIGURE 10. TRANSMITTER OUTPUTS WHEN EXITING POWER-DOWN

### Mouse Driveability

The ISL424XE are specifically designed to power a serial mouse while operating from low voltage supplies. Figure 11 shows the transmitter output voltages under increasing load current. The on-chip switching regulator ensures the transmitters will supply at least  $\pm 5V$  during worst case conditions (15mA for paralleled V+ transmitters, 7.3mA for single V- transmitter).

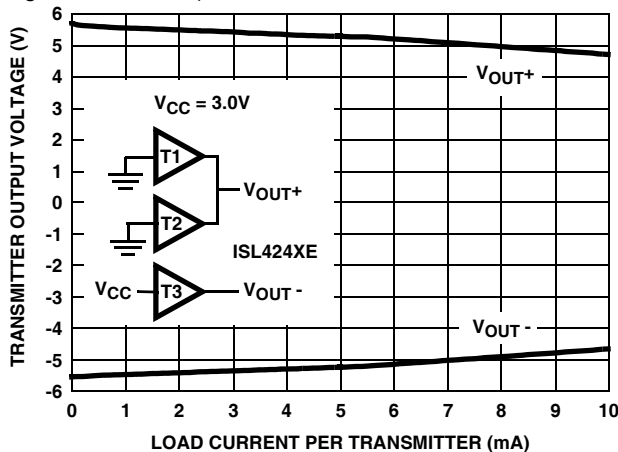

FIGURE 11. TRANSMITTER OUTPUT VOLTAGE vs LOAD CURRENT (PER TRANSMITTER, i.e., DOUBLE CURRENT AXIS FOR TOTAL  $V_{OUT+}$  CURRENT)

### High Data Rates

The ISL4238E, ISL4244E, ISL4245 maintain the RS-232  $\pm 5V$  minimum transmitter output voltages even at high data rates. Figure 12 details a transmitter loopback test circuit, and Figure 13 illustrates the ISL4238E/ISL4244E loopback test result at 120kbps. For this test, all transmitters were simultaneously driving RS-232 loads in parallel with 1000pF, at 120kbps. Figure 14 shows the ISL4238E/ISL4244E loopback results for a single transmitter driving 1000pF and an RS-232 load at 250kbps. Figure 15 illustrates the ISL4245E loopback test result at 250kbps. For this test, all transmitters were simultaneously driving RS-232 loads in parallel with 1000pF, at 250kbps. Figure 16 shows the

ISL4245E loopback results for a single transmitter driving 250pF and an RS-232 load at 1Mbps. The static transmitters were also loaded with an RS-232 receiver.

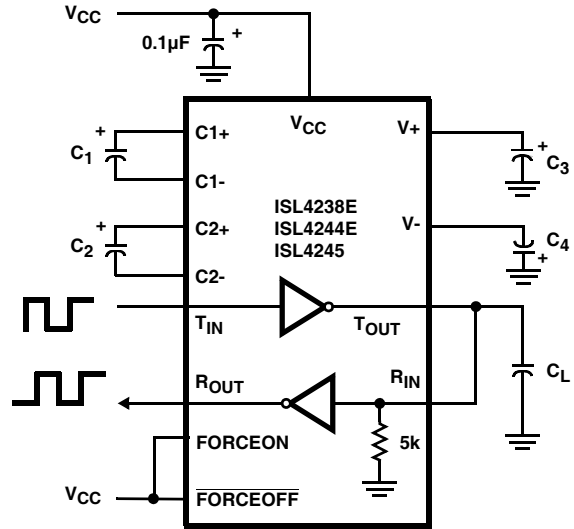

FIGURE 12. TRANSMITTER LOOPBACK TEST CIRCUIT

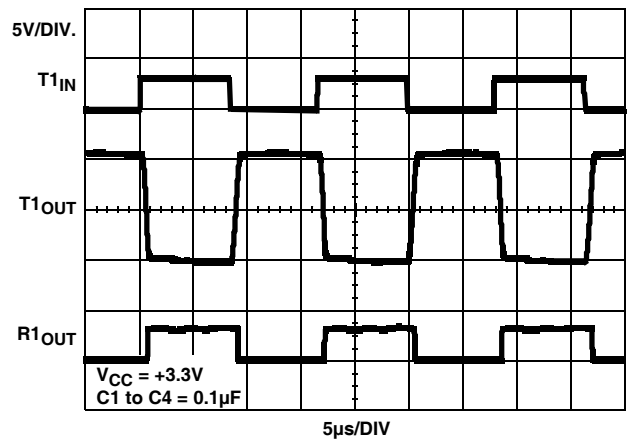

FIGURE 13. ISL4238E/ISL4244E LOOPBACK TEST AT 120kbps

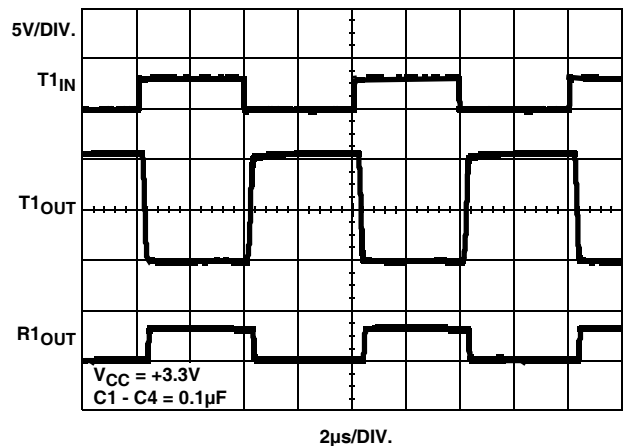

FIGURE 14. ISL4238E/ISL4244E LOOPBACK TEST AT 250kbps ( $C_L = 1000pF$ )

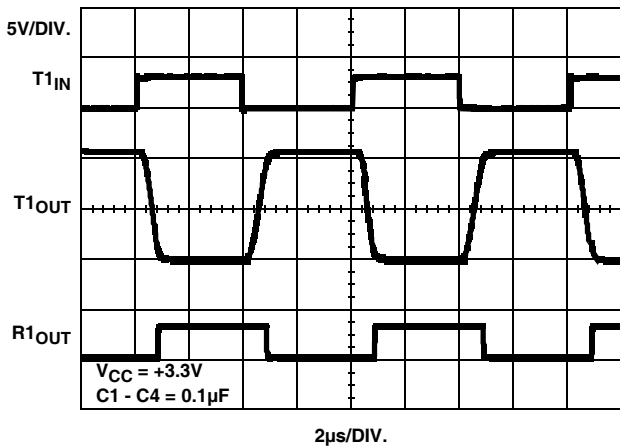

FIGURE 15. ISL4245E LOOPBACK TEST AT 250kbps

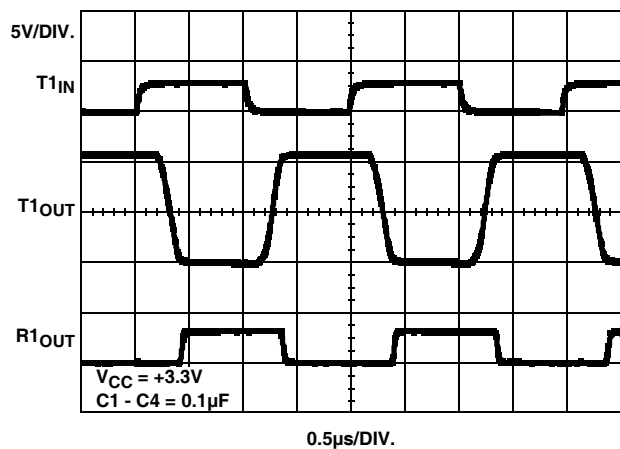

FIGURE 16. ISL4245E LOOPBACK TEST AT 1Mbps  
( $C_L = 250\text{pF}$ )

### Interconnection with 3V and 5V Logic

The ISL4238E, ISL4244E, ISL4245 directly interface with 5V CMOS and TTL logic families. Nevertheless, with the ISL4238E, ISL4244E, ISL4245 at 3.3V, and the logic supply at 5V, AC, HC, and CD4000 outputs can drive ISL4238E, ISL4244E, ISL4245 inputs, but ISL4238E, ISL4244E, ISL4245 outputs do not reach the minimum  $V_{IH}$  for these logic families. See Table 4 for more information.

TABLE 4. LOGIC FAMILY COMPATIBILITY WITH VARIOUS SUPPLY VOLTAGES

SYSTEM POWER-SUPPLY VOLTAGE (V)	$V_{CC}$ SUPPLY VOLTAGE (V)	COMPATIBILITY
3.3	3.3	Compatible with all CMOS families.
5	5	Compatible with all TTL and CMOS logic families.
5	3.3	Compatible with ACT and HCT CMOS, and with TTL. ISL4238E, ISL4244E, ISL4245 outputs are incompatible with AC, HC, and CD4000 CMOS inputs.

### ±15kV ESD Protection

All pins on ISL4238E, ISL4244E, ISL4245 devices include ESD protection structures, but the RS-232 pins (transmitter outputs and receiver inputs) incorporate advanced structures which allow them to survive ESD events up to ±15kV. The RS-232 pins are particularly vulnerable to ESD damage because they typically connect to an exposed port on the exterior of the finished product. Simply touching the port pins, or connecting a cable, can cause an ESD event that might destroy unprotected ICs. These new ESD structures protect the device whether or not it is powered up, protect without allowing any latchup mechanism to activate, and don't interfere with RS-232 signals as large as ±25V.

### Human Body Model (HBM) Testing

As the name implies, this test method emulates the ESD event delivered to an IC during human handling. The tester delivers the charge through a 1.5kΩ current limiting resistor, making the test less severe than the IEC61000 test which utilizes a 330Ω limiting resistor. The HBM method determines an IC's ability to withstand the ESD transients typically present during handling and manufacturing. Due to the random nature of these events, each pin is tested with respect to all other pins. The RS-232 pins on "E" family devices can withstand HBM ESD events to ±15kV.

### IEC61000-4-2 Testing

The IEC61000 test method applies to finished equipment, rather than to an individual IC. Therefore, the pins most likely to suffer an ESD event are those that are exposed to the outside world (the RS-232 pins in this case), and the IC is tested in its typical application configuration (power applied) rather than testing each pin-to-pin combination. The lower current limiting resistor coupled with the larger charge storage capacitor yields a test that is much more severe than the HBM test. The extra ESD protection built into this device's RS-232 pins allows the design of equipment meeting level 4 criteria without the need for additional board level protection on the RS-232 port.

### AIR-GAP DISCHARGE TEST METHOD

For this test method, a charged probe tip moves toward the IC pin until the voltage arcs to it. The current waveform delivered to the IC pin depends on approach speed, humidity, temperature, etc., so it is difficult to obtain repeatable results. The "E" device RS-232 pins withstand ±15kV air-gap discharges.

### CONTACT DISCHARGE TEST METHOD

During the contact discharge test, the probe contacts the tested pin before the probe tip is energized, thereby eliminating the variables associated with the air-gap discharge. The result is a more repeatable and predictable test, but equipment limits prevent testing devices at voltages higher than ±8kV. All "E" family devices survive ±8kV contact discharges on the RS-232 pins.

**Typical Performance Curves**  $V_{CC} = 3.3V, T_A = +25^{\circ}C$

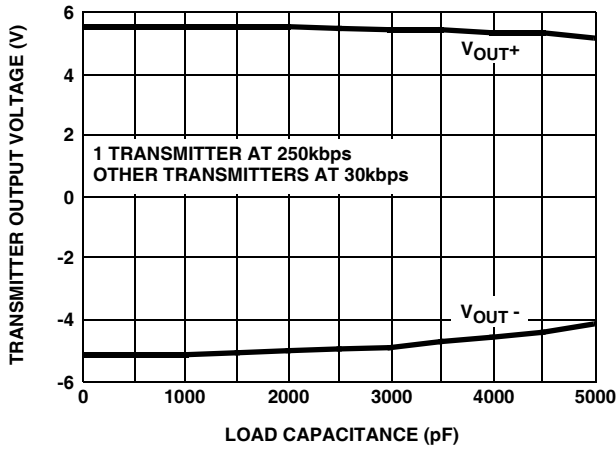

FIGURE 17. ISL4238E TRANSMITTER OUTPUT VOLTAGE vs LOAD CAPACITANCE

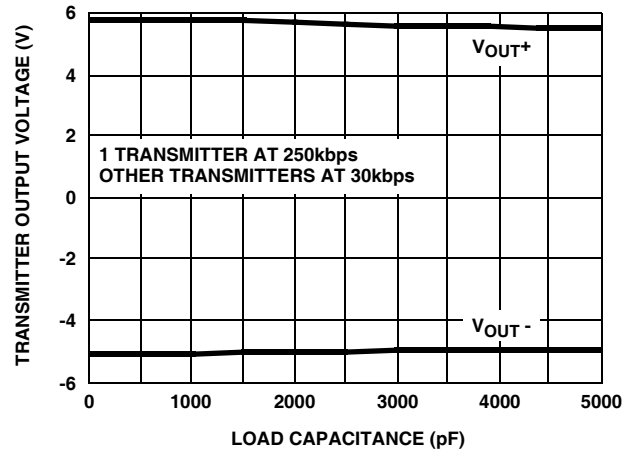

FIGURE 18. ISL4244E TRANSMITTER OUTPUT VOLTAGE vs LOAD CAPACITANCE

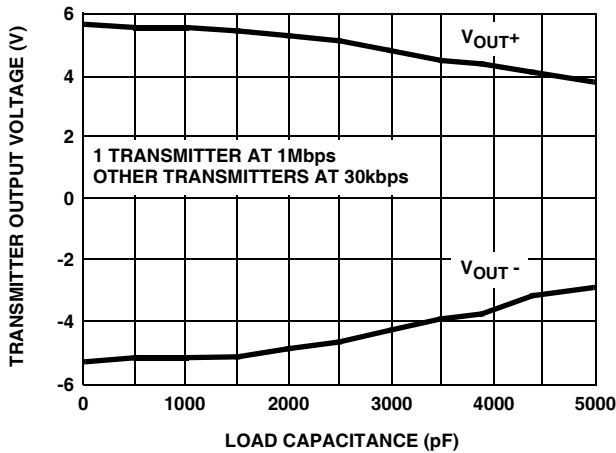

FIGURE 19. ISL4245E TRANSMITTER OUTPUT VOLTAGE vs LOAD CAPACITANCE

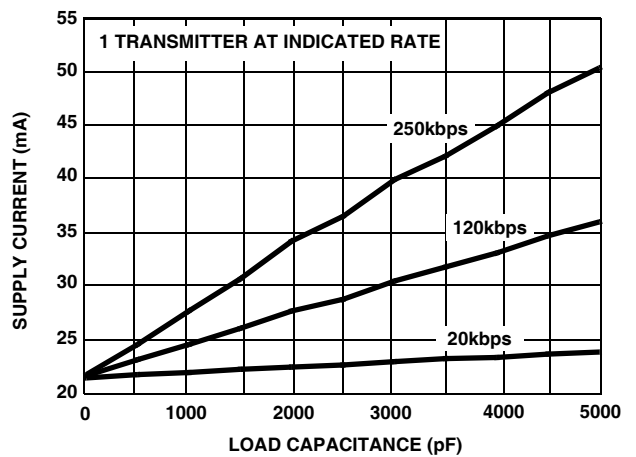

FIGURE 20. ISL4238E SUPPLY CURRENT vs LOAD CAPACITANCE WHEN TRANSMITTING DATA

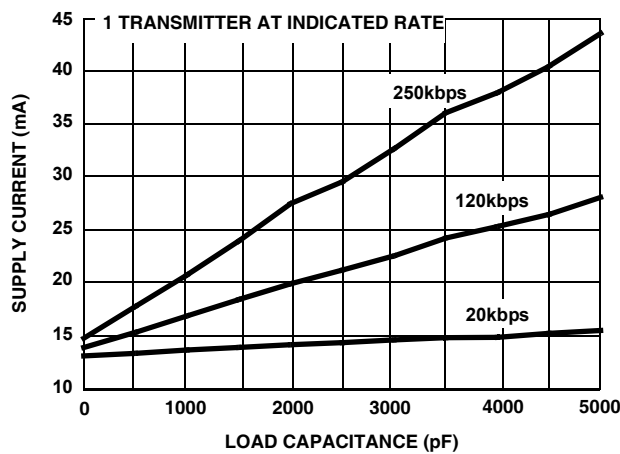

FIGURE 21. ISL4244E SUPPLY CURRENT vs LOAD CAPACITANCE WHEN TRANSMITTING DATA

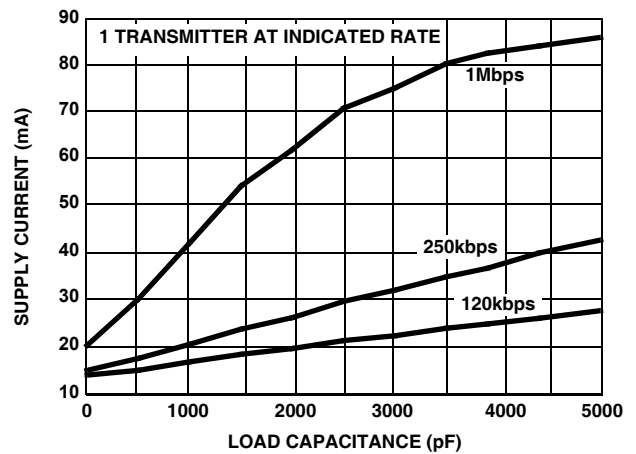

FIGURE 22. ISL4245E SUPPLY CURRENT vs LOAD CAPACITANCE WHEN TRANSMITTING DATA

**Typical Performance Curves**  $V_{CC} = 3.3V, T_A = +25^{\circ}C$  (Continued)

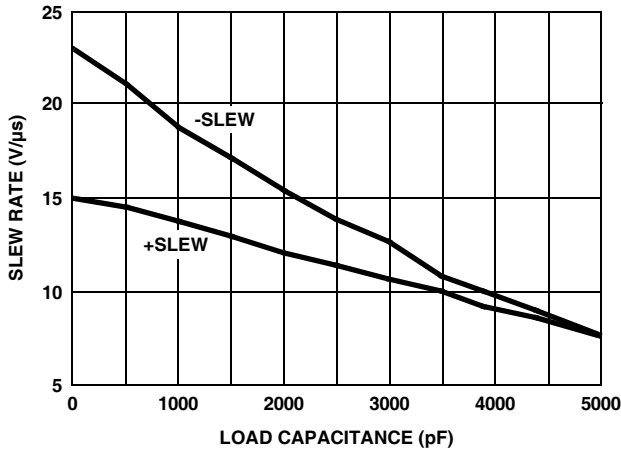

FIGURE 23. ISL4238E/ISL4244E SLEW RATE vs LOAD CAPACITANCE

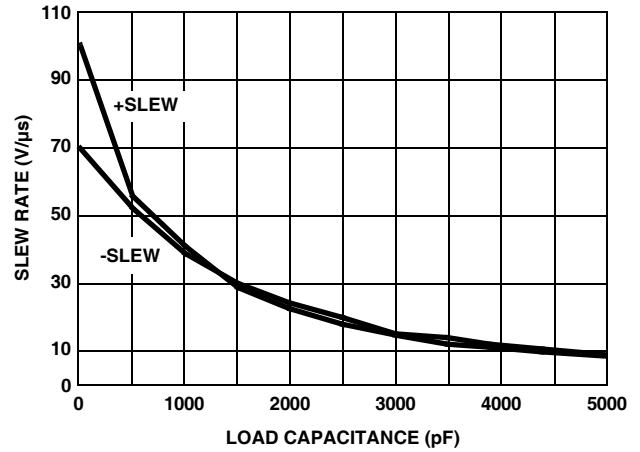

FIGURE 24. ISL4245E SLEW RATE vs LOAD CAPACITANCE

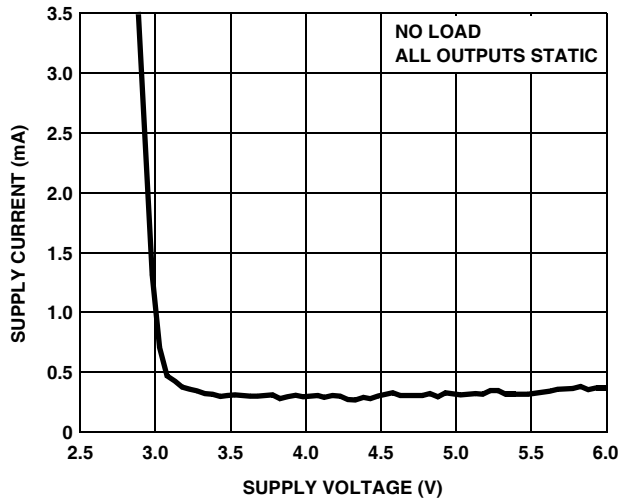

FIGURE 25. SUPPLY CURRENT vs SUPPLY VOLTAGE

**Die Characteristics**

**SUBSTRATE AND QFN THERMAL PAD POTENTIAL (POWERED UP):**

GND

**TRANSISTOR COUNT**

ISL4238E: 1235

ISL4244E: 1109

ISL4245E: 1109

**PROCESS**

Si Gate BiCMOS

© Copyright Intersil Americas LLC 2002-2010. All Rights Reserved.  
All trademarks and registered trademarks are the property of their respective owners.

For additional products, see [www.intersil.com/en/products.html](http://www.intersil.com/en/products.html)

Intersil products are manufactured, assembled and tested utilizing ISO9001 quality systems as noted in the quality certifications found at [www.intersil.com/en/support/qualandreliability.html](http://www.intersil.com/en/support/qualandreliability.html)

*Intersil products are sold by description only. Intersil may modify the circuit design and/or specifications of products at any time without notice, provided that such modification does not, in Intersil's sole judgment, affect the form, fit or function of the product. Accordingly, the reader is cautioned to verify that datasheets are current before placing orders. Information furnished by Intersil is believed to be accurate and reliable. However, no responsibility is assumed by Intersil or its subsidiaries for its use; nor for any infringements of patents or other rights of third parties which may result from its use. No license is granted by implication or otherwise under any patent or patent rights of Intersil or its subsidiaries.*

For information regarding Intersil Corporation and its products, see [www.intersil.com](http://www.intersil.com)

# Package Outline Drawing

## L32.5x5B

### 32 LEAD QUAD FLAT NO-LEAD PLASTIC PACKAGE

Rev 2, 11/07

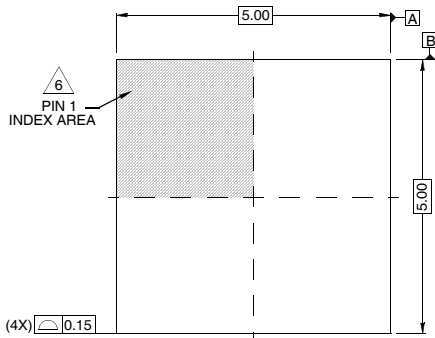

TOP VIEW

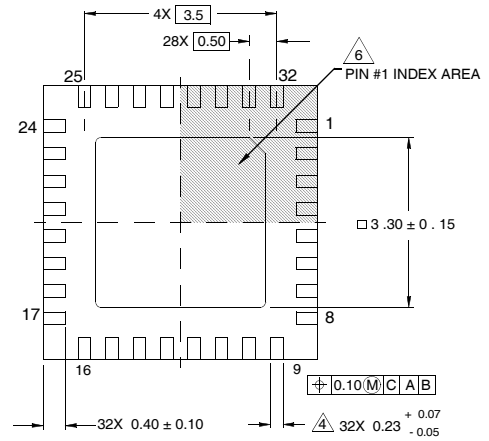

BOTTOM VIEW

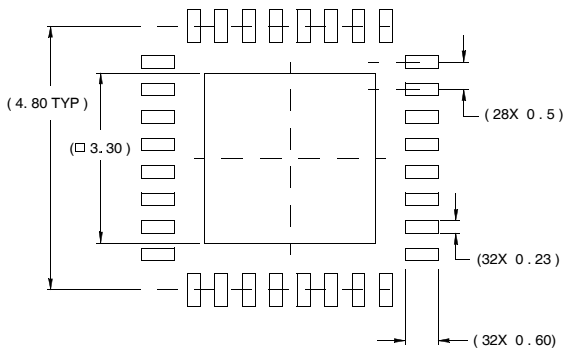

TYPICAL RECOMMENDED LAND PATTERN

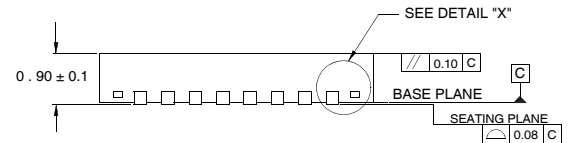

SIDE VIEW

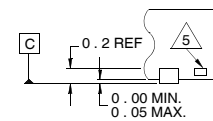

DETAIL "X"

NOTES:

1. Dimensions are in millimeters.  
Dimensions in ( ) for Reference Only.
2. Dimensioning and tolerancing conform to AMSE Y14.5m-1994.
3. Unless otherwise specified, tolerance : Decimal ± 0.05
4. Dimension b applies to the metallized terminal and is measured between 0.15mm and 0.30mm from the terminal tip.
5. Tiebar shown (if present) is a non-functional feature.
6. The configuration of the pin #1 identifier is optional, but must be located within the zone indicated. The pin #1 identifier may be either a mold or mark feature.

## Looking for pricing, stock, or lifecycle information?

Click below to explore more details on WIN SOURCE:

-  [View ISL4245EIRZ-T on WIN SOURCE](#)
-  [Renesas Electronics America](#) Information

## Optimize Your Supply Chain with WIN SOURCE Solutions

-  Global Sourcing Solution
-  Obsolete Management
-  Cost Control Management
-  Shortage Management
-  Alternative Solution
-  Excess Inventory Management