

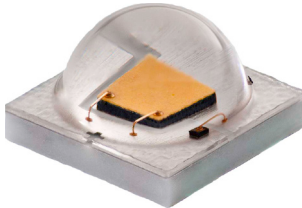

**THE DATASHEET OF  
XPEBTT-01-0000-00Y80**



# XLamp® XP-E2 Torch LEDs



## PRODUCT DESCRIPTION

The XLamp® XP-E2 Torch LED provides lumen output similar to the XLamp XP-G LED but in the smaller optical source of the XP-E2 LED. Together with a higher maximum current rating than XP-E2 and simplified color binning, the XLamp XP-E2 Torch LED is fully optimized for a wide range of mainstream portable lighting applications.

## FEATURES

- Available in cool white
- Binned at 25 °C
- Maximum drive current: 1.5 A
- Low thermal resistance: 5.8°C/W
- Wide viewing angle: 125°
- Unlimited floor life at ≤ 30 °C/85% RH
- Reflow solderable - JEDEC J-STD-020C compatible
- Electrically neutral thermal path
- RoHS compliant

## TABLE OF CONTENTS

Characteristics .....	2
Flux Characteristics .....	2
Relative Spectral Power Distribution .....	3
Relative Flux vs. Junction Temperature.....	3
Electrical Characteristics.....	4
Relative Flux vs. Current .....	4
Typical Spatial Distribution.....	5
Thermal Design .....	5
Performance Groups - Brightness .....	6
Performance Groups - Chromaticity .....	6
ANSI White Bin Plotted on the 1931 CIE	
Color Space .....	6
Bin and Order Code Formats.....	7
Reflow Soldering Characteristics.....	8
Notes .....	9
Mechanical Dimensions .....	10
Tape and Reel.....	12
Packaging.....	14



## CHARACTERISTICS

Characteristics	Unit	Minimum	Typical	Maximum
Thermal resistance, junction to solder point <sup>9</sup>	°C/W		5.8	
Viewing angle (FWHM)	degrees		125	
Temperature coefficient of voltage	mV/°C		-1.5	
ESD withstand voltage (HBM per Mil-Std-883D)			Class 3B	
DC forward current	mA			1500
Reverse voltage	V			1
Forward voltage (@ 1050 mA, 25 °C)	V		3.25	3.9
LED junction temperature	°C			150

### Note:

- Thermal resistance measurement was performed per the JEDEC JESD51-14 standard. See the [Thermal Resistance Measurement application note](#) for more details.

## FLUX CHARACTERISTICS (T<sub>J</sub> = 25 °C)

The following table provides order codes for XLamp XP-E2 Torch LEDs.

Color	CCT Range		Minimum Luminous Flux (lm) @ 1050 mA		Calculated Minimum Luminous Flux (lm) *	Order Code
	Min.	Max.	Group	Flux (lm)	1.5 A	
Cool White	6000 K	10,500 K	T6	280	357	XPEBTT-01-0000-00T80
			U2	300	382	XPEBTT-01-0000-00U80
			U3	320	407	XPEBTT-01-0000-00V80
			U4	340	433	XPEBTT-01-0000-00W80
			U5	360	458	XPEBTT-01-0000-00Y80

### Notes:

- Cree LED maintains a tolerance of ±7% on flux and power measurements, ±0.015 on chromaticity (CCx, CCy) measurements and ±2 on CRI measurements. See the Measurements section (page 9).
- Typical CRI for Cool White (6000 K – 10,500 K CCT) is 65.
- \* Calculated flux values at 1.5 A are for reference only.

RELATIVE SPECTRAL POWER DISTRIBUTION

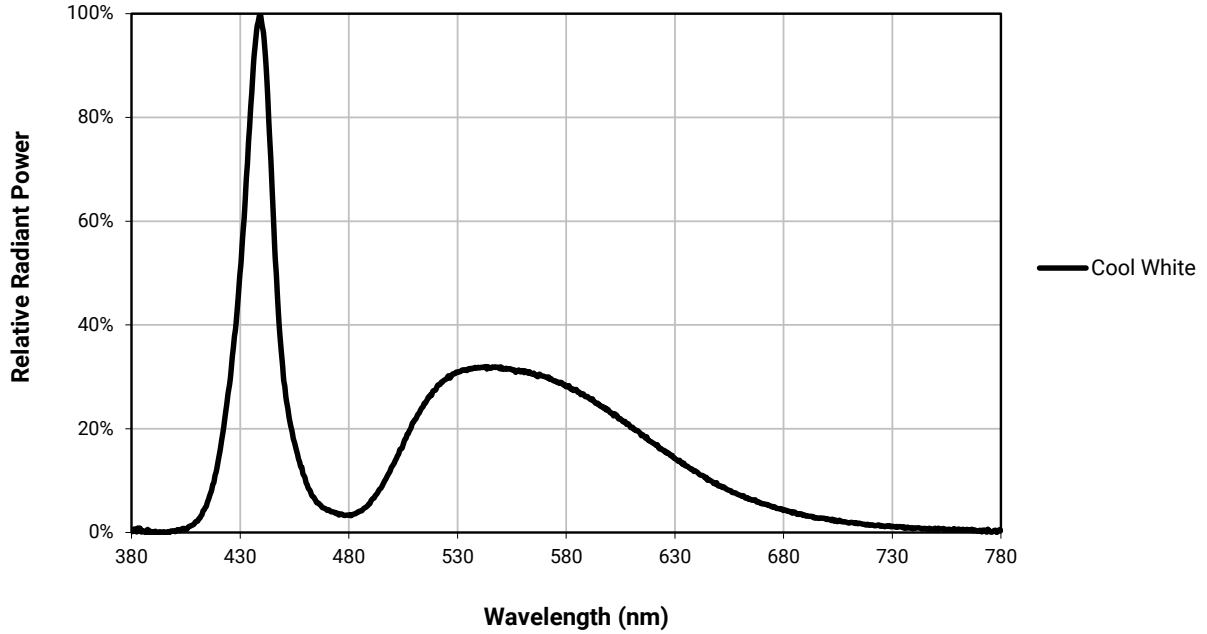

RELATIVE FLUX VS. JUNCTION TEMPERATURE ( $I_F = 1050 \text{ mA}$ )

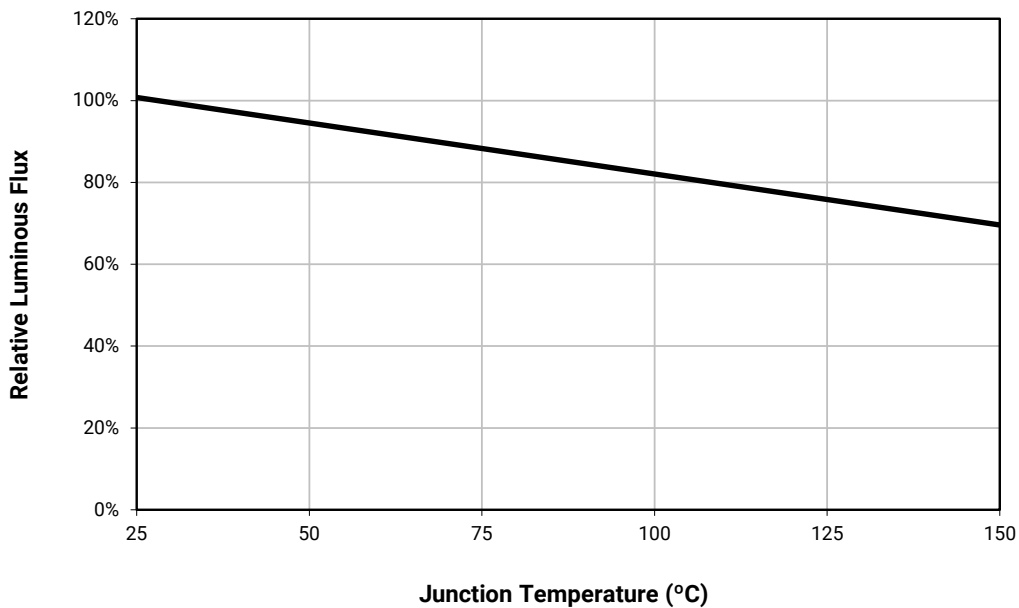

**ELECTRICAL CHARACTERISTICS ( $T_j = 25\text{ }^\circ\text{C}$ )**

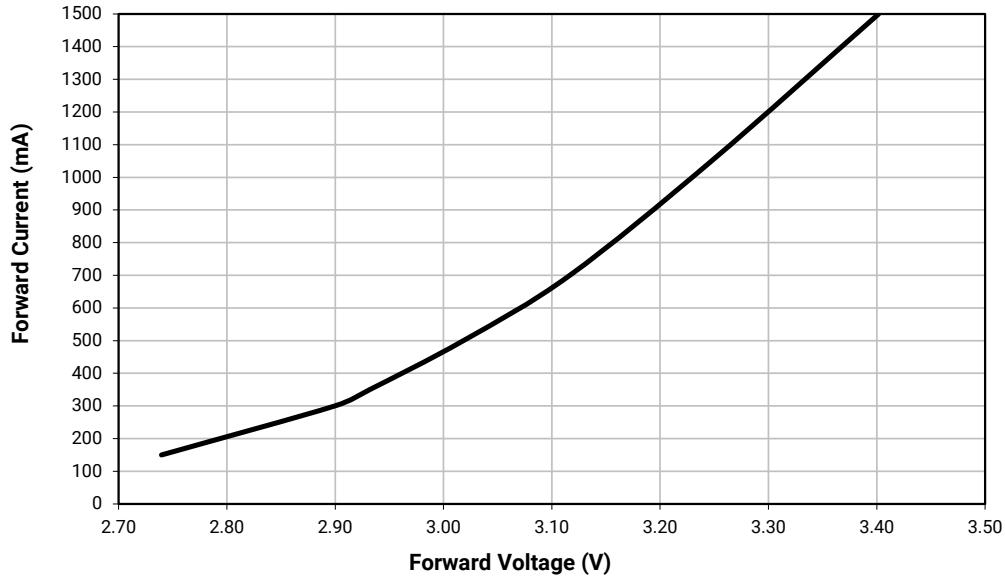

**RELATIVE FLUX VS. CURRENT ( $T_j = 25\text{ }^\circ\text{C}$ )**

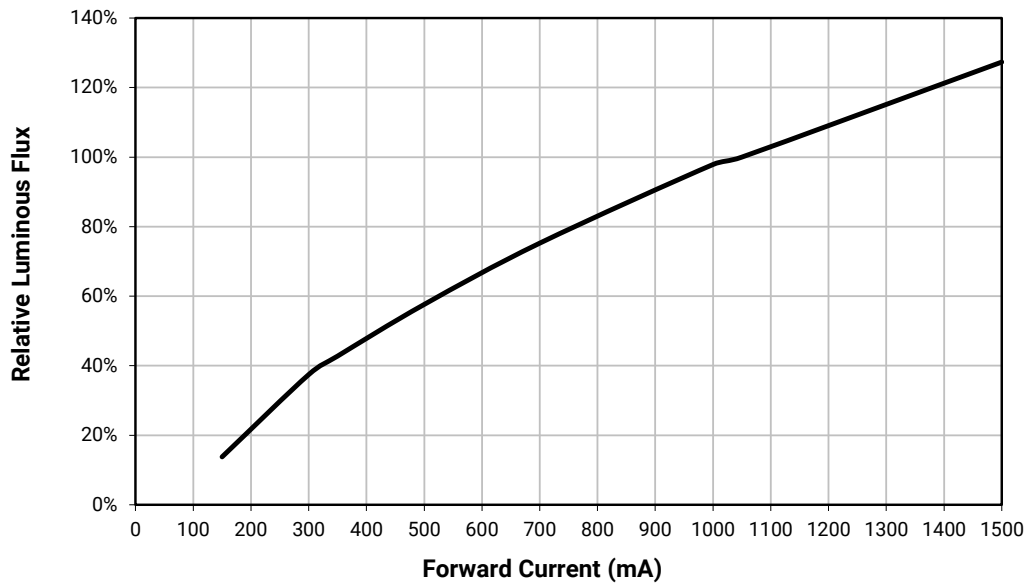

## TYPICAL SPATIAL DISTRIBUTION

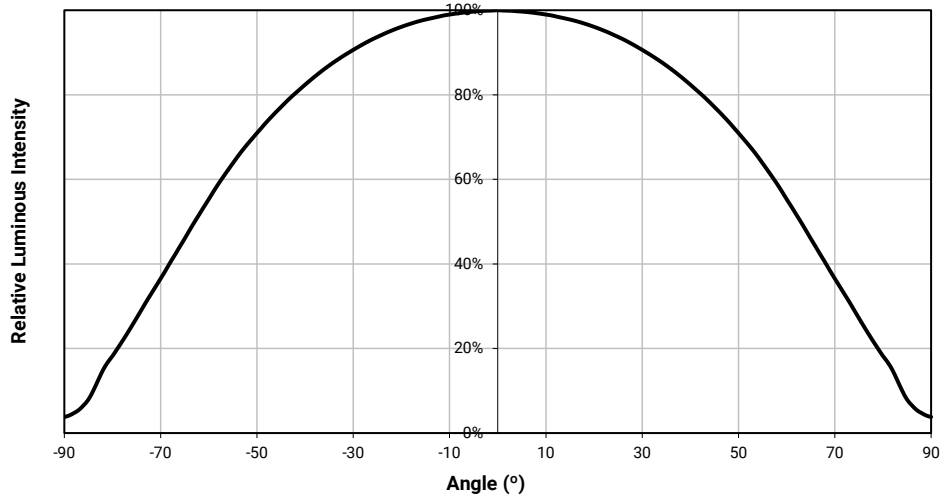

## THERMAL DESIGN

The maximum forward current is determined by the thermal resistance between the LED junction and ambient. It is crucial for the end product to be designed in a manner that minimizes the thermal resistance from the solder point to ambient in order to optimize lamp life and optical characteristics.

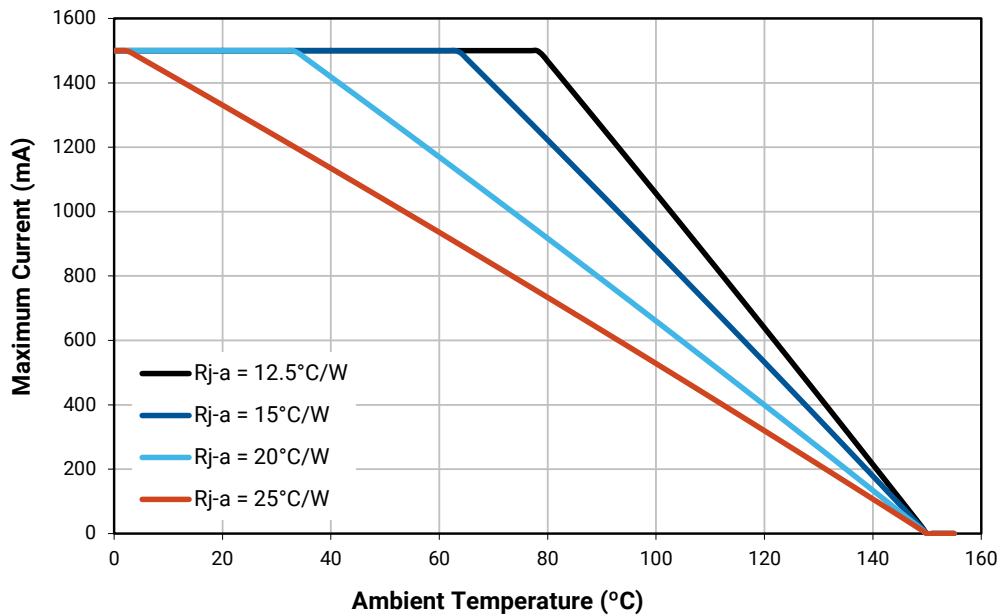

### PERFORMANCE GROUPS - BRIGHTNESS ( $T_j = 25\text{ }^\circ\text{C}$ )

XLamp XP-E2 Torch LEDs are tested for luminous flux and placed into one of the following bins.

Group Code	Minimum Luminous Flux	Maximum Luminous Flux
T6	280	300
U2	300	320
U3	320	340
U4	340	360
U5	360	380

### PERFORMANCE GROUPS - CHROMATICITY ( $T_j = 25\text{ }^\circ\text{C}$ )

XLamp XP-E2 Torch LEDs are tested for chromaticity and placed into the bin defined by the following bounding coordinates.

Bin	x	y
T1	0.302	0.33
	0.318	0.33
	0.295	0.28
	0.282	0.28

### ANSI WHITE BIN PLOTTED ON THE 1931 CIE COLOR SPACE ( $T_j = 25\text{ }^\circ\text{C}$ )

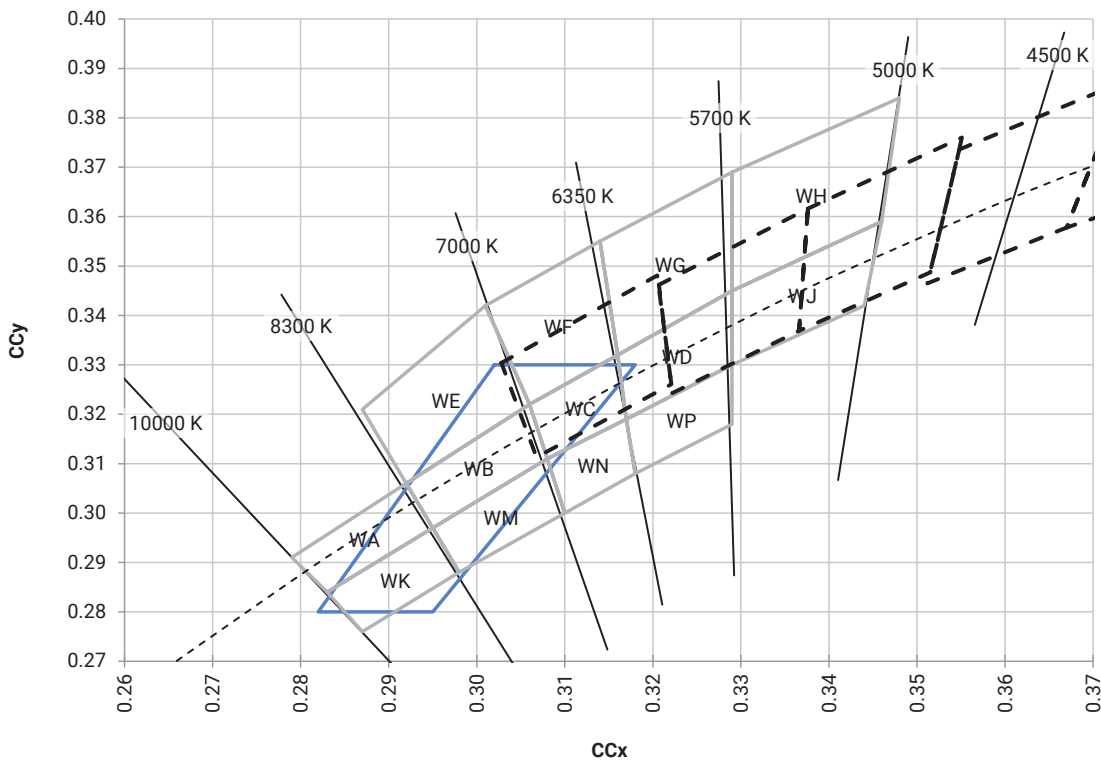

## BIN AND ORDER CODE FORMATS

Bin codes and order codes are configured as follows.

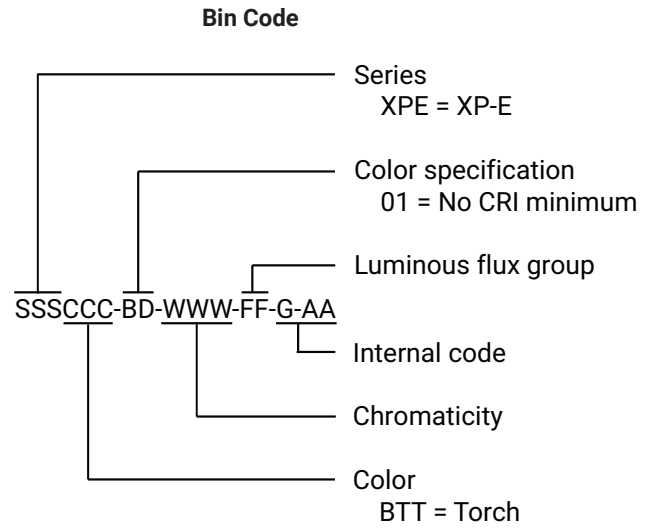
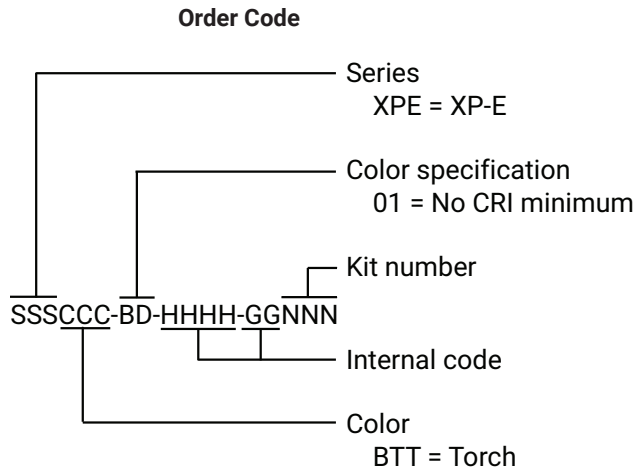

## REFLOW SOLDERING CHARACTERISTICS

In testing, Cree LED has found XLamp XP-E2 Torch LEDs to be compatible with JEDEC J-STD-020C, using the parameters listed below. As a general guideline, Cree LED recommends that users follow the recommended soldering profile provided by the manufacturer of the solder paste used, and therefore it is the lamp or luminaire manufacturer’s responsibility to determine applicable soldering requirements.

Note that this general guideline may not apply to all PCB designs and configurations of reflow soldering equipment.

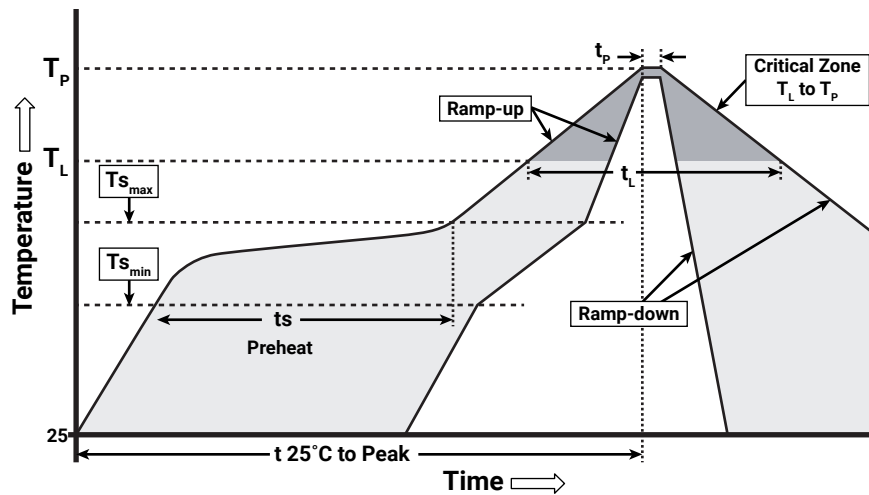

IPC/JEDEC J-STD-020C

Profile Feature	Lead-Free Solder
Average Ramp-Up Rate ( $T_{s_{max}}$ to $T_p$ )	1.2 °C/second
Preheat: Temperature Min ( $T_{s_{min}}$ )	120 °C
Preheat: Temperature Max ( $T_{s_{max}}$ )	170 °C
Preheat: Time ( $t_{s_{min}}$ to $t_{s_{max}}$ )	65-150 seconds
Time Maintained Above: Temperature ( $T_L$ )	217 °C
Time Maintained Above: Time ( $t_L$ )	45-90 seconds
Peak/Classification Temperature ( $T_p$ )	235 - 245 °C
Time Within 5 °C of Actual Peak Temperature ( $t_p$ )	20-40 seconds
Ramp-Down Rate	1 - 6 °C/second
Time 25 °C to Peak Temperature	4 minutes max.

Note: All temperatures refer to topside of the package, measured on the package body surface.

## NOTES

---

### Measurements

The luminous flux, radiant power, chromaticity, forward voltage and CRI measurements in this document are binning specifications only and solely represent product measurements as of the date of shipment. These measurements will change over time based on a number of factors that are not within Cree LED's control and are not intended or provided as operational specifications for the products. Calculated values are provided for informational purposes only and are not intended or provided as specifications.

### Pre-Release Qualification Testing

Please read the [LED Reliability Overview](#) for details of the qualification process Cree LED applies to ensure long-term reliability for XLamp LEDs and details of Cree LED's pre-release qualification testing for XLamp LEDs.

### Moisture Sensitivity

Cree LED recommends keeping XLamp LEDs in the provided, resealable moisture-barrier packaging (MBP) until immediately prior to soldering. Unopened MBPs that contain XLamp LEDs do not need special storage for moisture sensitivity.

Once the MBP is opened, XLamp XP-E2 Torch LEDs may be stored as MSL 1 per JEDEC J-STD-033, meaning they have unlimited floor life in conditions of  $\leq 30$  °C/85% relative humidity (RH). Regardless of the storage condition, Cree LED recommends sealing any unsoldered LEDs in the original MBP.

### RoHS Compliance

The levels of RoHS restricted materials in this product are below the maximum concentration values (also referred to as the threshold limits) permitted for such substances, or are used in an exempted application, in accordance with EU Directive 2011/65/EC (RoHS2), as implemented January 2, 2013. RoHS Declarations for this product can be obtained from your Cree LED representative or from the [Product Ecology](#) section of the Cree LED website.

### Vision Advisory

**WARNING:** Do not look at an exposed lamp in operation. Eye injury can result. For more information about LEDs and eye safety, please refer to the [LED Eye Safety application note](#).

**MECHANICAL DIMENSIONS**

Thermal vias, if present, are not shown on these drawings.  
 All measurements are ±.13 mm unless otherwise indicated.

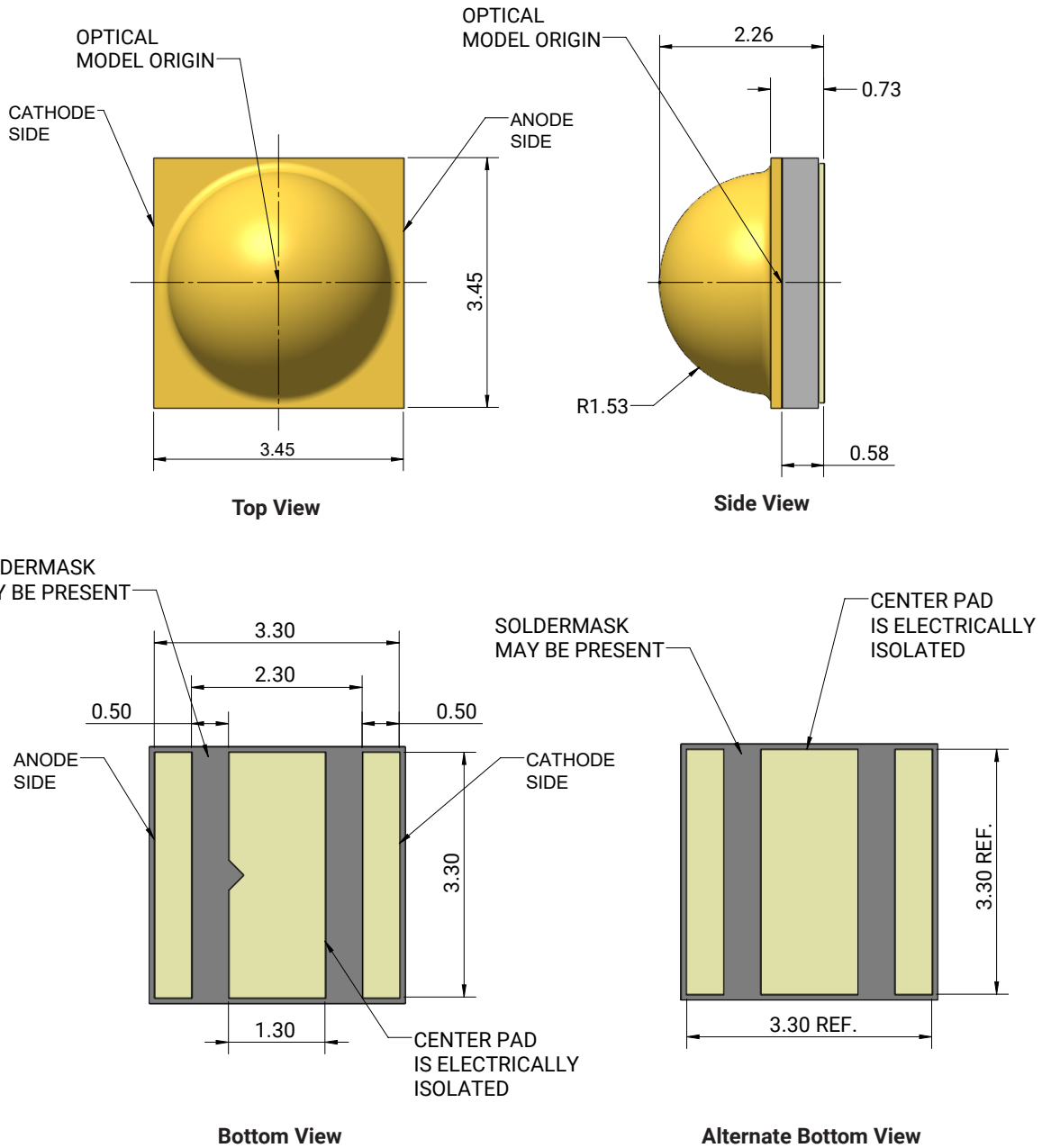

MECHANICAL DIMENSIONS - CONTINUED

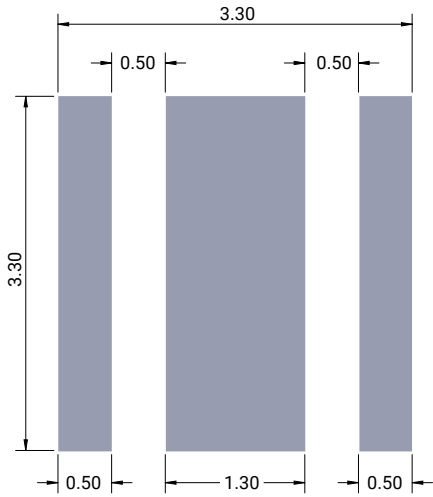

Recommended PCB Footprint

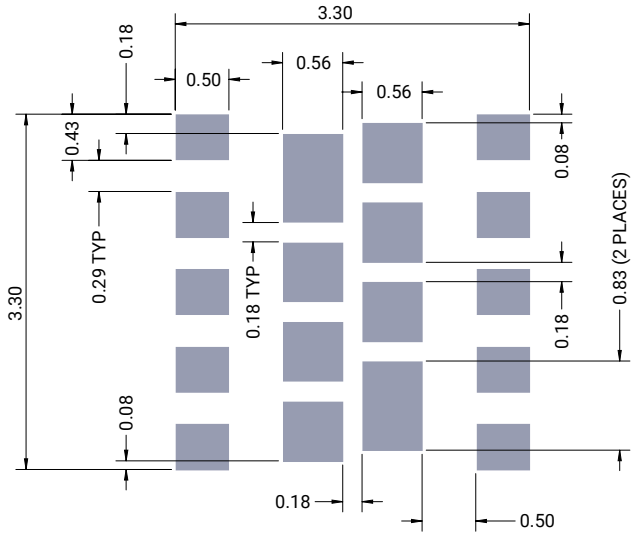

Recommended Stencil Opening

**TAPE AND REEL**

All Cree LED carrier tapes conform to EIA-481D, Automated Component Handling Systems Standard.

All dimensions in mm.

All measurements are  $\pm 0.15$  mm unless otherwise indicated.

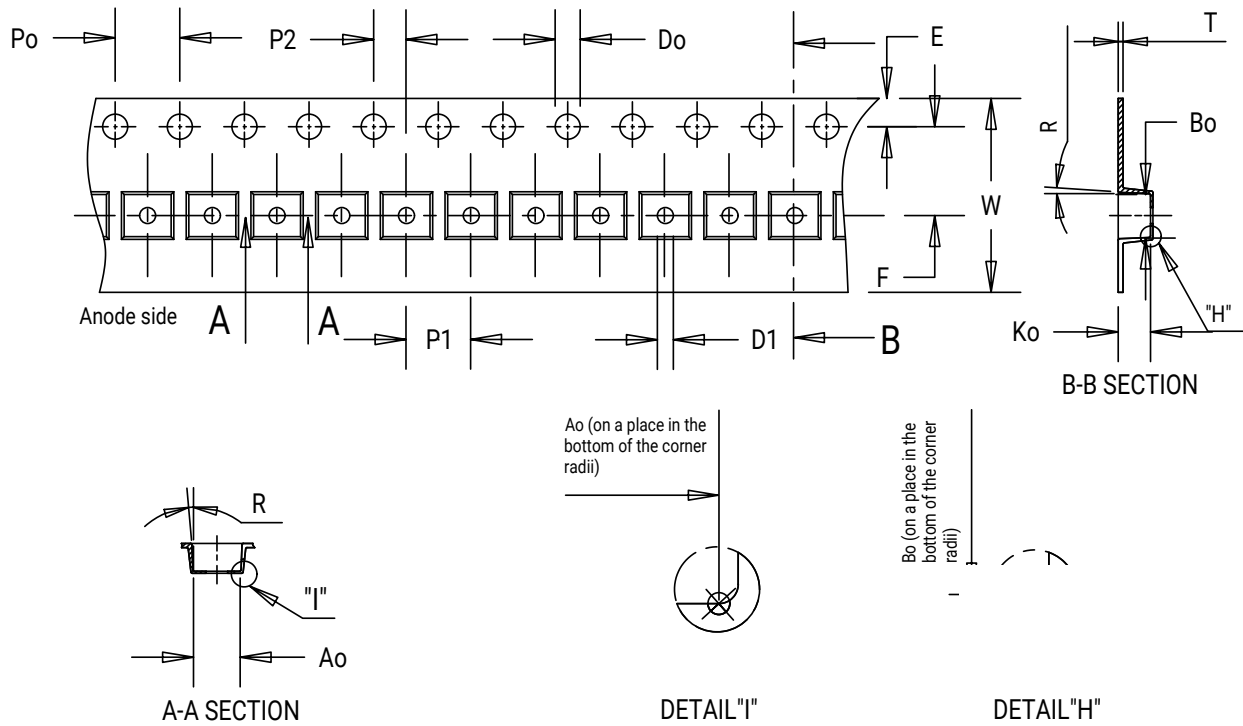

Item	Ao	Bo	Ko	Po	P1	P2	T	E	F	Do	D1	W	R
Dim.	3.70	3.70	2.40	4.00	8.00	2.00	0.30	1.75	5.50	1.55	1.50	12.00	5°

**TAPE AND REEL - CONTINUED**

All Cree LED carrier tapes conform to EIA-481D, Automated Component Handling Systems Standard.

All dimensions in mm.

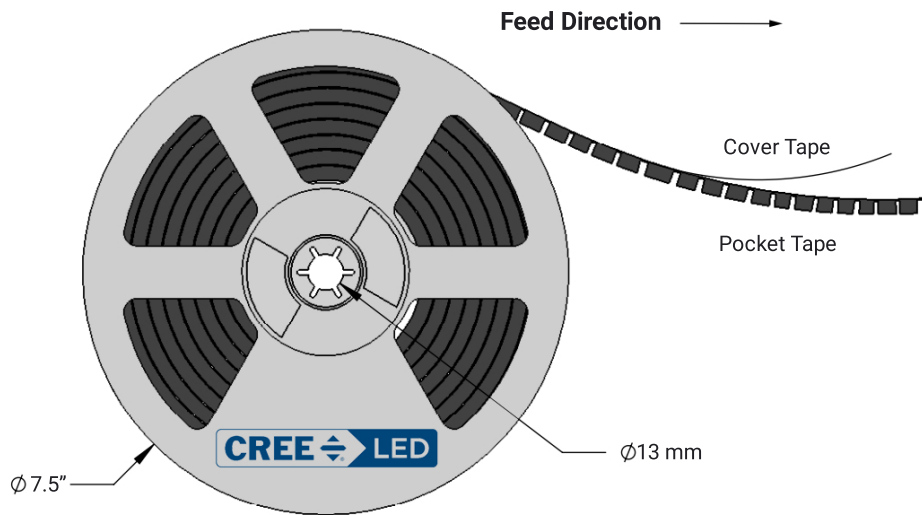
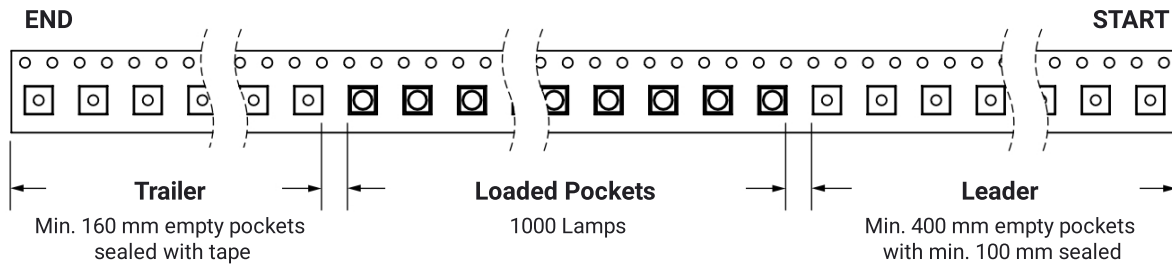

PACKAGING

**Unpackaged Reel**

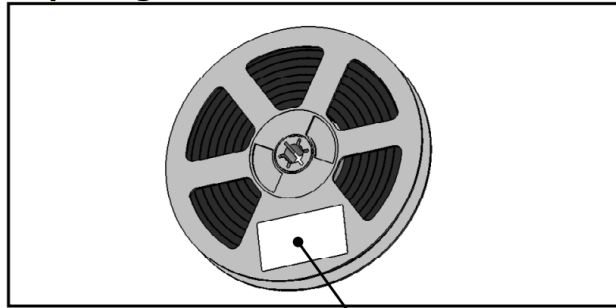

Label with Cree LED Bin Code, Quantity, Reel ID

**Packaged Reel**

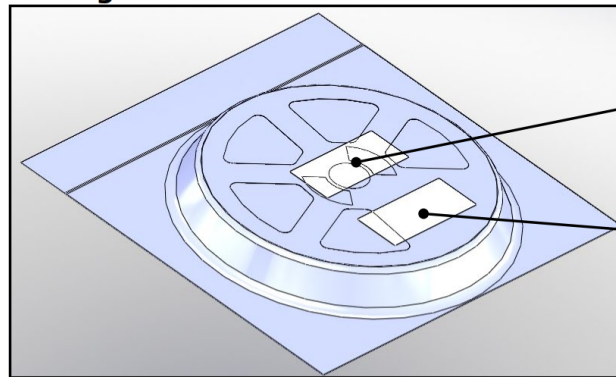

Label with Cree LED Order Code, Quantity, Reel ID, PO#

Label with Cree LED Bin Code, Quantity, Reel ID

**Boxed Reel**

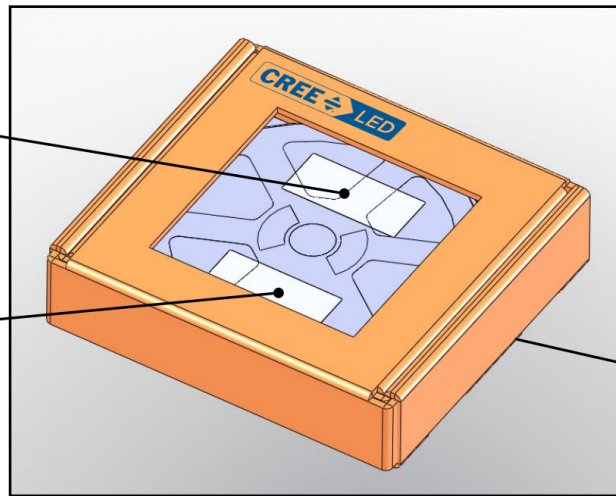



Label with Cree LED Order Code, Quantity, Reel ID, PO#

Label with Cree LED Bin Code, Quantity, Reel ID

Patent Label (on bottom of box)

## Looking for pricing, stock, or lifecycle information?

Click below to explore more details on WIN SOURCE:

-  [View XPEBTT-01-0000-00Y80 on WIN SOURCE](#)
-  [CreeLED, Inc. Information](#)

## Optimize Your Supply Chain with WIN SOURCE Solutions

-  Global Sourcing Solution
-  Obsolete Management
-  Cost Control Management
-  Shortage Management
-  Alternative Solution
-  Excess Inventory Management