



**THE DATASHEET OF
ESP32-PICO-MINI-02U-N8R2**



ESP32-PICO-MINI-02

ESP32-PICO-MINI-02U

Datasheet

2.4 GHz Wi-Fi + Bluetooth® + Bluetooth LE module

Built around ESP32 series of SoCs, Xtensa® dual-core 32-bit LX6 microprocessor

Flash up to 8 MB, PSRAM up to 2 MB

27 GPIOs, rich set of peripherals

On-board PCB antenna or external antenna connector



ESP32-PICO-MINI-02



ESP32-PICO-MINI-02U



Version 1.3

Espressif Systems

Copyright © 2023

1 Module Overview

Note:

Check the link or the QR code to make sure that you use the latest version of this document:
https://espressif.com/sites/default/files/documentation/esp32-pico-mini-02_datasheet_en.pdf



1.1 Features

CPU and On-Chip Memory

- ESP32-PICO-V3-02 embedded, Xtensa dual-core 32-bit LX6 microprocessor, up to 240 MHz
- 448 KB ROM for booting and core functions
- 520 KB SRAM for data and instructions
- 16 KB SRAM in RTC
- 8 MB SPI flash
- 2 MB PSRAM

Wi-Fi

- 802.11b/g/n
- Bit rate: 802.11n up to 150 Mbps
- A-MPDU and A-MSDU aggregation
- 0.4 μ s guard interval support
- Center frequency range of operating channel: 2412 ~ 2484 MHz

Bluetooth

- Bluetooth V4.2 BR/EDR and Bluetooth LE specification
- Class-1, class-2 and class-3 transmitter
- AFH
- CVSD and SBC

Peripherals

- SD card, UART, SPI, SDIO, I2C, LED PWM, Motor PWM, I2S, IR, pulse counter, GPIO, capacitive touch sensor, ADC, DAC, TWAI[®] (compatible with ISO 11898-1, i.e. CAN Specification 2.0), Ethernet MAC

Integrated Components on Module

- 40 MHz crystal oscillator

Antenna Options

- ESP32-PICO-MINI-02: On-board PCB antenna
- ESP32-PICO-MINI-02U: external antenna via a connector

Operating Conditions

- Operating voltage/Power supply: 3.0 ~ 3.6 V
- Operating ambient temperature: -40 ~ 85 °C

Certification

- RF certification: See certificates for [ESP32-PICO-MINI-02](#) and [ESP32-PICO-MINI-02U](#)
- Green certification: REACH/RoHS

Test

- Reliability: HTOL/HTSL/uHAST/TCT/ESD

1.2 Description

ESP32-PICO-MINI-02 and ESP32-PICO-MINI-02U are two general-purpose Wi-Fi + Bluetooth + Bluetooth LE MCU modules. They are based on ESP32-PICO-V3-02, a System-in-Package (SiP) device, which integrates an 8 MB SPI flash, 2 MB SPI Pseudo static RAM (PSRAM) and 40 MHz crystal oscillator. The rich set of peripherals and a small size make the two modules an ideal choice for a wide variety of IoT applications, ranging from home automation, smart building, consumer electronics to industrial control, and they are suitable for intelligent speakers, speech recognition toys, intelligent gateway and Ethernet, etc.

ESP32-PICO-MINI-02 comes with a PCB antenna. ESP32-PICO-MINI-02U comes with a connector for an external antenna. The ordering information of the two modules is listed as follows:

Table 1: Ordering Information

Module	Ordering Code	Chip embedded	Module dimensions (mm)
ESP32-PICO-MINI-02	ESP32-PICO-MINI-02-N8R2	ESP32-PICO-V3-02	13.2 × 16.6 × 2.4
ESP32-PICO-MINI-02U	ESP32-PICO-MINI-02U-N8R2	ESP32-PICO-V3-02	13.2 × 11.2 × 2.4

At the core of ESP32-PICO-MINI-02 and ESP32-PICO-MINI-02U is the ESP32-PICO-V3-02 sip*. The chip embedded is designed to be scalable and adaptive. There are two CPU cores that can be individually controlled, and the CPU clock frequency is adjustable from 80 MHz to 240 MHz. The chip also has a low-power coprocessor that can be used instead of the CPU to save power while performing tasks that do not require much computing power, such as monitoring of peripherals. This ESP32 chip integrates a rich set of peripherals, ranging from SD card interface, capacitive touch sensors, ADC, DAC, Two-Wire Automotive Interface, to Ethernet, high-speed SPI, UART, I2S, I2C, etc.

Note:

* For details on the part numbers of the ESP32 family of chips, please refer to the document [ESP32 Series Datasheet](#).

1.3 Applications

- Generic Low-power IoT Sensor Hub
- Generic Low-power IoT Data Loggers
- Cameras for Video Streaming
- Over-the-top (OTT) Devices
- Speech Recognition
- Image Recognition
- Mesh Network
- Home Automation
- Smart Building
- Industrial Automation
- Smart Agriculture
- Audio Applications
- Health Care Applications
- Wi-Fi-enabled Toys
- Wearable Electronics
- Retail & Catering Applications

Contents

1	Module Overview	2
1.1	Features	2
1.2	Description	3
1.3	Applications	3
2	Block Diagram	8
3	Pin Definitions	9
3.1	Pin Layout	9
3.2	Pin Description	10
3.3	Strapping Pins	11
4	Electrical Characteristics	14
4.1	Absolute Maximum Ratings	14
4.2	Recommended Operating Conditions	14
4.3	DC Characteristics (3.3 V, 25 °C)	14
4.4	Current Consumption Characteristics	15
4.5	Wi-Fi RF Characteristics	16
4.5.1	Wi-Fi RF Standards	16
4.5.2	Transmitter Characteristics	16
4.5.3	Receiver Characteristics	17
4.6	Bluetooth Radio	18
4.6.1	Receiver – Basic Data Rate	18
4.6.2	Transmitter – Basic Data Rate	19
4.6.3	Receiver – Enhanced Data Rate	19
4.6.4	Transmitter – Enhanced Data Rate	20
4.7	Bluetooth LE Radio	20
4.7.1	Receiver	20
4.7.2	Transmitter	21
5	Module Schematics	22
6	Peripheral Schematics	24
7	Physical Dimensions and PCB Land Pattern	25
7.1	Physical Dimensions	25
7.2	Recommended PCB Land Pattern	26
7.3	Dimensions of External Antenna Connector	27
8	Product Handling	29
8.1	Storage Conditions	29
8.2	Electrostatic Discharge (ESD)	29
8.3	Reflow Profile	29

8.4	Ultrasonic Vibration	30
9	Related Documentation and Resources	31
	Revision History	32

List of Tables

1	Ordering Information	3
2	Pin Definitions	10
3	Strapping Pins	12
4	Parameter Descriptions of Setup and Hold Times for the Strapping Pins	13
5	Absolute Maximum Ratings	14
6	Recommended Operating Conditions	14
7	DC Characteristics (3.3 V, 25 °C)	14
8	Current Consumption Depending on RF Modes	15
9	Current Consumption Depending on Work Modes	16
10	Wi-Fi RF Standards	16
11	TX Power Characteristics	17
12	RX Sensitivity Characteristics	17
13	RX Maximum Input Level	18
14	Adjacent Channel Rejection	18
15	Receiver Characteristics – Basic Data Rate	18
16	Transmitter Characteristics – Basic Data Rate	19
17	Receiver Characteristics – Enhanced Data Rate	19
18	Transmitter Characteristics – Enhanced Data Rate	20
19	Receiver Characteristics – BLE	21
20	Transmitter Characteristics – BLE	21

List of Figures

1	ESP32-PICO-MINI-02 Block Diagram	8
2	ESP32-PICO-MINI-02U Block Diagram	8
3	ESP32-PICO-MINI-02 Pin Layout (Top View)	9
4	ESP32-PICO-MINI-02U Pin Layout (Top View)	10
5	Setup and Hold Times for the Strapping Pins	13
6	ESP32-PICO-MINI-02 Schematics	22
7	ESP32-PICO-MINI-02U Schematics	23
8	Peripheral Schematics	24
9	ESP32-PICO-MINI-02 Physical Dimensions	25
10	ESP32-PICO-MINI-02U Physical Dimensions	25
11	ESP32-PICO-MINI-02 Recommended PCB Land Pattern	26
12	ESP32-PICO-MINI-02U Recommended PCB Land Pattern	27
13	Dimensions of External Antenna Connector	28
14	Reflow Profile	29

2 Block Diagram

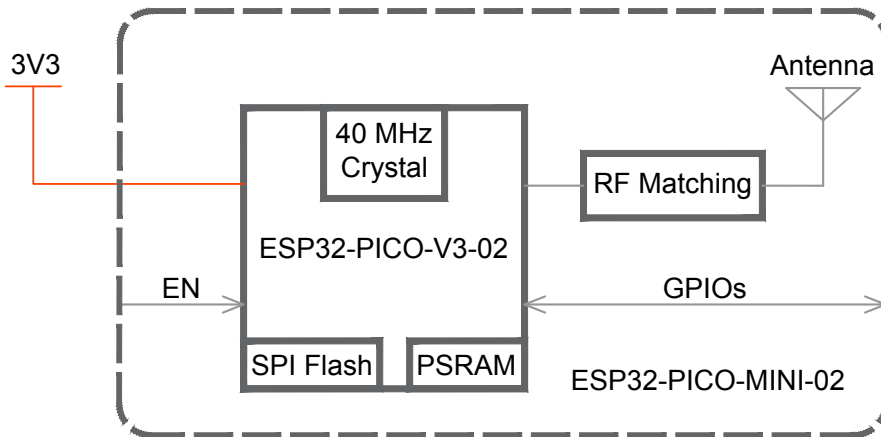

Figure 1: ESP32-PICO-MINI-02 Block Diagram

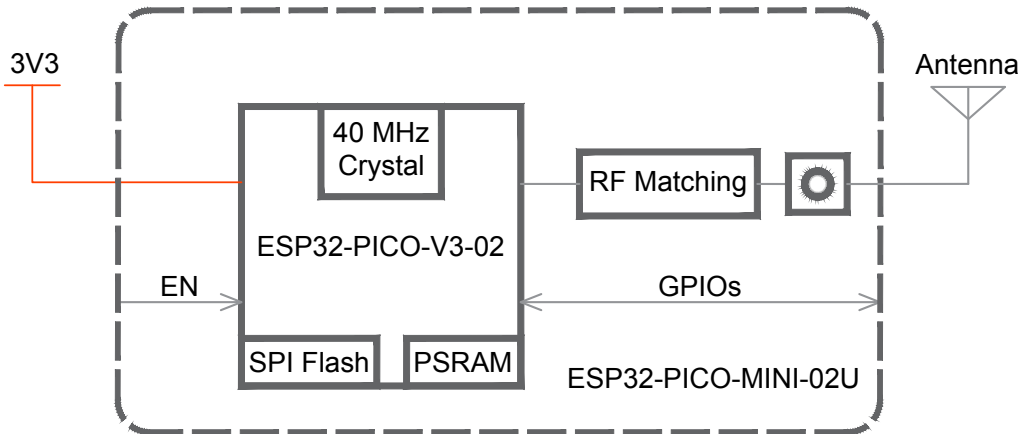

Figure 2: ESP32-PICO-MINI-02U Block Diagram

3 Pin Definitions

3.1 Pin Layout

The pin diagram below shows the approximate location of pins on the module. For the actual diagram drawn to scale, please refer to Figure 7.1 *Physical Dimensions*.

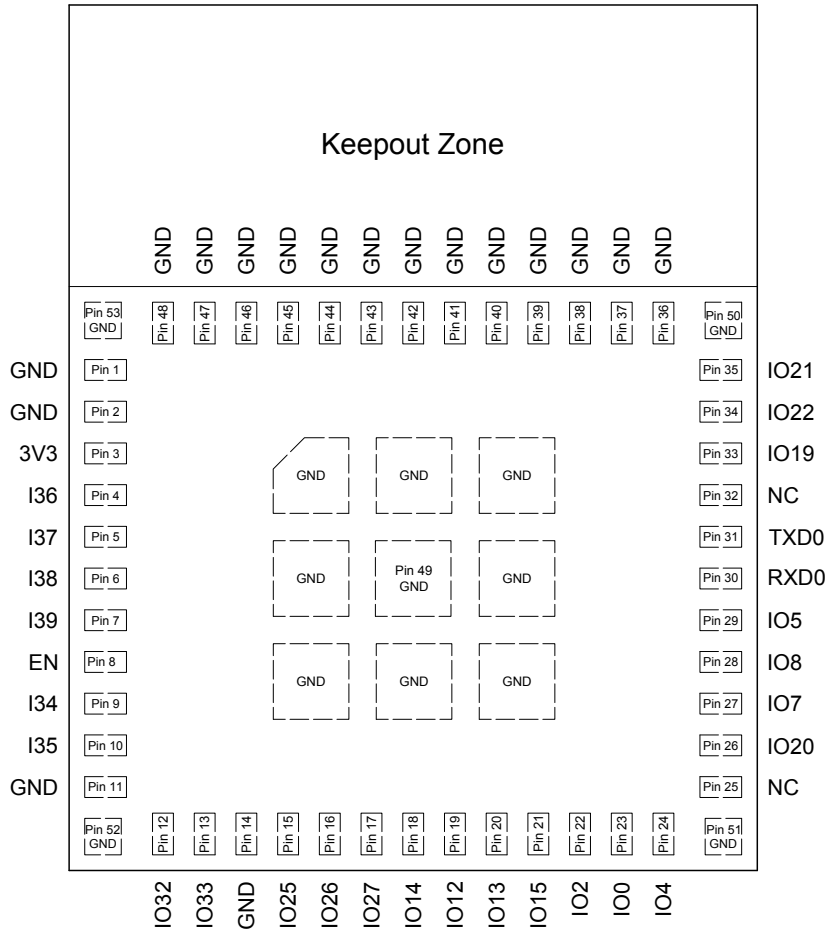

Figure 3: ESP32-PICO-MINI-02 Pin Layout (Top View)

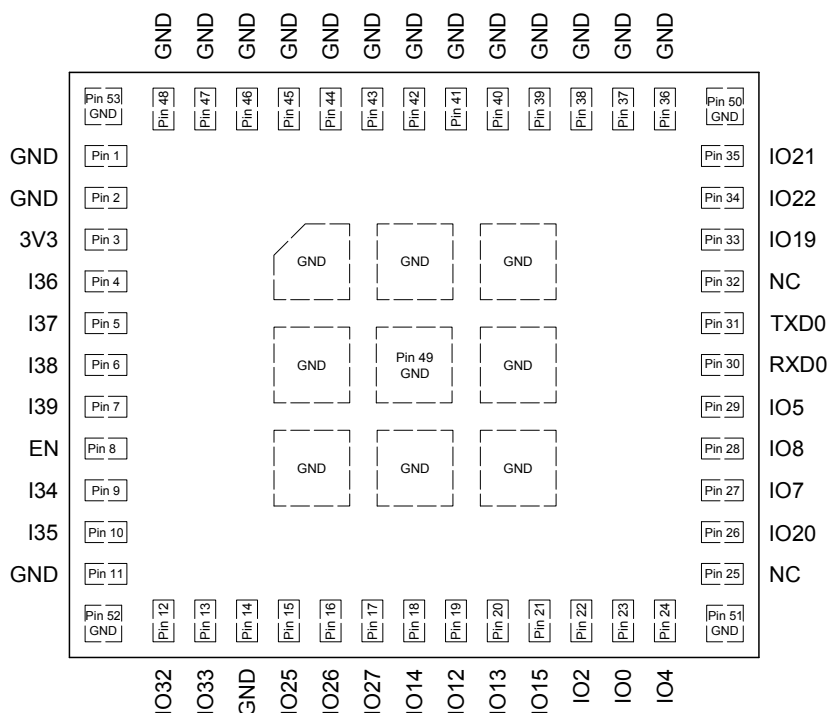

Figure 4: ESP32-PICO-MINI-02U Pin Layout (Top View)

3.2 Pin Description

ESP32-PICO-MINI-02 and ESP32-PICO-MINI-02U each has 53 pins. See pin definitions in Table 2.

For peripheral pin configurations, please refer to [ESP32 Series Datasheet](#).

Table 2: Pin Definitions

Name	No.	Type ¹	Function
GND	1, 2, 11, 14, 36-53	P	Ground
3V3	3	P	Power supply
I36	4	I	GPIO36, ADC1_CH0, RTC_GPIO0
I37	5	I	GPIO37, ADC1_CH1, RTC_GPIO1
I38	6	I	GPIO38, ADC1_CH2, RTC_GPIO2
I39	7	I	GPIO39, ADC1_CH3, RTC_GPIO3
EN	8	I	High: On; enables the chip Low: Off; the chip shuts down Note: Do not leave EN pin floating.
I34	9	I	GPIO34, ADC1_CH6, RTC_GPIO4
I35	10	I	GPIO35, ADC1_CH7, RTC_GPIO5
IO32	12	I/O	GPIO32, XTAL_32K_P (32.768 kHz crystal oscillator input), ADC1_CH4, TOUCH9, RTC_GPIO9
IO33	13	I/O	GPIO33, XTAL_32K_N (32.768 kHz crystal oscillator output), ADC1_CH5, TOUCH8, RTC_GPIO8
IO25	15	I/O	GPIO25, DAC_1, ADC2_CH8, RTC_GPIO6, EMAC_RXD0
IO26	16	I/O	GPIO26, DAC_2, ADC2_CH9, RTC_GPIO7, EMAC_RXD1

Cont'd on next page

Table 2 – cont'd from previous page

Name	No.	Type ¹	Function
IO27	17	I/O	GPIO27, ADC2_CH7, TOUCH7, RTC_GPIO17, EMAC_RX_DV
IO14	18	I/O	GPIO14, ADC2_CH6, TOUCH6, RTC_GPIO16, MTMS, HSPICLK, HS2_CLK, SD_CLK, EMAC_TXD2
IO12	19	I/O	GPIO12, ADC2_CH5, TOUCH5, RTC_GPIO15, MTDI, HSPIQ, HS2_DATA2, SD_DATA2, EMAC_TXD3
IO13	20	I/O	GPIO13, ADC2_CH4, TOUCH4, RTC_GPIO14, MTCK, HSPID, HS2_DATA3, SD_DATA3, EMAC_RX_ER
IO15	21	I/O	GPIO15, ADC2_CH3, TOUCH3, RTC_GPIO13, MTDO, HSPICS0, HS2_CMD, SD_CMD, EMAC_RXD3
IO2	22	I/O	GPIO2, ADC2_CH2, TOUCH2, RTC_GPIO12, HSPiWP, HS2_DATA0, SD_DATA0
IO0	23	I/O	GPIO0, ADC2_CH1, TOUCH1, RTC_GPIO11, CLK_OUT1, EMAC_TX_CLK
IO4	24	I/O	GPIO4, ADC2_CH0, TOUCH0, RTC_GPIO10, HSPiHD, HS2_DATA1, SD_DATA1, EMAC_TX_ER
NC	25	-	-
IO20	26	I/O	GPIO20
IO7	27	I/O	GPIO7, HS1_DATA0, U2RTS, SD_DATA0
IO8	28	I/O	GPIO8, HS1_DATA1, U2CTS, SD_DATA1
IO5	29	I/O	GPIO5, VSPICS0, HS1_DATA6, EMAC_RX_CLK
RXD0	30	I/O	GPIO3, U0RXD, CLK_OUT2
TXD0	31	I/O	GPIO1, U0TXD, CLK_OUT3, EMAC_RXD2
NC	32	-	-
IO19	33	I/O	GPIO19, VSPIQ, U0CTS, EMAC_TXD0
IO22	34	I/O	GPIO22, VSPIWP, U0RTS, EMAC_TXD1
IO21	35	I/O	GPIO21, VSPIHD, EMAC_TX_EN

* P: power supply; I: input; O: output.

* Pins CMD/IO11 and CLK/IO6 are used for connecting the embedded flash, and pins SD2/IO9 and SD3/IO10 are used for connecting embedded PSRAM. These pins are not led out.

3.3 Strapping Pins

Note:

The content below is excerpted from Section Strapping Pins in [ESP32 Series Datasheet](#). For the strapping pin mapping between the chip and modules, please refer to Chapter 5 [Module Schematics](#).

ESP32 has five strapping pins:

- MTDI
- GPIO0
- GPIO2
- MTDO

- GPIO5

Software can read the values of these five bits from register "GPIO_STRAPPING".

During the chip's system reset release (power-on-reset, RTC watchdog reset and brownout reset), the latches of the strapping pins sample the voltage level as strapping bits of "0" or "1", and hold these bits until the chip is powered down or shut down. The strapping bits configure the device's boot mode, the operating voltage of VDD_SDIO and other initial system settings.

Each strapping pin is connected to its internal pull-up/pull-down during the chip reset. Consequently, if a strapping pin is unconnected or the connected external circuit is high-impedance, the internal weak pull-up/pull-down will determine the default input level of the strapping pins.

To change the strapping bit values, users can apply the external pull-down/pull-up resistances, or use the host MCU's GPIOs to control the voltage level of these pins when powering on ESP32.

After reset release, the strapping pins work as normal-function pins.

Refer to Table 3 for a detailed boot-mode configuration by strapping pins.

Table 3: Strapping Pins

Voltage of Internal LDO (VDD_SDIO)					
Pin	Default	3.3 V		1.8 V	
MTDI	Pull-down	0		1	
Bootling Mode					
Pin	Default	SPI Boot		Download Boot	
GPIO0	Pull-up	1		0	
GPIO2	Pull-down	Don't-care		0	
Enabling/Disabling Debugging Log Print over U0TXD During Bootling					
Pin	Default	U0TXD Active		U0TXD Silent	
MTDO	Pull-up	1		0	
Timing of SDIO Slave					
Pin	Default	FE Sampling FE Output	FE Sampling RE Output	RE Sampling FE Output	RE Sampling RE Output
MTDO	Pull-up	0	0	1	1
GPIO5	Pull-up	0	1	0	1

* FE: falling-edge, RE: rising-edge

* Firmware can configure register bits to change the settings of "Voltage of Internal LDO (VDD_SDIO)" and "Timing of SDIO Slave", after bootling.

* The module integrates a 3.3 V SPI flash, so the pin MTDI cannot be set to 1 when the module is powered up.

The illustration below shows the setup and hold times for the strapping pins before and after the CHIP_PU signal goes high. Details about the parameters are listed in Table 4.

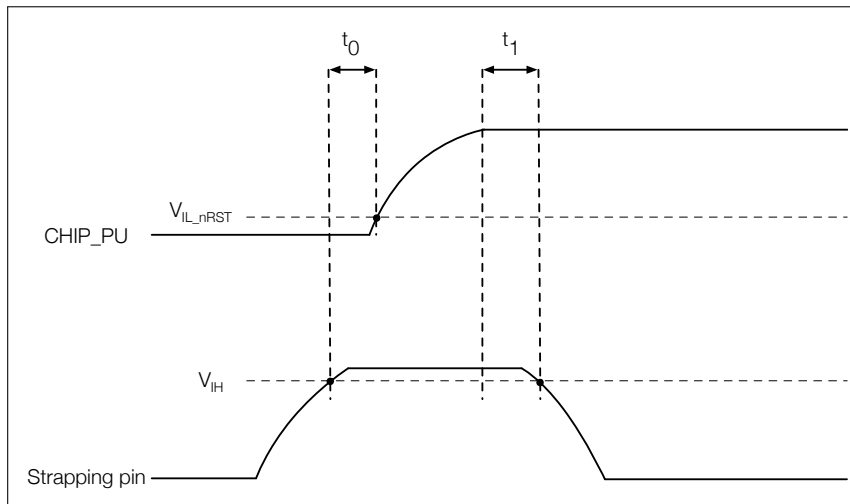

Figure 5: Setup and Hold Times for the Strapping Pins

Table 4: Parameter Descriptions of Setup and Hold Times for the Strapping Pins

Parameters	Description	Min.	Unit
t_0	Setup time before CHIP_PU goes from low to high	0	ms
t_1	Hold time after CHIP_PU goes high	1	ms

4 Electrical Characteristics

4.1 Absolute Maximum Ratings

Stresses above those listed in *Absolute Maximum Ratings* may cause permanent damage to the device. These are stress ratings only and functional operation of the device at these or any other conditions beyond those indicated under *Recommended Operating Conditions* is not implied. Exposure to absolute-maximum-rated conditions for extended periods may affect device reliability.

Table 5: Absolute Maximum Ratings

Symbol	Parameter	Min	Max	Unit
VDD33	Power supply voltage	-0.3	3.6	V
T _{STORE}	Storage temperature	-40	85	°C

* Please see Appendix IO MUX of [ESP32 Series Datasheet](#) for IO's power domain.

4.2 Recommended Operating Conditions

Table 6: Recommended Operating Conditions

Symbol	Parameter	Min	Typ	Max	Unit
VDD33	Power supply voltage	3.0	3.3	3.6	V
I _{VDD}	Current delivered by external power supply	0.5	—	—	A
T	Operating ambient temperature	-40	—	85	°C

4.3 DC Characteristics (3.3 V, 25 °C)

Table 7: DC Characteristics (3.3 V, 25 °C)

Symbol	Parameter	Min	Typ	Max	Unit
C _{IN}	Pin capacitance	—	2	—	pF
V _{IH}	High-level input voltage	0.75 × VDD ¹	—	VDD ¹ + 0.3	V
V _{IL}	Low-level input voltage	-0.3	—	0.25 × VDD ¹	V
I _{IH}	High-level input current	—	—	50	nA
I _{IL}	Low-level input current	—	—	50	nA
V _{OH}	High-level output voltage	0.8 × VDD ¹	—	—	V
V _{OL}	Low-level output voltage	—	—	0.1 × VDD ¹	V

Cont'd on next page

Table 7 – cont'd from previous page

Symbol	Parameter	Min	Typ	Max	Unit	
I_{OH}	High-level source current ($V_{DD}^1 = 3.3\text{ V}$, $V_{OH} \geq 2.64\text{ V}$, output drive strength set to the maximum)	VDD3P3_CPU power domain ^{1,2}	—	40	—	mA
		VDD3P3_RTC power domain ^{1,2}	—	40	—	mA
		VDD_SDIO power domain ^{1,3}	—	20	—	mA
I_{OL}	Low-level sink current ($V_{DD}^1 = 3.3\text{ V}$, $V_{OL} = 0.495\text{ V}$, output drive strength set to the maximum)	—	28	—	mA	
R_{PU}	Resistance of internal pull-up resistor	—	45	—	k Ω	
R_{PD}	Resistance of internal pull-down resistor	—	45	—	k Ω	
V_{IL_nRST}	Low-level input voltage of CHIP_PU to shut down the chip	—	—	0.6	V	

¹ Please see Appendix IO MUX of [ESP32 Series Datasheet](#) for IO's power domain. VDD is the I/O voltage for a particular power domain of pins.

² For VDD3P3_CPU and VDD3P3_RTC power domain, per-pin current sourced in the same domain is gradually reduced from around 40 mA to around 29 mA, $V_{OH} \geq 2.64\text{ V}$, as the number of current-source pins increases.

³ Pins occupied by flash and/or PSRAM in the VDD_SDIO power domain were excluded from the test.

4.4 Current Consumption Characteristics

Owing to the use of advanced power-management technologies, the module can switch between different power modes. For details on different power modes, please refer to Section *RTC and Low-Power Management* in [ESP32 Series Datasheet](#).

Table 8: Current Consumption Depending on RF Modes

Work mode	Description	Peak (mA)	
Active (RF working)	TX	802.11b, 20 MHz, 1 Mbps, @19.5 dBm	368
		802.11g, 20 MHz, 54 Mbps, @14 dBm	258
		802.11n, 20 MHz, MCS7, @13 dBm	248
		802.11n, 40 MHz, MCS7, @13 dBm	250
	RX ²	802.11b/g/n, 20 MHz	111
		802.11n, 40 MHz	117

¹ The current consumption measurements are taken with a 3.3 V supply at 25 °C of ambient temperature at the RF port. All transmitters' measurements are based on a 100% duty cycle.

² The current consumption figures for in RX mode are for cases when the peripherals are disabled and the CPU idle.

Table 9: Current Consumption Depending on Work Modes

Work mode	Description		Current consumption (Typ)
Modem-sleep ^{1, 2}	The CPU is powered on ³	240 MHz	30 ~ 68 mA
		160 MHz	27 ~ 44 mA
		Normal speed: 80 MHz	20 ~ 31 mA
Light-sleep	—		0.8 mA
Deep-sleep	The ULP coprocessor is powered up ⁴		150 μ A
	ULP sensor-monitored pattern ⁵		100 μ A @1% duty
	RTC timer + RTC memory		10 μ A
	RTC timer only		5 μ A
Power off	CHIP_PU is set to low level, the chip is powered down		1 μ A

¹ The current consumption figures in Modem-sleep mode are for cases where the CPU is powered up and the cache idle.

² When Wi-Fi is enabled, the chip switches between Active and Modem-sleep modes. Therefore, current consumption changes accordingly.

³ In Modem-sleep mode, the CPU frequency changes automatically. The frequency depends on the CPU load and the peripherals used.

⁴ During Deep-sleep, when the ULP coprocessor is powered up, peripherals such as GPIO and RTC I2C are able to operate.

⁵ The "ULP sensor-monitored pattern" refers to the mode where the ULP coprocessor or the sensor works periodically. When ADC works with a duty cycle of 1%, the typical current consumption is 100 μ A.

4.5 Wi-Fi RF Characteristics

4.5.1 Wi-Fi RF Standards

Table 10: Wi-Fi RF Standards

Name	Description	
Center frequency range of operating channel ¹	2412 ~ 2484 MHz	
Wi-Fi wireless standard	IEEE 802.11b/g/n	
Data rate	20 MHz	11b: 1, 2, 5.5 and 11 Mbps 11g: 6, 9, 12, 18, 24, 36, 48, 54 Mbps 11n: MCS0-7, 72.2 Mbps (Max)
	40 MHz	11n: MCS0-7, 150 Mbps (Max)
Antenna type	PCB antenna, external antenna ²	

¹ Device should operate in the center frequency range allocated by regional regulatory authorities. Target center frequency range is configurable by software.

² For the modules that use external antennas, the output impedance is 50 Ω . For other modules without external antennas, the output impedance is irrelevant.

4.5.2 Transmitter Characteristics

Target TX power is configurable based on device or certification requirements. The default characteristics are provided in Table 11.

Table 11: TX Power Characteristics

Rate	Typ (dBm)
11b, 1 Mbps	19.5
11b, 11 Mbps	19.5
11g, 6 Mbps	18
11g, 54 Mbps	14
11n, HT20, MCS0	18
11n, HT20, MCS7	13
11n, HT40, MCS0	18
11n, HT40, MCS7	13

4.5.3 Receiver Characteristics

Table 12: RX Sensitivity Characteristics

Rate	Typ (dBm)
1 Mbps	-97
2 Mbps	-94
5.5 Mbps	-92
11 Mbps	-88
6 Mbps	-93
9 Mbps	-91
12 Mbps	-89
18 Mbps	-87
24 Mbps	-84
36 Mbps	-80
48 Mbps	-77
54 Mbps	-75
11n, HT20, MCS0	-92
11n, HT20, MCS1	-88
11n, HT20, MCS2	-86
11n, HT20, MCS3	-83
11n, HT20, MCS4	-80
11n, HT20, MCS5	-76
11n, HT20, MCS6	-74
11n, HT20, MCS7	-72
11n, HT40, MCS0	-89
11n, HT40, MCS1	-85
11n, HT40, MCS2	-83
11n, HT40, MCS3	-80
11n, HT40, MCS4	-76
11n, HT40, MCS5	-72
11n, HT40, MCS6	-71

Cont'd on next page

Table 12 – cont'd from previous page

Rate	Typ (dBm)
11n, HT40, MCS7	-69

Table 13: RX Maximum Input Level

Rate	Typ (dBm)
11b, 1 Mbps	5
11b, 11 Mbps	5
11g, 6 Mbps	0
11g, 54 Mbps	-8
11n, HT20, MCS0	0
11n, HT20, MCS7	-8
11n, HT40, MCS0	0
11n, HT40, MCS7	-8

Table 14: Adjacent Channel Rejection

Rate	Typ (dB)
11b, 11 Mbps	35
11g, 6 Mbps	27
11g, 54 Mbps	13
11n, HT20, MCS0	27
11n, HT20, MCS7	12
11n, HT40, MCS0	16
11n, HT40, MCS7	7

4.6 Bluetooth Radio

4.6.1 Receiver – Basic Data Rate

Table 15: Receiver Characteristics – Basic Data Rate

Parameter	Conditions	Min	Typ	Max	Unit
Sensitivity @0.1% BER	—	-90	-89	-88	dBm
Maximum received signal @0.1% BER	—	0	—	—	dBm
Co-channel C/I	—	—	+7	—	dB
Adjacent channel selectivity C/I	F = F0 + 1 MHz	—	—	-6	dB
	F = F0 - 1 MHz	—	—	-6	dB
	F = F0 + 2 MHz	—	—	-25	dB
	F = F0 - 2 MHz	—	—	-33	dB
	F = F0 + 3 MHz	—	—	-25	dB
	F = F0 - 3 MHz	—	—	-45	dB

Cont'd on next page

Table 15 – cont'd from previous page

Parameter	Conditions	Min	Typ	Max	Unit
Out-of-band blocking performance	30 MHz ~ 2000 MHz	-10	—	—	dBm
	2000 MHz ~ 2400 MHz	-27	—	—	dBm
	2500 MHz ~ 3000 MHz	-27	—	—	dBm
	3000 MHz ~ 12.5 GHz	-10	—	—	dBm
Intermodulation	—	-36	—	—	dBm

4.6.2 Transmitter – Basic Data Rate

Table 16: Transmitter Characteristics – Basic Data Rate

Parameter	Conditions	Min	Typ	Max	Unit
RF transmit power*	-	-	0	-	dBm
Gain control step	-	-	3	-	dB
RF power control range	-	-12	-	+9	dBm
+20 dB bandwidth	-	-	0.9	-	MHz
Adjacent channel transmit power	F = F0 ± 2 MHz	-	-55	-	dBm
	F = F0 ± 3 MHz	-	-55	-	dBm
	F = F0 ± > 3 MHz	-	-59	-	dBm
Δf_{1avg}	-	-	-	155	kHz
Δf_{2max}	-	127	-	-	kHz
$\Delta f_{2avg}/\Delta f_{1avg}$	-	-	0.92	-	-
ICFT	-	-	-7	-	kHz
Drift rate	-	-	0.7	-	kHz/50 μ s
Drift (DH1)	-	-	6	-	kHz
Drift (DH5)	-	-	6	-	kHz

* There are a total of eight power levels from 0 to 7, and the transmit power ranges from -12 dBm to 9 dBm. When the power level rises by 1, the transmit power increases by 3 dB. Power level 4 is used by default and the corresponding transmit power is 0 dBm.

4.6.3 Receiver – Enhanced Data Rate

Table 17: Receiver Characteristics – Enhanced Data Rate

Parameter	Conditions	Min	Typ	Max	Unit
$\pi/4$ DQPSK					
Sensitivity @0.01% BER	—	-90	-89	-88	dBm
Maximum received signal @0.01% BER	—	—	0	—	dBm
Co-channel C/I	—	—	11	—	dB
Adjacent channel selectivity C/I	F = F0 + 1 MHz	—	-7	—	dB
	F = F0 - 1 MHz	—	-7	—	dB
	F = F0 + 2 MHz	—	-25	—	dB
	F = F0 - 2 MHz	—	-35	—	dB

Cont'd on next page

Table 17 – cont'd from previous page

Parameter	Conditions	Min	Typ	Max	Unit
	F = F0 + 3 MHz	—	-25	—	dB
	F = F0 - 3 MHz	—	-45	—	dB
8DPSK					
Sensitivity @0.01% BER	—	-84	-83	-82	dBm
Maximum received signal @0.01% BER	—	—	-5	—	dBm
C/I c-channel	—	—	18	—	dB
Adjacent channel selectivity C/I	F = F0 + 1 MHz	—	2	—	dB
	F = F0 - 1 MHz	—	2	—	dB
	F = F0 + 2 MHz	—	-25	—	dB
	F = F0 - 2 MHz	—	-25	—	dB
	F = F0 + 3 MHz	—	-25	—	dB
	F = F0 - 3 MHz	—	-38	—	dB

4.6.4 Transmitter – Enhanced Data Rate

Table 18: Transmitter Characteristics – Enhanced Data Rate

Parameter	Conditions	Min	Typ	Max	Unit
RF transmit power (see note under Table 16)	—	—	0	—	dBm
Gain control step	—	—	3	—	dB
RF power control range	—	-12	—	+9	dBm
$\pi/4$ DQPSK max w0	—	—	-0.72	—	kHz
$\pi/4$ DQPSK max wi	—	—	-6	—	kHz
$\pi/4$ DQPSK max wi + w0	—	—	-7.42	—	kHz
8DPSK max w0	—	—	0.7	—	kHz
8DPSK max wi	—	—	-9.6	—	kHz
8DPSK max wi + w0	—	—	-10	—	kHz
$\pi/4$ DQPSK modulation accuracy	RMS DEVM	—	4.28	—	%
	99% DEVM	—	100	—	%
	Peak DEVM	—	13.3	—	%
8 DPSK modulation accuracy	RMS DEVM	—	5.8	—	%
	99% DEVM	—	100	—	%
	Peak DEVM	—	14	—	%
In-band spurious emissions	F = F0 \pm 1 MHz	—	-46	—	dBm
	F = F0 \pm 2 MHz	—	-44	—	dBm
	F = F0 \pm 3 MHz	—	-49	—	dBm
	F = F0 +/- > 3 MHz	—	—	-53	dBm
EDR differential phase coding	—	—	100	—	%

4.7 Bluetooth LE Radio

4.7.1 Receiver

Table 19: Receiver Characteristics – BLE

Parameter	Conditions	Min	Typ	Max	Unit
Sensitivity @30.8% PER	—	-94	-93	-92	dBm
Maximum received signal @30.8% PER	—	0	—	—	dBm
Co-channel C/I	—	—	+10	—	dB
Adjacent channel selectivity C/I	F = F0 + 1 MHz	—	-5	—	dB
	F = F0 - 1 MHz	—	-5	—	dB
	F = F0 + 2 MHz	—	-25	—	dB
	F = F0 - 2 MHz	—	-35	—	dB
	F = F0 + 3 MHz	—	-25	—	dB
	F = F0 - 3 MHz	—	-45	—	dB
Out-of-band blocking performance	30 MHz ~ 2000 MHz	-10	—	—	dBm
	2000 MHz ~ 2400 MHz	-27	—	—	dBm
	2500 MHz ~ 3000 MHz	-27	—	—	dBm
	3000 MHz ~ 12.5 GHz	-10	—	—	dBm
Intermodulation	—	-36	—	—	dBm

4.7.2 Transmitter

Table 20: Transmitter Characteristics – BLE

Parameter	Conditions	Min	Typ	Max	Unit
RF transmit power (see note under Table 16)	—	—	0	—	dBm
Gain control step	—	—	3	—	dB
RF power control range	—	-12	—	+9	dBm
Adjacent channel transmit power	F = F0 ± 2 MHz	—	-52	—	dBm
	F = F0 ± 3 MHz	—	-58	—	dBm
	F = F0 ± > 3 MHz	—	-60	—	dBm
$\Delta f_{1\text{avg}}$	—	—	—	265	kHz
$\Delta f_{2\text{max}}$	—	247	—	—	kHz
$\Delta f_{2\text{avg}}/\Delta f_{1\text{avg}}$	—	—	+0.92	—	—
ICFT	—	—	-10	—	kHz
Drift rate	—	—	0.7	—	kHz/50 μ s
Drift	—	—	2	—	kHz

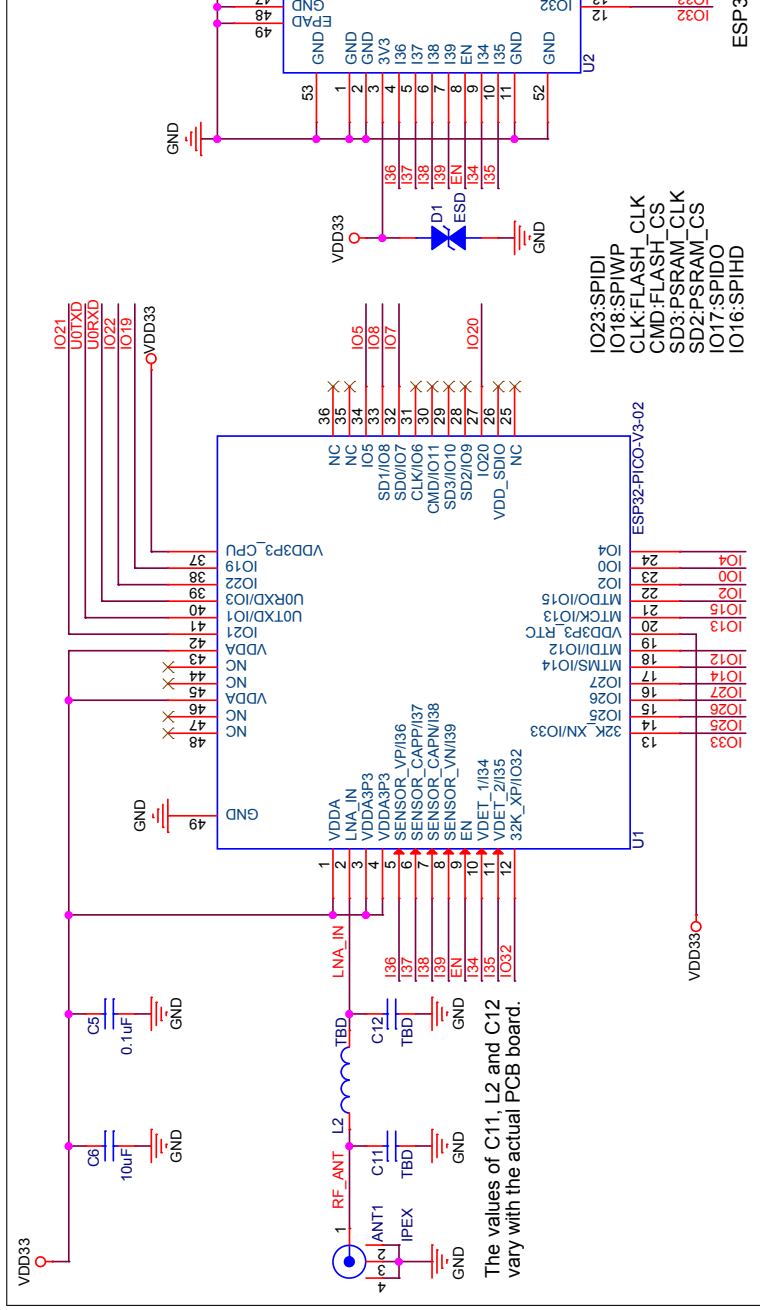

Figure 7: ESP32-PICO-MINI-02U Schematics

6 Peripheral Schematics

This is the typical application circuit of the module connected with peripheral components (for example, power supply, antenna, reset button, JTAG interface, and UART interface).

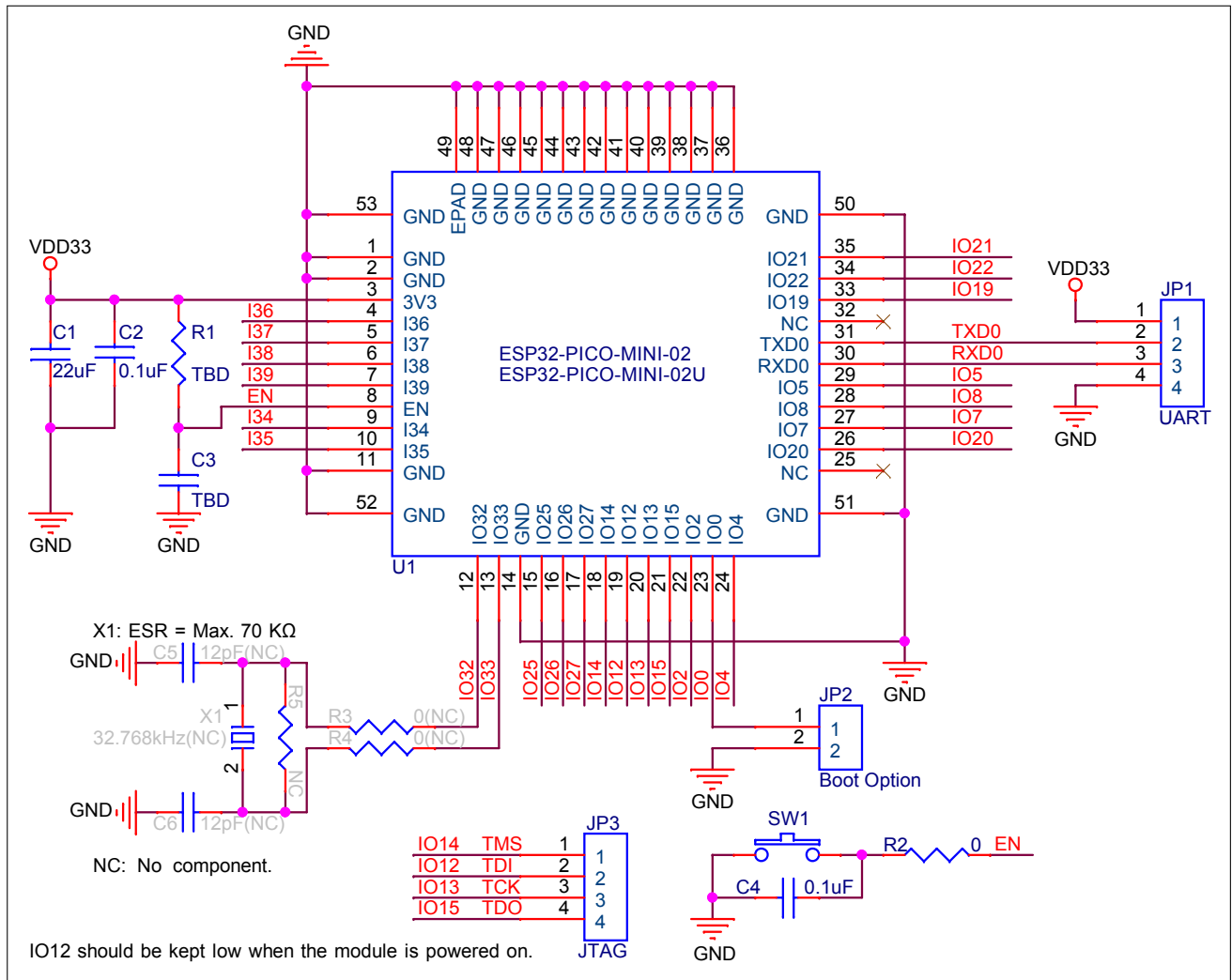

Figure 8: Peripheral Schematics

- Soldering EPAD Pin 49 to the ground of the base board is not a must. If you choose to solder it, please apply the correct amount of soldering paste. Too much soldering paste may increase the gap between the module and the baseboard. As a result, the adhesion between other pins and the baseboard may be poor.
- To ensure that the power supply to the ESP32 chip is stable during power-up, it is advised to add an RC delay circuit at the EN pin. The recommended setting for the RC delay circuit is usually $R = 10\text{ k}\Omega$ and $C = 1\text{ }\mu\text{F}$. However, specific parameters should be adjusted based on the power-up timing of the module and the power-up and reset sequence timing of the chip. For ESP32's power-up and reset sequence timing diagram, please refer to Section *Power Scheme* in [ESP32 Series Datasheet](#).

7 Physical Dimensions and PCB Land Pattern

7.1 Physical Dimensions

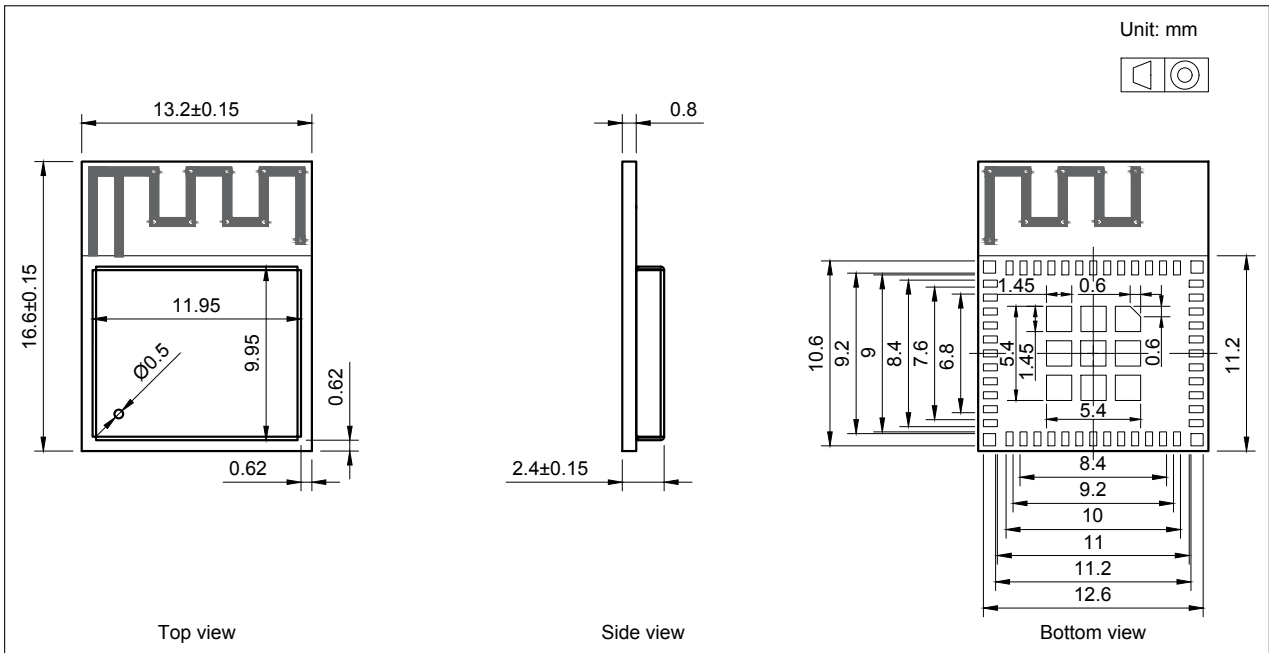

Figure 9: ESP32-PICO-MINI-02 Physical Dimensions

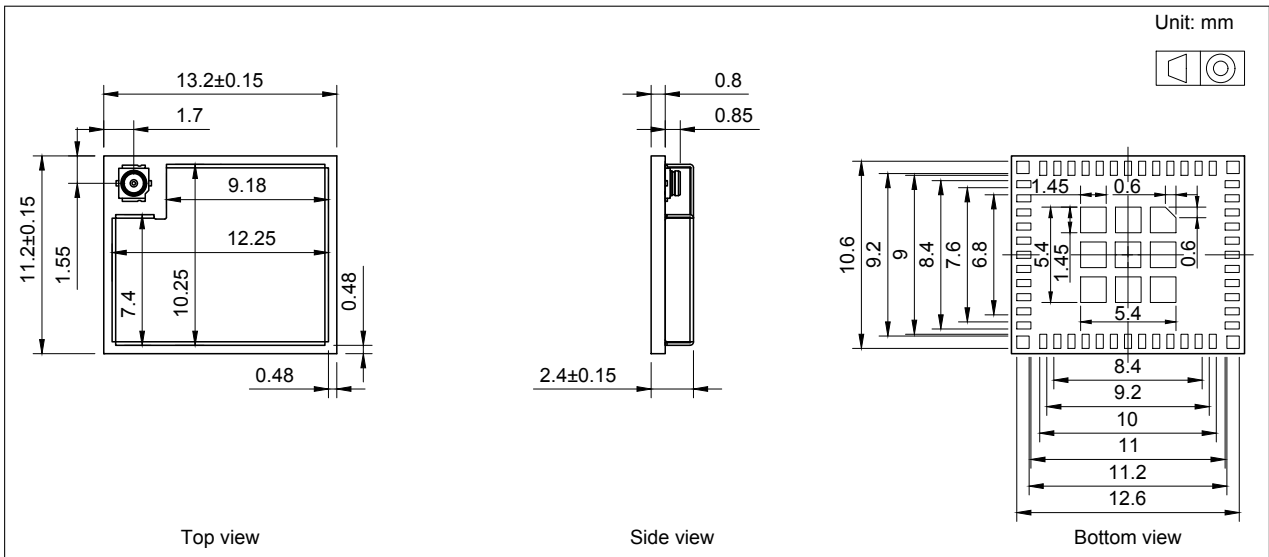

Figure 10: ESP32-PICO-MINI-02U Physical Dimensions

Note:

For information about tape, reel, and product marking, please refer to [Espressif Module Package Information](#).

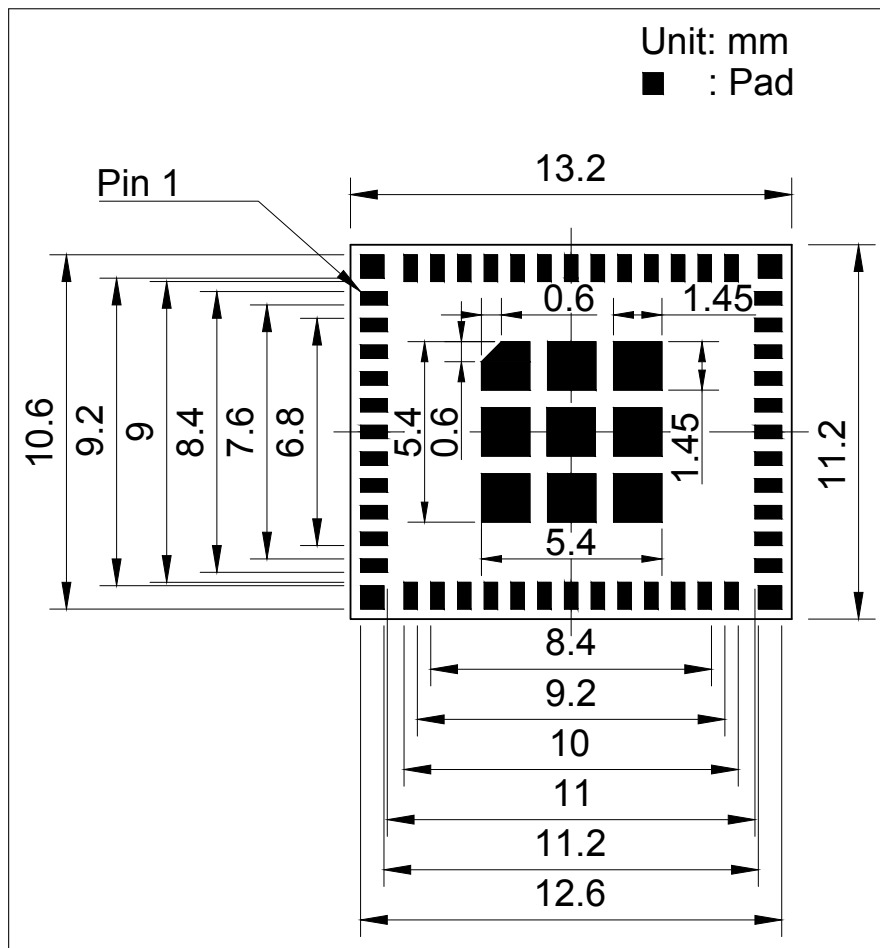

Figure 12: ESP32-PICO-MINI-02U Recommended PCB Land Pattern

7.3 Dimensions of External Antenna Connector

ESP32-PICO-MINI-02U uses the third generation external antenna connector as shown in Figure 13. This connector is compatible with the following connectors:

- W.FL Series connector from Hirose
- MHF III connector from I-PEX
- AMMC connector from Amphenol

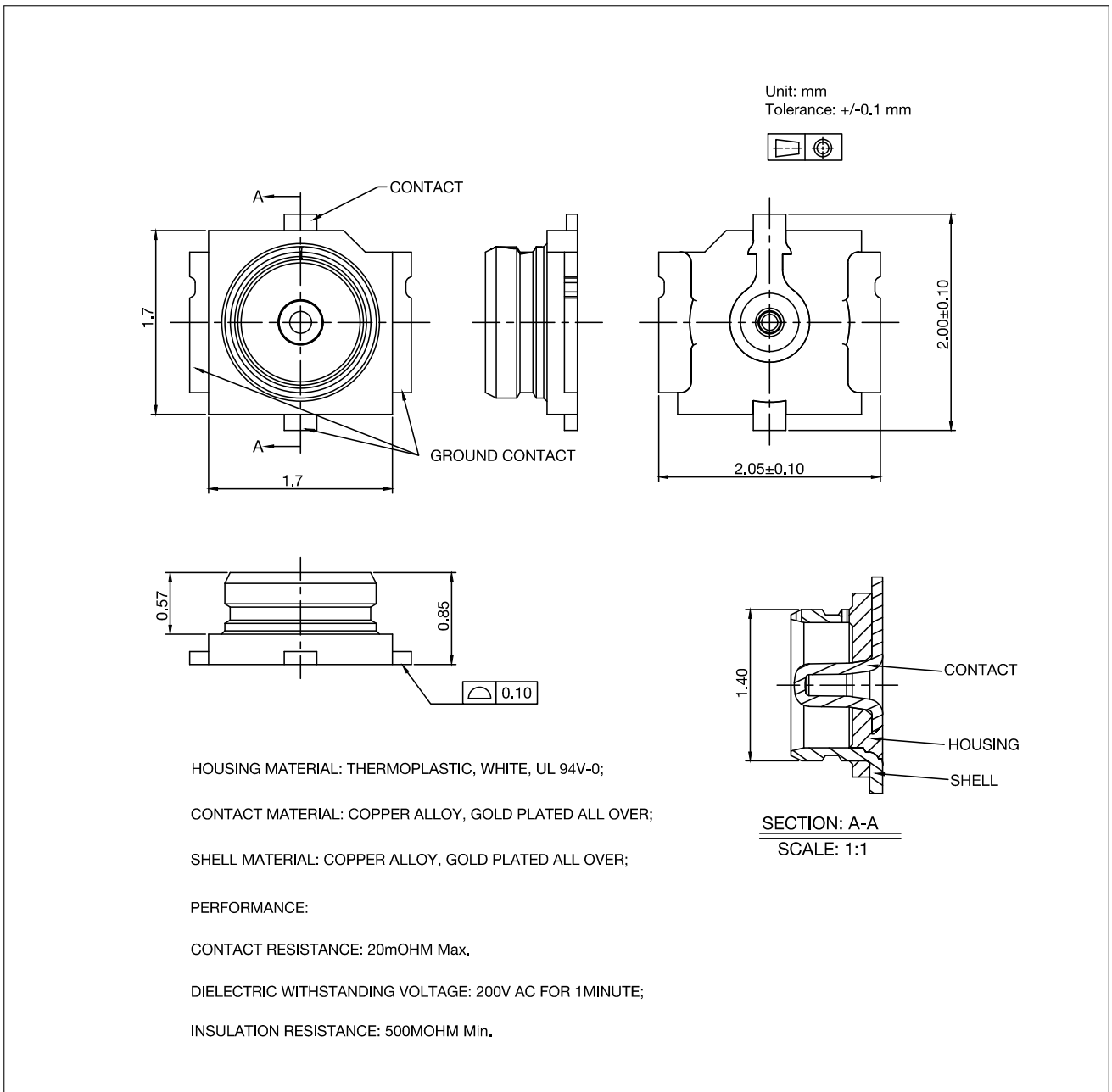

Figure 13: Dimensions of External Antenna Connector

8 Product Handling

8.1 Storage Conditions

The products sealed in moisture barrier bags (MBB) should be stored in a non-condensing atmospheric environment of $< 40\text{ }^{\circ}\text{C}$ and 90%RH. The module is rated at the moisture sensitivity level (MSL) of 3.

After unpacking, the module must be soldered within 168 hours with the factory conditions $25 \pm 5\text{ }^{\circ}\text{C}$ and 60 %RH. If the above conditions are not met, the module needs to be baked.

8.2 Electrostatic Discharge (ESD)

- Human body model (HBM): $\pm 2000\text{ V}$
- Charged-device model (CDM): $\pm 500\text{ V}$

8.3 Reflow Profile

Solder the module in a single reflow.

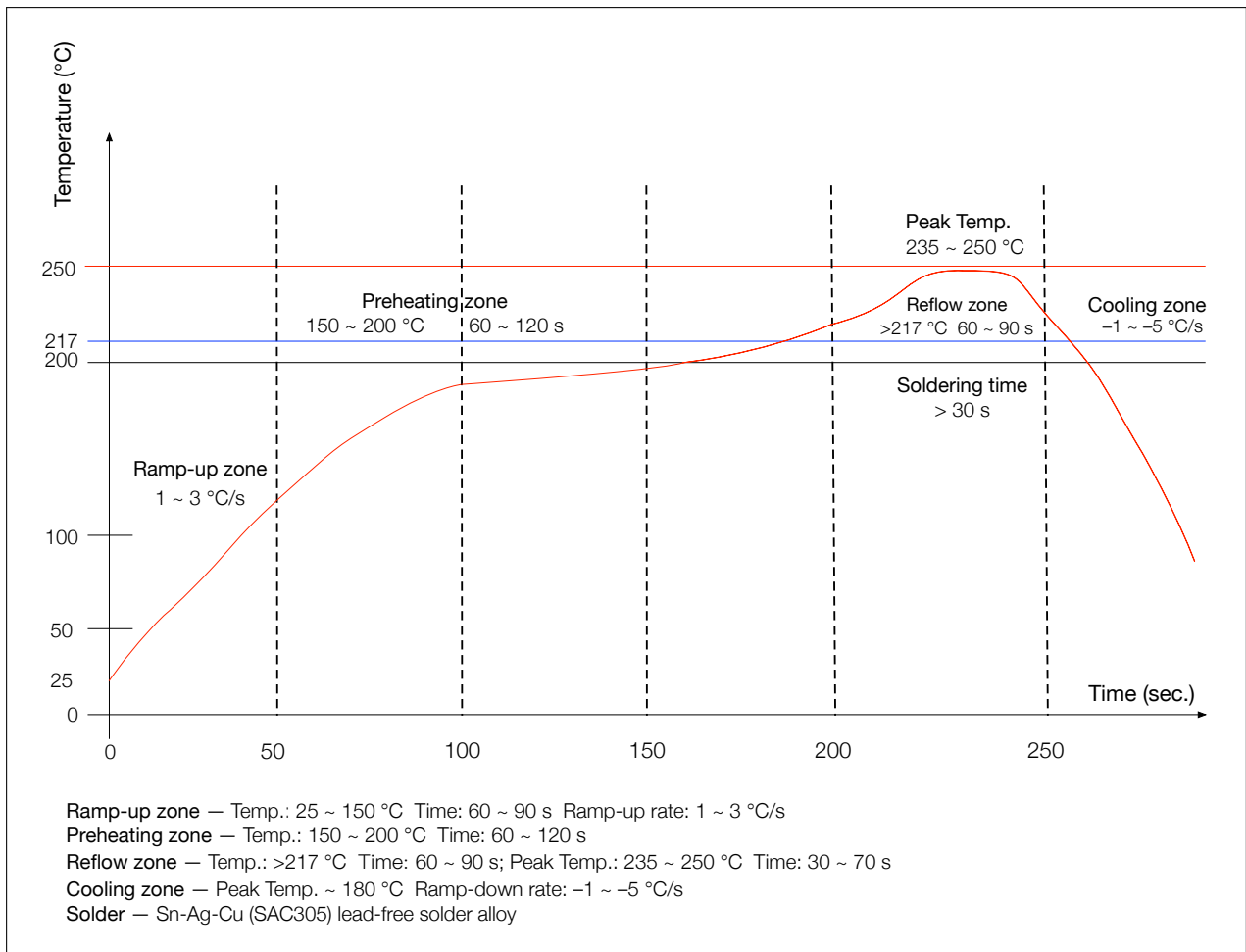

Figure 14: Reflow Profile

8.4 Ultrasonic Vibration

Avoid exposing Espressif modules to vibration from ultrasonic equipment, such as ultrasonic welders or ultrasonic cleaners. This vibration may induce resonance in the in-module crystal and lead to its malfunction or even failure. As a consequence, **the module may stop working or its performance may deteriorate.**

9 Related Documentation and Resources

Related Documentation

- [ESP32 Series Datasheet](#) – Specifications of the ESP32 hardware.
- [ESP32 Technical Reference Manual](#) – Detailed information on how to use the ESP32 memory and peripherals.
- [ESP32 Hardware Design Guidelines](#) – Guidelines on how to integrate the ESP32 into your hardware product.
- [ESP32 ECO and Workarounds for Bugs](#) – Correction of ESP32 design errors.
- *Certificates*
<https://espressif.com/en/support/documents/certificates>
- *ESP32 Product/Process Change Notifications (PCN)*
<https://espressif.com/en/support/documents/pcns>
- *ESP32 Advisories* – Information on security, bugs, compatibility, component reliability.
<https://espressif.com/en/support/documents/advisories>
- *Documentation Updates and Update Notification Subscription*
<https://espressif.com/en/support/download/documents>

Developer Zone

- [ESP-IDF Programming Guide for ESP32](#) – Extensive documentation for the ESP-IDF development framework.
- *ESP-IDF* and other development frameworks on GitHub.
<https://github.com/espressif>
- *ESP32 BBS Forum* – Engineer-to-Engineer (E2E) Community for Espressif products where you can post questions, share knowledge, explore ideas, and help solve problems with fellow engineers.
<https://esp32.com/>
- *The ESP Journal* – Best Practices, Articles, and Notes from Espressif folks.
<https://blog.espressif.com/>
- See the tabs *SDKs and Demos, Apps, Tools, AT Firmware*.
<https://espressif.com/en/support/download/sdks-demos>

Products

- *ESP32 Series SoCs* – Browse through all ESP32 SoCs.
<https://espressif.com/en/products/socs?id=ESP32>
- *ESP32 Series Modules* – Browse through all ESP32-based modules.
<https://espressif.com/en/products/modules?id=ESP32>
- *ESP32 Series DevKits* – Browse through all ESP32-based devkits.
<https://espressif.com/en/products/devkits?id=ESP32>
- *ESP Product Selector* – Find an Espressif hardware product suitable for your needs by comparing or applying filters.
<https://products.espressif.com/#/product-selector?language=en>

Contact Us

- See the tabs *Sales Questions, Technical Enquiries, Circuit Schematic & PCB Design Review, Get Samples* (Online stores), *Become Our Supplier, Comments & Suggestions*.
<https://espressif.com/en/contact-us/sales-questions>

Revision History

Date	Version	Release notes
2023-11-21	v1.3	Section 6 <i>Peripheral Schematics</i> : Updated the note about EPAD soldering under the figure Section 7.2 <i>Recommended PCB Land Pattern</i> : Added the modules' 2D PCB source files
2022-12-02	v1.2	Added Figure 5 and Table 4 in Section 3.3: <i>Strapping Pins</i> Added Section 8.4: <i>Ultrasonic Vibration</i>
2022-03-28	v1.1	Added a link to RF certificates in Section 1.1 Updated the description of TWAI in Section 1.1 Updated Table 6
2021-07-15	v1.0	Added ESP32-PICO-MINI-02U module. Updated the document formatting.
2021-03-16	v0.5	Preliminary release



www.espressif.com

Disclaimer and Copyright Notice

Information in this document, including URL references, is subject to change without notice.

ALL THIRD PARTY'S INFORMATION IN THIS DOCUMENT IS PROVIDED AS IS WITH NO WARRANTIES TO ITS AUTHENTICITY AND ACCURACY.

NO WARRANTY IS PROVIDED TO THIS DOCUMENT FOR ITS MERCHANTABILITY, NON-INFRINGEMENT, FITNESS FOR ANY PARTICULAR PURPOSE, NOR DOES ANY WARRANTY OTHERWISE ARISING OUT OF ANY PROPOSAL, SPECIFICATION OR SAMPLE.

All liability, including liability for infringement of any proprietary rights, relating to use of information in this document is disclaimed. No licenses express or implied, by estoppel or otherwise, to any intellectual property rights are granted herein.

The Wi-Fi Alliance Member logo is a trademark of the Wi-Fi Alliance. The Bluetooth logo is a registered trademark of Bluetooth SIG.

All trade names, trademarks and registered trademarks mentioned in this document are property of their respective owners, and are hereby acknowledged.

Copyright © 2023 Espressif Systems (Shanghai) Co., Ltd. All rights reserved.

Looking for pricing, stock, or lifecycle information?

Click below to explore more details on WIN SOURCE:

- ⊖ [View ESP32-PICO-MINI-02U-N8R2 on WIN SOURCE](#)
- ⊖ [Espressif Information](#)

Optimize Your Supply Chain with WIN SOURCE Solutions

- ✓ Global Sourcing Solution
- ✓ Obsolete Management
- ✓ Cost Control Management
- ✓ Shortage Management
- ✓ Alternative Solution
- ✓ Excess Inventory Management