



**THE DATASHEET OF
TX7516ALH**



TX7516 Five-Level, 16-Channel Transmitter with T/R Switch, and On-Chip Beamformer

1 Features

- Transmitter supports:
 - 16-channel 5-level pulser and active transmit/receive (T/R) switch
- 5-level pulser:
 - Maximum output voltage: ± 100 V
 - Minimum output voltage: ± 1 V
 - Maximum output current: 2 A
 - Support 4A output current mode.
 - True return to zero to discharge output to ground
 - Second harmonic of -45 dBc at 5 MHz
 - -3 -dB Bandwidth with $1\text{-k}\Omega \parallel 240\text{-pF}$ load
 - 20 MHz for a ± 100 -V supply
 - 25 MHz for a ± 70 -V supply
 - 35 MHz for a ± 100 -V supply in 4A mode
 - Integrated jitter: 100 fs measured from 100 Hz to 20 kHz
 - CW mode close-in phase noise: -154 dBc/Hz at 1 kHz offset for 5-MHz signal
 - Very low receive power: 1mW/ch
- Active transmit/receive (T/R) switch with:
 - Turnon resistance of $8\ \Omega$
 - Turnon and Turnoff time: 100 ns
 - Transient glitch: 10 mV_{PP}
- On-chip beam former with:
 - Channel based T/R switch on and off controls
 - Delay resolution: half beamformer clock period, minimum 2 ns
 - Maximum delay: 2^{14} beamformer clock period
 - Maximum beamformer clock speed: 320 MHz
 - Per channel pattern control with 2K distinct level.
 - Global and local repeat pattern, enabling long duration patterns for Shear Wave imaging
 - Supports 120 delay profiles
- High-speed (400 MHz maximum), 2-lane LVDS serial programming interface.
 - Low programming time: < 500 ns for delay profile update
 - 32-bit Checksum feature to detect wrong SPI writes
- Supports CMOS serial programming interface (50 MHz maximum)
- Internal temperature sensor and automatic thermal shutdown
- No specific power sequencing requirement
- Error flag register to detect faulty conditions
- Integrated passives for the floating supplies and bias voltages

- Small package: FC-BGA-144 (10 mm × 10 mm) with 0.8-mm pitch

2 Applications

- Ultrasound imaging system
- Piezoelectric driver
- In-probe ultrasound imaging

3 Description

TX7516 is a highly integrated, high-performance transmitter solution for ultrasound imaging system. The device has total 16 pulser circuits, 16 transmit/receive switches (referred as T/R or TR switches), and supports on-chip beamformer (TxBF). The device also integrates on-chip floating power supplies that reduce the number of required high voltage power supplies.

TX7516 has a pulser circuit that generates five-level high voltage pulses (up to ± 100 V) that is used to excite multiple channels of an ultrasound transducer. The device supports total 16 outputs. The maximum output current is 2 A.

Device can be used as a transmitter solution for many applications like ultrasound imaging, non-destructive testing, SONAR, LIDAR, marine navigation system, brain imaging systems and so on.

Device Information

PART NUMBER	PACKAGE ⁽¹⁾	BODY SIZE (NOM)
TX7516	FC-BGA (144)	10.0 mm × 10.0 mm

- (1) For all available packages, see the orderable addendum at the end of the data sheet.

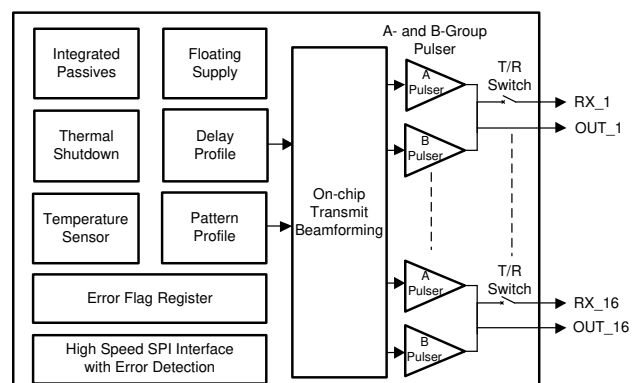

Simplified Block Diagram

Table of Contents

1 Features	1	6.2 Receiving Notification of Documentation Updates.....	4
2 Applications	1	6.3 Support Resources.....	4
3 Description	1	6.4 Trademarks.....	4
4 Revision History	2	6.5 Electrostatic Discharge Caution.....	4
5 Description (continued)	3	6.6 Glossary.....	4
6 Device and Documentation Support	4	7 Mechanical, Packaging, and Orderable Information	4
6.1 Document Support.....	4	7.1 Mechanical Data.....	5

4 Revision History

NOTE: Page numbers for previous revisions may differ from page numbers in the current version.

Changes from Revision * (June 2021) to Revision A (March 2022)	Page
• Changed device status from <i>Advanced Information</i> to <i>Production Data</i>	1

5 Description (continued)

TX7516 (referred as device in this data sheet) is highly integrated transmitter solution targeted for exciting ultrasound transducers. Device integrates 16 pulsers and 16 T/R switches, on-chip beamformer, and pattern generator.

Pulsar circuit generates five-level high voltage pulses (up to ± 100 V) with maximum output current of 2A. When pulser transmits the high voltage pulses, T/R switch turns OFF and protects the low voltage receiver circuit from damage. When the transducer is receiving echo signals, the T/R switch turns ON and connects the transducer to the receiver. The ON/OFF operation of the T/R switch is controlled by on-chip beamforming engine in the device. The T/R switch offers 8- Ω impedance in the ON state.

Ultrasound transmission relies on excitation of multiple transducer elements, with different delay values defining the direction of the transmission. Such an operation is referred to as transmit beamforming. TX7516 supports staggered pulsing of the different channels, allowing for transmit beamforming.

In the on-chip beamformer mode, delay profile for pulsing of different channels is stored within the device. The device supports a transmit beamformer delay resolution of one beamformer clock period and a maximum delay of 2^{14} beamformer clock periods. An internal pattern generator generates the output pulse patterns based on pattern profiles stored in a profile RAM. Each channel has its own RAM, which is 960 words long. The patterns have global and local repeats feature. This capability can be used to generate long patterns and can be used in Shear-Wave imaging.

These pattern profiles and delay profiles are written using a high speed (400 MHz) serial peripheral interface. The high-speed writes could be prone to errors. Hence, the device has a checksum feature to detect errors in SPI writes.

To protect the device from getting damaged because of improper configuration, an internal error flag register can detect faulty condition and configure the device in shutdown mode automatically.

The device integrates all the decoupling capacitors required for the floating supplies and internal bias voltages. This significantly reduces the required number of external capacitors. TX7516 is available in a 10-mm \times 10-mm 144-pin FC-BGA package (ALH package) and is specified for operation from 0°C to 70°C.

6 Device and Documentation Support

6.1 Document Support

Table 6-1. Terms Commonly Used in the Data Sheet

Abbreviation	Comment
PRT	Pulse Repetition Time. Represent TR_BF_SYNC period
PRF	Pulse Repetition Frequency. Represent TR_BF_SYNC frequency
Receive Mode	Duration in which T/R switch of all the channels are in ON state
High voltage supplies	AVDDP_HV_A, AVDDP_HV_B, AVDDM_HV_A, and AVDDM_HV_B are collectively referred as high voltage supplies
High voltage supplies	AVDDP_5, AVDDM_5, and AVDDP_1P8 supplies are collectively referred as low voltage supplies
A-side supplies	AVDDP_HV_A and AVDDM_HV_A is referred as A-side supplies
B-side supplies	AVDDP_HV_A and AVDDM_HV_A is referred as B-side supplies
SPI	Serial program interface

6.2 Receiving Notification of Documentation Updates

To receive notification of documentation updates, navigate to the device product folder on ti.com. In the upper right corner, click on *Alert me* to register and receive a weekly digest of any product information that has changed. For change details, review the revision history included in any revised document.

6.3 Support Resources

[TI E2E™ support forums](#) are an engineer's go-to source for fast, verified answers and design help — straight from the experts. Search existing answers or ask your own question to get the quick design help you need.

Linked content is provided "AS IS" by the respective contributors. They do not constitute TI specifications and do not necessarily reflect TI's views; see TI's [Terms of Use](#).

6.4 Trademarks

TI E2E™ is a trademark of Texas Instruments.

All trademarks are the property of their respective owners.

6.5 Electrostatic Discharge Caution



This integrated circuit can be damaged by ESD. Texas Instruments recommends that all integrated circuits be handled with appropriate precautions. Failure to observe proper handling and installation procedures can cause damage.

ESD damage can range from subtle performance degradation to complete device failure. Precision integrated circuits may be more susceptible to damage because very small parametric changes could cause the device not to meet its published specifications.

6.6 Glossary

[TI Glossary](#) This glossary lists and explains terms, acronyms, and definitions.

7 Mechanical, Packaging, and Orderable Information

The following pages include mechanical, packaging, and orderable information. This information is the most current data available for the designated devices. This data is subject to change without notice and revision of this document. For browser-based versions of this datasheet, refer to the left-hand navigation.

7.1 Mechanical Data

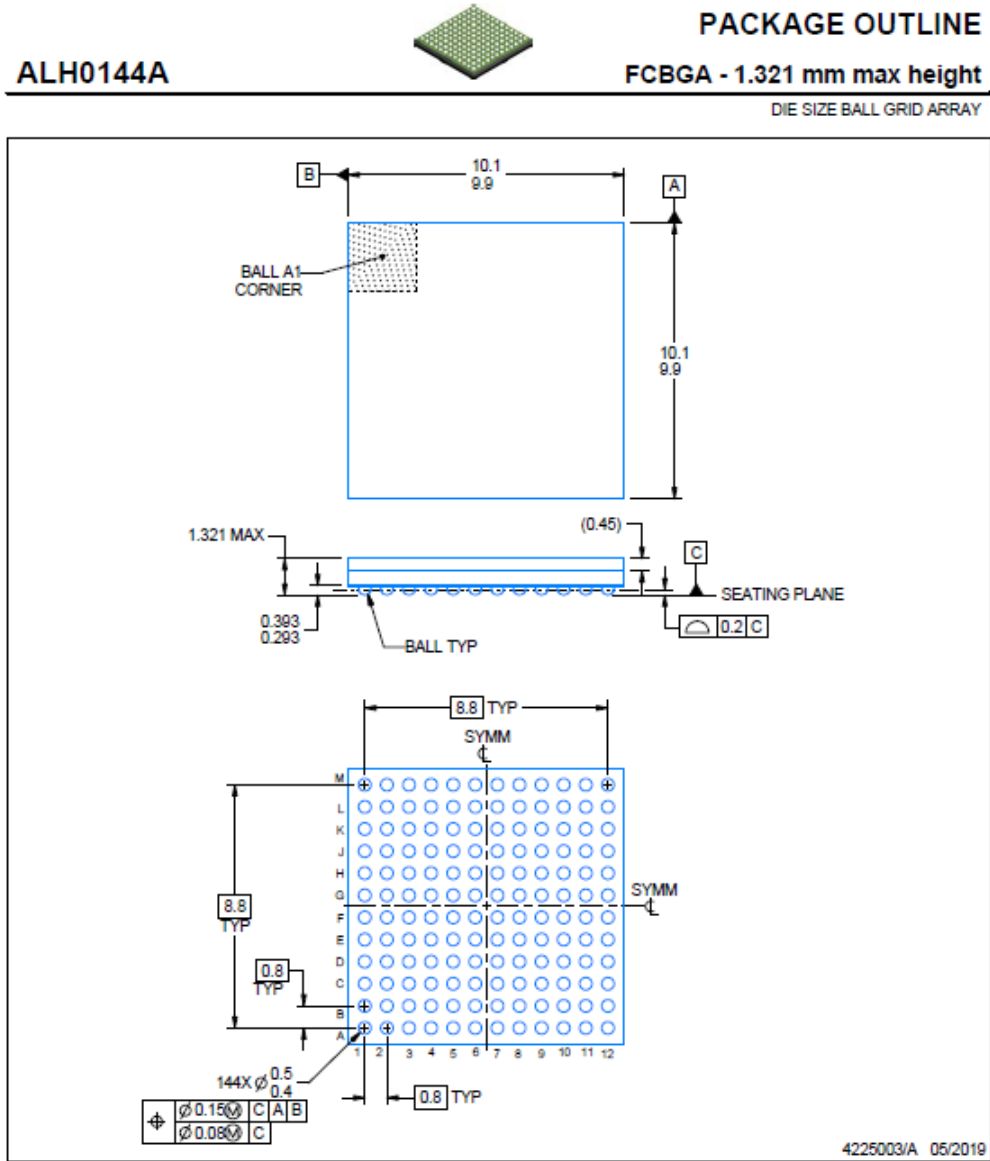

NOTES:

1. All linear dimensions are in millimeters. Any dimensions in parenthesis are for reference only. Dimensioning and tolerancing per ASME Y14.5M.
2. This drawing is subject to change without notice.

EXAMPLE BOARD LAYOUT

ALH0144A

FCBGA - 1.321 mm max height

DIE SIZE BALL GRID ARRAY

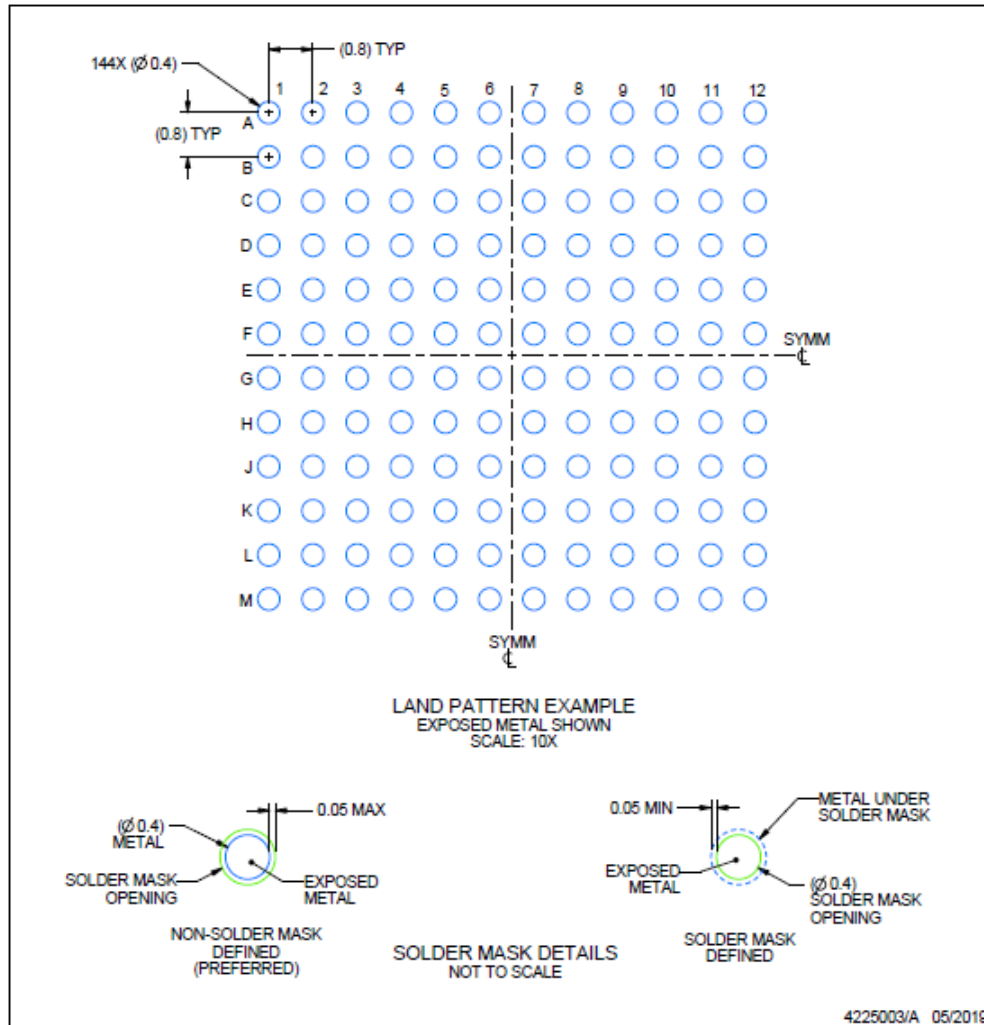

NOTES: (continued)

- 3. Final dimensions may vary due to manufacturing tolerance considerations and also routing constraints. See Texas Instruments Literature No. SPRU811 (www.ti.com/lit/spru811).

EXAMPLE STENCIL DESIGN

ALH0144A

FCBGA - 1.321 mm max height

DIE SIZE BALL GRID ARRAY

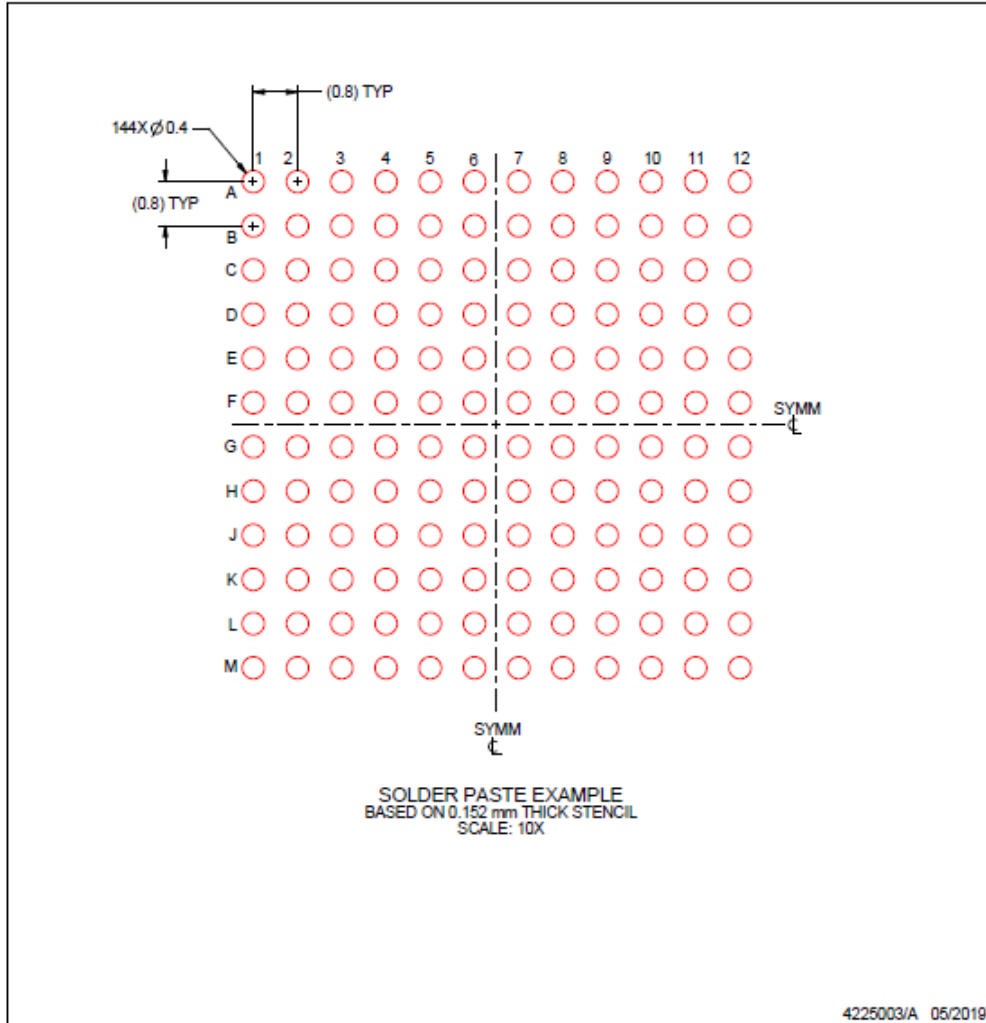

NOTES: (continued)

- 4. Laser cutting apertures with trapezoidal walls and rounded corners may offer better paste release.

PACKAGING INFORMATION

Orderable Device	Status (1)	Package Type	Package Drawing	Pins	Package Qty	Eco Plan (2)	Lead finish/ Ball material (6)	MSL Peak Temp (3)	Op Temp (°C)	Device Marking (4/5)	Samples
TX7516ALH	ACTIVE	FCCSP	ALH	144	240	RoHS & Green	SNAGCU	Level-3-260C-168 HR	0 to 70	TX7516	Samples

(1) The marketing status values are defined as follows:

ACTIVE: Product device recommended for new designs.

LIFEBUY: TI has announced that the device will be discontinued, and a lifetime-buy period is in effect.

NRND: Not recommended for new designs. Device is in production to support existing customers, but TI does not recommend using this part in a new design.

PREVIEW: Device has been announced but is not in production. Samples may or may not be available.

OBSELETE: TI has discontinued the production of the device.

(2) **RoHS:** TI defines "RoHS" to mean semiconductor products that are compliant with the current EU RoHS requirements for all 10 RoHS substances, including the requirement that RoHS substance do not exceed 0.1% by weight in homogeneous materials. Where designed to be soldered at high temperatures, "RoHS" products are suitable for use in specified lead-free processes. TI may reference these types of products as "Pb-Free".

RoHS Exempt: TI defines "RoHS Exempt" to mean products that contain lead but are compliant with EU RoHS pursuant to a specific EU RoHS exemption.

Green: TI defines "Green" to mean the content of Chlorine (Cl) and Bromine (Br) based flame retardants meet JS709B low halogen requirements of <=1000ppm threshold. Antimony trioxide based flame retardants must also meet the <=1000ppm threshold requirement.

(3) MSL, Peak Temp. - The Moisture Sensitivity Level rating according to the JEDEC industry standard classifications, and peak solder temperature.

(4) There may be additional marking, which relates to the logo, the lot trace code information, or the environmental category on the device.

(5) Multiple Device Markings will be inside parentheses. Only one Device Marking contained in parentheses and separated by a "~" will appear on a device. If a line is indented then it is a continuation of the previous line and the two combined represent the entire Device Marking for that device.

(6) Lead finish/Ball material - Orderable Devices may have multiple material finish options. Finish options are separated by a vertical ruled line. Lead finish/Ball material values may wrap to two lines if the finish value exceeds the maximum column width.

Important Information and Disclaimer:The information provided on this page represents TI's knowledge and belief as of the date that it is provided. TI bases its knowledge and belief on information provided by third parties, and makes no representation or warranty as to the accuracy of such information. Efforts are underway to better integrate information from third parties. TI has taken and continues to take reasonable steps to provide representative and accurate information but may not have conducted destructive testing or chemical analysis on incoming materials and chemicals. TI and TI suppliers consider certain information to be proprietary, and thus CAS numbers and other limited information may not be available for release.

In no event shall TI's liability arising out of such information exceed the total purchase price of the TI part(s) at issue in this document sold by TI to Customer on an annual basis.

IMPORTANT NOTICE AND DISCLAIMER

TI PROVIDES TECHNICAL AND RELIABILITY DATA (INCLUDING DATA SHEETS), DESIGN RESOURCES (INCLUDING REFERENCE DESIGNS), APPLICATION OR OTHER DESIGN ADVICE, WEB TOOLS, SAFETY INFORMATION, AND OTHER RESOURCES "AS IS" AND WITH ALL FAULTS, AND DISCLAIMS ALL WARRANTIES, EXPRESS AND IMPLIED, INCLUDING WITHOUT LIMITATION ANY IMPLIED WARRANTIES OF MERCHANTABILITY, FITNESS FOR A PARTICULAR PURPOSE OR NON-INFRINGEMENT OF THIRD PARTY INTELLECTUAL PROPERTY RIGHTS.

These resources are intended for skilled developers designing with TI products. You are solely responsible for (1) selecting the appropriate TI products for your application, (2) designing, validating and testing your application, and (3) ensuring your application meets applicable standards, and any other safety, security, regulatory or other requirements.

These resources are subject to change without notice. TI grants you permission to use these resources only for development of an application that uses the TI products described in the resource. Other reproduction and display of these resources is prohibited. No license is granted to any other TI intellectual property right or to any third party intellectual property right. TI disclaims responsibility for, and you will fully indemnify TI and its representatives against, any claims, damages, costs, losses, and liabilities arising out of your use of these resources.

TI's products are provided subject to [TI's Terms of Sale](#) or other applicable terms available either on ti.com or provided in conjunction with such TI products. TI's provision of these resources does not expand or otherwise alter TI's applicable warranties or warranty disclaimers for TI products.

TI objects to and rejects any additional or different terms you may have proposed.

Mailing Address: Texas Instruments, Post Office Box 655303, Dallas, Texas 75265
Copyright © 2022, Texas Instruments Incorporated

Looking for pricing, stock, or lifecycle information?

Click below to explore more details on WIN SOURCE:

 [View TX7516ALH on WIN SOURCE](#)

 [Texas Instruments](#) Information

Optimize Your Supply Chain with WIN SOURCE Solutions

-  Global Sourcing Solution
-  Obsolete Management
-  Cost Control Management
-  Shortage Management
-  Alternative Solution
-  Excess Inventory Management