



THE DATASHEET OF
ASP-209948-01



REVISION C

BY SIGNING THIS DOCUMENT YOU ARE ACCEPTING THE CONDITIONS SET WITHIN. YOUR REQUIREMENTS MUST BE LISTED WITHIN THIS DRAWING. WHERE NO DIRECTION FROM THE CUSTOMER IS IDENTIFIED SAMTEC'S PROCESS REQUIREMENTS WILL BE USED.

DATE: _____
 COMPANY: _____
 CUSTOMER SIGNATURE: _____
 PRINTED NAME: _____
 PHONE No: _____
 EXCEPTIONS: _____

- NOTES:
1. MINIMUM PUSHOUT FORCE: 1.2N
 2. PARTS TO BE PACKAGED IN TAPE & REEL.
 3. ATTACH LABEL -4X2 TO EACH REEL.
 4. ORDERS WILL BE PACKAGED ACCORDING TO THE SAMTEC PACKAGING EFFICIENCY STANDARDS (SPES) FOUND ON WWW.SAMTEC.COM.

DESIGNED AND DIMENSIONED IN MILLIMETERS[INCHES]
ALL DIMENSIONS REFERENCE EXCEPT AS SHOWN

DO NOT SCALE FROM THIS PRINT

SOME CENTER FEATURES NOT SHOWN FOR CLARITY

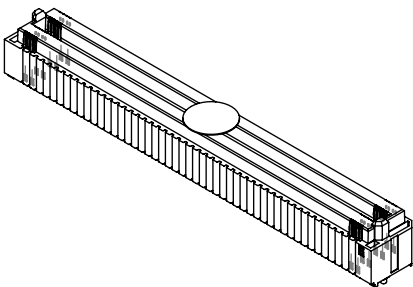
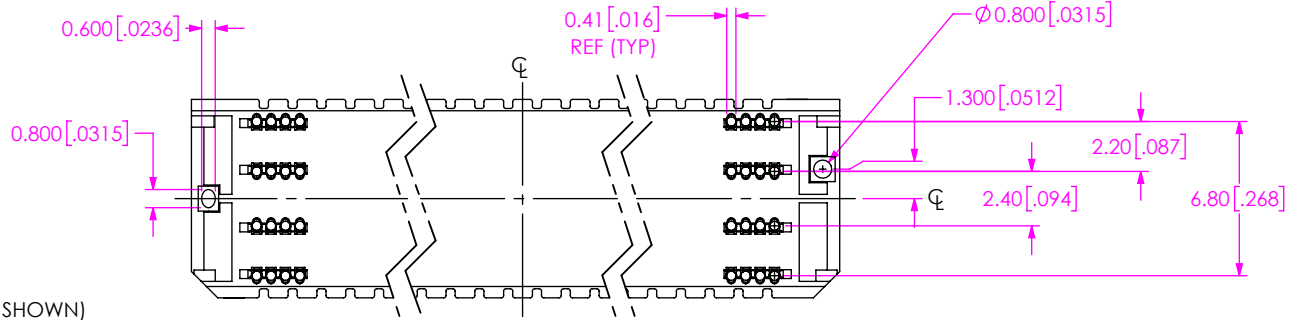
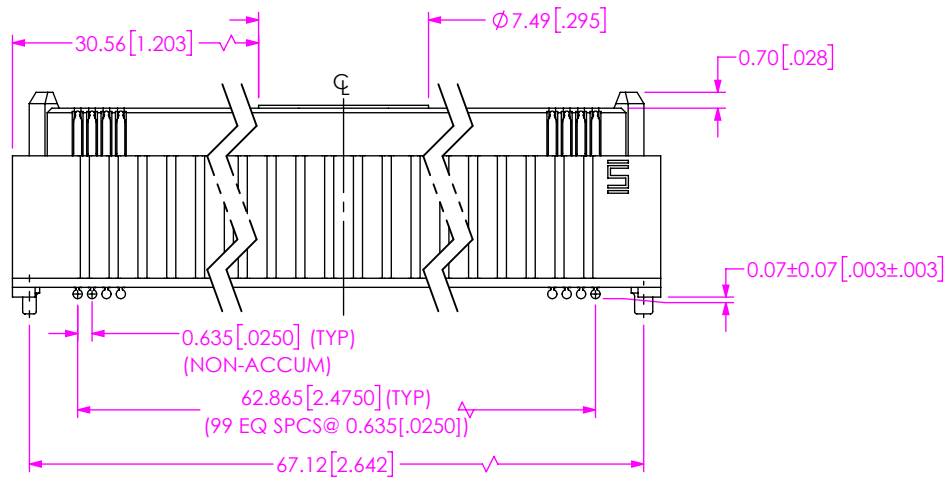
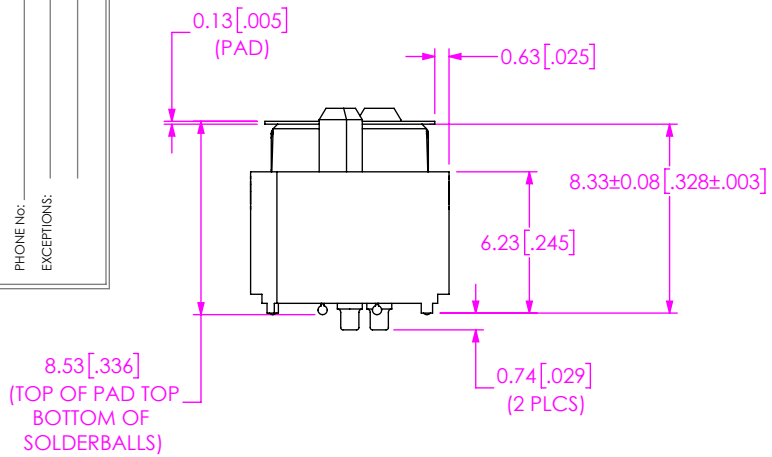
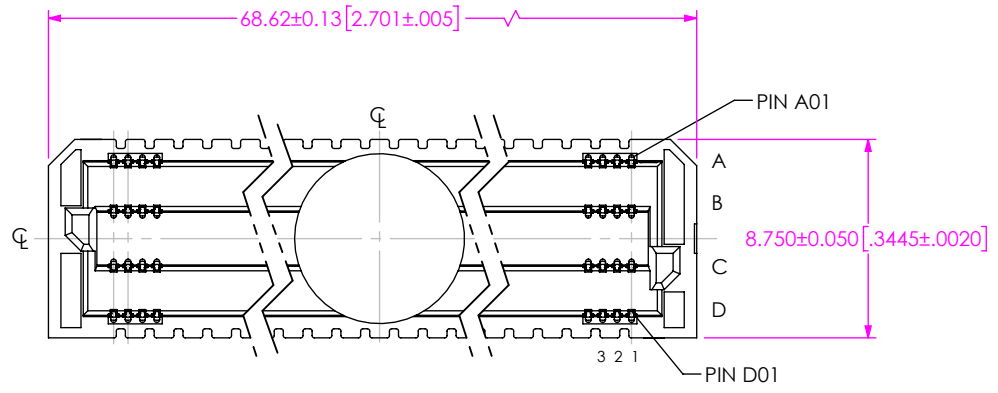



FIG 1
 (ASP-209948-01 SHOWN)

PROPRIETARY NOTE
 THIS DOCUMENT CONTAINS CONFIDENTIAL AND PROPRIETARY INFORMATION AND ALL DESIGN, MANUFACTURING, REPRODUCTION, USE, PATENT RIGHTS AND SALES RIGHTS ARE EXPRESSLY RESERVED BY SAMTEC, INC. THIS DOCUMENT SHALL NOT BE DISCLOSED, IN WHOLE OR PART, TO ANY UNAUTHORIZED PERSON OR ENTITY NOR REPRODUCED, TRANSFERRED OR INCORPORATED IN ANY OTHER PROJECT IN ANY MANNER WITHOUT THE EXPRESS WRITTEN CONSENT OF SAMTEC, INC.

DO NOT SCALE DRAWING SHEET SCALE: 3:1
 MATERIAL:
INSULATOR: LCP, COLOR: NATURAL
 TERMINAL: COPPER ALLOY
 PLATING:
 CONTACT AREA: .00010" GOLD OVER .000050" NICKEL
 REMAINDER: .000200" REF TIN OVER .000050" NICKEL



520 PARK EAST BLVD, NEW ALBANY, IN 47150
 PHONE: 812-944-6733 FAX: 812-948-5047
 e-Mail info@SAMTEC.com code 55322

DESCRIPTION:
CUSTOM COM HPC MALE ASSEMBLY

DWG. NO. **ASP-209948-01**

BY: J. BROWNING 01/16/2019 SHEET 1 OF 8

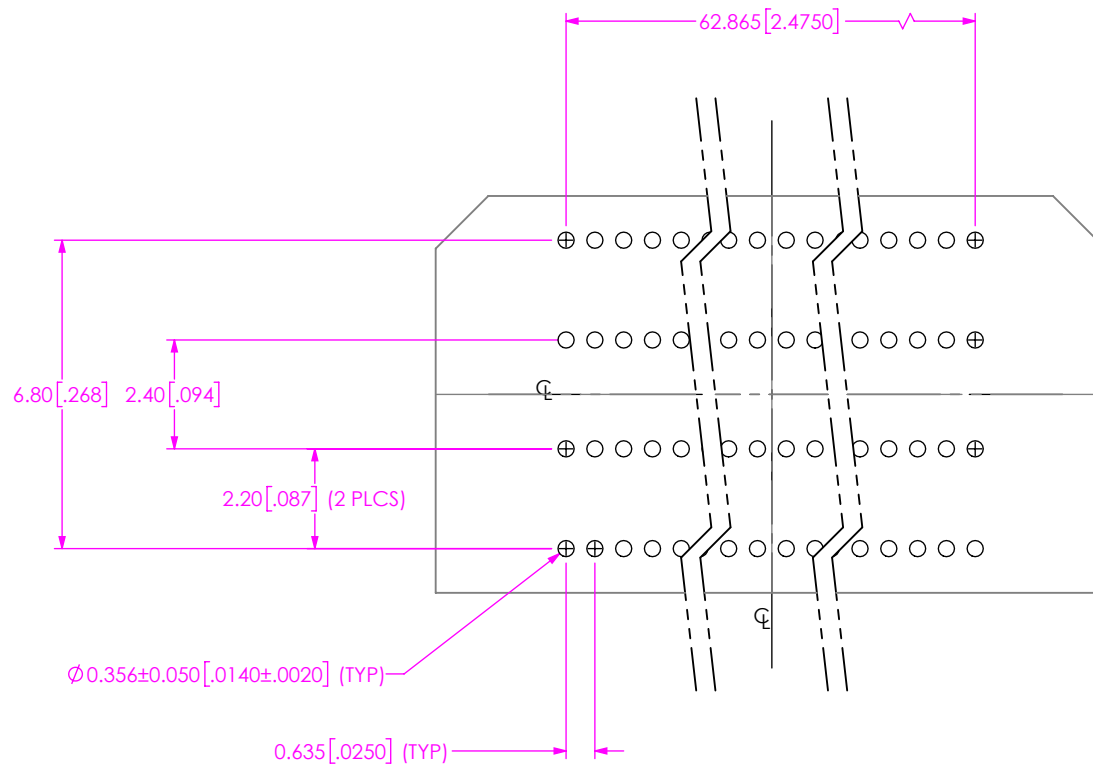

RECOMMENDED STENCIL LAYOUT
 ALL DIMENSIONS SYMMETRIC ABOUT CENTERLINE
 (STENCIL TO BE 0.125[.0050] THICK)

PROPRIETARY NOTE

THIS DOCUMENT CONTAINS CONFIDENTIAL AND PROPRIETARY INFORMATION AND ALL DESIGN, MANUFACTURING, REPRODUCTION, USE, PATENT RIGHTS AND SALES RIGHTS ARE EXPRESSLY RESERVED BY SAMTEC, INC. THIS DOCUMENT SHALL NOT BE DISCLOSED, IN WHOLE OR PART, TO ANY UNAUTHORIZED PERSON OR ENTITY NOR REPRODUCED, TRANSFERRED OR INCORPORATED IN ANY OTHER PROJECT IN ANY MANNER WITHOUT THE EXPRESS WRITTEN CONSENT OF SAMTEC, INC.



520 PARK EAST BLVD, NEW ALBANY, IN 47150
 PHONE: 812-944-6733 FAX: 812-948-5047
 e-Mail info@SAMTEC.com code 55322

SHEET SCALE: 1:1

DESCRIPTION:
 CUSTOM COM HPC MALE ASSEMBLY

DWG. NO.
 ASP-209948-01

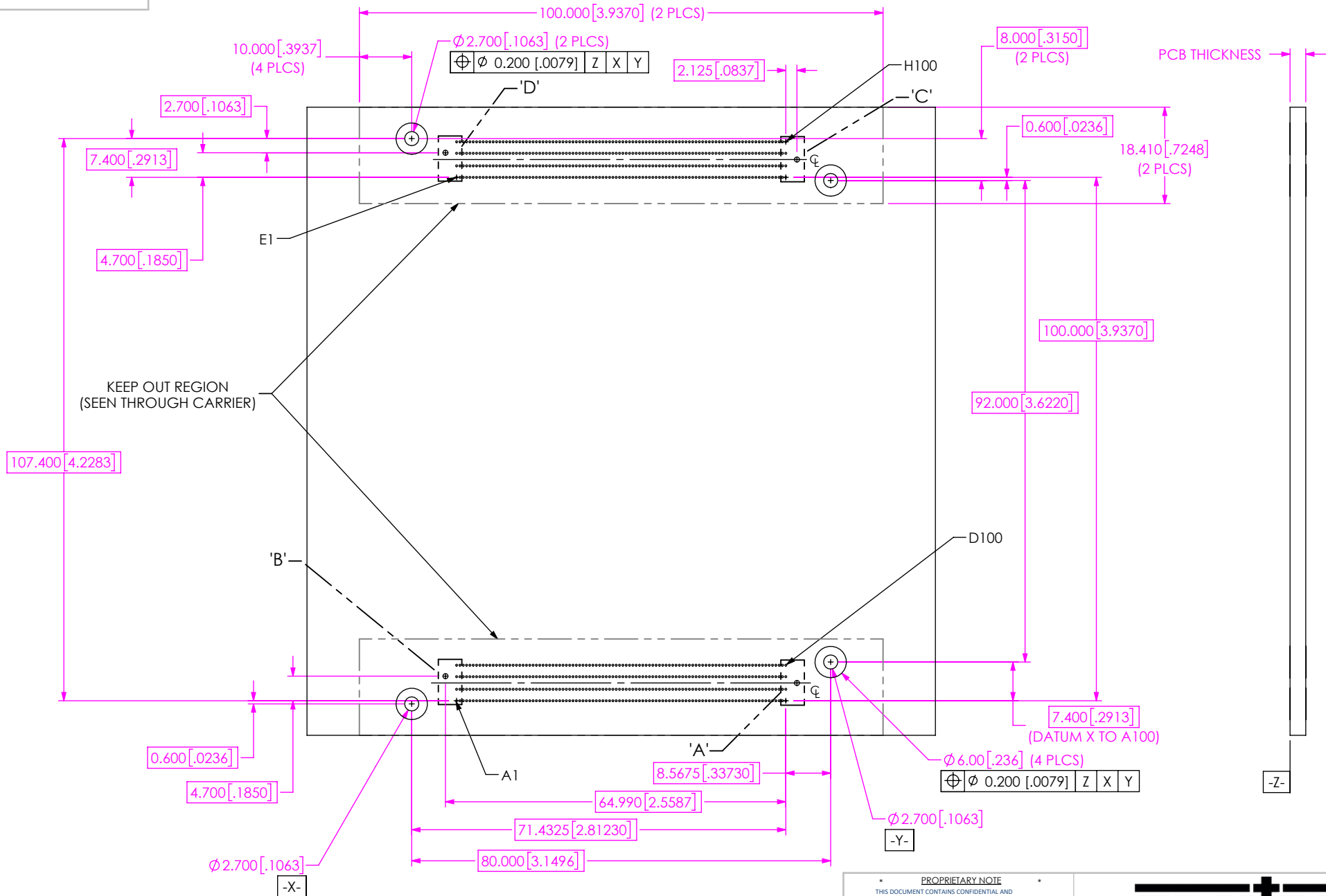
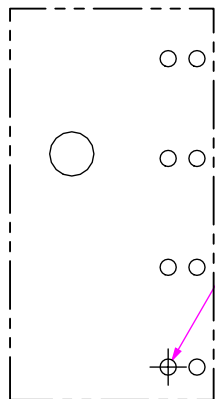

FIG 2
 (RECOMMENDED ASP-209948-01)
 (LAYOUT FOR COM-HPC® MODULE SIZE A & B)

<p>PROPRIETARY NOTE</p> <p>THIS DOCUMENT CONTAINS CONFIDENTIAL AND PROPRIETARY INFORMATION AND ALL DESIGN, MANUFACTURING, REPRODUCTION, USE, PATENT RIGHTS AND SALES RIGHTS ARE EXPRESSLY RESERVED BY SAMTEC, INC. THIS DOCUMENT SHALL NOT BE DISCLOSED, IN WHOLE OR PART, TO ANY UNAUTHORIZED PERSON OR ENTITY NOR REPRODUCED, TRANSFERRED OR INCORPORATED IN ANY OTHER PROJECT IN ANY MANNER WITHOUT THE EXPRESS WRITTEN CONSENT OF SAMTEC, INC.</p>	<p>samtec</p> <p>520 PARK EAST BLVD., NEW ALBANY, IN 47150 PHONE: 812-944-6733 FAX: 812-948-5047 e-Mail info@SAMTEC.com code 55322</p>	
	<p>SHEET SCALE: 1:1</p>	<p>DESCRIPTION: CUSTOM COM HPC MALE ASSEMBLY</p>
<p>DWG. NO.</p> <p>ASP-209948-01</p>		<p>BY: J. BROWNING 01/16/2019 SHEET 3 OF 8</p>



$\varnothing 0.356 \pm 0.030 [0.140 \pm 0.012]$

$\varnothing 0.100 [0.0039]$	Z	U	V
$\varnothing 0.200 [0.0079]$	Z	S	
-T-			

DETAIL 'D'
SCALE 6 : 1

$\varnothing 0.356 \pm 0.030 [0.140 \pm 0.012]$
(398 PLCS)

$\varnothing 0.100 [0.0039]$	Z	U	V
$\varnothing 0.100 [0.0039]$	Z	S	T

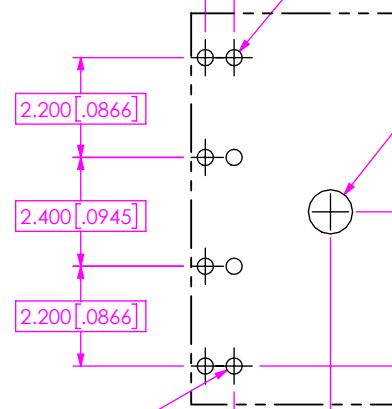

$\varnothing 0.975 \pm 0.030 [0.384 \pm 0.012]$
(2 PLCS)

$\varnothing 0.200 [0.0079]$	Z	U	V
$\varnothing 0.200 [0.0079]$	Z	S	T

$\varnothing 0.356 \pm 0.030 [0.140 \pm 0.012]$

$\varnothing 0.100 [0.0039]$	Z	U	V
-S-			

DETAIL 'C'
SCALE 6 : 1

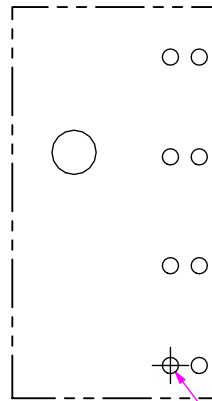

$\varnothing 0.356 \pm 0.030 [0.140 \pm 0.012]$

$\varnothing 0.200 [0.0079]$	Z	X	Y
$\varnothing 0.100 [0.0039]$	Z	U	
-V-			

DETAIL 'B'
SCALE 6 : 1

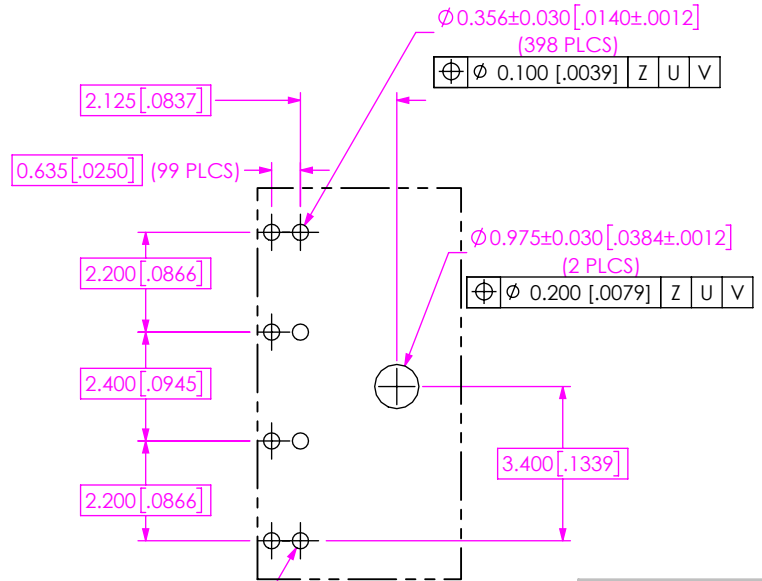

$\varnothing 0.356 \pm 0.030 [0.140 \pm 0.012]$
(398 PLCS)

$\varnothing 0.100 [0.0039]$	Z	U	V
------------------------------	---	---	---

$\varnothing 0.975 \pm 0.030 [0.384 \pm 0.012]$
(2 PLCS)

$\varnothing 0.200 [0.0079]$	Z	U	V
------------------------------	---	---	---

$\varnothing 0.356 \pm 0.030 [0.140 \pm 0.012]$

$\varnothing 0.200 [0.0079]$	Z	X	Y
-U-			

DETAIL 'A'
SCALE 6 : 1

PROPRIETARY NOTE
 THIS DOCUMENT CONTAINS CONFIDENTIAL AND PROPRIETARY INFORMATION AND ALL DESIGN, MANUFACTURING, REPRODUCTION, USE, PATENT RIGHTS AND SALES RIGHTS ARE EXPRESSLY RESERVED BY SAMTEC, INC. THIS DOCUMENT SHALL NOT BE DISCLOSED, IN WHOLE OR PART, TO ANY UNAUTHORIZED PERSON OR ENTITY NOR REPRODUCED, TRANSFERRED OR INCORPORATED IN ANY OTHER PROJECT IN ANY MANNER WITHOUT THE EXPRESS WRITTEN CONSENT OF SAMTEC, INC.

SHEET SCALE: 1:1

F:\DWG\MISC\MKTG\ASP-209948-01-MKT.SLDDRW

520 PARK EAST BLVD, NEW ALBANY, IN 47150
 PHONE: 812-944-6733 FAX: 812-948-5047
 e-Mail info@SAMTEC.com code 55322

DESCRIPTION:
 CUSTOM COM HPC MALE ASSEMBLY

DWG. NO.
ASP-209948-01

BY: J. BROWNING 01/16/2019 SHEET 4 OF 8

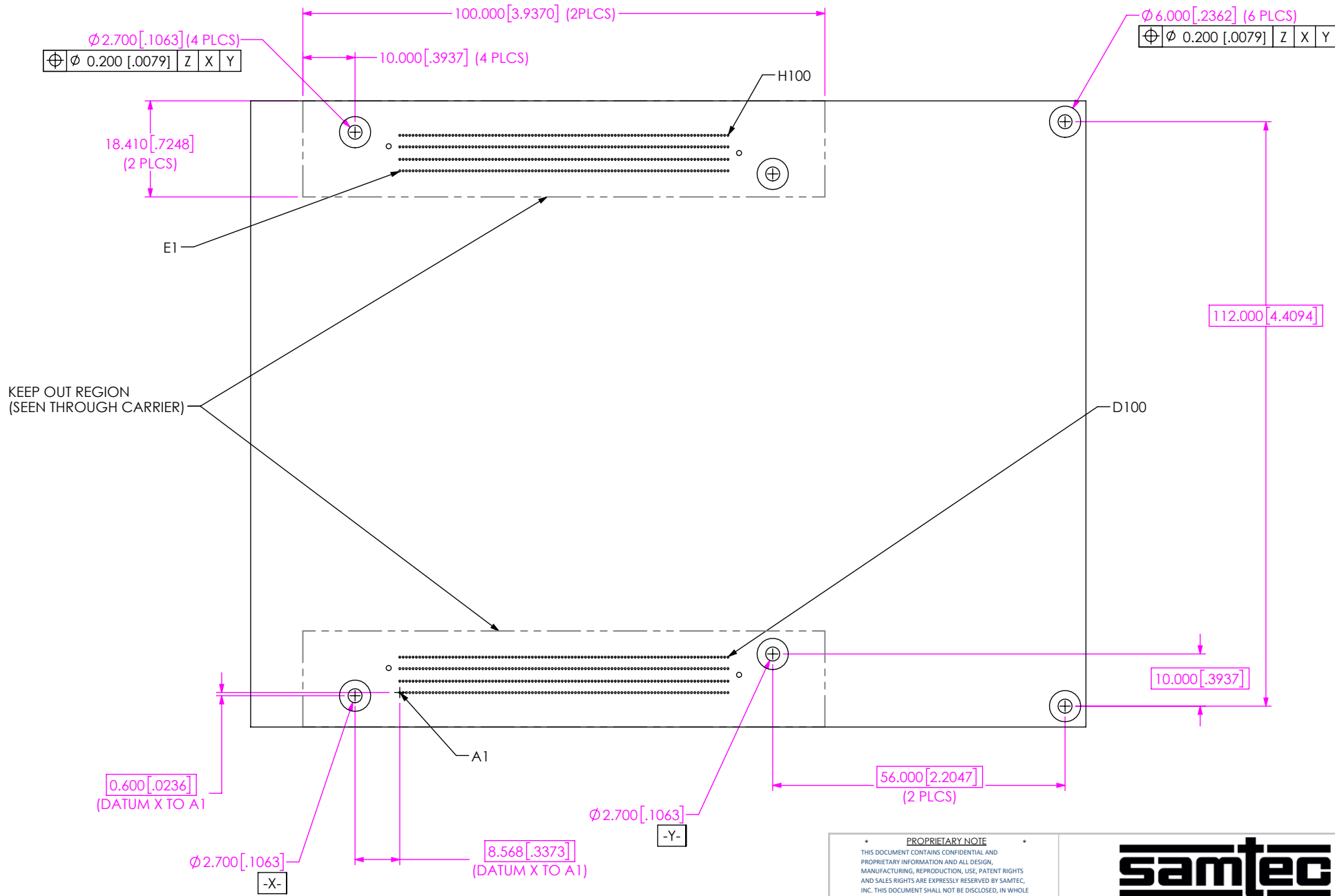

FIG 3
 (RECOMMENDED ASP-209948-01)
 (SAME AS FIG 2, EXCEPT AS SHOWN)
 (LAYOUT FOR COM-HPC® MODULE SIZE C)

<p>PROPRIETARY NOTE</p> <p>THIS DOCUMENT CONTAINS CONFIDENTIAL AND PROPRIETARY INFORMATION AND ALL DESIGN, MANUFACTURING, REPRODUCTION, USE, PATENT RIGHTS AND SALES RIGHTS ARE EXPRESSLY RESERVED BY SAMTEC, INC. THIS DOCUMENT SHALL NOT BE DISCLOSED, IN WHOLE OR PART, TO ANY UNAUTHORIZED PERSON OR ENTITY NOR REPRODUCED, TRANSFERRED OR INCORPORATED IN ANY OTHER PROJECT IN ANY MANNER WITHOUT THE EXPRESS WRITTEN CONSENT OF SAMTEC, INC.</p>	<p>samtec</p> <p>520 PARK EAST BLVD, NEW ALBANY, IN 47150 PHONE: 812-944-6733 FAX: 812-948-5047 e-Mail info@SAMTEC.com code 55322</p>
	<p>DESCRIPTION: CUSTOM COM HPC MALE ASSEMBLY</p>
<p>SHEET SCALE: 1:1</p>	<p>DWG. NO. ASP-209948-01</p>
<p>F:\DWG\MISC\MKTG\ASP-209948-01-MKT.SLDDRW</p>	<p>BY: J. BROWNING 01/16/2019 SHEET 5 OF 8</p>

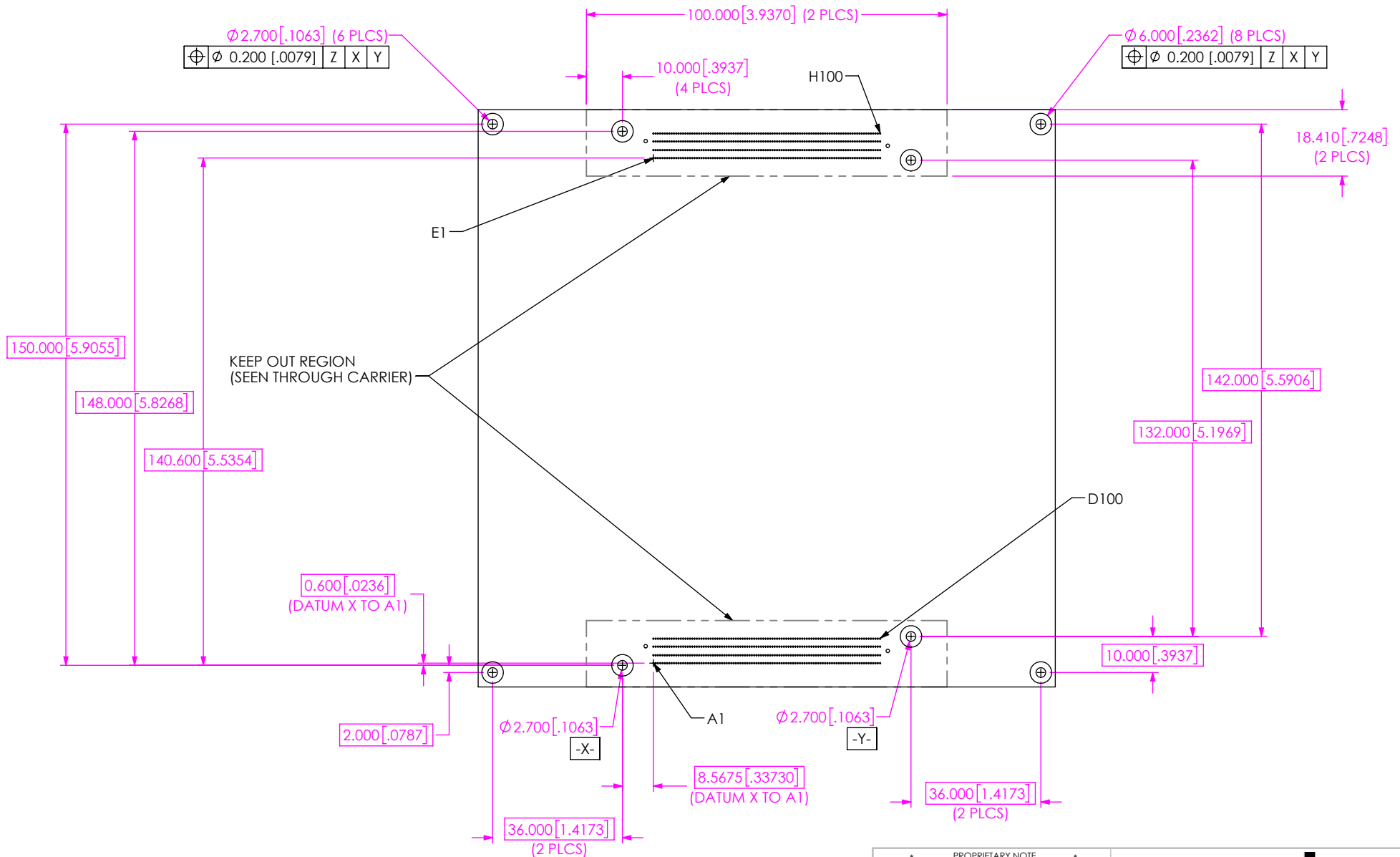

FIG 4
 (RECOMMENDED ASP-209948-01)
 (SAME AS FIG 2, EXCEPT AS SHOWN)
 (LAYOUT FOR COM-HPC® MODULE SIZE D)

<p>PROPRIETARY NOTE</p> <p>THIS DOCUMENT CONTAINS CONFIDENTIAL AND PROPRIETARY INFORMATION AND ALL DESIGN, MANUFACTURING, REPRODUCTION, USE, PATENT RIGHTS AND SALES RIGHTS ARE EXPRESSLY RESERVED BY SAMTEC, INC. THIS DOCUMENT SHALL NOT BE DISCLOSED, IN WHOLE OR PART, TO ANY UNAUTHORIZED PERSON OR ENTITY NOR REPRODUCED, TRANSFERRED OR INCORPORATED IN ANY OTHER PROJECT IN ANY MANNER WITHOUT THE EXPRESS WRITTEN CONSENT OF SAMTEC, INC.</p>	<p>samtec</p> <p>520 PARK EAST BLVD, NEW ALBANY, IN 47150 PHONE: 812-944-6733 FAX: 812-948-5047 e-Mail info@SAMTEC.com code 55322</p>
	<p>DESCRIPTION: CUSTOM COM HPC MALE ASSEMBLY</p>
<p>SHEET SCALE: 1:1</p>	<p>DWG. NO. ASP-209948-01</p>
<p>F:\DWG\MISC\MKTG\ASP-209948-01-MKT.SLDDRW</p>	<p>BY: J. BROWNING 01/16/2019 SHEET 6 OF 8</p>

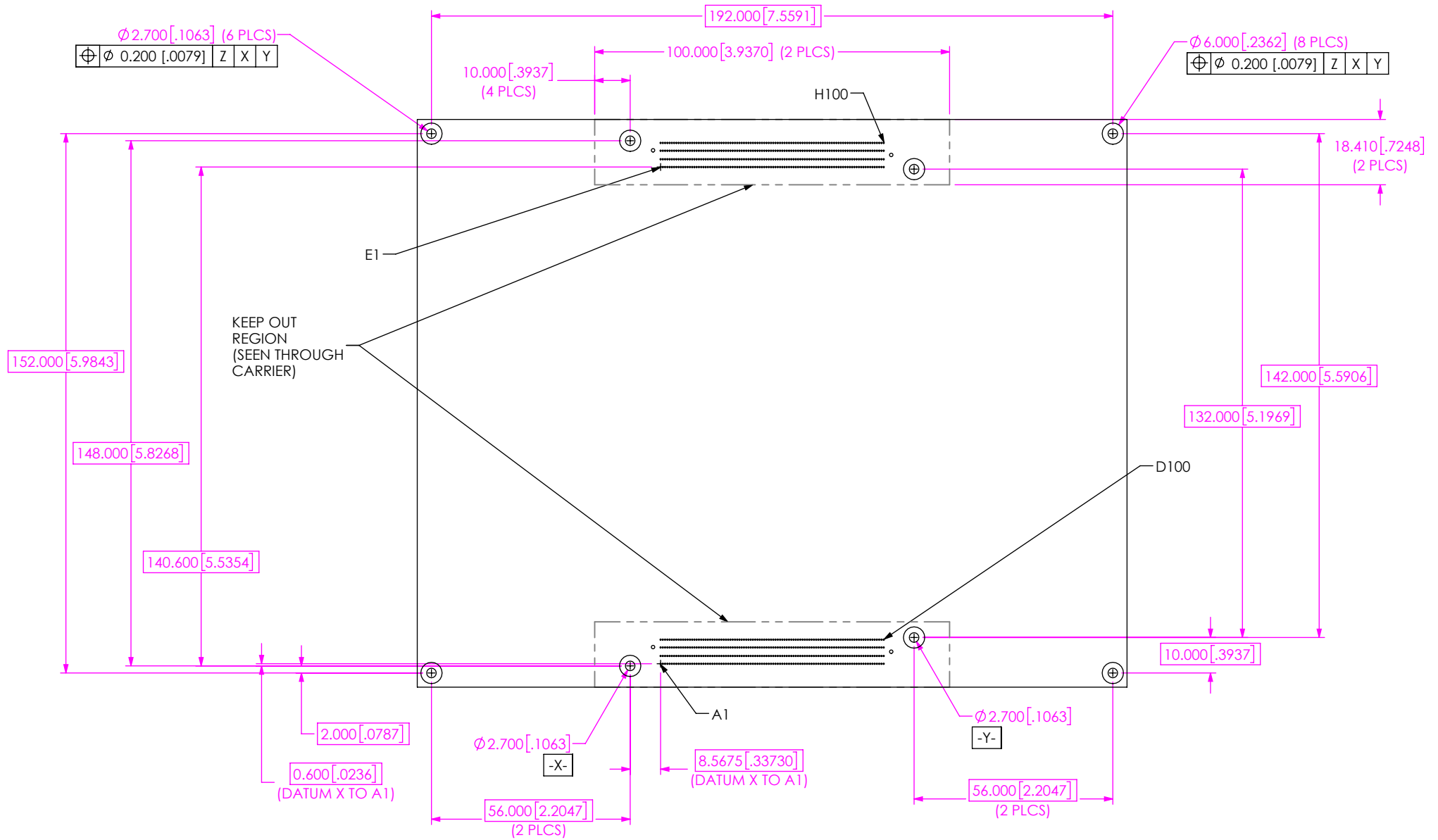

FIG 5
 (RECOMMENDED ASP-209948-01)
 (SAME AS FIG 2, EXCEPT AS SHOWN)
 (LAYOUT FOR COM-HPC® MODULE SIZE E)

<p>PROPRIETARY NOTE</p> <p>THIS DOCUMENT CONTAINS CONFIDENTIAL AND PROPRIETARY INFORMATION AND ALL DESIGN, MANUFACTURING, REPRODUCTION, USE, PATENT RIGHTS AND SALES RIGHTS ARE EXPRESSLY RESERVED BY SAMTEC, INC. THIS DOCUMENT SHALL NOT BE DISCLOSED, IN WHOLE OR PART, TO ANY UNAUTHORIZED PERSON OR ENTITY NOR REPRODUCED, TRANSFERRED OR INCORPORATED IN ANY OTHER PROJECT IN ANY MANNER WITHOUT THE EXPRESS WRITTEN CONSENT OF SAMTEC, INC.</p>	<p>DESCRIPTION: CUSTOM COM HPC MALE ASSEMBLY</p>
	<p>DWG. NO. ASP-209948-01</p>
<p>SHEET SCALE: 1:1</p>	<p>BY: J. BROWNING 01/16/2019 SHEET 7 OF 8</p>

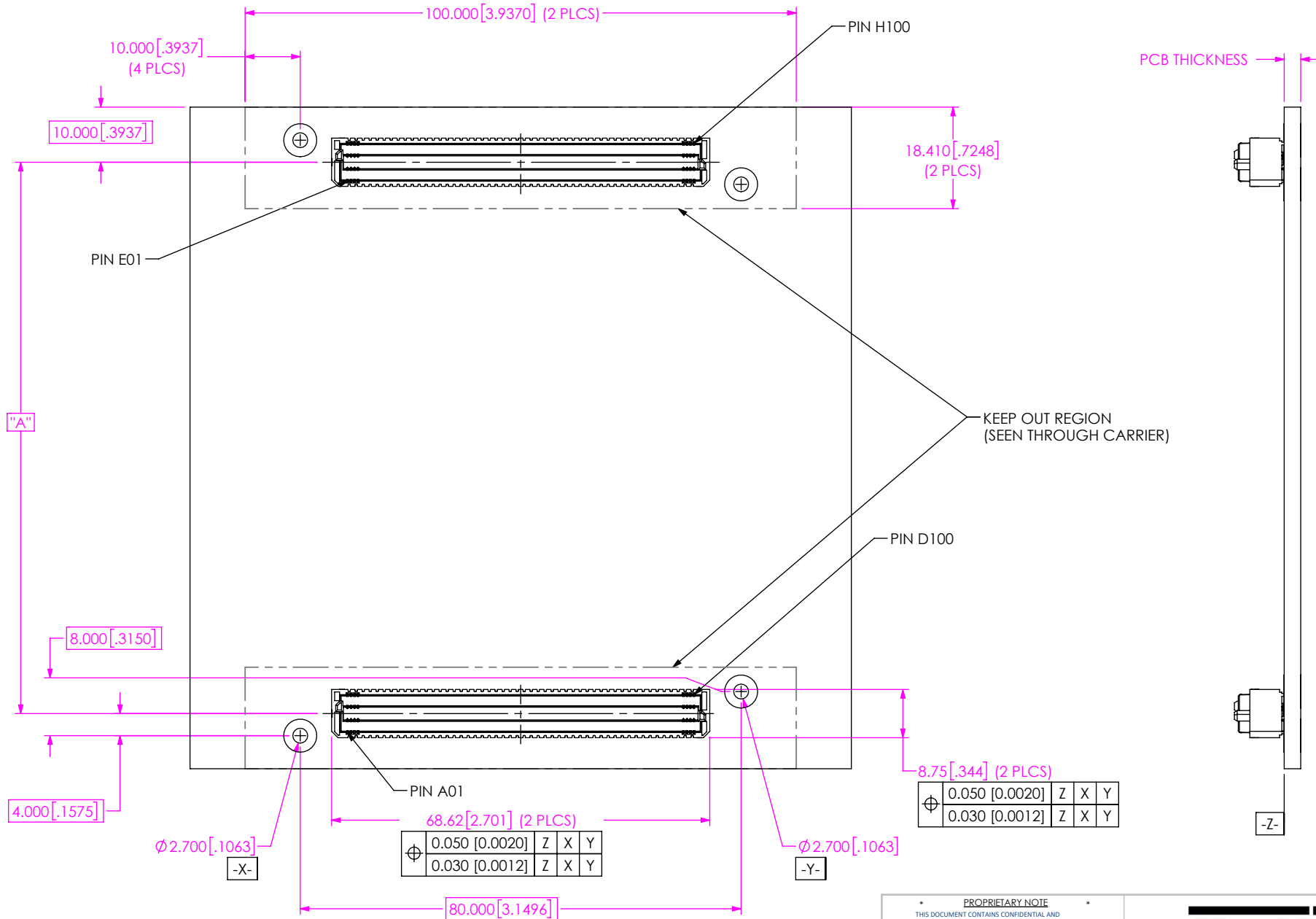

FIG 6
 COM-HPC® ASSEMBLY APPLICATION
 (RECOMMENDED ASP-209948-01 LAYOUT FOR COM-HPC®)

$\phi 2.700 [0.1063]$

\ominus	0.050 [0.0020]	Z	X	Y
-X-	0.030 [0.0012]	Z	X	Y

$\phi 2.700 [0.1063]$

\ominus	0.050 [0.0020]	Z	X	Y
-Y-	0.030 [0.0012]	Z	X	Y

$\phi 8.75 [.344] (2 PLCS)$

\ominus	0.050 [0.0020]	Z	X	Y
	0.030 [0.0012]	Z	X	Y

PROPRIETARY NOTE
 THIS DOCUMENT CONTAINS CONFIDENTIAL AND PROPRIETARY INFORMATION AND ALL DESIGN, MANUFACTURING, REPRODUCTION, USE, PATENT RIGHTS AND SALES RIGHTS ARE EXPRESSLY RESERVED BY SAMTEC, INC. THIS DOCUMENT SHALL NOT BE DISCLOSED, IN WHOLE OR PART, TO ANY UNAUTHORIZED PERSON OR ENTITY NOR REPRODUCED, TRANSFERRED OR INCORPORATED IN ANY OTHER PROJECT IN ANY MANNER WITHOUT THE EXPRESS WRITTEN CONSENT OF SAMTEC, INC.

samtec
 520 PARK EAST BLVD, NEW ALBANY, IN 47150
 PHONE: 812-944-6733 FAX: 812-948-5047
 e-Mail info@SAMTEC.com code 55322

SHEET SCALE: 1:1
 F:\DWG\MISC\MKTG\ASP-209948-01-MKT.SLDDRW

DESCRIPTION:
 CUSTOM COM HPC MALE ASSEMBLY
 DWG. NO.
ASP-209948-01
 BY: J. BROWNING 01/16/2019 SHEET 8 OF 8

Looking for pricing, stock, or lifecycle information?

Click below to explore more details on WIN SOURCE:

 [View ASP-209948-01](#) on WIN SOURCE

 [Samtec Inc.](#) Information

Optimize Your Supply Chain with WIN SOURCE Solutions

-  Global Sourcing Solution
-  Obsolete Management
-  Cost Control Management
-  Shortage Management
-  Alternative Solution
-  Excess Inventory Management