



**THE DATASHEET OF  
CCD-WOOE222Z632L02**



# CCD-W Series

Ceramic Disc Capacitors (Class 2 high voltage low D.F. ceramic dielectric capacitors)

**TRIGON**  
COMPONENTS



## FEATURES

- High Voltage, Low D.F, High Stable, High Reliability
- Coated with flame-retardant epoxy resin
- Relative Standards:
  - IEC 384-9: 1988 (Fixed capacitors of ceramic dielectric, class 2)
  - GB/T 5698-1966 (Fixed capacitors of ceramic dielectric, class 2)
  - GB 9322-88 (Fixed class 2 high voltage ceramic dielectric capacitors)
- RoHS Compliant

## APPLICATION

- Electronic Control Gear (Ballast)
- Television
- Power Supply , High Voltage Circuit etc

## ORDERING CODE

**CCD - W 10 E 222 K 102 L 5 1**

(1) (2) (3) (4) (5) (6) (7) (8) (9) (10)

- (1) Ceramic Disc Capacitor
- (1) Class 2 high voltage ceramic dielectric capacitors
- (2) Diameter Code
- (3) Temp. Characteristics: B, E, F
- (4) Capacitance Code.
- (5) Tolerance Code: K, M, Z
- (6) Rated Voltage Code
- (7) Lead Style. Ref To Configuration
- (8) Lead Spacing Code.  
Refer To (CCD-Ord) document
- (10) Package & Lead Length.

Please Refer To Complete Ordering Code Document (CCD-Ord) For More Ordering

Option

## Body Diameter (mm)

CODE	05	06	07	08	09	10	11	12	13	14	15
D max.	5.5	6.5	7.5	8.5	9.5	10.5	11.5	12.5	13.5	14.5	15.5
CODE	16	17	18	19	20	21	22				
D max.	16.5	17.5	18.5	19.5	20.5	21.5	22.5				
CODE	EE	FF	GG	HH	II	JJ	KK	LL	MM	NN	OO
D max.	5.0	6.0	7.0	8.0	9.0	10.0	11.0	12.0	13.0	14.0	15.0
CODE	PP	QQ	RR	SS	TT	UU	VV				
D max.	16.0	17.0	18.0	19.0	20.0	21.0	22.0				

Capacitor

# CCD-W Series

Ceramic Disc Capacitors (Class 2 high voltage low D.F. ceramic dielectric capacitors)

**TRIGON**  
COMPONENTS

## Configuration:

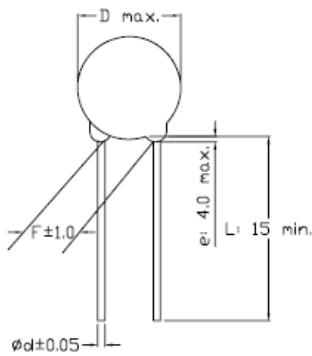

Lead Style "L"

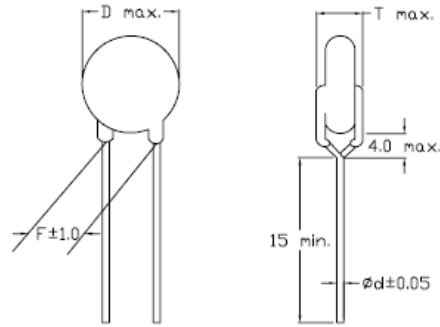

Lead Style "K"

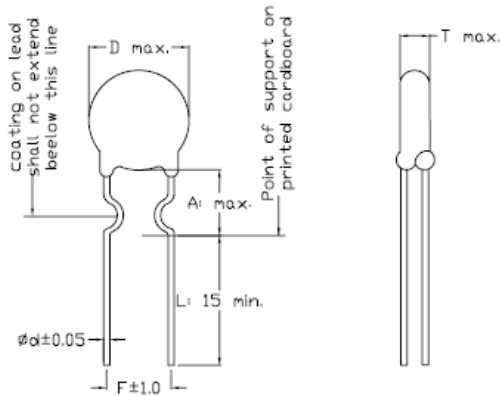

Lead Style "Y"

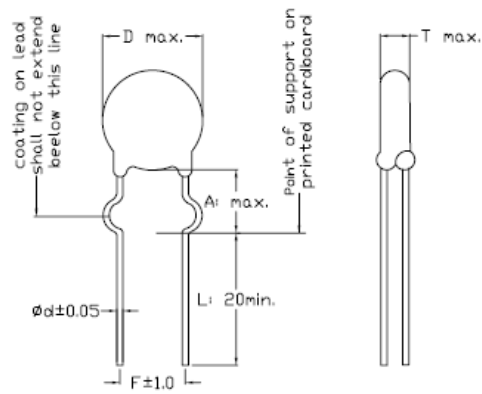

Lead Style "Z"

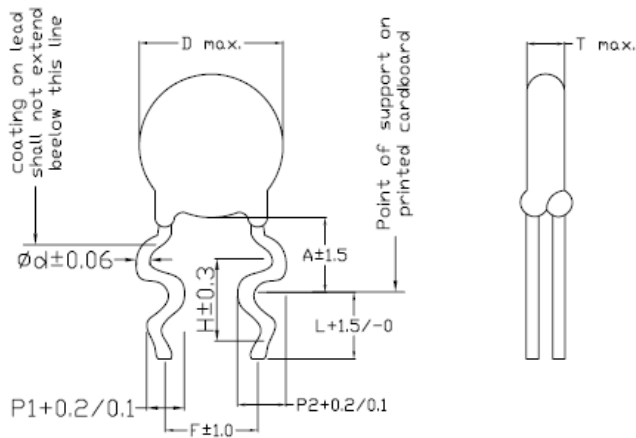





Lead Style "D"

Capacitor

# CCD-W Series

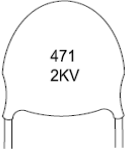
Ceramic Disc Capacitors (Class 2 high voltage low B.D.F. ceramic dielectric capacitors)

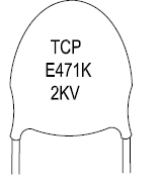
## MARKING:

BODY DIAMETER(mm)	MARKING ITEM	EXAMPLE
B(Y5P)	a: Nominal Capacitors b: Rated Voltage	
E(Y5U)	a: Nominal Capacitors b: Capacitance Tolerance : K · M · Z c: Rated Voltage: actual value	
F(Y5V)	a: Nominal Capacitors b: Capacitance Tolerance : K · M · Z c: Rated Voltage d: Temperature Characteristic : E (Y5U) , F (Y5V) e: Manufacturer's Trade Mark	  

Capacitor

1. Mark Color: Black or Nearly Color
2. Nominal Capacitance: 3 Digital Code
3. Capacitance Tolerance: Marked With Code
4. Rated Voltage: Actual Value
5. Manufacturers Identification :Marked With TCP

## CAPACITANCE VS TEMPERATURE CURVE:

Char: B(Y5P)

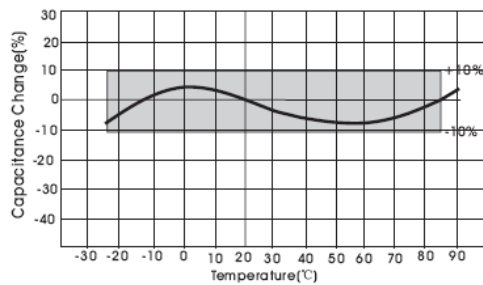

Char:E (Y5U)

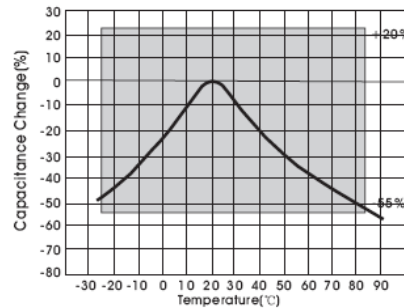

Char:F (Y5V)

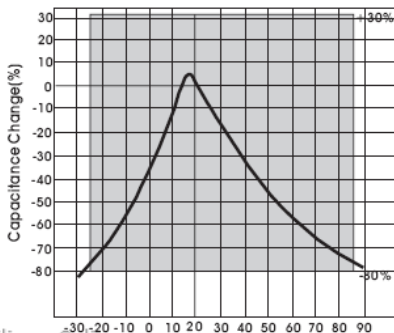

# CCD-W Series

Ceramic Disc Capacitors (Class 2 high voltage low B.D.F. ceramic dielectric capacitors)

**TRIGON**  
COMPONENTS

## CAPACITANCE, VOLTAGE, DIAMETER & THICKNESS DISTRIBUTION DIAGRAM

Voltage	1KVDC			2KVDC			3KVDC		
	B (Y5P)	E (Y5U)	F (Y5V)	B (Y5P)	E (Y5U)	F (Y5V)	B (Y5P)	E (Y5U)	F (Y5V)
Temp. Char.	±10%	±20%	+80%~-20%	±10%	±20%	+80%~-20%	±10%	±20%	+80%~-20%
Thickness	4.0 max	4.0 max	4.0 max	5.0 max	5.0 max	5.0 max	6.0 max	6.0 max	6.0 max
Cap. pF	DIA (max) Pin Pitch	DIA (max) Pin Pitch	DIA (max) Pin Pitch	DIA (max) Pin Pitch	DIA (max) Pin Pitch	DIA (max) Pin Pitch	DIA (max) Pin Pitch	DIA (max) Pin Pitch	DIA (max) Pin Pitch
100	7.0 / 5.0	NA	NA	7.0 / 5.0	NA	NA	8.0 / 7.5	NA	NA
120	7.0 / 5.0	NA	NA	7.0 / 5.0	NA	NA	8.0 / 7.5	NA	NA
150	7.0 / 5.0	NA	NA	7.0 / 5.0	NA	NA	8.0 / 7.5	NA	NA
180	7.0 / 5.0	NA	NA	7.0 / 5.0	NA	NA	8.0 / 7.5	NA	NA
220	7.0 / 5.0	NA	NA	7.0 / 5.0	NA	NA	8.0 / 7.5	NA	NA
270	7.0 / 5.0	NA	NA	7.0 / 5.0	NA	NA	8.0 / 7.5	NA	NA
330	7.0 / 5.0	NA	NA	7.0 / 5.0	NA	NA	8.0 / 7.5	NA	NA
390	7.0 / 5.0	NA	NA	7.0 / 5.0	NA	NA	8.0 / 7.5	NA	NA
470	7.0 / 5.0	NA	NA	7.0 / 5.0	NA	NA	8.0 / 7.5	NA	NA
560	7.0 / 5.0	NA	NA	8.0 / 5.0	NA	NA	8.0 / 7.5	NA	NA
680	7.0 / 5.0	NA	NA	8.0 / 5.0	NA	NA	9.0 / 7.5	NA	NA
820	7.0 / 5.0	NA	NA	8.0 / 5.0	NA	NA	10.0 / 7.5	NA	NA
1000	7.0 / 5.0	7.0 / 5.0	NA	9.0 / 5.0	7.0 / 7.5	7.0 / 5.0	11.0 / 7.5	8.0 / 7.5	8.0 / 7.5
1200	7.0 / 5.0	7.0 / 5.0	NA	9.0 / 5.0	7.0 / 5.0	7.0 / 5.0	11.0 / 7.5	9.0 / 7.5	8.0 / 7.5
1500	8.0 / 5.0	7.0 / 5.0	NA	10.0 / 5.0	8.0 / 5.0	7.0 / 5.0	12.0 / 7.5	9.0 / 7.5	8.0 / 7.5
1800	9.0 / 5.0	7.0 / 5.0	NA	11.0 / 5.0	8.0 / 5.0	7.0 / 5.0	13.0 / 7.5	9.0 / 7.5	8.0 / 7.5
2200	9.0 / 5.0	7.0 / 5.0	NA	11.0 / 5.0	8.0 / 5.0	7.0 / 5.0	14.0 / 7.5	10.0 / 7.5	8.0 / 7.5
2700	10.0 / 5.0	8.0 / 5.0	NA	13.0 / 7.5	10.0 / 7.5	8.0 / 5.0	15.0 / 7.5	10.0 / 7.5	9.0 / 7.5
3300	11.0 / 5.0	8.0 / 5.0	7.0 / 5.0	14.5 / 7.5	10.0 / 7.5	8.0 / 5.0	17.0 / 10.0	11.0 / 7.5	9.0 / 7.5
3900	12.0 / 7.5	9.0 / 5.0	8.0 / 5.0	15.0 / 7.5	11.0 / 7.5	9.0 / 5.0	18.0 / 10.0	12.0 / 7.5	11.0 / 7.5
4700	13.0 / 7.5	10.0 / 5.0	8.0 / 5.0	17.0 / 7.5	11.0 / 7.5	10.0 / 5.0	19.0 / 10.0	13.0 / 7.5	11.0 / 7.5
5600	14.0 / 7.5	10.0 / 5.0	8.0 / 5.0	NA	13.0 / 7.5	10.0 / 7.5	NA	15.0 / 7.5	12.0 / 7.5
6800	15.0 / 7.5	11.0 / 5.0	9.0 / 5.0	NA	13.0 / 7.5	11.0 / 7.5	NA	16.0 / 10.0	12.0 / 10.0
8200	17.0 / 7.5	12.0 / 7.5	10.0 / 5.0	NA	13.0 / 7.5	13.0 / 7.5	NA	18.0 / 10.0	14.0 / 10.0
10000	18.0 / 7.5	12.0 / 7.5	10.0 / 5.0	NA	16.0 / 7.5	13.0 / 7.5	NA	19.0 / 10.0	15.0 / 10.0
15000	NA	15.0 / 7.5	NA	NA	NA	15.0 / 7.5	NA	NA	18.0 / 10.0
22000	NA	18.0 / 7.5	14.0 / 7.5	NA	NA	18.0 / 10.0	NA	NA	21.0 / 10.0
33000	NA	NA	17.0 / 7.5	NA	NA	NA	NA	NA	NA

Capacitor

Operating Temperature Range: -25 to +125°C.  
D.F Char. D,E: 2.5% max. Char. F: 5.0% max.

# CCD-W Series

Ceramic Disc Capacitors (Class 2 high voltage low B.D.F. ceramic dielectric capacitors)

**TRIGON**  
COMPONENTS

## CAPACITANCE, VOLTAGE, DIAMETER & THICKNESS DISTRIBUTION DIAGRAM

Voltage	4KVDC			5KVDC			6KVDC		
	B (Y5P)	E (Y5U)	F (Y5V)	B (Y5P)	E (Y5U)	F (Y5V)	B (Y5P)	E (Y5U)	F (Y5V)
Temp. Char.	±10%	±20%	+80%~-20%	±10%	±20%	+80%~-20%	±10%	+80%~-20%	+80%~-20%
Thickness	6.0 max	6.0 max	6.0 max	7.0 max	7.0 max	7.0 max	8.0 max	8.0 max	8.0 max
Cap. pF	DIA (max) Pin Pitch	DIA (max) Pin Pitch	DIA (max) Pin Pitch	DIA (max) Pin Pitch	DIA (max) Pin Pitch	DIA (max) Pin Pitch	DIA (max) Pin Pitch	DIA (max) Pin Pitch	DIA (max) Pin Pitch
100	8.0 / 10.0	NA	NA	8.0 / 10.0	NA	NA	8.0 / 10.0	NA	NA
150	8.0 / 10.0	NA	NA	8.0 / 10.0	NA	NA	8.0 / 10.0	NA	NA
220	8.0 / 10.0	NA	NA	8.0 / 10.0	NA	NA	9.0 / 10.0	NA	NA
330	8.0 / 10.0	NA	NA	8.0 / 10.0	NA	NA	9.0 / 10.0	NA	NA
470	9.0 / 10.0	NA	NA	9.0 / 10.0	NA	NA	9.0 / 10.0	NA	NA
680	10.0 / 10.0	NA	NA	10.0 / 10.0	NA	NA	11.0 / 10.0	NA	NA
1000	12.0 / 10.0	9.0 / 10.0	8.0 / 10.0	13.0 / 10.0	9.0 / 10.0	8.0 / 10.0	13.0 / 10.0	9.0 / 10.0	8.0 / 10.0
1500	NA	11.0 / 10.0	8.5 / 10.0	NA	10.0 / 10.0	8.0 / 10.0	NA	10.0 / 10.0	9.0 / 10.0
2200	NA	12.0 / 10.0	9.0 / 10.0	NA	11.0 / 10.0	9.0 / 10.0	NA	12.0 / 10.0	10.0 / 10.0
3300	NA	14.0 / 10.0	11.0 / 10.0	NA	13.0 / 10.0	11.0 / 10.0	NA	13.0 / 10.0	11.0 / 10.0
4700	NA	17.0 / 10.0	12.0 / 10.0	NA	16.0 / 10.0	13.0 / 10.0	NA	17.0 / 10.0	13.0 / 10.0
10000	NA	NA	17.0 / 10.0	NA	NA	18.0 / 10.0	NA	NA	20.0 / 10.0

Voltage	8KVDC		
	B (Y5V)	E (Y5U)	F (Y5V)
Temp. Char.	±10%	+80%~-20%	+80%~-20%
Thickness	8.0 max	8.0 max	8.0 max
Cap. pF	DIA (max) Pin Pitch	DIA (max) Pin Pitch	DIA (max) Pin Pitch
100	9.0 / 10.0	NA	NA
150	9.0 / 10.0	NA	NA
220	9.0 / 10.0	NA	NA
330	10.0 / 10.0	NA	NA
470	11.0 / 10.0	NA	NA
680	13.0 / 10.0	NA	NA
1000	15.0 / 10.0	11.0 / 10.0	9.0 / 10.0
1500	NA	13.0 / 10.0	10.0 / 10.0
2200	NA	15.0 / 10.0	12.0 / 10.0
3300	NA	18.0 / 10.0	14.0 / 10.0
4700	NA	22.0 / 10.0	16.0 / 10.0
10000	NA	NA	23.0 / 10.0

Operating Temperature Range: -25 to +125°C.  
D,F Char. D,E: 2.5% max. Char. F: 5.0% max.

Capacitor

# CCD-W Series

Ceramic Disc Capacitors (Class 2 high voltage low B.D.F. ceramic dielectric capacitors)



## CAPACITANCE, VOLTAGE, DIAMETER & THICKNESS DISTRIBUTION DIAGRAM

Voltage	1KVDC	2KVDC	3KVDC
Temp. Char.	X/(X7R) ±10%	X/(X7R) ±10%	X/(X7R) ±10%
Thickness	4.0 max DIA (max) Pin Pitch	4.0 max DIA (max) Pin Pitch	6.0 max DIA (max) Pin Pitch
Cap. pF			
100	7.0 / 5.0	7.0 / 5.0	8.0 / 7.5
120	7.0 / 5.0	7.0 / 5.0	8.0 / 7.5
150	7.0 / 5.0	7.0 / 5.0	8.0 / 7.5
180	7.0 / 5.0	7.0 / 5.0	8.0 / 7.5
220	7.0 / 5.0	7.0 / 5.0	8.0 / 7.5
270	7.0 / 5.0	7.0 / 5.0	8.0 / 7.5
330	7.0 / 5.0	7.0 / 5.0	8.0 / 7.5
390	7.0 / 5.0	7.0 / 5.0	8.0 / 7.5
470	7.0 / 5.0	7.0 / 5.0	8.0 / 7.5
560	7.0 / 5.0	8.0 / 5.0	9.0 / 7.5
680	7.0 / 5.0	8.0 / 5.0	9.0 / 7.5
820	7.0 / 5.0	8.0 / 5.0	10.0 / 7.5
1000	7.0 / 5.0	9.0 / 5.0	11.0 / 7.5
1200	7.0 / 5.0	9.0 / 5.0	11.0 / 7.5
1500	8.0 / 5.0	10.0 / 5.0	12.0 / 7.5
1800	9.0 / 5.0	11.0 / 5.0	13.0 / 7.5
2200	9.0 / 5.0	11.0 / 5.0	14.0 / 7.5
2700	10.0 / 5.0	13.0 / 7.5	15.0 / 7.5
3300	11.0 / 5.0	13.0 / 7.5	17.0 / 10.0
3900	12.0 / 7.5	15.0 / 7.5	18.0 / 10.0
4700	13.0 / 7.5	17.0 / 7.5	19.0 / 10.0
5600	14.0 / 7.5	NA	NA
6800	15.0 / 7.5	NA	NA
8200	17.0 / 7.5	NA	NA
10000	18.0 / 7.5	NA	NA

Trigon Components reserves the rights for revising the content of this catalog without further notification.

# CCD-W Series

Ceramic Disc Capacitors (Class 2 high voltage low B.D.F. ceramic dielectric capacitors)

**TRIGON**  
COMPONENTS

## SPECIFICATION AND TEST METHOD

### Test condition

Test and measurement shall be made at the standard condition, (Temperature 15 to 35°C, relative humidity 45 to 75% and atmospheric pressure 860-1060 hpa), unless otherwise specified herein

If doubt occurred on the value of measurement, and remeasurement was requested by customer capacitors shall be measured at the reference condition (Temperature 20±2° relative humidity 60 to 70% and atmospheric pressure 860-1060 hpa), unless otherwise specified herein

### Performance

No	Item	Specification	Testing Method												
1	Operating Temperature Range	-25 to +125°C	-----												
2	Appearance and Dimensions	No marked defect on appearance from and dimensions are within specified range.	The capacitor shall be inspected by naked eyes for Visible evidence of defect. Dimensions shall be measured with slide calipers.												
3	Marking	To be easily legible.	The capacitor shall be inspected by naked eyes.												
4	Dielectric Strength	Between Lead Wires	No failure. The capacitor shall not be damage when DC voltage of 150% the rated voltage is applied between the lead wires for 1 to 5 s. (Charge/Discharge current ≤50mA.)												
		Body Insulation	No failure. The capacitor is placed in the container with metal balls of diameter 1mm so that each lead wire, short circuited, is kept about 2mm off the balls as shown in the figure, and DC Voltage of 1.3kV is applied for 1 to 5 s between capacitor lead wires and small metals. (Charge/Discharge current ≤50mA.)												
5	Insulation Resistance (I.R.)	Between Lead Wires C*1 ≤ 0.02μF: 10000MΩ Min C*1 > 0.02μF: 7500.MΩ Min	The insulation resistance shall be measured with DC500±50V within 60±5 s of charging												
6	Capacitance	Within specified tolerance.	The capacitance shall be measured at 20 ±2□ with 1±0.2KHz and AC1±0.1V(r.m.s)												
7	Dissipation Factor (D.F.)	Char. D,E: 2.5% max. Char. F: 5.0% max.	The dissipation factor shall be measured at 20±2□ with 1±0.2KHz and AC 1±0.1V(r.m.s)												
8	Temperature Characteristic	Char. B: within ±10% Char. E: within +20/-50% Char. F: within +30/-80%	The capacitance measurement shall be made at each step specified in Table												
		Pre-treatment: Capacitor shall be stored at 85±2°C for 1h then placed at*room condition for 24±2h before measurements.													
		<table border="1"> <thead> <tr> <th>Step</th> <th>1</th> <th>2</th> <th>3</th> <th>4</th> <th>5</th> </tr> </thead> <tbody> <tr> <td>Temp. (°C)</td> <td>20±2</td> <td>-25±3</td> <td>20±2</td> <td>85±2</td> <td>20±2</td> </tr> </tbody> </table>	Step	1	2	3	4	5	Temp. (°C)	20±2	-25±3	20±2	85±2	20±2	
Step	1	2	3	4	5										
Temp. (°C)	20±2	-25±3	20±2	85±2	20±2										
9	Strength of Lead	Pull	As a figure, fix the body of capacitor, apply a tensile Weight gradually to each lead wire in the radial direction of capacitor up to 10N(5N for lead diameter φ 0.5mm), and keep it for 10±1S												
		Bending	Each lead wire shall be subjected to 5N(2.5N for lead diameter φ 0.5mm) weight and then a 90 deg bend, at the point of egress, in one direction, return to original position, and then a 90 deg bend in the opposite direction at the rate of one bend in 2 to 3S.												

Capacitor

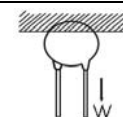
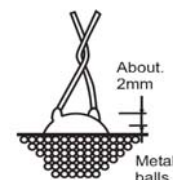

# CCD-W Series

Ceramic Disc Capacitors (Class 2 high voltage Low B.D.F. ceramic dielectric capacitors)

**TRIGON**  
COMPONENTS

Capacitor

10	Vibration Resistance	Appearance	No marked defect.	The capacitor shall firmly be soldered to the supporting lead wire and vibration which is 10 to 55Hz in the vibration frequency range, 1.5mm in total amplitude, and about 1min. In the rate of vibration change from 10Hz to 55Hz and back to 10Hz is applied for a total of 6 h; 2 h each in 3 mutually perpendicular directions.																															
		Capacitance	Within specified tolerance.																																
		D.F.	Char. B, E: 2.5% max Char. F: 5.0% max																																
11	Solderability of Leads	Lead wire shall be soldered with uniformly coated on the axial direction over 3/4 of the circumferential direction.		The lead wire of a capacitor shall be dipped into a ethanol solution of 25 wt% rosin and then into molten solder of 235±5°C for 2±0.5s In both cases the depth of dipping is up to about 1.5 to 2mm from the root of lead wires.																															
12	Soldering Effect	Appearance	No marked defect	The lead wire shall be immersed into the melted solder of 350±10°C or 260±5°C up to about 1.5 to 2.0mm from the main body for 3.5±0.5s (10±1s for 260±5°C) Pre-treatment : Capacitor shall be stored at 85±2°C for 1h then placed at room condition for 24±2h before initial measurements. Post-treatment : Capacitor shall be stored for 4to24h at room condition.																															
		Capacitance Change	Char. B : within ±5% Char. E : within ±15% Char. F : within ±20%																																
		Dielectric Strength (Between Lead Wires)	Per item 4.																																
13	Humidity (Under Steady State)	Appearance	No marked defect.	Set the capacitor for 500+24/-0h at 40±2°C in 90to 95% relative Humidity Pre-treatment : Capacitor shall be stored at 8±2°C for 1h then placed At room condition for 24±2h before initial measurements. Post-treatment : Capacitor shall be stored for 1to 2h at room condition.																															
		Capacitance change	Char. B : within ±10% Char. E : within ±20% Char. F : within ±30%																																
		D.F.	Char. B, E: 5% max Char. F: 7.5% max																																
		I.R.	1000MΩ min																																
14	Humidity Loading	Appearance	No marked defect.	Apply the rated voltage for 500 +24/-0 at 40±2°C in 90 to 95% relative Humidity(Charge/Discharge current ≤50mA) Pre-treatment : Capacitor shall be stored at 85±2°C for 1h then placed At room condition for 24±2h before initial measurements. Post-treatment : Capacitor shall be stored at 85±2°C for 1h,then placed at*room condition for 24±2h.																															
		Capacitance change	Char. B : within ±10% Char. E : within ±20% Char. F : within ±30%																																
		D.F.	Char. B, E: 5% max Char. F: 7.5% max																																
		I.R.	500MΩ min																																
15	Life	Appearance	No marked defect.	Apply a DC voltage 150% of the rated voltage for1000 +48/-0h at 85± 2 °C and relative humidity of 50% max.. (Charge/Discharge current 500mA) Pre-treatment : Capacitor shall be stored at 85±2°C for 1h then placed At room condition for 24±2h before initial measurements. Post-treatment : Capacitor shall be stored at 85±2°C for 1h then placed At room condition for 24±2h.																															
		Capacitance change	Char. E : within ±10% Char. E : within ±20% Char. F : within ±30%																																
		D.F.	Char. B, E: 4.5% max Char. F: 7.5% max																																
		I.R.	2000MΩ min																																
16	Temperature D.F. and Immersion Cycle	Appearance	No marked defect.	The capacitor shall be subjected to 5 temperature cycles. The consecutively to 2 immersion cycles. <Temperature cycle> <table border="1" style="display: inline-table; margin-right: 20px;"> <thead> <tr> <th>Step</th> <th>Temperature(°C)</th> <th>Time</th> </tr> </thead> <tbody> <tr> <td>1</td> <td>-25°C±3</td> <td>30 Min</td> </tr> <tr> <td>2</td> <td>Room Temp</td> <td>3 Min</td> </tr> <tr> <td>3</td> <td>+85°C±3</td> <td>30 Min</td> </tr> <tr> <td>4</td> <td>Room Temp</td> <td>3 Min</td> </tr> </tbody> </table> <table border="1" style="display: inline-table;"> <thead> <tr> <th colspan="4">&lt;Temperature cycle&gt;</th> </tr> <tr> <th>Step</th> <th>Temperature(°C)</th> <th>Time</th> <th>Immersion Water</th> </tr> </thead> <tbody> <tr> <td>1</td> <td>+65°C+5/-0</td> <td>15 Min</td> <td>Clean Water</td> </tr> <tr> <td>2</td> <td>0±3</td> <td>15 Min</td> <td>Salt Water</td> </tr> </tbody> </table> Cycle time: 5 cycle Pre-treatment : Capacitor shall be stored at 105±2°C for 1h then placed At room condition for 24±2h before initial measurements. Post-treatment : Capacitor shall be stored for 4 to24h at room condition.	Step	Temperature(°C)	Time	1	-25°C±3	30 Min	2	Room Temp	3 Min	3	+85°C±3	30 Min	4	Room Temp	3 Min	<Temperature cycle>				Step	Temperature(°C)	Time	Immersion Water	1	+65°C+5/-0	15 Min	Clean Water	2	0±3	15 Min	Salt Water
		Step	Temperature(°C)		Time																														
		1	-25°C±3		30 Min																														
		2	Room Temp		3 Min																														
		3	+85°C±3		30 Min																														
4	Room Temp	3 Min																																	
<Temperature cycle>																																			
Step	Temperature(°C)	Time	Immersion Water																																
1	+65°C+5/-0	15 Min	Clean Water																																
2	0±3	15 Min	Salt Water																																
Capacitance change	Char. B : within ±20% Char. E : within ±20% Char. F : within ±30%																																		
D.F.	Char. B, E: 4.0% max Char. F: 7.5% max																																		
I.R.	2000MΩ min																																		
Dielectric Strength (Between Lead Wires)	Per item 4.																																		

# SOLDERING PROFILE

Ceramic Disc Capacitors (Class 2 high voltage Low D.F. ceramic dielectric capacitors)

**TRIGON**  
COMPONENTS

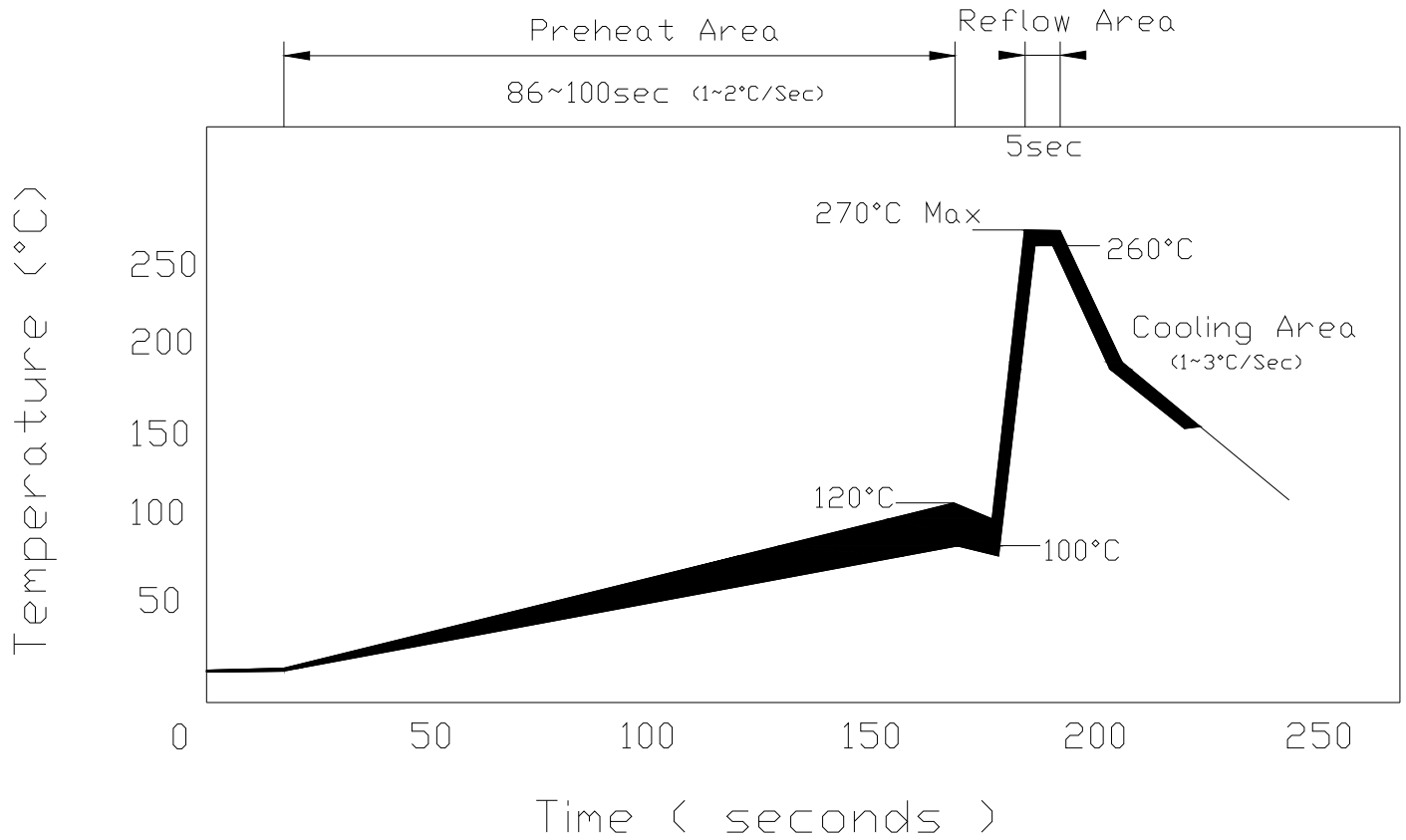

(Pb-Free Assembly)

# CCD-W Series

Ceramic Disc Capacitors (Class 2 high voltage low B.D.F. ceramic dielectric capacitors)

**TRIGON**  
COMPONENTS

## TAPING SPECIFICATION

- 12.7mm pitch/lead spacing 5.0/7.5mm taping
- 30mm pitch/lead spacing 7.5/10.0mm taping

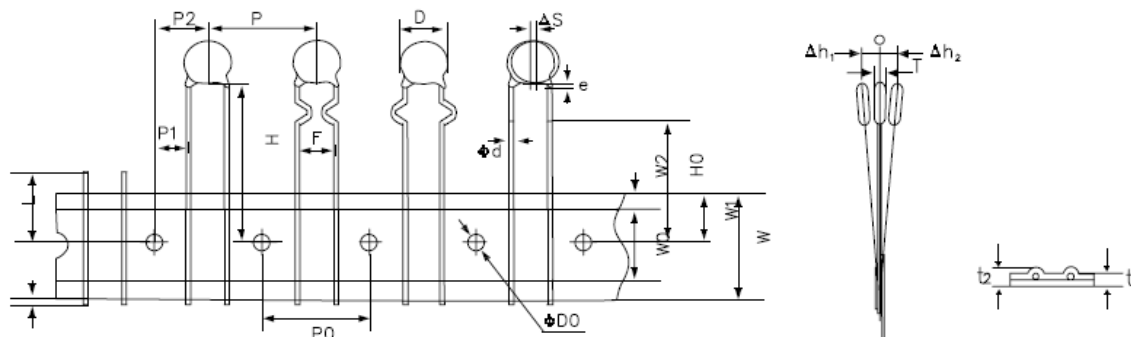

Item	Code	Dimension
Pitch of component	P	12.7/25.4
Pitch of sprocket hole	P0	12.7±0.3
Lead spacing	F	5.0±1.0/7.5±1.0/10.0±1.0
Length from hole center to component center	P2	6.35±1.3/12.7±1.3
Length from hole center to lead	P1	3.85±0.7/2.6±0.7/8.95±1.0/7.7±1.0
Body diameter	D	See the individual product specification
Deviation along tape, left or right	ΔS	0±2.0
Carrier tape width	W	18.0±0.5
Position of sprocket hole	W1	9.0±0.5
Lead distance between reference and bottom planes	H	20.0±1.5
Diameter of sprocket hole	φ D0	4.0±0.2
Total thickness, tape and lead wire	φ d	0.55±0.3
Lead diameter	t1	0.55±0.3
Total tape thickness	t2	2.0 max.
Body thickness	T	See the individual product specification
Portion to cut in case of defect	L	11.0 max.
Hold down tape width	W0	10±2
Hold down tape position	W2	1.5±1.5
Coating extension on lead	e	Up to the end of crimp
Deviation across tape	Δh1	2.0 max.
	Δh2	

Capacitor

# CCD-W Series

Ceramic Disc Capacitors (Class 2 high voltage low B.D.F. ceramic dielectric capacitors)

**TRIGON**  
COMPONENTS

- 15.0mm pitch/lead spacing 5.0/7.5mm taping
- 30mm pitch/lead spacing 7.5/10.0mm taping

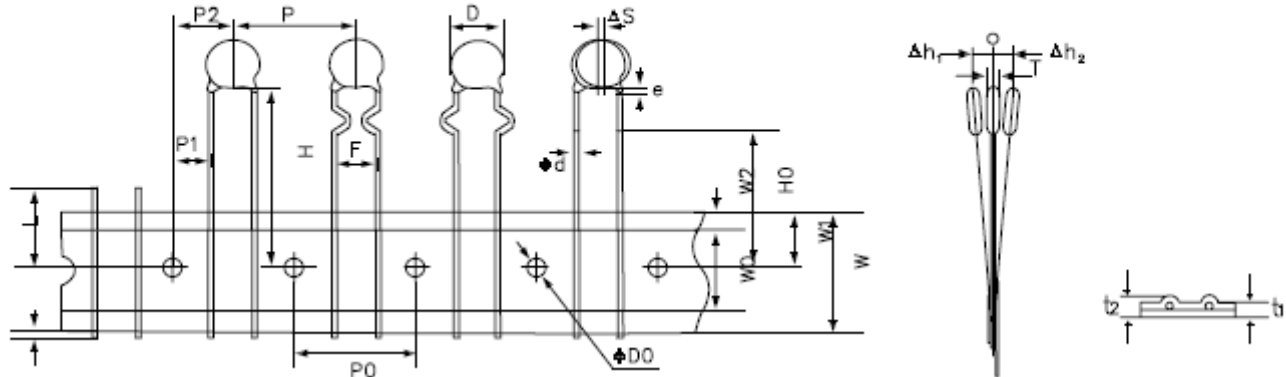

Capacitor

Item	Code	Dimension
Pitch of component	P	15.0/30.0
Pitch of sprocket hole	P0	15.0±0.3
Lead spacing	F	5.0±1.0/7.5±1.0/10.0±1.0
Length from hole center to component center	P2	7.35±1.3/15.0±1.3
Length from hole center to lead	P1	5.0±0.7/3.75±0.7/11.25±0.7/10.0±1.0
Body diameter	D	See the individual product specification
Deviation along tape, left or right	△S	0±2.0
Carrier tape width	W	18.0±0.5
Position of sprocket hole	W1	9.0±0.5
Lead distance between reference and bottom planes	H	20.0±1.5
Diameter of sprocket hole	φ D0	4.0±0.2
Total thickness, tape and lead wire	φ d	0.55±0.05
Lead diameter	t1	0.6±0.3
Total tape thickness	t2	2.0 max.
Body thickness	T	See the individual product specification
Portion to cut in case of defect	L	11.0 max.
Hold down tape width	W0	10.0±2
Hold down tape position	W2	1.5±1.5
Coating extension on lead	e	Up to the end of crimp
Deviation across tape	△h1	2.0 max.
	△h2	

# CCD-W Series

Ceramic Disc Capacitors (Class 2 high voltage Low D.F. ceramic dielectric capacitors)

**TRIGON**  
COMPONENTS

## PACKAGING STYLES

### Taping: Reel Packaging

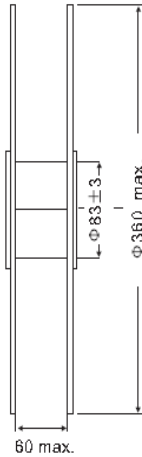
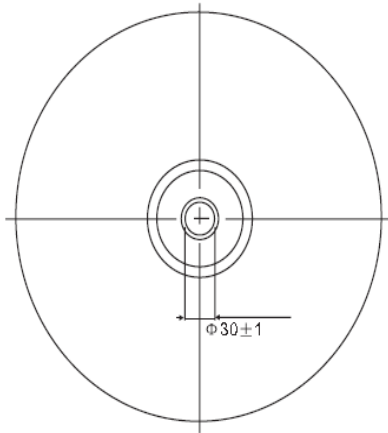

Unit: mm

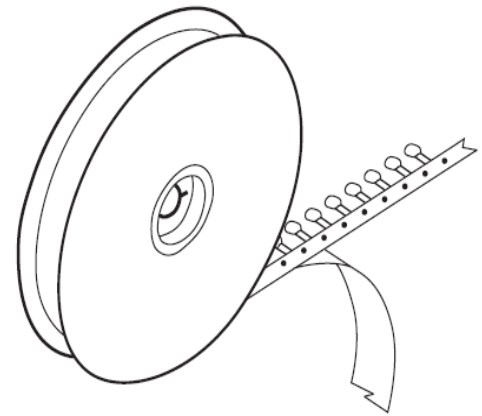

Capacitor

### Taping: Ammo Box

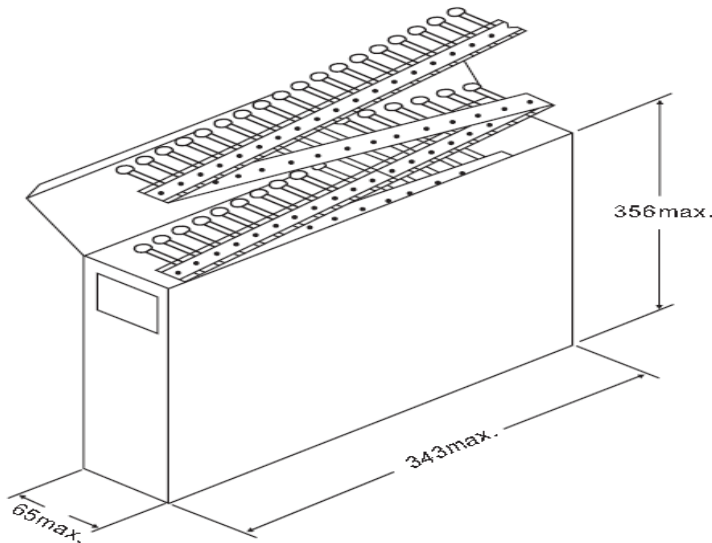

### Bulk: Polyethylene Bag

# CCD-W Series

Ceramic Disc Capacitors (Class 2 high voltage low B.D.F. ceramic dielectric capacitors)

**TRIGON**  
COMPONENTS

## PACKAGING QUANTITY

Bulk (at standards specification)

Body Diameter 4.5 to 9.0 mm : 1000 pcs

Body Diameter 10 mm over : 500 pcs

Taping

Pitch : 12.7/25.4 mm

Body Diameter 4.5 to 8.0 mm : 1500 pcs./Box



Body Diameter 9.0 mm over : 1000 pcs./Box

## LABEL AND TRANSPORT

Capacitors shall be packaged prior to shipment so as to prevent damage during transportation and storage.

Shipping carton contains the following information on the label

Capacitor

TRIGON	
C/PN: *****	
	RoHS Compliant
P/No: CCD-WXXXXXXXXXX	
	
DESCRIPTION:	LOT NO: XXXXXXXX
Ceramic Disc Capacitors *****	
Q/ty: 7500pcs	D/C: *****
	D/□: P0*****
	Made in China

## Looking for pricing, stock, or lifecycle information?

Click below to explore more details on WIN SOURCE:

 [View CCD-WOOE222Z632L02 on WIN SOURCE](#)

 [Trigon Components](#) Information

## Optimize Your Supply Chain with WIN SOURCE Solutions

-  Global Sourcing Solution
-  Obsolete Management
-  Cost Control Management
-  Shortage Management
-  Alternative Solution
-  Excess Inventory Management